



US007713748B2

(12) **United States Patent**
Wei

(10) **Patent No.:** **US 7,713,748 B2**
(45) **Date of Patent:** **May 11, 2010**

(54) **METHOD OF REDUCING THE SENSITIVITY OF ASSAY DEVICES**

(75) Inventor: **Ning Wei**, Roswell, GA (US)

(73) Assignee: **Kimberly-Clark Worldwide, Inc.**,
Neenah, WI (US)

(*) Notice: Subject to any disclaimer, the term of this patent is extended or adjusted under 35 U.S.C. 154(b) by 846 days.

(21) Appl. No.: **10/718,996**

(22) Filed: **Nov. 21, 2003**

(65) **Prior Publication Data**

US 2010/0081146 A1 Apr. 1, 2010

(51) **Int. Cl.**

G01N 21/00 (2006.01)
G01N 15/06 (2006.01)
G01N 21/76 (2006.01)
G01N 33/53 (2006.01)
G01N 33/543 (2006.01)
G01N 33/544 (2006.01)
G01N 21/77 (2006.01)
G01N 33/566 (2006.01)
G01N 31/22 (2006.01)
C12M 1/34 (2006.01)
C12M 3/00 (2006.01)
C12Q 1/00 (2006.01)

(52) **U.S. Cl.** **436/518**; 435/4; 435/7.1; 435/287.1; 435/287.2; 435/287.7; 435/287.8; 435/288.7; 422/55; 422/56; 422/61; 422/68.1; 422/82.05; 436/164; 436/169; 436/501; 436/528; 436/172; 436/807

(58) **Field of Classification Search** 422/55, 422/56, 61, 68.1, 82.05; 435/4, 7.1, 287.1, 435/287.2, 287.7, 287.8, 288.7; 436/501, 436/518, 528, 164, 169, 172, 807

See application file for complete search history.

(56) **References Cited**

U.S. PATENT DOCUMENTS

1,366,241 A 1/1921 Burch
3,700,623 A 10/1972 Keim
3,772,076 A 11/1973 Keim
4,094,647 A 6/1978 Deutsch et al.
4,110,529 A 8/1978 Stoy
4,115,535 A 9/1978 Giaever

(Continued)

FOREIGN PATENT DOCUMENTS

EP 0073593 A1 3/1983

(Continued)

OTHER PUBLICATIONS

Abstract of Japanese Patent No. JP 8062214, Mar. 8, 1996.
Abstract of Article—*Factors influencing the formation of hollow ceramic microspheres by water extraction of colloidal droplets*, J. Mater. Res., vol. 10, No. 1, p. 84.

(Continued)

Primary Examiner—Gailene R Gabel
Assistant Examiner—Jacqueline Diramio
(74) *Attorney, Agent, or Firm*—Dority & Manning, P.A.

(57) **ABSTRACT**

A flow-through assay device for detecting the presence or quantity of an analyte residing in a test sample is provided. The device utilizes a scavenging zone that contains a capture reagent for the analyte of interest. The capture reagent may capture a quantity of the analyte that is less than or equal to a predefined base quantity of the analyte, such as a quantity considered “normal” for a particular test sample. Thus, the capture reagent is able to prevent some of the analyte from being detected. In this manner, the sensitivity of the assay device may be reduced in a simple, inexpensive, yet effective manner.

18 Claims, 4 Drawing Sheets

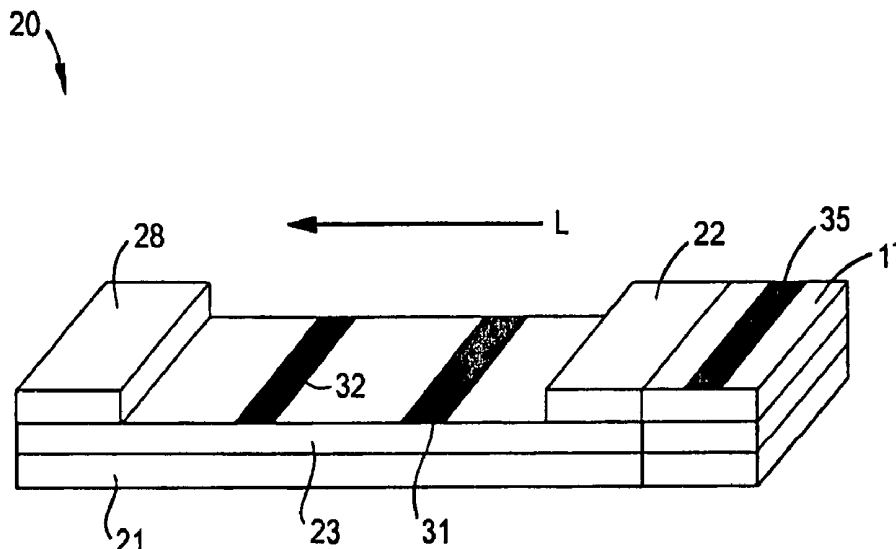

U.S. PATENT DOCUMENTS						
			5,026,653	A	6/1991	Lee et al.
			5,035,863	A	7/1991	Finlan et al.
			5,055,265	A	10/1991	Finlan
			5,063,081	A	11/1991	Cozzette et al.
			5,064,619	A	11/1991	Finlan
			5,073,340	A	12/1991	Covington et al.
			5,075,077	A	12/1991	Durley, III et al.
			5,075,078	A	12/1991	Osikowicz et al.
			5,076,094	A	12/1991	Frye et al.
			5,096,671	A	3/1992	Kane et al.
			5,114,676	A	5/1992	Leiner et al.
			5,120,643	A	6/1992	Ching et al.
			5,120,662	A	6/1992	Chan et al.
			5,124,254	A	6/1992	Hewlins et al.
			5,134,057	A	7/1992	Kuyppers et al.
			5,137,609	A	8/1992	Manian et al.
			5,143,854	A	9/1992	Pirrung et al.
			5,145,784	A	9/1992	Cox et al.
			5,149,622	A	9/1992	Brown et al.
			5,152,758	A	10/1992	Kaetsu et al.
			5,156,953	A	10/1992	Litman et al.
			5,166,079	A	11/1992	Blackwood et al.
			5,179,288	A	1/1993	Miffitt et al.
			5,182,135	A	1/1993	Giesecke et al.
			5,183,740	A	2/1993	Ligler et al.
			5,185,127	A	2/1993	Vonk
			5,196,350	A	3/1993	Backman et al.
			5,200,084	A	4/1993	Liberti et al.
			5,208,143	A	5/1993	Henderson et al.
			5,208,535	A	5/1993	Nakayama et al.
			5,221,454	A	6/1993	Manian et al.
			5,225,935	A	7/1993	Watanabe et al.
			5,234,813	A	8/1993	McGeehan et al.
			5,235,238	A	8/1993	Nomura et al.
			5,238,815	A	8/1993	Higo et al.
			5,242,828	A	9/1993	Bergström et al.
			5,252,459	A	10/1993	Tarcha et al.
			5,262,299	A	11/1993	Evangelista et al.
			5,268,306	A	12/1993	Berger et al.
			5,275,785	A	1/1994	May et al.
			5,304,468	A	4/1994	Phillips et al.
			5,314,923	A	5/1994	Cooke et al.
			5,316,727	A	5/1994	Suzuki et al.
			5,320,944	A	6/1994	Okada et al.
			5,321,492	A	6/1994	Detwiler et al.
			5,327,225	A	7/1994	Bender et al.
			5,330,898	A	7/1994	Bar-Or et al.
			5,342,759	A	8/1994	Litman et al.
			5,352,582	A	10/1994	Lichtenwalter et al.
			5,356,782	A	10/1994	Moorman et al.
			5,358,852	A	10/1994	Wu
			5,369,717	A	11/1994	Attridge
			5,374,531	A	12/1994	Jensen
			5,374,563	A	12/1994	Maule
			5,376,255	A	12/1994	Gumbrecht et al.
			5,387,503	A	2/1995	Selmer et al.
			5,395,754	A	3/1995	Lambotte et al.
			5,415,842	A	5/1995	Maule
			5,418,136	A	5/1995	Miller et al.
			5,424,219	A	6/1995	Jirikowski
			5,428,690	A	6/1995	Bacus et al.
			5,432,057	A	7/1995	Litman et al.
			5,436,161	A	7/1995	Bergström et al.
			5,445,971	A	8/1995	Rohr
			5,451,683	A	9/1995	Barrett et al.
			5,455,475	A	10/1995	Josse et al.
			5,464,741	A	11/1995	Hendrix
			5,466,574	A	11/1995	Liberti et al.
			5,467,778	A	11/1995	Catt et al.
			5,468,606	A	11/1995	Bogart et al.
			5,482,830	A	1/1996	Bogart et al.
			5,482,867	A	1/1996	Barrett et al.
			5,484,867	A	1/1996	Lichtenhan et al.
4,168,146	A	9/1979	Grubb et al.			
RE30,267	E	5/1980	Bruschi			
4,210,723	A	7/1980	Dorman et al.			
4,235,601	A	11/1980	Deutsch et al.			
4,275,149	A	6/1981	Litman et al.			
4,312,228	A	1/1982	Wohltjen			
4,363,874	A	12/1982	Greenquist			
4,366,241	A	12/1982	Tom et al.			
4,374,925	A	2/1983	Litman et al.			
4,385,126	A	5/1983	Chen et al.			
4,426,451	A	1/1984	Columbus			
4,427,836	A	1/1984	Kowalski et al.			
4,435,504	A	3/1984	Zuk et al.			
4,441,373	A	4/1984	White			
4,442,204	A	4/1984	Greenquist et al.			
4,444,592	A	4/1984	Ludwig			
4,477,635	A	10/1984	Mitra			
4,480,042	A	10/1984	Craig et al.			
4,533,499	A	8/1985	Clark et al.			
4,533,629	A	8/1985	Litman et al.			
4,534,356	A	8/1985	Papadakis			
4,537,657	A	8/1985	Keim			
4,537,861	A	8/1985	Elings et al.			
4,540,659	A	9/1985	Litman et al.			
4,552,458	A	11/1985	Lowne			
4,561,286	A	12/1985	Sekler et al.			
4,562,157	A	12/1985	Lowe et al.			
4,586,695	A	5/1986	Miller			
4,595,661	A	6/1986	Cragle et al.			
4,596,697	A	6/1986	Ballato			
4,614,723	A	9/1986	Schmidt et al.			
4,632,559	A	12/1986	Brunsting			
4,661,235	A	4/1987	Krull et al.			
4,698,262	A	10/1987	Schwartz et al.			
4,703,017	A	10/1987	Campbell et al.			
4,722,889	A	2/1988	Lee et al.			
4,727,019	A	2/1988	Valkirs et al.			
4,731,337	A	3/1988	Luotola et al.			
4,742,011	A	5/1988	Blake et al.			
4,743,542	A	5/1988	Graham, Jr. et al.			
4,743,560	A	5/1988	Campbell et al.			
4,776,944	A	10/1988	Janata et al.			
4,806,312	A	2/1989	Greenquist			
4,835,099	A	5/1989	Mize et al.			
4,837,168	A	6/1989	de Jaeger et al.			
4,842,783	A	6/1989	Blaylock			
4,843,000	A	6/1989	Litman et al.			
4,843,021	A	6/1989	Noguchi et al.			
4,844,613	A	7/1989	Batchelder et al.			
4,849,338	A	7/1989	Litman et al.			
4,855,240	A	8/1989	Rosenstein et al.			
4,857,453	A	8/1989	Ullman et al.			
4,867,908	A	9/1989	Recktenwald et al.			
4,877,586	A	10/1989	Devaney, Jr. et al.			
4,877,747	A	10/1989	Stewart			
4,889,816	A	12/1989	Davis et al.			
4,895,017	A	1/1990	Pyke et al.			
4,904,583	A	2/1990	Mapes et al.			
4,916,056	A	4/1990	Brown, III et al.			
4,917,503	A	4/1990	Bhattacharjee			
4,920,045	A	4/1990	McFarland et al.			
4,940,734	A	7/1990	Ley et al.			
4,954,435	A	9/1990	Krauth			
4,956,302	A	9/1990	Gordon et al.			
4,963,498	A	10/1990	Hillman et al.			
4,973,670	A	11/1990	McDonald et al.			
4,978,625	A	12/1990	Wagner et al.			
4,980,298	A	12/1990	Blake et al.			
4,992,385	A	2/1991	Godfrey			
5,003,178	A	3/1991	Livesay			
5,023,053	A	6/1991	Finlan			

5,489,678 A	2/1996	Fodor et al.	5,989,924 A	11/1999	Root et al.
5,489,988 A	2/1996	Ackley et al.	5,989,926 A	11/1999	Badley et al.
5,492,840 A	2/1996	Malmqvist et al.	5,993,805 A	11/1999	Sutton et al.
5,500,350 A	3/1996	Baker et al.	5,998,221 A	12/1999	Malick et al.
5,504,013 A	4/1996	Senior	6,004,530 A	12/1999	Sagner et al.
5,508,171 A	4/1996	Walling et al.	6,020,047 A	2/2000	Everhart
5,510,481 A	4/1996	Bednarski et al.	6,027,904 A	2/2000	Devine et al.
5,512,131 A	4/1996	Kumar et al.	6,027,944 A	2/2000	Robinson et al.
5,514,559 A	5/1996	Markert-Hahn et al.	6,030,792 A	2/2000	Otterness et al.
5,514,785 A	5/1996	Van Ness et al.	6,030,840 A	2/2000	Mullinax et al.
5,516,635 A	5/1996	Ekins et al.	6,033,574 A	3/2000	Siddiqi
5,518,689 A	5/1996	Dosmann et al.	6,048,623 A	4/2000	Everhart et al.
5,518,883 A	5/1996	Soini	6,057,165 A	5/2000	Mansour
5,521,102 A	5/1996	Boehringer et al.	6,060,256 A	5/2000	Everhart et al.
5,527,711 A	6/1996	Tom-Moy et al.	6,077,669 A	6/2000	Little et al.
5,534,132 A	7/1996	Vreeke et al.	6,080,391 A	6/2000	Tsuchiya et al.
5,554,539 A	9/1996	Chadney et al.	6,084,683 A	7/2000	Bruno et al.
5,554,541 A	9/1996	Malmqvist et al.	6,087,184 A	7/2000	Magginetti et al.
5,569,608 A	10/1996	Sommer	6,099,484 A	8/2000	Douglas et al.
5,571,684 A	11/1996	Lawrence et al.	6,103,537 A	8/2000	Ullman et al.
5,573,909 A	11/1996	Singer et al.	6,117,090 A	9/2000	Caillouette
5,573,919 A	11/1996	Kearns et al.	6,130,100 A	10/2000	Jobling et al.
5,585,279 A	12/1996	Davidson	6,133,048 A	10/2000	Penfold et al.
5,589,401 A	12/1996	Hansen et al.	6,136,549 A	10/2000	Feistel
5,591,581 A	1/1997	Massey et al.	6,136,611 A	10/2000	Saaski et al.
5,591,645 A	1/1997	Rosenstein	6,139,961 A	10/2000	Blankenship et al.
5,596,414 A	1/1997	Tyler	6,151,110 A	11/2000	Markart
5,599,668 A	2/1997	Stimpson et al.	6,156,271 A	12/2000	May
5,602,040 A	2/1997	May et al.	6,165,798 A	12/2000	Brooks
5,610,077 A	3/1997	Davis et al.	6,171,780 B1	1/2001	Pham et al.
5,618,732 A	4/1997	Pease et al.	6,171,870 B1	1/2001	Freitag
5,618,888 A	4/1997	Choi et al.	6,174,646 B1	1/2001	Hirai et al.
5,620,850 A	4/1997	Bamdad et al.	6,177,281 B1	1/2001	Manita
5,622,871 A	4/1997	May et al.	6,180,288 B1	1/2001	Everhart et al.
5,637,509 A	6/1997	Hemmilä et al.	6,183,972 B1	2/2001	Kuo et al.
5,647,994 A	7/1997	Tuunanen et al.	6,184,042 B1	2/2001	Neumann et al.
5,656,503 A	8/1997	May et al.	6,187,269 B1	2/2001	Lancesseru et al.
5,658,443 A	8/1997	Yamamoto et al.	6,194,220 B1	2/2001	Malick et al.
5,663,213 A	9/1997	Jones et al.	6,200,820 B1	3/2001	Hansen et al.
5,670,381 A	9/1997	Jou et al.	6,221,238 B1	4/2001	Grundig et al.
5,672,256 A	9/1997	Yee	6,221,579 B1	4/2001	Everhart et al.
5,700,636 A	12/1997	Sheiness et al.	6,234,974 B1	5/2001	Catt et al.
5,714,389 A	2/1998	Charlton et al.	6,235,241 B1	5/2001	Catt et al.
5,726,064 A	3/1998	Robinson et al.	6,235,471 B1	5/2001	Knapp et al.
5,731,147 A	3/1998	Bard et al.	6,235,491 B1	5/2001	Connolly
5,736,188 A	4/1998	Alcock et al.	6,241,863 B1	6/2001	Monbouquette
5,753,517 A	5/1998	Brooks et al.	6,242,268 B1	6/2001	Wieder et al.
5,770,416 A	6/1998	Lihme et al.	6,255,066 B1	7/2001	Louderback
5,780,308 A	7/1998	Ching et al.	6,258,548 B1 *	7/2001	Buck 435/7.1
5,788,863 A	8/1998	Milunic	6,261,779 B1	7/2001	Barbera-Guillem et al.
5,795,470 A	8/1998	Wang et al.	6,268,222 B1	7/2001	Chandler et al.
5,795,543 A	8/1998	Poto et al.	6,270,637 B1	8/2001	Crismore et al.
5,798,273 A	8/1998	Shuler et al.	6,271,040 B1	8/2001	Buechler
5,811,526 A	9/1998	Davidson	6,274,324 B1	8/2001	Davis et al.
5,827,748 A	10/1998	Golden	6,281,006 B1	8/2001	Heller et al.
5,834,226 A	11/1998	Maupin	6,284,472 B1	9/2001	Wei et al.
5,837,429 A	11/1998	Nohr et al.	6,287,783 B1	9/2001	Maynard et al.
5,837,546 A	11/1998	Allen et al.	6,287,871 B1	9/2001	Herron et al.
5,837,547 A	11/1998	Schwartz	6,294,391 B1	9/2001	Badley et al.
5,843,692 A	12/1998	Phillips et al.	6,294,392 B1	9/2001	Kuhr et al.
5,852,229 A	12/1998	Josse et al.	6,306,665 B1	10/2001	Buck et al.
5,876,944 A	3/1999	Kuo	D450,854 S	11/2001	Lipman et al.
5,885,527 A	3/1999	Buechler	6,331,438 B1	12/2001	Aylott et al.
5,906,921 A	5/1999	Ikedo et al.	6,348,186 B1	2/2002	Sutton et al.
5,910,286 A	6/1999	Lipskier	6,352,862 B1	3/2002	Davis et al.
5,910,447 A	6/1999	Lawrence et al.	6,362,011 B1	3/2002	Massey et al.
5,910,940 A	6/1999	Guerra	6,368,873 B1	4/2002	Chang et al.
5,922,537 A	7/1999	Ewart et al.	6,368,875 B1	4/2002	Geisberg
5,922,550 A	7/1999	Everhart et al.	6,387,707 B1	5/2002	Seul et al.
5,945,281 A	8/1999	Prabhu	6,391,558 B1	5/2002	Henkens et al.
5,951,492 A	9/1999	Douglas et al.	6,399,295 B1	6/2002	Kaylor et al.
5,962,995 A	10/1999	Avnery	6,399,397 B1	6/2002	Zarling et al.
5,968,839 A	10/1999	Blatt et al.	6,399,398 B1	6/2002	Cunningham et al.

6,407,492	B1	6/2002	Avnery et al.	WO	WO 9105999	A2	5/1991
6,411,439	B2	6/2002	Nishikawa	WO	WO 9221769	A1	12/1992
6,413,410	B1	7/2002	Hodges et al.	WO	WO 9221770	A1	12/1992
6,436,651	B1	8/2002	Everhart et al.	WO	WO 9221975	A1	12/1992
6,436,722	B1	8/2002	Clark et al.	WO	WO 9301308	A1	1/1993
6,444,423	B1	9/2002	Meade et al.	WO	WO 9319370	A1	9/1993
6,448,091	B1	9/2002	Massey et al.	WO	WO 9413835	A1	6/1994
6,451,607	B1	9/2002	Lawrence et al.	WO	WO 9415193	A1	7/1994
6,455,861	B1	9/2002	Hoyt	WO	WO 9709620	A1	3/1997
6,461,496	B1	10/2002	Feldman et al.	WO	WO 9910742	A1	3/1999
6,468,741	B1	10/2002	Massey et al.	WO	WO 9930131	A1	6/1999
6,472,226	B1	10/2002	Barradine et al.	WO	WO 9936777	A1	7/1999
6,479,146	B1	11/2002	Caruso et al.	WO	WO 9964864	A1	12/1999
6,509,085	B1	1/2003	Kennedy	WO	WO 0019199	A1	4/2000
6,509,196	B1	1/2003	Brooks et al.	WO	WO 0023805	A1	4/2000
6,511,814	B1	1/2003	Carpenter	WO	WO 0046839	A2	8/2000
6,524,864	B2	2/2003	Fernandez de Castro	WO	WO 0046839	A3	8/2000
6,556,299	B1	4/2003	Rushbrooke et al.	WO	WO 0047983	A1	8/2000
6,566,508	B2	5/2003	Bentsen et al.	WO	WO 0050891	A1	8/2000
6,573,040	B2	6/2003	Everhart et al.	WO	WO 0078917	A1	12/2000
6,579,673	B2	6/2003	McGrath et al.	WO	WO 0138873	A2	5/2001
6,582,930	B1	6/2003	Ponomarev et al.	WO	WO 0163299	A1	8/2001
6,585,939	B1	7/2003	Dapprich	WO	WO 0198765	A1	12/2001
6,607,922	B2	8/2003	LaBorde	WO	WO 0198785	A2	12/2001
6,613,583	B1	9/2003	Richter et al.	WO	WO 0198795	A1	12/2001
6,617,488	B1	9/2003	Springer et al.	WO	WO 03/008971	A2	1/2003
6,627,459	B1	9/2003	Tung et al.	WO	WO 03/008971	A3	1/2003
6,653,149	B1	11/2003	Tung et al.	WO	WO 03005013	A1	1/2003
6,669,908	B2	12/2003	Weyker et al.	WO	WO 200//034056	A3	4/2004
6,670,115	B1	12/2003	Zhang	WO	WO 2004/034056	A2	4/2004
RE38,430	E	2/2004	Rosenstein	WO	WO 2004034056	A2	4/2004
6,720,007	B2	4/2004	Walt et al.	WO	WO 2004034056	A2	4/2004
6,787,368	B1	9/2004	Wong et al.	WO	WO 2004034056	A3	4/2004
6,815,218	B1	11/2004	Jacobson et al.				
6,951,631	B1	10/2005	Catt et al.				
7,044,919	B1	5/2006	Catt et al.				
7,052,831	B2	5/2006	Fletcher et al.				
2001/0055776	A1	12/2001	Greenwalt				
2002/0042149	A1	4/2002	Butlin et al.				
2002/0045273	A1	4/2002	Butlin et al.				
2002/0070128	A1	6/2002	Beckmann				
2002/0146754	A1	10/2002	Kitawaki et al.				
2002/0164659	A1	11/2002	Rao et al.				
2003/0017615	A1	1/2003	Sidwell et al.				
2003/0119202	A1	6/2003	Kaylor et al.				
2003/0119204	A1	6/2003	Wei et al.				
2003/0124739	A1	7/2003	Song et al.				
2003/0162236	A1	8/2003	Harris et al.				
2003/0178309	A1	9/2003	Huang et al.				
2004/0014073	A1	1/2004	Trau et al.				
2004/0043502	A1	3/2004	Song et al.				
2004/0043507	A1	3/2004	Song et al.				
2004/0043511	A1	3/2004	Song et al.				
2004/0106190	A1	6/2004	Yang et al.				
2004/0151632	A1	8/2004	Badley et al.				
2006/0029924	A1	2/2006	Brewster et al.				

FOREIGN PATENT DOCUMENTS

EP	0205698	A1	12/1986
EP	0420053	A1	4/1991
EP	0437287	B1	7/1991
EP	0703454	A1	3/1996
EP	0462376	B1	7/1996
EP	0724156	A1	7/1996
EP	0745843	A2	12/1996
EP	0745843	A3	12/1996
EP	0859230	A1	8/1998
EP	0898169	B1	2/1999
EP	1221616	A1	7/2002
EP	1 255111	A1	11/2002
GB	2273772	A	6/1994
WO	WO 8804777	A1	6/1988

OTHER PUBLICATIONS

Article—*A conductometric biosensor for biosecurity*, Zarini Muhammad-Tahir and Evangelyn C. Alodilja, *Biosensors and Bioelectronics* 18, 2003, pp. 813-819.

Article—*A Disposable Amperometric Sensor Screen Printed on a Nitrocellulose Strip: A Glucose Biosensor Employing Lead Oxide as an InterferenCe-Removing Agent*, Gang Cui, San Jin Kim, Sung Hyuk Choi, Hakhyun Nam, and Geun Sig Cha, *Analytical Chemistry*, vol. 72, No. 8, Apr. 15, 2000, pp. 1925-1929.

Article—*A Fully Active Monolayer Enzyme Electrode Derivatized by Antigen-Antibody Attachment*, Christian Bourdillon, Christopher Demaille, Jean Gueris, Jacques Moiroux, and Jean-Michel Savéant, *J. Am. Chem. Soc.*, vol. 115, No. 26, 1993, pp. 12264-12269.

Article—*A New Tetradentate β -Diketonate-Europium Chelate That Can Be Covalently Bound to Proteins for Time-Resolved Fluoroimmunoassay*, Jingli Yuan and Kazuko Matsumoto, *Analytical Chemistry*, vol. 70, No. 3, Feb. 1, 1998, pp. 596-601.

Article—*A Thermostable Hydrogen Peroxide Sensor Based on "Wiring" of Soybean Peroxidase*, Mark S. Vreeke, Khin Tsun Yong, and Adam Heller, *Analytical Chemistry*, vol. 67, No. 23, Dec. 1, 1995, pp. 4247-4249.

Article—*Acoustic Plate Waves for Measurements of Electrical Properties of Liquids*, U. R. Kelkar, F. Josse, D. T. Haworth, and Z. A. Shana, *Micromechanical Journal*, vol. 43, 1991, pp. 155-164.

Article—*Amine Content of Vaginal Fluid from Untreated and Treated Patients with Nonspecific Vaginitis*, Kirk C.S. Chen, Patricia S. Forsyth, Thomas M. Buchanan, and King K. Holmes, *J. Clin. Invest.*, vol. 63, May 1979, pp. 828-835.

Article—*Analysis of electrical equivalent circuit of quartz crystal resonator loaded with viscous conductive liquids*, *Journal of Electroanalytical Chemistry*, vol. 379, 1994, pp. 21-33.

Article—*Application of rod-like polymers with ionophores as Langmuir-Blodgett membranes for Si-Based ion sensors*, *Sensors & Actuators B*, vol. 6, 1992, pp. 211-226.

Article—*Attempts to Mimic Docking Processes of the Immune System: Recognition of Protein Multilayers*, W. Müller, H. Ringsdorf, E. Rump, G. Wildburg, X. Zhang, L. Angermaier, W. Knoll, M. Liley, and J. Spinke, *Science*, vol. 262, Dec. 10, 1993, pp. 1706-1708.

- Article—*Biochemical Diagnosis of Vaginitis: Determination of Diamines in Vaginal Fluid*, Kirk C.S. Chen, Richard Amsel, David A. Eschenbach, and King K. Holmes, *The Journal of Infectious Diseases*, vol. 145, No. 3, Mar. 1982, pp. 337-345.
- Article—*Biospecific Adsorption of Carbonic Anhydrase to Self-Assembled Monolayers of Alkanethiolates That Present Benzenesulfonamide Groups on Gold*, Milan Mrksich, Jocelyn R. Grunwell, and George M. Whitesides, *J. Am. Chem. Soc.*, vol. 117, No. 48, 1995, pp. 12009-12010.
- Article—*Direct Observation of Streptavidin Specifically Adsorbed on Biotin-Functionalized Self-Assembled Monolayers with the Scanning Tunneling Microscope*, Lukas Häussling, Bruno Michel, Helmut Ringsdorf, and Heinrich Rohrer, *Angew. Chem. Int. Ed. Engl.*, vol. 30, No. 5, 1991, pp. 569-572.
- Article—*Electrical Surface Perturbation of a Piezoelectric Acoustic Plate Mode by a Conductive Liquid Loading*, Fabien Josse, *IEEE Transactions on Ultrasonics, Ferroelectrics, and Frequency Control*, vol. 39, No. 4, Jul. 1992, pp. 512-518.
- Article—*Europium Chelate Labels in Time-Resolved Fluorescence Immunoassays and DNA Hybridization Assays*, Eleftherios P. Diamandis and Theodore K. Christopoulos, *Analytical Chemistry*, vol. 62, No. 22, Nov. 15, 1990, pp. 1149-1157.
- Article—*Evaluation of a Time-Resolved Fluorescence Microscope Using a Phosphorescent Pt-Porphine Model System*, E. J. Hennink, R. de Haas, N. P. Verwoerd, and H. J. Tanke, *Cytometry*, vol. 24, 1996, pp. 312-320.
- Article—*Fabrication of Patterned, Electrically Conducting Polypyrrole Using a Self-Assembled Monolayer: A Route to All-Organic Circuits*, Christopher B. Gorman, Hans A. Biebuyck, and George M. Whitesides, *American Chemical Society*, 2 pages.
- Article—*Fabrication of Surfaces Resistant to Protein Adsorption and Application to Two-Dimensional Protein Patterning*, Suresh K. Bhatia, John L. Teixeira, Mariquita Anderson, Lisa C. Shriver-Lake, Jeffrey M. Calvert, Jacques H. Georger, James J. Hickman, Charles S. Dulcey, Paul E. Schoen, and Frances S. Ligler, *Analytical Biochemistry*, vol. 208, 1993, pp. 197-205.
- Article—*Features of gold having micrometer to centimeter dimensions be formed through a combination of stamping with an elastomeric stamp and an alkanethiol "ink" followed by chemical etching*, Amit Kumar and George M. Whitesides, *Appl. Phys. Lett.*, vol. 63, No. 14, Oct. 4, 1993, pp. 2002-2004.
- Article—*Fine Structure of Human Immunodeficiency Virus (HIV) and Immunolocalization of Structural Proteins*, Hans R. Gelderblom, Elda H.S. Hausmann, Muhsin Özel, George Pauli, and Meinrad A. Koch, *Virology*, vol. 156, No. 1, Jan. 1987, pp. 171-176.
- Article—*Flow-Based Microimmunoassay*, *Analytical Chemistry*, vol. 73, No. 24, Mark A. Hayes, Nolan A. Poison, Allison, N. Phayre, and Antonia A. Garcia, Dec. 15, 2001, pp. 5896-5902.
- Article—*Generation of electrochemically deposited metal patterns by means of electron beam (nano)lithography of self-assembled monolayer resists*, J. A. M. Sondag-Hethorst, H. R. J. van-Helleputte, and L. G. J. Fokink, *Appl. Phys. Lett.*, vol. 64, No. 3, Jan. 17, 1994, pp. 285-287.
- Article—*Heterogeneous Enzyme Immunoassay of Alpha-Fetoprotein in Maternal Serum by Flow-Injection Amperometric Detection of 4-Aminophenol*, Yan Xu, H. Brian Haisall, and William R. Heineman, *Clinical Chemistry*, vol. 36, No. 11, 1990, pp. 1941-1944.
- Article—*Hollow latex particles: synthesis and applications*, Charles J. McDonald and Michael J. Devon, *Advances in Colloid and Interface Science*, Vol. 99, 2002, pp. 181-213.
- Article—*How to Build a Spectrofluorometer*, Spex Fluorolog 3, Horiba Group, pp. 1-14.
- Article—*Hydrogen Peroxide and β -Nicotinamide Adenine Dinucleotide Sensing Amperometric Electrodes Based on Electrical Connection of Horseradish Peroxidase Redox Centers to Electrodes Through a Three-Dimensional Electron Relaying Polymer Network*, Mark Vreeke, Ruben Maidan, and Adam Heller, *Analytical Chemistry*, vol. 64, No. 24, Dec. 15, 1992, pp. 3084-3090.
- Article—*Immunoaffinity Based Phosphorescent Sensor Platform for the Detection of Bacterial Spores*, Peter F. Scholl, C. Brent Barger, Terry E. Phillips, Tonny Wong, Sala Abubaker, John D. Groopman, Paul T. Strickland, and Richard C. Benson, *Proceedings of SPIE*, vol. 3913, 2000, pp. 204-214.
- Article—*Inert Phosphorescent Nanospheres as Markers for Optical Assays*, Jens M. Kümer, Ingo Klimant, Christian Krause, Harald Preu, Werner Kunz, and Otto S. Wolfbeis, *Bioconjugate Chem.*, vol. 12, No. 6, 2001, pp. 883-889.
- Article—*Intelligent Gels*, Yoshihito Osada and Simon B. Ross-Murphy, *Scientific American*, May 1993, pp. 82-87.
- Article—*Latex Immunoassays*, Leigh B. Bangs, *Journal of Clinical Immunoassay*, vol. 13, No. 3, 1990, pp. 127-131.
- Article—*Longwave luminescent porphyrin probes*, Dmitry B. Papkovsky, Gelii P. Ponomarev, and Otto S. Wolfbeis, *Spectrochimica Acta Part A* 52, 1996, pp. 1629-1638.
- Article—*Mechanical resonance gas sensors with piezoelectric excitation and detection using PVDF polymer foils*, R. Block, G. Fickler, G. Lindner, H. Müller, and M. Wohnhas, *Sensors and Actuators B*, 1992, pp. 596-601.
- Article—*Microfabrication by Microcontact Printing Of Self-Assembled Monolayers*, James L. Wilbur, Armit Kumar, Enoch Kim, and George M. Whitesides, *Advanced Materials*, vol. 6, No. 7/8, 1994, pp. 600-604.
- Article—*Modification of monoclonal and polyclonal IgG with palladium (II) coproporphyrin I: stimulatory and inhibitory functional effects induced by two different methods*, Sergey P. Martsev, Valery A. Preygerzon, Yanina I. Mel'nikova, Zinaida I. Kravchulc, Gely V. Ponomarev, Vitaly E. Lunev, and Alexander P. Savitsky, *Journal of Immunological Methods* 186, 1996, pp. 293-304.
- Article—*Molecular Design Temperature-Responsive Polymers as Intelligent Materials*, Teruo Okano, *Advances in Polymer Science*, pp. 179-197.
- Article—*Molecular Gradients of *w*-Substituted Alkanethiols on Gold: Preparation and Characterization*, Bo Liedberg and Pentti Tengvall, *Langmuir*, vol. 11, No. 10, 1995, pp. 3821-3827.
- Article—*Monofunctional Derivatives of Coproporphyrins for Phosphorescent Labeling of Proteins and Binding Assays*, Tomás C. O'Riordan, Aleksii E. Soini, and Dmitri B. Papkovsky, *Analytical Biochemistry*, vol. 290, 2001, pp. 366-375.
- Article—*Nanostructured™ Chemicals: Bridging the Gap Between Fillers, Surface Modifications and Reinforcement*, Joseph D. Lichtenhan, *Invited lectures: Functional Tire Fillers 2001*, Ft. Lauderdale, FL, Jan. 29-31, 2001, pp. 1-15.
- Article—*Near Infrared Phosphorescent Metalloporphyrins*, Alexander P. Savitsky Anna V. Savitskaja, Eugeny A. Lukjanetz, Svetlana N. Dashkevich, and Elena A. Malcarova, *SPIE*, vol. 2980, pp. 352-357.
- Article—*New Approach To Producing Patterned Biomolecular Assemblies*, Suresh K. Bhatia, James J. Hickman, and Frances S. Ligler, *J. Am. Chem. Soc.*, vol. 114, 1992, pp. 4433-4434.
- Article—*On the use of ZX-LiNbO₃ acoustic plate mode devices as detectors for dilute electrolytes*, F. Josse, Z. A. Shana, D. T. Haworth, and S. Liew, *Sensors and Actuators B*, vol. 9, 1992, pp. 92-112.
- Article—*One-step all-in-one dry reagent immunoassays with fluorescent europium chelate label and time-resolved fluorometry*, Timo Lövgren, Liisa Meriö, Katja Mitrunen, Maija-Liisa Mäkinen, Minna Mäkelä, Kaj Blomberg, Tom Palenius, and Kim Pettersson, *Clinical Chemistry* 42:8, 1996, pp. 1196-1201.
- Article—*Optical Biosensor Assay (OBATM)*, Y. G. Tsay, C. I. Lin, J. Lee, E. K. Gustafson, R. Appelqvist, P. Maggini, R. Norton, N. Teng, and D. Charlton, *Clinical Chemistry*, vol. 37, No. 9, 1991, pp. 1502-1505.
- Article—*Order in Microcontact Printed Self-Assembled Monolayers*, N. B. Larsen, H. Biebuyck, E. Delamar, and B. Michel, *J. Am. Chem. Soc.*, vol. 119, No. 13, 1997, pp. 3017-3026.
- Article—*Orientation dependence of surface segregation in a dilute Ni-Au alloy*, W. C. Johnson, N. G. Chavka, R. Ku, J. L. Bomback, and P. P. Wynblatt, *J. Vac. Sci. Technol.* vol. 15, No. 2, Mar./Apr. 1978, pp. 467-469.
- Article—*Patterned Condensation Figures as Optical Diffraction Gratings*, Amit Kumar and George M. Whitesides, *Science*, vol. 263, Jan. 7, 1994, pp. 60-62.
- Article—*Patterned Functionalization of Gold and Single Crystal Silicon via Photochemical Reaction of Surface-Confined Derivatives*

- of ($n^5\text{-C}_2\text{H}_5$) $\text{Mn}(\text{CO})_3$, Doris Kang and Mark S. Wrighton, *Langmuir*, vol. 7, No. 10, 1991, pp. 2169-2174.
- Article—*Patterned Metal Electrodeposition Using an Alkanethiolate Mask*, T. P. Moffat and H. Yang, *J. Electrochem. Soc.*, vol. 142, No. 11, Nov. 1995, pp. L220-L222.
- Article—*Performance Evaluation of the Phosphorescent Porphyrin Label: Solid-Phase Immunoassay of α -Fetoprotein*, Tomás C. O'Riordan, Aleksí E. Soini, Juhani T. Soini, and Dmitri B. Papkovsky, *Analytical Chemistry*, vol. 74, No. 22, Nov. 15, 2002, pp. 5845-5850.
- Article—*Phosphorescent porphyrin probes in biosensors and sensitive bioassays*, D. B. Papkovsky, T. O'Riordan, and A. Soini, *Biochemical Society Transactions*, vol. 28, part 2, 2000, pp. 74-77.
- Article—*Photopatterning and Selective Electroless Metallization of Surface-Attached Ligands*, Walter J. Dressick, Charles S. Dulcey, Jacque H. Georger, Jr., and Jeffrey M. Calvert, *American Chemical Society*, 2 pages.
- Article—*Photosensitive Self-Assembled Monolayers on Gold: Photochemistry of Surface-Confining Aryl Azide and Cyclopentadienylmanganese Tricarbonyl*, Eric W. Wollman, Doris Kang, C. Daniel Frisbie, Ivan M. Lorkovic and Mark S. Wrighton, *J. Am. Chem. Soc.*, vol. 116, No. 10, 1994, pp. 4395-4404.
- Article—*Polymer Based Lanthanide Luminescent Sensors for the Detection of Nerve Agents*, Amanda L. Jenkins, O. Manuel Uy, and George M. Murray, *Analytical Communications*, vol. 34, Aug. 1997, pp. 221-224.
- Article—*Prediction of Segregation to Alloy Surfaces from Bulk Phase Diagrams*, J. J. Burton and E. S. Machlin, *Physical Review Letters*, vol. 37, No. 21, Nov. 22, 1976, pp. 1433-1436.
- Article—*Principle and Applications of Size-Exclusion Chromatography*, Impact Analytical, pp. 1-3.
- Article—*Probing of strong and weak electrolytes with acoustic wave fields*, R. Dahint, D. Grunze, F. Josse, and J. C. Andle, *Sensors and Actuators B*, vol. 9, 1992, pp. 155-162.
- Article—*Production of Hollow Microspheres from Nanostructured Composite Particles*, Frank Caruso, Rachel A. Caruso, and Helmuth Möhwald, *Chem. Mater.*, vol. 11, No. 11, 1999, pp. 3309-3314.
- Article—*Quantitative Prediction of Surface Segregation*, M. P. Seah, *Journal of Catalysts*, vol. 57, 1979, pp. 450-457.
- Article—*Quartz Crystal Resonators as Sensors in Liquids Using the Acoustoelectric Effect*, Zack A. Shana and Fabian Josse, *Analytical Chemistry*, vol. 66, No. 13, Jul. 1, 1994, pp. 1955-1964.
- Article—*Responsive Gels: Volume Transitions I*, M. Ilavský, H. Inomata, A. Khokhlova, M. Konno, A. Onuki, S. Saito, M. Shibayama, R.A. Siegel, S. Starodubtzev, T. Tanaka, and V. V. Vasilivskaya, *Advances in Polymer Science*, vol. 109, 9 pages.
- Article—*Room-Temperature Phosphorescent Palladium-Porphine Probe for DNA Determination*, Montserrat Roza-Fernández, María Jesús Valencia-González, and Marta Elena Diaz-García, *Analytical Chemistry*, vol. 69, No. 13, Jul. 1, 1997, pp. 2406-2410.
- Article—*Self-Assembled Monolayer Films For Nanofabrication*, Elizabeth A. Dobisz, F. Keith Perkins, Susan L. Brandow, Jeffrey M. Calvert, and Christie R. K. Marrian, *Mat. Res. Soc. Symp. Proc.*, vol. 380, 1995, pp. 23-34.
- Article—*Sensing liquid properties with thickness-shear mode resonators*, S. J. Martin, G. C. Frye, and K. O. Wessendorf, *Sensors and Actuators A*, vol. 44, 1994, pp. 209-218.
- Article—*Separation-Free Sandwich Enzyme Immunoassays Using Microporous Gold Electrodes and Self-Assembled Monolayer/Immobilized Capture Antibodies*, Chuanming Duan and Mark E. Meyerhoff, *Analytical Chemistry*, vol. 66, No. 9, May 1, 1994, pp. 1369-1377.
- Article—*Solid Substrate Phosphorescent Immunoassay Based On Biocoupled Nanoparticles*, Gaoquan Sun, Guangshun Yi, Shuying Zhao, Depu Chen, Yuxiang Zhou, and Jing Cheng, *Analytical Letters*, vol. 34, 2001, pp. 1627-1637.
- Article—*Stimuli-Responsive Poly(N-isopropylacrylamide) Photo- and Chemical-Induced Phase Transitions*, *Advances in Polymer Science*, pp. 50-65.
- Article—*The Adsorptive Characteristics of Proteins for Polystyrene and Their Significance in Solid-Phase Immunoassays*, L. A. Cantaero, J. E. Butler, and J. W. Osborne, *Analytical Biochemistry*, vol. 105, 1980, pp. 375-382.
- Article—*The Use of Self-Assembled Monolayers and a Selective Etch To Generate Patterned Gold Features*, Amit Kumar, Hans A. Biebuyck, Nicholas L. Abbott, and George M. Whitesides, *Journal of the American Chemical Society*, vol. 114, 1992, 2 pages.
- Article—*Volume Phase Transition of N-Alkylacrylamide Gels*, S. Saito, M. Konno, and H. Inomata, *Advances in Polymer Science*, vol. 109, 1992, pp. 207-232.
- Article—*Whole Blood Capcellia CD4/CD8 Immunoassay for Enumeration of CD4+ and CD8+ Peripheral T Lymphocytes*, Dominique Carrière, Jean Pierre Vendrell, Claude Fontaine, Aline Jansen, Jacques Reynes, Isabelle Pagès, Catherine Holzmann, Michel Laprade, and Bernard Pau, *Clinical Chemistry*, vol. 45, No. 1, 1999, pp. 92-97.
- 8 Photographs of Accu-chek® Blood Glucose Meter.
- AMI Screen Printers—Product Information, 4 pages.
- CELQUAT® SC-230M (28-6830).
- CELQUAT® SC-240C and SC-230M, from National Starch & Chemical, 1 page.
- Polyquaternium-10, from National Starch & Chemical, 1 page.
- Dualita® Polymeric Microspheres, from Pierce & Stevens Corp. a subsidiary of Sovereign Specialty Chemicals, Inc., 2 pages.
- Dynabeads® Biomagnetic Separation Technology—The Principle from Dynal Biotech, 2 pages.
- ECCOSPHERES® glass microspheres—hollow glass microspheres from Emerson & Cuming Composite Materials, Inc., 1 page.
- Fluorescent Microsphere Standards for Flow Cytometry and Fluorescence Microscopy from Molecular Probes, pp. 1-8.
- FluoSpheres® Fluorescent Microspheres, Product Information from Molecular Probes, Mar. 13, 2001, pp. 1-6.
- Magnetic Microparticles, Polysciences, Inc. Technical Data Sheet 438, 2 pages.
- Making sun exposure safer for everyone from Rohm and Haas Company (Bristol Complex), 2 pages.
- Pamphlet—The ClearPlane® Easy Fertility Monitor.
- POSS Polymer Systems from Hybrid Plastics, 3 pages.
- The colloidal state, Introduction to Colloid and Surface Chemistry, 4th Ed., 17 pages.
- Working With FluoSpheres® Fluorescent Microspheres, Properties and Modifications, Product Information from Molecular Probes, Mar. 9, 2001, pp. 1-5.
- PCT Search Report for PCT/US03/21520, Dec. 15, 2003.
- PCT Search Report for PCT/US02/37653, Apr. 7, 2004.
- PCT Search Report for PCT/US03/28628, Mar. 18, 2004.
- PCT Search Report for PCT/US03/34543, Apr. 6, 2004.
- PCT Search Report for PCT/US03/34544, Apr. 20, 2004.
- PCT Search Report and Written Opinion for PCT/US2004/013180, Aug. 17, 2004.
- Wei, et al., U.S. Appl. No. 10/325,429, filed Dec. 19, 2002, Self-Calibrated Flow-Through Assay Devices.
- Yang, et al., U.S. Appl. No. 10/406,577, filed Apr. 3, 2003, Assay Devices That Utilize Hollow Particles.
- Wei, et al., U.S. Appl. No. 10/325,614, filed Dec. 19, 2002, Reduction Of The Hook Effect In Membrane-Based Assay Devices.
- Wei, et al., U.S. Appl. No. 10/406,631, filed Apr. 3, 2003, Reduction Of The Hook Effect In Assay Devices.
- Wei, et al., U.S. Appl. No. 10/718,997, filed Nov. 21, 2003, Extension Of The Dynamic Detection Range Of Assay Devices.
- Xuedong Song, U.S. Appl. No. 10/719,976, filed Nov. 21, 2003, Method For Extending The Dynamic Detection Range Of Assay Devices.
- Yang, et al., U.S. Appl. No. 10/741,434, filed Dec. 19, 2003, Laminated Assay Devices.
- Yang, et al., U.S. Appl. No. 10/742,589, filed Dec. 19, 2003, Flow Control Of Electrochemical-Based Assay Devices.
- Yang, et al., U.S. App. No. 10/742,590, filed Dec. 19, 2003, Flow-Through Assay Devices.
- Xuedong Song, U.S. Appl. No. 10/718,989, filed Nov. 21, 2003, Membrane-Based Lateral Flow Assay Devices That Utilize Phosphorescent Detection.
- David S. Cohen, U.S. Appl. No. 10/836,093, filed Apr. 30, 2004, Optical Detection Systems.
- Boga, et al., U.S. Appl. No. 10/790,617, filed Mar. 1, 2004, Assay Devices Utilizing Chemichronic Dyes.

Article—*New Use of Cyanosilane Coupling Agent for Direct Binding of Antibodies to Silica Supports. Physicochemical Characterization of Molecularly bioengineered Layers*, Sandrine Falipou, Jean-Marc Chovelon, Claude Martelet, Jacqueline Margonari and Dominique Cathignol, *Bioconjugate Chem.*, vol. 10, No. 3, 1999, pp. 346-353.

PCT Search Report and Written Opinion for PCT/US2004/006412, Sep. 28, 2004.

PCT Search Report and Written Opinion for PCT/US2004/006414, Sep. 28, 2004.

PCT Search Report and Written Opinion for PCT/US2004/032938, Jan. 21, 2005.

Article—*Application of rod-like polymers with ionophores as Langmuir-Blodgett membranes for Si-Based ion sensors*, *Sensors & Actuators B*, vol. 6, 1992, pp. 211-216.

Article—*Photolithography of self-assembled monolayers: optimization of protecting groups by an electroanalytical method*, *Can.J. Chem.* vol. 74, 1996, pp. 2509-2517.

* cited by examiner

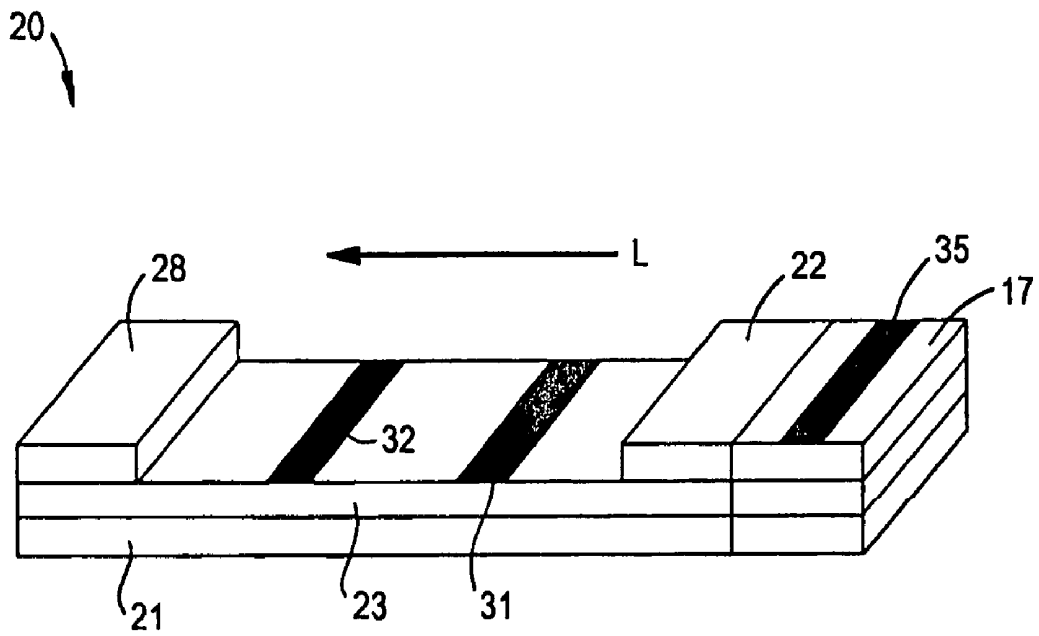

FIG. 1

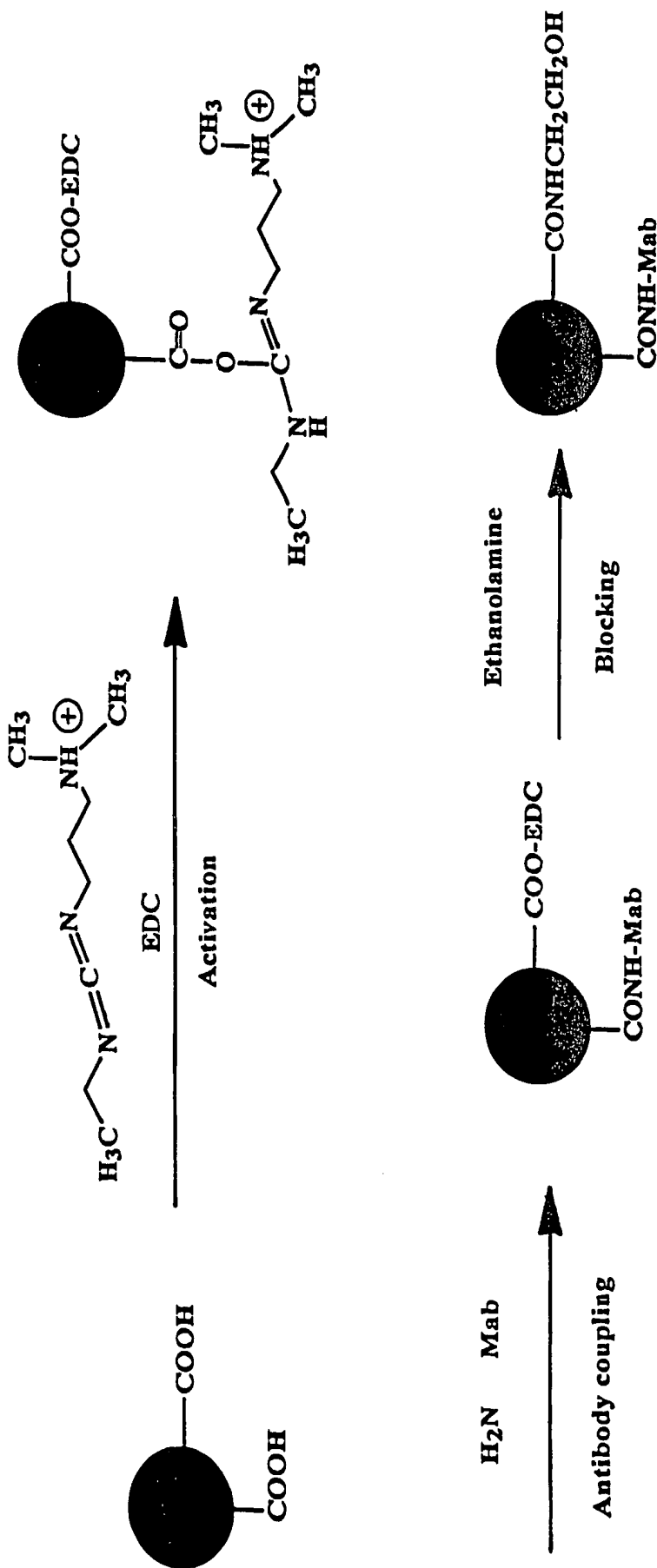

FIG. 2

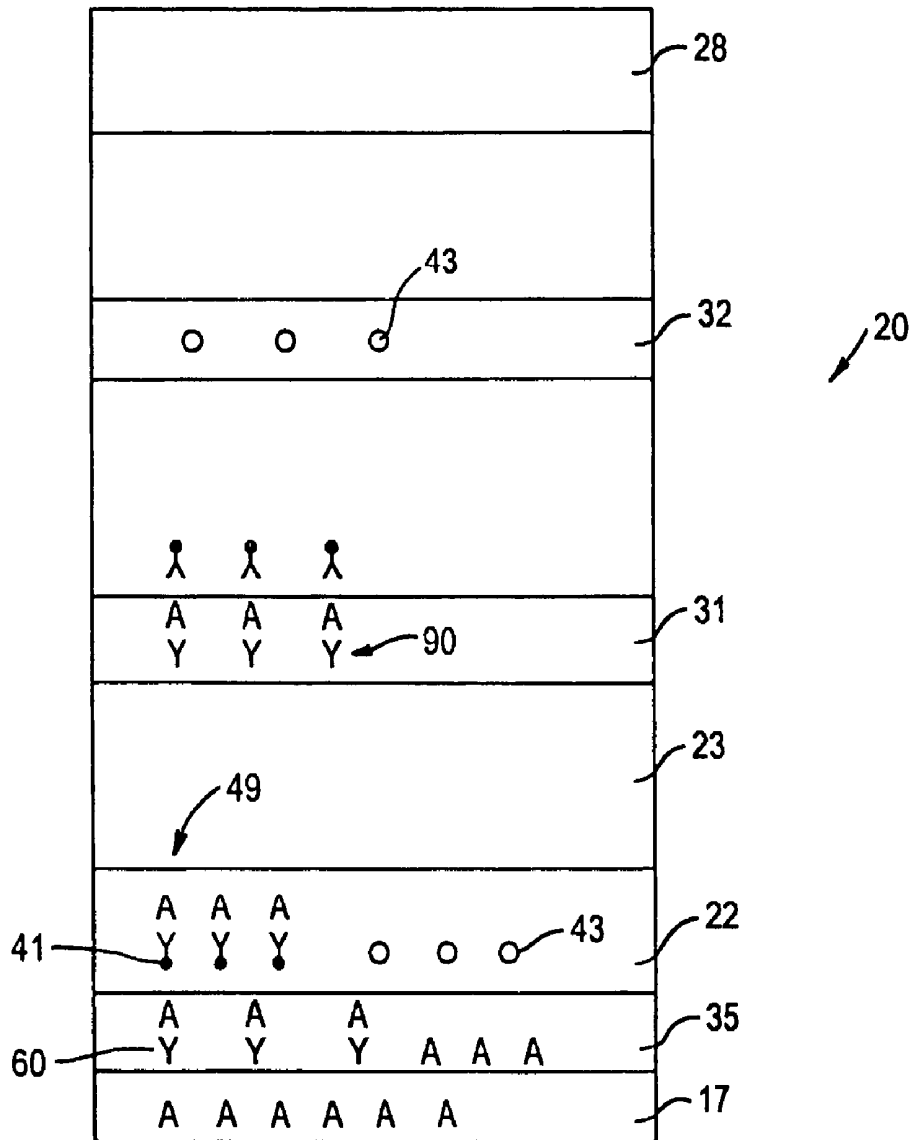

FIG. 3

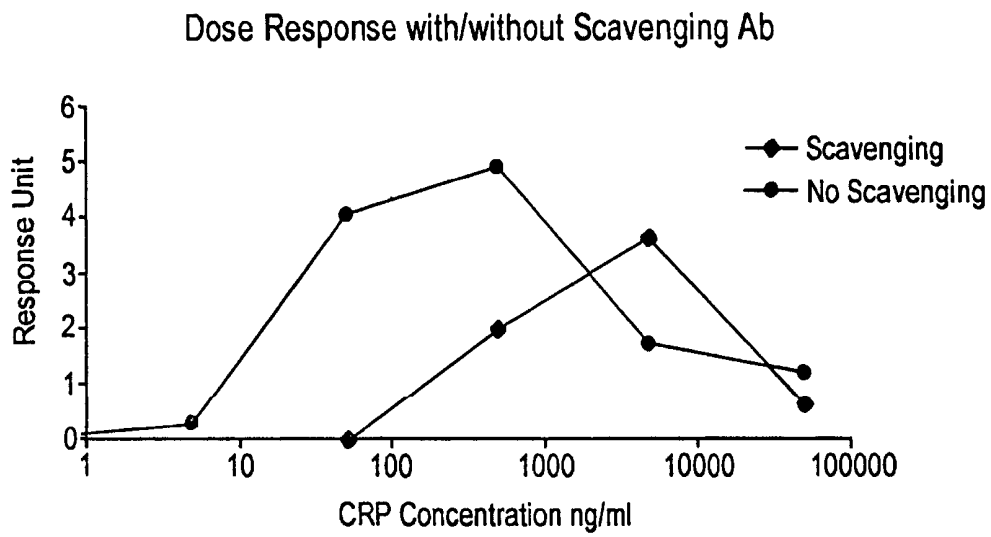

FIG. 4

METHOD OF REDUCING THE SENSITIVITY OF ASSAY DEVICES

BACKGROUND OF THE INVENTION

Various analytical procedures and devices are commonly employed in flow-through assays to determine the presence and/or concentration of analytes that within a test sample. For instance, immunoassays utilize mechanisms of the immune systems, wherein antibodies are produced in response to the presence of antigens that are pathogenic or foreign to the organisms. These antibodies and antigens, i.e., immunoreactants, are capable of binding with one another, thereby causing a highly specific reaction mechanism that may be used to determine the presence or concentration of that particular antigen in a biological sample. Unfortunately, many conventional immunoassay assays encounter problems when used to measure test samples that possess a high analyte concentration. For instance, elevated levels of C-reactive protein ("CRP") are sometimes indicative of certain diseases, such as heart disease. However, even normal blood samples may contain a high CRP concentration, often within the "milligrams per milliliter" range. Because most conventional immunoassays are designed to detect analyte concentrations in the "nanograms per milliliter" range, they will almost undoubtedly give positive results of the presence of CRP for all test samples, including those having a normal CRP concentration. This may be particularly troubling to consumers who are themselves performing the assay with a disposable device.

As such, a need currently exists for an assay device that is capable of detecting the presence of an analyte in circumstances where a "normal" test sample still contains relatively high levels of the analyte.

SUMMARY OF THE INVENTION

In accordance with one embodiment of the present invention, a method for detecting an analyte residing in a test sample is disclosed. The method comprises:

i) providing a flow-through assay device comprising a porous membrane that is in fluid communication with detection probes conjugated with a specific binding member for the analyte, wherein the assay device defines a scavenging zone and a detection zone, each of the zones containing a capture reagent for the analyte;

ii) contacting the scavenging zone with the test sample so that a quantity of the analyte less than or equal to a predefined base quantity binds to the capture reagent at the scavenging zone;

iii) contacting the conjugated detection probes with the test sample; and

iv) allowing the test sample and the conjugated detection probes to flow to the detection zone so that the conjugated detection probes or complexes thereof bind to the capture reagent and generate a detection signal, wherein the quantity of analyte in the test sample in excess of the predefined base quantity is proportional to the intensity of the detection signal.

In accordance with another embodiment of the present invention, a method for detecting an antigen residing in a test sample is disclosed. The method comprises:

i) providing a flow-through assay device comprising a porous membrane that is in fluid communication with detection probes conjugated with a specific binding member for the antigen, wherein the assay device defines a scavenging zone and a detection zone located downstream from the scavenging zone, each of the zones containing a capture reagent

capable of specifically binding to the antigen, wherein the capture reagent of the scavenging zone includes an antibody;

ii) contacting the scavenging zone with the test sample so that a quantity of the antigen less than or equal to a predefined base quantity binds to the antibody at the scavenging zone;

iii) thereafter, contacting the conjugated detection probes with the test sample; and

iv) allowing the test sample and the conjugated detection probes to bind to the capture reagent at the detection zone and generate a detection signal, wherein the quantity of antigen in the test sample in excess of the predefined base quantity is proportional to the intensity of the detection signal.

In accordance with still another embodiment of the present invention, a flow-through assay device is disclosed for detecting an analyte residing in a test sample. The assay device comprises a porous membrane that is in fluid communication with detection probes conjugated with a specific binding member for the analyte. The assay device defines a scavenging zone that contains a capture reagent configured to bind to a quantity of the analyte less than or equal to a predefined base quantity. The assay device further defines a detection zone within which a capture reagent is immobilized that is configured to bind to the conjugated detection probes or complexes of the conjugated detection probes and any analyte that does not bind to the scavenging zone. The detection zone is configured to generate a detection signal so that the quantity of analyte in the test sample in excess of the predefined base quantity is proportional to the intensity of the detection signal.

Other features and aspects of the present invention are discussed in greater detail below.

BRIEF DESCRIPTION OF THE DRAWINGS

A full and enabling disclosure of the present invention, including the best mode thereof, directed to one of ordinary skill in the art, is set forth more particularly in the remainder of the specification, which makes reference to the appended figures in which:

FIG. 1 is a perspective view of one embodiment of a flow-through assay device of the present invention;

FIG. 2 is a graphical illustration of one embodiment for covalently conjugating an antibody to a detection probe;

FIG. 3 is a graphical illustration of the mechanism used for one embodiment of a sandwich assay format of the present invention; and

FIG. 4 shows the results of Example 2, in which the intensity of the detection line for an assay using a scavenging zone was compared to the intensity of the detection line for an assay without a scavenging zone.

Repeat use of reference characters in the present specification and drawings is intended to represent same or analogous features or elements of the invention.

DETAILED DESCRIPTION OF REPRESENTATIVE EMBODIMENTS

Definitions

As used herein, the term "analyte" generally refers to a substance to be detected. For instance, analytes may include antigenic substances, haptens, antibodies, and combinations thereof. Analytes include, but are not limited to, toxins, organic compounds, proteins, peptides, microorganisms, amino acids, nucleic acids, hormones, steroids, vitamins, drugs (including those administered for therapeutic purposes as well as those administered for illicit purposes), drug inter-

mediaries or byproducts, bacteria, virus particles and metabolites of or antibodies to any of the above substances. Specific examples of some analytes include ferritin; creatinine kinase MB (CK-MB); digoxin; phenytoin; phenobarbital; carbamazepine; vancomycin; gentamycin; theophylline; valproic acid; quinidine; luteinizing hormone (LH); follicle stimulating hormone (FSH); estradiol, progesterone; C-reactive protein; lipocalins; IgE antibodies; cytokines; vitamin B2 microglobulin; glycated hemoglobin (Gly. Hb); cortisol; digitoxin; N-acetylprocainamide (NAPA); procainamide; antibodies to rubella, such as rubella-IgG and rubella IgM; antibodies to toxoplasmosis, such as toxoplasmosis IgG (Toxo-IgG) and toxoplasmosis IgM (Toxo-IgM); testosterone; salicylates; acetaminophen; hepatitis B virus surface antigen (HBsAg); antibodies to hepatitis B core antigen, such as anti-hepatitis B core antigen IgG and IgM (Anti-HBC); human immune deficiency virus 1 and 2 (HIV 1 and 2); human T-cell leukemia virus 1 and 2 (HTLV); hepatitis B e antigen (HBeAg); antibodies to hepatitis B e antigen (Anti-HBe); influenza virus; thyroid stimulating hormone (TSH); thyroxine (T4); total triiodothyronine (Total T3); free triiodothyronine (Free T3); carcinoembryonic antigen (CEA); lipoproteins, cholesterol, and triglycerides; and alpha fetoprotein (AFP). Drugs of abuse and controlled substances include, but are not intended to be limited to, amphetamine; methamphetamine; barbiturates, such as amobarbital, secobarbital, pentobarbital, phenobarbital, and barbital; benzodiazepines, such as librium and valium; cannabinoids, such as hashish and marijuana; cocaine; fentanyl; LSD; methaqualone; opiates, such as heroin, morphine, codeine, hydromorphone, hydrocodone, methadone, oxycodone, oxymorphone and opium; phencyclidine; and propoxyphene. Other potential analytes may be described in U.S. Pat. No. 6,436,651 to Everhart, et al. and U.S. Pat. No. 4,366,241 to Tom et al.

As used herein, the term "test sample" generally refers to a material suspected of containing the analyte. The test sample may be used directly as obtained from the source or following a pretreatment to modify the character of the sample. The test sample may be derived from any biological source, such as a physiological fluid, including, blood, interstitial fluid, saliva, ocular lens fluid, cerebral spinal fluid, sweat, urine, milk, ascites fluid, mucous, synovial fluid, peritoneal fluid, vaginal fluid, amniotic fluid or the like. The test sample may be pretreated prior to use, such as preparing plasma from blood, diluting viscous fluids, and the like. Methods of treatment may involve filtration, precipitation, dilution, distillation, mixing, concentration, inactivation of interfering components, and the addition of reagents. Besides physiological fluids, other liquid samples may be used such as water, food products and the like for the performance of environmental or food production assays. In addition, a solid material suspected of containing the analyte may be used as the test sample. In some instances it may be beneficial to modify a solid test sample to form a liquid medium or to release the analyte.

DETAILED DESCRIPTION

Reference now will be made in detail to various embodiments of the invention, one or more examples of which are set forth below. Each example is provided by way of explanation of the invention, not limitation of the invention. In fact, it will be apparent to those skilled in the art that various modifications and variations may be made in the present invention without departing from the scope or spirit of the invention. For instance, features illustrated or described as part of one embodiment, may be used on another embodiment to yield a

still further embodiment. Thus, it is intended that the present invention covers such modifications and variations as come within the scope of the appended claims and their equivalents.

In general, the present invention is directed to a flow-through assay device for detecting an analyte residing in a test sample. The device utilizes a scavenging zone that contains a capture reagent for the analyte of interest. The capture reagent may capture a quantity of the analyte that is less than or equal to a predefined base quantity of the analyte, such as a quantity considered "normal" for a particular test sample. Thus, the capture reagent is able to prevent some of the analyte from being detected. In this manner, the sensitivity of the assay device may be reduced in a simple, inexpensive, yet effective manner.

Referring to FIG. 1, for instance, one embodiment of a flow-through assay device **20** that may be formed according to the present invention will now be described in more detail. As shown, the device **20** contains a porous membrane **23** optionally supported by a rigid material **21**. In general, the porous membrane **23** may be made from any of a variety of materials through which the test sample is capable of passing. For example, the materials used to form the porous membrane **23** may include, but are not limited to, natural, synthetic, or naturally occurring materials that are synthetically modified, such as polysaccharides (e.g., cellulose materials such as paper and cellulose derivatives, such as cellulose acetate and nitrocellulose); polyether sulfone; polyethylene; nylon; polyvinylidene fluoride (PVDF); polyester; polypropylene; silica; inorganic materials, such as deactivated alumina, diatomaceous earth, MgSO₄, or other inorganic finely divided material uniformly dispersed in a porous polymer matrix, with polymers such as vinyl chloride, vinyl chloride-propylene copolymer, and vinyl chloride-vinyl acetate copolymer; cloth, both naturally occurring (e.g., cotton) and synthetic (e.g., nylon or rayon); porous gels, such as silica gel, agarose, dextran, and gelatin; polymeric films, such as polyacrylamide; and the like. In one particular embodiment, the porous membrane **23** is formed from nitrocellulose and/or polyether sulfone materials. It should be understood that the term "nitrocellulose" refers to nitric acid esters of cellulose, which may be nitrocellulose alone, or a mixed ester of nitric acid and other acids, such as aliphatic carboxylic acids having from 1 to 7 carbon atoms.

The device **20** may also contain a wicking pad **28**. The wicking pad **28** generally receives fluid that has migrated through the entire porous membrane **23**. As is well known in the art, the wicking pad **28** may assist in promoting capillary action and fluid flow through the membrane **23**.

To initiate the detection of an analyte within the test sample, a user may apply the test sample to a portion of the porous membrane **23** (either directly or indirectly) through which it may then travel in the direction illustrated by arrow "L" in FIG. 1. For example, as shown, the test sample is applied to a sampling pad **17** that is in fluid communication with the porous membrane **23**. Some suitable materials that may be used to form the sampling pad **17** include, but are not limited to, nitrocellulose, cellulose, porous polyethylene pads, and glass fiber filter paper.

The sampling pad **17** contains a scavenging zone **35**. Alternatively, the scavenging zone **35** may be formed directly on the porous membrane **23**, or at any other location of the assay device **20**. Regardless of its location, the scavenging zone **35** includes one or more capture reagents having a specific binding member for the analyte of interest. A specific binding member generally refers to a member of a specific binding pair, i.e., two different molecules where one of the molecules chemically and/or physically binds to the second molecule.

For example, in some embodiments, the capture reagent may include antigens, haptens, protein A or G, neutravidin, avidin, streptavidin, captavidin, antibodies (e.g., polyclonal, monoclonal, etc.), and complexes thereof. When utilized, the antibody may be a monoclonal or polyclonal antibody, a recombinant protein or a mixture(s) or fragment(s) thereof, as well as a mixture of an antibody and other specific binding members. The details of the preparation of such antibodies and their suitability for use as specific binding members are well known to those skilled in the art. Other common specific binding pairs include but are not limited to, biotin and avidin (or derivatives thereof), biotin and streptavidin, carbohydrates and lectins, complementary nucleotide sequences (including probe and capture nucleic acid sequences used in DNA hybridization assays to detect a target nucleic acid sequence), complementary peptide sequences including those formed by recombinant methods, effector and receptor molecules, hormone and hormone binding protein, enzyme cofactors and enzymes, enzyme inhibitors and enzymes, and so forth. Furthermore, specific binding pairs may include members that are analogs of the original specific binding member. For example, a derivative or fragment of the analyte, i.e., an analyte-analog, may be used so long as it has at least one epitope in common with the analyte.

The capture reagent of the scavenging zone **35** serves as a binding site for the analyte. Specifically, analytes, such as antigens, typically have two or more binding sites (e.g., epitopes). One of these binding sites binds to the capture reagent at the scavenging zone **35**. Desirably, the capture reagent is immobilized (diffusively or non-diffusively) within the scavenging zone **35** to prohibit the analyte from later being captured at the detection zone **31** (discussed below). Alternatively, however, the capture reagent may simply be formed from a compound that will not be captured at the detection zone **31**. For example, the capture reagent may be identical to an additional capture reagent used at the detection zone **31**. In this manner, the capture reagent at the scavenging zone **35** will occupy the only epitope of the analyte that would be able to bind to the capture reagent at the detection zone **31**.

The scavenging zone **35** may generally provide any number of distinct regions (e.g., lines, dots, etc.). Each region may contain the same capture reagent, or may contain different capture reagents for capturing multiple analytes. The regions may be disposed in the form of lines in a direction that is substantially perpendicular to the flow of the test sample through the assay device **20**. Likewise, in some embodiments, the regions may be disposed in the form of lines in a direction that is substantially parallel to the flow of the test sample through the assay device **20**. Regardless of the particular configuration of the scavenging zone **35** selected, the quantity of the capture reagent at the scavenging zone **35** is predetermined and tailored to capture a quantity of the analyte that is less than or equal to a predefined base quantity, such as a quantity considered "normal" for the particular application. For instance, a blood sample containing less than about 10 micrograms of C-reactive protein ("CRP") per milliliter may be considered "normal" under some circumstances. In this case, the quantity of CRP-specific antibodies utilized at the scavenging zone **35** may be sufficient to bind to a maximum of 10 micrograms per milliliter of CRP. Any additional CRP will pass through the scavenger zone **35** and be detected at the detection zone **31** (discussed below).

Referring again to FIG. 1, the test sample (including any free analyte) travels from the sampling pad **17** to a conjugate pad **22** that is in fluid communication with at least one end of the sampling pad **17**. The conjugate pad **22** is formed from a material through which the test sample is capable of passing.

For example, in one embodiment, the conjugate pad **22** is formed from glass fibers. Although only one conjugate pad **22** is shown, it should be understood that other conjugate pads may also be used in the present invention.

To facilitate accurate detection of the presence or absence of any remaining analyte within the test sample, a predetermined amount of detection probes are applied at various locations of the device **20**. Any substance generally capable of generating a signal that is detectable visually or by an instrumental device may be used as detection probes. Various suitable substances may include chromogens; catalysts; luminescent compounds (e.g., fluorescent, phosphorescent, etc.); radioactive compounds; direct visual labels, including colloidal metallic (e.g., gold) and non-metallic particles, dye particles, enzymes or substrates, or organic polymer latex particles; liposomes or other vesicles containing signal producing substances; and so forth. For instance, some enzymes suitable for use as detection probes are disclosed in U.S. Pat. No. 4,275,149 to Litman, et al., which is incorporated herein in its entirety by reference thereto for all purposes. Some examples of suitable fluorescent molecules, for instance, include, but are not limited to, fluorescein, europium chelates, phycobiliprotein, rhodamine and their derivatives and analogs. Other suitable detection probes may be described in U.S. Pat. No. 5,670,381 to Jou, et al. and U.S. Pat. No. 5,252,459 to Tarcha, et al., which are incorporated herein in their entirety by reference thereto for all purposes.

The detection probes, such as described above, may be used alone or in conjunction with a particle (sometimes referred to as "beads"). For instance, naturally occurring particles, such as nuclei, mycoplasma, plasmids, plastids, mammalian cells (e.g., erythrocyte ghosts), unicellular microorganisms (e.g., bacteria), polysaccharides (e.g., agarose), and so forth, may be used. Further, synthetic particles may also be utilized. For example, in one embodiment, latex particles that are labeled with a fluorescent or colored dye are utilized. Although any latex particle may be used in the present invention, the latex particles are typically formed from polystyrene, butadiene styrenes, styreneacrylic-vinyl terpolymer, polymethylmethacrylate, polyethyl methacrylate, styrene-maleic anhydride copolymer, polyvinyl acetate, polyvinylpyridine, polydivinylbenzene, polybutyleneterephthalate, acrylonitrile, vinylchloride-acrylates, and so forth, or an aldehyde, carboxyl, amino, hydroxyl, or hydrazide derivative thereof. Other suitable particles may be described in U.S. Pat. No. 5,670,381 to Jou, et al. and U.S. Pat. No. 5,252,459 to Tarcha, et al., which are incorporated herein in their entirety by reference thereto for all purposes. Commercially available examples of suitable fluorescent particles include fluorescent carboxylated microspheres sold by Molecular Probes, Inc. under the trade names "FluoSphere" (Red 580/605) and "TransfluoSphere" (543/620), as well as "Texas Red" and 5- and 6-carboxytetramethylrhodamine, which are also sold by Molecular Probes, Inc. In addition, commercially available examples of suitable colored, latex particles include carboxylated latex beads sold by Bang's Laboratory, Inc.

When utilized, the shape of the particles may generally vary. In one particular embodiment, for instance, the particles are spherical in shape. However, it should be understood that other shapes are also contemplated by the present invention, such as plates, rods, discs, bars, tubes, irregular shapes, etc. In addition, the size of the particles may also vary. For instance, the average size (e.g., diameter) of the particles may range from about 0.1 nanometers to about 1,000 microns, in some embodiments, from about 0.1 nanometers to about 100 microns, and in some embodiments, from about 1 nanometer to about 10 microns. For instance, "micron-scale" particles

are often desired. When utilized, such “micron-scale” particles may have an average size of from about 1 micron to about 1,000 microns, in some embodiments from about 1 micron to about 100 microns, and in some embodiments, from about 1 micron to about 10 microns. Likewise, “nano-scale” particles may also be utilized. Such “nano-scale” particles may have an average size of from about 0.1 to about 10 nanometers, in some embodiments from about 0.1 to about 5 nanometers, and in some embodiments, from about 1 to about 5 nanometers.

In some instances, the detection probes are modified in some manner so that they are more readily able to bind to the analyte. In such instances, the detection probes may be modified with specific binding members that are adhered thereto to form conjugated probes. These specific binding members may be the same or different than the specific binding members described above. Specific binding members may generally be attached to detection probes using any of a variety of well-known techniques. For instance, covalent attachment of specific binding members to the detection probes (e.g., particles) may be accomplished using carboxylic, amino, aldehyde, bromoacetyl, iodoacetyl, thiol, epoxy and other reactive or linking functional groups, as well as residual free radicals and radical cations, through which a protein coupling reaction may be accomplished. A surface functional group may also be incorporated as a functionalized co-monomer because the surface of the detection probe may contain a relatively high surface concentration of polar groups. In addition, although detection probes are often functionalized after synthesis, in certain cases, such as poly(thiophenol), the particles are capable of direct covalent linking with a protein without the need for further modification. For example, referring to FIG. 2, one embodiment of the present invention for covalently conjugating a particle-containing detection probe is illustrated. As shown, the first step of conjugation is activation of carboxylic groups on the probe surface using carbodiimide. In the second step, the activated carboxylic acid groups are reacted with an amino group of an antibody to form an amide bond. The activation and/or antibody coupling may occur in a buffer, such as phosphate-buffered saline (PBS) (e.g., pH of 7.2) or 2-(N-morpholino) ethane sulfonic acid (MES) (e.g., pH of 5.3). As shown, the resulting detection probes may then be blocked with ethanolamine, for instance, to block any remaining activated sites. Overall, this process forms a conjugated detection probe, where the antibody is covalently attached to the probe. Besides covalent bonding, other attachment techniques, such as physical adsorption, may also be utilized in the present invention.

Referring again to FIG. 1, the assay device 20 also contains a detection zone 31 within which is immobilized a capture reagent that is capable of binding to the conjugated detection probes. For example, in some embodiments, the capture reagent may be a biological capture reagent. Such biological capture reagents are well known in the art and may include, but are not limited to, antigens, haptens, protein A or G, neutravidin, avidin, streptavidin, captavidin, primary or secondary antibodies (e.g., polyclonal, monoclonal, etc.), and complexes thereof. The capture reagent serves as a stationary binding site for complexes formed between the analyte and conjugated detection probes. Upon reaching the detection zone 31, one of the binding sites of the analyte is occupied by the specific binding member of the conjugated probe. However, the free binding site of the analyte may bind to the immobilized capture reagent. Upon being bound to the immobilized capture reagent, the complexed probes form a new ternary sandwich complex.

The detection zone 31 may generally provide any number of distinct detection regions so that a user may better determine the concentration of a particular analyte within a test sample. Each region may contain the same capture reagents, or may contain different capture reagents for capturing multiple analytes. For example, the detection zone 31 may include two or more distinct detection regions (e.g., lines, dots, etc.). The detection regions may be disposed in the form of lines in a direction that is substantially perpendicular to the flow of the test sample through the assay device 20. Likewise, in some embodiments, the detection regions may be disposed in the form of lines in a direction that is substantially parallel to the flow of the test sample through the assay device.

Although the detection zone 31 may indicate the presence of an analyte, it is often difficult to accurately determine the relative concentration of the analyte within the test sample under actual test conditions. Thus, the assay device 20 may also include a calibration zone 32. In this embodiment, the calibration zone 32 is formed on the porous membrane 23 and is positioned downstream from the detection zone 31. The calibration zone 32 is provided with a capture reagent that is capable of binding to probes, whether uncaptured detection probes or separate calibration probes, which pass through the detection zone 31. Similar to the detection zone 31, the calibration zone 32 may also provide any number of distinct calibration regions in any direction so that a user may better determine the concentration of a particular analyte within a test sample.

Each region may contain the same capture reagents, or may contain different capture reagents for capturing different types of probes. The capture reagents utilized in the calibration zone 32 may be the same or different than the capture reagents used in the detection zone 31. In one embodiment, the capture reagent for the calibration zone 32 is a polyelectrolyte, such as described in U.S. Publication No. 2003/0124739 to Sono, et al., which is incorporated herein its entirety by reference thereto for all purposes. When utilized, the polyelectrolyte may have a net positive or negative charge, as well as a net charge that is generally neutral. For instance, some suitable examples of polyelectrolytes having a net positive charge include, but are not limited to, polylysine (commercially available from Sigma-Aldrich Chemical Co., Inc. of St. Louis, Mo.), polyethyleneimine; epichlorohydrin-functionalized polyamines and/or polyamidoamines, such as poly(dimethylamine-co-epichlorohydrin); polydiallyldimethylammonium chloride; cationic cellulose derivatives, such as cellulose copolymers or cellulose derivatives grafted with a quaternary ammonium water-soluble monomer; and so forth. In one particular embodiment, CelQuat® SC-230M or H-100 (available from National Starch & Chemical, Inc.), which are cellulosic derivatives containing a quaternary ammonium water-soluble monomer, may be utilized. Moreover, some suitable examples of polyelectrolytes having a net negative charge include, but are not limited to, polyacrylic acids, such as poly(ethylene-co-methacrylic acid, sodium salt), and so forth. It should also be understood that other polyelectrolytes may also be utilized, such as amphiphilic polyelectrolytes (i.e., having polar and non-polar portions). For instance, some examples of suitable amphiphilic polyelectrolytes include, but are not limited to, poly(styryl-b-N-methyl 2-vinyl pyridinium iodide) and poly(styryl-b-acrylic acid), both of which are available from Polymer Source, Inc. of Dorval, Canada.

Although any polyelectrolyte may generally be used, the polyelectrolyte selected for a particular application may vary depending on the nature of the detection probes, the porous membrane, and so forth. In particular, the distributed charge of a polyelectrolyte allows it to bind to substances having an

opposite charge. Thus, for example, polyelectrolytes having a net positive charge are often better equipped to bind with probes that are negatively charged, while polyelectrolytes that have a net negative charge are often better equipped to bind to probes that are positively charged. Thus, in such instances, the ionic interaction between these molecules allows the required binding to occur within the calibration zone **32**. Nevertheless, although ionic interaction is primarily utilized to achieve the desired binding in the calibration zone **32**, it has also been discovered that polyelectrolytes may bind with detection probes having a similar charge.

The calibration regions may be pre-loaded on the porous membrane **23** with different amounts of the capture reagent so that a different signal intensity is generated by each calibration region upon migration of the probes. The overall amount of capture reagent within each calibration region may be varied by utilizing calibration regions of different sizes and/or by varying the concentration or volume of the capture reagent in each calibration region. If desired, an excess of detection probes may be employed in the assay device **20** so that each calibration region reaches its full and predetermined potential for signal intensity. That is, the amount of uncaptured detection probes that are deposited upon calibration regions are predetermined because the amount of the capture reagent employed on the calibration regions is set at a predetermined and known level. In the alternative, a predetermined amount of separate calibration probes may be used that are configured to only bind to the capture reagent at the calibration zone **32**.

Referring to FIG. 3, one embodiment of a method for detecting the presence of an analyte will now be described in more detail. Initially, a test sample containing an analyte A is applied to the sampling pad **17**. At the sampling pad **17**, a certain quantity of the analyte A binds to a capture reagent **60** immobilized at the scavenging zone **35**, such as an amount less than or equal to a predefined base quantity of analyte considered "normal" for the particular test sample. From the sampling pad **17**, any analyte A in excess of the predefined base quantity travels in the direction "L" to the conjugate pad **22**, where it mixes with conjugated detection probes **41** and calibration probes **43** (may or may not be conjugated). In this embodiment, the excess analyte A binds with the conjugated detection probes **41** to form analyte/conjugated probe complexes **49**. Because the scavenging zone **35** is positioned upstream from the conjugate pad **22**, it is not necessary to supply detection probes **41** for binding to any of the analyte A that is already captured by the scavenging zone **35**. In this manner, the overall amount of required probes is reduced, which provides substantial cost savings.

At the detection zone **31**, the complexes **49** are captured by a capture reagent **90**. If desired, the capture reagent **60** at the scavenging zone **35** is identical to the capture reagent **90**. Thus, should any of the capture reagent **60** somehow become free from the scavenging zone **35** and travel to the detection zone **31**, it will not bind to the capture reagent **90** and adversely impact the desired reduction in detection sensitivity. Further, the calibration probes **43** travel through the detection zone **31** to bind with a capture reagent (not shown) at the calibration zone **32**.

Once captured, the signal of the probes at the detection zone **31** and calibration zone **32** may be measured using any known method of detection, such as visually or with a reading device. Regardless of the technique utilized, the quantity of the analyte in excess of the predefined base quantity may be ascertained by correlating the emitted signal, I_s , of the probes captured at the detection zone **31** to a predetermined analyte concentration. In some embodiments, the intensity signal, I_s , may also be compared with the emitted signal, I_c , of probes

captured at the calibration zone **32**. The total amount of the probes at the calibration zone **32** is predetermined and known and thus may be used for calibration purposes. For example, in some embodiments (e.g., sandwich assays), the quantity of analyte in excess of the predefined base quantity is directly proportional to the ratio of I_s to I_c . In other embodiments (e.g., competitive assays), the quantity of analyte in excess of the predefined base quantity is inversely proportional to the ratio of I_s to I_c . Based upon the intensity range in which the detection zone **31** falls, the general concentration range for the analyte may be determined. As a result, calibration and sample testing may be conducted under approximately the same conditions at the same time, thus providing reliable quantitative or semi-quantitative results, with increased sensitivity.

If desired, the ratio of I_s to I_c may be plotted versus the analyte concentration for a range of known analyte concentrations to generate a calibration curve. To determine the quantity of analyte in an unknown test sample that is in excess of a predefined base quantity, the signal ratio may then be converted to analyte concentration according to the calibration curve. It should be noted that alternative mathematical relationships between I_s and I_c may be plotted versus the analyte concentration to generate the calibration curve. For example, in one embodiment, the value of $I_s/(I_s+I_c)$ may be plotted versus analyte concentration to generate the calibration curve.

Although various embodiments of device configurations have been described above, it should be understood, that a device of the present invention may generally have any configuration desired, and need not contain all of the components described above. Various other device configurations, for instance, are described in U.S. Pat. No. 5,395,754 to Lambotte, et al.; U.S. Pat. No. 5,670,381 to Jou, et al.; and U.S. Pat. No. 6,194,220 to Malick, et al., which are incorporated herein in their entirety by reference thereto for all purposes.

Various assay formats may also be used to test for the presence or absence of an analyte using the assay device of the present invention. For instance, in the embodiment described above, a "sandwich" format is utilized. Other examples of such sandwich-type assays are described in. by U.S. Pat. No. 4,168,146 to Grubb, et al. and U.S. Pat. No. 4,366,241 to Tom, et al., which are incorporated herein in their entirety by reference thereto. An alternative technique is the "competitive-type" assay. In a "competitive-type" assay, the detection probe is typically a labeled analyte or analyte-analog that competes for binding of an antibody with any unlabeled analyte present in the sample. Competitive assays are sometimes used for detection of hapten analytes, each hapten being monovalent and capable of binding only one antibody molecule. Examples of competitive immunoassay devices are described in U.S. Pat. No. 4,235,601 to Deutsch, et al., U.S. Pat. No. 4,442,204 to Liotta, and U.S. Pat. No. 5,208,535 to Buechler, et al., which are incorporated herein in their entirety by reference thereto for all purposes.

The present inventor has discovered that a scavenging zone may be utilized to reduce the sensitivity of an assay device by capturing a quantity of an analyte within a test sample that is less than or equal to a predefined base quantity, such as a quantity that is considered "normal" for a particular test sample. In this manner, the analyte captured at the scavenging zone is not detected. Desirably, the test sample contacts the scavenging zone before mixing with detection probes minimize the required amount of detection probes and achieve substantial cost savings.

The present invention may be better understood with reference to the following examples.

Example 1

The ability to form a lateral flow assay device according to the present invention was demonstrated. A nitrocellulose porous membrane (HF 120 from Millipore, Inc.) having a length of approximately 30 centimeters was laminated onto supporting cards. Goldline™ (a polylysine solution obtained from British Biocell International) was stripped onto the membrane to form a calibration line. In addition, monoclonal antibody for C-reactive protein (Mab2) (A#5804, available from BiosPacific, concentration of 1 milligram per milliliter) was immobilized on the porous membrane to form a detection line. The membrane samples were then dried for 1 hour at a temperature of 37° C. A cellulosic fiber wicking pad (Millipore, Inc. Co.) was attached to one end of the membrane. 120 microliters of gold particles conjugated with C-reactive protein (Mab1) (A#5811, available from BiosPacific, Inc.) was mixed with 250 microliters of sucrose in 630 microliters of water. The suspension was then loaded onto a 20-centimeter long glass fiber conjugate pad (Millipore Co.). The glass fiber pad was then dried at 37° C. overnight and laminated to the supporting card. The nitrocellulose membrane was attached to one end of the conjugate pad, while a sample pad was attached to the other end.

Various types of sample pads were evaluated. Specifically, the sample pads tested were a nylon membrane available from Millipore, a nitrocellulose membrane available from Schleicher & Schuell, and a nitrocellulose membrane available from Millipore. A scavenging antibody, i.e., monoclonal antibody for C-reactive protein (Mab2) (A#5804, available from BiosPacific Inc.), was applied to the sampling pads at various concentrations to form a scavenging zone. Specifically, the scavenging antibody was applied to the nylon membrane at concentrations of 0 and 0.5 milligrams per milliliter, to the Schleicher & Schuell membranes at a concentration of 0.5 milligrams per milliliter, and to the Millipore membrane at a concentration of 2.36 milligrams per milliliter. Each membrane was then dried at 37° C., cut into 4-millimeter strips, and put onto the conjugate pad to complete the assembly of a 4-millimeter full strip.

80 microliters of a C-reactive protein solution (170 nanograms per milliliter) was applied to each sampling pad. Each assay was visually observed for the detection signal intensity. For the nylon membrane sample pad, the detection signal intensity was the same for scavenging antibody concentrations of 0 and 0.5 milligrams per milliliter. For the Schleicher & Schuell nitrocellulose membrane, the detection signal was detected, but its intensity was reduced. For the Millipore nitrocellulose sample pad, the detection line gave no signal.

Example 2

A lateral flow assay device was formed as described above in Example 1, except that the sample pad was made from a membrane containing ultra-high molecular weight polyethylene spherical particles, which was obtained from the Porex Corporation of Fairburn, Ga. under the name "Lateral-Flo" membrane. In addition, the concentration of the scavenging antibody was 1 milligram per milliliter. To this sample pad, a solution containing 40 microliters of 2% Tween 20 and 40 microliters of C-reactive protein was applied. The C-reactive protein concentrations tested were 0, 50 and 500 nanograms per milliliter. Comparative samples were also tested that did not contain the scavenging antibody. The assay was allowed

to develop for approximately 10 minutes, and the detection line intensity was then read using a reflectance reader.

For the samples containing the scavenging antibody, the detection line was negative for C-reactive protein concentrations of 0 and 50 nanograms per milliliter. For the comparative sample, a C-reactive protein concentration of 50 nanograms per milliliter resulted in a strong positive signal for the detection line. The results are shown in FIG. 4.

Example 3

A lateral flow assay device was formed as described above in Example 1, except that the scavenging antibody was monoclonal antibody for C-reactive protein (Mab1) (A#5811, available from BiosPacific) at a concentration of 5.7 milligrams per milliliter. To the sampling pad, 1 microliter of various C-reactive protein solutions (CRP concentrations of 1000, 10000 and 50000 nanograms per milliliter) were applied and run with 150 microliters of diluent (Tween:PBS 10:6). The assay was allowed to develop for approximately 10 minutes. The detection signal intensity was visually observed. The device gave a positive result for a C-reactive protein concentration of 50 nanograms per milliliter, but a negative for C-reactive protein concentrations of 1 and 10 nanograms per milliliter.

While the invention has been described in detail with respect to the specific embodiments thereof, it will be appreciated that those skilled in the art, upon attaining an understanding of the foregoing, may readily conceive of alterations to, variations of, and equivalents to these embodiments. Accordingly, the scope of the present invention should be assessed as that of the appended claims and any equivalents thereto.

What is claimed is:

1. A method for detecting an analyte in a test sample, the method comprising:

i) providing an assay device that comprises:

- a sampling pad that defines a scavenging zone in which is non-diffusively immobilized a first capture reagent configured to specifically bind with the analyte;
- a conjugate pad that contains detection probes and optional calibration probes, the detection probes being conjugated with a first binding member configured to specifically bind with the analyte; and
- a porous membrane in fluid communication with the sampling pad and the conjugate pad, the porous membrane defining a detection zone in which is immobilized a second capture reagent configured to specifically bind with the analyte and a calibration zone within which is immobilized a third capture reagent including a polyelectrolyte having a net charge opposite to that of and configured to bind with the detection probes, the calibration probes, or combinations thereof,

wherein the detection zone and the calibration zone are located downstream from the sampling pad and the conjugate pad;

ii) contacting the assay device with the test sample, wherein a quantity of the analyte in the test sample less than or equal to a predefined base quantity binds to the first capture reagent at the scavenging zone and a quantity of the analyte in excess of the predefined base quantity binds to the specific binding member of the detection probes to form complexes that flow through the porous membrane and bind to the second capture reagent in the detection zone to generate a detection signal, and wherein the detection probes, the calibration probes, or

13

- a combination thereof, flow through the porous membrane and bind to the third capture reagent at the calibration zone to generate a calibration signal;
- iii) detecting the intensity of the detection signal and the calibration signal; and
- iv) comparing the intensity of the detection signal to the intensity of the calibration signal, wherein the quantity of the analyte within the test sample in excess of the predefined base quantity is proportional to the intensity of the detection signal calibrated by the intensity of the calibration signal.
2. A method as defined in claim 1, wherein said first capture reagent at said scavenging zone is selected from the group consisting of antigens, haptens, protein A or G, neutravidin, avidin, streptavidin, captavidin, antibodies, and complexes thereof.
3. A method as defined in claim 1, wherein said second capture reagent at said detection zone is selected from the group consisting of antigens, haptens, protein A or G, neutravidin, avidin, streptavidin, captavidin, antibodies, and complexes thereof.
4. A method as defined in claim 1, wherein said capture reagents at said scavenging zone and said detection zone are substantially identical.
5. A method as defined in claim 1, wherein said detection probes comprise a substance selected from the group consisting of chromogens, catalysts, luminescent compounds, radioactive compounds, direct visual labels, liposomes, and combinations thereof.
6. A method as defined in claim 1, wherein the conjugate pad is located downstream from the sampling pad.
7. A method as defined in claim 1, wherein the analyte includes an antigen.

14

8. A method as defined in claim 7, wherein the specific binding member of the detection probes includes an antibody.
9. A method as defined in claim 8, wherein the first capture reagent and the second capture reagent include antibodies that bind to the same epitope of the analyte.
10. A method as defined in claim 7, wherein the antigen includes C-reactive protein.
11. A method as defined in claim 1, wherein the test sample is blood or derived from blood.
12. A method as defined in claim 11, wherein the analyte includes C-reactive protein.
13. A method as defined in claim 12, wherein the predefined base quantity is about 10 micrograms of C-reactive protein per milliliter of the test sample.
14. A method as defined in claim 1, wherein the assay device further comprises a wicking pad in fluid communication with the porous membrane and located downstream from the detection zone and the calibration zone.
15. A method as defined in claim 1, wherein said polyelectrolyte has a net positive charge.
16. A method as defined in claim 15, wherein said polyelectrolyte is selected from the group consisting of polylysine, polyethyleneimine, epichlorohydrin-functionalized polyamines or polyamidoamines, polydiallyldimethyl-ammonium chloride, cationic cellulose derivatives, and combinations thereof.
17. A method as defined in claim 1, wherein said polyelectrolyte has a net negative charge.
18. A method as defined in claim 1, wherein the detection probes comprise latex microparticles.

* * * * *

专利名称(译)	降低测定装置灵敏度的方法		
公开(公告)号	US7713748	公开(公告)日	2010-05-11
申请号	US10/718996	申请日	2003-11-21
[标]申请(专利权)人(译)	金伯利-克拉克环球有限公司		
申请(专利权)人(译)	金佰利WORLDWIDE, INC.		
当前申请(专利权)人(译)	金佰利WORLDWIDE, INC.		
[标]发明人	WEI NING		
发明人	WEI, NING		
IPC分类号	G01N21/00 C12M1/34 G01N21/77 G01N33/53 G01N33/544 G01N33/566 G01N33/543 G01N31/22 G01N21/76 C12M3/00 C12Q1/00 G01N15/06 G01N33/558		
CPC分类号	G01N33/558 Y10S436/807		
其他公开文献	US20100081146A1		
外部链接	Espacenet USPTO		

摘要(译)

提供了一种用于检测驻留在测试样品中的分析物的存在或量的流通测定装置。该装置利用清除区，其含有用于目标分析物的捕获试剂。捕获试剂可以捕获小于或等于分析物的预定基础量的分析物的量，例如对于特定测试样品被认为是“正常”的量。因此，捕获试剂能够防止检测到一些分析物。以这种方式，可以以简单，廉价但有效的方式降低测定装置的灵敏度。

