



US 20070264675A1

(19) **United States**

(12) **Patent Application Publication**  
**Toner et al.**

(10) **Pub. No.: US 2007/0264675 A1**

(43) **Pub. Date: Nov. 15, 2007**

(54) **MICROFLUIDIC DEVICE FOR CELL SEPARATION AND USES THEREOF**

**Publication Classification**

(75) Inventors: **Mehmet Toner**, Wellesley, MA (US);  
**George Truskey**, Durham, NC (US);  
**Ravi Kapur**, Sharon, MA (US)

(51) **Int. Cl.**  
**C12Q 1/02** (2006.01)  
**G01N 33/53** (2006.01)  
(52) **U.S. Cl.** ..... **435/7.23**; 435/29; 435/7.1;  
435/7.21

Correspondence Address:  
**CLARK & ELBING LLP**  
**101 FEDERAL STREET**  
**BOSTON, MA 02110 (US)**

(57) **ABSTRACT**

(73) Assignee: **The General Hospital Corporation**,  
Boston, MA

The invention features methods for separating cells from a sample (e.g., separating fetal red blood cells from maternal blood). The method begins with the introduction of a sample including cells into one or more microfluidic channels. In one embodiment, the device includes at least two processing steps. For example, a mixture of cells is introduced into a microfluidic channel that selectively allows the passage of a desired type of cell, and the population of cells enriched in the desired type is then introduced into a second microfluidic channel that allows the passage of the desired cell to produce a population of cells further enriched in the desired type. The selection of cells is based on a property of the cells in the mixture, for example, size, shape, deformability, surface characteristics (e.g., cell surface receptors or antigens and membrane permeability), or intracellular properties (e.g., expression of a particular enzyme).

(21) Appl. No.: **11/800,940**

(22) Filed: **May 8, 2007**

**Related U.S. Application Data**

(63) Continuation of application No. 10/529,453, filed on Dec. 19, 2005, filed as 371 of international application No. PCT/US03/30965, filed on Sep. 29, 2003.

(60) Provisional application No. 60/414,065, filed on Sep. 27, 2002. Provisional application No. 60/414,258, filed on Sep. 27, 2002. Provisional application No. 60/414,102, filed on Sep. 27, 2002.

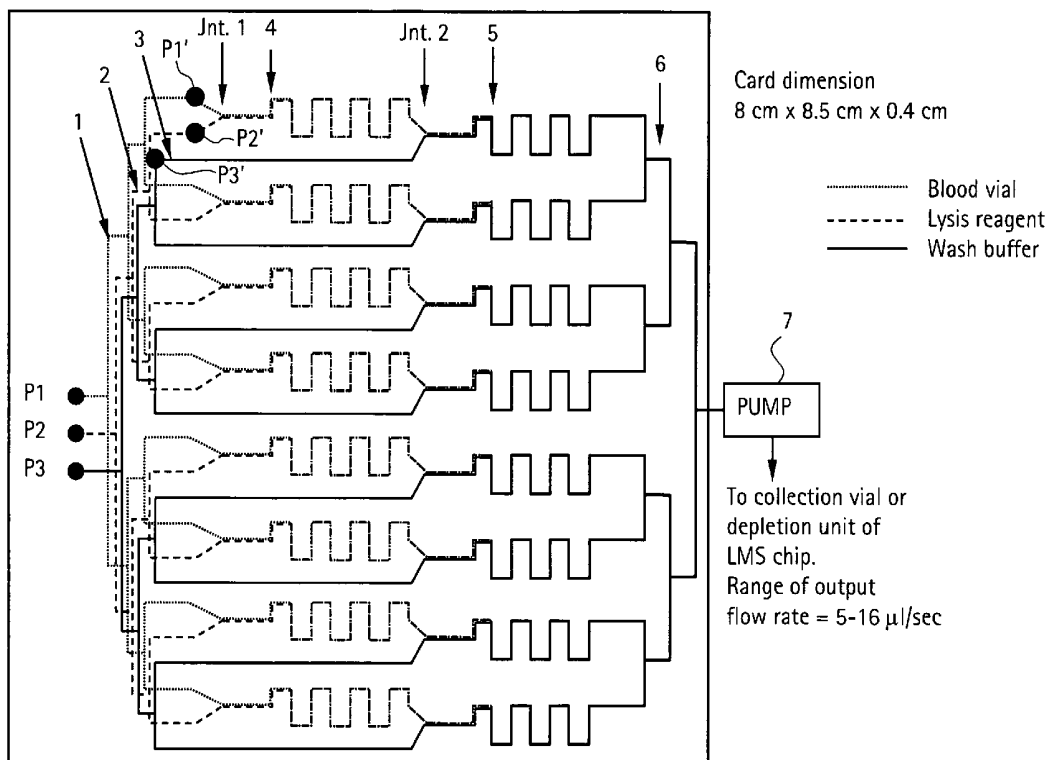

FIG. 1

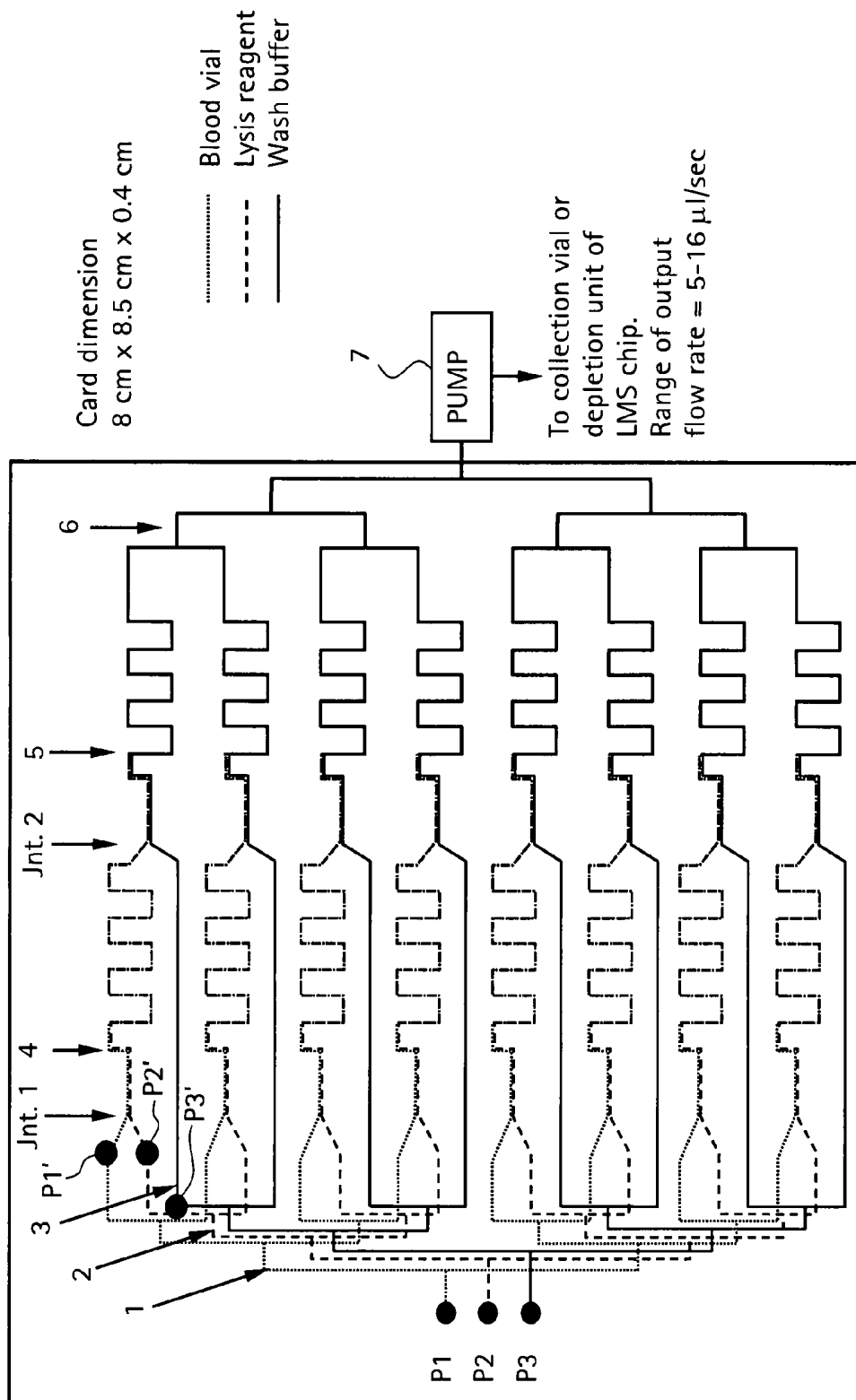
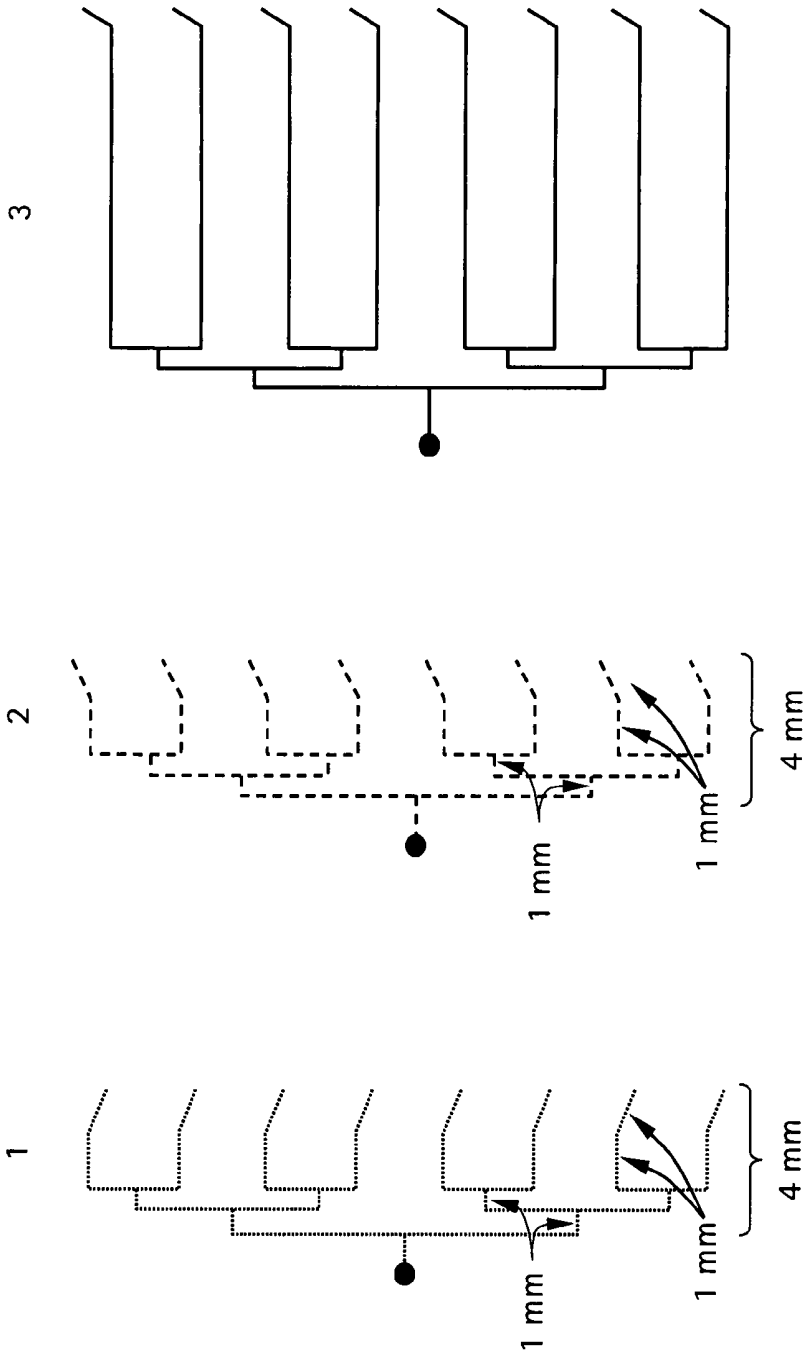

FIG. 2



Channel width = 100 microns, Channel depth = 100 microns

FIG. 3

One embodiment of dilution/reaction chambers

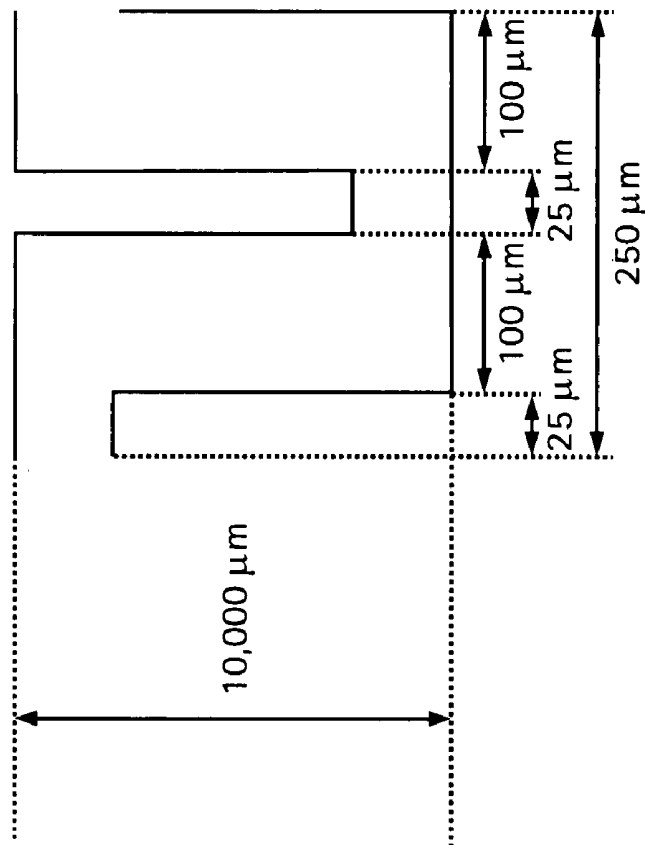

Unit Effective length = 20,050  $\mu\text{m}$

Unit Linear length = 250  $\mu\text{m}$

Unit Fluid volume = 0.2005  $\mu\text{l}$  ( $0.1 \times 0.1 \times 20.05$ )

# of Units in 33 mm linear length = 132

Total chamber volume = 26.46  $\mu\text{l}$  ( $0.2005 \times 132$ )

Fluid Residence Time = 42 seconds @ output flow rate of 5  $\mu\text{l}/\text{sec}$  for 8 networks operating in parallel

FIG. 4

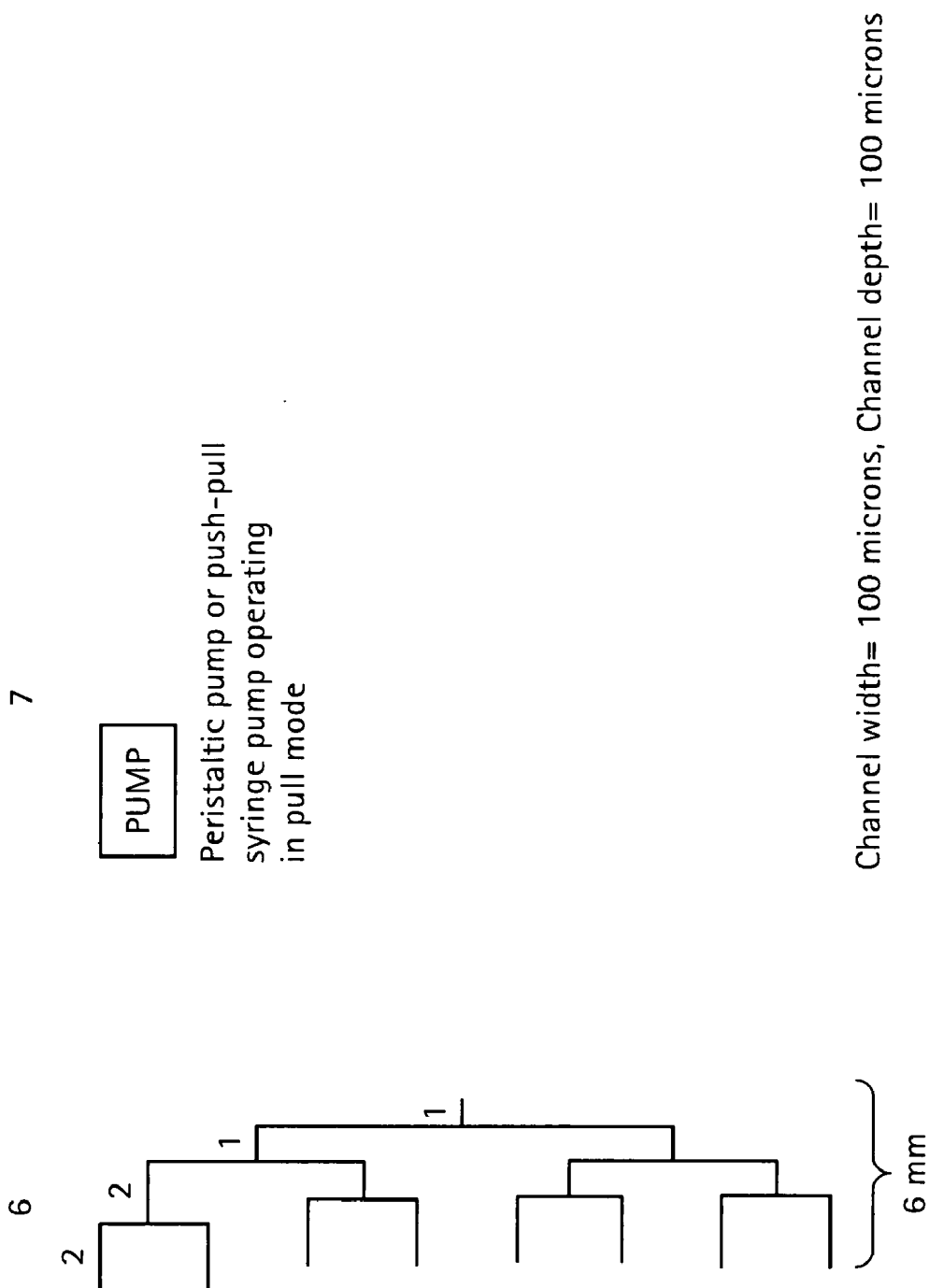
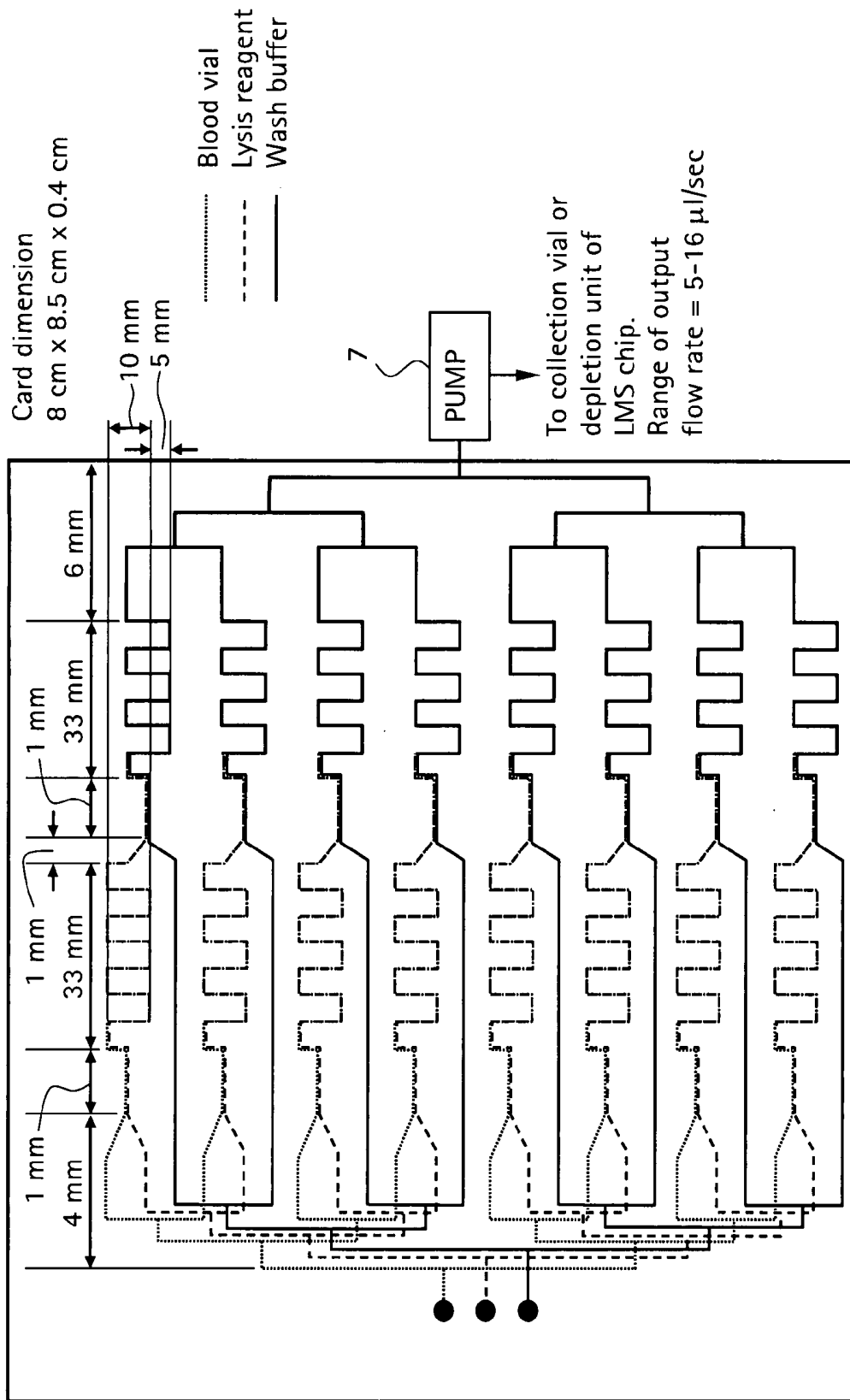
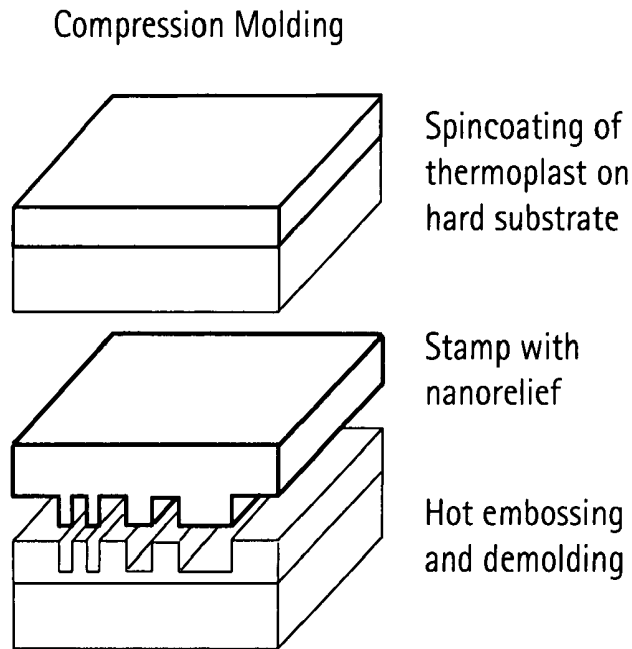

FIG. 5



# FIG. 6A



# FIG. 6B

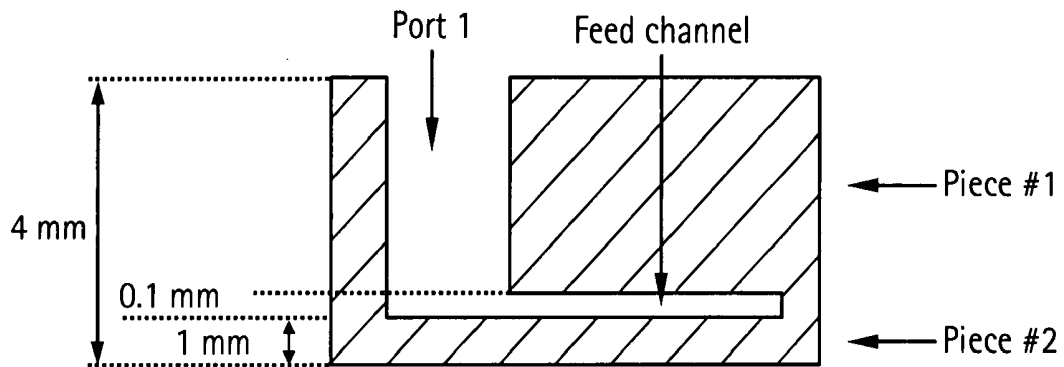

FIG. 7

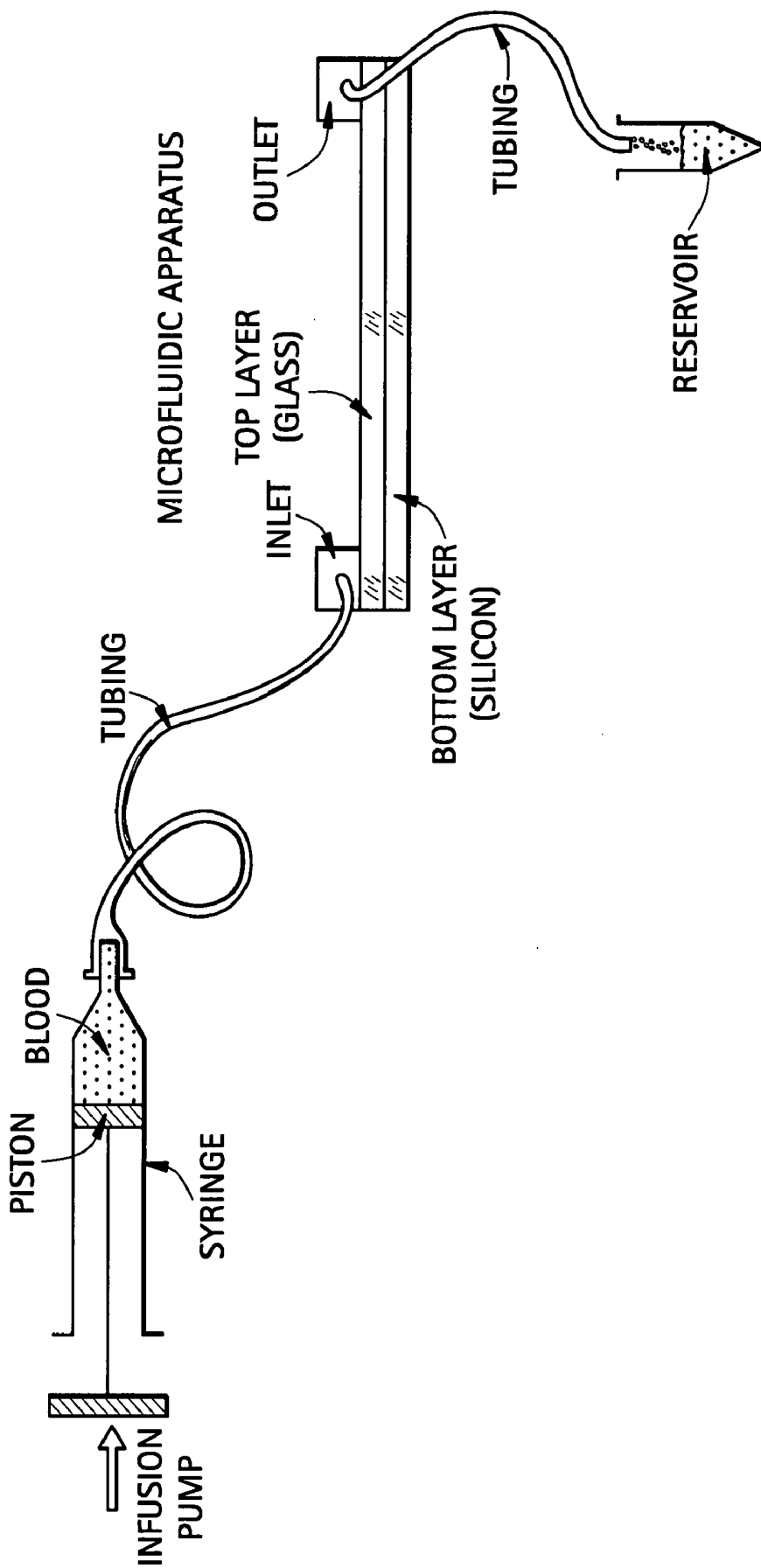



FIG. 8

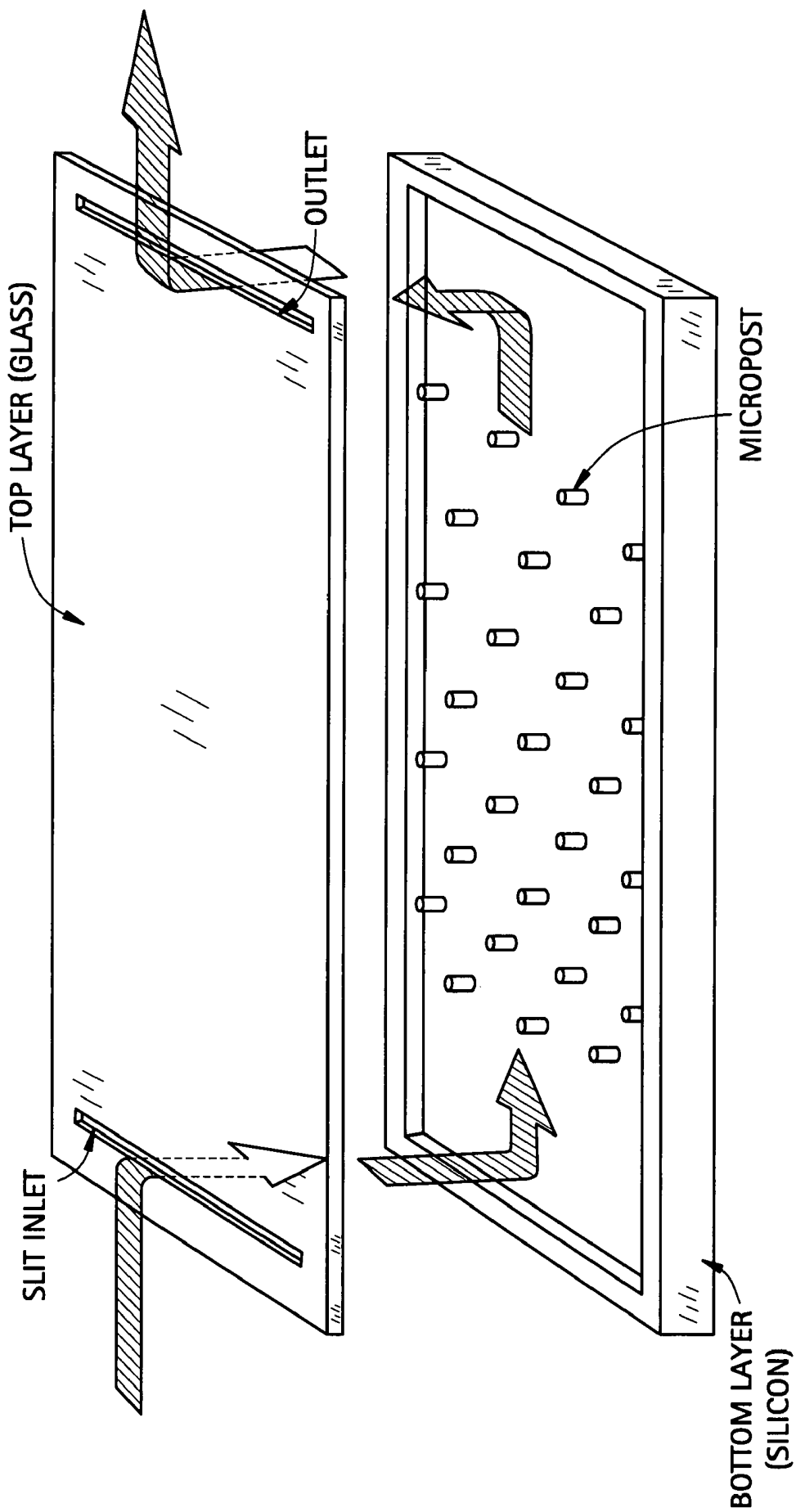

FIG. 9

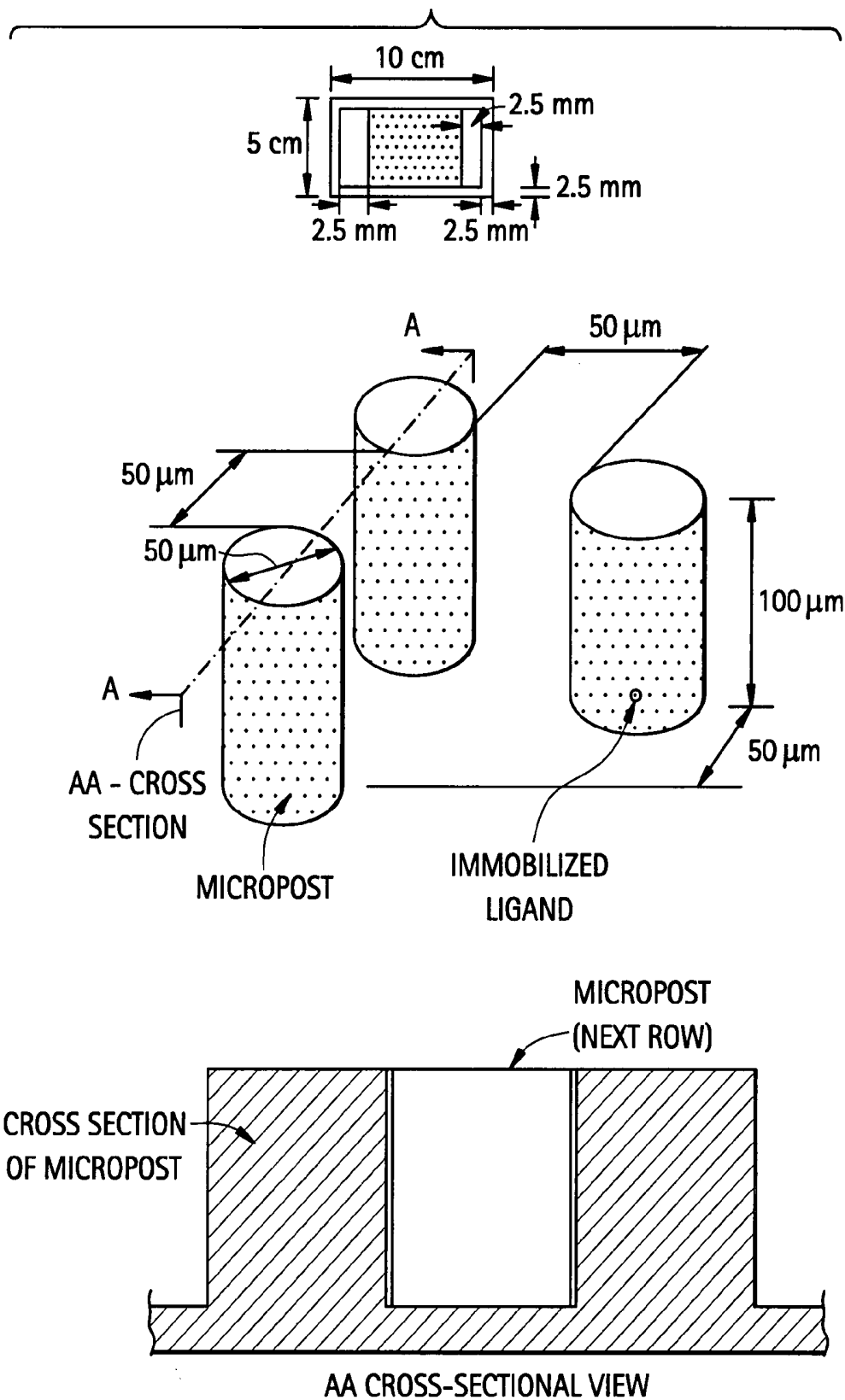

FIG. 10

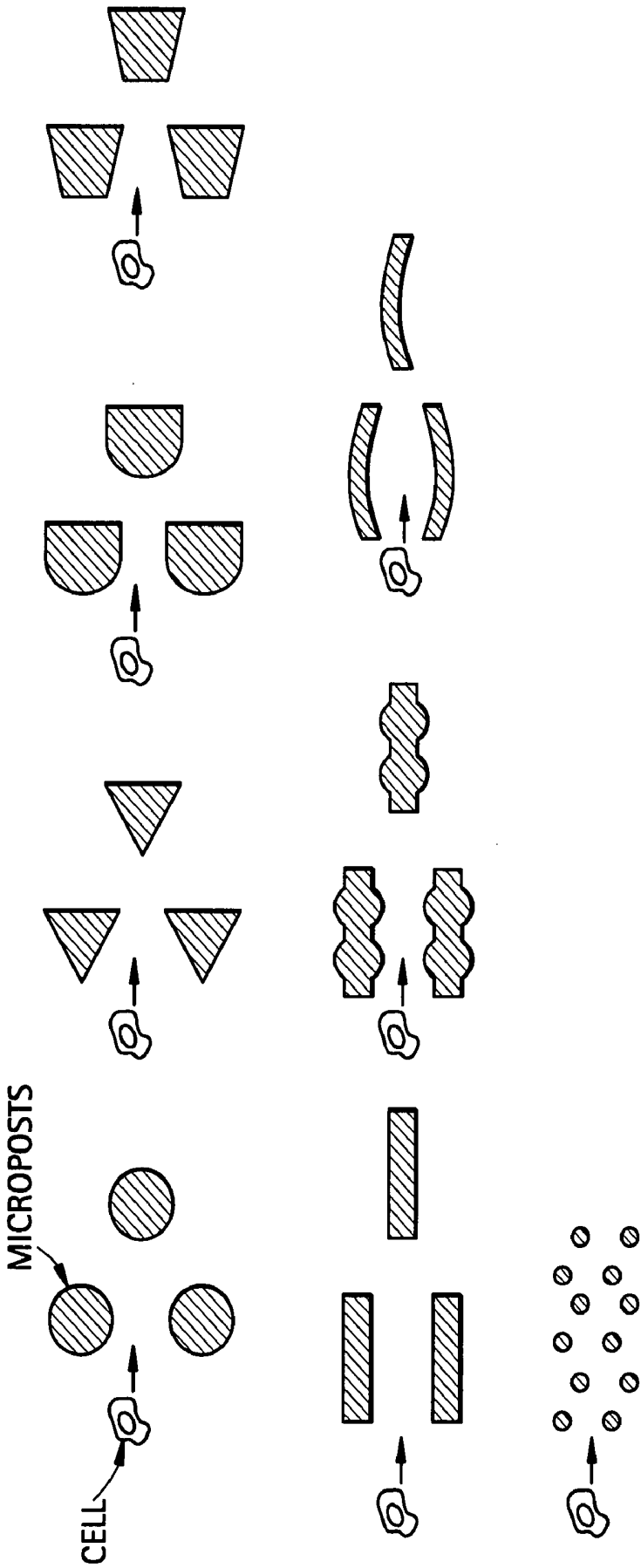

FIG. 11A

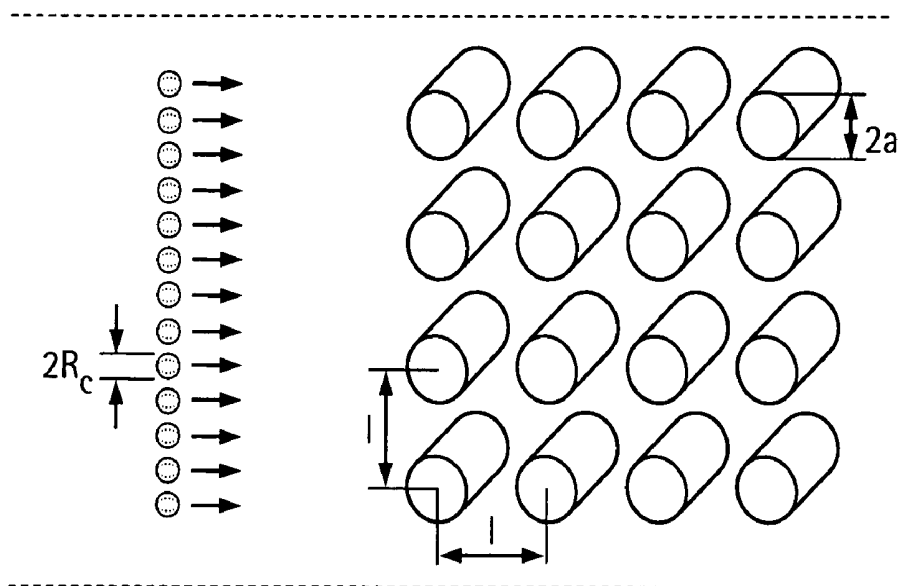

FIG. 11B

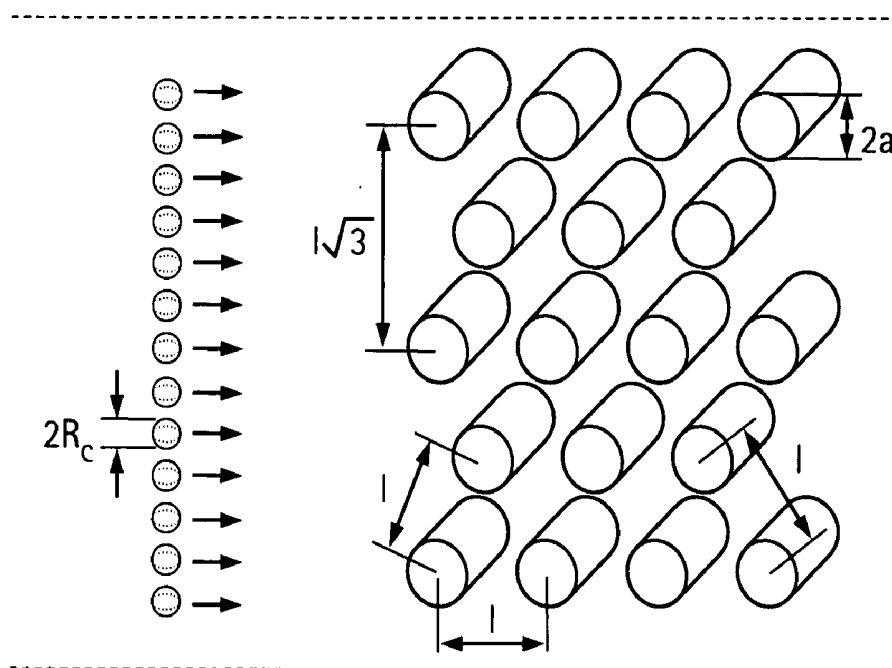

FIG. 12A

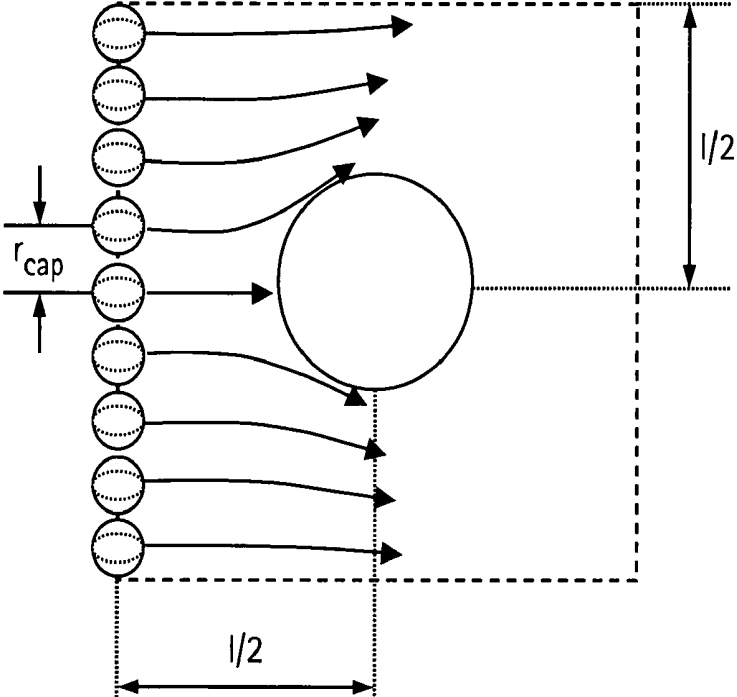

FIG. 12B

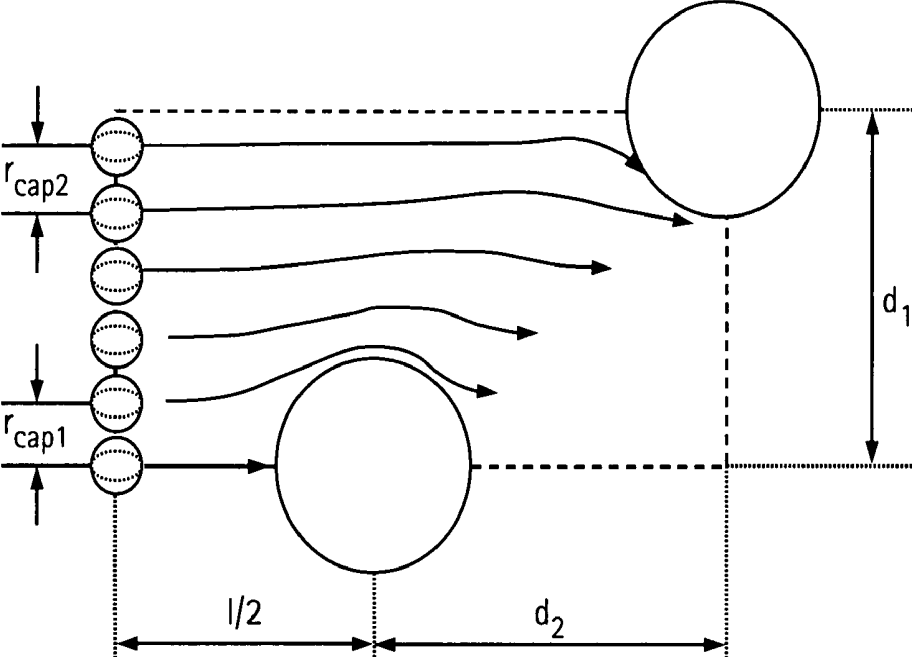

FIG. 13A

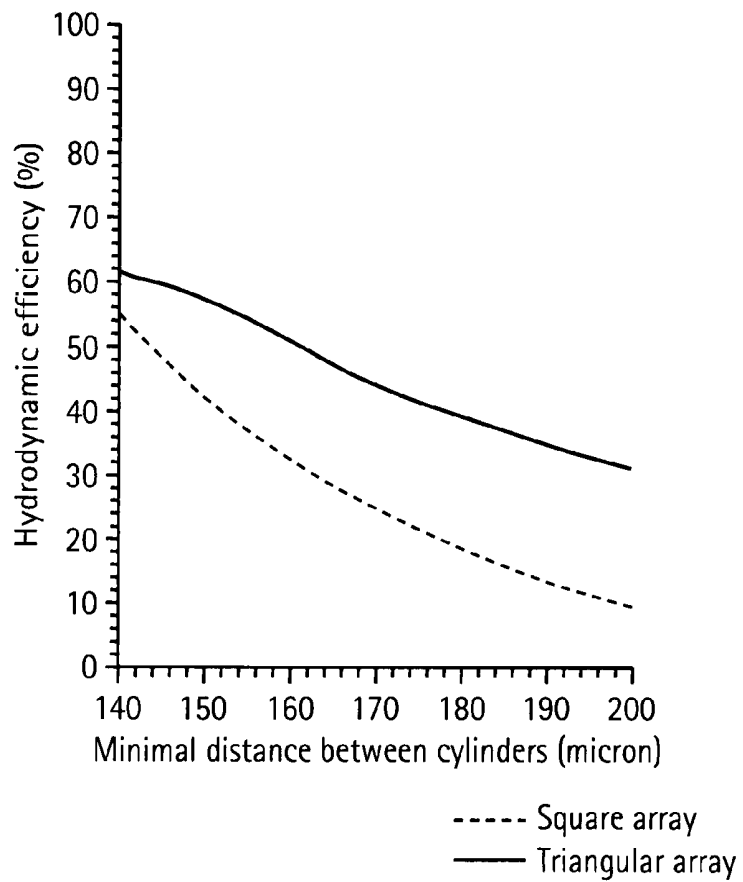

FIG. 13B

Adhesion  
is included

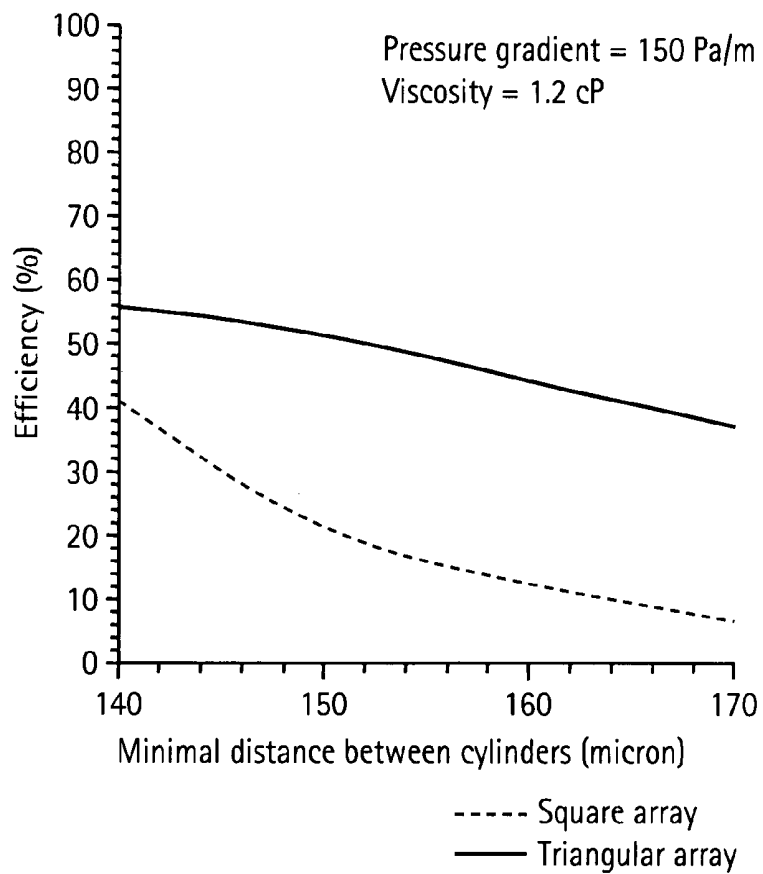

FIG. 14A

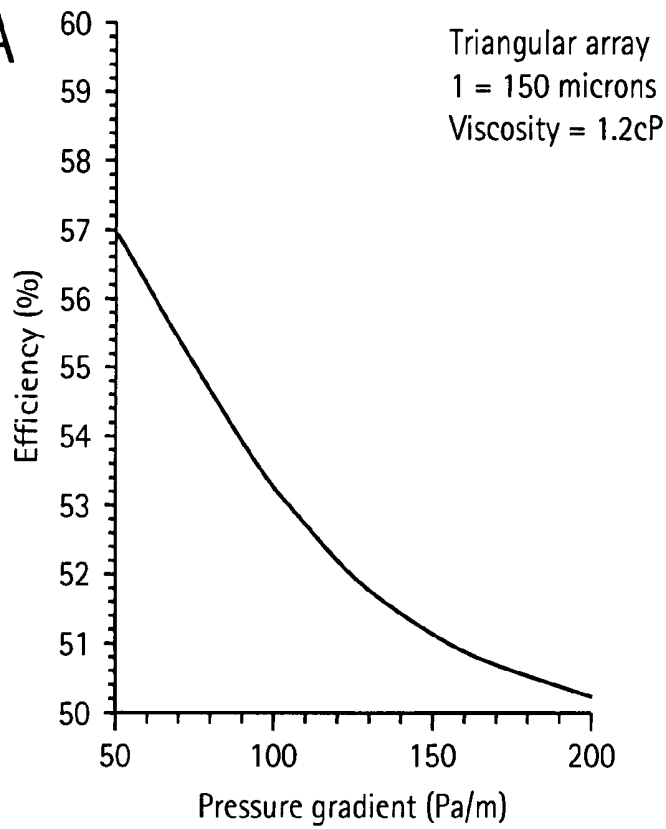

FIG. 14B

Adhesion  
is included

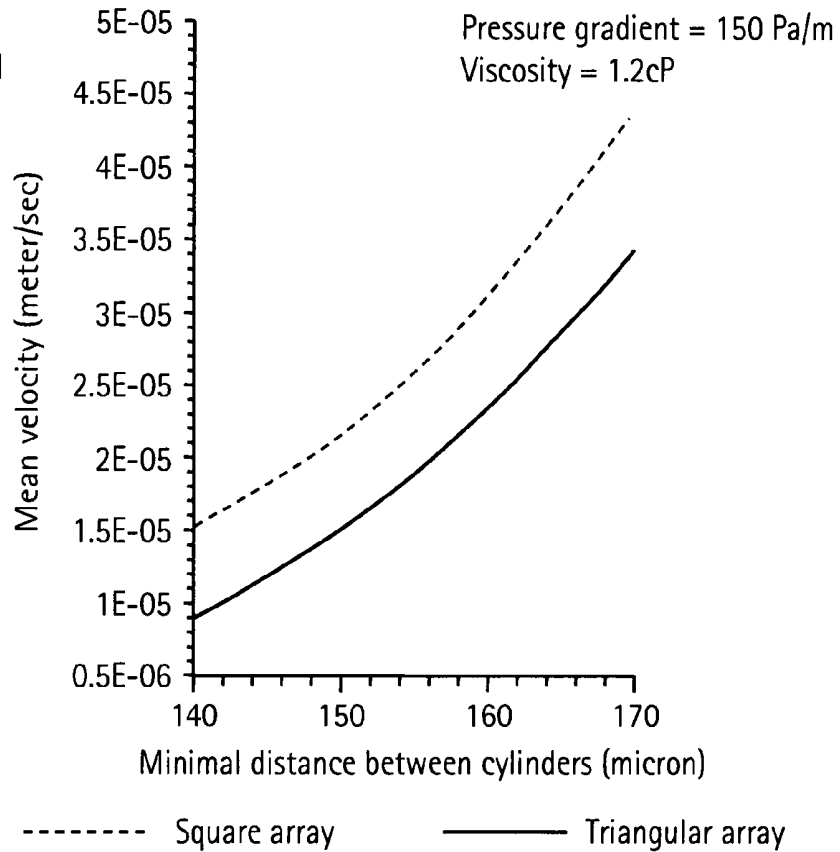

FIG. 15

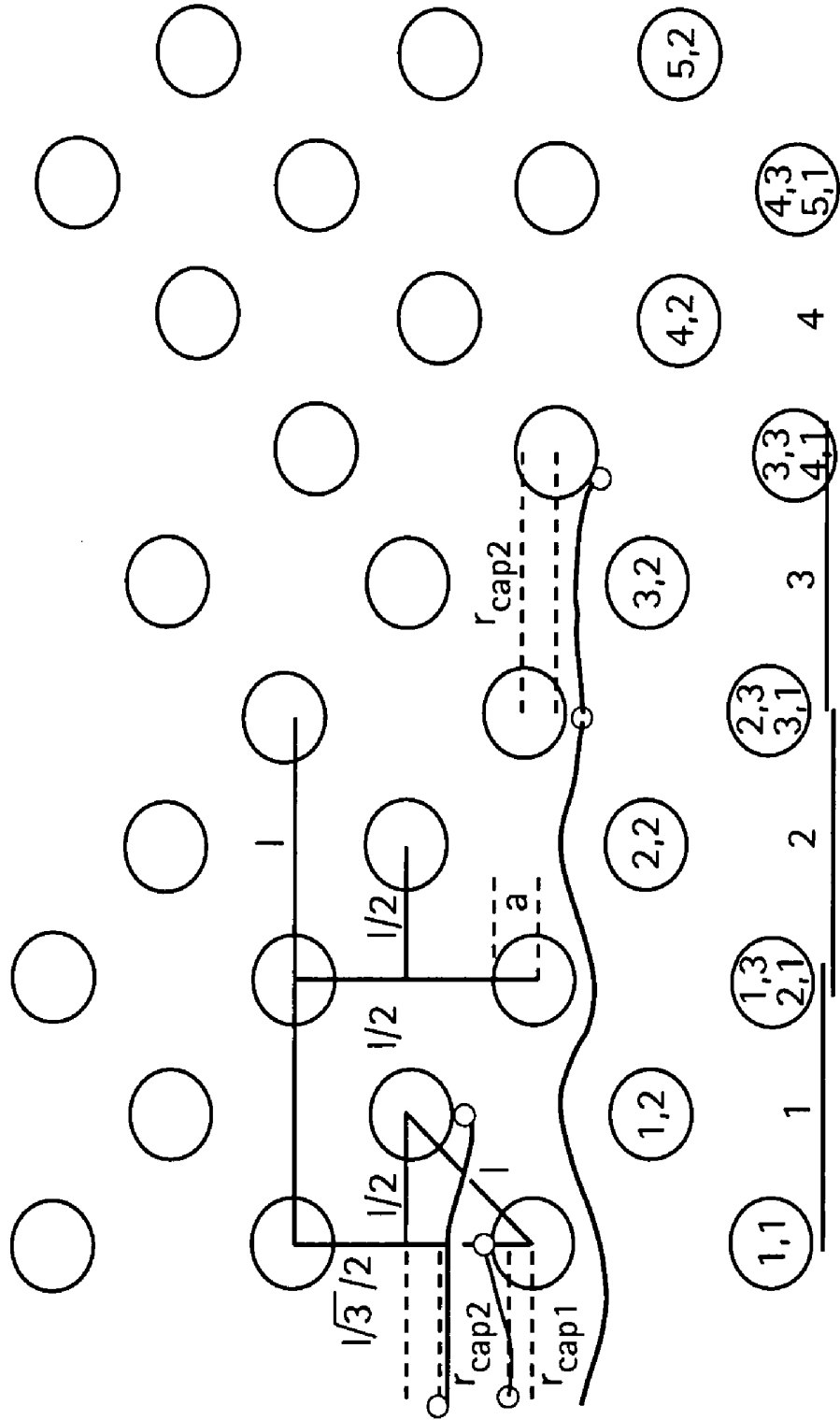



FIG. 16A

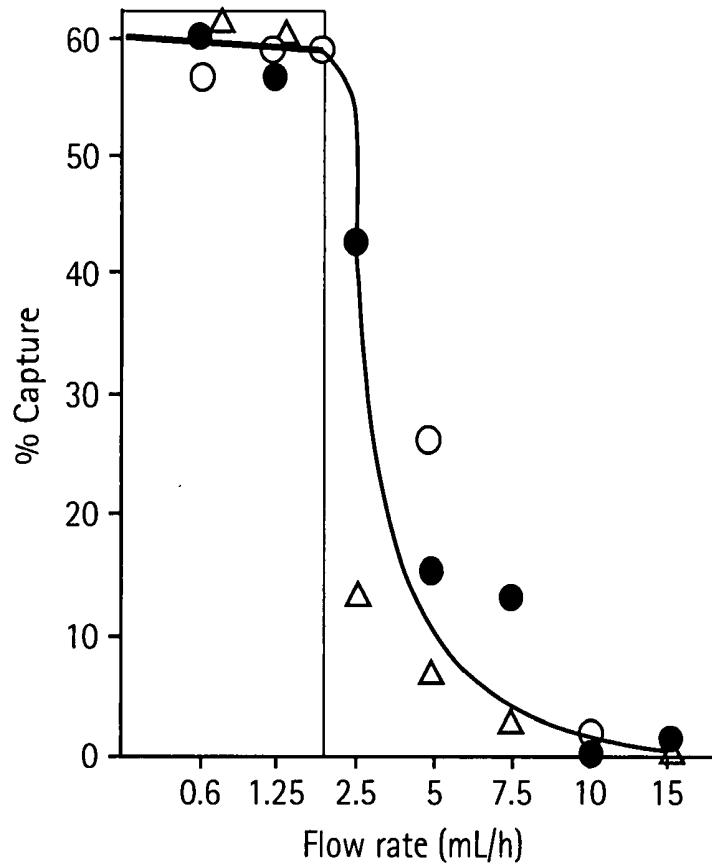

FIG. 16B

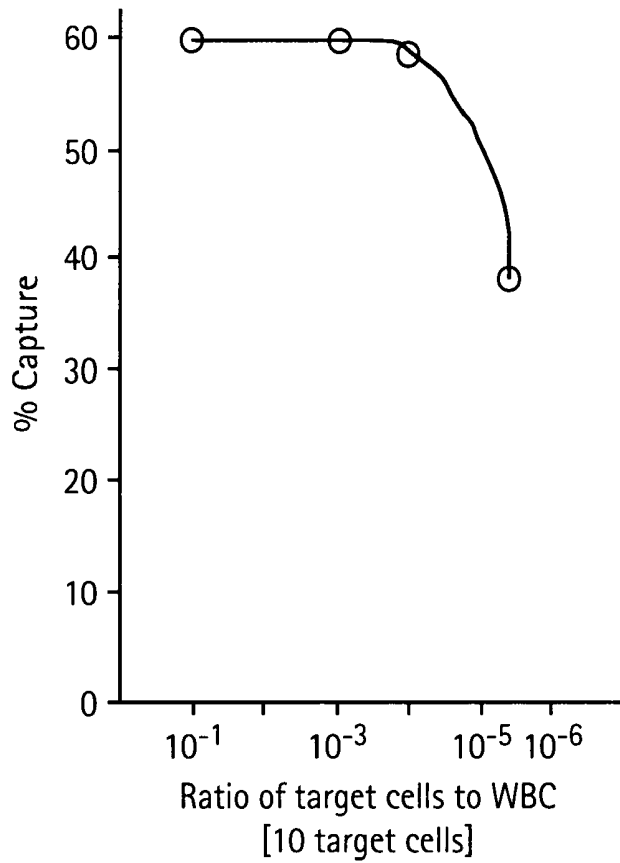
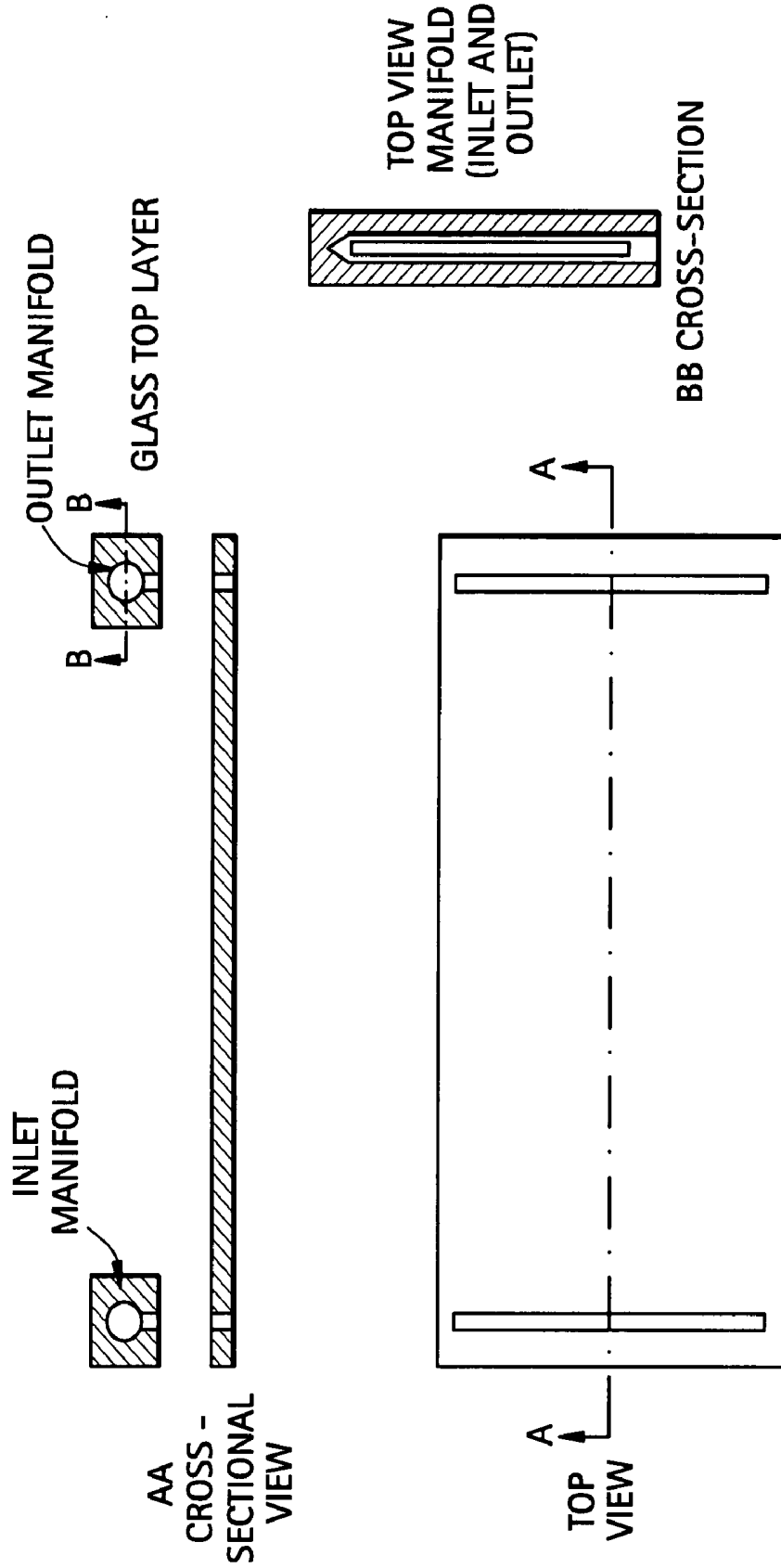

FIG. 17



# FIG. 18

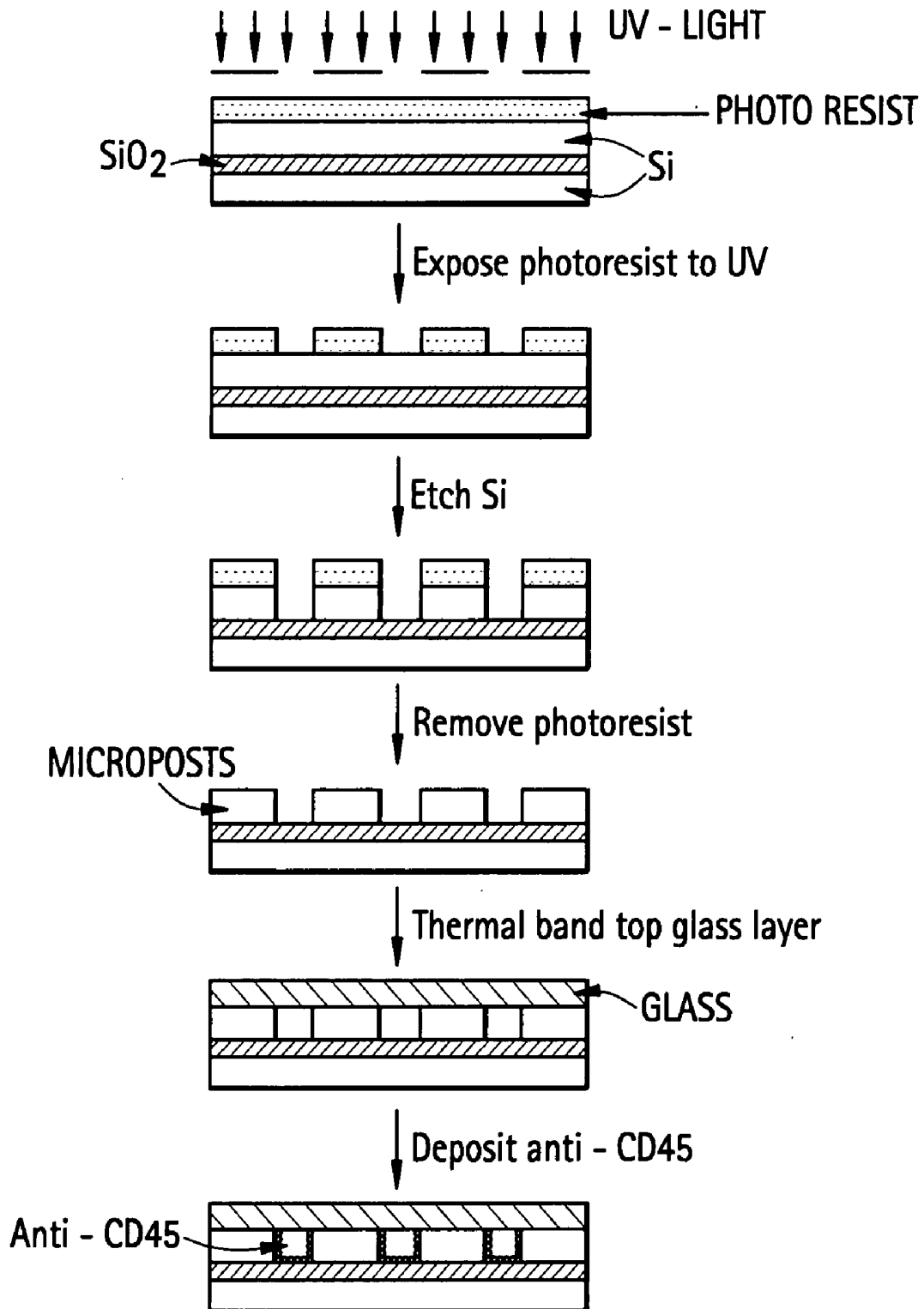

FIG. 19

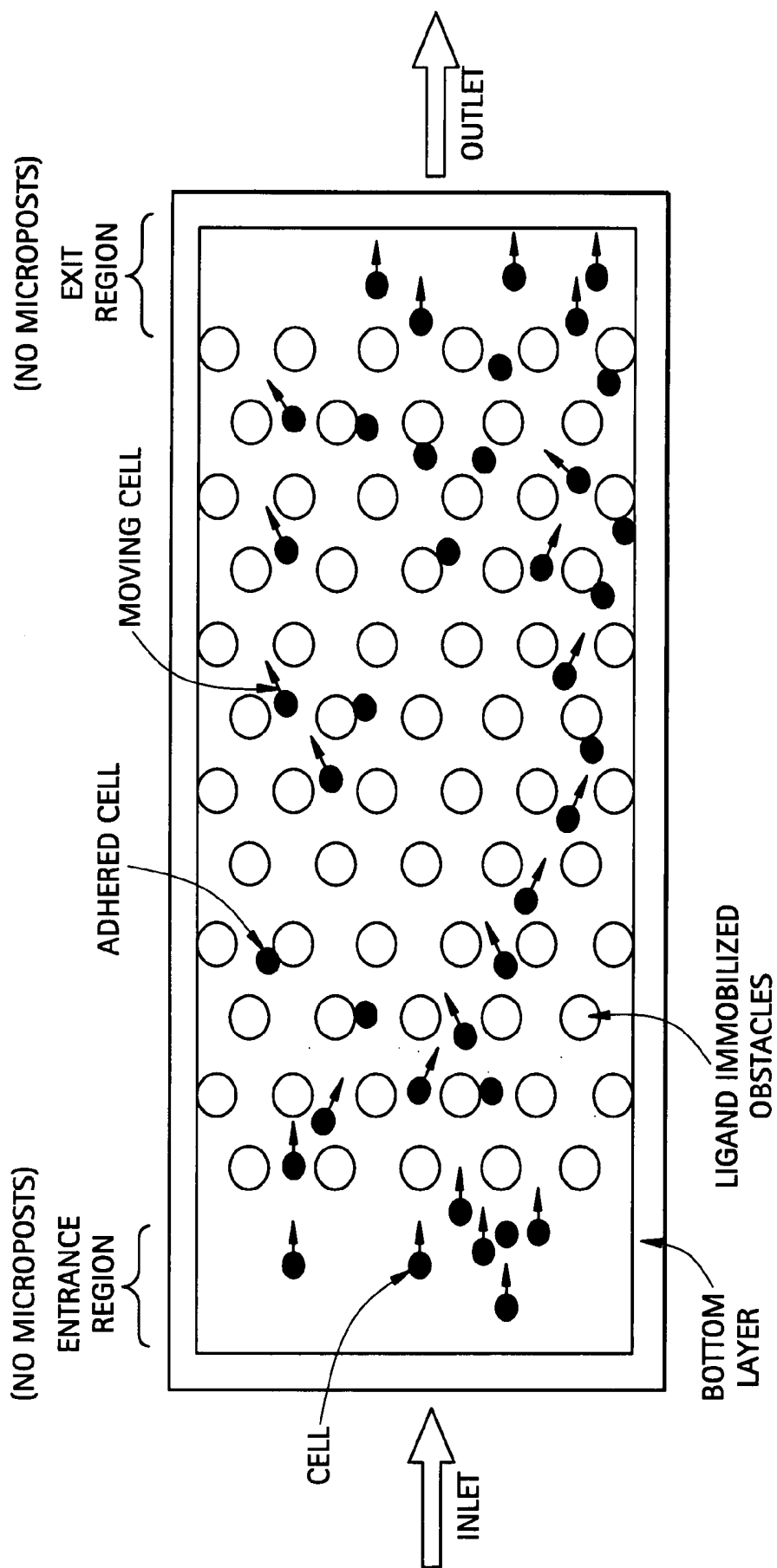

FIG. 20

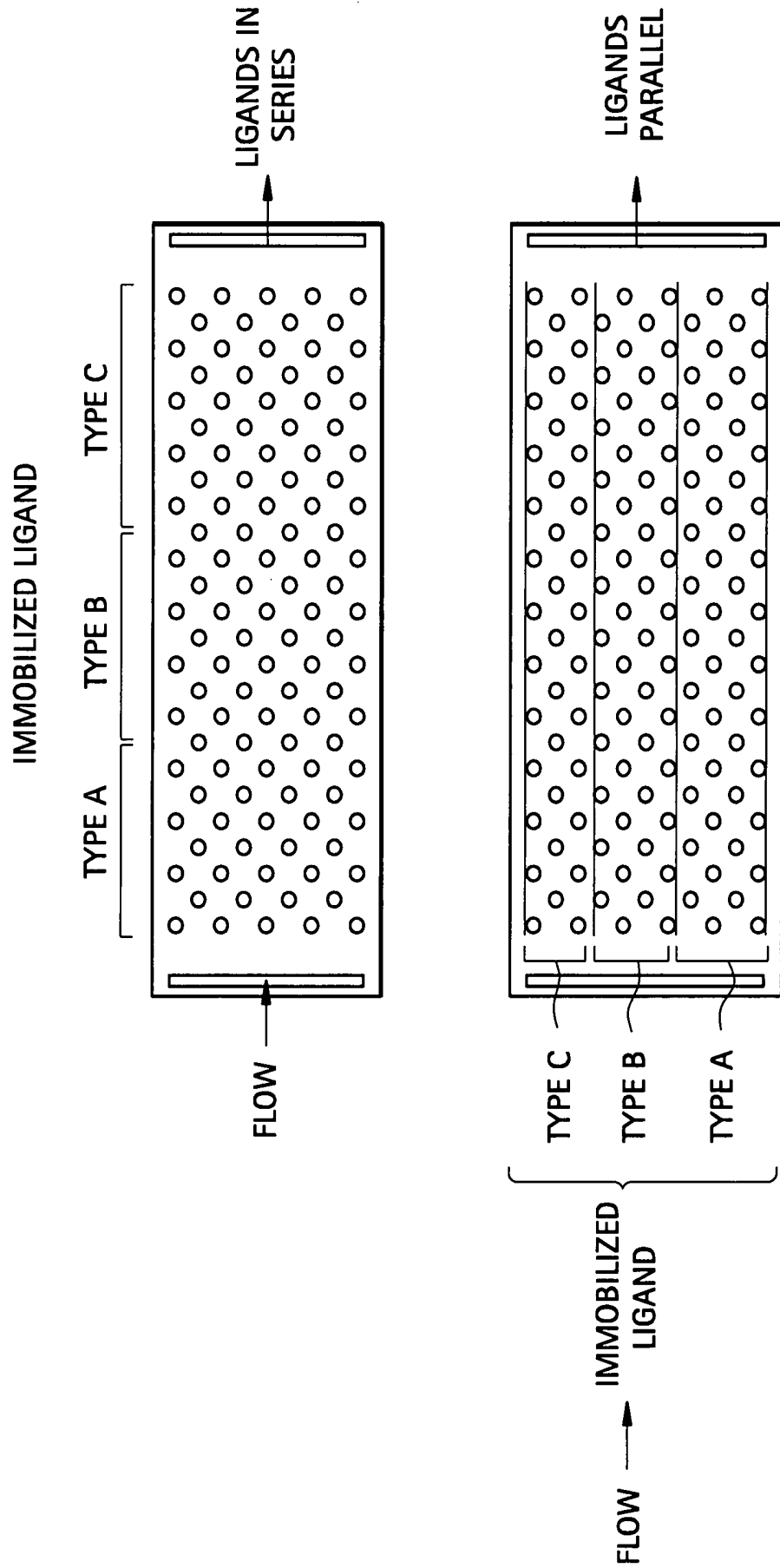

FIG. 21

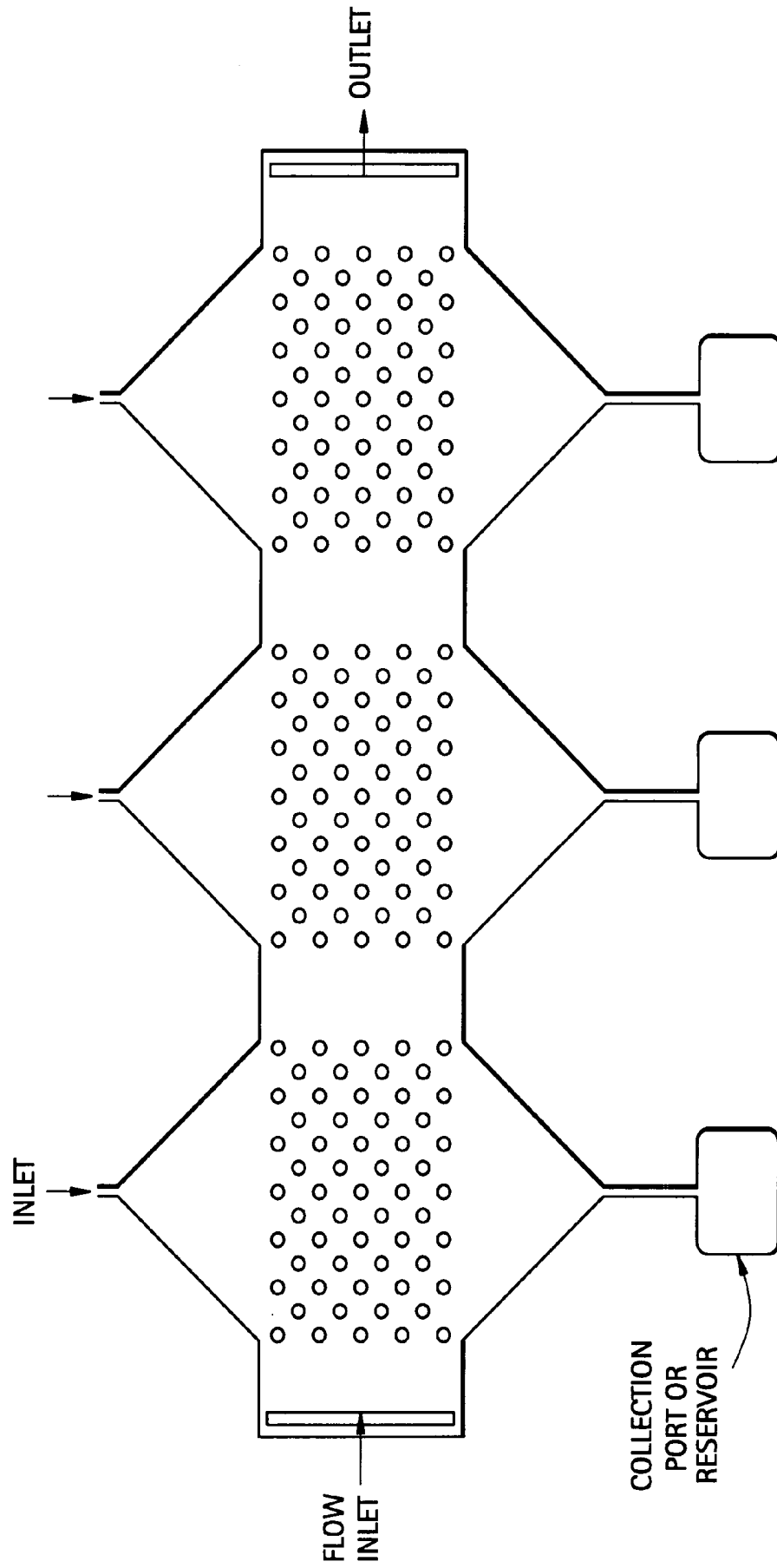

FIG. 22A

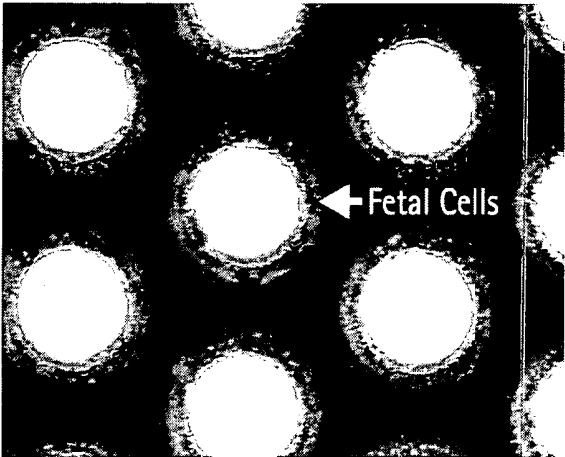

FIG. 22B



FIG. 22C

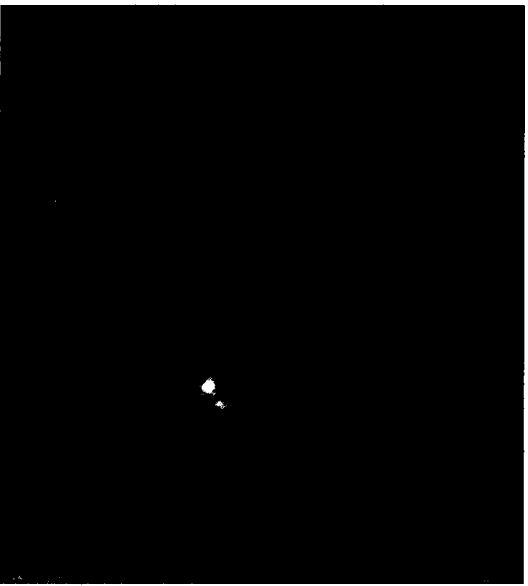

FIG. 23

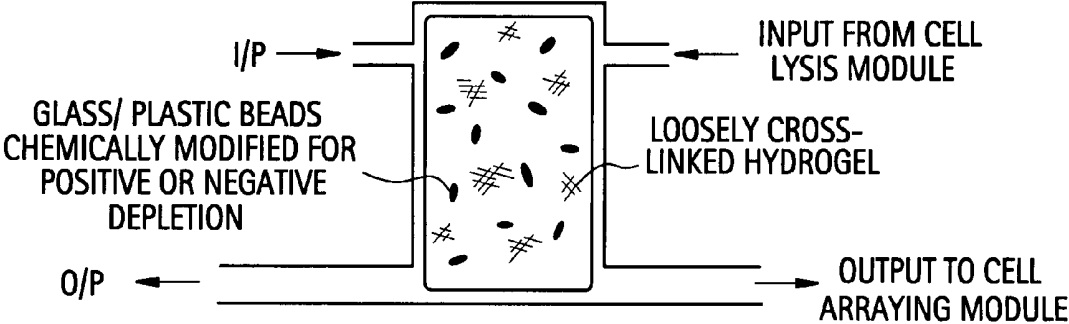



FIG. 24A

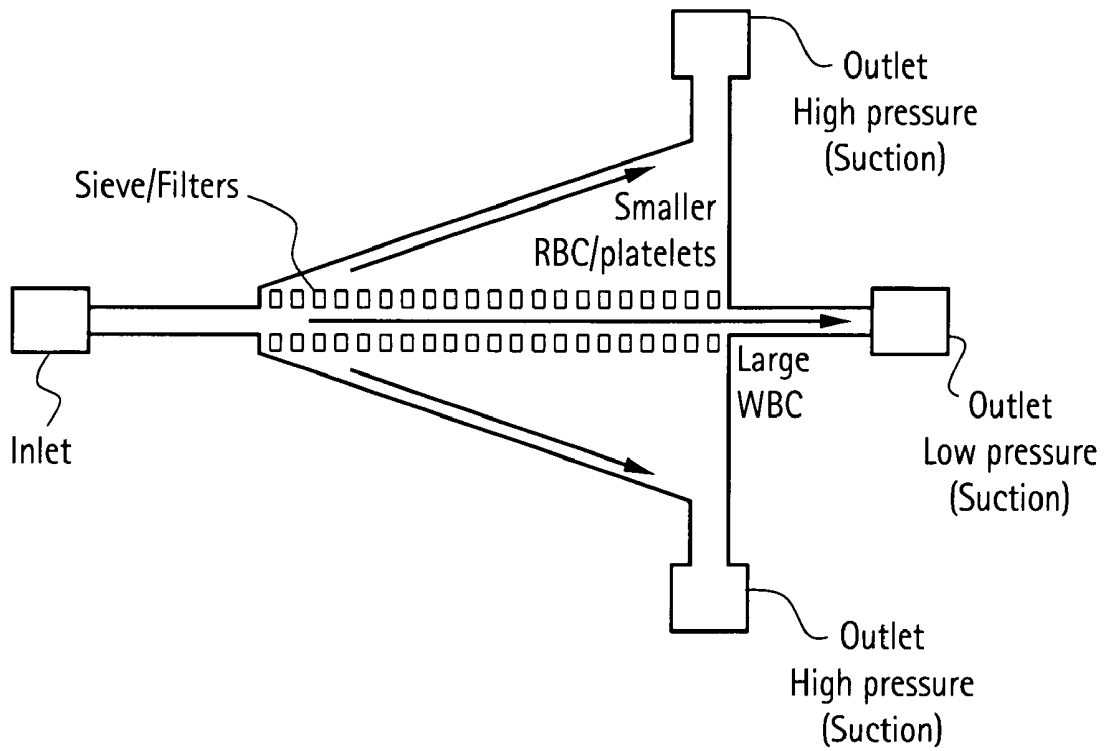

FIG. 24B

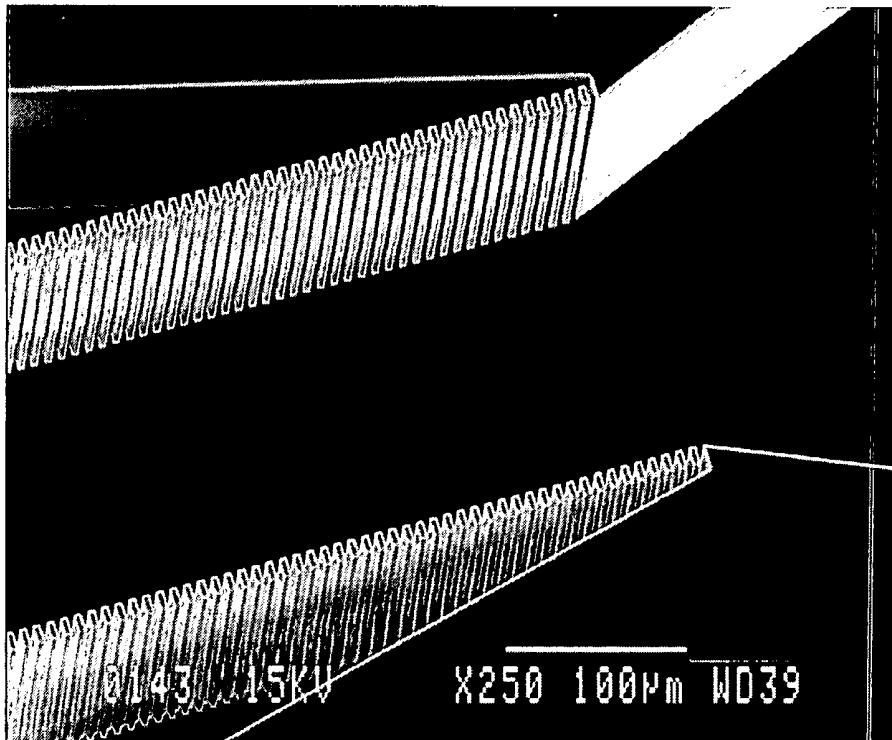
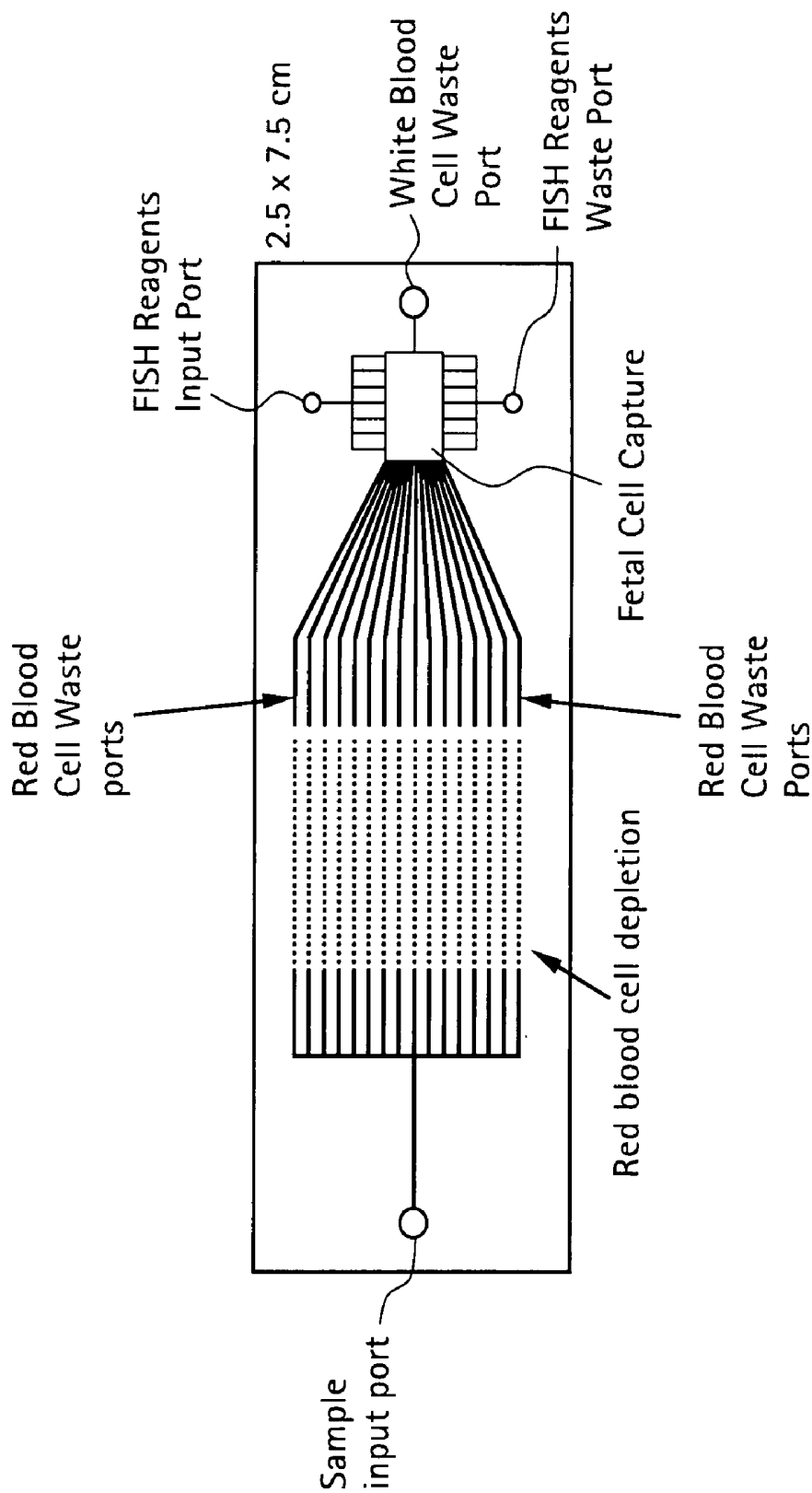

FIG. 25



## MICROFLUIDIC DEVICE FOR CELL SEPARATION AND USES THEREOF

### CROSS-REFERENCE TO RELATED APPLICATIONS

[0001] This application is a continuation of U.S. application Ser. No. 10/529,453, having a §371 date of Dec. 19, 2005, which is the National Stage of PCT/US03/30965, filed Sep. 29, 2003, which claims benefit of U.S. Provisional Application Nos. 60/414,065, 60/414,258, and 60/414,102, filed on Sep. 27, 2002, each of which is hereby incorporated by reference.

### BACKGROUND OF THE INVENTION

[0002] The invention relates to the fields of medical diagnostics and microfluidics.

[0003] There are several approaches devised to separate a population of homogeneous cells from blood. These cell separation techniques may be grouped into two broad categories: (1) invasive methods based on the selection of cells fixed and stained using various cell-specific markers; and (2) noninvasive methods for the isolation of living cells using a biophysical parameter specific to a population of cells of interest.

[0004] Invasive techniques include fluorescence activated cell sorting (FACS), magnetic activated cell sorting (MACS), and immunomagnetic colloid sorting. FACS is usually a positive selection technique that uses a fluorescently labeled marker to bind to cells expressing a specific cell surface marker. FACS can also be used to permeabilize and stain cells for intracellular markers that can constitute the basis for sorting. It is fast, typically running at a rate of 1,000 to 1,500 Hz, and well established in laboratory medicine. High false positive rates are associated with FACS because of the low number of photons obtained during extremely short dwell times at high speeds. Complicated multiparameter classification approaches can be used to enhance the specificity of FACS, but multianalyte-based FACS may be impractical for routine clinical testing because of the high cost associated with it. The clinical application of FACS is further limited because it requires considerable operator expertise, is laborious, results in cell loss due to multiple manipulations, and the cost of the equipment is prohibitive.

[0005] MACS is used as a cell separation technique in which cells that express a specific surface marker are isolated from a mixture of cells using magnetic beads coated with an antibody against the surface marker. MACS has the advantage of being cheaper, easier, and faster to perform as compared with FACS. It suffers from cell loss due to multiple manipulations and handling. Moreover, magnetic beads often autofluoresce and are not easily separated from cells. As a result, many of the immunofluorescence techniques used to probe into cellular function and structure are not compatible with this approach.

[0006] A magnetic colloid system has been used in the isolation of cells from blood. This colloid system uses ferromagnetic nanoparticles that are coated with goat anti-mouse IgG that can be easily attached to cell surface antigen-specific monoclonal antibodies. Cells that are labeled with ferromagnetic nanoparticles align in a magnetic

field along ferromagnetic Ni lines deposited by lithographic techniques on an optically transparent surface. This approach also requires multiple cell handling steps including mixing of cells with magnetic beads and separation on the surfaces. It is also not possible to sort out the individual cells from the sample for further analysis.

[0007] Noninvasive techniques include charge flow separation, which employs a horizontal crossflow fluid gradient opposing an electric field in order to separate cells based on their characteristic surface charge densities. Although this approach can separate cells purely on biophysical differences, it is not specific enough. There have been attempts to modify the device characteristics (e.g., separator screens, buffer counterflow conditions, etc.) to address this major shortcoming of the technique. None of these modifications of device characteristics has provided a practical solution given the expected individual variability in different samples.

[0008] Since the prior art methods suffer from high cost, low yield, and lack of specificity, there is a need for a method for depleting a particular type of cell from a mixture that overcomes these limitations.

### SUMMARY OF THE INVENTION

[0009] The invention features methods for separating cells from a sample (e.g., separating fetal red blood cells from maternal blood). The method begins with the introduction of a sample including cells into one or more microfluidic channels. In one embodiment, the device includes at least two processing steps. For example, a mixture of cells is introduced into a microfluidic channel that selectively allows the passage of a desired type of cell, and the population of cells enriched in the desired type is then introduced into a second microfluidic channel that allows the passage of the desired cell to produce a population of cells further enriched in the desired type. The selection of cells is based on a property of the cells in the mixture, for example, size, shape, deformability, surface characteristics (e.g., cell surface receptors or antigens and membrane permeability), or intracellular properties (e.g., expression of a particular enzyme).

[0010] In practice, the method may then proceed through a variety of processing steps employing various devices. In one step, the sample is combined with a solution in the microfluidic channels that preferentially lyses one type of cell compared to another type. In another step, cells are contacted with a device containing obstacles in a microfluidic channel. The obstacles preferentially bind one type of cell compared to another type. Alternatively, cells are arrayed individually for identification of the cells of interest. Cells may also be subjected to size, deformability, or shape based separations. Methods of the invention may employ only one of the above steps or any combination of the steps, in any order, to separate cells. The methods of the invention desirably recover at least 75%, 80%, 90%, 95%, 98%, or 99% of the desired cells in the sample.

[0011] The invention further features a microfluidic system for the separation of a desired cell from a sample. This system may include devices for carrying out one or any combination of the steps of the above-described methods. One of these devices is a lysis device that includes at least two input channels; a reaction chamber (e.g., a serpentine

channel); and an outlet channel. The device may additionally include another input and a dilution chamber (e.g., a serpentine channel). The lysis device is arranged such that at least two input channels are connected to the outlet through the reaction chamber. When a dilution chamber is present, it is disposed between the reaction chamber and the outlet, and another inlet is disposed between the reaction and dilution chambers. The system may also include a cell depletion device that contains obstacles that preferentially bind one type of cell when compared to another type, e.g., they are coated with anti-CD45, anti-CD36, anti-GPA, or anti-CD71 antibodies. The system may also include an arraying device that contains a two-dimensional array of locations for the containment of individual cells. The arraying device may also contain actuators for the selective manipulation (e.g., release) of individual cells in the array. Finally, the system may include a device for size based separation of cells. This device includes sieves that only allow passage of cells below a desired size. The sieves are located with a microfluidic channel through which a suspension of cells passes, as described herein. When used in combination, the devices in the system may be in liquid communication with one another. Alternatively, samples that pass through a device may be collected and transferred to another device.

[0012] By “a depleted cell population” is meant a population of cells that has been processed to decrease the relative population of a specified cell type in a mixture of cells. Subsequently collecting those cells depleted from the mixture also leads to a sample enriched in the cells depleted.

[0013] By an “enriched cell population” is meant a population of cells that has been processed to increase the relative population of a specified cell type in a mixture of cells.

[0014] By “lysis buffer” is meant a buffer that, when contacted with a population of cells, will cause at least one type of cell to lyse.

[0015] By “to cause lysis” is meant to lyse at least 90% of cells of a particular type.

[0016] By “not lysed” is meant less than 10% of cells of a particular type are lysed. Desirably, less than 5%, 2%, or 1% of these cells are lysed.

[0017] By “type” of cell is meant a population of cells having a common property, e.g., the presence of a particular surface antigen. A single cell may belong to several different types of cells.

[0018] By “serpentine channel” is meant a channel that has a total length that is greater than the linear distance between the end points of the channel. A serpentine channel may be oriented entirely vertically or horizontally. Alternatively, a serpentine channel may be “3D,” e.g., portions of the channel are oriented vertically and portions are oriented horizontally.

[0019] By “microfluidic” is meant having one or more dimensions of less than 1 mm.

[0020] By “binding moiety” is meant a chemical species to which a cell binds. A binding moiety may be a compound coupled to a surface or the material making up the surface. Exemplary binding moieties include antibodies, oligo- or polypeptides, nucleic acids, other proteins, synthetic polymers, and carbohydrates.

[0021] By “obstacle” is meant an impediment to flow in a channel, e.g., a protrusion from one surface.

[0022] By “specifically binding” a type of cell is meant binding cells of that type by a specified mechanism, e.g., antibody-antigen interaction. The strength of the bond is generally enough to prevent detachment by the flow of fluid present when cells are bound, although individual cells may occasionally detach under normal operating conditions.

[0023] By “rows of obstacles” is meant a series of obstacles arranged such that the centers of the obstacles are arranged substantially linearly. The distance between rows is the distance between the lines of two adjacent rows on which the centers are located.

[0024] By “columns of obstacles” is meant a series of obstacles arranged perpendicular to a row such that the centers of the obstacles are arranged substantially linearly. The distance between columns is the distance between the lines of two adjacent columns on which the centers are located.

[0025] The methods of the invention are able to separate specific populations of cells from a complex mixture without fixing and/or staining. As a result of obtaining living homogeneous population of cells, one can perform many functional assays on the cells. The microfluidic devices described herein provide a simple, selective approach for processing of cells.

[0026] Other features and advantages of the invention will be apparent from the following description and the claims.

#### BRIEF DESCRIPTION OF THE DRAWINGS

[0027] FIG. 1 is a schematic layout of a microfluidic device that enables selective lysis of cells.

[0028] FIG. 2 is an illustration of the channel layout for the introduction of three fluids to the device, e.g., blood sample, lysis buffer, and diluent.

[0029] FIG. 3 is an illustration of a repeating unit of the reaction chamber of the device where a sample of cells is passively mixed with a lysis buffer. In one example, 133 units are connected to form the reaction chamber.

[0030] FIG. 4 is an illustration of the outlet channels of the device.

[0031] FIG. 5 is an illustration of a device for cell lysis.

[0032] FIGS. 6A and 6B are illustrations of a method for the fabrication of a device of the invention.

[0033] FIG. 7 is a schematic diagram of a cell binding device.

[0034] FIG. 8 is an exploded view of a cell binding device.

[0035] FIG. 9 is an illustration of obstacles in a cell binding device.

[0036] FIG. 10 is an illustration of types of obstacles.

[0037] FIG. 11A is a schematic representation of a square array of obstacles. The square array has a capture efficiency of 40%. FIG. 11B is a schematic representation of an equilateral triangle array of obstacles. The equilateral triangle array has a capture efficiency of 56%.

[0038] FIG. 12A is a schematic representation of the calculation of the hydrodynamic efficiency for a square array. FIG. 12B is a schematic representation of the calculation of the hydrodynamic efficiency for a diagonal array

[0039] FIGS. 13A-13B are graphs of the hydrodynamic (13A) and overall efficiency (13B) for square array and triangular array for a pressure drop of 150 Pa/m. This pressure drop corresponds to a flow rate of 0.75 mL/hr in the planar geometry.

[0040] FIG. 14A is a graph of the overall efficiency as a function of pressure drop. FIG. 14B is a graph of the effect of the obstacle separation on the average velocity.

[0041] FIG. 15 is a schematic representation of the arrangement of obstacles for higher efficiency capture for an equilateral triangular array of obstacles in a staggered array. The capture radius  $r_{cap} = 0.339l$ . The obstacles are numbered such that the first number refers to the triangle number and the second number refers to the triangle vertex. The staggered array has a capture efficiency of 98%.

[0042] FIG. 16A is a graph of the percent capture of cells as a function of the flow rate for a 100  $\mu\text{m}$  diameter obstacle geometry with a 50  $\mu\text{m}$  edge-to-edge spacing. The operating flow regime was established across multiple cell types: cancer cells, normal connective tissue cells, and maternal and fetal samples. An optimal working flow regime is at 2.5 ml/hr. FIG. 16B is a graph of the percent capture of cells as a function of the ratio of targets cells to white blood cells. The model system was generated by spiking defined number of either cancer cells, normal connective tissue cells, or cells from cord blood into defined number of cells from buffy coat of adult blood. The ratio of the contaminating cells to target cells was incrementally increased 5 log with as few as 10 target cells in the mixture. Yield was computed as the difference between number of spiked target cells captured on posts and number of cells spiked into the sample.

[0043] FIG. 17 is an illustration of various views of the inlet and outlets of a cell binding device.

[0044] FIG. 18 is an illustration of a method of fabricating a cell binding device.

[0045] FIG. 19 is an illustration of a mixture of cells flowing through a cell binding device.

[0046] FIG. 20A is an illustration of a cell binding device for trapping different types of cells in series. FIG. 20B is an illustration of a cell binding device for trapping different types of cells in parallel.

[0047] FIG. 21 is an illustration of a cell binding device that enables recovery of bound cells.

[0048] FIG. 22A is an optical micrograph of fetal red blood cells adhered to an obstacle of the invention. FIG. 22B is a fluorescent micrograph showing the results of a FISH analysis of a fetal red blood cell attached to an obstacle of the invention. FIG. 22C is a close up micrograph of FIG. 22B showing the individual hybridization results for the fetal red blood cell.

[0049] FIG. 23 is an illustration of a cell binding device in which beads trapped in a hydrogel are used to capture cells.

[0050] FIG. 24A is an illustration of a device for size based separation. FIG. 24B is an electron micrograph of a device for size based separation.

[0051] FIG. 25 is a schematic representation of a device of the invention for isolating and analyzing fetal red blood cells.

[0052] Figures are not necessarily to scale.

#### DETAILED DESCRIPTION OF THE INVENTION

[0053] The invention features methods for separating a desired cell from a mixture or enriching the population of a desired cell in a mixture. The methods are generally based on sequential processing steps, each of which reduces the number of undesired cells in the mixture, but one processing step may be used in the methods of the invention. Devices for carrying out various processing steps may be separate or integrated into one microfluidic system. The devices of the invention are a device for cell lysis, a device for cell binding, a device for arraying cells, and a device for size, shape, or deformability based separation. In one embodiment, processing steps are used to reduce the number of cells prior to arraying. Desirably, the methods of the invention retain at least 75%, 80%, 90%, 95%, 98%, or 99% of the desired cells compared to the initial mixture, while potentially enriching the population of desired cells by a factor of at least 100, 1000, 10,000, 100,000, or even 1,000,000 relative to one or more non-desired cell types. The methods of the invention may be used to separate or enrich cells circulating in the blood (Table 1).

TABLE 1

Types, concentrations, and sizes of blood cells.		
Cell Type	Concentration (cells/ $\mu\text{l}$ )	Size ( $\mu\text{m}$ )
Red blood cells (RBC)	$4.2\text{-}6.1 \times 10^6$	4-6
Segmented Neutrophils (WBC)	3600	>10
Band Neutrophils (WBC)	120	>10
Lymphocytes (WBC)	1500	>10
Monocytes (WBC)	480	>10
Eosinophils (WBC)	180	>10
Basophils (WBC)	120	>10
Platelets	$500 \times 10^3$	1-2
Fetal Nucleated Red Blood Cells	$2\text{-}50 \times 10^3$	8-12

#### Devices

##### A. Cell Lysis

[0054] One device of the invention is employed to lysis of a population of cells selectively, e.g., maternal red blood cells, in a mixture of cells, e.g., maternal blood. This device allows for the processing of large numbers of cells under nearly identical conditions. The lysis device desirably removes a large number of cells prior to further processing. The debris, e.g., cell membranes and proteins, may be trapped, e.g., by filtration or precipitation, prior to any further processing.

[0055] Device. A design for a lysis device of the invention is shown in FIG. 1. The overall branched architecture of the channels in the device permits equivalent pressure drops across each of the parallel processing networks. The device can be functionally separated into four distinct sections: 1) distributed input channels carrying fluids, e.g., blood, lysis reagent, and wash buffer, to junctions 1 and 2 (FIG. 2); 2) a

serpentine reaction chamber for the cell lysis reaction residing between the two junctions (FIG. 3); 3) a dilution chamber downstream of Junction 2 for dilution of the lysis reagent (FIG. 3); and 4) distributed output channels carrying the lysed sample to a collection vial or to another microfluidic device (FIG. 4).

**[0056]** Input/Output Channels. The branched input and output networks of channels enable even distribution of the reagents into each of the channels (8, as depicted in FIG. 1). The three ports for interfacing the macro world with the device typically range in diameter from 1 mm-10 mm, e.g., 2, 5, 6, or 8 mm. Air tight seals may be formed with ports 1, 2, and 3, e.g., through an external manifold integrated with the device (FIG. 1). The three solution vials, e.g., blood, lysing reagent, and diluent, may interface with such a manifold. The input channels from ports 1, 2, and 3 to the reaction and mixing chambers, for the three solutions shown in FIG. 1, may be separated either in the z-plane of the device (three layers, each with one set of distribution channels, see FIG. 2) or reside in the external manifold. If residing in the external manifold, the distribution channels are, for example, CNC (computer numerically controlled) machined in stainless steel and may have dimensions of 500  $\mu\text{m}$  diameter. The manifold may hermetically interface with the device at ports that are etched into locations 1', 2', and 3' shown in FIG. 1. Locating the distribution channels in a manifold reduces the complexity and cost of the device. Retaining the distribution channels on the device will allow greater flexibility in selecting smaller channel size, while avoiding any issues of carry-over contamination between samples. Each sample input channel may have a separate output, or as depicted in FIG. 4, the output channels for each sample input are combined. As an alternative to a manifold, tubing for each fluid input or output may be attached to the device, e.g., by compression fitting to gaskets or nipples or use of watertight connections such as a luer lock. The channels on the device transporting the fluids to the mixing junctions and chambers beyond, can range from 10  $\mu\text{m}$ -500  $\mu\text{m}$  in width and depth, e.g., at most 10  $\mu\text{m}$ , 25  $\mu\text{m}$ , 50  $\mu\text{m}$ , 75  $\mu\text{m}$ , 100  $\mu\text{m}$ , 150  $\mu\text{m}$ , 200  $\mu\text{m}$ , 250  $\mu\text{m}$ , 350  $\mu\text{m}$ , or 450  $\mu\text{m}$  width and depth. The channel architecture is desirably rectangular but may also be circular, semi-circular, V-shaped, or any other appropriate shape. In one embodiment, the output channel (or channels) has a cross-sectional area equal to the sum of the cross-sectional areas of the input channels.

**[0057]** Reaction and Dilution Chambers. For lysis and dilution, two fluid streams are combined and allowed to pass through the chambers. Chambers may be linear or serpentine channels. In the device depicted in FIG. 1, the sample and lysis buffer are combined at junction 1, and the lysed sample and the diluent are combined at junction 2. Serpentine architecture of the reaction chamber and dilution chamber enables sufficient resident time of the two reacting solutions for proper mixing by diffusion or other passive mechanisms, while preserving a reasonable overall footprint for the device (FIG. 3). The serpentine channels may be constructed in 2D or in 3D, e.g., to reduce the total length of the device or to introduce chaotic advection for enhanced mixing. For short residence times, a linear chamber may be desired. Exemplary resident times include at least 1 second, 5 seconds, 10 seconds, 30 seconds, 60 second, 90 seconds, 2 minutes, 5 minutes, 30 minutes, 1 hour, or greater than 1 hour. The flow rate of fluids in the reaction/dilution cham-

bers can be accurately controlled by controlling the width, depth, and effective length of the channels to enable sufficient mixing of the two reagents while enabling optimal processing throughput. In one embodiment, the serpentine mixing chambers for cell lysis (reaction chamber) and for dilution of the lysed sample (dilution chamber) have a fluid volume each of  $\sim 26 \mu\text{l}$ . Other examples of reaction/dilution chamber volumes range from 10-200  $\mu\text{l}$ , e.g., at most 20, 50, 100, or 150  $\mu\text{l}$ . In some embodiments, the width and depth of the reaction and dilution chambers have the same range as the input and output channels, i.e., 10 to 500  $\mu\text{m}$ . Alternatively, the chambers may have a cross-sectional area equal to the combined areas of any input (or output channels) in order to ensure a uniform velocity of flow through the device. In one example, the chambers are 100  $\mu\text{m}$   $\times$  100  $\mu\text{m}$  channels. The total length of the chambers may be at least 1 cm, 5 cm, 10 cm, 20 cm, 30 cm, 40 cm, or 50 cm.

**[0058]** For lysis of maternal RBCs, device output flow rates may range from processing 5-16  $\mu\text{l}$  of blood per second resulting in a 20-60 minute processing time for 20 ml sample, or 10-30 min processing time for 10 ml sample. It is expected that the sample volume required for capturing sufficient number of fetal cells will be lower than 10 ml because of the efficiency of the process. As such, it is expected that the device throughput per sample will be less than 10 minutes. A residence time of  $>30$  seconds from the time of convergence of the two solutions, maternal blood and lysis reagent, within the passive mixer is deemed sufficient to obtain effective hemolysis (T. Maren, *Mol. Pharmacol.* 1970, 6:430). Alternatively, the concentration of the lysis reagent can be adjusted to compensate for residence time in the reaction chamber. The flow rates and residence times for other cell types may be determined by theory or experimentation. In one embodiment, the flow rates in each channel are limited to  $<20 \mu\text{l}/\text{sec}$  to ensure that wall shear stress on cells is less than 1  $\text{dyne}/\text{cm}^2$  (cells are known to be affected functionally by shear stress  $>1 \text{ dyne}/\text{cm}^2$  though deleterious effects are not seen in most cells until after 10  $\text{dynes}/\text{cm}^2$ ). In one embodiment, the flow rate in each channel is at most 1, 2, 5, 10, 15  $\mu\text{l}/\text{sec}$ . Referring to FIG. 1, the effective length of the diluent input channel leading to junction 2 may be shorter than the effective length of the reaction chamber. This feature enables the diluent to flow into and prime the channels downstream of junction 2, prior to arrival of the lysed sample at junction 2. The overflow buffer pre-collected in the output vial may act as a secondary diluent of the lysed sample when collected, e.g., for further processing or analysis. Additionally, the diluent primes the channels downstream of junction 2 to enable smoother flow and merging of the lysed sample with the buffer in the diluting chamber, and this priming eliminates any deleterious surface tension effects from dry channels on the lysed sample. The diameter of the channels carrying the diluent may be adjusted to enable the diluent to reach junction 2 at the same time as the lysed blood to prevent any problems associated with air forced from the reaction chamber as the sample and lysis buffers are introduced.

**[0059]** Although the above description focuses on a device with eight parallel processing channels, any number of channels, e.g., 1, 2, 4, 16, or 32, may be employed depending on the size of the device. The device is described in terms of combining two fluids for lysis and dilution, but three or more fluids may be combined for lysis or dilution. The combination may be at one junction or a series of junctions, e.g., to

control the timing of the sequential addition of reactants. Additional fluid inputs may be added, e.g., to functionalize the remaining cells, alter the pH, or cause undesirable components to precipitate. In addition, the exact geometry and dimensions of the channels may be altered (exemplary dimensions are shown in FIG. 5). Devices of the invention may be disposable or reusable. Disposable devices reduce the risk of contamination between samples. Reusable devices may be desirable in certain instances, and the device may be cleaned, e.g., with various detergents and enzymes, e.g., proteases or nucleases, to prevent contamination.

**[0060]** Pumping. In one embodiment, the device employs negative pressure pumping, e.g., using syringe pumps, peristaltic pumps, aspirators, or vacuum pumps. The negative pressure allows for processing of the complete volume of a clinical blood sample, without leaving unprocessed sample in the channels. Positive pressure, e.g., from a syringe pump, peristaltic pump, displacement pump, column of fluid, or other fluid pump, may also be used to pump samples through a device. The loss of sample due to dead volume issues related to positive pressure pumping may be overcome by chasing the residual sample with buffer. Pumps are typically interfaced to the device via hermetic seals, e.g., using silicone gaskets.

**[0061]** The flow rates of fluids in parallel channels in the device may be controlled in unison or separately. Variable and differential control of the flow rates in each of channels may be achieved, for example, by employing, a multi-channel individually controllable syringe manifold. In this embodiment, the input channel distribution will be modified to decouple all of the parallel networks. The output may collect the output from all channels via a single manifold connected to a suction (no requirements for an airtight seal) outputting to a collection vial or to another microfluidic device. Alternately, the output from each network can be collected separately for downstream processing. Separate inputs and outputs allow for parallel processing of multiple samples from one or more individuals.

**[0062]** Fabrication. A variety of techniques can be employed to fabricate a device of the invention, and the technique employed will be selected based in part on the material of choice. Exemplary materials for fabricating the devices of the invention include glass, silicon, steel, nickel, poly(methylmethacrylate) (PMMA), polycarbonate, polystyrene, polyethylene, polyolefins, silicones (e.g., poly(dimethylsiloxane)), and combinations thereof. Other materials are known in the art. Methods for fabricating channels in these materials are known in the art. These methods include, photolithography (e.g., stereolithography or x-ray photolithography), molding, embossing, silicon micromachining, wet or dry chemical etching, milling, diamond cutting, Lithographie Galvanoformung and Abformung (LIGA), and electroplating. For example, for glass, traditional silicon fabrication techniques of photolithography followed by wet (KOH) or dry etching (reactive ion etching with fluorine or other reactive gas) can be employed. Techniques such as laser micromachining can be adopted for plastic materials with high photon absorption efficiency. This technique is suitable for lower throughput fabrication because of the serial nature of the process. For mass-produced plastic devices, thermoplastic injection molding, and compression molding is suitable. Conventional thermoplastic injection molding used for mass-fabrication of compact discs (which

preserves fidelity of features in sub-microns) may also be employed to fabricate the devices of the invention. For example, the device features are replicated on a glass master by conventional photolithography. The glass master is electroformed to yield a tough, thermal shock resistant, thermally conductive, hard mold. This mold serves as the master template for injection molding or compression molding the features into a plastic device. Depending on the plastic material used to fabricate the devices and the requirements on optical quality and throughput of the finished product, compression molding or injection molding may be chosen as the method of manufacture. Compression molding (also called hot embossing or relief imprinting) has the advantages of being compatible with high-molecular weight polymers, which are excellent for small structures, but is difficult to use in replicating high aspect ratio structures and has longer cycle times. Injection molding works well for high-aspect ratio structures but is most suitable for low molecular weight polymers.

**[0063]** A device may be fabricated in one or more pieces that are then assembled. In one embodiment, separate layers of the device contain channels for a single fluid, as in FIG. 1. Layers of a device may be bonded together by clamps, adhesives, heat, anodic bonding, or reactions between surface groups (e.g., wafer bonding). Alternatively, a device with channels in more than one plane may be fabricated as a single piece, e.g., using stereolithography or other three-dimensional fabrication techniques.

**[0064]** In one embodiment, the device is made of PMMA. The features, for example those shown in FIG. 1, are transferred onto an electroformed mold using standard photolithography followed by electroplating. The mold is used to hot emboss the features into the PMMA at a temperature near its glass transition temperature (105° C.) under pressure (5 to 20 tons) (pressure and temperature will be adjusted to account for high-fidelity replication of the deepest feature in the device) as shown schematically in FIG. 6A. The mold is then cooled to enable removal of the PMMA device. A second piece used to seal the device, composed of similar or dissimilar material, may be bonded onto the first piece using vacuum-assisted thermal bonding. The vacuum prevents formation of air-gaps in the bonding regions. FIG. 6B shows a cross-section of the two-piece device assembly at the junction of Port 1 (source for blood sample) and feed channel.

**[0065]** Chemical Derivatization. To reduce non-specific adsorption of cells or compounds released by lysed cells onto the channel walls, one or more channel walls may be chemically modified to be non-adherent or repulsive. The walls may be coated with a thin film coating (e.g., a monolayer) of commercial non-stick reagents, such as those used to form hydrogels. Additional examples chemical species that may be used to modify the channel walls include oligoethylene glycols, fluorinated polymers, organosilanes, thiols, poly-ethylene glycol, hyaluronic acid, bovine serum albumin, poly-vinyl alcohol, mucin, poly-HEMA, methacrylated PEG, and agarose. Charged polymers may also be employed to repel oppositely charged species. The type of chemical species used for repulsion and the method of attachment to the channel walls will depend on the nature of the species being repelled and the nature of the walls and the species being attached. Such surface modification tech-

niques are well known in the art. The walls may be functionalized before or after the device is assembled.

[0066] The channel walls may also be coated in order to capture materials in the sample, e.g., membrane fragments or proteins.

[0067] Methods. In the present invention, a sample of cells, e.g., maternal blood, is introduced into one or more microfluidic channels. A lysis buffer containing reagents for the selective lysis for a population of cells in the sample is then mixed with the blood sample. Desirably, the mixing occurs by passive means, e.g., diffusion or chaotic advection, but active means may be employed. Additional passive and active mixers are known in the art. The lysis reaction is allowed to continue for a desired length of time. This length of time may be controlled, for example, by the length of the channels or by the rate of flow of the fluids. In addition, it is possible to control the volumes of solutions mixed in the channels by altering the relative volumetric flow rates of the solutions, e.g., by altering the channel size or velocity of flow. The flow may be slowed down, increased, or stopped for any desired period of time. After lysis has occurred, a diluent may be introduced into the channel in order to reduce the concentration of the lysis reagents and any potentially harmful species (e.g., endosomal enzymes) released by the lysed cells. The diluent may contain species that neutralize the lysis reagents or otherwise alter the fluid environment, e.g., pH or viscosity, or it may contain reagents for surface or intracellular labeling of cells. The diluent may also reduce the optical density of the solution, which may be important for certain detection schemes, e.g., absorbance measurements.

[0068] Exemplary cell types that may be lysed using the methods described herein include adult red blood cells, white blood cells (such as T cells, B cells, and helper T cells), infected white blood cells, tumor cells, and infectious organisms (e.g., bacteria, protozoa, and fungi). Lysis buffers for these cells may include cell specific IgM molecules and proteins in the complement cascade to initiate complement mediated lysis. Another kind of lysis buffer may include viruses that infect a specific cell type and cause lysis as a result of replication (see, e.g., Pawlik et al. *Cancer* 2002, 95:1171-81). Other lysis buffers are known in the art.

[0069] A device of the invention may be used for the selective lysis of maternal red blood cells (RBCs) in order to enrich a blood sample in fetal cells. In this example, a maternal blood sample, 10-20 ml, is processed within the first one to three hours after sample collection. If the processing is delayed beyond three hours, the sample may be stored at 4° C. until it is processed. The lysis device of the invention allows mixing of the lysis reagent (NH<sub>4</sub>Cl (0 to 150 mM)+NaHCO<sub>3</sub> (0.001 to 0.3 mM)+acetazolamide (0.1 to 100 μM)) with the maternal blood to enable selective lysis of the maternal red blood cells by the underlying principle of the Orskov-Jacobs-Stewart reaction (see, for example, Boyer et al. *Blood* 1976, 47:883-897). The high selective permeability of the carbonic anhydrase inhibitor, acetazolamide, into fetal cells enables selective hemolysis of the maternal red blood cells. Endogenous carbonic anhydrase in the maternal cells converts HCO<sub>3</sub><sup>-</sup> to carbon dioxide, which lyses the maternal red blood cells. The enzyme is inhibited in the fetal red blood cells, and those cells are not lysed. A diluent (e.g., phosphate buffered saline) may be added after

a period of contact between the lysis reagents and the cell sample to reduce the risk that a portion of the fetal red blood cells will be lysed after prolonged exposure to the reagents.

#### B. Cell Binding

[0070] Another device of the invention involves depletion of whole cells from a mixture by binding the cells to the surfaces of the device. The surfaces of such a device contain substances, e.g., antibodies or ligands for cell surface receptors, that bind a particular subpopulation of cells. This step in method may employ positive selection, i.e., the desired cells are bound to the device, or it may employ negative selection, i.e., the desired cells pass through the device. In either case, the population of cells containing the desired cells is collected for analysis or further processing.

[0071] Device. The device is a microfluidic flow system containing an array of obstacles of various shapes that are capable of binding a population of cells, e.g., those expressing a specific surface molecule, in a mixture. The bound cells may be directly analyzed on the device or be removed from the device, e.g., for further analysis or processing. Alternatively, cells not bound to the obstacles may be collected, e.g., for further processing or analysis.

[0072] An exemplary device is a flow apparatus having a flat-plate channel through which cells flow; such a device is described in U.S. Pat. No. 5,837,115. FIG. 7 shows an exemplary system including an infusion pump to perfuse a mixture of cells, e.g., blood, through the microfluidic device. Other pumping methods, as described herein, may be employed. The device may be optically transparent, or have transparent windows, for visualization of cells during flow through the device. The device contains obstacles distributed, e.g., in an ordered array or randomly, throughout the flow chamber. The top and bottom surfaces of the device are desirably parallel to each other. This concept is depicted in FIG. 8. The obstacles may be either part of the bottom or the top surface and desirably define the height of the flow channel. It is also possible for a fraction of the obstacles to be positioned on the bottom surface, and the remainder on the top surface. The obstacles may contact both the top and bottom of the chamber, or there may be a gap between an obstacle and one surface. The obstacles may be coated with a binding moiety, e.g., an antibody, a charged polymer, a molecule that binds to a cell surface receptor, an oligo- or polypeptide, a viral or bacterial protein, a nucleic acid, or a carbohydrate, that binds a population of cells, e.g., those expressing a specific surface molecule, in a mixture. Other binding moieties that are specific for a particular type of cell are known in the art. In an alternative embodiment, the obstacles are fabricated from a material to which a specific type of cell binds. Examples of such materials include organic polymers (charged or uncharged) and carbohydrates. Once a binding moiety is coupled to the obstacles, a coating, as described herein, may also be applied to any exposed surface of the obstacles to prevent non-specific adhesion of cells to the obstacles.

[0073] A geometry of obstacles is shown in FIG. 9. In one example, obstacles are etched on a surface area of 2 cm×7 cm on a substrate with overall dimensions of 2.5 cm×7.5 cm. A rim of 2 mm is left around the substrate for bonding to the top surface to create a closed chamber. In one embodiment, obstacle diameter is 50 μm with a height of 100 μm. Obstacles may be arranged in a two-dimensional array of



rows with a 100  $\mu\text{m}$  distance from center-to-center. This arrangement provides 50  $\mu\text{m}$  openings for cells to flow between the obstacles without being mechanically squeezed or damaged. The obstacles in one row are desirably shifted, e.g., 50  $\mu\text{m}$  with respect to the adjacent rows. This alternating pattern may be repeated throughout the design to ensure increased collision frequency between cells and obstacles. The diameter, width, or length of the obstacles may be at least 5, 10, 25, 50, 75, 100, or 250  $\mu\text{m}$  and at most 500, 250, 100, 75, 50, 25, or 10  $\mu\text{m}$ . The spacing between obstacles may be at least 10, 25, 50, 75, 100, 250, 500, or 750  $\mu\text{m}$  and at most 1000, 750, 500, 250, 100, 75, 50, or 25  $\mu\text{m}$ . Table 2 lists exemplary spacings based on the diameter of the obstacles.

TABLE 2

Exemplary spacings for obstacles.	
Obstacle diameter ( $\mu\text{m}$ )	Spacing between obstacles ( $\mu\text{m}$ )
100	50
100	25
50	50
50	25
10	25
10	50
10	15

[0074] The dimensions and geometry of the obstacles may vary significantly. For example, the obstacles may have cylindrical or square cross sections (FIG. 10). The distance between obstacles may also vary and may be different in the flow direction compared to the direction orthogonal to the flow. In some embodiments, the distance between the edges of the obstacles is slightly larger than the size of the largest cell in the mixture. This arrangement enables flow of cells without them being mechanically squeezed between the obstacles and thus damaged during the flow process, and also maximizes the numbers of collisions between cells and the obstacles in order to increase the probability of binding. The flow direction with respect to the orientation of the obstacles may also be altered to enhance interaction of cells with obstacles.

[0075] Exemplary arrangements of obstacles are shown in FIGS. 11A-11B. Each of these arrangements has a calculated capture efficiency. The calculation of cell attachment considered two different geometries: a square array (FIG. 11A), and an equilateral triangular array (FIG. 11B). Overall, results are presented in terms of the efficiency of adhesion. The calculations consist of two parts, computing the hydrodynamic efficiency ( $\eta$ ) and the probability of adhesion. The hydrodynamic efficiency was determined as the ratio of the capture radius to the half-distance between the cylinders (FIGS. 12A and 12B). For the square array,  $\eta = (2 r_{\text{cap}} / l) * 100\%$ , and for other arrays,  $\eta = ((r_{\text{cap}1} + r_{\text{cap}2}) / d_1) * 100\%$ , where  $d_1 = d_2 = l / \sqrt{2}$  for a diagonal square array, and  $d_1 = l\sqrt{3}/2$ ,  $d_2 = l/2$  for a triangular array. The probability of adhesion represents the fraction of cells that can resist the applied force on the cell assuming an average of 1.5 bonds per cell and 75 pN per bond.

[0076] For the triangular array, more cells adhered to the second set of obstacles than the first set. FIGS. 13A-13B show that the efficiency declines as the spacing between

obstacles increases. As the spacing increases there is a larger region outside the capture radius and the cells never contact the obstacles. Further, for the flow rates examined (0.25-1 mL/h), the overall probability of adhesion is high because the force per cell is less than the force to break the bonds.

[0077] For a triangular array and a spacing of 150 microns, the overall efficiency of capture drops 12% as the flow rate increases from 0.25 to 1 mL/h (FIGS. 14A-14B). Adhesion is not improved by going to lower flow rates since hydrodynamic capture is not improved. The mean velocity increases as the spacing between obstacles increases. The reason for this is that the calculations used a constant pressure drop. This differs from the experiments in which the flow rate is held fixed and the pressure drop varies. The results may be extrapolated from one case to another by one skilled in the art.

[0078] A repeating triangular array provides limited capture of target cells because most of the capture occurs in the first few rows. The reason for this is that the flow field becomes established in these rows and repeats. The first capture radius does not produce much capture whereas most of the capture is within the second capture radius (FIG. 15). Once cells within the capture radii are captured, the only way in which capture could occur is through cell-cell collisions to shift cells off their streamlines or secondary capture. With reference to FIG. 15, in order to enhance capture, after the flow field is established, the rows are shifted by a distance in the vertical direction (normal to flow) by a distance equal to  $r_{\text{cap}2} = 0.339l$ . The first five columns form two regular regions of equilateral triangles. This allows the flow to be established and be consistent with the solution for an equilateral triangular array. To promote capture of cells that fall outside  $r_{\text{cap}2}$ , the fourth column is shifted downward by a distance  $r_{\text{cap}2}$ . All columns are separated by a distance equal to  $l/2$ . A cell which falls outside  $r_{\text{cap}2}$  is shown being captured by the first obstacle in the fourth triangle (seventh column). Triangles 4 and 5 would be equilateral. In triangle 6, the vertex 3 is shifted downward by a distance  $r_{\text{cap}2}$ . This arrangement may be repeated every third triangle, i.e., the repeat distance is 2.5  $l$ . FIGS. 16A and 16B illustrate the efficiency of capture as a function of flow rate and relative population of the desired cells.

[0079] The top layer is desirably made of glass and has two slits drilled ultrasonically for inlet and outlet flows. The slit inlet/outlet dimensions are, for example, 2 cm long and 0.5 mm wide. FIG. 17 shows the details for the inlet/outlet geometry. A manifold may then be incorporated onto the inlet/outlet slits. The inlet manifold accepts blood cells from an infusion syringe pump or any other delivery vehicle, for example, through a flexible, biocompatible tubing. Similarly the outlet manifold is connected to a reservoir to collect the solution and cells exiting the device.

[0080] The inlet and outlet configuration and geometry may be designed in various ways. For example, circular inlets and outlets may be used. An entrance region devoid of obstacles is then incorporated into the design to ensure that blood cells are uniformly distributed when they reach the region where the obstacles are located. Similarly, the outlet is designed with an exit region devoid of obstacles to collect the exiting cells uniformly without damage.

[0081] The overall size of an exemplary device is shown in FIG. 9 (top inset). The length is 10 cm and the width is

5 cm. The area that is covered with obstacles is 9 cm×4.5 cm. The design is flexible enough to accommodate larger or smaller sizes for different applications.

**[0082]** The overall size of the device may be smaller or larger, depending on the flow throughput and the number of cells to be depleted (or captured). A larger device could include a greater number of obstacles and a larger surface area for cell capture. Such a device may be necessary if the amount of sample, e.g., blood, to be processed is large.

**[0083]** Fabrication. An exemplary method for fabricating a device of the invention is summarized in FIG. 18. In this example, standard photolithography is used to create a photoresist pattern of obstacles on a silicon-on-insulator (SOI) wafer. A SOI wafer consists of a 100 μm thick Si(100) layer atop a 1 μm thick SiO<sub>2</sub> layer on a 500 μm thick Si(100) wafer. To optimize photoresist adhesion, the SOI wafers may be exposed to high-temperature vapors of hexamethyldisilazane prior to photoresist coating. UV-sensitive photoresist is spin coated on the wafer, baked for 30 minutes at 90° C., exposed to UV light for 300 seconds through a chrome contact mask, developed for 5 minutes in developer, and post-baked for 30 minutes at 90° C. The process parameters may be altered depending on the nature and thickness of the photoresist. The pattern of the contact chrome mask is transferred to the photoresist and determines the geometry of the obstacles.

**[0084]** Upon the formation of the photoresist pattern that is the same as that of the obstacles, the etching is initiated. SiO<sub>2</sub> may serve as a stopper to the etching process. The etching may also be controlled to stop at a given depth without the use of a stopper layer. The photoresist pattern is transferred to the 100 μm thick Si layer in a plasma etcher. Multiplexed deep etching may be utilized to achieve uniform obstacles. For example, the substrate is exposed for 15 seconds to a fluorine-rich plasma flowing SF<sub>6</sub>, and then the system is switched to a fluorocarbon-rich plasma flowing only C<sub>4</sub>F<sub>8</sub> for 10 seconds, which coats all surfaces with a protective film. In the subsequent etching cycle, the exposure to ion bombardment clears the polymer preferentially from horizontal surfaces and the cycle is repeated multiple times until, e.g., the SiO<sub>2</sub> layer is reached.

**[0085]** To couple a binding moiety to the surfaces of the obstacles, the substrate may be exposed to an oxygen plasma prior to surface modification to create a silicon dioxide layer, to which binding moieties may be attached. The substrate may then be rinsed twice in distilled, deionized water and allowed to air dry. Silane immobilization onto exposed glass is performed by immersing samples for 30 seconds in freshly prepared, 2% v/v solution of 3-[(2-aminoethyl)amino]propyltrimethoxysilane in water followed by further washing in distilled, deionized water. The substrate is then dried in nitrogen gas and baked. Next, the substrate is immersed in 2.5% v/v solution of glutaraldehyde in phosphate buffered saline for 1 hour at ambient temperature. The substrate is then rinsed again, and immersed in a solution of 0.5 mg/mL binding moiety, e.g., anti-CD71, anti-CD36, anti-GPA, or anti-CD45, in distilled, deionized water for 15 minutes at ambient temperature to couple the binding agent to the obstacles. The substrate is then rinsed twice in distilled, deionized water, and soaked overnight in 70% ethanol for sterilization.

**[0086]** There are multiple techniques other than the method described above by which binding moieties may be

immobilized onto the obstacles and the surfaces of the device. Simple physio-absorption onto the surface may be the choice for simplicity and cost. Another approach may use self-assembled monolayers (e.g., thiols on gold) that are functionalized with various binding moieties. Additional methods may be used depending on the binding moieties being bound and the material used to fabricate the device. Surface modification methods are known in the art. In addition, certain cells may preferentially bind to the unaltered surface of a material. For example, some cells may bind preferentially to positively charged, negatively charged, or hydrophobic surfaces or to chemical groups present in certain polymers.

**[0087]** The next step involves the creation of a flow device by bonding a top layer to the microfabricated silicon containing the obstacles. The top substrate may be glass to provide visual observation of cells during and after capture. Thermal bonding or a UV curable epoxy may be used to create the flow chamber. The top and bottom may also be compression fit, for example, using a silicone gasket. Such a compression fit may be reversible. Other methods of bonding (e.g., wafer bonding) are known in the art. The method employed may depend on the nature of the materials used.

**[0088]** The cell binding device may be made out of different materials. Depending on the choice of the material different fabrication techniques may also be used. The device may be made out of plastic, such as polystyrene, using a hot embossing technique. The obstacles and the necessary other structures are embossed into the plastic to create the bottom surface. A top layer may then be bonded to the bottom layer. Injection molding is another approach that can be used to create such a device. Soft lithography may also be utilized to create either a whole chamber made out of poly(dimethylsiloxane) (PDMS), or only the obstacles may be created in PDMS and then bonded to a glass substrate to create the closed chamber. Yet another approach involves the use of epoxy casting techniques to create the obstacles through the use of UV or temperature curable epoxy on a master that has the negative replica of the intended structure. Laser or other types of micromachining approaches may also be utilized to create the flow chamber. Other suitable polymers that may be used in the fabrication of the device are polycarbonate, polyethylene, and poly(methyl methacrylate). In addition, metals like steel and nickel may also be used to fabricate the device of the invention, e.g., by traditional metal machining. Three-dimensional fabrication techniques (e.g., stereolithography) may be employed to fabricate a device in one piece. Other methods for fabrication are known in the art.

**[0089]** Methods. The methods of the invention involve contacting a mixture of cells with the surfaces of a microfluidic device. A population of cells in a complex mixture of cells such as blood then binds to the surfaces of the device. Desirably, at least 60%, 70%, 80%, 90%, 95%, 98%, or 99% of cells that are capable of binding to the surfaces of the device are removed from the mixture. The surface coating is desirably designed to minimize nonspecific binding of cells. For example, at least 99%, 98%, 95%, 90%, 80%, or 70% of cells not capable of binding to the binding moiety are not bound to the surfaces of the device. The selective binding in the device results in the separation of a specific living cell population from a mixture of cells. Obstacles are present in

the device to increase surface area for cells to interact with while in the chamber containing the obstacles so that the likelihood of binding is increased. The flow conditions are such that the cells are very gently handled in the device without the need to deform mechanically in order to go in between the obstacles. Positive pressure or negative pressure pumping or flow from a column of fluid may be employed to transport cells into and out of the microfluidic devices of the invention. In an alternative embodiment, cells are separated from non-cellular matter, such as non-biological matter (e.g., beads), non-viable cellular debris (e.g., membrane fragments), or molecules (e.g., proteins, nucleic acids, or cell lysates).

[0090] FIG. 19 shows cells expressing a specific surface antigen binding to a binding moiety coated onto obstacles, while other cells flow through the device (small arrow on cells depict the directionality of cells that are not bound to the surface). The top and bottom surfaces of the flow apparatus may also be coated with the same binding moiety, or a different binding moiety, to promote cell binding.

[0091] Exemplary cell types that may be separated using the methods described herein include adult red blood cells, fetal red blood cells, trophoblasts, fetal fibroblasts, white blood cells (such as T cells, B cells, and helper T cells), infected white blood cells, stem cells (e.g., CD34 positive hematopoietic stem cells), epithelial cells, tumor cells, and infectious organisms (e.g., bacteria, protozoa, and fungi).

[0092] Samples may be fractionated into multiple homogeneous components using the methods described herein. Multiple similar devices containing different binding moieties specific for a population of cells may be connected in series or in parallel. Serial separation may be employed when one seeks to isolate rare cells. On the other hand, parallel separation may be employed when one desires to obtain differential distribution of various populations in blood. FIGS. 20A and 20B show parallel and serial systems for the separation of multiple populations of cells from blood. For parallel devices, two or more sets of obstacles that bind different types of cells may be located in distinct regions or they may be interspersed among each other, e.g., in a checkerboard pattern or in alternating rows. In addition, a set of obstacles may be attached to the top of the device and another set may be attached to the bottom of the device. Each set may then be derivatized to bind different populations of cells. Once a sample has passed through the device, the top and bottom may be separated to provide isolated samples of two different types of cells.

[0093] The cell binding device may be used to deplete the outlet flow of a certain population of cells, or to capture a specific population of cells expressing a certain surface molecule for further analysis. The cells bound to obstacles may be removed from the chamber for further analysis of the homogeneous population of cells (FIG. 21). This removal may be achieved by incorporating one or more additional inlets and exits orthogonal to the flow direction. Cells may be removed from the chamber by purging the chamber at an increased flow rate, that is higher shear force, to overcome the binding force between the cells and the obstacles. Other approaches may involve coupling binding moieties with reversible binding properties, e.g., that are actuated by pH, temperature, or electrical field. The binding moiety, or the molecule bound on the surface of the cells, may also be cleaved by enzymatic or other chemical means.

[0094] In the example of fetal red blood cell isolation, a sample having passed through a lysis device is passed through a cell binding device, whose surfaces are coated with CD45. White blood cells expressing CD45 present in the mixture bind to the walls of the device, and the cells that pass through the device are enriched in fetal red blood cells. Alternatively, the obstacles and device surfaces are coated with anti-CD71 in order to bind fetal nucleated red blood cells (which express the CD71 cell surface protein) from a whole maternal blood sample. One percent of adult white blood cells also express CD71. A sample of maternal blood is passed through the device and both populations of cells that express CD71 bind to the device. This results in the depletion of fetal red blood cells from the blood sample. The fetal cells are then collected and analyzed. For example, cells are collected on a planar substrate for fluorescence in situ hybridization (FISH), followed by fixing of the cells and imaging. FIGS. 22A-22C show the use of FISH on a cell bound to an obstacle in a binding device of the invention. The cell, of fetal origin, is stained for X and Y chromosomes using fluorescent probes. These data show the feasibility of optical imaging of FISH stained cells on posts for detection and diagnosis of chromosomal abnormalities.

[0095] Alternative Embodiments. Another embodiment of the cell binding device utilizes chemically derivatized glass/plastic beads entrapped in a loosely cross-linked hydrogel, such as, but not limited to, poly(vinyl alcohol), poly(hydroxyl-ethyl methacrylate), polyacrylamide, or polyethylene glycol (FIG. 23). The chemically derivatized beads serve as the obstacles in this embodiment. A mixture of cells is directed into the cell depletion device via two diametrically opposed inputs. Positive pressure (e.g., from an infusion pump or column of fluid) or negative pressure (e.g., from a syringe pump in pull mode, a vacuum pump, or an aspirator) drives the liquid through the hydrogel. The interaction of the cells in the sample with the chemically derivatized beads dispersed in the three-dimensional volume of the hydrogel results in either depletion of cells, e.g., white blood cells, (negative selection) or capture of cells, e.g., fetal red blood cells, (positive selection). The molecular weight, cross-link density, bead density, and distribution and flow rates can be optimized to allow for maximal interaction and capture of relevant cells by the beads. The high-water content hydrogel provides a structure to trap the beads while allowing ease of flow through of the sample. The sample is then collected through two diametrically opposed outputs. The bifurcated input/output channel design assures maximal homogeneous distribution of the sample through the volume of the hydrogel.

[0096] In yet another embodiment, the beads are replaced by direct chemical derivatization of the side chains of the hydrogel polymer with the binding moiety (e.g., synthetic ligand or monoclonal antibody (mAb)). This approach can provide a very high density of molecular capture sites and thereby assure higher capture probability. An added advantage of this approach is a potential use of the hydrogel based cell depletion device as a sensor for fetal cell capture in the positive selection mode (select for fetal cells with specific mAb), for example, if the polymer backbone and side chain chemistry is designed to both capture the fetal cells and in the process further cross-link the hydrogel. The cells bind to numerous side chains via antigen-mAb interaction and thus serve as a cross-linker for the polymer chains, and the reduction in flow output over time due to increased polymer

cross-link density can be mathematically equated to the number of fetal cells captured within the 3D matrix of the polymer. When the desired number of fetal cells is captured (measured by reduction in output flow rate), the device can stop further processing of the maternal sample and proceed to analysis of the fetal cells. The captured fetal cells can be released for analysis by use of a photoactive coupling agent in the side chain. The photoreactive agent couples the target ligand or mAb to the polymer backbone, and on exposure to a pulse of UV or IR radiation, the ligands or mAbs and associated cells are released.

#### C. Cell Arraying

[0097] In this device, a mixture of cells that has typically been depleted of unwanted cells is arrayed in a microfluidic device. An exemplary device for this step is described in International Publication No. WO 01/35071. The cells in the array are then assayed, e.g., by microscopy or colorimetric assay, to locate desired cells. The desired cells may then be analyzed on the array, e.g., by lysis followed by PCR, or the cells may be collected from the array by a variety of mechanisms, e.g., optical tweezers. In the exemplary device described in WO 01/35071, the cells are introduced into the arraying device and may passively settle into holes machined in the device. Alternatively, positive or negative pressure may be employed to direct the cells to the holes in the array. Once the cells have been deposited in the holes, selected cells may be individually released from the array by actuators, e.g., bubble actuated pumps. Other methods for immobilizing and releasing cells, e.g., dielectrophoretic trapping, may also be used in an arraying device. Once released from the array, cells may be collected and subjected to analysis. For example, a fetal red blood cell is identified in the array and then analyzed for genetic abnormalities. Fetal red blood cells may be identified morphologically or by a specific molecular marker (e.g., fetal hemoglobin, transferrin receptor (CD71), thrombospondin receptor (CD36), or glycophorin A (GPA)).

#### D. Size-Based Separation

[0098] Another device is a device for the separation of particles based on the use of sieves that selectively allow passage of particles based on their size, shape, or deformability. The size, shape, or deformability of the pores in the sieve determines the types of cells that can pass through the sieve. Two or more sieves can be arranged in series or parallel, e.g., to remove cells of increasing size successively.

[0099] Device. In one embodiment, the sieve includes a series of obstacles that are spaced apart. A variety of obstacle sizes, geometries, and arrangements can be used in devices of the invention. Different shapes of obstacles, e.g., those with circular, square, rectangular, oval, or triangular cross sections, can be used in a sieve. The gap size between the obstacles and the shape of the obstacles may be optimized to ensure fast and efficient filtration. For example, the size range of the RBCs is on the order of 5-8  $\mu\text{m}$ , and the size range of platelets is on the order of 1-3  $\mu\text{m}$ . The size of all WBCs is greater than 10  $\mu\text{m}$ . Large gaps between obstacles increase the rate at which the RBCs and the platelets pass through the sieve, but increased gap size also increases the risk of losing WBCs. Smaller gap sizes ensure more efficient capture of WBCs but also a slower rate of passage for the RBCs and platelets. Depending on the type of application different geometries can be used.

[0100] In addition to obstacles, sieves may be manufactured by other methods. For example, a sieve could be formed by molding, electroforming, etching, drilling, or otherwise creating holes in a sheet of material, e.g., silicon, nickel, or PDMS. Alternatively, a polymer matrix or inorganic matrix (e.g., zeolite or ceramic) having appropriate pore size could be employed as a sieve in the devices described herein.

[0101] One problem associated with devices of the invention is clogging of the sieves. This problem can be reduced by appropriate sieve shapes and designs and also by treating the sieves with non-stick coatings such as bovine serum albumin (BSA) or polyethylene glycol (PEG), as described herein. One method of preventing clogging is to minimize the area of contact between the sieve and the particles.

[0102] The schematic of a low shear stress filtration device is shown in FIG. 24. The device has one inlet channel which leads into a diffuser, which is a widened portion of the channel. Typically, the channel widens in a V-shaped pattern. The diffuser contains two sieves having pores shaped to filter, for example, smaller RBCs and platelets from blood, while enriching the population of WBCs and fetal RBCs. The diffuser geometry widens the laminar flow streamlines forcing more cells to come in contact with the sieves while moving through the device. The device contains 3 outlets, two outlets collect cells that pass through the sieves, e.g., the RBCs and platelets, and one outlet collects the enriched WBCs and fetal RBCs.

[0103] The diffuser device typically does not ensure 100% depletion of RBCs and platelets. Initial RBC:WBC ratios of 600:1 can, however, be improved to ratios around 1:1. Advantages of this device are that the flow rates are low enough that shear stress on the cells does not affect the phenotype or viability of the cells and that the filters ensure that all the large cells (i.e., those unable to pass through the sieves) are retained such that the loss of large cells is minimized or eliminated. This property also ensures that the population of cells that pass through sieve do not contain large cells, even though some smaller cells may be lost. Widening the diffuser angle will result in a larger enrichment factor. Greater enrichment can also be obtained by the serial arrangement of more than one diffuser where the outlet from one diffuser feeds into the inlet of a second diffuser. Widening the gaps between the obstacles might expedite the depletion process at the risk of losing large cells through the larger pores in the sieves. For separating maternal red blood cells from fetal nucleated red blood cells, an exemplary spacing is 2-4  $\mu\text{m}$ .

[0104] Method. The device of the invention is a continuous flow cell sorter, e.g., that filters larger WBCs and fetal RBCs from blood. The location of the sieves in the device is chosen to ensure that the maximum number of particles come into contact with the sieves, while at the same time avoiding clogging and allowing for retrieval of the particles after separation. In general, particles are moved across their laminar flow lines which are maintained because of extremely low Reynolds number in the channels in the device, which are typically micrometer sized.

[0105] Fabrication. Simple microfabrication techniques like poly(dimethylsiloxane) (PDMS) soft lithography, polymer casting (e.g., using epoxies, acrylics, or urethanes), injection molding, polymer hot embossing, laser microma-

chining, thin film surface micromachining, deep etching of both glass and silicon, electroforming, and 3-D fabrication techniques such as stereolithography can be used for the fabrication of the channels and sieves of devices of the invention. Most of the above listed processes use photomasks for replication of micro-features. For feature sizes of greater than 5  $\mu\text{m}$ , transparency based emulsion masks can be used. Feature sizes between 2 and 5  $\mu\text{m}$  may require glass based chrome photomasks. For smaller features, a glass based E-beam direct write mask can be used. The masks are then used to either define a pattern of photoresist for etching in the case of silicon or glass or define negative replicas, e.g., using SU-8 photoresist, which can then be used as a master for replica molding of polymeric materials like PDMS, epoxies, and acrylics. The fabricated channels and may then be bonded onto a rigid substrate like glass to complete the device. Other methods for fabrication are known in the art. A device of the invention may be fabricated from a single material or a combination of materials.

**[0106]** Example. In one example, a device for size based separation of smaller RBCs and platelets from the larger WBCs was fabricated using simple soft lithography techniques. A chrome photomask having the features and geometry of the device was fabricated and used to pattern a silicon wafer with a negative replica of the device in SU-8 photoresist. This master was then used to fabricate PDMS channel and sieve structures using standard replica molding techniques. The PDMS device was bonded to a glass slide after treatment with  $\text{O}_2$  plasma. The diffuser geometry is used to widen the laminar flow streamlines to ensure that the majority of the particles or cells flowing through the device will interact with the sieves. The smaller RBC and platelets pass through the sieves, and the larger WBCs are confined to the central channel.

#### Combination of Devices

**[0107]** The devices of the invention may be used alone or in any combination. In addition, the steps of the methods described herein may be employed in any order. A schematic representation of a combination device for detecting and isolating fetal red blood cells is shown in FIG. 25. In one example, a sample may be processed using the cell lysis step, and then desired cells may be trapped in a cell binding device. If the cells trapped are sufficiently pure, no further processing step is needed. Alternatively, only one of the lysis or binding steps may be employed prior to arraying. In another example, a mixture of cells may be subjected to lysis, size based separation, binding, and arraying.

**[0108]** The methods of the invention may be carried out on one integrated device containing regions for cell lysis, cell binding, arraying, and size based separation. Alternatively, the devices may be separate, and the populations of cells obtained from each step may be collected and manually transferred to devices for subsequent processing steps.

**[0109]** Positive or negative pressure pumping may be used to transport cells through the microfluidic devices of the invention.

#### Analysis

**[0110]** After being enriched by one or more of the devices of the invention, cells may be collected and analyzed by various methods, e.g., nucleic acid analysis. The sample may also be further processed prior to analysis. In one example,

cells may be collected on a planar substrate for fluorescence in situ hybridization (FISH), followed by fixing of the cells and imaging. Such analysis may be used to detect fetal abnormalities such as Down syndrome, Edwards' syndrome, Patau's syndrome, Klinefelter syndrome, Turner syndrome, sickle cell anemia, Duchenne muscular dystrophy, and cystic fibrosis. The analysis may also be performed to determine a particular trait of a fetus, e.g., sex.

#### Other Embodiments

**[0111]** All publications, patents, and patent applications mentioned in the above specification are hereby incorporated by reference. Various modifications and variations of the described method and system of the invention will be apparent to those skilled in the art without departing from the scope and spirit of the invention. Although the invention has been described in connection with specific embodiments, it should be understood that the invention as claimed should not be unduly limited to such specific embodiments. Indeed, various modifications of the described modes for carrying out the invention that are obvious to those skilled in the art are intended to be within the scope of the invention.

**[0112]** Other embodiments are in the claims.

What is claimed is:

1. A method for detecting a non-hematopoietic cell in a blood sample, which method comprises:

- a) providing a blood sample;
- b) removing red blood cells (RBCs) from said blood sample, with the proviso that said RBCs are not removed from said blood sample via a Ficoll gradient centrifugation, and removing white blood cells (WBCs) from said blood sample to enrich a non-hematopoietic cell, if any, from said blood sample; and c) assessing the presence, absence and/or amount of said enriched non-hematopoietic cell.
2. The method of claim 1, wherein the non-hematopoietic cell to be detected is a non-hematopoietic tumor cell, a trophoblast, a bacterial cell or a fungal cell.
3. The method of claim 2, wherein the non-hematopoietic tumor cell is a cancerous cell or a cancer cell.
4. The method of claim 1, wherein the RBCs are removed by filtration, selective lysis, or binding to a specific binding member that specifically binds RBCs.
5. The method of claim 1, wherein the WBCs are removed by binding to a specific binding member that specifically binds WBCs.
6. The method of claim 5, wherein the specific binding member is an antibody that specifically binds to WBCs.
7. The method of claim 5, wherein the specific binding member is bound to a solid surface.
8. The method of claim 7, wherein the specific binding member is bound directly or indirectly to a solid surface.
9. The method of claim 7, wherein the solid surface is a magnetic particle.
10. The method of claim 1, wherein the RBCs are removed before the WBCs are removed from the blood sample.
11. The method of claim 1, wherein the WBCs are removed before the RBCs are removed from the blood sample.
12. The method of claim 1, which further comprises removing platelets from the blood sample.

13. The method of claim 1, wherein the presence, absence and/or amount of the enriched non-hematopoietic cell is assessed by labeling the enriched non-hematopoietic cell and identifying the labeled non-hematopoietic cell.

14. The method of claim 13, wherein the enriched non-hematopoietic cell is labeled by FISH or in situ hybridization.

15. The method of claim 13, wherein the labeled non-hematopoietic cell is identified by microscopic analysis, or flowcytometry.

16. The method of claim 1, wherein the presence, absence and/or amount of the enriched non-hematopoietic cell is assessed by assessing a non-hematopoietic marker in the enriched non-hematopoietic cell.

17. The method of claim 1, which comprises subjecting the enriched, labeled and/or non-hematopoietic cell to additional analysis.

18. The method of claim 1, which further comprises enriching the initially enriched non-hematopoietic cell.

19. The method of claim 18, wherein the initially enriched non-hematopoietic cell is further enriched by a positive selection of the non-hematopoietic cell or flowcytometry sorter.

20. The method of claim 1, wherein enriching a non-hematopoietic cell, if any, from said blood sample comprises flowing said sample through a device.

21. The method of claim 20, wherein said device comprises silicon.

22. The method of claim 20, wherein said device is chemically treated.

23. The method of claim 22, wherein chemical treatment is selected from among polyethylene glycol, bovine serum albumin and polyvinyl alcohol.

24. The method of claim 20, wherein said non-hematopoietic cell are enriched by binding to a binding moiety on said device.

25. The method of claim 24, wherein said binding moiety is an antibody.

26. The method of claim 1, wherein at least 75%, 80%, 90%, 95% or 99% of non-hematopoietic cell are enriched from said sample.

27. The method of claim 20, wherein flowing said sample through said device occurs at a rate of from 5  $\mu\text{L/hr}$  to 16  $\mu\text{L/hr}$ .

\* \* \* \* \*

专利名称(译)	用于细胞分离的微流体装置及其用途		
公开(公告)号	<a href="#">US20070264675A1</a>	公开(公告)日	2007-11-15
申请号	US11/800940	申请日	2007-05-08
[标]申请(专利权)人(译)	通用医疗公司		
申请(专利权)人(译)	总医院CORPORATION		
当前申请(专利权)人(译)	总医院CORPORATION		
[标]发明人	TONER MEHMET TRUSKEY GEORGE KAPUR RAVI		
发明人	TONER, MEHMET TRUSKEY, GEORGE KAPUR, RAVI		
IPC分类号	C12Q1/02 G01N33/53 B01L3/00 B01L99/00 C12N5/00 C12N5/02 C12N5/06 G01N33/543 G01N33/569		
CPC分类号	B01L3/502746 Y10T428/24744 B01L9/54 B01L2200/0647 B01L2200/0668 B01L2300/0681 B01L2300/0816 B01L2300/0864 B01L2400/0487 B01L2400/086 B82Y30/00 C12N5/0087 G01N1/40 G01N33/5091 G01N33/54386 G01N33/56966 G01N33/574 G01N2333/70582 G01N2333/70589 G01N2333/70596 G01N2015/1081 G01N2015/1006 B01L3/502753 B01L1/52 B33Y70/00 B33Y80/00 Y10T29/49982 B01L3/502761 B01L2200/0652 B01L2200/12 B01L2300/0867 B01L2300/0877 B01L2300/0883 B01L2300/12 G01N1/405 G01N33/54366		
优先权	10/529453 2005-12-19 US PCT/US2003/030965 2003-09-29 WO 60/414065 2002-09-27 US 60/414258 2002-09-27 US 60/414102 2002-09-27 US		
其他公开文献	US8372579		
外部链接	<a href="#">Espacenet</a> <a href="#">USPTO</a>		

摘要(译)

本发明的特征在于从样品中分离细胞的方法（例如，将胎儿红细胞与母体血液分离）。该方法开始于将包括细胞的样品引入一个或多个微流体通道。在一个实施例中，该设备包括至少两个处理步骤。例如，将细胞混合物引入微流体通道中，该微流体通道选择性地允许所需类型的细胞通过，然后将富含所需类型的细胞群引入允许所需通过的第二微流体通道中。细胞产生进一步富集所需类型的细胞群。细胞的选择基于混合物中细胞的性质，例如，大小，形状，可变形性，表面特征（例如，细胞表面受体或抗原和膜渗透性），或细胞内特性（例如，特定的表达酶）。

