



US 20160349244A1

(19) **United States**

(12) **Patent Application Publication**
Zhang

(10) **Pub. No.: US 2016/0349244 A1**

(43) **Pub. Date: Dec. 1, 2016**

(54) **MULTI-UNIT PLATE FOR ELECTROBLOTTING AND IMMUNOBLOT ANALYSIS**

Publication Classification

(71) Applicant: **Jiandi Zhang**, Fairfax, VA (US)

(51) **Int. Cl.**
G01N 33/53 (2006.01)
B01L 3/00 (2006.01)

(72) Inventor: **Jiandi Zhang**, Fairfax, VA (US)

(52) **U.S. Cl.**
CPC *G01N 33/5304* (2013.01); *B01L 3/5085* (2013.01); *B01L 2300/0829* (2013.01); *B01L 2300/163* (2013.01); *B01L 2300/069* (2013.01)

(73) Assignee: **Zestern Biotechnology LLC**, Fairfax, VA (US)

(57) **ABSTRACT**

(21) Appl. No.: **14/721,205**

This invention is provided for multi-unit plate with at least one unit comprised of a membrane, preferably nitrocellulose or PVDF membrane, associated with a supporting structure to allow for electroblotting of the membrane. This multi-unit plate is suited for high throughput immunoblot analysis including Zestern analysis.

(22) Filed: **May 26, 2015**

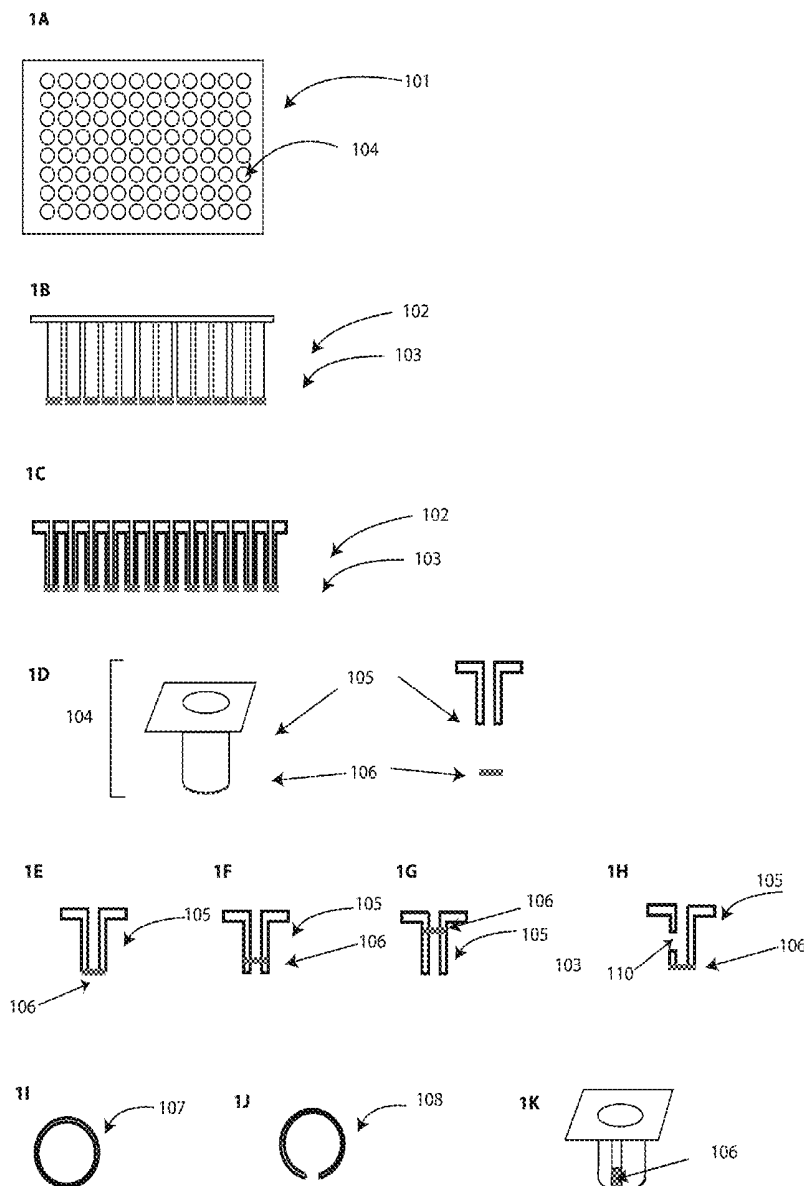

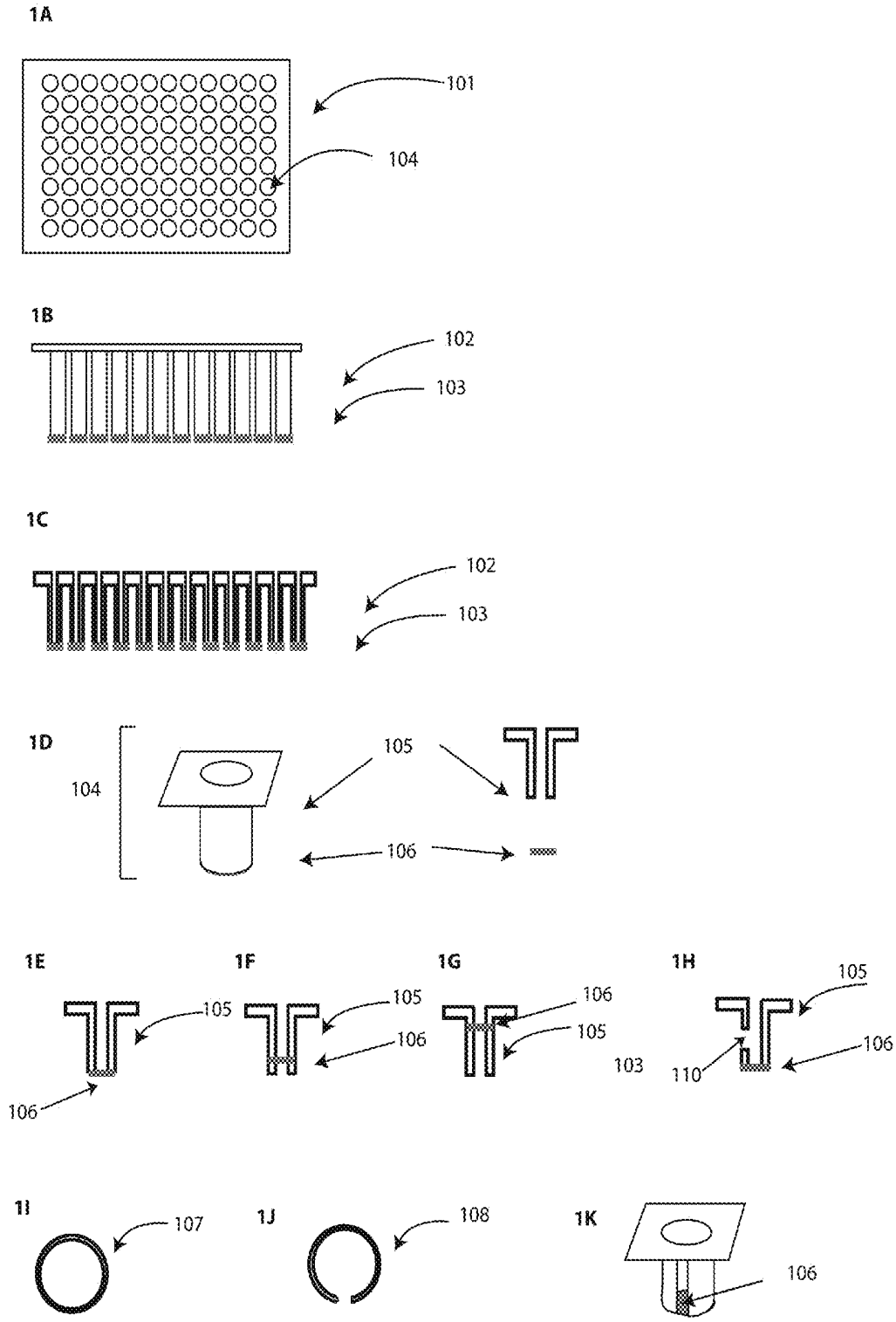

Fig. 1

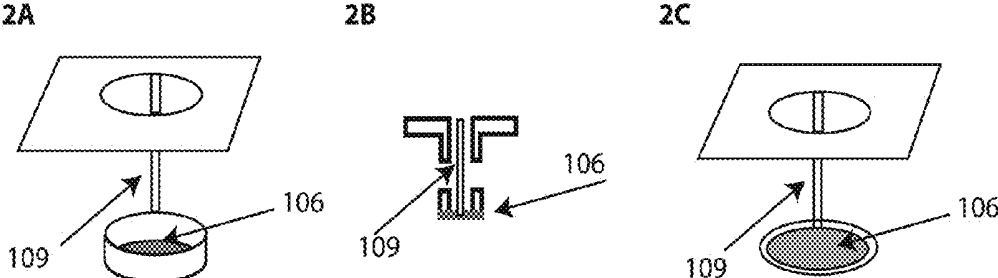

Fig. 2

MULTI-UNIT PLATE FOR ELECTROBLOTTING AND IMMUNOBLOT ANALYSIS

FIELD OF INVENTION

[0001] The present invention relates to the field of immunoblot analysis and more particularly, to device and method for high throughput immunoblot analysis. In one application, the present invention is of multi-unit plate and method for performing Zestern analysis in a multi-unit format.

BACKGROUND ART

[0002] Protein analysis is the foundation of modern biological research. Investigations of the expression and regulation of critical protein factors in biological processes and their applications in pharmaceutical and clinical studies provide vital information for experimental, pharmaceutical and clinical research of the pathogenesis of diseases and their prevention, diagnosis and treatments.

[0003] The recently patented Zestern technique (U.S. Pat. Nos. 8,293,487, 8,563,256 and 8,722,345) is an improvement of traditional methods of immunoblot-based protein analysis. While the protein samples are analyzed following a traditional immunoblotting process before detection, an additional step of elution is added in Zestern analysis to ensure the specificity of the assay. The antibody or antibody complex bound to the antigen of interest can be specifically competed out by competing molecule into elution solution. The amount of the eluted antibody or antibody complex in elution solution reflect the amount of antigen of interest in the sample to be analyzed. The total amount of eluted antibody or antibody complex can be quantified directly in solution, representing another advantage of Zestern analysis over traditional immunoblotting methods.

[0004] While Zestern analysis demonstrates advantage over traditional immunoblot methods for its simplicity and suitability for high throughput analysis, it poses new demand for suitable devices, as current existing devices for traditional immunoblot methods are not designed to meet the need of Zestern analysis, especially for high throughput purpose.

[0005] In traditional immunoblot analysis, represented by Western blot analysis, several types of membranes have been used and well optimized for immunoblot analysis. These membranes include both nitrocellulose membrane and PVDF membrane.

[0006] In traditional immunoblot analysis, the signal is detected on the very spot where the antibody or antibody complex bound to the antigen of interest on the membrane. This requires the membrane to be smooth and continuous to facilitate comparison of the detection results.

[0007] On the contrary, in Zestern analysis, antibody or antibody complex is liberated from the very spot where antibody or antibody complex bound to the antigen of interest by the competing molecule. The antibody or antibody complex is eluted from each spot respectively for quantification. Clearly, in Zestern analysis, the membrane cannot be continuous among protein samples. It must be separated from each other to allow elution of antibody or antibody complex for each protein sample separately, preventing cross-contamination of the signal from each other.

[0008] In Zestern analysis, for the membrane per se, there is no requirement regarding the shape or other physical

characteristics of the membrane, as detection of the signal from each sample is not being processed on the membrane per se.

[0009] Multi-well plate has been widely used in biochemical assays and immunoblotting assays including ELISA assays. These multi-well plates include 6, 24, 96, and even 1536 well plate. It can also be referred as microtiter plate, microplate, or microwell plate.

[0010] Multi-well plate for ELISA assay generally has protein binding capacity at less than $1 \mu\text{g}/\text{cm}^2$. In contrast, a typical membrane for traditional immunoblotting, regardless of nitrocellulose or PVDF membrane, has protein binding capacity of 100 to $200 \mu\text{g}/\text{cm}^2$. While ELISA plate has achieved success in ELISA assay, its low protein binding capacity limits its application in Zestern analysis.

[0011] In the prototype of immunoblot analysis, Dot blot analysis, the antigen is applied directly to the membrane, and the membrane is allowed to dry in the air over an extended period of time. This practice may not be the best form of sample application, for at least in routine practices, vacuum is applied to the membrane to increase the binding of the antigen to the membrane.

[0012] In Western blot analysis, antigen is trapped in the polyacrylamide gel during electrophoresis step. The trapped antigen is transferred to the membrane for blotting through a process called electroblotting.

[0013] In this invention, a multi-unit plate is designed both suitable for Zestern analysis and for electroblotting of the antigen to the membrane. Therefore, this invention provides solution to the unique demand of Zestern analysis for immunoblot analysis, especially for its application in multi-unit plate format. It also significantly increase the amount of antigen bound to the membrane due to electroblotting step.

SUMMARY OF THE INVENTION

[0014] The reference to the "present invention" or "invention" used herein relates to exemplary embodiments and not necessarily to every embodiment that is encompassed by the appended claims.

[0015] The present invention provides method and device and variations of the device for high throughput immunoblot analysis including Zestern analysis. While the devices may be different from each other, at least one unit within the multi-unit plate is comprised of a membrane associated with supporting structure for immunoblotting and electroblotting of protein sample in immunoblot analysis.

[0016] The supporting structure can be in any shape, as long as it serves the purpose to separate membrane of individual unit from each other within the multi-unit plate.

[0017] In Zestern analysis, membrane used for individual sample may be a piece of membrane, or pieces of membrane together in a unit of the multi-unit plate. The membrane is eluted in the elution step for quantification of the individual sample.

[0018] There is no limitation of the shape, texture or even the continuation of the membrane within the individual unit of multi-unit plate. Multiple pieces of membrane can be considered as one membrane as long as they are within one unit of multi-unit plate.

[0019] One method of Zestern analysis is to use multi-unit plate with at least one unit comprised of a membrane and supporting structure to allow immunoblot analysis and electroblotting. The membrane can associate with the supporting structure in any form, as long as the membrane of one unit

is separated from other unit within the multi-unit plate, and it allows the electroblotting process to happen.

[0020] One example of supporting structure is a hollow protrusion with opening on both ends as individual unit of multi-unit plate, and membrane is associated with the protrusion. The membrane can be at any position within the hollow protrusion. It may be in the middle inside the protrusion or at either ends of the hollow protrusion, including covering either end of the hollow protrusion.

[0021] The hollow protrusion may have opening on the sidewall of the unit to allow efficient washing of the membrane. It may have more than one opening on the sidewall of the unit. In one embodiment of the present invention, a whole section of the hollow structure in-between may be missing, and the separated sections of the hollow structure are connected by a pole-like structure. In another embodiment of the invention, the hollow protrusion may become a ring shape structure with a pole-like structure attached alongside to form the multi-unit plate. The membrane is associated with the ring structure.

[0022] In one embodiment of the invention, the rim where the supporting structure is in direct contact with the membrane is closed. In another embodiment of the invention, that rim is open. The preferred shape of the rim is circular. However, other shapes are acceptable as long as the multi-unit plate can fit into a multi-well plate.

[0023] The present invention may be combined with one conventional multi-well plate to complete Zestern analysis. The wall of individual well of the multi-well plate serves as physical barrier to prevent cross contamination of elution solution from each other.

[0024] The multi-unit plate is processed in a typical immunoblot process until at the elution step of the Zestern analysis, where it combines with a multi-well plate to allow for elution of antibodies from individual unit of multi-unit plate.

[0025] The multi-unit plate, until the elution step, can be processed individually, or it can be processed as a group. Nonetheless, at the elution step, the multi-unit plate needs to be used individually with a matching multi-well plate.

[0026] Preferably, the plurality of units of a plate of the present invention comprise $6n$ units arranged in a $2n$ by $3n$ array, where n is an integer greater than 0, the units preferably being arranged in rectangular packing. Preferred pluralities of units are the commonly known pluralities of units such as 6, 24, 96, 384 and 1536 units. More preferred are plates of 96 units and 384 units as these formats are most popular and have many available accessories including fluid handling accessories such as fluid-handling robots.

[0027] In one embodiment of the present invention, the individual unit in multi-unit plate can be individually addressable.

[0028] A multi-unit plate of the present invention is made of membrane and any suitable, non-electrically conductive material. Suitable materials include but are not limited to ceramics, elastomers, epoxies, glasses, glass-ceramics, plastics, polycarbonates, polydimethylsiloxane, polyurethane, polyethylenterephthalate glycol, polymers, polymethyl methacrylate, polystyrene, polyvinyl chloride, rubber, silicon, silicon oxide and silicon rubber.

[0029] There is no limitation of the shape or 3-dimensional structure of the membrane used in multi-unit plate as long as it allows accessibility of the samples of interest. In an embodiment of the present invention, the surface of the

membrane in one unit of multi-unit plate may be smooth. In another embodiment of the present invention, the surface of individual membrane may not be smooth.

[0030] In an embodiment of the present invention, the individual membrane may be treated before or after sample application to increase protein binding efficiency.

[0031] In an embodiment of the present invention, the multi-unit plate in combination with a multi-well plate can be used to analyze samples in traditional immunoblot analyses. A sample of interest is applied to membrane of an individual unit of the multi-unit plate of present invention, and the membrane is going through electroblotting, washing, antibody incubation, and washing steps before it is placed in a conventional multi-well plate for direct detection using a microplate reader and appropriate reagents.

[0032] Additional aspects of the invention will be set forth, in part, in the detailed description, figures, and any claims which follow, or can be learned by practice of the invention. It is to be understood that both the foregoing general description and the following detailed description are exemplary and explanatory only, and are not restrictive of the invention as disclosed.

BRIEF DESCRIPTION OF THE DRAWINGS

[0033] FIG. 1 shows an embodiment of multi-unit plate. 1A, top view of the multi-unit plate; 1B, side view of the multi-unit plate; 1C, cross-section view of the multi-unit plate; 1D, structure of an individual unit of multi-unit plate; including both the side view and cross-section view of an individual unit; 1E-1H, Several embodiments of individual unit of multi-unit plate; 1I-1J, embodiments of rim of supporting structure in direct contact with membrane; 1K, side view of individual unit with rim shown in FIG. 1J. 101, multi-unit plate of present invention; 102, overall supporting structure of multi-unit plate; 103, membrane associated with the overall supporting structure of multi-unit plate; 104, An individual unit of multi-unit plate include both the supporting structure of individual unit and membrane; 105, supporting structure of an individual unit; 106, membrane associated with supporting structure of an individual unit; 107, A closed rim of the supporting structure of an individual unit in contact with membrane; 108, An open rim of supporting structure of an individual unit in contact with membrane; 109, pole like structure to link two sections of the hollow structure together; 110, opening on the sidewall of an individual unit of multi-unit plate.

[0034] Drawing 2 show several other embodiments of individual unit of multi-unit plate; 2A, Front view of an individual unit; 2B, side view of an individual unit; 2C, another embodiment of an individual unit of multi-unit plate.

DETAILED DESCRIPTION OF THE INVENTION

[0035] Unless defined otherwise, all technical and scientific terms used herein have the same meaning as is commonly understood by one of skills in the art to which this invention belongs.

[0036] The present invention provides devices for immunoblot analysis including Zestern analysis. Zestern analysis distinguishes itself from traditional immunoblot analysis including Western blot analysis by its simplicity and suitability for multi-unit format. The elution step in Zestern

analysis requires elution solution for individual sample to be physically separated from each other to avoid cross-contamination of the result. In other word, each sample must be applied to individual membrane, and elution solution for individual sample must be limited to membrane within individual unit of multi-unit plate.

[0037] In an embodiment of present invention, device for Zestern analysis is shown in the drawing. A multi-unit plate **101** includes overall supporting structure **102** and membrane **103**. Membrane **103** is preferably either PVDF or nitrocellulose membrane.

[0038] Individual unit **104** includes both the supporting structure **105** and membrane **106**. The supporting structure **105** is hollow inside, with opening on both ends. Sample to be analyzed is applied directly on the membrane **106** within an individual unit **104**.

[0039] In one embodiment of the present invention, membrane **106** is at the bottom of the hollow supporting structure **105** of an individual unit of **104** as in FIG. 1E. In yet another embodiment of present invention, it is in the middle within the hollow supporting structure **105** of an individual unit of **104** as in FIG. 1F. In yet another embodiment of the invention, it is at the top part of the hollow supporting structure **105** of an individual unit **104**. In one embodiment of present invention, there may have an opening **110** on the sidewall of hollow supporting structure **105** of an individual unit **104**. In yet another embodiment of present invention, there may be more than one opening **110** on the sidewall of the supporting structure of an individual unit **104**.

[0040] In one embodiment of the present invention, the rim **107** of the supporting structure of an individual unit in direct contact with membrane **106** is closed, as shown in FIG. 1I. In yet another embodiment of the present invention, the rim **108** of the supporting structure of an individual unit in direct contact with membrane **106** is open, as shown in FIG. 1J and 1K.

[0041] In another embodiment of present invention, the whole section between the upper and lower parts of the sidewall of the hollow supporting structure **105** is missing, and the upper and lower parts of supporting structure are connected by a pole-like structure **109** in-between. In yet another embodiment of present invention, a membrane is attached to a ring shape structure, and this ring shape structure is connected to the multi-unit plate by a pole like structure **109**, as shown in FIG. 2C.

[0042] Preferably, a plate of the present invention has a footprint of a standard multi-well plate, so the multi-unit plate can fit inside a typical multi-well plate. Preferably, the plurality of units of a plate of the present invention comprise $6n$ units arranged in a $2n$ by $3n$ array, where n is an integer greater than 0, the units preferably being arranged in rectangular packing. Preferred pluralities of units are the commonly known pluralities of units such as 6, 24, 96, 384 and 1536 units. More preferred are plates of 96 units and 384 units as these formats are most popular and have many available accessories including fluid handling accessories such as fluid-handling robots.

[0043] The surface of the membrane **103** can be smooth, or it can be coarse. It can also have protrusions on the surface of the membrane.

[0044] The antigen is applied directly on the membrane of at least one unit of multi-unit plate for electroblotting. Those skilled in the art will know that membrane is permeable to allow the electroblotting process. Those skilled in the art

will know that while the pore of the membrane may vary, it must restrict the free passage of antigen of interest through the membrane.

[0045] The supporting structure **102** of multi-unit plate is made of any suitable, non-electrically conductive material. Suitable materials include but are not limited to ceramics, elastomers, epoxies, glasses, glass-ceramics, plastics, polycarbonates, polydimethylsiloxane, polyurethane, polyethylenterephthalate glycol, polymers, polymethyl methacrylate, polystyrene, polyvinyl chloride, rubber, silicon, silicon oxide and silicon rubber.

[0046] The multi-unit plate **101** with immunocomplex bound on the membrane **106** of individual unit of plate **104** is inserted into a typical multi-well plate after a typical immunoblotting process. Elution solution containing competing molecule is applied in individual well of multi-well plate to elute antibody or antibody complex from membrane **106** for quantification of the signals.

[0047] The membrane **106** of the individual unit of **104** is made of any suitable material with protein binding capacity comparable to nitrocellulose or PVDF membrane. The entire plate of the present invention can be made of one material, or it can be made of a number of different materials, for example, a plurality of layers.

[0048] As used herein "membrane" is to be taken in its broadest context. A membrane can be any material with sufficient surface porosity to allow access by detection antibodies and a suitable surface affinity to bind antigen. All these materials may be used in suitable shapes, or they can be coated onto, or bonded or laminated, or simply attached to appropriate supporting material, such as paper, glass, plastic materials, as long as it may not interfere with the electroblotting process. For example, membrane can be, but not limited to, nitrocellulose membrane or PVDF membrane.

[0049] Those skilled in the art will know how to prepare samples for immunoblot purpose. The samples include, but not limited to, a mixture of a chemical molecule, a peptide molecule, a protein molecule, an RNA molecule, a DNA molecule, a traditional antibody, e.g. two heavy chains and two light chains, a recombinant antibody or fragment, a cell, a virus particle, and a product comprising crosslinking any two or more of the above. The sample may be charged with appropriate sample buffer.

[0050] Those skilled in the art will know how to treat membrane for immunoblot analysis. These practices include, but not limited to, direct application of a sample to the membrane, or pre-wet the membrane with Ethanol, or Methanol, before sample application. The multi-unit plate with samples applied on the membrane may be left in the air to dry before going through a typical immunoblot process including electroblotting.

[0051] Those skilled in the art know how to prepare membrane for electroblotting. The membrane applied with sample is placed inside the transfer buffer under appropriate current to increase the amount of proteins bound onto the membrane.

[0052] As used herein "the conventional multi-well plate" is to be taken in its broadest context. The conventional multi-well plate can be any plate the multi-unit plate of present invention can fit inside to physically separate individual unit of multi-unit plate from each other.

[0053] Those skilled in the art will know how to process an individual membrane with a sample applied on the

surface for immunoblot process. These steps include blocking the individual membranes with blocking buffer, incubation with primary antibody, washing, incubation with secondary antibody and washing again to eliminate non-specific antibody bound to the membrane.

[0054] In yet another embodiment of present invention, the multi-unit plate of present invention can be used for traditional immunoblot analysis including ELISA analysis, Dot blot analysis, in cell western analysis and protein array analysis. The significantly increased binding capacity of the membrane, in combination with the significantly increased binding efficiency due to electroblotting, are suitable for high throughput immunoblot analysis.

[0055] A protein sample is applied to the membrane of an individual unit of multi-unit plate of present invention. The membrane is going through electroblotting and a series of typical immunoblot steps including blocking, primary antibody incubation, washing, secondary antibody incubation, and washing steps before it is placed in a conventional multi-well plate. The amount of antibodies bound on the membrane in individual unit of multi-unit plate of present invention can be detected using microplate reader by adding appropriate detection reagents to the individual well of multi-well plate containing the multi-unit plate of present invention, and the signal can be detected either directly in the individual well of multi-well plate containing the multi-unit plate of present invention, or the solution can be transferred from individual well of multi-well plate containing multi-unit plate of present invention into another multi-well plate for quantification using a microplate reader.

[0056] Although several embodiments of the present invention have been illustrated in the accompanying Drawings and described in the foregoing detailed description, it should be understood that the invention is not limited to the embodiments disclosed. It is appreciated that many alternatives, modifications and variations will be apparent to those skilled in the art. Accordingly, the present invention is intended to embrace all such alternatives, modifications and variations that fall within the spirit and broad scope of the appended claims.

[0057] The following examples of the method of invention are to further illustrate of the nature of the invention. It needs to be understood that the invention is not limited thereto.

EXAMPLE 1

[0058] Samples of interest are prepared using 4×SDS buffer (Laemmli buffer). The 96 unit plate of present invention is loaded with 6 μl of whole cell lysate of HEK-293 cells.

[0059] The multi-unit plate is subjected to electroblotting for 20 mins.

[0060] A typical immunoblot process, including steps of blocking, incubation with primary antibody, washing, incubation with secondary antibody, and washing, is performed using present invention of multi-unit plate. The secondary antibody is labeled with Horseradish peroxidase as the reporter enzyme for immunoblot analysis.

[0061] The multi-unit plate is placed into a multi-well plate containing elution buffer of competing molecule or TBS at 100 μl/well for 15 mins to liberate antibody complex from the membrane of multi-unit plate.

[0062] The elution buffer is transferred to a regular 96 well plate for quantification of the signaling using a typical chemiluminescence reporter assay kit (Millipore) with a microplate reader.

EXAMPLE 2

[0063] Samples of interest are prepared using 4×SDS buffer (Laemmli buffer). The 96 unit plate of present invention is loaded with 6 μl of whole cell lysate of HEK-293 cells.

[0064] The multi-unit plate is subjected to electroblotting for 20 mins.

[0065] A typical immunoblot process, including steps of blocking, incubation with primary antibody, washing, incubation with secondary antibody, and washing, is performed using multi-unit plate of present invention. The secondary antibody is labeled with Horseradish peroxidase as the reporter enzyme for immunoblot analysis.

[0066] The multi-unit plate is placed into a multi-well plate. TBS of 40 μl is mixed with prepared ECL solution (Millipore) at 1:1 ratio, and is added to the individual well of the multi-well plate holding the multi-unit plate of present invention.

[0067] After 10 mins, the ECL solution is transferred from the above-mentioned multi-well plate to a new multi-well plate at 60 μl/well for quantification using a microplate reader.

What I claimed:

1. A multi-unit device for immunoblot analysis comprising:

- a multi-well plate with a plurality of wells; and
- a complementing multi-unit plate sized to fit into multi-well plate; the multi-unit comprises of a plurality of protrusive units, with at least one said unit comprising
 - i). hollow structure with opening at sidewall; and
 - ii). a membrane associated with protrusive structure at the bottom,

Each protrusive structure is to support the associated membrane at the bottom while allowing efficient washing of the membrane through opening at sidewall. The structure is hollow for electroblotting of protein on the membrane.

2. (canceled)

3. The multi-unit plate of claim 1, having a footprint of a standard multi-well plate to allow its insertion into a matching multi-well plate.

4. The multi-unit plate of claim 1, wherein said plurality of units comprises 6n units arranged in a 2n×3n array, where n is an integer greater than 0.

5. The multi-unit plate of claim 1, wherein said plurality of units comprises individually addressable protrusions.

6. The multi-unit plate of claim 1, wherein the membrane is sufficiently porous to allow penetration by the detection antibody.

7. The multi-unit plate of claim 6 wherein the membrane is nitrocellulose or PVDF membrane.

8. (canceled)

9. The multi-unit plate of claim 1, comprising a non-electrically conductive material selected from the group consisting of ceramics, elastomers, epoxies, glasses, glass-ceramics, plastics, polycarbonates, polydimethylsiloxane, polyethyleneterephthalate glycol, polymers, polymethyl methacrylate, polystyrene, polyurethane, polyvinyl chloride, rubber, silicon, silicon oxide and silicon rubber.

10. (canceled)
11. (canceled)
12. (canceled)
13. A multi-unit device for immunoblot analysis comprising:
a multi-well plate with a plurality of wells; and
a complementing multi-unit plate sized to fit into multi-well plate; the multi-unit comprises of a plurality of protrusive units, with at least one said unit comprising
i), a ring shape supporting structure, connected by a rod-like structure with the plate;
ii), a membrane covering the ring shape structure;
The ring shape structure is to support the associated membrane while allowing efficient washing of the membrane and electroblotting.
14. (canceled)
15. (canceled)
16. (canceled)
17. The multi-unit plate of claim 13, having a footprint of a standard multi-well plate to allow its insertion into a matching multi-well plate.

18. The multi-unit plate of claim 13, wherein said plurality of units comprises $6n$ units arranged in a $2n \times 3n$ array, where n is an integer greater than 0.

19. The multi-unit plate of claim 13, wherein said plurality of units comprises individually addressable protrusions.

20. The multi-unit plate of claim 13, wherein the membrane is sufficiently porous to allow penetration by the detection antibody.

21. The multi-unit plate of claim 20, wherein the membrane is nitrocellulose or PVDF membrane.

22. The multi-unit plate of claim 13, comprising a non-electrically conductive material selected from the group consisting of ceramics, elastomers, epoxies, glasses, glass-ceramics, plastics, polycarbonates, polydimethylsiloxane, polyethyleneterephthalate glycol, polymers, polymethyl methacrylate, polystyrene, polyurethane, polyvinyl chloride, rubber.

* * * * *

专利名称(译)	用于电印迹和免疫印迹分析的多单元板		
公开(公告)号	US20160349244A1	公开(公告)日	2016-12-01
申请号	US14/721205	申请日	2015-05-26
[标]申请(专利权)人(译)	张润底		
申请(专利权)人(译)	张, 润底		
[标]发明人	ZHANG JIANDI		
发明人	ZHANG, JIANDI		
IPC分类号	G01N33/53 B01L3/00		
CPC分类号	G01N33/5304 B01L3/5085 B01L2300/069 B01L2300/163 B01L2300/0829		
其他公开文献	US9933418		
外部链接	Espacenet USPTO		

摘要(译)

本发明提供了多单元板，其具有至少一个由膜组成的单元，优选硝酸纤维素膜或PVDF膜，其与支撑结构相关联以允许膜的电印迹。该多单元板适用于包括Zestern分析在内的高通量免疫印迹分析。

