

(19)



(11)

**EP 3 036 545 B1**

(12)

**EUROPEAN PATENT SPECIFICATION**

(45) Date of publication and mention of the grant of the patent:  
**03.07.2019 Bulletin 2019/27**

(51) Int Cl.:  
**C12Q 1/6837 (2018.01) C12Q 1/6825 (2018.01)**  
**C12Q 1/6827 (2018.01) C12Q 1/6809 (2018.01)**

(21) Application number: **14838189.0**

(86) International application number:  
**PCT/US2014/051763**

(22) Date of filing: **19.08.2014**

(87) International publication number:  
**WO 2015/026873 (26.02.2015 Gazette 2015/08)**

**(54) ASSAYS FOR SINGLE MOLECULE DETECTION AND USE THEREOF**

ASSAYS ZUR EINZELMOLEKÜLDETEKTION UND VERWENDUNG DAVON

DOSAGES POUR DÉTECTION DE MOLÉCULE UNIQUE ET LEUR UTILISATION

(84) Designated Contracting States:  
**AL AT BE BG CH CY CZ DE DK EE ES FI FR GB GR HR HU IE IS IT LI LT LU LV MC MK MT NL NO PL PT RO RS SE SI SK SM TR**

- **COLLINS, Patrick James**  
San Francisco, CA 94158 (US)
- **HERSCHLEB, Jill Lyndon**  
San Francisco, CA 94158 (US)
- **JONES, Hywel Bowden**  
San Francisco, CA 94158 (US)

(30) Priority: **19.08.2013 US 201361867559 P**  
**19.08.2013 US 201361867554 P**

(43) Date of publication of application:  
**29.06.2016 Bulletin 2016/26**

(74) Representative: **Maschio, Antonio**  
**Maschio & Soames IP Limited**  
**30 Carlton Crescent**  
**Southampton SO15 2EW (GB)**

(73) Proprietor: **Singular Bio Inc.**  
**San Francisco, CA 94158 (US)**

(56) References cited:  
**WO-A1-2012/021749 WO-A2-2005/026329**  
**JP-A- 2009 232 778 US-A1- 2005 244 863**  
**US-A1- 2006 019 304 US-A1- 2008 138 809**  
**US-A1- 2013 072 390**

(72) Inventors:  
• **FEHR, Adrian Nielsen**  
**San Francisco, CA 94158 (US)**

**EP 3 036 545 B1**

Note: Within nine months of the publication of the mention of the grant of the European patent in the European Patent Bulletin, any person may give notice to the European Patent Office of opposition to that patent, in accordance with the Implementing Regulations. Notice of opposition shall not be deemed to have been filed until the opposition fee has been paid. (Art. 99(1) European Patent Convention).

**Description**

Background of the Invention

5 **[0001]** The invention relates to methods of detecting a genetic variation in a genetic sample from a subject. Detecting a genetic variation is important in many aspects of human biology.

Summary

10 **[0002]** The invention relates to methods of detecting a genetic variation in a genetic sample from a subject. The invention further relates to methods of detecting a genetic variation in a genetic sample from a subject using labeled probes and counting the number of labels in the probes.

Brief Description of the Drawings

15 **[0003]**  
Figure 1 depicts exemplary array members comprising binding partners, tags, affinity tags, tagging probes, probe sets, and/or ligated probe sets described herein on a substrate.  
20

Figure 2 depicts a normalized histogram of signal intensity measured from both single label samples and multi-label antibodies.

25 Figure 3 depicts average bleaching profiles from various labels.

Figures 4-13 show the integrated label intensity graphs over time for various Alexa 488 labels.

30 Figure 14 depicts excitation spectrum and emission spectrum through a standard operation when excitation of a fluorophore is achieved by illuminating with a narrow spectral band aligned with the absorption maxima of that species.

Figure 15 depicts excitation spectrum and emission spectrum through interrogation with various excitation colors and collected emission bands different from (or in addition to) the case for the standard operation.

35 Figure 16 shows results when the light from these various imaging configurations, e.g., various emission filters, is collected and compared to calibration values for the fluorophores of interest.

Figure 17 shows results collected with various references, including those with a flat emission profile (Contaminant 1; triangles), or a blue-weighted profile (Contaminant 2; stars).

40 Figure 18 depicts significantly-different excitation bands of two fluorophores.

Figure 19 depicts an exemplary system flow chart.

45 Figure 20 depicts an exemplary system flow chart including various methods for analyzing data.

Figures 21-46 depict exemplary probe sets described herein.

50 Figures 47 and 48 show the resulting fluorescence patterns when products contain unique affinity tag sequences and the underlying substrate contains complements to each of the unique affinity tags within the same location (e.g., as the same member) on a substrate.

Figures 49 and 51 show the resulting fluorescence patterns when different products contain identical affinity tag sequences and the underlying substrate contains the complement to the affinity tag.

55 Figures 50 and 52 show zoomed-in locations of Figures 49 and 51, respectively.

Figures 53 and 54 show the resulting fluorescence patterns when products contain unique affinity tag sequences and the underlying substrate has one location (e.g., as one member) containing the complement to one affinity tag

complement, and another separate location (e.g., as another member) containing the complement to the other affinity tag.

5 Figure 55 depicts two probe sets; one probe set for Locus 1 and one probe set for Locus 2 - although as aforementioned, multiple probes sets may be designed for each genomic locus.

Figure 56 depicts the procedural workflow that would be applied to the collection of probe sets.

10 Figure 57 depicts a modified version of the procedural workflow illustrated in Figure 56.

Figure 58 provides an example of how probe products for Locus 1 and Locus 2 may be labeled with different label molecules.

15 Figure 59 provides evidence that probe products representing a multitude of genomic locations for one locus may be generated in a ligase enzyme specific manner using the hybridization-ligation process.

Figure 60 provides data indicating that probe sets may be used to detect relative changes in copy number state.

20 Figure 61 provides evidence that mixtures of probe products may be used to generate quantitative microarray data.

Figures 62-64 illustrate modifications of the general procedure described in Figures 55 to 58.

Figure 65 depicts a further embodiment of the modified procedure described in Figure 62.

25 Figure 66 depicts yet another embodiment of the procedure depicted in Figure 65.

Figure 67 depicts exemplary probe sets used in methods described herein.

30 Figure 68 depicts exemplary probe sets used in methods described herein when translocations that have known breakpoints are assayed.

Figure 69 depicts exemplary probe sets used in methods described herein when mutations at SNPs are targeted.

#### Detailed Description of the Invention

35 **[0004]** The methods described herein may employ, unless otherwise indicated, conventional techniques and descriptions of molecular biology (including recombinant techniques), cell biology, biochemistry, and microarray and sequencing technology, which are within the skill of those who practice in the art. Such conventional techniques include polymer array synthesis, hybridization and ligation of oligonucleotides, sequencing of oligonucleotides, and detection of hybrid-  
40 ization using a label. Specific illustrations of suitable techniques can be had by reference to the examples herein. However, equivalent conventional procedures can, of course, also be used. Such conventional techniques and descriptions can be found, for example, in Kimmel and Oliver, DNA Microarrays (2006) Elsevier; Campbell, DNA Microarray, Synthesis and Synthetic DNA (2012) Nova Science; Bowtell and Sambrook, DNA Microarrays: Molecular Cloning Manual (2003) Cold Spring Harbor Laboratory Press. Before the present compositions, research tools and methods are described,  
45 it is to be understood that this invention is not limited to the specific methods, compositions, targets and uses described, as such may, of course, vary. It is also to be understood that the terminology used herein is for the purpose of describing particular aspects only and is not intended to limit the scope of the present invention, which will be limited only by appended claims.

50 **[0005]** The present invention is defined in independent claim 1 and certain optional features thereof are defined in the dependent claims. In so far as the terms "invention", "example", "aspect", and "embodiment" are used herein, this will be interpreted in such a way that the only protection sought is for the invention as claimed.

55 **[0006]** The invention relates to methods of detecting a genetic variation in a genetic sample from a subject. The genetic variation herein may include, but is not limited to, one or more substitution, inversion, insertion, deletion, or mutation in nucleotide sequences (e.g., DNA and RNA) and proteins (e.g., peptide and protein), one or more rare allele, polymorphism, single nucleotide polymorphism (SNP), large-scale genetic polymorphism, such as inversions and translocations, differences in the abundance and/or copy number (e.g., copy number variants, CNVs) of one or more nucleotide molecules (e.g., DNA), trisomy, monosomy, and genomic rearrangements. In some embodiments, the genetic variation may be related to metastasis, presence, absence, and/or risk of a disease, such as cancer, pharmacokinetic variability, drug

toxicity, adverse events, recurrence, and/or presence, absence, or risk of organ transplant rejection in the subject. For example, copy number changes in the *HER2* gene affect whether a breast cancer patient will respond to Herceptin treatment or not. Similarly, detecting an increase in copy number of chromosome 21 (or 18, or 13, or sex chromosomes) in blood from a pregnant woman may be used to as a non-invasive diagnostic for Down's Syndrome in an unborn child.

5 An additional example is the detection of alleles from a transplanted organ that are not present in the recipient genome - monitoring the frequency, or copy number, of these alleles may identify signs of potential organ rejection. Various methods may be used to detect such changes (e.g., rtPCR, sequencing and microarrays). One of the methods is to count individual, labeled molecules to either detect the presence of a mutation (e.g., EGFR mutation in cancer) or an excess of a specific genomic sequence or region (e.g., Chromosome 21 in Down's Syndrome). Counting single molecules

10 may be done in a number of ways, with a common readout being to deposit the molecules on a surface and image. **[0007]** Moreover, the genetic variation may be de novo genetic mutations, such as single- or multi-base mutations, translocations, subchromosomal amplifications and deletions, and aneuploidy. In some embodiments, the genetic variation may mean an alternative nucleotide sequence at a genetic locus that may be present in a population of individuals and that includes nucleotide substitutions, insertions, and deletions with respect to other members of the population. In

15 additional embodiments, the genetic variation may be aneuploidy. In yet additional embodiments, the genetic variation may be trisomy 13, trisomy 18, trisomy 21, aneuploidy of X (e.g., trisomy XXX and trisomy XXY), or aneuploidy of Y (e.g., trisomy YYY). In further embodiments, the genetic variation may be in region 22q11.2, 1q21.1, 9q34, 1p36, 4p, 5p, 7q11.23, 11q24.1, 17p, 11p15, 18q, or 22q13. In further embodiments, the genetic variation may be a microdeletion or microamplification.

20 **[0008]** In some embodiments, detecting, discovering, determining, measuring, evaluating, counting, and assessing the genetic variation are used interchangeably and include quantitative and/or qualitative determinations, including, for example, identifying the genetic variation, determining presence and/or absence of the genetic variation, and quantifying the genetic variation. In further embodiments, the methods of the present disclosure may detect multiple genetic variations. The term "and/or" used herein is defined to indicate any combination of the components. Moreover, the singular forms

25 "a," "an," and "the" may further include plural referents unless the context clearly dictates otherwise. Thus, for example, reference to "a nucleotide region" refers to one, more than one, or mixtures of such regions, and reference to "an assay" may include reference to equivalent steps and methods known to those skilled in the art, and so forth.

**[0009]** "Sample" means a quantity of material from a biological, environmental, medical, or patient source in which detection, measurement, or labeling of target nucleic acids, peptides, and/or proteins is sought. On the one hand it is meant to include a specimen or culture (e.g., microbiological cultures). On the other hand, it is meant to include both biological and environmental samples. A sample may include a specimen of synthetic origin. Environmental samples include environmental material, such as surface matter, soil, water and industrial samples, as well as samples obtained from food and dairy processing instruments, apparatus, equipment, utensils, disposable and non-disposable items. "Genetic sample" may be any liquid or solid sample with heritable and/or non-heritable biological information coded in

30 the nucleotide sequences of nucleic acids. The sample may be obtained from a source, including, but not limited to, whole blood, serum, plasma, urine, saliva, sweat, fecal matter, tears, intestinal fluid, mucous membrane samples, lung tissue, tumors, transplanted organs, fetus, and/or other sources. Genetic samples may be from an animal, including human, fluid, solid (e.g., stool) or tissue. Genetic samples may include materials taken from a patient including, but not limited to cultures, blood, saliva, cerebral spinal fluid, pleural fluid, milk, lymph, sputum, semen, needle aspirates, and the like. Moreover, the genetic sample may be a fetal genetic material from a maternal blood sample. The fetal genetic material may be isolated and separated from the maternal blood sample. The genetic sample may be a mixture of fetal and maternal genetic material. In addition, the genetic sample may include aberrant genetic sequences arising from tumor formation or metastasis, and/or donor DNA signatures present in a transplant recipient. In additional embodiments, when the genetic sample is plasma, the method may comprise isolating the plasma from a blood sample of the subject.

35 In further embodiments, when genetic sample is serum, the method may comprise isolating the serum from a blood sample of the subject. In yet additional embodiments, when the genetic sample is a cell free DNA (cfDNA) sample, the method further comprises isolating the cell free DNA sample from a sample obtained from the source described herein. The cell free DNA sample herein means a population of DNA molecules circulating freely in the bloodstream, outside of any cell or organelle. In the case of a pregnancy, cell free DNA from the mother carries a mixture of both maternal DNA as well as fetal DNA. These examples are not to be construed as limiting the sample types applicable to the present invention.

40 **[0010]** In some embodiments, the method of the present disclosure may comprise selecting and/or isolating genetic locus or loci of interest, and quantifying the amount of each locus present (for example for determining copy number) and/or the relative amounts of different locus variants (for example two alleles of a given DNA sequence). Region, region of interest, locus, or locus of interest in reference to a genome or target polynucleotide used herein means a contiguous sub-region or segment of the genome or target polynucleotide. As used herein, region, regions or interest, locus, locus, or locus of interest in a nucleotide molecule may refer to the position of a nucleotide, a gene or a portion of a gene in a genome, including mitochondrial DNA or other non-chromosomal DNA, or it may refer to any contiguous portion of

genomic sequence whether or not it is within, or associated with, a gene. A region, region of interest, locus, locus, or locus of interest in a nucleotide molecule may be from a single nucleotide to a segment of a few hundred or a few thousand nucleotides in length or more. In some embodiments, a region or locus of interest may have a reference sequence associated with it. "Reference sequence" used herein denotes a sequence to which a locus of interest in a nucleic acid is being compared. In certain embodiments, a reference sequence is considered a "wild type" sequence for a locus of interest. A nucleic acid that contains a locus of interest having a sequence that varies from a reference sequence for the locus of interest is sometimes referred to as "polymorphic" or "mutant" or "genetic variation." A nucleic acid that contains a locus of interest having a sequence that does not vary from a reference sequence for the locus of interest is sometimes referred to as "non-polymorphic" or "wild type" or "non-genetic variation." In certain embodiments, a locus of interest may have more than one distinct reference sequence associated with it (e.g., where a locus of interest is known to have a polymorphism that is to be considered a normal or wild type). In some embodiments, the method of the present disclosure may also comprise electing and/or isolating peptide or peptides of interest, and qualifying the amount of each peptide present and/or relative amounts of different peptides.

**[0011]** In additional embodiments, the region of interest described herein may include "consensus genetic variant sequence" which refers to the nucleic acid or protein sequence, the nucleic or amino acids of which are known to occur with high frequency in a population of individuals who carry the gene which codes for a protein not functioning normally, or in which the nucleic acid itself does not function normally. Moreover, the region of interest described herein may include "consensus normal gene sequence" which refers to a nucleic acid sequence, the nucleic acid of which are known to occur at their respective positions with high frequency in a population of individuals who carry the gene which codes for a protein not functioning normally, or which itself does not function normally. In further embodiments, the control region that is not the region of interest or the reference sequence described herein may include "consensus normal sequence" which refers to the nucleic acid or protein sequence, the nucleic or amino acids of which are known to occur with high frequency in a population of individuals who carry the gene which codes for a normally functioning protein, or in which the nucleic acid itself has normal function.

**[0012]** The methods described herein may produce highly accurate measurements of genetic variation. One type of variation described herein includes the relative abundance of two or more distinct genomic loci. In this case, the loci may be small (e.g., as small as about 300, 250, 200, 150, 100, or 50 nucleotides or less), moderate in size (e.g., from 1,000, 10,000, 100,000 or one million nucleotides), and as large as a portion of a chromosome arm or the entire chromosome or sets of chromosomes. The results of this method may determine the abundance of one locus to another. The precision and accuracy of the methods of the present disclosure may enable the detection of very small changes in copy number (as low as about 25, 10, 5, 4, 3, 2, 1, 0.5, 0.1, 0.05, 0.02 or 0.01 % or less), which enables identification of a very dilute signature of genetic variation. For Example, a signature of fetal aneuploidy may be found in a maternal blood sample where the fetal genetic aberration is diluted by the maternal blood, and an observable copy number of change of about 2% is indicative of fetal trisomy.

**[0013]** As used herein, the term "about" means modifying, for example, lengths of nucleotide sequences, degrees of errors, dimensions, the quantity of an ingredient in a composition, concentrations, volumes, process temperature, process time, yields, flow rates, pressures, and like values, and ranges thereof, refers to variation in the numerical quantity that may occur, for example, through typical measuring and handling procedures used for making compounds, compositions, concentrates or use formulations; through inadvertent error in these procedures; through differences in the manufacture, source, or purity of starting materials or ingredients used to carry out the methods; and like considerations. The term "about" also encompasses amounts that differ due to aging of, for example, a composition, formulation, or cell culture with a particular initial concentration or mixture, and amounts that differ due to mixing or processing a composition or formulation with a particular initial concentration or mixture. Whether modified by the term "about" the claims appended hereto include equivalents to these quantities. The term "about" further may refer to a range of values that are similar to the stated reference value. In certain embodiments, the term "about" refers to a range of values that fall within 50, 25, 10, 9, 8, 7, 6, 5, 4, 3, 2, 1 percent or less of the stated reference value.

**[0014]** In some embodiments, the subject may be a pregnant subject, human, a subject with a high risk of a genetic disease (e.g., cancer), all of the various families of domestic animals, as well as feral or wild animals. In some embodiments, the genetic variation may be a genetic variation in the fetus of the pregnant subject (e.g., copy number variants and aneuploidy in the fetus). In some embodiments, the subject is a pregnant subject, and the genetic variation is a variation in the fetus of the pregnant subject in a region selected from the group consisting of 22q11.2, 1q21.1, 9q34, 1p36, 4p, 5p, 7q11.23, 11q24.1, 17p, 11p15, 18q, and 22q13, (e.g., a mutation and/or copy number change in any of regions 22q11.2, 1q21.1, 9q34, 1p36, 4p, 5p, 7q11.23, 11q24.1, 17p, 11p15, 18q, and 22q13). Fetus described herein means an unborn offspring of a human or other animal. In some embodiments, the fetus may be the offspring more than 1, 2, 3, 4, 5, 6, 7, 8, 9, 10, 11, 12, 13, 14, 15, 16, 17, 18, 19, 20 weeks after conception. In additional embodiments, the fetus may be an offspring conceived by implants, in vitro fertilization, multiple pregnancies, or twinning. In additional embodiments, the fetus may be part of a pair of twins (identical or non-identical), or a trio of triplets (identical or non-identical)

**[0015]** The inventions according to some embodiments encompass at least two major components: an assay for the selective identification of genomic loci, and a technology for quantifying these loci with high accuracy. The assay may include methods of selectively labeling and/or isolating one or more nucleic acid sequences, in such a manner that the labeling step itself is sufficient to yield molecules (defined as "probe products," "ligated probe set," "conjugated probe set," "ligated probes," "conjugated probes," or "labeled molecules" in this invention) containing all necessary information for identification of a particular sequence in the context of a particular assay. For example, the assay may comprise contacting, binding, and/or hybridizing probes to a sample, ligating and/or conjugating the probes, optionally amplifying the ligated/conjugated probes, and immobilizing the probes to a substrate. In some embodiments, the assays and methods described herein may be performed on a single input sample in parallel as a multiplex assay as described herein

**[0016]** The probe product, ligated probe set, conjugated probe set, ligated probes, conjugated probes, and labeled molecules may be single, contiguous molecule resulting from the performance of enzymatic action on a probe set, such as an assay. In a probe product or a labeled molecule, one or more individual probes from a probe set may be covalently modified such that they form a singular distinct molecular species as compared to either probes or probe sets. As a result, probe products or a labeled molecule may be chemically distinct and may therefore be identified, counted, isolated, or further manipulated apart from probes or probe sets.

**[0017]** For example, probe products may contain one or more identification labels, and one or more affinity tags for isolation and/or immobilization. In some embodiments, no additional modifications of probe products (e.g., DNA sequence determination) need to be performed. In some embodiments, no additional interrogations of the DNA sequence are required. The probe products containing the labels may be directly counted, typically after an immobilization step onto a solid substrate. For example, organic fluorophore labels are used to label probe products, and the probe products are directly counted by immobilizing the probe products to a glass substrate and subsequent imaging via a fluorescent microscope and a digital camera. In other embodiments, the label may be selectively quenched or removed depending on whether the labeled molecule has interacted with its complementary genomic locus. In additional embodiments, two labels on opposite portions of the probe product may work in concert to deliver a fluorescence resonance energy transfer (FRET) signal depending on whether the labeled molecule has interacted with its complementary genomic locus. For a given genomic locus, labeling probes containing the labels be designed for any sequence region within that locus. A set of multiple labeling probes with same or different labels may also be designed for a single genomic locus. In this case, a probe may selectively isolate and label a different region within a particular locus, or overlapping regions within a locus. In some embodiments, the probe products containing affinity tags are immobilized onto the substrate via the affinity tags. For example, affinity tags are used to immobilize probe products onto the substrate, and the probe products containing the affinity tags are directly counted. For a given genomic locus, tagging probes containing the affinity tags be designed for any sequence region within that locus. A set of multiple tagging probes with same or different affinity tags may also be designed for a single genomic locus. In this case, a probe may selectively isolate and tag a different region within a particular locus, or overlapping regions within a locus.

**[0018]** In one aspect, the methods of the present disclosure may comprise contacting probe sets described herein with the genetic sample described herein. In some embodiments, the methods of the present disclosure may comprise contacting multiple probe sets, such as first and second probe sets, to the genetic sample. In additional embodiments, each of the probe sets comprises a labeling probe and a tagging probe. For example, the first probe set comprises a first labeling probe and a first tagging probe, and the second probe set comprises a second labeling probe and a second tagging probe.

**[0019]** Contacting the probe sets to the genetic sample may be performed simultaneously or after hybridizing, ligating, amplifying and/or immobilizing the probes. Moreover, contacting the probe sets to the genetic sample may be performed simultaneously or before hybridizing, ligating, amplifying, and/or immobilizing the probes.

**[0020]** For a given genomic locus or region of a nucleotide molecule in the genetic sample, a single nucleic acid sequence within that locus, or multiple nucleic acid sequences within that locus may be interrogated and/or quantified via the creation of probe products. The interrogated sequences within a genomic locus may be distinct and/or overlapping, and may or may not contain genetic polymorphisms. A probe product is formed by the design of one or more oligonucleotides called a "probe set." For example, the probe product may be formed by ligating the probe set by ligating the probes in the probe set. A probe set comprises at least one probe that hybridize, conjugate, bind, or immobilize to a target molecule, including nucleic acids (e.g., DNA and RNA), peptides, and proteins. In some embodiments, a probe may comprise an isolated, purified, naturally-occurring, non-naturally occurring, and/or artificial material, for example, including oligonucleotides of any length (e.g., 5, 10, 20, 30, 40, 50, 100, or 150 nucleotides or less), in which at least a portion(s) (e.g., 50, 60, 70, 80, 85, 90, 91, 92, 93, 94, 95, 96, 97, 98, 99, or 100%) of the oligonucleotide sequences is complementary to a sequence motif and/or hybridization domain present in one or more target molecules, such that the probe is configured to hybridize (or interact in a similar manner) in part or in total to one or more target molecules or nucleic acid region of interest. The part of the target molecule or the nucleic acid region of interest to which a probe hybridizes is called the probe's "hybridization domain," which may be in part or in total of the target molecule or the nucleic acid region of interest as described herein.

[0021] A probe may be single-stranded or double-stranded. In some embodiments, the probe may be prepared from a purified restriction digest or produced synthetically, recombinantly or by PCR amplification. In additional embodiments, the probe may comprise a material that binds to a particular peptide sequence. A probe set described herein may comprise a set of one or more probes designed to correspond to a single genomic location or a peptide in a protein sequence.

[0022] "Nucleotide" used herein means either a deoxyribonucleotide or a ribonucleotide or any nucleotide analogue (e.g., DNA and RNA). Nucleotide analogues include nucleotides having modifications in the chemical structure of the base, sugar and/or phosphate, including, but not limited to, 5'-position pyrimidine modifications, 8-position purine modifications, modifications at cytosine exocyclic amines, substitution of 5-bromo-uracil, and the like; and 2'-position sugar modifications, including but not limited to, sugar-modified ribonucleotides in which the 2'-OH is replaced by a group selected from H, OR, R, halo, SH, SR, NH<sub>2</sub>, NHR, NR<sub>2</sub>, or CN. shRNAs also may comprise non-natural elements such as non-natural nucleotides, e.g., inosin and xanthine, non-natural sugars, e.g., 2'-methoxy ribose, or non-natural phosphodiester linkages, e.g., methylphosphonates, phosphorothioates and peptides. In one embodiment, the shRNA further comprises an element or a modification that renders the shRNA resistant to nuclease digestion. "Polynucleotide" or "oligonucleotide" is used interchangeably and each means a linear polymer of nucleotide monomers. Monomers making up polynucleotides and oligonucleotides are capable of specifically binding to a natural and/or artificial polynucleotide by way of a regular pattern of monomer-to-monomer interactions, such as Watson-Crick type of base pairing, base stacking, Hoogsteen or reverse Hoogsteen types of base pairing, or the like. Such monomers and their internucleosidic linkages may be naturally occurring or may be analogues thereof, e.g., naturally occurring or non-naturally occurring analogues. Non-naturally occurring analogues may include PNAs, LNAs, phosphorothioate internucleosidic linkages, nucleotides containing linking groups permitting the attachment of labels, such as fluorophores, or haptens, and the like. Whenever the use of an oligonucleotide or polynucleotide requires enzymatic processing, such as extension by a polymerase, ligation by a ligase, or the like, one of ordinary skill would understand that oligonucleotides or polynucleotides in those instances would not contain certain analogues of internucleosidic linkages, sugar moieties, or nucleotides at any or some positions. Polynucleotides typically range in size from a few monomeric units when they are referred to as "oligonucleotides" to several thousand monomeric units. Whenever a polynucleotide or oligonucleotide is represented by a sequence of letters (upper or lower case), such as "ATGCCTG," it will be understood that the nucleotides are in 5'→3' order from left to right. Usually polynucleotides comprise the four natural nucleosides (e.g., deoxyadenosine, deoxycytidine, deoxyguanosine, deoxythymidine for DNA or their ribose counterparts for RNA) linked by phosphodiester linkages; however, they may also comprise non-natural nucleotide analogues, e.g., including modified nucleotides, sugars, or internucleosidic linkages. It is clear to those skilled in the art that where an enzyme has specific oligonucleotide or polynucleotide substrate requirements for activity, e.g., single stranded DNA, RNA, RNA/DNA duplex, or the like, then selection of appropriate composition for the oligonucleotide or polynucleotide substrates is well within the knowledge of one of ordinary skill.

[0023] In another aspect, the methods of the present disclosure may comprise hybridizing at least parts of the first and second probe sets to first and second nucleic acid regions of interest in nucleotide molecules of the genetic sample, respectively. The hybridization of the probes to the nucleic acid of interest may be performed simultaneously or after contacting the probes to the genetic sample, ligating, amplifying and/or immobilizing the probes. Moreover, the hybridization of the probes to the nucleic acid of interest may be performed simultaneously or before ligating, amplifying, and/or immobilizing the probes. A part or full part of the probe may hybridize to a part or full part of the region of interest in single or double stranded nucleotide molecules, protein, or antibody in a sample. The region of interest hybridized to the probe may be from 1 to 50 nucleotides, 50 to 1000 nucleotides, 100 to 500 nucleotides, 5, 10, 50, 100, 200 nucleotides or less, or 2, 5, 10, 50, 100, 200, 500, 1000 nucleotides or more. Probes may be designed or configured to hybridize perfectly with a target region or molecule, or they may be designed such that a single-base mismatch (e.g., at a single nucleotide polymorphism, or SNP site), or a small number of such mismatches, fails to yield a hybrid of probe and target molecule.

[0024] In additional embodiments, the first labeling probe and/or the first tagging probe are hybridized to the first nucleic acid region of interest, and the second labeling probe and/or the second tagging probes are hybridized to the second nucleic acid region of interest. In additional embodiments, multiple or all probes and/or other components (e.g., labelling probes, tagging probes, and gap probes) of a probe set that are hybridized to a nucleic acid region of interest are adjacent to each other. When two of the probes and/or components hybridized to the nucleic acid region of interest are "adjacent" or "immediately adjacent," there is no nucleotide between the hybridization domains of the two probes in the nucleic acid region of interest. In this embodiment, the different probes within a probe set may be covalently ligated together to form a larger oligonucleotide molecule. In another embodiment, a probe set may be designed to hybridize to a non-contiguous, but proximal, portion of the nucleic acid region of interest, such that there is a "gap" of one or more nucleotides on the nucleic acid region of interest, in between hybridized probes from a probe set, that is not occupied by a probe. In this embodiment, a DNA polymerase or another enzyme may be used to synthesize a new polynucleotide sequence, in some cases covalently joining two probes from a single probe set. Within a probe set, any probe may bear

one or more labels, or affinity tags used for either locus identification or isolation. In one aspect, the first and second labeling probes are hybridized to the first and second nucleic acid regions of interest in nucleotide molecules of the genetic sample, respectively; the first and second tagging probes are hybridized to the first and second nucleic acid regions of interest in nucleotide molecules of the genetic sample, respectively; the first labeling probe is hybridized to a region adjacent to where the first tagging probe is hybridized; and the second labeling probe is hybridized to a region adjacent to where the second tagging probe is hybridized.

**[0025]** The hybridization occurs in such a manner that the probes within a probe set may be modified to form a new, larger molecular entity (e.g., a probe product). The probes herein may hybridize to the nucleic acid regions of interest under stringent conditions. As used herein the term "stringency" is used in reference to the conditions of temperature, ionic strength, and the presence of other compounds such as organic solvents, under which nucleic acid hybridizations are conducted. "Stringency" typically occurs in a range from about  $T_m$  ° C to about 20° C to 25° C below  $T_m$ . A stringent hybridization may be used to isolate and detect identical polynucleotide sequences or to isolate and detect similar or related polynucleotide sequences. Under "stringent conditions" the nucleotide sequence, in its entirety or portions thereof, will hybridize to its exact complement and closely related sequences. Low stringency conditions comprise conditions equivalent to binding or hybridization at 68° C. in a solution consisting of 5×SSPE (43.8 g/l NaCl, 6.9 g/l  $\text{NaH}_2\text{PO}_4 \cdot \text{H}_2\text{O}$  and 1.85 g/l EDTA, pH adjusted to 7.4 with NaOH), 0.1% SDS, 5× Denhardt's reagent (50× Denhardt's contains per 500 ml: 5 g Ficoll (Type 400), 5 g BSA) and 100 µg/ml denatured salmon sperm DNA followed by washing in a solution comprising 2.0×SSPE, 0.1% SDS at room temperature when a probe of about 100 to about 1000 nucleotides in length is employed. It is well known in the art that numerous equivalent conditions may be employed to comprise low stringency conditions; factors such as the length and nature (DNA, RNA, base composition) of the probe and nature of the target (DNA, RNA, base composition, present in solution or immobilized, etc.) and the concentration of the salts and other components (e.g., the presence or absence of formamide, dextran sulfate, polyethylene glycol), as well as components of the hybridization solution may be varied to generate conditions of low stringency hybridization different from, but equivalent to, the above listed conditions. In addition, conditions which promote hybridization under conditions of high stringency (e.g., increasing the temperature of the hybridization and/or wash steps, the use of formamide in the hybridization solution, etc.) are well known in the art. High stringency conditions, when used in reference to nucleic acid hybridization, comprise conditions equivalent to binding or hybridization at 68° C in a solution consisting of 5×SSPE, 1% SDS, 5× Denhardt's reagent and 100 µg/ml denatured salmon sperm DNA followed by washing in a solution comprising 0.1×SSPE and 0.1% SDS at 68° C when a probe of about 100 to about 1000 nucleotides in length is employed.

**[0026]** In some embodiments, the probe product may be formed only if the probes within a probe set are correctly hybridized. Therefore, the probe products may be formed with high stringency and high accuracy. Again, the probe products may contain sufficient information for identifying the genomic sequence for which the probe product was designed to interrogate. Therefore, generation and direct quantification of a particular probe product (in this case, by molecular counting) may reflect the abundance of a particular genetic sequence in the originating sample.

**[0027]** In additional embodiments, the nucleic acid regions of interest, to which the probes are configured to hybridize to, are located in different chromosomes. For example, the first nucleic acid region of interest is located in chromosome 21, and the second nucleic acid region of interest is not located in chromosome 21 (e.g., located in chromosome 18).

**[0028]** In another aspect, the methods of the present disclosure may comprise ligating the first labeling probe and the first tagging probe, and ligating the second labeling probe and the second tagging probe. The ligation of the probes may be performed simultaneously or after contacting the probes to the genetic sample, amplifying and/or immobilizing the probes. Moreover, the ligation of the probes may be performed simultaneously or before contacting the probes to the genetic sample, amplifying, and/or immobilizing the probes. The ligation herein means the process of joining two probes (e.g., joining two nucleotide molecules) together. For example, ligation herein may involve the formation of a 3',5'-phosphodiester bond that links two nucleotides, and a joining agent that is an agent capable of causing ligation may be an enzyme or a chemical.

**[0029]** In another aspect, the methods of the present disclosure may comprise amplifying the ligated probes and/or ligated probe sets. The amplification of the ligated probes may be performed simultaneously or after contacting the probes to the genetic sample, ligating, hybridizing and/or immobilizing the probes. Moreover, the amplification of the ligated probes may be performed simultaneously or before immobilizing the probes. Amplification herein is defined as the production of additional copies of the probe and/or probe product and may be carried out using polymerase chain reaction technologies well known in the art. As used herein, the term "polymerase chain reaction" ("PCR") refers to a method for increasing the concentration of a segment of a target sequence (e.g., in a mixture of genomic DNA) without cloning or purification. The length of the amplified segment of the desired target sequence is determined by the relative positions of two oligonucleotide primers with respect to each other, and therefore, this length is a controllable parameter. By virtue of the repeating aspect of the process, the method is referred to as the "polymerase chain reaction" (hereinafter "PCR"). Because the desired amplified segments of the target sequence become the predominant sequences (in terms of concentration) in the mixture, they are said to be "PCR amplified." With PCR, it is possible to amplify a single copy of a specific target sequence in genomic DNA to a level detectable by several different methodologies (e.g., hybridization

with a labeled probe). In addition to genomic DNA, any oligonucleotide sequence may be amplified with the appropriate set of primer molecules. In particular, the amplified segments created by the PCR process itself are, themselves, efficient templates for subsequent PCR amplifications. An amplification may be a "real-time" amplification if a detection chemistry is available that permits a reaction product to be measured as the amplification reaction progresses, e.g., "real-time PCR," or "real-time NASBA" as described in Leone et al, *Nucleic Acids Research*, 26: 2150-2155 (1998).

**[0030]** Primers are usually single-stranded for maximum efficiency in amplification, but may alternatively be double-stranded. If double-stranded, the primer is usually first treated to separate its strands before being used to prepare extension products. This denaturation step is typically influenced by heat, but may alternatively be carried out using alkali, followed by neutralization. Thus, a "primer" is complementary to a template, and complexes by hydrogen bonding or hybridization with the template to give a primer/template complex for initiation of synthesis by a polymerase, which is extended by the addition of covalently bonded nucleotides linked at its 3' end complementary to the template in the process of DNA synthesis.

**[0031]** A "primer pair" as used herein refers to a forward primer and a corresponding reverse primer, having nucleic acid sequences suitable for nucleic acid-based amplification of a target nucleic acid. Such primer pairs generally include a first primer having a sequence that is the same or similar to that of a first portion of a target nucleic acid, and a second primer having a sequence that is complementary to a second portion of a target nucleic acid to provide for amplification of the target nucleic acid or a fragment thereof. Reference to "first" and "second" primers herein is arbitrary, unless specifically indicated otherwise. For example, the first primer may be designed as a "forward primer" (which initiates nucleic acid synthesis from a 5'-end of the target nucleic acid) or as a "reverse primer" (which initiates nucleic acid synthesis from a 5'-end of the extension product produced from synthesis initiated from the forward primer). Likewise, the second primer may be designed as a forward primer or a reverse primer.

**[0032]** In some embodiments, the nucleic acid region of interest in the nucleotide molecule herein may be amplified by the amplification methods described herein. The nucleic acids in a sample may or may not be amplified prior to analysis, using a universal amplification method (e.g., whole genome amplification and whole genome PCR). The amplification of the nucleic acid region of interest may be performed simultaneously or after contacting the probes to the genetic sample, ligating, amplifying and/or immobilizing the probes. Moreover, the amplification of the ligated probes may be performed simultaneously or before contacting the probes to the genetic sample, ligating the probes, immobilizing the probes, and/or counting the labels.

**[0033]** In additional embodiments, the method excludes amplification of the nucleotide molecules of the genetic sample after the hybridization or the ligation. In further embodiments, the method excludes amplification of the nucleotide molecules of the genetic sample after the hybridization and the ligation.

**[0034]** In another aspect, the methods of the present disclosure may comprise immobilizing the tagging probes to a predetermined location on a substrate. The immobilization of the probe to a substrate may be performed simultaneously or after contacting the probes to the genetic sample, hybridizing the probes to the nucleic acid region of interest, ligating and/or amplifying the probes. Moreover, the immobilization of the probe to a substrate may be performed simultaneously or before contacting the probes to the genetic sample, hybridizing the probes to the nucleic acid region of interest, ligating, amplifying and/or counting the probes. Immobilization herein means directly or indirectly binding the tagging probes to the pre-determined location on the substrate by a physical or chemical bond. In some embodiments, the substrate herein may comprise a binding partner that is configured to contact and bind to a part or full tag in the tagging probe described herein and immobilize the tag and thus the tagging probe comprising the tag. The tag of the tagging probe may comprise a corresponding binding partner of the binding partner on the substrate as described herein.

**[0035]** Immobilization may be performed by hybridizing a part or full tagging probe to a part or full binding partner on the substrate. For example, the immobilizing step comprises hybridizing at least a part of the tag or tagging nucleotide sequence to a corresponding nucleotide molecule immobilized on the substrate. Here, the corresponding nucleotide molecule is a binding partner of the tag or tagging nucleotide sequence that is configured to hybridize partially or fully to the tag or tagging nucleotide sequence. In some embodiments, the oligonucleotide or polynucleotide binding partners may be single stranded and may be covalently attached to the substrate, for example, by 5'-end or a 3'-end. Immobilization may also be performed by the following exemplary binding partners and binding means: Biotin-oligonucleotide complexed with Avidin, Streptavidin or Neutravidin; SH-oligonucleotide covalently linked via a disulphide bond to a SH-surface; Amine-oligonucleotide covalently linked to an activated carboxylate or an aldehyde group; Phenylboronic acid (PBA)-oligonucleotide complexed with salicylhydroxamic acid (SHA); Acrydite-oligonucleotide reacted with thiol or silane surface or co-polymerized with acrylamide monomer to form polyacrylamide, or by other methods known in the art. For some applications where it is preferable to have a charged surface, surface layers may be composed of a polyelectrolyte multilayer (PEM) structure as shown in U.S. Patent Application Publication No. 2002/025529. In some embodiments, the immobilization may be performed by well-known procedures, for example, comprising contacting the probes with the support having binding partners attached for a certain period of time, and after the probes are depleted for the extension, the support with the immobilized extension products is optionally rinsed using a suitable liquid. In additional embodiments, immobilizing probe products onto a substrate may allow for rigorous washing for removing components

from the biological sample and the assay, thus reducing background noise and improving accuracy.

**[0036]** "Solid support," "support," "substrate," and "solid phase support" are used interchangeably and refer to a material or group of materials having a rigid or semi-rigid surface or surfaces. In some embodiments, at least one surface of the substrate will be substantially flat, although in some embodiments it may be desirable to physically separate synthesis regions for different compounds with, for example, wells, raised regions, pins, etched trenches, or the like. In additional embodiments, the substrate may comprise at least one planar solid phase support (e.g., a glass microscope slide). According to other embodiments, the substrate(s) will take the form of beads, resins, gels, microspheres, or other geometric configurations. In one aspect, the substrate according to some embodiments of the present disclosure excludes beads, resins, gels, and/or microspheres.

**[0037]** In some embodiments, as shown in Figure 1, the binding partners, the tags, the affinity tags, labels, the probes (e.g., tagging probes and labeling probes), and/or the probe sets described herein may be immobilized on a substrate (1) as an array (2). The array herein has multiple members (3-10) that may or may not have an overlap (6) between the members. Each member may have at least an area with no overlap with another member (3-5 and 7-10). In additional embodiments, each member may have different shapes (e.g., circular spots (3-8), triangles (9), and squares (10)) and dimensions. A member of an array may have an area about from 1 to  $10^7$  micron<sup>2</sup>, from 100 to  $10^7$  micron<sup>2</sup>, from  $10^3$  to  $10^8$  micron<sup>2</sup>, from  $10^4$  to  $10^7$  micron<sup>2</sup>; from  $10^5$  to  $10^7$  micron<sup>2</sup>; about 0.0001, 0.001, 0.01, 0.1, 1, 10, 100,  $10^3$ ,  $10^4$ ,  $10^5$ ,  $10^6$ ,  $10^7$ ,  $10^8$  or more micron<sup>2</sup>; and/or about 0.001, 0.01, 0.1, 1, 10, 100,  $10^3$ ,  $10^4$ ,  $10^5$ ,  $10^6$ ,  $10^7$ ,  $10^8$  or less micron<sup>2</sup>. An image of an exemplary member (8) according to some embodiments of the present invention is shown as item 12. Moreover, two or more members comprising the binding partners, the tags, the affinity tags, labels, the probes (e.g., tagging probes and labeling probes), and/or the probe sets of the same type may have the same shape and dimension. Specifically, the members of an array comprising the binding partners, tags, affinity tags, labels, tagging probes and/or probe sets configured or used to detect the same genetic variation or a control according to the methods described herein may have the same shapes and dimensions. Further, each and every member of the arrays on the substrate may have the same shapes and dimensions. In other embodiments, the members of an array comprising the binding partners, tags, affinity tags, labels, probes and/or probe sets configured or used to detect different genetic variations and/or controls according to the methods described herein may have the same shapes and dimensions. In addition, each member of the array may comprise different binding partners, the tags, the affinity tags, labels, the probes, and/or the probe sets.

**[0038]** In some embodiments, two members of the array may be separated by (i) a distance, in which there may be no or only very few binding partners, the tags, the affinity tags, labels, the probes (e.g., tagging probes and labeling probes), and/or the probe sets immobilized, and/or (ii) any separator distinguishing one member from the other (e.g., heightened substrate, any material preventing binding of the binding partners, the tags, the affinity tags, the probes (e.g., tagging probes), and/or the probe sets to the substrate, and any non-probe material between the members). In additional embodiments, the members of the array may be distinguished from each other at least by their locations alone. The members of the array may be separated by a distance about from 0 to  $10^4$  microns, from 0 to  $10^3$  microns, from  $10^2$  to  $10^4$  microns, or from  $10^2$  to  $10^3$  microns; about 0, 0.001, 0.1, 1, 2, 3, 4, 5, 10, 50, 100,  $10^3$ ,  $10^4$ ,  $10^5$ ,  $10^6$ ,  $10^7$ , or  $10^8$  microns or more; and/or about 0, 0.001, 0.1, 1, 2, 3, 4, 5, 10, 50, 100,  $10^3$ ,  $10^4$ ,  $10^5$ ,  $10^6$ ,  $10^7$ , or  $10^8$  microns or less. Here, the distance by which two members of the array are separated may be determined by the shortest distance between the edges of the members. For example, in Figure 1, the distance by which two members, items 3 and 4, of an array (2) are separated is the distance indicated by item n. Moreover, for example, the shortest distance by which the members of the array (2) on a substrate (1) are separated is 0, as the distance by which two members, items 10 and 11, of the array are separated. In other embodiments, two members of the array may not be separated and may be overlapped (6). In such embodiments, each member may have at least an area with no overlap with another member (7).

**[0039]** In further embodiments, an array and the members of the array of the binding partners, the tags, the affinity tags, labels, the probes, and/or the probe sets described herein may be located on predetermined locations on the substrate, and the shapes and dimensions of each member of the array and the distance between the members may be predetermined prior to the immobilization. The predetermined location herein means a location that is determined or identified prior to the immobilization. For example, the shape and dimension of each member of an array is determined or identified prior to the immobilization.

**[0040]** In additional embodiments, the substrate may comprise an array of binding partners, each member of the array comprising the binding partners, such as oligonucleotides or polynucleotides, that are immobilized (e.g., by a chemical bond that would be not broken during the hybridization of probes to the binding partners of the substrate described herein) to a spatially defined region or location; that is, the regions or locations are spatially discrete or separated by a defined region or location on the substrate. In further embodiments, the substrate may comprise an array, each member of which comprises binding partners binding to a spatially defined region or location. Each of the spatially defined locations configured to comprise the binding partners may additionally be "addressable" in that its location and the identity of its immobilized binding partners are known or predetermined, for example, prior to its use, analysis, or attaching to their binding partners in tagging probes and/or probe sets. The term "addressable" with respect to the probe sets immobilized

to the substrate means that the nucleotide sequence or other physical and/or chemical characteristics of an end-attached part (e.g., a binding partner of the binding partner of the substrate, tag, affinity tag, and tagging probe) of a probe set described herein may be determined from its address, i.e., a one-to-one correspondence between the sequence or other property of the end-attached part of the probe set and a spatial location on, or characteristic of, the substrate to which the probe set is immobilized. For example, an address of an end-attached part of a probe set is a spatial location, e.g., the planar coordinates of a particular region immobilizing copies of the end-attached part of the probe set. However, end-attached parts of probe sets may be addressed in other ways too, e.g., by color, frequency of micro-transponder, or the like, e.g., Chandler et al, PCT publication WO 97/14028. In further embodiments, the methods described herein exclude "random microarray," which refers to a microarray whose spatially discrete regions of binding partners (e.g., oligonucleotides or polynucleotides) of the substrate and/or the end-attached parts of probe sets are not spatially addressed. That is, the identity of the attached binding partners, tag, affinity tag, tagging probe, and/or probe sets is not discernable, at least initially, from its location. In one aspect, the methods described herein exclude random microarrays that are planar arrays of microbeads.

**[0041]** An array of nucleic acid according to some embodiments of the present disclosure may be produced by any method well known in the art, including but not limited to those described in U.S. Patent Application Publication No. 2013/0172216; Schena, *Microarrays: A Practical Approach* (IRL Press, Oxford, 2000). For example, a DNA capture array may be used. The DNA capture array is a solid substrate (e.g., a glass slide) with localized oligonucleotides covalently attached to the surface. These oligonucleotides may have one or more types on the surface, and may further be segregated geographically across the substrate. Under hybridization conditions, DNA capture arrays will preferentially bind complementary targets compared to other non-specific moieties, thereby acting to both localize targets to the surface and separate them from un-desired species.

**[0042]** In some embodiments, the first and second labeling probes and/or the amplified labeling probes thereof ligated to the immobilized tagging probes comprise first and second labels, respectively.

**[0043]** The labeling probe herein means a probe that comprises or is configured to bind to a label. The labeling probe itself may comprise a label or may be modified to comprise or bind to a label. The amplified probe herein is defined to be the additional copies of an initial probe produced after amplification of the initial probe as described herein. Accordingly, the amplified probes may have a sequence that is the nucleotide sequences of the initial probes and/or complementary sequence of the nucleotide sequences of the initial probes. The amplified probes may contain a sequence that is partial or complete match to the nucleotide sequences of the initial probes. The terms "complementary" or "complementarity" are used in reference to a sequence of nucleotides related by the base-pairing rules. For example, the sequence "5'-CAGT-3'," is complementary to the sequence "5'-ACTG-3'." Complementarity may be "partial" or "total." "Partial" complementarity is where one or more nucleic acid nucleotides in a probe is not matched according to the base pairing rules while others are matched. "Total" or "complete" complementarity between nucleic acids is where each and every nucleic acid base in the probe is matched with another base under the base pairing rules.

**[0044]** Immobilized probe herein is defined to be a probe that is directly or indirectly binding to the substrate by a physical or chemical bond. In some embodiments, a labeling probe may be immobilized to a substrate indirectly via ligation to a tagging probe immobilized to the substrate described herein.

**[0045]** A label herein means an organic, naturally occurring, synthetic, artificial, or non-naturally occurring molecule, dye, or moiety having a property or characteristic that is capable of detection and, optionally, of quantitation. A label may be directly detectable (e.g., radioisotopes, fluorophores, chemiluminophores, enzymes, colloidal particles, fluorescent substances, Quantum dots or other nanoparticles, nanostructures, metal compounds, organometallic labels, and peptide aptamers); or a label may be indirectly detectable using specific binding partners. Examples of the fluorescent substances include fluorescent dyes such as fluorescein, phosphor, rhodamine, polymethine dye derivatives, and the like. Examples of a commercially available fluorescent substance include fluorescent dyes, such as BODYPY FL (trademark, produced by Molecular Probes, Inc.), FluorePrime (product name, produced by Amersham Pharmacia Biotech, Inc.), FluoreDite (product name, produced by Millipore Corporation), FAM (produced by ABI Inc.), Cy 3 and Cy 5 (produced by Amersham pharmacia), TAMRA (produced by Molecular Probes, Inc.), Pacific Blue, TAMRA, Alexa 488, Alexa 594, Alexa 647, Atto 488, Atto 590, Atto 647N and the like. "Quantum dot" (QD) means a nanoscale semiconductor crystalline structure, usually made from cadmium selenide, and absorbs light and then re-emits it a couple of nanoseconds later in a specific color. QDs with a variety of conjugated or reactive surfaces, e.g., amino, carboxyl, streptavidin, protein A, biotin, and immunoglobulins, are also encompassed in the present disclosure.

**[0046]** In additional embodiments, the first and second labels are different so that the labels may be distinguished from each other. In further embodiments, the first and second labels are different in their physical, optical, and/or chemical properties.

**[0047]** In some embodiments, the immobilized labels are optically resolvable. The term "optically resolvable label" or "optically individually resolvable label" herein means a group of labels that may be distinguished from each other by their photonic emission, or other optical properties, for example, after immobilization as described herein. In additional embodiments, even though the labels may have the same optical and/or spectral emission properties, the immobilized

labels may be distinguished from each other spatially. In some embodiments, the labels of the same type, which is defined to be labels having the same optical properties, are immobilized on the substrate, for example as a member of an array described herein, at a density and/or spacing such that the individual probe products are resolvable as shown in item 12 of Figure 1. In this disclosure, the "same labels" are defined to be labels having identical chemical and physical compositions. The "different labels" herein mean labels having different chemical and/or physical compositions, including "labels of different types" having different optical properties. The "different labels of the same type" herein means labels having different chemical and/or physical compositions, but the same optical properties.

**[0048]** Item 12 of Figure 1 depicts an image of an exemplary member of an array comprising immobilized labels. In these embodiments, the labels are spatially addressable as the location of a molecule specifies its identity (and in spatial combinatorial synthesis, the identity is a consequence of location). In additional embodiments, one member of the array on the substrate may have one or multiple labeled probes immobilized to the member. When multiple labeled probes are immobilized to one member of the array, the labels of the same type in the labeled probes immobilized to the one member of an array on the substrate may be distinguished from each other spatially as shown in item 12 of Figure 1. In some embodiments, the immobilized labels of the same type are separated by a distance about from 1 to 1000 nm, from 5 to 100 nm, or from 10 to 100 nm; about 100, 150, 200, 250, 300, 350, or 400 nm or more; and/or about 50, 100, 150, 200, 250, 300, 350, or 400 nm or less in all dimensions. The density of the probe products and their labels on the substrates may be up to many millions (and up to one billion or more) probe products to be counted per substrate. The ability to count large numbers of probe products containing the labels allows for accurate quantification of nucleic acid sequences.

**[0049]** In some embodiments, the immobilized first and second tagging probes and/or the amplified tagging probes thereof comprise first and second tags, respectively. The tagging probe herein means a probe that is configured to directly or indirectly bind to the substrate. The tagging probe itself may bind to the substrate or may be modified to bind to the substrate. A tag or affinity tag herein means a motif for specific isolation, enrichment or immobilization of probe products. Examples of the tag or affinity tag include a binding partner described herein, unique DNA sequences allowing for sequence-specific capture including natural genomic and/or artificial non-genomic sequence, biotin-streptavidin, His-tags, FLAG octapeptide, click chemistry (e.g., pairs of functional groups that rapidly and selectively react with each other under mild, aqueous conditions), and antibodies (e.g., azide-cycline). For example, the immobilizing step comprises hybridizing at least a part of the tag, affinity tag, or tagging nucleotide sequence to a corresponding nucleotide molecule immobilized on the substrate. The tag or affinity tag is configured to bind to entities including, but not limited to a bead, a magnetic bead, a microscope slide, a coverslip, a microarray or a molecule. In some embodiments, the immobilizing step is performed by immobilizing the tags to the predetermined location of the substrate.

**[0050]** In another aspect, the numbers of different labels immobilized on the substrate and thus the numbers of different immobilized probe products comprising the labels are counted. For example, the probe products from each genetic locus are grouped together, and the labels in the immobilized probe products are counted. In some embodiments, multiple sequences within a genomic locus may be interrogated via the creation of multiple probe product types. For this example, different probe products for the same genomic locus may be combined (possibly via immobilization to a common location of a substrate, e.g., as a member of an array described herein), and the labels in these probe products may be directly counted. Different probe products for the same genomic locus may be also separated (possibly via immobilization to different locations of a substrate, e.g., as different members of an array described herein), and the labels in these probe products may be directly counted. In additional embodiments, the substrate may have one or more specific affinity tag in each location on a substrate, e.g., as a member of an array on the substrate. Therefore, another method for quantifying nucleic acid sequences occurs via immobilization of probe products for a single genomic locus (this may be one probe product type, or may be a set of more than one probe product for a particular genomic locus) to the same location of a substrate (e.g., as the same member of an array described herein) as probe products corresponding to a second genomic locus, which may or may not serve as a reference or control locus. In this case, the probe products from the first genomic locus will be distinguishable from the probe products from the second genomic locus, based on the presence of different labels used in generating the probe products.

**[0051]** In one example, for detecting trisomy 21 (aneuploidy) of a fetus through examination of a maternal blood sample, a set of probe products corresponding to chromosome 21 would be generated, for example with a red fluorophore label, and counted. A second set of probe products would also be generated from a reference, or control locus, for example chromosome 18, and counted. This second set of probe products may be generated, for example, with a green fluorophore label.

**[0052]** In some embodiments, these probe products may be prepared such that they are grouped together by locus (in this case chromosome 21 or chromosome 18) and counted separately on a substrate. That is, the probe products corresponding to chromosome 21 may be isolated and counted separately, and the probe products corresponding to chromosome 18 may be isolated and counted separately. In additional embodiments, these probe products may be also prepared in such a way that they are grouped together in the same location of a substrate (e.g., as the same member of an array described herein). In this case, on the same region of a substrate, the probe products bearing a red fluorophore

will correspond to chromosome 21, and the probe products with a green fluorophore will correspond to chromosome 18. For example, since all of these probe products are individually resolvable and may therefore be counted very accurately, an increased frequency of chromosome 21 probe products relative to chromosome 18 probe products (even as small as 0.01, 0.1, one or more percent or less) will signify the presence of trisomy 21 in a fetus. In this case, the probe products for chromosome 18 may serve as a control.

**[0053]** In another aspect, the methods of the present disclosure may comprise counting the labels of the probe sets immobilized to the substrate. In some embodiments, the methods may comprise counting (i) a first number of the first label immobilized to the substrate, and (ii) a second number of the second label immobilized to the substrate. The counting step may be performed after immobilizing the ligated probe set to a substrate, and the substrate with immobilized ligated probe sets may be stored in a condition to prevent degradation of the ligated probe sets (e.g., at room temperature or a temperature below the room temperature) before the counting step is performed.

**[0054]** In order to accurately quantify the relative abundance of different genomic sequences, for example, for quantification of DNA copy number or for quantification of allele frequency, a large number of probe products may be counted. For example, a label may be detected and counted based on measuring, for example, physicochemical, electromagnetic, electrical, optoelectronic or electrochemical properties, or characteristics of the immobilized label.

**[0055]** In some embodiments, the label may be detected by scanning probe microscopy (SPM), scanning tunneling microscopy (STM) and atomic force microscopy (AFM), electron microscopy, optical interrogation/detection techniques including, but not limited to, near-field scanning optical microscopy (NSOM), confocal microscopy and evanescent wave excitation. More specific versions of these techniques include far-field confocal microscopy, two-photon microscopy, wide-field epi-illumination, and total internal reflection (TIR) microscopy. Many of the above techniques may also be used in a spectroscopic mode. The actual detection is by charge coupled device (CCD) cameras and intensified CCDs, photodiodes and/or photomultiplier tubes. In some embodiments, the counting step comprises an optical analysis, detecting an optical property of a label. In additional embodiments, the optical analysis comprises an image analysis as described herein.

**[0056]** In another aspect, the counting step comprises reading the substrate in first and second imaging channels that correspond to the first and second labels, respectively, and producing one or more images of the substrate, wherein the first and second labeling probes are resolvable in the one or more images. In some embodiments, the counting step comprises spatial filtering for image segmentation. In additional embodiments, the counting step comprises watershed analysis, or a hybrid method for image segmentation.

**[0057]** The methods described herein may also look at the frequency of different alleles at the same genetic locus (e.g., two alleles of a given single nucleotide polymorphisms). The accuracy of these methods may detect very small changes in frequency (e.g., as low as about 10, 5, 4, 3, 2, 1, 0.5, 0.1 or 0.01 % or less). As an example, in the case of organ transplantation, a blood sample will contain a very dilute genetic signature from the donated organ. This signature may be the presence of an allele that is not in the recipient of the donated organ's genome. The methods described herein may detect very small deviations in allele frequency (e.g., as low as about 10, 5, 4, 3, 2, 1, 0.5, 0.1 or 0.01 % or less) and may identify the presence of donor DNA in a host sample (e.g., blood sample). An unhealthy transplanted organ may result in elevated levels of donor DNA in the host blood - a rise of only a few percent (e.g., as low as about 10, 5, 4, 3, 2, 1, 0.5, 0.1 or 0.01 % or less). The methods described herein may be sensitive enough to identify changes in allele frequency with the necessary sensitivity, and therefore may accurately determine the presence and changing amounts of donor DNA in host blood.

**[0058]** In another aspect, the methods of the present disclosure may comprise comparing the first and second numbers to determine the genetic variation in the genetic sample. In some embodiments, the comparing step comprises obtaining an estimate of a relative number of the nucleotide molecules having the first and second nucleic acid regions of interest.

**[0059]** In another aspect, the methods of the present disclosure may comprise labeling the first and second labeling probes with the first and second labels, respectively, prior to the contacting step (e.g., during manufacturing the probes). Labeling the probe may be performed simultaneously or after contacting the probes to the genetic sample, hybridizing, ligating, amplifying and/or immobilizing the probes. Moreover, labeling the probe may be performed simultaneously or before contacting the probes to the genetic sample, hybridizing, ligating, amplifying, and/or immobilizing the probes. Labeling a probe may comprise adding, immobilizing, or binding a label to the probe by a physical or chemical bond. Labels may be placed anywhere within the sequence of a probe, including at the 5' or 3'-end.

**[0060]** In another aspect, the methods of the present disclosure may comprise tagging the first and second tagging probes with first and second tags, respectively, prior to the contacting step. (e.g., during the manufacturing the probes). Tagging the probe may be performed simultaneously or after contacting the probes to the genetic sample, hybridizing, ligating, amplifying and/or labeling the probes. Moreover, tagging the probe may be performed simultaneously or before contacting the probes to the genetic sample, hybridizing, ligating, amplifying, immobilizing and/or labeling the probes. Tagging a probe may comprise adding, immobilizing, or binding a tag to the probe by a physical or chemical bond. Tags may be placed anywhere within the sequence of a probe, including at the 5' or 3'-end.

**[0061]** In another aspect, the probe sets herein may be designed to have tags according to the predetermined locations

to which the tags are to be immobilized. In some embodiments, the tags in all probe sets configured to detect a genetic variation are the same and are configured to be immobilized to same locations on the substrate directly or indirectly. In additional embodiments, the first and second tags are the same, and each of the rest of the tags is different from the first or second tag. In further embodiments, each or a group of members of the array of multiple predetermined locations on a substrate may have a unique tag to be immobilized.

**[0062]** In another aspect, the probe sets according to some embodiments may be amplified, and labeled probe sets may be produced during the process of amplification. In another aspect, each of the labeling probes may comprise a forward or reverse priming sequence, and each of the tagging probes may comprise a corresponding reverse or forward priming sequence and a tagging nucleotide sequence as a tag. The forward and reverse priming sequences are the sequences that are configured to hybridize to the corresponding forward and reverse primers, respectively. In some embodiments, the amplifying step comprises amplifying (i) the ligated first labeling and tagging probes with first forward and reverse primers hybridizing to the forward and reverse priming sequences, respectively, wherein the first forward or reverse primer hybridizing to the first labeling probe comprises the first label, and (ii) the ligated second labeling and tagging probes with second forward and reverse primers hybridizing to the forward and reverse priming sequences, respectively, wherein the second forward or reverse primer hybridizing to the second labeling probe comprises the second label. In additional embodiments, the amplified tagging nucleotide sequences of the tagging probes are immobilized to a pre-determined location on a substrate, wherein the amplified tagging nucleotide sequences of the first and second tagging probes are the first and second tags. In some embodiments, the first and second tags are the same and/or are configured to bind to the same location on the substrate. In another embodiment, the first and second tags are different and/or are configured to bind to different locations on the substrate. In further embodiments, when the probes are amplified, the method comprises counting numbers of the labels in the amplified probes and/or probe sets immobilized on the substrate. For example, the first number is the number of the first label in the amplified first probe set immobilized to the substrate, and the second number is the number of the second label in the amplified second probe set immobilized to the substrate.

**[0063]** In another aspect, the probe sets according to some embodiments may be amplified, and labeled probe sets may be produced using labeled reverse primers without using a forward primer. In another aspect, each of the labeling probes may comprise a reverse priming sequence, and each of the tagging probes may comprise a tagging nucleotide sequence as a tag. In some embodiments, the amplifying step may comprise amplifying (i) the ligated first labeling and tagging probes with a first reverse primer hybridizing to a first reverse priming sequence of the first labeling probe, wherein the first reverse primer comprises the first label, and (ii) the ligated second labeling and tagging probes with a second reverse primer hybridizing to a second reverse priming sequence of the second labeling probe, wherein the second reverse primer comprises the second label. In additional embodiments, the amplified tagging nucleotide sequences of the tagging probes are immobilized to a pre-determined location on a substrate, wherein the amplified tagging nucleotide sequences of the first and second tagging probes are the first and second tags. In further embodiments, the first number is the number of the first label in the amplified first probe set immobilized to the substrate, and the second number is the number of the second label in the amplified second probe set immobilized to the substrate.

**[0064]** In another aspect, the ligated probe sets according to some embodiments may be produced using a ligase chain reaction. In another aspect, the method described herein comprises contacting third and fourth probe sets to the genetic sample, wherein the third probe set comprises a third labeling probe and a third tagging probe, and the fourth probe set comprises a fourth labeling probe and a fourth tagging probe. The method may further comprise hybridizing the first and second probe sets to first and second sense nucleic acid strands of interest in single stranded nucleotide molecules from the double stranded nucleotide molecules of the genetic sample, respectively; and hybridizing the third and fourth probe sets to anti-sense nucleic acid strands of the first and second sense nucleic acid strands of interest, respectively. The method may further comprise producing ligated first, second, third, and fourth probe sets at least by ligating (i) the first labeling probe and the first tagging probe, (ii) the second labeling probe and the second tagging probe, (iii) the third labeling probe and the third tagging probe, and (iv) the fourth labeling probe and the fourth tagging probe. The method may further comprise performing a ligase chain reaction known in the art to amplify the ligated probe and/or ligated probe sets. In some embodiments, the ligase chain reaction may comprise hybridizing non-ligated first, second, third and fourth probe sets to the ligated third, fourth, first, and second probe sets, respectively, and ligating at least (i) the first labeling probe and the first tagging probe, (ii) the second labeling probe and the second tagging probe, (iii) the third labeling probe and the third tagging probe, and (iv) the fourth labeling probe and the fourth tagging probe of the non-ligated probe sets. The method may further comprise immobilizing the tagging probes to the pre-determined location on a substrate, wherein the first, second, third and fourth labeling probes ligated to the immobilized first, second, third and fourth tagging probes, respectively, comprise first, second, third and fourth labels, respectively; the immobilized labels are optically resolvable; the immobilized first, second, third and fourth tagging probes comprise first, second, third and fourth tags, respectively, and the immobilizing step is performed by immobilizing the tags to the predetermined location. The method may further comprise counting (i) the first sum of the first and third labels immobilized to the substrate, and (ii) the second sum of the second and fourth labels immobilized to the substrate, and comparing the first

and second sums to determine the genetic variation in the genetic sample. In yet additional embodiments, the method further comprises labeling the first, second, third and fourth labeling probes with the first, second, third and fourth labels, respectively, prior to the contacting step. In yet further embodiments, the first and third labels are the same, and the second and fourth labels are the same.

5 **[0065]** In another aspect, the method described herein comprises contacting third and fourth probe sets to the genetic sample, wherein the third probe set comprises a third labeling probe and a third tagging probe, and the fourth probe set comprises a fourth labeling probe and a fourth tagging probe, the first and third labeling probes comprises a first reverse priming sequence, the second and fourth labeling probes comprises a second reverse priming sequence, and each of the tagging probes comprises a tagging nucleotide sequence as a tag. The method may further comprise hybridizing the first and second probe sets to first and second sense nucleic acid strands of interest, respectively, in single stranded nucleotide molecules from double stranded nucleotide molecules of the genetic sample; and hybridizing at least parts of the third and fourth probe sets to anti-sense nucleic acid strands of the first and second sense nucleic acid strands of interest, respectively; producing ligated first, second, third, and fourth probe sets by ligating (i) the first labeling probe and the first tagging probe, (ii) the second labeling probe and the second tagging probe, (iii) the third labeling probe and the third tagging probe, and (iv) the fourth labeling probe and the fourth tagging probe. The method may further comprise performing a ligase chain reaction. In some embodiments, the ligase chain reaction comprises hybridizing at least parts of the non-ligated first, second, third and fourth probe sets to the ligated third, fourth, first, and second probe sets, respectively, and ligating (i) the first labeling probe and the first tagging probe, (ii) the second labeling probe and the second tagging probe, (iii) the third labeling probe and the third tagging probe, and (iv) the fourth labeling probe and the fourth tagging probe. The method may further comprise amplifying (i) the ligated first and third probe sets with a first reverse primer hybridizing to the first reverse priming sequence, wherein the first reverse primer comprises the first label, and (ii) the ligated second and fourth probe sets with a second reverse primer hybridizing to the second reverse priming sequence, wherein the second reverse primer comprises the second label, the amplified tagging nucleotide sequences of the tagging probes are immobilized to a pre-determined location on a substrate, wherein the amplified tagging nucleotide sequences of the first, second, third and fourth tagging probes are first, second, third and fourth tags, the first number is the number of the first label in the amplified first and third probe sets immobilized to the substrate, and the second number is the number of the second label in the amplified second and fourth probe sets immobilized to the substrate.

20 **[0066]** In another aspect, the ligated first and second labeling probes are at the 3'-end of the first and second ligated probe set and comprise first and second reverse priming sequences hybridizing to the first and second reverse primers, respectively. In some embodiments, the first and second reverse primers comprise the first and second labels. In additional embodiments, the ligated first and second tagging probes are at the 5'-end of the first and second ligated probe set. In further embodiments, the ligated first and second tagging probes are at the 5'-end of the first and second ligated probe set and comprise first and second corresponding forward priming sequences hybridizing to the first and second forward primers, respectively.

25 **[0067]** In another aspect, the method herein comprises digesting double stranded molecules in the sample to produce single stranded molecules. In some embodiments, the amplifying step comprises contacting an exonuclease to the amplified probe and/or probe set, and digesting the amplified probe and/or probe set from the 5'-end of one strand of the double stranded amplified probe and/or probe set. For example, the amplifying step comprises contacting an exonuclease to the amplified probe in a probe set, and digesting the amplified probe set from the 5'-end of one strand of the double stranded amplified probe set. In additional embodiments, the one strand of the amplified probe and probe set contacting the exonuclease does not have any label at the 5'-end. The contacting of the exonuclease to the unlabeled double stranded probes may digest the unlabeled strand from the 5'-end producing single stranded probes. In another aspect, the 5'-end of the amplified probe set comprising the label at the 5'-end may be protected from exonuclease digestion.

30 **[0068]** In another aspect, the method may detect from 1 to 100, from 1 to 50, from 2 to 40, or from 5 to 10 genetic variations; 2, 3, 4, 5, 6, 7, 8, 9, 10 or more genetic variations; and 100, 50, 30, 20, 10 or less genetic variations. In some embodiments, the method described herein may detect x number of genetic variations using at least (x+1) number of different probe sets. In these embodiments, a number of labels from one type of probe sets may be compared with one or more numbers of labels from the rest of the different types of probe sets. In some embodiments, the method described herein may detect genetic variation in a continuous manner across the entire genome at various resolutions, for example, at 300,000 base resolution such that 100 distributed variations across all chromosomes are separately interrogated and quantified. In additional embodiments, the base resolution is in the range of one or ten to 100 thousand nucleotides up to one million, ten million, or 100 million or more nucleotides.

35 **[0069]** In another aspect, the method according to some embodiments may detect at least two genetic variations. In some embodiments, the method described herein may further comprise contacting a fifth probe set to the genetic sample, wherein the fifth probe set comprises a fifth labeling probe and a fifth tagging probe. The method may further comprise hybridizing at least a part of the fifth probe set to the third nucleic acid region of interest in nucleotide molecules of the

genetic sample, wherein the third nucleic acid region of interest is different from the first and second nucleic acid regions of interest. The method may further comprise ligating the fifth probe set at least by ligating the fifth labeling probe and the fifth tagging probe. The method may further comprise amplifying the ligated probe sets. The method may further comprise immobilizing each of the tagging probe to a pre-determined location on a substrate, wherein the fifth labeling probe and/or the amplified labeling probe thereof ligated to the immobilized tagging probe comprise a fifth label, the fifth label is different from the first and second labels, the immobilized labels are optically resolvable, the immobilized fifth tagging probe and/or the amplified tagging probe thereof comprise a fifth tag, and the immobilizing step is performed by immobilizing the tags to the predetermined location. The method may comprise counting a third number of the fifth label immobilized to the substrate, and comparing the third number to the first and/or second number(s) to determine the second genetic variation in the genetic sample. In some embodiments, the subject may be a pregnant subject, the first genetic variation is trisomy 21 in the fetus of the pregnant subject, and the second genetic variation is selected from the group consisting of trisomy 13, trisomy 18, aneuploidy of X, and aneuploidy of Y in the fetus of the pregnant subject.

**[0070]** In another aspect, the method according to some embodiments may detect at least three genetic variations. In some embodiments, the method described herein further comprises contacting a sixth probe set to the genetic sample, wherein the sixth probe set comprises a sixth labeling probe and a sixth tagging probe. The method may further comprise hybridizing at least a part of the sixth probe set to the fourth nucleic acid region of interest in nucleotide molecules of the genetic sample, wherein the fourth nucleic acid region of interest is different from the first, second, and third nucleic acid regions of interest. The method may further comprise ligating the sixth probe set at least by ligating the sixth labeling probe and the sixth tagging probe. The method may further comprise amplifying the ligated probe sets. The method may further comprise immobilizing each of the tagging probes to a pre-determined location on a substrate, wherein the sixth labeling probe and/or the amplified labeling probe thereof ligated to the immobilized tagging probe comprise a sixth label, the sixth label is different from the first and second labels, the immobilized labels are optically resolvable, the immobilized sixth tagging probe and/or the amplified tagging probe thereof comprise a sixth tag, and the immobilizing step is performed by immobilizing the tags to the predetermined location. The method may further comprise counting a fourth number of the sixth label immobilized to the substrate, and comparing the fourth number to the first, second and/or third number to determine the third genetic variation in the genetic sample.

**[0071]** In another aspect, the method may according to some embodiments detect at least four genetic variations. In some embodiments, the method described herein further comprises contacting a seventh probe set to the genetic sample, wherein the seventh probe set comprises a seventh labeling probe and a seventh tagging probe. The method may further comprise hybridizing at least a part of the seventh probe set to the fifth nucleic acid region of interest in nucleotide molecules of the genetic sample, wherein the fifth nucleic acid region of interest is different from the first, second, third and fourth nucleic acid regions of interest. The method may further comprise ligating the seventh probe set at least by ligating the seventh labeling probe and the seventh tagging probe. The method may further comprise optionally amplifying the ligated probe sets. The method may further comprise immobilizing each of the tagging probes to a pre-determined location on a substrate, wherein the seventh labeling probe and/or the amplified labeling probe thereof ligated to the immobilized tagging probe comprise a seventh label, the seventh label is different from the first and second labels, the immobilized labels are optically resolvable, the immobilized seventh tagging probe and/or the amplified tagging probe thereof comprise a seventh tag, and the immobilizing step is performed by immobilizing the tags to the predetermined location. The method may further comprise counting a fifth number of the seventh label immobilized to the substrate, and comparing the fifth number to the first, second, third and/or fourth number(s) to determine the fourth genetic variation in the genetic sample.

**[0072]** In another aspect, the method according to some embodiments may detect at least five genetic variations. In some embodiments, the method described herein further comprises contacting an eighth probe set to the genetic sample, wherein the eighth probe set comprises an eighth labeling probe and an eighth tagging probe. The method may further comprise hybridizing at least a part of the eighth probe set to the sixth nucleic acid region of interest in nucleotide molecules of the genetic sample, wherein the sixth nucleic acid region of interest is different from the first, second, third, fourth, and fifth nucleic acid regions of interest. The method may further comprise ligating the eighth probe set at least by ligating the eighth labeling probe and the eighth tagging probe. The method may further comprise amplifying the ligated probe sets. The method may further comprise immobilizing each of the tagging probes to a pre-determined location on a substrate, wherein the eighth labeling probe and/or the amplified labeling probe thereof ligated to the immobilized tagging probe comprise an eighth label, the eighth label is different from the first and second labels, the immobilized labels are optically resolvable, the immobilized eighth tagging probe and/or the amplified tagging probe thereof comprise an eighth tag, and the immobilizing step is performed by immobilizing the tags to the predetermined location. The method may further comprise counting a sixth number of the eighth label immobilized to the substrate, and comparing the sixth number to the first, second, third, fourth and/or fifth number(s) to determine the fifth genetic variation in the genetic sample. In some embodiments, the subject is a pregnant subject, and the first, second, third, fourth, and fifth genetic variations are trisomy 13, trisomy 18, trisomy 21, aneuploidy X, and aneuploidy Y in the fetus of the pregnant subject.

**[0073]** In another aspect, the subject is a pregnant subject, the genetic variation is trisomy 21 in the fetus of the pregnant subject, the first nucleic acid region of interest is located in chromosome 21, and the second nucleic acid region of interest is not located in the chromosome 21.

**[0074]** In another aspect, the subject is a pregnant subject, the genetic variation is trisomy 21 in the fetus of the pregnant subject, the first nucleic acid region of interest is located in chromosome 21, and the second nucleic acid region of interest is located in chromosome 18.

**[0075]** In one aspect, the probe set herein may comprise two, three, four, five or more labeling probes, and/or two, three, four, five or more labels. In some embodiments, the method described herein may further comprise the first and second probe sets further comprise third and fourth labeling probes, respectively; the immobilized first probe set and/or amplified first probe set further comprise a ninth label in the third labeling probe and/or amplified product thereof; and the immobilized second probe set and/or amplified second probe set further comprise a tenth label in the fourth labeling probe and/or amplified product thereof. In these embodiments, if the ninth and tenth labels are different from the first and second labels, this method may be used to confirm the number counted for the first and second labels. If the ninth and tenth labels are the same from the first and second labels, respectively, this method may be used to improve the accuracy of detection labels immobilized to each of the nucleic acid regions of interest. For example, using multiple labels would be brighter than using one label, and therefore multiple labels may be more easily detected than one label.

**[0076]** In additional embodiments, (i) the immobilized first probe set and/or amplified first probe set further comprise an eleventh label in the labeling probe, and (ii) the immobilized second probe set and/or amplified second probe set further comprises a twelfth label that is different from the eleventh label in the labeling probe. In further embodiments, wherein the first, second, eleventh and twelfth labels are different from one another, and the counting step further comprises counting numbers of the eleventh and twelfth labels immobilized on the substrate.

**[0077]** In another aspect, the method described herein may be performed with a control sample. In some embodiments, the method may further comprise repeating the steps with a control sample different from the genetic sample from the subject. The method may further comprise counting control numbers of the labels immobilized to the substrate, and comparing the control numbers to the first, second, third, fourth, fifth and/or sixth number to confirm the genetic variation in the genetic sample.

**[0078]** In another aspect, the subject may be a pregnant subject, and the genetic variation is a genetic variation in the fetus of the pregnant subject. In such embodiments, the method may use a Single Nucleotide Polymorphism (SNP) site to determine whether the proportion (e.g., concentration, and number percentage based on the number of nucleotide molecules in the sample) of fetal material (e.g., the fetal fraction) is sufficient so that the genetic variation of the fetus may be detected from a sample from the pregnant subject with a reasonable statistical significance. In additional embodiments, the method may further comprise contacting maternal and paternal probe sets to the genetic sample, wherein the maternal probe set comprises a maternal labeling probe and a maternal tagging probe, and the paternal probe set comprises a paternal labeling probe and a paternal tagging probe. The method may further comprise hybridizing at least a part of each of the maternal and paternal probe sets to a nucleic acid region of interest in nucleotide molecules of the genetic sample, the nucleic acid region of interest comprising a predetermined SNP site, wherein the at least a part of the maternal probe set hybridizes to a first allele at the SNP site, the at least a part of the paternal probe set hybridizes to a second allele at the SNP site, and the first and second alleles are different from each other. The method may further comprise ligating the maternal and paternal probe sets at least by ligating (i) the maternal labeling and tagging probes, and (ii) the paternal labeling and tagging probes. The method may further comprise amplifying the ligated probes. The method may further comprise immobilizing the tagging probes to a pre-determined location on a substrate, wherein the maternal and paternal labeling probes and/or the amplified labeling probes thereof ligated to the immobilized tagging probes comprise maternal and paternal labels, respectively; the maternal and paternal labels are different, and the immobilized labels are optically resolvable. The method may further comprise counting the numbers of the maternal and paternal labels, and determining whether a proportion of a fetal material in the genetic sample is sufficient to detect the genetic variation in the fetus based on the numbers of the maternal and paternal labels. The method may further comprise determining the proportion of the fetal material in the genetic sample.

**[0079]** In some embodiments, when the subject is a pregnant subject, and the genetic variation is a genetic variation in the fetus of the pregnant subject, the method may further comprise contacting allele A and allele B probe sets that are allele-specific to the genetic sample, wherein the allele A probe set comprises an allele A labeling probe and an allele A tagging probe, and the allele B probe set comprises an allele B labeling probe and an allele B tagging probe. The method may further comprise hybridizing at least a part of each of the allele A and allele B probe sets to a nucleic acid region of interest in nucleotide molecules of the genetic sample, the nucleic acid region of interest comprising a predetermined single nucleotide polymorphism (SNP) site for which a maternal allelic profile (i.e., genotype) differs from a fetal allelic profile at the SNP site (For example, maternal allelic composition may be AA and fetal allelic composition may be AB, or BB. In another example, maternal allelic composition may be AB and fetal allelic composition may be AA, or BB.), wherein the at least a part of the allele A probe set hybridizes to a first allele at the SNP site, the at least a part of the allele B probe set hybridizes to a second allele at the SNP site, and the first and second alleles are different

from each other. The method may further comprise ligating the allele A and allele B probe sets at least by ligating (i) the allele A labeling and tagging probes, and (ii) the allele B labeling and tagging probes. The method may further comprise amplifying the ligated probe sets. The method may further comprise immobilizing the tagging probes to a pre-determined location on a substrate, wherein the allele A and allele B labeling probes and/or the amplified labeling probes thereof  
5 ligated to the immobilized tagging probes comprise allele A and allele B labels, respectively, the allele A and allele B labels are different, and the immobilized labels are optically resolvable. The method may further comprise counting the numbers of the allele A and allele B labels, and determining whether a proportion of a fetal material in the genetic sample is sufficient to detect the genetic variation in the fetus based on the numbers of the allele A and allele B labels. The method may further comprise determining the proportion of the fetal material in the genetic sample.

**[0080]** In some embodiments, when the subject is a pregnant subject, the genetic variation is a genetic variation in the fetus of the pregnant subject, and the genetic sample comprises a Y chromosome, the method may further comprise contacting maternal and paternal probe sets to the genetic sample, wherein the maternal probe set comprises a maternal labeling probe and a maternal tagging probe, and the paternal probe set comprises a paternal labeling probe and a paternal tagging probe. The method may further comprise hybridizing at least parts of the maternal and paternal probe  
15 sets to maternal and paternal nucleic acid regions of interest in nucleotide molecules of the genetic sample, respectively, wherein the paternal nucleic acid region of interest is located in the Y chromosome, and the maternal nucleic acid region of interest is not located in the Y chromosome. The method may further comprise ligating the maternal and paternal probe sets at least by ligating (i) the maternal labeling and tagging probes, and (ii) the paternal labeling and tagging probes. The method may further comprise amplifying the ligated probes. The method may further comprise nucleic acid region of interest comprising a predetermined single nucleotide polymorphism (SNP) site containing more than one  
20 SNP, for example two or three SNPs. Further, the SNP site may contain SNPs with high linkage disequilibrium such that labeling and tagging probes are configured to take advantage of the improved energetics of multiple SNP matches or mismatches versus only one. The method may further comprise immobilizing the tagging probes to a pre-determined location on a substrate, wherein the maternal and paternal labeling probes and/or the amplified labeling probes thereof  
25 ligated to the immobilized tagging probes comprise maternal and paternal labels, respectively, the maternal and paternal labels are different, and the immobilized labels are optically resolvable. The method may further comprise counting the numbers of the maternal and paternal labels, and determining whether a proportion of a fetal material in the genetic sample is sufficient to detect the genetic variation in the fetus based on the numbers of the maternal and paternal labels. The method may further comprise determining the proportion of the fetal material in the genetic sample.

**[0081]** In additional embodiments, other genetic variations (e.g., single base deletion, microsatellite, and small insertions) may be used in place of the genetic variation at the SNP site described herein.

**[0082]** In one aspect, the probe set described herein may comprise three or more probes, including at least one probe between the labeling and tagging probes. In some embodiments, the first and second probe sets further comprises first  
35 and second gap probes, respectively; the first gap probe hybridizes to a region between the regions where the first labeling probe and the first tagging probe hybridize; the second gap probe hybridizes to a region between the regions where the second labeling probe and the second tagging probe hybridize. The method may further comprise the ligating step comprises ligating at least (i) the first labeling probe, the first tagging probe, and the first gap probe, and (ii) the second labeling probe, the second tagging probe, and the second gap probe. In additional embodiments, the gap probe may comprise a label. For example, the first and second gap probes and/or amplified products thereof are labeled with  
40 labels (e.g., thirteenth and fourteenth labels, respectively), and each of the labels may be different from the rest of the labels (e.g., the first and second labels). The labels in the gap probes (e.g., thirteenth and fourteenth labels) may be the same or different from each other. In another aspect, the first and second labeling probes are hybridized to the first and second nucleic acid regions of interest in nucleotide molecules of the genetic sample, respectively; the first and second tagging probes are hybridized to the first and second nucleic acid regions of interest in nucleotide molecules of the  
45 genetic sample, respectively; the first and second gap probes are hybridized to the first and second nucleic acid regions of interest in nucleotide molecules of the genetic sample, respectively. In some embodiments, there are from 0 to 100 nucleotides, 1 to 100 nucleotides, 2 to 50 nucleotides; 3 to 30 nucleotides, 0, 1, 2, 3, 4, 5, 6, 7, 8, 9, 10, 20, 30, 40, 50, 100, 150, or 200 or more; or 1, 2, 3, 4, 5, 6, 7, 8, 9, 10, 15, 25, 35, 45, 55, 110, 160, or 300 or less between the regions where the first labeling probe and tagging probes are hybridized; and there are from 0 to 100 nucleotides, 1 to 100  
50 nucleotides, 2 to 50 nucleotides; 3 to 30 nucleotides, 0, 1, 2, 3, 4, 5, 6, 7, 8, 9, 10, 20, 30, 40, 50, 100, 150, or 200 nucleotides or more; or 1, 2, 3, 4, 5, 6, 7, 8, 9, 10, 15, 25, 35, 45, 55, 110, 160, or 300 nucleotides or less between the regions where the second labeling probe and tagging probes are hybridized. In additional embodiments, the gap probe between a labeling probe and a tagging probe may have a length from 0 to 100 nucleotides, 1 to 100 nucleotides, 2 to 50 nucleotides; 3 to 30 nucleotides, 0, 1, 2, 3, 4, 5, 6, 7, 8, 9, 10, 20, 30, 40, 50, 100, 150, or 200 or more; or 1, 2, 3, 4,  
55 5, 6, 7, 8, 9, 10, 15, 25, 35, 45, 55, 110, 160, or 300 or less.

**[0083]** In another aspect, the probe set described herein may comprise a spacer ligated and/or conjugated to the labeling probe and the tagging probe. The spacer may or may not comprise oligonucleotides. The spacer may comprise an isolated, purified, naturally-occurring, or non-naturally occurring material, including oligonucleotide of any length (e.g.,

5, 10, 20, 30, 40, 50, 100, or 150 nucleotides or less). In some embodiments, the probe may be in a purified restriction digest or produced synthetically, recombinantly or by PCR amplification. For example, the first labeling and tagging probes are conjugated by a first spacer, the second labeling and tagging probes are conjugated by a second spacer, and the first and second spacers are not hybridized to the nucleotide molecules of the genetic sample. In some embodiments, the method further comprises digesting the hybridized genetic sample with an enzyme, and breaking a bond in the first and second spacers after the digestion.

**[0084]** In another aspect, the method described herein excludes identifying a sequence in the nucleotide molecules of the genetic sample, and/or sequencing of the nucleic acid region(s) of interest and/or the probes. In some embodiments, the method excluding sequencing of the probes includes excluding sequencing a barcode and/or affinity tag in a tagging probe. In additional embodiments, the immobilized probe sets to detect different genetic variations, nucleotide regions of interest, and/or peptides of interest need not be detected or scanned separately because sequencing is not required in the methods described herein. In additional embodiments, the numbers of different labels immobilized to the substrate were counted simultaneously (e.g., by a single scanning and/or imaging), and thus the numbers of different labels were not separately counted. In another aspect, the method described herein excludes bulk array readout or analog quantification. The bulk array readout herein means a single measurement that measures the cumulative, combined signal from multiple labels of a single type, optionally combined with a second measurement of the cumulative, combined signal from numerous labels of a second type, without resolving a signal from each label. A result is drawn from the combination of the one or more such measurements in which the individual labels are not resolved. In another aspect, the method described herein may include a single measurement that measures the same labels, different labels of the same type, and/or labels of the same type in which the individual labels are resolved. The method described herein may exclude analog quantification and may employ digital quantification, in which only the number of labels is determined (ascertained through measurements of individual label intensity and shape), and not the cumulative or combined optical intensity of the labels.

**[0085]** In another aspect, the probe set described herein may comprise a binder. A binder is the same material as the tag or affinity tag describe herein. In some embodiments, the method further comprises immobilizing the binder to a solid phase after the ligating steps. The method may further comprise isolating the ligated probe sets from non-ligated probes. In additional embodiments, the binder comprises biotin, and the solid phase comprises a magnetic bead.

**[0086]** In another aspect, the counting step described herein may further comprise calibrating, verifying, and/or confirming the counted numbers. Calibrating herein means checking and/or adjusting the accuracy of the counted number. Verifying and confirming herein mean determining whether the counted number is accurate or not, and/or how much the error is, if exists.

**[0087]** In another aspect, intensity and/or single-to-noise is used as a method of identifying single labels. When dye molecules or other optical labels are in close proximity, they are often impossible to discriminate with fluorescence-based imaging due to the intrinsic limit of the diffraction of light. That is, two labels that are close together will be indistinguishable with no visible gap between them. One exemplary method for determining the number of labels at a given location is to examine the relative signal and/or signal-to-noise compared to locations known to have a single fluor. Two or more labels will usually emit a brighter signal (and one that can more clearly be differentiated from the background) than will a single fluor. Figure 2 shows the normalized histogram of signal intensity measured from both single label samples and multi-label antibodies (both Alexa 546; verified through bleach profiles). The two populations were clearly separable, and multiple labels may be clearly distinguished from single labels.

**[0088]** In some embodiments, the counting step may comprise measuring optical signals from the immobilized labels, and calibrating the counted numbers by distinguishing an optical signal from a single label from the rest of the optical signals from background and/or multiple labels. In some embodiments, the distinguishing comprises calculating a relative signal and/or single-to-noise intensity of the optical signal compared to an intensity of an optical signal from a single label. The distinguishing may further comprise determining whether the optical signal is from a single label. In additional embodiments, the optical signal is from a single label if the relative signal and/or single-to-noise intensity of an optical signal differs from an intensity of an optical signal from a single label by a predetermined amount or less. In further embodiments, the predetermined amount is from 0% to 100%, from 0% to 150%, 10% to 200%, 0, 1, 2, 3, 4, 5, 10, 20, 30, or 40% or more, and/or 300, 200, 100, 50, 30, 10, or 5% or less of the intensity of the optical signal from a single label.

**[0089]** In another aspect, different labels may have different blinking and bleaching properties. They may also have different excitation properties. In order to compare the number of dye molecules for two different labels, it is necessary to ensure that the two dyes are behaving in a similar manner and have similar emission characteristics. For example, if one dye is much dimmer than another, the number of molecules may be under-counted in this channel. Several factors may be titrated to give the optimal equivalence between the dyes. For example, the counting step and/or calibrating step may comprise optimizing (i) powers of light sources to excite the labels, (ii) types of the light sources, (ii) exposure times for the labels, and/or (iv) filter sets for the labels to match the optical signals from the labels, and measuring optical signals from the labels. These factors may be varied singly or in combination. Further, the metric being optimized may vary. For example, it may be overall intensity, signal-to-noise, least background, lowest variance in intensity or any other

characteristic.

**[0090]** Bleaching profiles are label specific and may be used to add information for distinguishing label types. Figure 3 shows average bleaching profiles from various labels. The plot shows the normalized counts per label type as a function of successive images that were collected over a 60 second interval. Item c1 is Cy3 fluor, item c2 is Atto647 fluor, and item c3 is Alexa488 fluor.

**[0091]** In another aspect, blinking behavior may be used as a method of identifying single labels. Many dye molecules are known to temporarily go into a dark state (e.g., Burnette et al., Proc. Natl. Acad. Sci. USA (2011) 108: 21081-21086). This produces a blinking effect, where a label will go through one or more steps of bright-dark-bright. The length and number of these dark periods may vary. The current invention uses this blinking behavior to discriminate one label from two or more labels that may appear similar in diffraction limited imaging. If there are multiple labels present, it is unlikely the signal will completely disappear during the blinking. More likely is that the intensity will fall as one of the labels goes dark, but the others do not. The probability of all the labels blinking simultaneously (and so looking like a single fluor) may be calculated based on the specific blinking characteristics of a dye.

**[0092]** In some embodiments, the optical signals from the labels are measured for at least two time points, and an optical signal is from a single label if the intensity of the optical signal is reduced by a single step function. In some embodiments, the two time points may be separated by from 0.1 to 30 minutes, from 1 second to 20 minutes, from 10 seconds to 10 minutes; 0.01, 0.1, 1, 2, 3, 4, 5, 10, 20, 30, 40, 50, 60 seconds or more; and/or 1, 2, 3, 4, 5, 10, 20, 30, 40, 50, 60 seconds or less. In additional embodiments, an intensity of the optical signal from a single label has a single step decrease over time, and an intensity of the optical signal from two or more labels has multiple step decreases over time. In further embodiments, the optical signals from the labels are measured for at least two time points and are normalized to bleaching profiles of the labels. In another aspect, the method described herein and/or the counting step may further comprises measuring an optical signal from a control label for at least two time points, and comparing the optical signal from the control label with the optical signals from the labels to determine an increase or decrease of the optical signal from the labels.

**[0093]** In another aspect, the counting step further comprises confirming the counting by using a control molecule. A control molecule may be used to determine the change in frequency of a molecule type. Often, the experimental goal is to determine the abundance of two or more types of molecules either in the absolute or in relation to one another. Consider the example of two molecules labeled with two different dyes. If the null hypothesis is that they are at equal frequency, they may be enumerated on a single-molecule array and the ratio of the counts compared to the null hypothesis. The "single-molecule array" herein is defined as an array configured to detect a single molecule, including, for example, the arrays described in U.S. Patent Application Publication No. 2013/0172216. If the ratio varies from 1:1, this implies they two molecules are at different frequencies. However, it may not be clear a priori whether one has increased abundance or the other has decreased abundance. If a third dye is used as a control molecule that should also be at equal frequency, this should have a 1:1 ratio with both the other dyes. Consider the example of two molecules labeled with dyes A and B, the goal being to see if the molecule labeled with dye B is at increased or decreased frequency compared to the molecule labeled with dye A. A third molecule labeled with dye C is included in the experiment in a way that it should be at the same abundance as the other two molecules. If the ratio of molecules labeled A and B respectively is 1:2, then either the first molecule has decreased frequency or the second has increased frequency. If the ratio of the molecules labeled A and C is 1:1 and the ratio of molecules labeled B and C is 1:2, then it is likely that the molecule labeled with dye B has increased with frequency with respect to the molecule labeled with dye A. An example of this would be in determining DNA copy number changes in a diploid genome. It is important to know if one sequence is amplified or the other deleted and using a control molecule allows for this determination. Note the control may be another region of the genome or an artificial control sequence.

**[0094]** In some embodiments, the results of the method described herein (e.g., counted numbers of labels) may be confirmed by using different labels but the same tags used in the initial method. Such confirming may be performed simultaneously with the initial method or after performing the initial method. In additional embodiments, the confirming described herein comprises contacting first and second control probe sets to the genetic sample, wherein the first control probe set comprises a first control labeling probe and the first tagging probe, which is the same tag of the first probe set described herein, and the second control probe set comprises a second control labeling probe and the second tagging probe, which is the same tag of the second probe set described herein. The confirmation may further comprise hybridizing at least a part of the first and second control probe sets to the first and second nucleic acid regions of interest in nucleotide molecules of the genetic sample, respectively. The confirmation may further comprise ligating the first control probe set at least by ligating the first control labeling probe and the first tagging probe. The confirmation may further comprise ligating the second control probe set at least by ligating the second control labeling probe and the second tagging probe. The confirmation may further comprise amplifying the ligated probe sets. The confirmation may further comprise immobilizing each of the tagging probes to a pre-determined location on a substrate, wherein the first and second control labeling probes and/or the amplified labeling probes thereof ligated to the immobilized tagging probes comprise first and second control labels, respectively, the first and second control labels are different, and the immobilized labels are

optically resolvable. The confirmation may further comprise measuring the optical signals from the control labels immobilized to the substrate. The confirmation may further comprise comparing the optical signals from the immobilized first and second control labels to the optical signals from the immobilized first and second labels to determine whether an error based on the labels exists. The "error based on a label" used herein means any error caused by the label that may not have occurred if a different label is used in the method. In some embodiments, the first label and the second control label are the same, and the second label and the first control label are the same.

**[0095]** Bleaching may be used as a method of identifying single labels. A key element of the readout is that individual labels be "resolvable," i.e., distinct. This is trivial at low densities on a surface when the likelihood of labels in close proximity is very low. For higher densities, assuming the labels are at random locations (i.e., Poissonian), the chances of close neighbors increases to the point where significant numbers of labels have neighbors whose fluorescent emission partially (or fully) overlaps with their own emission. At this point, the labels are no longer "resolvable," and in a transition regime exists between single-label detection (i.e., digital detection) and classic multi-label array-type detection (e.g., analogue detection) where the average signal from many molecules is measured. Put differently, a digital counting regime of individual molecules is switched to an analog regime of average-fluorescent-intensity from many molecules.

**[0096]** One solution to increase the loading range while maintaining individual resolvability is to take advantage of fluorophore bleaching. Extended exposure to light may cause labels to bleach, that is, lose their property of fluorescence. That is, over time, a label may be extinguished. This usually occurs as a step function, with the label appearing to "switch off." The current invention may use this bleaching behavior to discriminate one label from two or more labels that may appear similar in diffraction limited imaging. For multiple labels, extinction would be expected to occur via a series of step-wise decreases in the signal intensity. For example, Figures 4-13 show the integrated label intensity vs. time (showing bleaching events as changes in intensity) graphs that were obtained for various Alexa 488 labels. Single versus multiple label species may be easily differentiated (e.g. depending on whether the intensity of the optical signal is reduced by single versus multiple step(s) as shown in the graphs).

**[0097]** In another aspect, the method herein may comprise calibrating and/or confirming the counted numbers by label swapping or dye swapping. In some embodiments where probe product 1 and 2 are labeled with labels 1 and 2, respectively, various modes of error may mimic the differential frequency of the probe products. For example, if a ratio of 1:2 is observed between label 1 and label 2, this may be due to genuine differences in frequency (probe product 2 is twice as common as probe product 1), differences in hybridization efficiency (the probe products are at equal abundance, but probe product 2 hybridizes more efficiently than probe product 1) or differences in the properties of the labels (for example, if the labels are fluorescent dyes, label 1 may bleach faster, blink more frequently, give lower signal or lower signal-to-noise than label 2). If the same experiment is repeated with the labels switched, the ratio should be reversed, if it is a genuine observation of different frequencies of the molecules, with label 1 now twice as common as label 2. However, if it is due to differential hybridization efficiency the ratio will be  $\leq 2:1$ . If the 1:2 ratio was due to the properties of the labels, the ratio will switch to 2:1 of label 1 to label 2 if they are actually at equal frequency. This approach can be extended to any number of labeled probe sets.

**[0098]** In some embodiments, the first nucleic acid region of interest is located in a first chromosome, and the second nucleic acid region of interest is located in a second chromosome, different from the first chromosome. The counting step may further comprise confirming the counting, wherein the confirming step comprises contacting first and second control probe sets to the genetic sample, wherein the first control probe set comprises a first control labeling probe and a first control tagging probe, and the second control probe set comprises a second control labeling probe and the second control tagging probe. The confirming step may further comprise hybridizing at least a part of the first and second control probe sets to first and second control regions located in the first and second chromosomes, respectively, wherein the first and second control regions are different from the first and second nucleic acid regions of interest. The confirming step may further comprise ligating the first and second control probe sets at least by ligating (i) the first control labeling and tagging probes, and (ii) the second control labeling and tagging probes. The confirming step may further comprise amplifying the ligated probe sets. The confirming step may further comprise immobilizing (i) the first probe set and the second control probe set to a first pre-determined location, and (ii) the second probe set and the first control probe set to a second pre-determined location. In some embodiments, the first and second control labeling probes and/or the amplified labeling probes thereof ligated to the immobilized tagging probes comprise a first and second control labels, respectively, the first label and the second control label are different, the second label and the first control labels are different, the immobilized labels are optically resolvable, the immobilized first and second control tagging probes and/or the amplified tagging probes thereof comprise first and second control tags, respectively, and the immobilizing step is performed by immobilizing the tags to the predetermined locations. The confirming step may further comprise measuring the optical signals from the control labels immobilized to the substrate. The confirming step may further comprise comparing the optical signals from the immobilized control labels to the optical signals from the immobilized first and second labels to determine whether an error based on the nucleic acid region of interest exists. In further embodiments, the first tag and the second control tag are the same, and the second tag and the first control tag are the same.

**[0099]** In another aspect, the counting step of the method described herein may further comprise calibrating and/or

confirming the counted numbers by (i) repeating some or all the steps of the methods (e.g., steps including the contacting, binding, hybridizing, ligating, amplifying, and/or immobilizing) described herein with a different probe set(s) configured to bind and/or hybridize to the same nucleotide and/or peptide region(s) of interest or a different region(s) in the same chromosome of interest, and (ii) averaging the counted numbers of labels in the probe sets bound and/or hybridized to the same a nucleotide and/or peptide region of interest or to the same chromosome of interest. In some embodiments, the averaging step may be performed before the comparing step so that the averaged counted numbers of labels in a group of different probe sets that bind and/or hybridize to the same nucleotide and/or peptide region of interest are compared, instead of the counted numbers of the labels in the individual probe sets. In another aspect, the method described herein may further comprise calibrating and/or confirming the detection of the genetic variation by (i) repeating some or all the steps of the methods (e.g., steps including the contacting, binding, hybridizing, ligating, amplifying, immobilizing, and/or counting) described herein with different probe sets configured to bind and/or hybridize to control regions that does not have any known genetic variation, and (ii) averaging the counted numbers of labels in the probe sets bound and/or hybridized to the control regions. In some embodiments, the averaged numbers of the labels in the probe sets that bind and/or hybridize to control regions are compared to the numbers of the labels in the probe sets that bind and/or hybridized to the regions of interest described herein to confirm the genetic variation in the genetic sample. In another aspect, the steps of the calibrating and/or confirming may be repeated simultaneously with the initial steps, or after performing the initial steps.

**[0100]** In another aspect, labels (e.g., fluorescent dyes) from one or more populations may be measured and/or identified based on their underlying spectral characteristics. Most fluorescent imaging systems include the option of collecting images in multiple spectral channels, controlled by the combination of light source and spectral excitation/emission/dichroic filters. This enables the same fluorescent species on a given sample to be interrogated with multiple different input light color bands as well as capturing desired output light color bands. Under normal operation, excitation of a fluorophore is achieved by illuminating with a narrow spectral band aligned with the absorption maxima of that species (e.g., with a broadband LED or arclamp and excitation filter to spectrally shape the output, or a spectrally homogenous laser), and the majority of the emission from the fluorophore is collected with a matched emission filter and a long-pass dichroic to differentiate excitation and emission (Figure 14). In alternate operations, the unique identity of a fluorescent moiety may be confirmed through interrogation with various excitation colors and collected emission bands different from (or in addition to) the case for standard operation (Figure 15). The light from these various imaging configurations, e.g., various emission filters, is collected and compared to calibration values for the fluorophores of interest (Figure 16). In the example case, the experimental measurement (dots) matches the expected calibration/reference data for that fluorophore (triangles) but does not agree well with an alternate hypothesis (squares). Given test and calibration data for one or more channels, a goodness-of-fit or chi-squared may be calculated for each hypothesis calibration spectrum, and the best fit selected, in an automated and robust fashion. Various references may be of interest, including fluorophores used in the system, as well as common fluorescent contaminants, e.g., those with a flat emission profile (Contaminant 1; triangle), or a blue-weighted profile (Contaminant 2; stars) (Figure 17).

**[0101]** The design constraints for filter selection may be different from standard designs for which the goal is simply to maximize collected light in a single channel while avoiding significant contributions from other channels. In our invention the goal is spectral selectivity rather than solely light collection. For example, consider two fluorophores with significantly-different excitation bands, shown in Figure 18 (note, only the excitation regions are shown and no excitation spectra). A standard design would maximize the capture of Fluor 1 emission (with Em1 filter, solid line) and minimize catching the leading edge from Fluor 2, and Fluor 2 would be optimally captured by Em2 (which is slightly red-shifted to avoid significant collection of Fluor 1 light). In our design, verifying the presence of Fluor 2 with the Em1 filter is desired leading to widening of the band to be captured ("Em1+", fine dashed line). This creates additional information to verify the identity of Fluor 2. Similarly, Em2 may be widened or shifted towards Fluor 1 to capture more of that fluor's light (Em2+, fine dashed line). This increase in spectral information must also be balanced with the total available light from a given fluorophore to maintain detectability. Put differently, the contribution from a given fluorophore in a given channel is only significant if the corresponding signal is above the background noise, and therefore informative, unless a negative control is intended. In this way, the spectral signature of a fluorescent entity may be used for robust identification and capturing more light may be a second priority if species-unique features may be more effectively quantitated.

**[0102]** Given probe products may be labeled with more than one type of fluorophore such that the spectral signature is more complex. For example, probe products may always carry a universal fluor, e.g., Alexa647, and a locus-specific fluorophore, e.g., Alexa 555 for locus 1 and Alexa 594 for locus 2. Since contaminants will rarely carry yield the signature of two fluors, this may further increase the confidence of contamination rejection. Implementation would involve imaging in three or more channels in this example such that the presence or absence of each fluor may be ascertained, by the aforementioned goodness-of-fit method comparing test to reference, yielding calls of locus 1, locus 2 or not a locus product. Adding extra fluors aids fluor identification since more light is available for collection, but at the expense of yield of properly formed assay products and total imaging time (extra channels may be required). Other spectral modifiers may also be used to increase spectral information and uniqueness, including FRET pairs that shift the color when in

close proximity or other moieties.

**[0103]** In another aspect, as described herein, the method of the present disclosure may be used to detect a genetic variation in peptide or proteins. In such as case, the methods may comprise contacting first and second probe sets to the genetic sample, wherein the first probe set comprises a first labeling probe and a first tagging probe, and the second probe set comprises a second labeling probe and a second tagging probe. The methods may further comprise binding the probe sets to peptide regions of interest by a physical or chemical bond, in place of the hybridizing step described herein in the case of detecting the genetic variation in nucleic acid molecules. Specifically, the methods may further comprise binding at least parts of the first and second probe sets to first and second peptide regions of interest in a peptide of protein of the genetic sample, respectively. For example, the binding may be performed by having a binder in at least one probe in the probe set that specifically binds to the peptide region of interest.

**[0104]** In some embodiments, the methods to detect a genetic variation in peptide or proteins may further comprise conjugating the first probe set by a chemical bond at least by conjugating the first labeling probe and the first tagging probe, and conjugating the second probe set at least by conjugating the second labeling probe and the second tagging probe, in place of the ligating step described herein in the case of detecting the genetic variation in nucleic acid molecules. The method may further comprise immobilizing the tagging probes to a pre-determined location on a substrate as described herein. In additional embodiments, the first and second labeling probes conjugated to the immobilized tagging probes comprise first and second labels, respectively; the first and second labels are different; the immobilized labels are optically resolvable; the immobilized first and second tagging probes and/or the amplified tagging probes thereof comprise first and second tags, respectively; and the immobilizing step is performed by immobilizing the tags to the predetermined location. The methods may further comprise, as described herein, counting (i) a first number of the first label immobilized to the substrate, and (ii) a second number of the second label immobilized to the substrate; and comparing the first and second numbers to determine the genetic variation in the genetic sample.

**[0105]** A system to detect a genetic variation according to the methods described herein includes various elements. Some elements include transforming a raw biological sample into a useful analyte. This analyte is then detected, generating data that are then processed into a report. Various modules that may be included in the system are shown in Figure 19. More details of various methods for analyzing data, including e.g., image processing, are shown in Figure 20. Analysis may be performed on a computer, and involve both a network connected to the device generating the data and a data server for storage of data and report. Optionally, additional information beyond the analyte data may be incorporated into the final report, e.g., maternal age or prior known risks. In some embodiments, the test system includes a series of modules, some of which are optional or may be repeated depending on the results of earlier modules. The test may comprise: (1) receiving a requisition, e.g., from an ordering clinician or physician, (2) receiving a patient sample, (3) performing an assay including quality controls on that sample resulting in a assay-product on an appropriate imaging substrate (e.g., contacting, binding, and/or hybridizing probes to a sample, ligating the probes, optionally amplifying the ligated probes, and immobilizing the probes to a substrate as described herein), (4) imaging the substrate in one or more spectral channels, (5) analyzing image data, (6) performing statistical calculations (e.g., comparing the first and second numbers to determine the genetic variation in the genetic sample), (7) creating and approving the clinical report, and (8) returning the report to the ordering clinician or physician. The test system may comprise a module configured to receive a requisition, e.g., from an ordering clinician or physician, a module configured to receive a patient sample, (3) a module configured to perform an assay including quality controls on that sample resulting in a assay-product on an appropriate imaging substrate, (4) a module configured to image the substrate in one or more spectral channels, (5) a module configured to analyze the image data, (6) a module configured to perform statistical calculations, (7) a module configured to create and confirm the clinical report, and and/or (8) a module configured to return the report to the ordering clinician or physician.

**[0106]** In one aspect, the assays and methods described herein may be performed on a single input sample simultaneously. For example, the method may comprise verifying the presence of fetal genomic molecules at or above a minimum threshold as described herein, followed by a step of estimating the target copy number state if and only if that minimum threshold is met. Therefore, one may separately run an allele-specific assay on the input sample for performing fetal fraction calculation, and a genomic target assay for computing the copy number state. In other embodiments, both assays and methods described herein may be carried out in parallel on the same sample at the same time in the same fluidic volume. Further quality control assays may also be carried out in parallel with the same universal assay processing steps. Since tags, affinity tags, and/or tagging probes in the probe products, ligated probe set, or labeled molecule to be immobilized to the substrate may be uniquely designed for every assay and every assay product, all of the parallel assay products may be localized, imaged and quantitated at different physical locations on the imaging substrate. In another aspect, the same assay or method (or some of their steps) described herein using the same probes and/or detecting the same genetic variation or control may be performed on multiple samples simultaneously either in the same or different modules (e.g., testing tube) described herein. In another aspect, assays and methods (or some of their steps) described herein using different probes and/or detecting different genetic variations or controls may be performed on single or multiple sample(s) simultaneously either in the same or different modules (e.g., testing tube).

[0107] In another aspect, image analysis may include image preprocessing, image segmentation to identify the labels, characterization of the label quality, filtering the population of detected labels based on quality, and performing statistical calculations depending on the nature of the image data. In some instances, such as when an allele-specific assay is performed and imaged, the fetal fraction may be computed. In others, such as the genomic target assay and imaging, the relative copy number state between two target genomic regions is computed. Analysis of the image data may occur in real-time on the same computer that is controlling the image acquisition, or on a networked computer, such that results from the analysis may be incorporated into the test workflow decision tree in near real-time.

[0108] In another aspect, steps (4) and (5) of the test above may be repeated multiple times for different portions of the imaging substrate such that the results dictate next steps. For example, the tests and methods described herein comprise confirming the presence and precise level of a fetal sample in a genetic sample obtained from a subject before testing for the relative copy number state of genomic targets. As described herein, an allele sensitive assay may be used to quantify the levels of fetal DNA relative to maternal DNA. The resulting probe products may be pulled down to a fetal fraction region 1 on the substrate, and imaged. In some embodiments, if and only if the calculated fetal fraction is above the minimum system requirement, the test may proceed and yield a valid result. In this way, testing of samples that fail to confirm at least the minimum input fetal fraction may be terminated before additional imaging and analysis takes place. Conversely, if the fetal fraction is above the minimum threshold, further imaging (step 4 of the test) of the genomic targets (e.g., chromosome 21, 18 or 13) may proceed followed by additional analysis (step 5 of the test). Other criteria may also be used and tested.

[0109] In another aspect, not every SNP probed in the allele-specific assay may result in useful information. For example, the maternal genomic material may have heterozygous alleles for a given SNP (e.g., allele pair AB), and the fetal material may also be heterozygous at that site (e.g., AB), hence the fetal material is indistinguishable and calculation of the fetal fraction fails. Another SNP site for the same input sample, however, may again show the maternal material to be heterozygous (e.g., AB) while the fetal material is homozygous (e.g., AA). In this example, the allele-specific assay may yield slightly more A counts than B counts due to the presence of the fetal DNA, from which the fetal fraction may be calculated. Since the SNP profile (i.e., genotype) cannot be known a priori for a given sample, multiple or numerous SNP sites should be designed such that nearly every possible sample will yield an informative SNP site. Each SNP site may be localized to a different physical location on the imaging substrate, for example by using a different tag for each SNP. However, for a given test, the fetal fraction may only be calculated successfully once. Therefore, a single or multiple locations on the substrate used to interrogate SNPs may be imaged and analyzed (e.g., in groups of one, two, three, four, five, ten, twenty, fifty or less and/or one, two, three, four, five, ten, twenty, fifty or more) until an informative SNP is detected. By alternating imaging and analysis, one may bypass imaging all possible SNP spots and significantly reduce average test duration while maintaining accuracy and robustness.

[0110] In another aspect, determining the fetal fraction of a sample may aide other aspects of the system beyond terminating tests for which the portion of fetal fraction in a sample is inadequate. For example, if the fetal fraction is high (e.g., 20%) then for a given statistical power, the number of counts required per genetic target (e.g., chr21) will be lower; if the fetal fraction is low (e.g., 1%) then for the same statistical power, a very high number of counts is required per genomic target to reach the same statistical significance. Therefore, following (4-1) imaging of the fetal fraction region 1, (5-1) analysis of those data resulting in a required counting throughput per genomic target, (4-2) imaging of genomic target region 2 commences at the required throughput, followed by (5-2) analysis of those image data and the test result for genomic variation of the input targets.

[0111] In another aspect, steps (4) and (5) of the test above may be repeated further for quality control purposes, including assessment of background levels of fluors on the imaging substrate, contaminating moieties, positive controls, or other causes of copy number variation beyond the immediate test (e.g., cancer in the mother or fetus, fetal chimerism, twinning). Because image analysis may be real-time, and does not require completion of the entire imaging run before generating results (unlike DNA sequencing methods), intermediate results may dictate next steps from a decision tree, and tailor the test for ideal performance on an individual sample. Quality control may also encompass verification that the sample is of acceptable quality and present, the imaging substrate is properly configured, that the assay product is present and/or at the correct concentration or density, that there is acceptable levels of contamination, that the imaging instrument is functional and that analysis is yielding proper results, all feeding in to a final test report for review by the clinical team.

[0112] In another aspect, the test above comprises one or more of the following steps: (1) receiving a requisition (from, for example, an ordering clinician or physician), (2) receiving a patient sample, (3) performing an assay (including an allele-specific portion, genomic target portion and quality controls) on that sample resulting in an assay-product-containing imaging substrate, (4-1) imaging the allele-specific region of the substrate in one or more spectral channels, (5-1) analyzing allele-specific image data to compute the fetal fraction, (pending sufficient fetal fraction) (4-2) imaging the genomic target region of the substrate in one or more spectral channels, (5-2) analyzing genomic target region image data to compute the copy number state of the genomic targets, (4-3) imaging the quality control region of the substrate in one or more spectral channels, (5-3) analyzing quality control image data to compute validate and verify the test, (6)

performing statistical calculations, (7) creating and approving the clinical report, and (8) sending the report back to the ordering clinician or physician.

**[0113]** In the following description, various exemplary embodiments are set forth in view of the Figures.

**[0114]** Figure 21 is an implementation of an assay for quantifying genomic copy number at two genomic loci. In this embodiment of the assay, 105 and 106 are target molecules. 105 contains sequence corresponding to the first genomic locus "Locus 1" interrogated for copy number (example, chromosome 21), and 106 contains sequence corresponding to the second genomic locus "Locus 2" interrogated for copy number (example, chromosome 18). Figure 21 contains an example of one probe set per genomic locus, but in some embodiments of this assay, multiple probe sets will be designed to interrogate multiple regions within a genomic locus. For example, more than 10, or more than 100, or more than 500 probe sets may be designed that correspond to chromosome 21. Figure 21 illustrates only a single probe set for each genomic locus, but importantly the scope of this invention allows for multiple probe sets for each genomic locus. Figure 21 also illustrates a single hybridization event between a target molecule and a probe set. In practice, there will be multiple target molecules present in an assay sample. Many target molecules will contain the necessary sequences for hybridization to a probe set, and formation of a probe product. Different target molecules may hybridize to probe sets, as certain target molecules will bear genetic polymorphisms. In addition, target molecules that arise from genomic DNA may have a random assortment of molecule sizes, as well various beginning and ending sequences. In essence, there are multiple target molecules that may hybridize to a given probe set. In a single assay, multiple copies of a given probe set are added. Therefore, in a single assay up to thousands, or hundreds of thousands, or millions of specific probe products may be formed.

**[0115]** Figure 21 depicts two probe sets, one probe set for Locus 1 and one probe set for Locus 2, although as aforementioned, multiple probe sets may be designed for each genomic locus. A first probe set contains member probes 101, 102, 103. Item 101 contains label (100) type "A." Item 103 contains an affinity tag (104) which may be used for isolation and identification of the probe product. 102 may contain no modifications, such as a label or barcode. A second probe set with member probes 108, 109, 110 carries respective features as in the first probe set. However, 108 contains a label (107) of type "B," distinguishable from type "A." Item 110 contains an affinity tag (111) which may be identical to or unique from 104. Many probe sets may be designed that target "Locus 1," containing unique probe sequences but the same label type "A." Similarly, many probe sets may be designed that target "Locus 2," containing unique probe sequences but the same label type "B." In this embodiment, the affinity tags for the many probe sets for Locus 1 may be identical or unique, and the affinity tags for the many probe sets for Locus 2 may be identical or unique.

**[0116]** One or more probe sets are added to target molecules in a single vessel and exposed to sequence-specific hybridization conditions.

**[0117]** For each probe set, the three probes (e.g., 101, 102, 103) are hybridized (or attached via a similar probe-target interaction) to the target molecule (105) such there are no gaps in between the probes on the target molecule. That is, the probes from the probe set are adjacent to one another and ligation competent.

**[0118]** Ligase is added to the hybridized probes and exposed to standard ligase conditions. The ligated probes form a probe product. All (or a majority of) probe products from Locus 1 have label type "A." All probe products from Locus 2 have label type "B." Quantification of the probe products corresponding to the genomic loci 1 & 2 occurs using labels "A" and "B."

**[0119]** In some embodiments, the probe products are immobilized onto a substrate using their affinity tags. For example, if the affinity tag is a DNA sequence, the probe products may be hybridized to regions of a DNA capture array at appropriate density for subsequent imaging.

**[0120]** In some embodiments, affinity tags 104 and 111 contain unique and orthogonal sequences that allow surface-based positioning to one or more locations, which may be shared between hybridization products or not. Figures 47 and 48 show the resulting fluorescence patterns when products contain unique affinity tag sequences and the underlying substrate contains complements to each of the unique affinity tags within the same region (e.g., as the same member of an array) on a substrate. The images are of the same region of a substrate, but Figure 47 shows Cy3 labels (covalently bound to chromosome 18 product), and Figure 48 shows Alexa Fluor 647 labels (covalently bound to chromosome 21 product). Similar patterns may be generated for other assay embodiments that follow.

**[0121]** In another embodiment, affinity tags 104 and 111 contain identical sequences that allow surface-based positioning to the same region (e.g., as the same member of an array) on a substrate. That is, different products compete for the same binding sites. Figures 49 and 51 show the resulting fluorescence patterns when different products contain identical affinity tag sequences and the underlying substrate contains the complement to the affinity tag. The images are of the same location on a substrate, but Figure 49 shows Cy3 labels (covalently bound to chromosome 18 product) and Figure 51 shows Alexa Fluor 647 labels (covalently bound to chromosome 21 product). Figures 50 and 52 show zoomed-in regions of Figures 49 and 51, respectively, clearly demonstrating single-molecule resolution and individually-distinguishable labels. Similar patterns may be generated for other assay embodiments that follow.

**[0122]** In another embodiment, affinity tags 104 and 111 contain unique and orthogonal sequences that allow surface-based positioning to more than one location on a substrate. Figures 53 and 54 show the resulting fluorescence patterns

when products contain unique affinity tag sequences and the underlying substrate has one region containing the complement to one affinity tag complement, and another separate region containing the complement to the other affinity tag. The images are of two separate regions of a substrate, with each region containing a single affinity tag complement as previously described. Figure 53 shows Cy3 labels (covalently bound to chromosome 21 product), and Figure 54 shows Alexa Fluor 647 labels (covalently bound to chromosome 18 product). Similar patterns may be generated for other assay embodiments that follow.

**[0123]** One feature of this invention according to some embodiments is that specificity is achieved through the combination of multiple adjacent probes that must be successfully ligated together in order for the probe product to be successfully formed, captured and detected. If a probe product is not successfully formed for any reason, then it cannot be isolated, or enriched for using an affinity tag and detected. For example, if probe 101 is not successfully ligated to probe 102, then the resulting product cannot be detected. Similarly, if probe 103 is not successfully ligated to probe 102, then the resulting product cannot be isolated or enriched using an affinity tag.

**[0124]** Requiring all probes from the probe set to successfully hybridize to the target molecule and successfully ligate together provides high specificity and greatly reduces issues of cross-hybridization and therefore false positive signals.

**[0125]** In this assay, specificity is achieved through sequence-specific hybridization and ligation. In a preferred embodiment, the specificity of forming probe products occurs in the reaction vessel, prior to isolating or enriching for probe products, for example immobilization onto a surface or other solid substrate. This side-steps the challenge of standard surface based hybridization (e.g., genomic microarray) in which specificity must be entirely achieved through hybridization only with long (>40bp) oligonucleotide sequences (e.g., Agilent and Affymetrix arrays).

**[0126]** The use of affinity tags allows the probe products to be immobilized on a substrate and therefore excess unbound probes to be washed away using standard methods or removed using standard methods. Therefore all or most of the labels on the surface are a part of a specifically formed probe product that is immobilized to the surface.

**[0127]** One feature of this invention according to some embodiments is that the surface capture does not affect the accuracy. That is, it does not introduce any bias. In one example, if the same affinity tag is used for probe sets from different genomic loci, with probe sets targeting each locus having a different label. Probe products from both genomic loci may be immobilized to the same location on the substrate using the same affinity tag. That is probe products from Locus 1 and Locus 2 will be captured with the same efficiency, so not introducing any locus specific bias.

**[0128]** In some embodiments, some or all of the unbound probes and/or target molecules are removed prior to surface capture using standard methods. This decreases interference between unbound probes and/or target molecules and the probe products during surface capture.

**[0129]** One feature of this invention according to some embodiments is that multiple affinity tag types may be placed in the same region of the substrate (for example, the same array spot or member of the array). This has many advantages, including placement of control or calibration markers. Figures 22-46 describe additional exemplary embodiments of this invention. These Figures do not represent all possible embodiments, and all other variations of this assay are included as a part of this invention. Additionally, all features of the embodiment described in Figure 21 are applicable to all additional other embodiments of the assay described in this application.

**[0130]** Figure 22 depicts a modification of the general procedure described in Figure 21. Figure 22 depicts two probe sets, one probe set for Locus 1 and one probe set for Locus 2, although as aforementioned, multiple probes sets may be designed for each genomic locus. 207 and 214 are target molecules corresponding to Locus 1 and Locus 2, respectively. A first probe sets contains member probes 202, 204, 206. 202 contains a label (201) of type "A." 206 contains an affinity tag (205) which may be used for isolation and identification of the probe product. A second probe set with member probes 209, 211, 231 carries respective features as in the first probe set. However, 209 contains a label (208) of type "B," distinguishable from type "A." 213 contains an affinity tag (212) which may be identical to or unique from 205. Many probe sets may be designed such that target "Locus 1," containing unique probe sequences but the same label type "A." Similarly, many probe sets may be designed that target "Locus 2," containing unique probe sequences but the same label type "B." In this embodiment, the affinity tags for the many probe sets for Locus 1 may be identical or unique or a mixture of identical and unique, and the affinity tags for the many probe sets for Locus 2 may be identical or unique or a mixture of identical and unique. In this embodiment, the probes 204 and 211 may contain one or more labels (203, 210) of type "C." Therefore, probe products will contain a combination of labels. For Locus 1, probe products will contains labels of type "A" and type "C," whereas probe products from Locus 2 will contain labels of type "B" and type "C."

**[0131]** Figure 23 depicts a modification of the general procedure described in Figure 21. Figure 23 depicts two probe sets, one probe set for Locus 1 and one probe set for Locus 2, although as aforementioned, multiple probes sets may be designed for each genomic locus. 307 and 314 are target molecules corresponding to Locus 1 and Locus 2, respectively. A first probe set contains member probes 302, 303, 305. 302 contains a label (301) of type "A." 305 contains an affinity tag (306) which may be used for isolation and identification of the probe product. A second probe set with member probes 309, 310, 312 carries respective features as in the first probe set. However, 309 contains a label (308) of type "B," distinguishable from type "A." 312 contains an affinity tag (313) which may be identical to or unique from 306. Many probe sets may designed that target "Locus 1," containing unique probe sequences but the same label type "A." Similarly,

many probe sets may be designed that target "Locus 2," containing unique probe sequences but the same label type "B." In this embodiment, the affinity tags for the many probe sets for Locus 1 may be identical or unique, and the affinity tags for the many probe sets for Locus 2 may be identical or unique. In this embodiment, the probes 305 and 312 contain one or more labels (304, 311) of type "C." Therefore, probe products will contain a combination of labels. For Locus 1, probe products will contains labels of type "A" and type "C," whereas probe products from Locus 2 will contain labels of type "B" and type "C."

**[0132]** Figure 24 depicts a modification of the general procedure described in Figure 21. Figure 24 depicts two probe sets, one probe set for Locus 1 and one probe set for Locus 2, although as aforementioned, multiple probes sets may be designed for each genomic locus. 407 and 414 are target molecules corresponding to Locus 1 and Locus 2, respectively.

**[0133]** A first probe sets contains member probes 402, 405. 402 contains a label (401) of type "A." 405 contains an affinity tag (406) which may be used for isolation and identification of the probe product.

**[0134]** A second probe set with member probes 409, 412 carries respective features as in the first probe set. However, 409 contains a label (408) of type "B," distinguishable from type "A." 412 contains an affinity tag (413) which may be identical to or unique from 406. Many probe sets may designed that target "Locus 1," containing unique probe sequences but the same label type "A." Similarly, many probe sets may be designed that target "Locus 2," containing unique probe sequences but the same label type "B." In this embodiment, the affinity tags for the many probe sets for Locus 1 may be identical or unique, and the affinity tags for the many probe sets for Locus 2 may be identical or unique.

**[0135]** In this embodiment, probes 402 and 405 hybridize to sequences corresponding to Locus 1, but there is a "gap" on the target molecule consisting of one or more nucleotides between hybridized probes 402 and 405. In this embodiment, a DNA polymerase or other enzyme may be used to synthesize a new polynucleotide species (404) that covalently joins 402 and 405. That is, the probe product formed in this example is a single contiguous nucleic acid molecule with a sequence corresponding to Locus 1, and bearing the labels and/or affinity tags above. Additionally, 404 may contain one or more labels of type "C," possibly as a result of incorporation of a one of more nucleotides bearing a label of type "C." This example also conveys to the probe product formed for Locus 2, containing probes 409 and 412. Therefore, probe products will contain a combination of labels. For Locus 1, probe products will contains labels of type "A" and type "C," whereas probe products from Locus 2 will contain labels of type "B" and type "C."

**[0136]** Figure 25 depicts a modification of the general procedure described in Figure 21. Figure 25 depicts two probe sets, one probe set for Locus 1 and one probe set for Locus 2, although as aforementioned, multiple probes sets may be designed for each genomic locus. 505 and 510 are target molecules corresponding to Locus 1 and Locus 2, respectively. A first probe sets contains member probes 502, 503. 502 contains a label (501) of type "A." 503 contains an affinity tag (504) which may be used for isolation and identification of the probe product. A second probe set with member probes 507, 508 carries respective features as in the first probe set. However, 507 contains a label (506) of type "B," distinguishable from type "A." 508 contains an affinity tag (509) which may be identical to or unique from 504. Many probe sets may designed that target "Locus 1," containing unique probe sequences but the same label type "A." Similarly, many probe sets may be designed that target "Locus 2," containing unique probe sequences but the same label type "B." In this embodiment, the affinity tags for the many probe sets for Locus 1 may be identical or unique, and the affinity tags for the many probe sets for Locus 2 may be identical or unique.

**[0137]** Figure 26 depicts a modification of the general procedure described in Figure 21. Figure 26 depicts two probe sets , one probe set for Locus 1 and one probe set for Locus 2, although as aforementioned, multiple probes sets may be designed for each genomic locus. 606 and 612 are target molecules corresponding to Locus 1 and Locus 2, respectively. A first probe sets contains member probes 602, 603. 602 contains a label (601) of type "A." 603 contains an affinity tag (605) which may be used for isolation and identification of the probe product. A second probe set with member probes 608, 609 carries respective features as in the first probe set. However, 608 contains a label (607) of type "B," distinguishable from type "A." 609 contains an affinity tag (611) which may be identical to or unique from 605. Many probe sets may designed that target "Locus 1," containing unique probe sequences but the same label type "A." Similarly, many probe sets may be designed that target "Locus 2," containing unique probe sequences but the same label type "B." In this embodiment, the affinity tags for the many probe sets for Locus 1 may be identical or unique, and the affinity tags for the many probe sets for Locus 2 may be identical or unique.

**[0138]** In this embodiment, the probes 603 and 609 contain one or more labels (604, 610) of type "C." Therefore, probe products will contain a combination of labels. For Locus 1, probe products will contains labels of type "A" and type "C," whereas probe products from Locus 2 will contain labels of type "B" and type "C."

**[0139]** Figure 27 depicts a modification of the general procedure described in Figure 21. Figure 27 depicts two probe sets for identifying various alleles of the same genomic locus. For example, for distinguishing maternal and fetal alleles, in the case of cell free DNA isolated from a pregnant woman, or for distinguishing host and donor alleles, in the case of cell free DNA from a recipient of an organ transplant. Figure 27 depicts two probe sets - one probe set for Allele 1 and one probe set for Allele 2. 706 and 707 are target molecules corresponding to Allele 1 and Allele 2, respectively. A first probe set contains member probes 702, 703, 704. 702 contains a label (701) of type "A." 704 contains an affinity tag

(705) which may be used for isolation and identification of the probe product. A second probe set with member probes 709, 703, 704 carries respective features as in the first probe set. In this embodiment, 703 and 704 are identical for both probe sets. However, 709 contains a label (708) of type "B," distinguishable from type "A." In this embodiment, 702 and 709 contain sequences that are nearly identical, and differ by only one nucleotide in the sequence. Therefore, hybridization sequences of these two probes, which are configured to hybridize to the regions for Allele 1 and Allele 2, contains complementary regions for Allele 1 (702), and Allele 2 (709). Further, the length of each hybridization domain on 702 and 709, as well as experimental hybridization conditions are designed such that probe 702 will only hybridize to Allele 1 and probe 709 will only hybridize to Allele 2. The purpose of this assay type is to accurately quantify the frequency of Allele 1 and Allele 2 in a sample.

**[0140]** Figure 28 depicts a modification of the general procedure described in Figure 21. Figure 28 depicts two probe sets for identifying various alleles of the same genomic locus. For example, for distinguishing maternal and fetal alleles, in the case of cell free DNA isolated from a pregnant woman, or for distinguishing host and donor alleles, in the case of cell free DNA from a recipient of an organ transplant. Figure 28 depicts two probe sets - one probe set for Allele 1 and one probe set for Allele 2. 807 and 810 are target molecules corresponding to Allele 1 and Allele 2, respectively. A first probe set contains member probes 802, 804, 805. 802 contains a label (801) of type "A." 805 contains an affinity tag (806) which may be used for isolation and identification of the probe product. A second probe set with member probes 809, 804, 805 carries respective features as in the first probe set. In this embodiment, 804 and 805 are identical for both probe sets. However, 809 contains a label (808) of type "B," distinguishable from type "A." In this embodiment, 802 and 809 contain sequences that are nearly identical, and differ by only one nucleotide in the sequence. Therefore, hybridization sequences of these two probes contain complementary regions for Allele 1 (802), and Allele 2 (809). Further, the length of each hybridization domain on 802 and 809, as well as experimental hybridization conditions are designed such that probe 802 will only hybridize to Allele 1 and probe 809 will only hybridize to Allele 2. The purpose of this assay type is to be able to accurately quantify the frequency of Allele 1 and Allele 2 in a sample. In this embodiment, the probe 804 contains one or more labels (803) of type "C." Therefore, probe products will contain a combination of labels. For Allele 1, probe products will contain labels of type "A" and type "C," whereas probe products from Allele 2 will contain labels of type "B" and type "C."

**[0141]** Figure 29 depicts a modification of the general procedure described in Figure 21. Figure 29 depicts two probe sets for identifying various alleles of the same genomic locus. For example, for distinguishing maternal and fetal alleles, in the case of cell free DNA isolated from a pregnant woman, or for distinguishing host and donor alleles, in the case of cell free DNA from a recipient of an organ transplant. Figure 29 depicts two probe sets, one probe set for Allele 1 and one probe set for Allele 2.

**[0142]** 907 and 910 are target molecules corresponding to Allele 1 and Allele 2, respectively. A first probe set contains member probes 902, 905. 902 contains a label (901) of type "A." Item 905 contains an affinity tag (906) which may be used for isolation and identification of the probe product. A second probe set with member probes 909, 905 carries respective features as in the first probe set. In this embodiment, 905 is identical for both probe sets. However, 909 contains a label (908) of type "B," distinguishable from type "A." In this embodiment, 902 and 909 contain sequences that are nearly identical, and differ by only one nucleotide in the sequence. Therefore, hybridization sequences of these two probes contain complementary regions for Allele 1 (902), and Allele 2 (909). Further, the length of each hybridization domain on 902 and 909, as well as experimental hybridization conditions are designed such that probe 902 will only hybridize to Allele 1 and probe 909 will only hybridize to Allele 2. The purpose of this assay type is to be able to accurately quantify the frequency of Allele 1 and Allele 2 in a sample.

**[0143]** In this embodiment, probes 902 and 905 hybridize to sequences corresponding to Allele 1, such that there is a "gap" on the target molecule consisting of one or more nucleotides between hybridized probes 902 and 905. In this embodiment, a DNA polymerase or other enzyme may be used to synthesize a new polynucleotide species (904) that covalently joins 902 and 905. That is, the probe product formed in this example is a single contiguous nucleic acid molecule with a sequence corresponding to Allele 1, and bearing the labels and/or affinity tags above. Additionally, 904 may contain one or more labels of type "C," possibly as a result of incorporation of a nucleotide bearing a label of type "C." This example also conveys to the probe product formed for Allele 2, containing probes 909 and 905.

**[0144]** Figure 30 depicts a modification of the general procedure described in Figure 21. Figure 30 depicts two probe sets for identifying various alleles of the same genomic locus. For example, for distinguishing maternal and fetal alleles, in the case of cell free DNA isolated from a pregnant woman, or for distinguishing host and donor alleles, in the case of cell free DNA from a recipient of an organ transplant. Figure 30 depicts two probe sets, one probe set for Allele 1 and one probe set for Allele 2.

**[0145]** 1006 and 1007 are target molecules corresponding to Allele 1 and Allele 2, respectively. A first probe set contains member probes 1001, 1003, 1004. 1003 contains a label (1002) of type "A." 1004 contains an affinity tag (1005) which may be used for isolation and identification of the probe product.

**[0146]** A second probe set with member probes 1001, 1009, 1004 carries respective features as in the first probe set. In this embodiment, 1001 is identical for both probe sets and 1004 is identical for both probe sets. However, 1009

contains a label (1008) of type "B," distinguishable from type "A."

**[0147]** In this embodiment, 1003 and 1009 contain sequences that are nearly identical, and differ by only one nucleotide in the sequence. Therefore, hybridization sequences of these two probes contains complementary regions for Allele 1 (1003), and Allele 2 (1009), respectively. Further, the length of each hybridization domain on 1003 and 1009, as well as experimental hybridization conditions are designed such that probe 1003 will only hybridize to Allele 1 and probe 1009 will only hybridize to Allele 2. The purpose of this assay type is to be able to accurately quantify the frequency of Allele 1 and Allele 2 in a sample. In this embodiment, the probe 1001 contains one or more labels (1000) of type "C." Therefore, probe products will contain a combination of labels. For Allele 1, probe products will contain labels of type "A" and type "C," whereas probe products from Allele 2 will contain labels of type "B" and type "C."

**[0148]** Figure 31 depicts a modification of the general procedure described in Figure 21. Figure 31 depicts two probe sets for identifying various alleles of the same genomic locus. For example, for distinguishing maternal and fetal alleles, in the case of cell free DNA isolated from a pregnant woman, or for distinguishing host and donor alleles, in the case of cell free DNA from a recipient of an organ transplant. Figure 31 depicts two probe sets - one probe set for Allele 1 and one probe set for Allele 2. 1104 and 1105 are target molecules corresponding to Allele 1 and Allele 2, respectively. A first probe set contains member probes 1101, 1102. 1101 contains a label (1100) of type "A." 1102 contains an affinity tag (1103) which may be used for isolation and identification of the probe product. A second probe set with member probes 1107, 1102 carries respective features as in the first probe set. In this embodiment, 1102 is identical for both probe sets. However, 1107 contains a label (1106) of type "B," distinguishable from type "A." In this embodiment, 1101 and 1107 contain sequences that are nearly identical, and differ by only one nucleotide in the sequence. Therefore, hybridization sequences of these two probes contains complementary regions for Allele 1 (1101), and Allele 2 (1107). Further, the length of each hybridization domain on 1101 and 1107, as well as experimental hybridization conditions are designed such that probe 1101 will only hybridize to Allele 1 and probe 1107 will only hybridize to Allele 2. The purpose of this assay type is to be able to accurately quantify the frequency of Allele 1 and Allele 2 in a sample.

**[0149]** Figure 32 depicts a modification of the general procedure described in Figure 21. Figure 32 depicts two probe sets for identifying various alleles of the same genomic locus. For example, for distinguishing maternal and fetal alleles, in the case of cell free DNA isolated from a pregnant woman, or for distinguishing host and donor alleles, in the case of cell free DNA from a recipient of an organ transplant. Figure 32 depicts two probe sets - one probe set for Allele 1 and one probe set for Allele 2. 1206 and 1207 are target molecules corresponding to Allele 1 and Allele 2, respectively. A first probe set contains member probes 1202, 1203. 1202 contains a label (1201) of type "A." 1203 contains an affinity tag (1205) which may be used for isolation and identification of the probe product. A second probe set with member probes 1209, 1203 carries respective features as in the first probe set. In this embodiment, 1203 is identical for both probe sets. However, 1209 contains a label (1208) of type "B," distinguishable from type "A." In this embodiment, 1202 and 1209 contain sequences that are nearly identical, and differ by only one nucleotide in the sequence. Therefore, hybridization sequences of these two probes contains complementary regions for Allele 1 (1202), and Allele 2 (1209). Further, the length of each hybridization domain on 1202 and 1209, as well as experimental hybridization conditions are designed such that probe 1202 will only hybridize to Allele 1 and probe 1209 will only hybridize to Allele 2. The purpose of this assay type is to be able to accurately quantify the frequency of Allele 1 and Allele 2 in a sample. In this embodiment, the probe 1203 contains one or more labels (1204) of type "C." Therefore, probe product will contain a combination of labels. For Allele 1, probe products will contain labels of type "A" and type "C," whereas probe products from Allele 2 will contain labels of type "B" and type "C."

**[0150]** Figure 33 depicts a modification of the general procedure described in Figure 21. Figure 33 depicts two probe sets, one probe set for Locus 1 and one probe set for Locus 2, although as aforementioned, multiple probe sets may be designed for each genomic locus. 1304 and 1305 are target molecules corresponding to Locus 1 and Locus 2, respectively. A first probe sets contains member probes 1301, 1302. 1301 contains a label (1300) of type "A." 1301 contains an affinity tag (1303) which may be used for isolation and identification of the probe product. A second probe set with member probes 1307, 1308 carries respective features as in the first probe set. However, 1307 contains a label (1306) of type "B," distinguishable from type "A." 1307 contains an affinity tag (1309) which may be identical to or unique from 1303. Many probe sets may be designed that target "Locus 1," containing unique probe sequences but the same label type "A." Similarly, many probe sets may be designed that target "Locus 2," containing unique probe sequences but the same label type "B." In this embodiment, the affinity tags for the many probe sets for Locus 1 may be identical or unique, and the affinity tags for the many probe sets for Locus 2 may be identical or unique. In this embodiment, the probes 1301 and 1307 have similar structures. For example, on probe 1301 there are two distinct hybridization domains, such that probe 1302 may be ligated to each end of 1301, forming a probe product consisting of a contiguous, topologically closed molecule of DNA (e.g., a circular molecule). The non-hybridizing sequence on probe 1301 may contain additional features, possibly restriction enzyme sites, or primer binding sites for universal amplification.

**[0151]** One feature of this embodiment is that all probe products are contiguous circular molecules. In this manner, probe products may be isolated from all other nucleic acids via enzymatic degradation of all linear nucleic acid molecules, for example, using an exonuclease.

**[0152]** Figure 34 depicts a modification of the general procedure described in Figure 21. Figure 34 depicts two probe sets, one probe set for Locus 1 and one probe set for Locus 2, although as aforementioned, multiple probes sets may be designed for each genomic locus. 1405 and 1406 are target molecules corresponding to Locus 1 and Locus 2, respectively. A first probe sets contains member probes 1401, 1403. 1401 contains a label (1400) of type "A." 1401 contains an affinity tag (1404) which may be used for isolation and identification of the probe product. A second probe set with member probes 1408, 1410 carries respective features as in the first probe set. However, 1408 contains a label (1407) of type "B," distinguishable from type "A." 1408 contains an affinity tag (1411) which may be identical to or unique from 1404. Many probe sets may designed that target "Locus 1," containing unique probe sequences but the same label type "A." Similarly, many probe sets may be designed that target "Locus 2," containing unique probe sequences but the same label type "B." In this embodiment, the affinity tags for the many probe sets for Locus 1 may be identical or unique, and the affinity tags for the many probe sets for Locus 2 may be identical or unique. In this embodiment, the probes 1401 and 1408 have similar structures. For example, on probe 1401 there are two distinct hybridization domains, such that probe 1403 may be ligated to each end of 1401, forming a probe product consisting of a contiguous, topologically closed molecule of DNA (e.g., a circular molecule). The non-hybridizing sequence on probe 1401 may contain additional features, possibly restriction enzyme sites, or primer binding sites for universal amplification.

**[0153]** One feature of this embodiment is that all probe products are contiguous circular molecules. In this manner, probe products may be isolated from all other nucleic acids via enzymatic degradation of all linear nucleic acid molecules, for example, using an exonuclease. In this embodiment, the probes 1403 and 1410 contain one or more labels (1402, 1409) of type "C." Therefore, probe products will contain a combination of labels. For Locus 1, probe products will contains labels of type "A" and type "C," whereas probe products from Locus 2 will contain labels of type "B" and type "C."

**[0154]** Figure 35 depicts a modification of the general procedure described in Figure 21. Figure 35 depicts two probe sets, one probe set for Locus 1 and one probe set for Locus 2, although as aforementioned, multiple probes sets may be designed for each genomic locus. 1505 and 1506 are target molecules corresponding to Locus 1 and Locus 2, respectively. A first probe sets contains member probe 1501. 1501 contains a label (1500) of type "A." 1501 contains an affinity tag (1504) which may be used for isolation and identification of the probe product. A second probe set with member probe 1508 carries respective features as in the first probe set. However, 1508 contains a label (1507) of type "B," distinguishable from type "A." 1508 contains an affinity tag (1511) which may be identical to or unique from 1504. Many probe sets may designed that target "Locus 1," containing unique probe sequences but the same label type "A." Similarly, many probe sets may be designed that target "Locus 2," containing unique probe sequences but the same label type "B." In this embodiment, the affinity tags for the many probe sets for Locus 1 may be identical or unique, and the affinity tags for the many probe sets for Locus 2 may be identical or unique. In this embodiment, the probes 1501 and 1508 have similar structures.

**[0155]** For example, on probe 1501 there are two distinct hybridization domains, such that when hybridized against a target molecule, there is a gap between the two hybridization domains. In this embodiment, a DNA polymerase or other enzyme may be used to synthesize a new polynucleotide species (1503) that covalently fills the gap between the hybridization domains of 1501. That is, the probe product formed in this example is a single, contiguous, topologically closed molecule of DNA (e.g., a circular molecule) with a sequence corresponding to Locus 1, and bearing the labels and/or affinity tags above. Additionally, 1503 may contain one or more labels of type "C," possibly as a result of incorporation of a nucleotide bearing a label of type "C." This example also conveys to the probe product formed for Locus 2, containing probe 1508. The non-hybridizing sequence on probe 1501 and probe 1508 may contain additional features, possibly restriction enzyme sites. One feature of this embodiment is that all probe products are contiguous circular molecules. In this manner, probe products may be isolated from all other nucleic acids via enzymatic degradation of all linear nucleic acid molecules, for example, using an exonuclease. Probe products will contain a combination of labels. For Locus 1, probe products will contains labels of type "A" and type "C," whereas probe products from Locus 2 will contain labels of type "B" and type "C."

**[0156]** Figure 36 depicts a modification of the general procedure described in Figure 21. Figure 36 depicts two probe sets, one probe set for Locus 1 and one probe set for Locus 2, although as aforementioned, multiple probes sets may be designed for each genomic locus. 1605 and 1606 are target molecules corresponding to Locus 1 and Locus 2, respectively.

**[0157]** A first probe sets contains member probe 1602. 1602 contains a label (1600) of type "A." 1602 contains an affinity tag (1601) which may be used for isolation and identification of the probe product.

**[0158]** A second probe set with member probe 1609 carries respective features as in the first probe set. However, 1609 contains a label (1608) of type "B," distinguishable from type "A." 1609 contains an affinity tag (1607) which may be identical to or unique from 1601. Many probe sets may designed that target "Locus 1," containing unique probe sequences but the same label type "A." Similarly, many probe sets may be designed that target "Locus 2," containing unique probe sequences but the same label type "B." In this embodiment, the affinity tags for the many probe sets for Locus 1 may be identical or unique, and the affinity tags for the many probe sets for Locus 2 may be identical or unique.

**[0159]** In this embodiment, probes 1602 and 1609 hybridize to sequences corresponding to Locus 1 or Locus 2

respectively, and a DNA polymerase or other enzyme may be used to synthesize a new polynucleotide sequence, for example 1603 in the case of Locus 1 or 1611 in the case of Locus 2. In this embodiment, 1603 and 1611 may contain one or more labels (1604) of type "C," possibly as a result of incorporation of one of more nucleotides bearing a label of type "C." This example also conveys to the probe product formed for Locus 2. Therefore, probe products will contain a combination of labels. For Locus 1, probe products will contain labels of type "A" and type "C," whereas probe products from Locus 2 will contain labels of type "B" and type "C." This embodiment results in probe products with high specificity for sequences in Locus 1 or Locus 2 respectively.

**[0160]** Figure 37 depicts a modification of the general procedure described in Figure 21. Figure 37 depicts two probe sets, one probe set for Locus 1 and one probe set for Locus 2, although as aforementioned, multiple probe sets may be designed for each genomic locus. 1704 and 1705 are target molecules corresponding to Locus 1 and Locus 2, respectively.

**[0161]** A first probe set contains member probe 1702. 1702 contains an affinity tag (1700) which may be used for isolation and identification of the probe product.

**[0162]** A second probe set with member probe 1708 carries respective features as in the first probe set. 1708 contains an affinity tag (1706) which may be identical to or unique from 1700. Many probe sets may be designed that target "Locus 1," containing unique probe sequences. Similarly, many probe sets may be designed that target "Locus 2," containing unique probe sequences. In this embodiment, the affinity tags for the many probe sets for Locus 1 may be identical or unique, and the affinity tags for the many probe sets for Locus 2 may be identical or unique.

**[0163]** In this embodiment, probes 1702 and 1708 hybridize to sequences corresponding to Locus 1 and Locus 2 respectively. The designs of each probe for Locus 1 and Locus 2 are such that the first adjacent nucleotide next to the hybridization domain contains a different nucleotide for Locus 1 than for Locus 2. In this example, the first adjacent nucleotide next to the hybridization domain of 1702 is an "A," whereas the first adjacent nucleotide next to the hybridization domain of 1708 is a "T." In this embodiment, all probes for Locus 1 shall be designed such that the first nucleotide immediately adjacent to the hybridization domain shall consist of different nucleotide(s) than the first nucleotide immediately adjacent to the hybridization domain of the probes for Locus 2. That is, by design, probe sets from Locus 1 and Locus 2 may be distinguished from one another based on the identity of the first nucleotide immediately adjacent to the hybridization domain.

**[0164]** In this embodiment, a DNA polymerase or other enzyme will be used to add at least one additional nucleotide to each of the probe sequences. In this example, the nucleotide substrates for the DNA polymerase are competent for a single addition, for example, the nucleotides may be dideoxy chain terminators. That is, only one new nucleotide shall be added to each probe sequence. In this example, the nucleotide added to probe 1702 will contain one or more labels (1703) of type "A." The nucleotide added to probe 1708 will contain one or more labels (1709) of type "B," such that the probe products for Locus 1 may be distinguished from the probe products from Locus 2.

**[0165]** Figure 38 depicts a modification of the general procedure described in Figure 21. Figure 38 depicts two probe sets, one probe set for Locus 1 and one probe set for Locus 2, although as aforementioned, multiple probe sets may be designed for each genomic locus. 1804 and 1805 are target molecules corresponding to Locus 1 and Locus 2, respectively.

**[0166]** A first probe set contains member probe 1802. 1802 contains an affinity tag (1800) which may be used for isolation and identification of the probe product.

**[0167]** A second probe set with member probe 1808 carries respective features as in the first probe set. 1808 contains an affinity tag (1806) which may be identical to or unique from 1800. Many probe sets may be designed that target "Locus 1," containing unique probe sequences. Similarly, many probe sets may be designed that target "Locus 2," containing unique probe sequences. In this embodiment, the affinity tags for the many probe sets for Locus 1 may be identical or unique, and the affinity tags for the many probe sets for Locus 2 may be identical or unique.

**[0168]** In this embodiment, probes 1802 and 1808 hybridize to sequences corresponding to Locus 1 and Locus 2 respectively. The designs of each probe for Locus 1 and Locus 2 are such that the first adjacent nucleotide next to the hybridization domain contains a different nucleotide for Locus 1 than for Locus 2. In this example, the first adjacent nucleotide next to the hybridization domain of 1802 is an "A," whereas the first adjacent nucleotide next to the hybridization domain of 1808 is a "T." In this embodiment, all probes for Locus 1 shall be designed such that the first nucleotide immediately adjacent to the hybridization domain shall consist of different nucleotide(s) than the first nucleotide immediately adjacent to the hybridization domain of the probes for Locus 2. That is, by design, probe sets from Locus 1 and Locus 2 may be distinguished from one another based on the identity of the first nucleotide immediately adjacent to the hybridization domain.

**[0169]** In this embodiment, a DNA polymerase or other enzyme will be used to add at least one additional nucleotide to each of the probe sequences. In this example, the nucleotide substrates for the DNA polymerase are competent for a single addition, perhaps because the nucleotides added to the reaction mixture are dideoxy nucleotides. That is, only one new nucleotide shall be added to each probe sequence. In this example, the nucleotide added to probe 1802 will contain one or more labels (1803) of type "A." The nucleotide added to probe 1808 will contain one or more labels (1809)

of type "B," such that the probe products for Locus 1 may be distinguished from the probe products from Locus 2.

**[0170]** In this embodiment, the probes 1802 and 1808 contain one or more labels (1801, 1806) of type "C." Therefore, probe products will contain a combination of labels. For Locus 1, probe products will contain labels of type "A" and type "C," whereas probe products from Locus 2 will contain labels of type "B" and type "C."

**[0171]** Figure 39 depicts a modification of the general procedure described in Figure 21. Figure 39 depicts two probe sets, one probe set for Locus 1 and one probe set for Locus 2, although as aforementioned, multiple probe sets may be designed for each genomic locus. 1906 and 1907 are target molecules corresponding to Locus 1 and Locus 2, respectively.

**[0172]** A first probe set contains member probe 1902. 1902 contains an affinity tag (1901) which may be used for isolation and identification of the probe product.

**[0173]** A second probe set with member probe 1910 carries respective features as in the first probe set. 1910 contains an affinity tag (1908) which may be identical to or unique from 1901. Many probe sets may be designed that target "Locus 1," containing unique probe sequences. Similarly, many probe sets may be designed that target "Locus 2," containing unique probe sequences. In this embodiment, the affinity tags for the many probe sets for Locus 1 may be identical or unique, and the affinity tags for the many probe sets for Locus 2 may be identical or unique.

**[0174]** In this embodiment, probes 1902 and 1910 hybridize to sequences corresponding to Locus 1 and Locus 2 respectively. The designs of each probe for Locus 1 and Locus 2 are such that the first adjacent nucleotide next to the hybridization domains contains a different nucleotide for Locus 1 than Locus 2. In this example, the first adjacent nucleotide next to the hybridization domain of 1902 is an "A," whereas the first adjacent nucleotide next to the hybridization domain of 1910 is a "T." In this embodiment, all probes for Locus 1 shall be designed such that the first nucleotide immediately adjacent to the hybridization domain shall consist of different nucleotide(s) than the first nucleotide immediately adjacent to the hybridization domain of the probes for Locus 2. That is, by design, probe sets from Locus 1 and Locus 2 may be distinguished from one another nucleotide on the identity of the first nucleotide immediately adjacent to the hybridization domain. A different nucleotide, not one used to distinguish probes from Locus 1 or Locus 2 shall serve as a chain terminator. In this particular example, an "A" nucleotide on a target molecule is used to distinguish probes for Locus 1 and a "T" nucleotide is used to distinguish probes for Locus 2. In this example, a "C" nucleotide may serve as a chain terminator. In this case, a "C" nucleotide will be added to the assay not is not capable of chain elongation (for example, a dideoxy C). One additional constraint is that the probe sequences are designed such that there are no instances of an identifying nucleotide for Locus 2 present on 1906 in between the distinguishing nucleotide for Locus 1 and the chain terminating nucleotide. In this example, there will be no "T" nucleotides present on 1906 after the hybridization domain of 1902 and before the G, which will pair with the chain terminator C.

**[0175]** In this embodiment, DNA polymerase or a similar enzyme will be used to synthesize new nucleotide sequences, and the nucleotide added at the distinguishing nucleotide location for Locus 1 will contain one or more labels (1903) of type "A." The nucleotide added at the distinguishing nucleotide location for Locus 2 will contain 1 or more labels (1911) of type "B," such that the probe products for Locus 1 may be distinguished from the probe products from Locus 2. In this embodiment, the nucleotide added at the chain terminating position will contain one or more labels (1912) of type "C." Therefore, probe products will contain a combination of labels. For Locus 1, probe products will contain labels of type "A" and type "C," whereas probe products from Locus 2 will contain labels of type "B" and type "C."

**[0176]** In another embodiment, the chain terminator may contain no label. In this embodiment, a fourth nucleotide may be added to the assay that contains one or more labels of type "C." This fourth nucleotide does not pair with the identifying nucleotide for Allele 1 (in this example, A), does not pair with the identifying nucleotide for Allele 2 (in this example, T), does not pair with the chain terminating nucleotide (in this example G). In this example, the fourth nucleotide that would bear one or more labels of type "C" is G, and will pair with C locations on 1906 and 1907. Therefore, probe products will contain a combination of labels. For Locus 1, probe products will contain labels of type "A" and type "C," whereas probe products from Locus 2 will contain labels of type "B" and type "C."

**[0177]** Figure 40 depicts a modification of the general procedure described in Figure 21. Figure 40 depicts two probe sets, one probe set for Locus 1 and one probe set for Locus 2, although as aforementioned, multiple probe sets may be designed for each genomic locus. 2005 and 2006 are target molecules corresponding to Locus 1 and Locus 2, respectively.

**[0178]** A first probe set contains member probe 2001. 2001 contains an affinity tag (2000) which may be used for isolation and identification of the probe product.

**[0179]** A second probe set with member probe 2008 carries respective features as in the first probe set. 2008 contains an affinity tag (2007) which may be identical to or unique from 2000. Many probe sets may be designed that target "Locus 1," containing unique probe sequences. Similarly, many probe sets may be designed that target "Locus 2," containing unique probe sequences. In this embodiment, the affinity tags for the many probe sets for Locus 1 may be identical or unique, and the affinity tags for the many probe sets for Locus 2 may be identical or unique.

**[0180]** In this embodiment, probes 2001 and 2008 hybridize to sequences corresponding to Locus 1 and Locus 2 respectively. The designs of each probe for Locus 1 and Locus 2 are such that there are one or more instances of a

distinguishing nucleotide (in this example, "A" is a distinguishing nucleotide for Locus 1 and "T" is a distinguishing nucleotide for Locus 2) followed by a chain terminating nucleotide (in this example "G") adjacent to the hybridization domain of the probes. Importantly there will be no instances of the distinguishing nucleotide for Locus 2 (in this example, "T") present in between the hybridization domain of 2001 on 2005 and the chain terminating nucleotide on 2005. Similarly, there will be no instance of the distinguishing nucleotide for Locus 1 (in this example, "A") present in between the hybridization domain of 2008 on 2006 and the chain terminating nucleotide on 2006.

**[0181]** In this embodiment, DNA polymerase or a similar enzyme will be used to synthesize new nucleotide sequences (2004, 2011) until the addition of a chain terminating nucleotide, one possible example would be a dideoxy C. In this embodiment, the nucleotides added at the distinguishing nucleotide locations for Locus 1 will contain one or more labels (2003) of type "A." The nucleotides added at the distinguishing nucleotide locations for Locus 2 will contain 1 or more labels (2010) of type "B," such that the probe products for Locus 1 may be clearly distinguished from the probe products from Locus 2.

**[0182]** Figure 41 depicts a modification of the general procedure described in Figure 21. Figure 41 depicts two probe sets, one probe set for Locus 1 and one probe set for Locus 2, although as aforementioned, multiple probe sets may be designed for each genomic locus. 2105 and 2106 are target molecules corresponding to Locus 1 and Locus 2, respectively.

**[0183]** A first probe set contains member probe 2102. 2102 contains an affinity tag (2100) which may be used for isolation and identification of the probe product.

**[0184]** A second probe set with member probe 2109 carries respective features as in the first probe set. 2109 contains an affinity tag (2107) which may be identical to or unique from 2100. Many probe sets may be designed that target "Locus 1," containing unique probe sequences. Similarly, many probe sets may be designed that target "Locus 2," containing unique probe sequences. In this embodiment, the affinity tags for the many probe sets for Locus 1 may be identical or unique, and the affinity tags for the many probe sets for Locus 2 may be identical or unique.

**[0185]** In this embodiment, probes 2102 and 2109 hybridize to sequences corresponding to Locus 1 and Locus 2 respectively. The designs of each probe for Locus 1 and Locus 2 are such that there are one or more instances of a distinguishing nucleotide (in this example, "A" is a distinguishing nucleotide for Locus 1 and "T" is a distinguishing nucleotide for Locus 2) followed by a chain terminating nucleotide (in this example "G") adjacent to the hybridization domain of the probes. Importantly there will be no instances of the distinguishing nucleotide for Locus 2 (in this example, "T") present in between the hybridization domain of 2102 on 2105 and the chain terminating nucleotide on 2105. Similarly, there will be no instance of the distinguishing nucleotide for Locus 1 (in this example, "A") present in between the hybridization domain of 2109 on 2106 and the chain terminating nucleotide on 2106.

**[0186]** In this embodiment, DNA polymerase or a similar enzyme will be used to synthesize new nucleotide sequences (2104, 2110) until the addition of a chain terminating nucleotide, one possible example would be a dideoxy C. In this embodiment, the nucleotides added at the distinguishing nucleotide locations for Locus 1 will contain one or more labels (2103) of type "A." The nucleotides added at the distinguishing nucleotide locations for Locus 2 will contain 1 or more labels (2110) of type "B," such that the probe products for Locus 1 may be clearly distinguished from the probe products from Locus 2.

**[0187]** In this embodiment, the probes 2102 and 2109 contain one or more labels (2101, 2108) of type "C." Therefore, probe products will contain a combination of labels. For Locus 1, probe products will contain labels of type "A" and type "C," whereas probe products from Locus 2 will contain labels of type "B" and type "C."

**[0188]** Figure 42 depicts a modification of the general procedure described in Figure 21. Figure 42 depicts two probe sets for identifying various alleles of the same genomic locus. For example, for distinguishing maternal and fetal alleles, in the case of cell free DNA isolated from a pregnant woman, or for distinguishing host and donor alleles, in the case of cell free DNA from a recipient of an organ transplant. Figure 42 depicts two probe sets - one probe set for Allele 1 and one probe set for Allele 2. 2203 and 2204 are target molecules corresponding to Allele 1 and Allele 2, respectively.

**[0189]** A first probe set contains member probe 2201. 2201 contains an affinity tag (2200) which may be used for isolation and identification of the probe product. In this embodiment, the probe sets used for identification of the two different alleles are the same. That is, the probe set for Allele 2 consists of member probe 2201. In this embodiment, probe 2201 hybridizes to a sequence corresponding to Allele 1 and Allele 2 respectively in Figure 42. The design of probe 2201 is such that the first adjacent nucleotide next to the hybridization domain contains a different nucleotide for Allele 1 than Allele 2. In other words, the first nucleotide adjacent to the hybridization domain may be a single nucleotide polymorphism, or SNP. In this example, the first adjacent nucleotide on 2203 next to the hybridization domain of 2201 is an "A," whereas the first adjacent nucleotide on 2204 next to the hybridization domain of 2201 is a "T." That is, probe products from Allele 1 and Allele 2 may be distinguished from one another based on the identity of the first nucleotide immediately adjacent to the hybridization domain.

**[0190]** In this embodiment, a DNA polymerase or other enzyme will be used to add at least one additional nucleotide to each of the probe sequences. In this example, the nucleotide substrates for the DNA polymerase are competent for a single addition, perhaps because the nucleotides added to the reaction mixture are dideoxy nucleotides. That is, only

one new nucleotide shall be added to each probe sequence. In this example, the nucleotide added to probe 2201 for Allele 1 will contain one or more labels (2202) of type "A." The nucleotide added to probe 2201 for Allele 2 will contain one or more labels (2205) of type "B," such that the probe products for Allele 1 may be clearly distinguished from the probe products from Allele 2. That is, the probe product for Allele 1 consists of probe 2201 plus one additional nucleotide bearing one or more labels of type "A," and the probe products for Allele 2 consists of probe 2201 plus one additional nucleotide bearing one or more labels of type "B."

**[0191]** Figure 43 depicts a modification of the general procedure described in Figure 21. Figure 43 depicts two probe sets for identifying various alleles of the same genomic locus. For example, for distinguishing maternal and fetal alleles, in the case of cell free DNA isolated from a pregnant woman, or for distinguishing host and donor alleles, in the case of cell free DNA from a recipient of an organ transplant. Figure 43 depicts two probe sets - one probe set for Allele 1 and one probe set for Allele 2. 2304 and 2305 are target molecules corresponding to Allele 1 and Allele 2, respectively.

**[0192]** A first probe sets contains member probe 2302. 2302 contains an affinity tag (2300) which may be used for isolation and identification of the probe product. In this embodiment, the probe sets used for identification of the two different alleles are the same. That is, the probe set for Allele 2 consists of member probe 2302. In this embodiment, probe 2302 hybridizes to a sequence corresponding to Allele 1 and Allele 2 respectively in Figure 43. The design of probe 2302 is such that the first adjacent nucleotide next to the hybridization domains contains a different nucleotide for Allele 1 than Allele 2. In other words, the first nucleotide adjacent to the hybridization domain may be a single nucleotide polymorphism, or SNP. In this example, the first adjacent nucleotide on 2304 next to the hybridization domain of 2302 is an "A," whereas the first adjacent nucleotide on 2305 next to the hybridization domain of 2302 is a "T." That is, probe products from Allele 1 and Allele 2 may be distinguished from one another based on the identity of the first nucleotide immediately adjacent to the hybridization domain.

**[0193]** In this embodiment, a DNA polymerase or other enzyme will be used to add at least one additional nucleotide to each of the probe sequences. In this example, the nucleotide substrates for the DNA polymerase are competent for a single addition, perhaps because the nucleotides added to the reaction mixture are dideoxy nucleotides. That is, only one new nucleotide shall be added to each probe sequence. In this example, the nucleotide added to probe 2302 for Allele 1 will contain one or more labels (2303) of type "A." The nucleotide added to probe 2302 for Allele 2 will contain one or more labels (2306) of type "B," such that the probe products for Allele 1 may be clearly distinguished from the probe products from Allele 2. That is, the probe product for Allele 1 consists of probe 2302 plus one additional nucleotide bearing one or more labels of type "A," and the probe products for Allele 2 consists of probe 2302 plus one additional nucleotide bearing one or more labels of type "B."

**[0194]** In this embodiment, the probes 2302 contain one or more labels (2301) of type "C." Therefore, probe products will contain a combination of labels. For Allele 1, probe products will contains labels of type "A" and type "C," whereas probe products from Allele 2 will contain labels of type "B" and type "C."

**[0195]** Figure 44 depicts a modification of the general procedure described in Figure 21. Figure 44 depicts two probe sets for identifying various alleles of the same genomic locus. For example, for distinguishing maternal and fetal alleles, in the case of cell free DNA isolated from a pregnant woman, or for distinguishing host and donor alleles, in the case of cell free DNA from a recipient of an organ transplant. Figure 44 depicts two probe sets - one probe set for Allele 1 and one probe set for Allele 2. 2405 and 2406 are target molecules corresponding to Allele 1 and Allele 2, respectively.

**[0196]** A first probe sets contains member probe 2401. 2401 contains an affinity tag (2400) which may be used for isolation and identification of the probe product. In this embodiment, the probe sets used for identification of two different alleles are the same. That is, the probe set for Allele 2 consists of member probe 2401. In this embodiment, probe 2401 hybridizes to a sequence corresponding to Allele 1 and Allele 2 respectively in Figure 44. The design of probe for 2401 is such that the first adjacent nucleotide next to the hybridization domains contains a different nucleotide for Allele 1 than Allele 2. In other words, the first nucleotide adjacent to the hybridization domain may be a single nucleotide polymorphism, or SNP. In this example, the first adjacent nucleotide on 2405 next to the hybridization domain of 2401 is an "A," whereas the first adjacent nucleotide on 2406 next to the hybridization domain of 2401 is a "T." That is, probe products from Allele 1 and Allele 2 may be distinguished from one another based on the identity of the first nucleotide immediately adjacent to the hybridization domain.

**[0197]** In this embodiment, a DNA polymerase or other enzyme will be used to add at least one additional nucleotide to each of the probe sequences. In this example, the nucleotide added to probe 2401 for Allele 1 will contain one or more labels (2402) of type "A." The nucleotide added to probe 2401 for Allele 2 will contain one or more labels (2407) of type "B," such that the probe products for Locus 1 may be clearly distinguished from the probe products from Locus 2. That is, the probe product for Allele 1 contains probe 2401 plus an additional nucleotide bearing one or more labels of type "A," and the probe product for Allele 2 contains probe 2401 plus an additional nucleotide bearing one or more labels of type "B." A different nucleotide, not one used to distinguish Allele 1 from Allele 2 shall serve as a chain terminator. In this particular example, an "A" nucleotide on a target molecule is used to identify Allele 1 and a "T" nucleotide is used to identify Allele 2. In this example, a "C" nucleotide may serve as a chain terminator. In this case, a "C" nucleotide will be added to the assay that is not is not capable of chain elongation (for example, a dideoxy C). One additional constraint

is that the probe sequences are designed such that there are no instances of an identifying nucleotide for Allele 2 is present on 2405 in between the distinguishing nucleotide for Allele 1 and the chain terminating nucleotide. In this example, there will be no "T" nucleotides present on 2405 after the hybridization domain of 2401 and before a G, which will pair with the chain terminator C.

5 **[0198]** In this embodiment, DNA polymerase or a similar enzyme will be used to synthesize new nucleotide sequences, and the nucleotide added at the distinguishing nucleotide location for Allele 1 will contain one or more labels (2402) of type "A." The nucleotide added at the distinguishing nucleotide location for Allele 2 will contain 1 or more labels (2407) of type "B," such that the probe products for Allele 1 may be clearly distinguished from the probe products from Allele 2. In this embodiment, the nucleotide added at the chain terminating position will contain one or more labels (2403) of type "C." Therefore, probe products will contain a combination of labels. For Allele 1, probe products will contain labels of type "A" and type "C," whereas probe products from Allele 2 will contain labels of type "B" and type "C."

10 **[0199]** Figure 45 depicts a modification of the general procedure described in Figure 21. Figure 45 depicts two probe sets for identifying various alleles of the same genomic locus. For example, for distinguishing maternal and fetal alleles, in the case of cell free DNA isolated from a pregnant woman, or for distinguishing host and donor alleles, in the case of cell free DNA from a recipient of an organ transplant. Figure 45 depicts two probe sets - one probe set for Allele 1 and one probe set for Allele 2. 2505 and 2506 are target molecules corresponding to Allele 1 and Allele 2, respectively.

15 **[0200]** A first probe sets contains member probe 2501. 2501 contains an affinity tag (2500) which may be used for isolation and identification of the probe product. In this embodiment, the probe sets used for identification of two different alleles are the same. That is, the probe set for Allele 2 consists of member probe 2501. In this embodiment, probe 2501 hybridizes to a sequence corresponding to Allele 1 and Allele 2 respectively in Figure 45. The design of probe for 2501 is such that the first adjacent nucleotide next to the hybridization domains contains a different nucleotide for Allele 1 than Allele 2. In other words, the first nucleotide adjacent to the hybridization domain may be a single nucleotide polymorphism, or SNP. In this example, the first adjacent nucleotide on 2505 next to the hybridization domain of 2501 is an "A," whereas the first adjacent nucleotide on 2506 next to the hybridization domain of 2501 is a "T." That is, probe products from Allele 1 and Allele 2 may be distinguished from one another based on the identity of the first base immediately adjacent to the hybridization domain.

20 **[0201]** In this embodiment, a DNA polymerase or other enzyme will be used to add at least one additional nucleotide to each of the probe sequences. In this example, the nucleotide added to probe 2501 for Allele 1 will contain one or more labels (2502) of type "A." The nucleotide added to probe 2501 for Allele 2 will contain one or more labels (2507) of type "B," such that the probe products for Locus 1 may be clearly distinguished from the probe products from Locus 2. That is, the probe product for Allele 1 contains probe 2501 plus an additional nucleotide bearing one or more labels of type "A," and the probe product for Allele 2 contains probe 2501 plus an additional nucleotide bearing one or more labels of type "B." A different nucleotide, not one used to distinguish Allele 1 from Allele 2 shall serve as a chain terminator. In this particular example, an "A" nucleotide on a target molecule is used to identify Allele 1 and a "T" nucleotide is used to identify Allele 2. In this example, a "C" nucleotide may serve as a chain terminator. In this case, a "C" nucleotide will be added to the assay that is not capable of chain elongation (for example, a dideoxy C). One additional constraint is that the probe sequences are designed such that no instances of an identifying nucleotide for Allele 2 are present on 2505 in between the distinguishing nucleotide for Allele 1 and the chain terminating nucleotide. In this example, there will be no "T" nucleotides present on 2505 after the hybridization domain of 2501 and before a G, which will pair with the chain terminator C.

25 **[0202]** In this embodiment, DNA polymerase or a similar enzyme will be used to synthesize new nucleotide sequences, and the nucleotide added at the distinguishing nucleotide location for Allele 1 will contain one or more labels (2502) of type "A." The nucleotide added at the distinguishing nucleotide location for Allele 2 will contain 1 or more labels (2507) of type "B," such that the probe products for Allele 1 may be clearly distinguished from the probe products from Allele 2. In this embodiment, a fourth nucleotide may be added to the assay that contains one or more labels (2508, 2503) of type "C." This fourth nucleotide does not pair with the identifying nucleotide for Allele 1 (in this example, A), does not pair with the identifying nucleotide for Allele 2 (in this example, T), does not pair with the chain terminating nucleotide (in this example G). In this example, the fourth nucleotide that would bear one or more labels of type "C" is G, and will pair with C locations on 2505 and 2506. Therefore, probe products will contain a combination of labels. For Allele 1, probe products will contain labels of type "A" and type "C," whereas probe products from Allele 2 will contain labels of type "B" and type "C."

30 **[0203]** Figure 46 depicts a modification of the general procedure described in Figure 21. Figure 46 depicts two probe sets for identifying various alleles of the same genomic locus. For example, for distinguishing maternal and fetal alleles, in the case of cell free DNA isolated from a pregnant woman, or for distinguishing host and donor alleles, in the case of cell free DNA from a recipient of an organ transplant. Figure 46 depicts two probe sets - one probe set for Allele 1 and one probe set for Allele 2. 2605 and 2606 are target molecules corresponding to Allele 1 and Allele 2, respectively. A first probe set contains member probe 2602. 2602 contains a label (2601) of type "A." 2602 contains an affinity tag (2600) which may be used for isolation and identification of the probe product.

**[0204]** A second probe set with member probe 2609 carries respective features as in the first probe set. However, 2609 contains a label (2608) of type "B," distinguishable from type "A." 2609 contains an affinity tag (2607) which may be identical to or unique from 2600.

**[0205]** In this embodiment, 2602 and 2609 contain sequences that are nearly identical, and differ by only one nucleotide in the sequence. Therefore, hybridization sequences of these two probes are complementary to Allele 1 (2605), or Allele 2 (2606). Further, the length of each hybridization domain on 2602 and 2609, as well as experimental hybridization conditions are designed such that probe 2602 will only hybridize to Allele 1 and probe 2609 will only hybridize to Allele 2. The purpose of this assay type is to be able to accurately quantify the frequency of Allele 1 and Allele 2 in a sample.

**[0206]** In this embodiment, DNA polymerase or other enzyme may be used to synthesize a new polynucleotide sequence, for example 2604 in the case of Allele 1 or 2611 in the case of Allele 2. In this embodiment, 2604 and 2611 may contain one or more labels (2603, 2610) of type "C," possibly as a result of incorporation of a one of more nucleotides bearing a label of type "C." Therefore, probe products will contain a combination of labels. For Allele 1, probe products will contain labels of type "A" and type "C," whereas probe products from Allele 2 will contain labels of type "B" and type "C." This embodiment results in probe products with high specificity for sequences in Allele 1 or Allele 2 respectively.

**[0207]** Figures 55-58 illustrate a modification of the general procedure described with respect to Figures 21-46. Figure 55 depicts two probe sets; one probe set for Locus 1 and one probe set for Locus 2 - although as aforementioned, multiple probes sets may be designed for each genomic locus. The left arm of the Locus 1 probe set consists of a forward priming sequence, an affinity tag sequence and a homolog to Locus 1 sequence. The right arm of the Locus 1 probe set consists of a homolog to Locus 1 sequence and a reverse priming sequence for labeling the Locus 1 probe set with label A. The left arm of the Locus 2 probe set consists of a forward priming sequence, an affinity tag sequence and a homolog to Locus 2 sequence. The right arm of the Locus 2 probe set consists of a homolog to Locus 2 sequence and a reverse priming sequence for labeling the Locus 2 probe set with label B. The forward priming sequence and the affinity tag sequence are identical for the probe sets for both Locus 1 and Locus 2. The homologous sequences are specific to a single genomic locus. Locus homologous sequences for each probe set are immediately adjacent to one another such that when they hybridize to their target loci, they immediately abut one another and thus may be ligated to form one continuous molecule. The reverse priming sequence is specific to the label (e.g., label A or label B) to be used in labeling probe products for a particular locus for a particular affinity tag sequence.

**[0208]** Figure 56 depicts the procedural workflow that would be applied to the collection of probe sets, such as those probe sets illustrated in Figure 55. This depiction is based on one probe set for one genomic locus (e.g., the probe set for Locus 1 shown in Figure 55). In Step 1, the collection of probe sets is mixed with purified cell-free DNA. In Step 2, the locus specific sequences in each probe set hybridize to their corresponding homologous sequences in the cell-free DNA sample. In Step 3, a ligase enzyme is added to catalyze the formation of a phosphodiester bond between the 3' base on the left arm homolog and the 5' arm of the right homolog, closing the nick between the two arms and thus forming one continuous molecule which is the probe product. In Step 4, modified primers and PCR reaction components (*Taq* polymerase, dNTPs, and reaction buffer) are added to amplify the ligated probe product. The Forward Primer is modified in that it has a 5' phosphate group that makes it a preferred template for the Lambda exonuclease used in Step 6 and the Reverse Primer is modified in that it contains the label (blue circle) that is specific to probe products for a particular locus for a particular affinity tag. In Step 5, the probe product is PCR amplified to yield a double-stranded PCR product in which the forward strand contains a 5' phosphate group and the reverse strand contains a 5' label. In Step 6, Lambda exonuclease is added to digest the forward strand in a 5' to 3' direction - the 5' phosphate group on the forward strand makes it a preferred template for Lambda exonuclease digestion. The resulting material is single-stranded (reverse strand only) with a 5' label. This represents the labeled target material for hybridization to a microarray or monolayer.

**[0209]** Figure 57 depicts a modified version of the procedural workflow illustrated in Figure 56. In this embodiment the left arm of each probe set contains a terminal biotin molecule as indicated by a "B" in Steps 1 to 6 of the Figure. This biotinylation enables the purification of the collection of probe products after completion of the hybridization-ligation reaction and prior to the PCR amplification. The workflow for this embodiment is identical to that described in Figure 57 for Steps 1 to 3. In Step 4, streptavidin-coated magnetic beads are added to the hybridization-ligation reaction. The biotin molecule contained in the probe products will bind the products to the streptavidin. In Step 5, the magnetic beads are washed to remove the non-biotinylated DNA (cell-free genomic DNA and right arm oligonucleotides), resulting in a purified probe product. Steps 6 to 9 are performed in the same manner as described for Steps 4 to 7 in Figure 56.

**[0210]** Figure 58 provides an example of how probe products for Locus 1 and Locus 2 may be labeled with different label molecules. In Figure 58A, Locus 1 probe products are labeled with label A (green) and Locus 2 probe products are labeled with label B (red) in one PCR amplification reaction. Probe products for both loci contain affinity tag sequence A. In Figure 58B, the mixture of differentially labeled probe products is hybridized to a microarray location in which the capture probe sequence is complementary to the affinity tag A sequence. In Figure 58C, the microarray location is imaged and the number of molecules of label A and label B counted to provide a relative measure of the levels of Locus 1 and Locus 2 present in the sample.

**[0211]** Figure 59 provides evidence that probe products representing a multitude of genomic locations for one locus may be generated in a ligase enzyme specific manner using the hybridization-ligation process. Eight probe sets, each consisting of a left arm and right arm component as described in Figure 55 and, containing homologs to eight chromosome 18 locations were hybridized to synthetic oligonucleotide templates (about 48 nucleotides) and ligated using a ligase enzyme to join the left and right arms for each. Reaction products were analyzed using denaturing polyacrylamide gel electrophoresis. Gel lane 1 contains a molecular weight ladder to indicate DNA band sizes. Lanes 2 to 9 contain hybridization-ligation reaction products for the eight chromosome 18 probe sets. A DNA band of about 100 nucleotides, representing the probe product of the about 60 nucleotide left arm and the about 40 nucleotide right arm, is present in each of lanes 2 to 9. Lanes 10 and 11 contain negative control reactions to which no ligase enzyme was added. No DNA band of about 100 nucleotides is present in lanes 10 and 11.

**[0212]** Figure 60 provides data indicating that probe sets may be used to detect relative changes in copy number state. A mixture of eight probe sets containing homologs to eight distinct chromosome X locations was used to assay the cell lines containing different numbers of chromosome X indicated in Table 1.

**Table 1:** Cell lines containing different copy numbers of chromosome X

Coriell Cell Line ID	Number of copies of chromosome X
NA12138	1
NA13783	2
NA00254	3
NA01416	4
NA06061	5

**[0213]** Quantitative PCR was used to determine the amount of probe product present for each cell line following the hybridization-ligation and purification processes described in Figure 57 (Steps 1 to 5). As illustrated by Figure 60A, the copy number state measured for the various cell lines followed the expected trend indicated in Table 1. For example, qPCR indicated a copy number state of less than two for NA12138, which has one copy of chromosome X. The measured copy number state for NA00254 (three copies of X) was greater than two, for NA01416 (four copies of X) was greater than three, and for NA06061 (five copies of X) was greater than four. The responsiveness of the process in detecting differences in copy number state is further illustrated by Figure 60B in which the measured copy number state is plotted against the theoretical copy number state.

**[0214]** Figure 61 provides evidence that mixtures of probe products may be used to generate quantitative microarray data as described in Figures 56 and 57.

**[0215]** Figure 61A depicts representative fluorescence images of two array spots in two orthogonal imaging channels (Alexa 488: green, Alexa 594; red). A region of interest (ROI) is automatically selected (large circle), with any undesired bright contaminants being masked from the image (smaller outlined regions within the ROI). Single fluorophores on single hybridized assay products are visualized as small punctate features within the array spot. (i) A "Balanced" spot (representing genomic targets input at a 1:1 concentration ratio to the assay) imaged in the green channel and (ii) the same spot imaged in the red channel, (iii) An "Increased" spot (representing genomic targets input at a > 1:1 concentration ratio to the assay) imaged in the green channel and (iv) the same spot imaged in the red channel.

**[0216]** Figure 61B presents raw counts of the detected fluorophores in two channels for five spots each of the "Balanced" and "Increased" conditions. Despite some variation in the absolute number of fluors, the numbers in the two channels track closely for the "Balanced" case, but demonstrate clear separation in the "Increased" case.

**[0217]** Figure 61C presents calculated ratio values for number of fluors in the green channel divided by the number of fluors in the red channel, for the five spots from each of the "Balanced" and "Increased" conditions. The "Balanced" case centers about a ratio of 1.0 and the "Increased" case is at an elevated ratio. Considering the "Balanced" case as comparing two balanced genomic loci and the "Increased" case as one where one locus is increased relative to the other, we may calculate the confidence of separation of the two conditions using an independent, 2-group T-test, yielding a p-value of  $8 \times 10^{-14}$ .

**[0218]** Figure 62 illustrates a modification of the general procedure described in Figures 55 to 58. In this embodiment, a second probe set, Probe Set B is designed for each genomic location such that the genome homolog sequences in Probe Set B are a reverse complement of the genome homolog sequences in Probe Set A. Probe Set A will hybridize to the reverse strand of the genomic DNA and Probe Set B will hybridize to the forward strand of the genomic DNA. This embodiment will provide increased sensitivity relative to the embodiment described in Figures 55 to 58 as it will yield approximately double the number of probe products per locus.

[0219] Figure 63 illustrates a modification to the general procedure described in Figure 57. In this embodiment, the Reverse Primer used in Step 6 is additionally modified in that the four bonds linking the first five nucleotides in the oligonucleotide sequence are phosphorothioate bonds. This modification will result in all PCR products generated during PCR amplification (Step 7) having a phosphorothioate modification on the 5' end. This modification will protect the reverse strand from any digestion that might occur during the treatment with Lambda exonuclease in Step 8.

[0220] Although the 5' phosphate group on the forward strand makes it a preferred template for Lambda exonuclease digestion, the reverse strand may still have some vulnerability to digestion. Phosphorothioate modification of the 5' end of the reverse strand will reduce its vulnerability to Lambda exonuclease digestion.

[0221] Figure 64 illustrates a modification of the general procedure described in Figures 55 to 58. In this embodiment, PCR amplification of the probe product is replaced with linear amplification by adding the Reverse Primer but no Forward Primer to the amplification reaction in Step 6. If only the Reverse Primer is present the amplification product will be single stranded - the reverse strand with a label of the 5' end. As the amplification product is already single-stranded, it does not require further processing before hybridization to a microarray, i.e., Lambda exonuclease digestion may be omitted. As a forward primer is not used in this embodiment, it is unnecessary for the left arm of the probe set to contain a forward priming sequence. The left arm would consist of an affinity tag sequence and a locus homolog sequence only as illustrated in Figure 64.

[0222] A further embodiment of the general procedure described in Figures 55 to 58 is one in which the single ligation reaction process in Step 3 is replaced with a cycled ligation reaction process. This is accomplished by replacing the thermolabile ligase enzyme (e.g., T4 ligase) used to catalyze the ligation reaction with a thermostable ligase (e.g., *Taq* ligase). When a thermostable ligase is used, the hybridization-ligation reaction may be heated to a temperature that will melt all DNA duplexes (e.g., 95 °C) after the initial cycle of hybridization and ligation has occurred. This will make the genomic template DNA fully available for another probe set hybridization and ligation. Subsequent reduction of the temperature (e.g., to 45 °C) will enable this next hybridization and ligation event to occur. Each thermocycling of the hybridization and ligation reaction between a temperature that will melt DNA duplexes and one that will allow hybridization and ligation to occur will linearly increase the amount of probe product yielded from the reaction. If the reaction is exposed to 30 such cycles, up to 30 times the amount of probe product will be yielded than from a process in which a single ligation reaction is used.

[0223] Figure 65 depicts a further embodiment of the modified procedure described in Figure 62. This embodiment takes advantage of the ligase chain reaction (LCR) in combining the presence of the reverse complement for each probe set with the use of a thermostable ligase to enable a cycled ligation reaction in which the product is exponentially amplified. Figure 65 depicts two probe sets, Probe Set A and Probe Set B for one locus; where the genome homolog sequences in Probe Set B are the reverse complement of the genome homolog sequences in Probe Set A. The 5' arm of each Probe Set consists of an affinity tag sequence and a homolog while the 3' arm of each Probe Set consists of a homolog sequence with a label attached. In the first cycle of a thermocycled reaction, genomic DNA will be the only template available to enable hybridization and ligation to occur to generate a probe product as illustrated in Figure 65A. However in the second cycle, Probe Product B generated in the first cycle will act as an additional template for Probe Set A and likewise Probe Product A generated in the first cycle will act as an additional template for Probe Set B as illustrated in Figure 65B. In this same manner, the probe products from each successive cycle will act as template for probe set hybridization and ligation in the next cycle. This process would eliminate the need for PCR amplification of the probe product which may be directly used as microarray target.

[0224] Another embodiment of the procedure depicted in Figure 65 is one which employs LCR but uses probe sets that have the structure described in Figure 55, i.e., both left and right arms are flanked by priming sequences, the left arm contains a biotin molecule and the right arm does not contain a label. After completion of LCR, the probe products are purified using magnetic beads (optional) and then PCR amplified and microarray target prepared as illustrated in Figures 56 and 57.

[0225] Figure 66 depicts yet another embodiment of the procedure depicted in Figure 65. The 5' arm of each Probe Set consists of an affinity tag sequence and a homolog while the 3' arm of each Probe Set consists of a homolog sequence and a priming sequence without a label attached as illustrated in Figure 66A. After completion of the LCR, the probe product may be purified. The LCR product would then be amplified in a linear manner by the addition of a single primer that has a label attached, along with reaction components (*Taq* polymerase, dNTPs, and reaction buffer) as illustrated in Figure 66B. The product of this amplification would be single-stranded (reverse strand only) with a 5' label as illustrated in Figure 66C. Consequently it would not be necessary to treat it with Lambda exonuclease but rather it could instead be directly used as microarray target.

[0226] In another aspect, the genetic variation determined by the methods described herein indicates presence or absence of cancer, pharmacokinetic variability, drug toxicity, transplant rejection, or aneuploidy in the subject. In another aspect, the determined genetic variation indicates presence or absence of cancer. Accordingly, the methods described herein may be performed to diagnose cancer.

[0227] A significant challenge in oncology is the early detection of cancer. This is particularly true in cancers that are

hard to image or biopsy (e.g., pancreatic cancer, lung cancer). Cell free tumor DNA (tumor cfDNA) in a patient's blood offers a method to non-invasively detect a tumor. These may be solid tumors, benign tumors, micro tumors, liquid tumors, metastasis or other somatic growths. Detection may be at any stage in the tumor development, though ideally early (Stage I or Stage II). Early detection allows intervention (e.g., surgery, chemotherapy, pharmaceutical treatment) that may extend life or lead to remission. Further problems in oncology include the monitoring of the efficacy of treatment, the titration of the dose of a therapeutic agent, the recurrence of a tumor either in the same organ as the primary tumor or at distal locations and the detection of metastasis. The current invention may be used for all these applications.

**[0228]** In some embodiments, the probe sets of the present disclosure may be configured to target known genetic variations associated with tumors. These may include mutations, SNPs, copy number variants (e.g., amplifications, deletions), copy neutral variants (e.g., inversions, translocations), and/or complex combinations of these variants. For example, the known genetic variations associated with tumors include those listed in [cancer.sanger.ac.uk/cancergenome/projects/cosmic](http://cancer.sanger.ac.uk/cancergenome/projects/cosmic); [nature.com/ng/journal/v45/n10/full/ng.2760.html#supplementary-information](http://nature.com/ng/journal/v45/n10/full/ng.2760.html#supplementary-information); and Tables 2 and 3 below: <sup>B</sup>GENE = p-value from corrected to FDR within peak; <sup>K</sup>Known frequently amplified oncogene or deleted TSG; <sup>P</sup>Putative cancer gene; <sup>E</sup>Epigenetic regulator; <sup>M</sup>Mitochondria-associated gene; <sup>\*\*</sup>Immediately adjacent to peak region; <sup>T</sup>Adjacent to telomere or centromere of acrocentric chromosome.

20

25

30

35

40

45

50

55

Table 2: Exemplary genetic variations associated with tumors (Amplification of the gene)

Peak Name	Rank	Genomic location	Peak region	GISTIC q-value	Gene count	Target(s)	Frequently mutated genes <sup>B</sup>
CCND1	1	11q13.3	chr11:69464719-69502928	2.05E-278	2	CCND1 <sup>K</sup>	CCND1 = 6.6e-08
EGFR	2	7p11.2	chr7:55075808-55093954	2.30E-240	1	EGFR <sup>K</sup>	EGFR = 2.2e-15
MYC	3	8q24.21	chr8:128739772-128762863	6.50E-180	1	MYC <sup>K</sup>	
TERC	4	3q26.2	chr3:169389459-169490555	5.40E-117	2	TERC <sup>P</sup>	
ERBB2	5	17q12	chr17:37848534-37877201	1.59E-107	1	ERBB2 <sup>K</sup>	ERBB2 = 1.3e-06
CCNE1	6	19q12	chr19:30306758-30316875	4.77E-90	1	CCNE1 <sup>K</sup>	
MCL1	7	1q21.3	chr1:150496857-150678056	1.25E-80	6	MCL1 <sup>K</sup>	
MDM2	8	12q15	chr12:69183279-69260755	2.59E-62	2	MDM2 <sup>K</sup>	
INTS4	9	11q14.1	chr11:77610143-77641464	1.01E-54	1	INTS4	
WHSC1L1	10	8p11.23	chr8:38191804-38260814	3.43E-46	2	WHSC1L1 <sup>E</sup> , LETM2 <sup>M</sup>	
CDK4	11	12q14.1	chr12:58135797-58156509	5.14E-41	5	CDK4 <sup>K</sup>	CDK4 = 0.0048
KAT6A	12	8p11.21	chr8:41751300-41897859	2.97E-39	2	KAT6A <sup>P,E</sup> , IKBKB <sup>**</sup>	
SOX2	13	3q26.33	chr3:181151312-181928394	1.21E-38	2	SOX2 <sup>K</sup>	
PDGFRA	14	4q12	chr4:54924794-55218386	1.08E-37	3	PDGFRA <sup>K</sup>	
BDH1	15	3q29	chr3:197212101-197335320	1.21E-31	1	BDH1 <sup>M</sup>	
1q44	16	1q44 <sup>T</sup>	chr1:242979907-249250621	4.48E-31	83	SMYD3 <sup>E</sup>	
MDM4	17	1q32.1	chr1:204367383-204548517	1.98E-29	3	MDM4 <sup>K</sup>	
TERT	18	5p15.33	chr5:1287704-1300024	9.34E-27	1	TERT <sup>K</sup>	
KDM5A	19	12p13.33 <sup>T</sup>	chr12:1-980639	1.59E-25	11	KDM5A <sup>E</sup>	
MYCL1	20	1p34.2	chr1:40317971-40417342	3.99E-25	2	MYCL1 <sup>K</sup>	
IGF1R	21	15q26.3	chr15:98667475-100292401	8.62E-25	9	IGF1R <sup>K</sup>	
PARP10	22	8q24.3	chr8:144925436-145219779	5.44E-20	15	PARP10 <sup>P,E</sup> , CYC1 <sup>M</sup>	
G6PD	23	Xq28	chrX:153760870-153767853	3.66E-19	1	G6PD	
PHF12	24	17q11.2	chr17:27032828-27327946	1.75E-16	21	PHF12 <sup>E</sup> , ERAL1 <sup>M</sup>	
20q13.33	25	20q13.33	chr20:62187847-62214354	2.96E-16	2		

(continued)

Peak Name	Rank	Genomic location	Peak region	GISTIC q-value	Gene count	Target(s)	Frequently mutated genes <sup>B</sup>
PAF1	26	19q13.2	chr19:39699366-39945515	1.66E-15	13	PAF1 <sup>P,E</sup>	IL28A=0.021, SUPT5H=0.084
BCL2L1	27	20q11.21	chr20:30179028-30320705	2.85E-15	4	BCL2L1 <sup>K</sup>	
TUBD1	28	17q23.1	chr17:57922443-57946458	7.19E-15	1	TUBD1	TUBD1 = 0.009
[ZNF703]	29	8p11.23	chr8:37492669-37527108	2.44E-14	0		
1q23.3	30	1q23.3	chr1:160949115-161115281	7.73E-13	9		
8q22.2	31	8q22.2	chr8:101324079-101652657	4.22E-11	3		SNX31 = 0.015
BRD4	32	19p13.12	chr19:15310246-15428182	5.04E-10	3	NOTCH3 <sup>P</sup> , BRD4 <sup>P,E</sup>	
KRAS	33	12p12.1	chr12:24880663-25722878	9.47E-10	7	KRAS <sup>K</sup>	KRAS = 1.5e-14
NKX2-1	34	14q13.2	chr14:35587755-37523513	1.33E-09	14	NKX2-1 <sup>K</sup>	NFKBIA=0.0098, RALGAP1=0.027
NFE2L2	35	2q31.2	chr2:178072322-178171101	5.48E-09	5	NFE2L2	NFE2L2 = 3.9e-14
ZNF217	36	20q13.2	chr20:52148496-52442225	5.83E-08	1	ZNF217 <sup>K</sup>	ZNF217 = 0.0082
13q34	37	13q34 <sup>T</sup>	chr13:108818892-115169878	6.28E-08	45	ING1 <sup>E</sup>	ING1 = 0.00026
KAT6B	38	10q22.2	chr10:76497097-77194071	1.41E-07	9	KAT6B <sup>E</sup> , VDACC2 <sup>M</sup>	
NSD1	39	5q35.3	chr5:176337344-177040112	1.75E-06	22	NSD1 <sup>E</sup> , PRELID1 <sup>M</sup>	NSD1 = 4.9e-10
FGFR3	40	4p16.3	chr4:1778797-1817427	2.14E-06	2	FGFR3 <sup>P</sup> , LETM1 <sup>M</sup>	FGFR3 = 0.00018
9p13.3	41	9p13.3	chr9:35652385-35739486	2.55E-06	8		
COX18	42	4q13.3	chr4:73530210-74658151	2.68E-06	7	COX18 <sup>M</sup>	
7q36.3	43	7q36.3 <sup>T</sup>	chr7:153768037-159138663	3.19E-06	30	PTPRN2 <sup>L</sup> , DPP6 <sup>L</sup>	
18q11.2	44	18q11.2	chr18:23857484-24119078	3.83E-06	2		
SOX17	45	8q11.23	chr8:55069781-55384342	2.02E-05	1	SOX17	SOX17 = 0.00092
11q22.2	46	11q22.2	chr11:102295593-102512085	0.00015337	3		
CBX8	47	17q25.3	chr17:7770110-77795534	0.00023029	1	CBX8 <sup>E</sup>	
AKT1	48	14q32.33	chr14:105182581-10533748	0.00028451	7	AKT1 <sup>K</sup>	AKT1 = 1.1e-14
CDK6	49	7q21.2	chr7:92196092-92530348	0.00069831	3	CDK6 <sup>K</sup>	
6p21.1	50	6p21.1	chr6:41519930-44297771	0.0010459	70		

(continued)

Peak Name	Rank	Genomic location	Peak region	GISTIC q-value	Gene count	Target(s)	Frequently mutated genes <sup>B</sup>
EHF	51	11p13	chr11:34574296-34857324	0.0011002	1	<i>EHF</i>	
6q21	52	6q21	chr6:107098934-107359899	0.0011806	4		
19q13.42	53	19q13.42 <sup>T</sup>	chr19:55524376-59128983	0.0013319	138	<i>TRIM28<sup>E</sup>, SUV420H2<sup>E</sup></i>	<i>ZNF471 = 5.4e-05</i>
17q21.33	54	17q21.33	chr17:47346425-47509605	0.0025775	2		
BPTF	55	17q24.2	chr17:65678858-66288612	0.0028375	11	<i>BPTF</i>	
E2F3	56	6p22.3	chr6:19610794-22191922	0.0033658	7	<i>E2F3<sup>K</sup></i>	
19p13.2	57	19p13.2	chr19:10260457-10467501	0.0038041	12	<i>MRPL4<sup>M</sup></i>	<i>DNMT1 = 0.099</i>
17q25.1	58	17q25.1	chr17:73568926-73594884	0.012337	2		
KDM2A	59	11q13.2	chr11:67025375-67059633	0.012445	3	<i>KDM2A<sup>E</sup></i>	
8q21.13	60	8q21.13	chr8:80432552-81861219	0.020548	6	<i>MRPS2<sup>S</sup><sup>M</sup></i>	
2p15	61	2p15	chr2:59143237-63355557	0.021056	25		<i>XPO1 = 1.1e-05</i>
14q11.2	62	14q11.2 <sup>T</sup>	chr14:1-21645085	0.027803	57		
NEDD9	63	6p24.2	chr6:11180426-11620845	0.082606	2	<i>NEDD9<sup>K</sup></i>	
5p13.1	64	5p13.1	chr5:35459650-50133375	0.094657	61		<i>SLC1A3=0.0021, IL7R=0.0021</i>
LINC00536	65	8q23.3	chr8:116891361-117360815	0.095294	1	<i>LINC00536</i>	
10p15.1	66	10p15.1	chr10:4190059-6130004	0.10391	21		
22q11.21	67	22q11.21	chr22:18613558-23816427	0.13213	105		
PHF3	68	6q12	chr6:63883156-64483307	0.17851	4	<i>PHF3<sup>E</sup>, EYS<sup>L</sup></i>	<i>PHF3 = 0.051</i>
PAX8	69	2q13	chr2:113990138-114122826	0.19717	2	<i>PAX8<sup>K</sup></i>	
9p24.2	70	9p24.2 <sup>T</sup>	chr9:1-7379570	0.20405	45	<i>SMARCA2<sup>E</sup>, KDM4C<sup>E</sup>, UHRF2<sup>E</sup>, KIAA2026<sup>E</sup></i>	

Table 3: Exemplary genetic variations associated with tumors (Deletion of the gene)

Peak Name	Rank	Genomic location	Peak region	GISTIC q-value	Gene count	Target(s)	Frequently mutated genes <sup>B</sup>
CDKN2A	1	9p21.3	chr9:21865498-22448737	0	4	CDKN2A <sup>K</sup>	CDKN2A = 4.4e-15
STK11	2	19p13.3	chr19:1103715-1272039	1.46E-238	7	STK11 <sup>K</sup>	STK11 = 2.5e-13
PDE4D	3	5q11.2	chr5:58260298-59787985	2.02E-143	3	PDE4D <sup>L</sup>	
PARK2	4	6q26	chr6:161693099-163153207	5.85E-137	1	PARK2 <sup>L-K</sup>	
LRP1B	5	2q22.1	chr2:139655617-143637838	4.25E-107	1	LRP1B <sup>L</sup>	
CSMD1	6	8p23.2	chr8:2079140-6262191	2.39E-96	1	CSMD1 <sup>L</sup>	
1p36.23	7	1p36.23	chr1:7829287-8925111	1.23E-93	8		
ARID1A	8	1p36.11	chr1:26900639-27155421	5.74E-87	2	ARID1A <sup>K</sup>	ARID1A = 1.5e-14
PTEN	9	10q23.31	chr10:89615138-90034038	1.12E-79	2	PTEN <sup>K</sup>	PTEN = 2.2e-15
WWOX	10	16q23.1	chr16:78129058-79627770	8.14E-76	1	WWOX <sup>L</sup>	WWOX = 0.092
RB1	11	13q14.2	chr13:48833767-49064807	3.88E-75	2	RB1 <sup>K</sup>	RB1 = 1.7e-13
FAM190A	12	4q22.1	chr4:90844993-93240505	9.26E-75	1	FAM190A <sup>L</sup>	
2q37.3	13	2q37.3 <sup>T</sup>	chr2:241544527-243199373	1.77E-70	29	ING5 <sup>E</sup>	
22q13.32	14	22q13.32 <sup>T</sup>	chr22:48026910-51304566	8.20E-65	45	BRD1 <sup>E</sup> , HDAC10 <sup>E</sup>	
11p15.5	15	11p15.5 <sup>T</sup>	chr11:1-709860	1.02E-62	34	SIRT3 <sup>E</sup> , PHRF1 <sup>E</sup>	HRAS = 7.8e-13
LINC00290	16	4q34.3	chr4:178911874-183060693	1.21E-55	1	LINC00290	
FHIT	17	3p14.2	chr3:59034763-61547330	3.01E-55	1	FHIT <sup>L</sup>	
RBFOX1	18	16p13.3	chr16:5144019-7771745	1.00E-45	1	RBFOX1 <sup>L</sup>	
PTPRD	19	9p24.1	chr9:8310705-12693402	3.24E-38	1	PTPRD <sup>L</sup>	
18q23	20	18q23 <sup>T</sup>	chr18:74979706-78077248	1.69E-37	12		
FAT1	21	4q35.2	chr4:187475875-188227950	6.81E-36	1	FAT1 <sup>K</sup>	FAT1 = 2.4e-15
MPHOSP H8	22	13q12.11 <sup>T</sup>	chr13:1-20535070	2.57E-31	10	MPHOSPH8 <sup>F</sup>	
15q15.1	23	15q15.1	chr15:41795901-42068054	2.71E-29	4		MGA = 0.0083, RPAP1=0.035

(continued)

Peak Name	Rank	Genomic location	Peak region	GISTIC q-value	Gene count	Target(s)	Frequently mutated genes <sup>B</sup>
11q25	24	11q25 <sup>T</sup>	chr11: 133400280-135006516	4.93E-26	14		
1p13.2	25	1p13.2	chr1:110048528-117687124	1.69E-25	100	TRIM33 <sup>E</sup>	NRAS=1.8e-13, CD58=0.079
NF1	26	17q11.2	chr17:29326736-29722618	6.59E-23	5	NF1 <sup>K</sup>	NF1 = 3.3e-13
MACROD2	27	20p12.1	chr20:14302876-16036135	9.00E-19	3	MACROD2 <sup>L</sup>	
7p22.3	28	7p22.3 <sup>T</sup>	chr7:1-1496620	1.04E-17	18		
6p25.3	29	6p25.3	chr6:1608837-2252425	3.01E-17	2		
21q11.2	30	21q11.2 <sup>T</sup>	chr21:1-15482604	2.34E-14	14		
9p13.1	31	9p13.1	chr9:38619152-71152237	9.75E-14	48		
ZNF132	32	19q13.43 <sup>T</sup>	chr19:58661582-59128983	3.77E-13	24	TRIM28 <sup>E</sup> , ZNF132	
5q15	33	5q15	chr5:73236070-114508587	8.15E-13	156	APCK, CHD1 <sup>E</sup>	APC=2.6e-13, RAS17=0.0029
MLL3	34	7q36.1	chr7:151817415-152136074	9.26E-13	1	MLL3 <sup>K</sup>	MLL3 = 1.1e-05
19q13.32	35	19q13.32	chr19:47332686-47763284	2.38E-12	10		
15q12	36	15q12 <sup>T</sup>	chr15:1-32929863	3.40E-11	155		OTUD7A = 0.027
12q24.33	37	12q24.33 <sup>T</sup>	chr12: 131692956-133851895	1.24E-10	27		POLE=3.9E-05, PGAM5=0.038
10q26.3	38	10q26.3 <sup>T</sup>	chr10: 135190263-135534747	2.09E-10	14		
6q21	39	6q21	chr6:86319089-117076132	4.56E-10	141	PRDM1 <sup>E</sup> , HDAC2 <sup>E</sup> , PRDM13 <sup>E</sup>	PRDM1 = 0.00054
PPP2R2A	40	8p21.2	chr8:25896447-26250295	1.78E-09	1	PPP2R2A	
IKZF2	41	2q34	chr2:211542637-214143899	3.24E-09	4	IKZF2 <sup>K</sup> , ERBB4 <sup>L</sup>	ERBB4 = 0.00058
CNTN4	42	3p26.3 <sup>T</sup>	chr3:1-3100786	6.44E-09	3	CNTN4 <sup>L</sup>	
3p12.2	43	3p12.2	chr3:75363575-86988125	1.22E-07	12	ROBO1 <sup>L</sup> , CADM2 <sup>L</sup>	

(continued)

Peak Name	Rank	Genomic location	Peak region	GISTIC q-value	Gene count	Target(s)	Frequently mutated genes <sup>B</sup>
RAD51B	44	14q24.1	chr14:68275375-69288431	1.38E-07	2	RAD51B <sup>L</sup>	ZFP36L1 = 0.0016
11q23.1	45	11q23.1	chr11: 105849158-117024891	5.31E-07	84	ATM <sup>K</sup>	ATM=1.4e-06, POU2AF1=0.082
IMMP2L	46	7q31.1	chr7:109599468-111366370	5.74E-07	2	IMMP2L <sup>L</sup>	
NEGR1	47	1p31.1	chr1:71699756-74522473	7.25E-07	2	NEGR1 <sup>L</sup>	
BRCA1	48	17q21.31	chr17:41178765-41336147	7.25E-07	2	BRCA1 <sup>K</sup>	BRCA1 = 3.5e-08
9q34.3	49	9q34.3	chr9:135441810-139646221	8.73E-06	94	NOTCH1 <sup>K</sup> , BRD3 <sup>E</sup> , GTF3C4 <sup>E</sup>	NOTCH1=1e-08, RXRA=2.1e-05, COL5A1=0.0022, TSC1=0.012
ANKS1B	50	12q23.1	chr12:99124001-100431272	8.73E-06	2	ANKS1B <sup>L</sup>	
DMD	51	Xp21.2	chrX:30865118-34644819	5.15E-05	4	DMD <sup>L</sup>	
ZMYND11	52	10p15.3 <sup>T</sup>	chr10:1-857150	7.12E-05	4	ZMYND11 <sup>E</sup>	
PRKG1	53	10q11.23	chr10:52644085-54061437	9.79E-05	3	PRKG1 <sup>L</sup>	
FOXK2	54	17q25.3	chr17:80443432-80574531	0.00019271	1	FOXK2	
AGBL4	55	1p33	chr1:48935280-50514967	0.000219	2	AGBL4 <sup>L</sup>	
CDKN1B	56	12p13.1	chr12:12710990-12966966	0.00035777	5	CDKN1B <sup>K</sup>	CDKN1B = 2.2e-06
14q32.33	57	14q32.33 <sup>T</sup>	chr14:94381429-107349540	0.00074358	227	SETD3 <sup>E</sup> , TDRD9 <sup>E</sup>	AKT1=2.1e-13, TRAF3=9.1e-05
14q11.2	58	14q11.2 <sup>T</sup>	chr14:1-30047530	0.0010181	162	PRMT5 <sup>E</sup> , CHD8 <sup>E</sup>	CHD8 = 0.034
2p25.3	59	2p25.3 <sup>T</sup>	chr2:1-20072169	0.0011137	86	MYCN <sup>K</sup>	MYCN=0.068
5q35.3	60	5q35.3 <sup>T</sup>	chr5:153840473-180915260	0.0028515	212	NSD1 <sup>E</sup> , ODZ2 <sup>L</sup>	NPM1=3.5e-13, NSD1=1.9e-09, ZNF454=0.0019, UBLCP1=0.03, GABRB2=0.07

(continued)

Peak Name	Rank	Genomic location	Peak region	GISTIC q-value	Gene count	Target(s)	Frequently mutated genes <sup>B</sup>
PTTG1IP	61	21q22.3	chr21:46230687-46306160	0.012227	1	<i>PTTG1IP</i>	
22q11.1	62	22q11.1 <sup>T</sup>	chr22:1-17960585	0.020332	15		
SMAD4	63	18q21.2	chr18:48472083-48920689	0.036866	3	<i>SMAD4<sup>K</sup></i>	<i>SMAD4</i> = 6.6e-15
17p13.3	64	17p13.3 <sup>T</sup>	chr17: 1-1180022	0.040814	16		
4p16.3	65	4p16.3 <sup>T</sup>	chr4:1-1243876	0.056345	27		
9p21.2	66	9p21.2	chr9:27572512-28982153	0.091742	3		
10q25.1	67	10q25.1	chr10:99340084-113910615	0.11879	137	<i>HPSE2<sup>L</sup></i> , <i>SMNDC1<sup>E</sup></i>	<i>SMC3</i> =0.00031, <i>GSTO2</i> =0.086
SMYD3	68	1q44	chr1:245282267-247110824	0.15417	8	<i>SMYD3<sup>E</sup></i>	
8p11.21	69	8p11.21	chr8:42883855-47753079	0.17382	4		
Xp22.33	70	Xp22.33 <sup>T</sup>	chrX:1-11137490	0.21462	52		<i>MXRA5</i> = 0.031

**[0229]** In the method of diagnosing cancer according to some embodiments, inversions that occur at known locations (Figure 67A) may easily be targeted by designing probes that at least partially overlap the breakpoint in one probe arm. A first probe that binds the "normal" sequence targets non-inverted genomic material (Figure 67B) and carries a first label type. A second probe that binds the "inverted" target carries a second label type (Figure 67C). A common right probe arm binds native sequence that is not susceptible to inversion, immediately adjacent the first two probes. This right probe arm further carries a common pull-down tag that localizes the probe products to the same region of an imaging substrate. In this way, the probe pairs may hybridize to the genomic targets, ligate, and be imaged to yield relative counts of the two underlying species.

**[0230]** Similarly, translocations that have known breakpoints may also be assayed. Figure 68A shows two genetic elements that are either in their native order or translocated. Probe arms that at least partially overlap these translocation breakpoints allow differentiation between normal and transposed orders of genetic material. As shown in Figures 68B and 68C, by choosing unique labels on the two left arms, the resulting ligated probe products may be distinguished and counted during imaging.

**[0231]** These methods for detecting copy neutral changes (e.g., inversions, translocation) may also be used to detect germline variants in cancer or in other disease or conditions.

**[0232]** Mutations or SNPs are also implicated in numerous cancers, and are targeted in a similar manner to those that are interrogated in determining fetal fraction in the prenatal diagnostics application. In some embodiments shown in Figures 69A and 69B, left probe arms are designed to take advantage of an energetic imbalance caused by one or more mismatched SNPs. This causes one probe arm (1101, carrying one label) to bind more favorably than a second probe arm (1107, carrying a second type of label). Both designs ligate to the same right probe arm (1102) that carries the universal pull-down tag.

**[0233]** A given patient's blood may be probed by one method, or a hybrid of more than one method. Further, in some cases, customizing specific probes for a patient may be valuable. This would involve characterizing tumor features (SNPs, translocations, inversions, etc.) in a sample from the primary tumor (e.g., a biopsy) and creating one or more custom probe sets that is optimized to detect those patient-specific genetic variations in the patient's blood, providing a low-cost, non-invasive method for monitoring. This could have significant value in the case of relapse, where detecting low-level recurrence of a tumor type (identical or related to the original tumor) as early as possible is ideal.

**[0234]** For common disease progression pathways, additional panels may be designed to anticipate and monitor for disease advancement. For example, if mutations tend to accumulate in a given order, probes may be designed to monitor current status and progression "checkpoints," and guide therapy options.

**[0235]** Early detection of cancer: For example, the ALK translocation has been associated with lung cancer. A probe designed to interrogate the ALK translocation may be used to detect tumors of this type via a blood sample. This would be highly advantageous, as the standard method for detecting lung tumors is via a chest x-ray an expensive procedure that may be deleterious to the patient's health and so is not standardly performed.

**[0236]** Detection of recurrence of the primary tumor type: For example, a HER2+ breast tumor is removed by surgery and the patient is in remission. A probe targeting the HER2 gene may be used to monitor for amplifications of the HER2 gene at one or more time points. If these are detected, the patient may have a second HER2+ tumor either at the primary site or elsewhere.

**[0237]** Detection of non-primary tumor types: For example, a HER2+ breast tumor is removed by surgery and the patient is in remission. A probe targeting the EGFR gene may be used to monitor for EGFR+ tumors. If these are detected, the patient may have a second EGFR+ tumor either at the primary site or elsewhere.

**[0238]** Detection of metastasis: For example, the patient has a HER2+ breast tumor. A probe designed to interrogate the ALK translocation may be used to detect tumors of this type via a blood sample. This tumor may not be in the breast and is more likely to be in the lung. If these are detected, the patient may have a metastatic tumor distal to the primary organ.

**[0239]** Determining tumor heterogeneity: Many tumors have multiple clonal populations characterized by different genetic variants. For example, a breast tumor may have one population of cells that are HER2+ and another population of cells that are EGFR+. Using probes designed to target both these variants would allow the identification of this underlying genetic heterogeneity.

**[0240]** Measurement of tumor load: In all the above examples, the quantity of tumor cfDNA may be measured and may be used to determine the size, growth rate, aggressiveness, stage, prognosis, diagnosis and other attributes of the tumor and the patient. Ideally, measurements are made at more than one time point to show changes in the quantity of tumor cfDNA.

**[0241]** Monitoring treatment: For example, a HER2+ breast tumor is treated with Herceptin. A probe targeting the HER2 gene may be used to monitor for quantity of tumor cfDNA, which may be a proxy for the size of the tumor. This may be used to determine if the tumor is changing in size and treatment may be modified to optimize the patient's outcome. This may include changing the dose, stopping treatment, changing to another therapy, combining multiple therapies.

**[0242]** Screening for tumor DNA: There is currently no universal screen for cancer. The present invention offers a way

## EP 3 036 545 B1

to detect tumors at some or all locations in the body. For example, a panel of probes is developed at a spacing of 100 kb across the genome. This panel may be used as a way to detect genetic variation across the genome. In one example, the panel detects copy number changes of a certain size across the genome. Such copy number changes are associated with tumor cells and so the test detects the presence of tumor cells. Different tumor types may produce different quantities of tumor cfDNA or may have variation in different parts of the genome. As such, the test may be able to identify which organ is affected. Further the quantity of tumor cfDNA measured may indicate the stage or size of the tumor or the location of the tumor. In this way, the test is a whole-genome screen for many or all tumor types.

**[0243]** For all the above tests, in order to mitigate false positives, a threshold may be used to determine the presence or certainty of a tumor. Further, the test may be repeat on multiple sample or at multiple time points to increase the certainty of the results. The results may also be combined with other information or symptoms to provide more information or more certain information on the tumor.

**[0244]** Exemplary probe sets and primers that may be used in the method described herein to measure copy number of nucleic acid regions of interest are listed in Table 4 below. Each of the exemplary probe sets in Table 4 comprises two probes. The first (tagging) probe has a structure including a forward priming site, tag, and homology 1. The second (labeling) probe has structure, including homology 2 and reverse primer site, which is used in labeling. The component sequences of the probes (tag, homology sequence etc.) are also shown.

20

25

30

35

40

45

50

55

Table 4: Exemplary probes and primers.

Chromosome	Locus ID	Tagging Probe (Forward Primer + Tag + 5pHom)	Labeling Probe (3'-Hop + Reverse Primer)	Forward primer	Tag	Hom 5p	Hom 3p	Reverse primer
18	18-1	GCCCTCATCTTC TTCCCTGGGTTT TCACCACCCCTCA CCAAGGAAGAA GTGAGGGCTTCT C (SEQ ID NO: 1)	CGTGCTAATAGTC TCAGGGCTTCCCTC CACCGAACGTGT CT (SEQ ID NO: 17)	GCCCTCAT CTTCTTCC CTGC (SEQ ID NO: 33)	GTTCTCA CCACCCCT CACCAA (SEQ ID NO: 34)	GGAAGAA GTGAGGG CTTCTC (SEQ ID NO: 35)	CGTGCTA ATAGTCT CAGGGC (SEQ ID NO: 51)	TTCCCTCCA CCGAACGT GTCT (SEQ ID NO: 67)
18	18-2	GCCCTCATCTTC TTCCCTGGGTTT TCACCACCCCTCA CCAAAATCAAG GTGACCAGCTCC (SEQ ID NO: 2)	CGACGCTTCATTG CTTCATTTCCCTC CACCGAACGTGT CT (SEQ ID NO: 18)	GCCCTCAT CTTCTTCC CTGC (SEQ ID NO: 33)	GTTCTCA CCACCCCT CACCAA (SEQ ID NO: 34)	AAATCAA GGTGACC AGCTCC (SEQ ID NO: 36)	CGACGC TTCATTG CTTCATT (SEQ ID NO: 52)	TTCCCTCCA CCGAACGT GTCT (SEQ ID NO: 67)
18	18-3	GCCCTCATCTTC TTCCCTGGGTTT TCACCACCCCTCA CCAATCATCTGC CAAGACAGAAG TTC (SEQ ID NO: 3)	CTTGGGCCAAAC AATTGTCCTTCCCT CCACCGAACGTG TCT (SEQ ID NO: 19)	GCCCTCAT CTTCTTCC CTGC (SEQ ID NO: 33)	GTTCTCA CCACCCCT CACCAA (SEQ ID NO: 34)	TCATCTG CCAAGAC AGAAGTT C (SEQ ID NO: 37)	CTTGCGC CAAACA ATTGTCC (SEQ ID NO: 53)	TTCCCTCCA CCGAACGT GTCT (SEQ ID NO: 67)
18	18-4	GCCCTCATCTTC TTCCCTGGGTTT TCACCACCCCTCA CCAAGCAGGAG AGTCAAAGGTCT G (SEQ ID NO: 4)	GCTGCAGAGTTTG CATTCAATTCCTC CACCGAACGTGT CT (SEQ ID NO: 20)	GCCCTCAT CTTCTTCC CTGC (SEQ ID NO: 33)	GTTCTCA CCACCCCT CACCAA (SEQ ID NO: 34)	GCAGGAG AGTCAAA GGTCTG (SEQ ID NO: 38)	GCTGCA GAGTTTG CATTCAT (SEQ ID NO: 54)	TTCCCTCCA CCGAACGT GTCT (SEQ ID NO: 67)
18	18-5	GCCCTCATCTTC TTCCCTGGGTTT TCACCACCCCTCA CCAAGTTGCCAT GGAGATTGTTGC (SEQ ID NO: 5)	CATACACACAGA CCGAGAGTCTTCC TCCACCGAACGT GTCT (SEQ ID NO: 21)	GCCCTCAT CTTCTTCC CTGC (SEQ ID NO: 33)	GTTCTCA CCACCCCT CACCAA (SEQ ID NO: 34)	GTTGCCA TGGAGAT TGTTC (SEQ ID NO: 39)	CATACA CACAGA CCGAGA GTC (SEQ ID NO: 55)	TTCCCTCCA CCGAACGT GTCT (SEQ ID NO: 67)

(continued)

Chromosome	Locus ID	Tagging Probe (Forward Primer + Tag + 5pHom)	Labeling Probe (3'-Hop + Reverse Primer)	Forward primer	Tag	Hom 5p	Hom 3p	Reverse primer
18	18-6	GCCCTCATCTTC TTCCCTGGGTTT TCACCAACCCCTCA CCAAACAGCTCAG TGATGTCAATTGC (SEQ ID NO: 6)	GGATGTCAGCCA GCATAAGTTTCCT CCACCGAACGTG TCT (SEQ ID NO: 22)	GCCCTCAT CTTCTTCC CTGC (SEQ ID NO: 33)	GTTCTCA CCACCCCT CACCAA (SEQ ID NO: 34)	CAGCTCA GTGATGT CATTGC (SEQ ID NO: 40)	GGATGT CAGCCA GCATAA GT (SEQ ID NO: 56)	TTCTCTCCA CCGAACGT GTCT (SEQ ID NO: 67)
18	18-7	GCCCTCATCTTC TTCCCTGGGTTT TCACCAACCCCTCA CCAAACCTTGACC TCTGCTAAATGTG G (SEQ ID NO: 7)	GAAAGTGCCAAA CAGTTCTTCTCCT CCACCGAACGTG TCT (SEQ ID NO: 23)	GCCCTCAT CTTCTTCC CTGC (SEQ ID NO: 33)	GTTCTCA CCACCCCT CACCAA (SEQ ID NO: 34)	CCTTGAC CTCTGCT AATGTGG (SEQ ID NO: 41)	GCAAGT GCCAAA CAGTTCT C (SEQ ID NO: 57)	TTCTCTCCA CCGAACGT GTCT (SEQ ID NO: 67)
18	18-8	GCCCTCATCTTC TTCCCTGGGTTT TCACCAACCCCTCA CCAAACACCTGTC CAACAGCTACAG (SEQ ID NO: 8)	GATTCAGCACA CTTGAGTCTTCC TCCACCGAACGT GTCT (SEQ ID NO: 24)	GCCCTCAT CTTCTTCC CTGC (SEQ ID NO: 33)	GTTCTCA CCACCCCT CACCAA (SEQ ID NO: 34)	CACCTGT CCAACAG CTACAG (SEQ ID NO: 42)	GATTCCA GCACAC TTGAGTC T (SEQ ID NO: 58)	TTCTCTCCA CCGAACGT GTCT (SEQ ID NO: 67)
X	X-1	GCCCTCATCTTC TTCCCTGGGTTT TCACCAACCCCTCA CCAAAGAATGTA TCTCAGGCCTG C (SEQ ID NO: 9)	CCGTTGCAGGTTT AAATGGCGCCCT ATTGCAAGCCCTC TT (SEQ ID NO: 25)	GCCCTCAT CTTCTTCC CTGC (SEQ ID NO: 33)	GTTCTCA CCACCCCT CACCAA (SEQ ID NO: 34)	AGAATGT ATCTTCA GGCCTGC (SEQ ID NO: 43)	CCGTTGC AGGTTTA AATGGC (SEQ ID NO: 59)	GCCCTATT GCAAGCCC TCTT (SEQ ID NO: 68)
X	X-2	GCCCTCATCTTC TTCCCTGGGTTT TCACCAACCCCTCA CCAAAAGTAATC ACTCTGGGTGGC (SEQ ID NO: 10)	CAAGAGTGCTTTA TGGGCTGCCCTA TTGCAAGCCCTCT T (SEQ ID NO: 26)	GCCCTCAT CTTCTTCC CTGC (SEQ ID NO: 33)	GTTCTCA CCACCCCT CACCAA (SEQ ID NO: 34)	AAGTAAT CACTCTG GGTGGC (SEQ ID NO: 44)	CAAGAG TGCTTTA TGGGCTT (SEQ ID NO: 60)	GCCCTATT GCAAGCCC TCTT (SEQ ID NO: 68)

(continued)

Chromosome	Locus ID	Tagging Probe (Forward Primer + Tag + 5pHom)	Labeling Probe (3'-Hop + Reverse Primer)	Forward primer	Tag	Hom 5p	Hom 3p	Reverse primer
X	X-3	GCCCTCATCTTC TTCCCTGGGTTT TCACCACCCCTCA CCAAAGCTCACA GACAACCTTGTG (SEQ ID NO: 11)	GCACTCAAGGAG ATCAGACTGGCC CTATTGCAAGCCC TCTT (SEQ ID NO: 27)	GCCCTCAT CTTCTTCC CTGC (SEQ ID NO: 33)	GTTCTCA CCACCCCT CACCAA (SEQ ID NO: 34)	AGCTCAC AGACAAC CTTGTG (SEQ ID NO: 45)	GCACTC AAGGAG ATCAGA CTG (SEQ ID NO: 61)	GCCCTATT GCAAGCCC TCTT (SEQ ID NO: 68)
X	X-4	GCCCTCATCTTC TTCCCTGGGTTT TCACCACCCCTCA CCAAAGCAATAGA CACCTACAGGCG (SEQ ID NO: 12)	GGTATCGAACT ACAACCACAGCC CTATTGCAAGCCC TCTT (SEQ ID NO: 28)	GCCCTCAT CTTCTTCC CTGC (SEQ ID NO: 33)	GTTCTCA CCACCCCT CACCAA (SEQ ID NO: 34)	GCAATAG ACACCTA CAGGGG (SEQ ID NO: 46)	GGCTATC GAACTA CAACCA CA (SEQ ID NO: 62)	GCCCTATT GCAAGCCC TCTT (SEQ ID NO: 68)
X	X-5	GCCCTCATCTTC TTCCCTGGGTTT TCACCACCCCTCA CCAAAGCACATTA TCAAAGGCCACG (SEQ ID NO: 13)	GTAGTGTCTGTG GTGTGATCGCCCT ATTGCAAGCCCTC TT (SEQ ID NO: 29)	GCCCTCAT CTTCTTCC CTGC (SEQ ID NO: 33)	GTTCTCA CCACCCCT CACCAA (SEQ ID NO: 34)	GCACATT ATCAAAG GCCACG (SEQ ID NO: 47)	GTAGCT GTCTGTG GTGTGAT C (SEQ ID NO: 63)	GCCCTATT GCAAGCCC TCTT (SEQ ID NO: 68)
X	X-6	GCCCTCATCTTC TTCCCTGGGTTT TCACCACCCCTCA CCAAACAACGACC TAAAGCATGTGC (SEQ ID NO: 14)	CAAGAAACTTCG AGCCTTAGCAGC CCTATTGCAAGCC CTCTT (SEQ ID NO: 30)	GCCCTCAT CTTCTTCC CTGC (SEQ ID NO: 33)	GTTCTCA CCACCCCT CACCAA (SEQ ID NO: 34)	CAACGAC CTAAAGC ATGTGC (SEQ ID NO: 48)	CAAGAA ACTTCGA GCCTTAG CA (SEQ ID NO: 64)	GCCCTATT GCAAGCCC TCTT (SEQ ID NO: 68)
X	X-7	GCCCTCATCTTC TTCCCTGGGTTT TCACCACCCCTCA CCAAAGACATACA TGGCTTGGCAG (SEQ ID NO: 15)	GTGAACCAGTCC GAGTGAAAGCCC TATTGCAAGCCCT CTT (SEQ ID NO: 31)	GCCCTCAT CTTCTTCC CTGC (SEQ ID NO: 33)	GTTCTCA CCACCCCT CACCAA (SEQ ID NO: 34)	GACATAC ATGGCTT TGGCAG (SEQ ID NO: 49)	GTGAAC CAGTCC GAGTGA AA (SEQ ID NO: 65)	GCCCTATT GCAAGCCC TCTT (SEQ ID NO: 68)

5

10

15

20

25

30

35

40

45

50

55

5  
10  
15  
20  
25  
30  
35  
40  
45  
50  
55

(continued)

Chromosome	Locus ID	Tagging Probe (Forward Primer + Tag + 5pHom)	Labeling Probe (3'-Hop + Reverse Primer)	Forward primer	Tag	Hom 5p	Hom 3p	Reverse primer
X	X-8	GCCCTCATCTTC TTCCCTGCGTTC TCACCAACCCTCA CCAAGAGATACT GCCACTTATGCA CG (SEQ ID NO: 16)	GCAAATGATGTTC AGCACACGCCC TATTGCAAGCCCT CTT (SEQ ID NO: 32)	GCCCTCAT CTTCTTCC CTGC (SEQ ID NO: 33)	GTTCTCA CCACCCT CACCAA (SEQ ID NO: 34)	GAGATAC TGCCACT TATGCAC G (SEQ ID NO: 50)	GCAAAT GATGTTC AGCACCC AC (SEQ ID NO: 66)	GCCCTATT GCAAGCCC TCTT (SEQ ID NO: 68)

## EP 3 036 545 B1

**[0245]** Exemplary probe sets and primers that may be used in the method described herein to detect a polymorphism at a SNP site are listed in Table 5 below. Each of the exemplary probe sets in Table 5 comprises three probes, two allele specific probes (that are used for labeling) and a tagging probe. In these examples, the two allele specific probes have homology sequences that are different at one or more nucleotides. The structure of the first allelic probe includes a Forward Primer Site Allele 1 and Homology Allele 1; and the structure of the second allelic probe includes a Forward Primer Site Allele 2 and Homology Allele 2. In practice, labeled primers may be used with different labels on the two primers (so the labels are allele specific). In these examples, there also is a universal 3' probe which includes a homology region (without any SNP), the tagging sequence and a reverse primer site. The component sequences of the probes (tag, homology sequence etc.) are also shown.

5

10

15

20

25

30

35

40

45

50

55

Table 5: Exemplary probes and primers.

Chromosome	Labeling Probe - Allele 1 (Forward Primer Allele 1 + Hom 5p Allele 1)	Labeling Probe - Allele 2 (Forward Primer Allele 2 + Hom 5p Allele 2)	Tagging Probe (Hom 3p + Tag + Reverse Primer)	Forward Primer - Allele 1	Forward Primer - Allele 2	Hom 5p - Allele 1	Hom 5p - Allele 2	Hom 3p	Tag	Reverse Primer
chr21	TTCCTCCACC GAACGTGTCT AGACCAGCAC AACTTACTcg (SEQ ID NO: 69)	GCCCTATTGCA AGCCCTCTTAG ACCAGCACAAAC TACTTa (SEQ ID NO: 112)	CACITGACAA AGTTCACAG CGCCGAAGTT CTCCGAAGGA TGCCCTCATC TTCCTCCCTGC (SEQ ID NO: 155)	TTCCCTC CACCGA ACGTGT CT (SEQ ID NO: 67)	GCCCTAT TGCAAG CCCTCTT (SEQ ID NO: 68)	AGACCA GCACAA CTTACTc g (SEQ ID NO: 198)	AGACC AGCAC AACTT ACTta (SEQ ID NO: 241)	CACTT GACA AAGTT CTCAC GC (SEQ ID NO: 284)	GCCGA AGTTC TCCGA AGGAT (SEQ ID NO: 327)	GCCCT CATCT TCTTC CCTGC (SEQ ID NO: 33)
chr3	TTCCTCCACC GAACGTGTCT CCAAATgCAC CTGCCfg (SEQ ID NO: 70)	GCCCTATTGCA AGCCCTCTTCCA AATcACCTGCC ca (SEQ ID NO: 113)	CATTAGGGAT TAACGGCTTG GGACAGACTG ACGGAGCTTC AGCCCTCATC TTCCTCCCTGC (SEQ ID NO: 156)	TTCCCTC CACCGA ACGTGT CT (SEQ ID NO: 67)	GCCCTAT TGCAAG CCCTCTT (SEQ ID NO: 68)	CCAAAT gCACCT GCCfg (SEQ ID NO: 199)	CCAAA TcACC TGCCca (SEQ ID NO: 242)	CATTA GGGAT TAACG GCTTG G (SEQ ID NO: 285)	GACA GACTG ACGG AGCTT CA (SEQ ID NO: 328)	GCCCT CATCT TCTTC CCTGC (SEQ ID NO: 33)
chr13	TTCCTCCACC GAACGTGTCT AGTTTGGACA AAGGCaATTcg (SEQ ID NO: 71)	GCCCTATTGCA AGCCCTCTTAGT TTGGACAAAGG CgATTta (SEQ ID NO: 114)	CACACGTTAA GAAGACTTTC TGCTGACTCT GCCGCACATG ATCGCCCTCA TCTTCTCCCT GC (SEQ ID NO: 157)	TTCCCTC CACCGA ACGTGT CT (SEQ ID NO: 67)	GCCCTAT TGCAAG CCCTCTT (SEQ ID NO: 68)	AGTTTG GACAAA GGCaAT Tcg (SEQ ID NO: 200)	AGTTT GGACA AAGGC gATTta (SEQ ID NO: 243)	CACAC GTTAA GAAG ACTTT CTGC (SEQ ID NO: 286)	TGACT CTGCC GCACA TGATC (SEQ ID NO: 329)	GCCCT CATCT TCTTC CCTGC (SEQ ID NO: 33)
chr3	TTCCTCCACC GAACGTGTCT TGAGCTTAGC CAATATCAAG AAGg (SEQ ID NO: 72)	GCCCTATTGCA AGCCCTCTTGA GCTTAGCCAAT ATCAAcAAg (SEQ ID NO: 115)	CTAAGTGCC TCCATGAGAA AGGATCCGAT AGCCCTCTGC AGGCCCTCAT CTTCTCCCTG	TTCCCTC CACCGA ACGTGT CT (SEQ ID NO: 67)	GCCCTAT TGCAAG CCCTCTT (SEQ ID NO: 68)	TGAGCT TAGCCA ATATCA AgAAg (SEQ ID NO: 201)	TGAGC TTAGC CAATA TCAAca AGa (SEQ ID NO: 244)	CTAAG TGCCC TCCAT GAGA AAG (SEQ ID NO: 286)	GATCC GATAG CCCTC TGCAG (SEQ ID NO: 329)	GCCCT CATCT TCTTC CCTGC (SEQ ID NO: 33)

5  
10  
15  
20  
25  
30  
35  
40  
45  
50  
55

chr9	TTCCTCCACC GAACGTGTCT ACGTGAACTT TCCTTGGTAcA c (SEQ ID NO: 73)	GCCCTATTGCA AGCCCTCTTAC GTGAACTTTCCT TGGTaaAt (SEQ ID NO: 116)	C (SEQ ID NO: 158) GCACAGATTT CCCACACTCT CAACAGGCCT GCTAAACACC GCCCTCATCT TCTTCCCTGC (SEQ ID NO: 159)	TTCCCTC CACCGA ACGTGT CT (SEQ ID NO: 67)	GCCCTAT TGCAAG CCCTCTT (SEQ ID NO: 68)	ACGTGA ACTTTC CTTGGT AcAc (SEQ ID NO: 202)	NO: 244) ACGTG AACTT TCCTTG GTaaAt (SEQ ID NO: 245)	ID NO: 287) GCACA GATTT CCCAC ACTCT (SEQ ID NO: 288)	330) CAACA GGCCT GCTAA ACACC (SEQ ID NO: 331)	33) GCCCT CATCT TCTTC CCTGC (SEQ ID NO: 33)
chr3	TTCCTCCACC GAACGTGTCT TGAAGATGTT CTAATACCTT GCeg (SEQ ID NO: 74)	GCCCTATTGCA AGCCCTCTTGA AGATGTCTAA TACCTTGctA (SEQ ID NO: 117)	CTTACAGGAG GTCTGGCATC AGGTCAACAA CCGAGGACT CGCCCTCATC TCTTCCCTGC (SEQ ID NO: 160)	TTCCCTC CACCGA ACGTGT CT (SEQ ID NO: 67)	GCCCTAT TGCAAG CCCTCTT (SEQ ID NO: 68)	TGAAGA TGTTCT AATACC TTGCcg (SEQ ID NO: 203)	TGAAG ATGTT CTAAT ACCTT GctA (SEQ ID NO: 246)	CTTAC AGGA GGTCT GGCAT CA (SEQ ID NO: 289)	GGTCA ACAAC CGAG GGACT C (SEQ ID NO: 332)	GCCCT CATCT TCTTC CCTGC (SEQ ID NO: 33)
chr17	TTCCTCCACC GAACGTGTCT CAGTGTGGAG ACtGAACg (SEQ ID NO: 75)	GCCCTATTGCA AGCCCTCTTCA GTGTGGAGACc GAAcA (SEQ ID NO: 118)	CCACAATGAG AAGGCAGAGT TGTCATTAAT GCTGGCGCGG CCCTCATCTTC TTCCTGC (SEQ ID NO: 161)	TTCCCTC CACCGA ACGTGT CT (SEQ ID NO: 67)	GCCCTAT TGCAAG CCCTCTT (SEQ ID NO: 68)	CAGTGT GGAGAC tGAACg (SEQ ID NO: 204)	CAGTG TGGAG ACcGA ACa (SEQ ID NO: 247)	CCACA ATGAG AAGG CAGA G (SEQ ID NO: 290)	TTGTC ATTAA TGCTG GCGGC (SEQ ID NO: 333)	GCCCT CATCT TCTTC CCTGC (SEQ ID NO: 33)
chr16	TTCCTCCACC GAACGTGTCT AGGCAGGGTA ATGTcATGAA aTg (SEQ ID NO: 76)	GCCCTATTGCA AGCCCTCTTAG GCAGGGTAATG TCATGAAgTt (SEQ ID NO: 119)	GCTGTGGCAT AGTACACTC CGGTGACGGT TTGCAACTTT GCCCTCATCT TCTTCCCTGC (SEQ ID NO: 162)	TTCCCTC CACCGA ACGTGT CT (SEQ ID NO: 67)	GCCCTAT TGCAAG CCCTCTT (SEQ ID NO: 68)	AGGCAG GGTAAT GTCATG AAaTg (SEQ ID NO: 205)	AGGCA GGTA ATGTC ATGAA gTt (SEQ ID NO: 248)	GCTGT GGCAT AGTA CACTC (SEQ ID NO: 291)	CGGTG ACGGT TTGCA ACTTT (SEQ ID NO: 334)	GCCCT CATCT TCTTC CCTGC (SEQ ID NO: 33)
chr21	TTCCTCCACC GAACGTGTCT	GCCCTATTGCA AGCCCTCTTGAT	CAGGGTAATT TGtGGTCTG	TTCCCTC CACCGA	GCCCTAT TGCAAG	GATTGT CTGGAG	GATTG TCTGG	CAGG GTAAT	GTCCG GCAGT	GCCCT CATCT

5  
10  
15  
20  
25  
30  
35  
40  
45  
50  
55

	GATTGTCTGG AGcGCTg (SEQ ID NO: 77)	TGCTGGAGgGC Tc (SEQ ID NO: 120)	GTCCGGCAGT TAAGGGTCTC GCCCTCATCT TCTTCCCTGC (SEQ ID NO: 163)	ACGTGT CT (SEQ ID NO: 67)	CCCTCTT (SEQ ID NO: 68)	cGCTg (SEQ ID NO: 206)	AGgC Tc (SEQ ID NO: 249)	TTGTG GGTCT G (SEQ ID NO: 292)	TAAGG GTCTC (SEQ ID NO: 335)	TCTTC CCTGC (SEQ ID NO: 33)
chr2	TTCCTCCACC GAACGTGTCT AGGGAGCAAT AGGcG (SEQ ID NO: 78)	GCCCTATTGCA AGCCCTCTTAG GGAGCAATAGG C <sup>ta</sup> (SEQ ID NO: 121)	GGGCTATCCA GAAAGATAAG AATACTACA AACGACTGG CAGCCCTCAT CTTCTTCCCTG C (SEQ ID NO: 164)	TTCCTC CACCGA ACGTGT CT (SEQ ID NO: 67)	GCCCTAT TGCAAG CCCTCTT (SEQ ID NO: 68)	AGGGAG CAATAG Gc <sup>g</sup> (SEQ ID NO: 207)	AGGA GCAAT AGGc <sup>ta</sup> (SEQ ID NO: 250)	GGGT ATCCA GAAA GATAA GAA (SEQ ID NO: 293)	TACTC ACAA ACGAC TGCGC A (SEQ ID NO: 336)	GCCCT CATCT TCTTC CCTGC (SEQ ID NO: 33)
chr2	TTCCTCCACC GAACGTGTCT CTGCAGGGTA CAAcAcG (SEQ ID NO: 79)	GCCCTATTGCA AGCCCTCTCTG CAGGGTACAAG ACa (SEQ ID NO: 122)	CATAACTGGT GGAGTATTTC ACTCGTATAT GGCCGACTGG AGGGCCCTCA TCTTCTTCCCT GC (SEQ ID NO: 165)	TTCCTC CACCGA ACGTGT CT (SEQ ID NO: 67)	GCCCTAT TGCAAG CCCTCTT (SEQ ID NO: 68)	CTGCAG GGTACA AcAc <sup>g</sup> (SEQ ID NO: 208)	CTGCA GGTA CAAgA Ca (SEQ ID NO: 251)	CATAA CTGGT GGAGT ATTTC ACT (SEQ ID NO: 294)	CGTAT ATGGC CGACT GGAG G (SEQ ID NO: 337)	GCCCT CATCT TCTTC CCTGC (SEQ ID NO: 33)
chr19	TTCCTCCACC GAACGTGTCT CGTATCTGGG AAGAcGc (SEQ ID NO: 80)	GCCCTATTGCA AGCCCTCTTCGT ATCTGGGAAGAT GGg (SEQ ID NO: 123)	CTTCAAGGAA GAAATTCAAC AGGTAGGGT TTGCGGCGAT AAGGGCCCTC ATCTTCTTCCC TGC (SEQ ID NO: 166)	TTCCTC CACCGA ACGTGT CT (SEQ ID NO: 67)	GCCCTAT TGCAAG CCCTCTT (SEQ ID NO: 68)	CGTATC TGGGAA GAcGc (SEQ ID NO: 209)	CGTAT CTGGG AAGAtG Gg (SEQ ID NO: 252)	CTTCA AGGA AGAA ATTCA ACAG GG (SEQ ID NO: 295)	TAGGG TTTGC GGG ATAAG G (SEQ ID NO: 338)	GCCCT CATCT TCTTC CCTGC (SEQ ID NO: 33)
chr9	TTCCTCCACC GAACGTGTCT CCTGTAATCC CTTGCAATgc (SEQ ID NO: 81)	GCCCTATTGCA AGCCCTCTTCTT GTAATCCCTTGC AAT <sup>aa</sup> (SEQ ID NO: 124)	CATGGATTCA ACACAGCAAA CACCAAGTCA ACCACCCGAG ACGCCCTCAT	TTCCTC CACCGA ACGTGT CT (SEQ ID NO: 67)	GCCCTAT TGCAAG CCCTCTT (SEQ ID NO: 68)	CCTGTA ATCCCT TGCAAT gc (SEQ ID NO: 209)	CCTGT AATCC CTTGC AAT <sup>aa</sup> (SEQ ID NO: 252)	CATGG ATTCA ACACA GCAA ACA	CCAAG TCAAC CACCC GAGA C (SEQ ID NO: 338)	GCCCT CATCT TCTTC CCTGC (SEQ ID NO: 33)

5  
10  
15  
20  
25  
30  
35  
40  
45  
50  
55

				CTTCTCCCTG C (SEQ ID NO: 167)	67)				210)	NO: 253)	(SEQ ID NO: 296)	ID NO: 339)	ID NO: 33)
chr16	TTCCTCCACC GAACGTGTCT GGTCTCAGCA CGGTCTg (SEQ ID NO: 82)	GCCCTATTGCA AGCCCTCTTGGT CTCAGCACGGTc CTt (SEQ ID NO: 125)	CTCTGACCTC CTTCACTCTTA CACTTCCCTG GCCCTCCCTTCT GCCCTCATCT TCTTCCCTGC (SEQ ID NO: 168)	TTCCTC CACCGA ACGTGT CT (SEQ ID NO: 67)	GCCCTAT TGCAAG CCCTCT (SEQ ID NO: 68)	GGTCTC AGCACG GTtCTg (SEQ ID NO: 211)	GGTCT CAGCA CGGTcC Tt (SEQ ID NO: 254)	CTCTG ACCTC CTTCA CTCTT AC (SEQ ID NO: 340)	ACTTC CCTGG CCTTC CTTCT (SEQ ID NO: 33)	GCCCT CATCT TCCTC CCTGC (SEQ ID NO: 33)			
chr9	TTCCTCCACC GAACGTGTCT GCACCTCCCT AcCACAc (SEQ ID NO: 83)	GCCCTATTGCA AGCCCTCTTGC ACCTCCCTAtCA CAt (SEQ ID NO: 126)	GCTTTCATTG TGCTAAACCT CGCTTGGTC CTCTCCTGAA CGCCCTCATC (SEQ ID NO: 169)	TTCCTC CACCGA ACGTGT CT (SEQ ID NO: 67)	GCCCTAT TGCAAG CCCTCT (SEQ ID NO: 68)	GCACCT CCCTAc CACAc (SEQ ID NO: 212)	GCACC TCCCT AtCACa t (SEQ ID NO: 255)	GCTTT CAATT GTGCT AAACC TC (SEQ ID NO: 341)	GCTTG GGTCC TCTCC TGAAC (SEQ ID NO: 33)	GCCCT CATCT TCCTC CCTGC (SEQ ID NO: 33)			
chr3	TTCCTCCACC GAACGTGTCT GCCTTAGCT AGAGAGAAgt c (SEQ ID NO: 84)	GCCCTATTGCA AGCCCTCTTGCC TCTAGCTAGAG AGAAGcg (SEQ ID NO: 127)	CATCCAGAT GCCCTATAA CGTCCGAACC ACAATGCTGC CCTCATCTTCT TCCCTGC (SEQ ID NO: 170)	TTCCTC CACCGA ACGTGT CT (SEQ ID NO: 67)	GCCCTAT TGCAAG CCCTCT (SEQ ID NO: 68)	GCCTCT AGCTAG AGAGAA Gtc (SEQ ID NO: 213)	GCCTC TAGCT AGAGA GAAGeg (SEQ ID NO: 256)	CATCC CAGAT GCCCT CAT (SEQ ID NO: 299)	AAGGT CCGAA CCACA ATGCT (SEQ ID NO: 342)	GCCCT CATCT TCCTC CCTGC (SEQ ID NO: 33)			
chr20	TTCCTCCACC GAACGTGTCT CTGGCAGTCT AGCCgTTAc (SEQ ID NO: 85)	GCCCTATTGCA AGCCCTCTTCTG GCAGTCTAGCCa TTAt (SEQ ID NO: 128)	GTAGAAATCC CAAGGCAATC AGCTCCCTGC ATCCAACAGT CGGCCCTCAT CTTCTCCCTG C (SEQ ID NO: 171)	TTCCTC CACCGA ACGTGT CT (SEQ ID NO: 67)	GCCCTAT TGCAAG CCCTCT (SEQ ID NO: 68)	CTGGCA GTCTAG CCgTTAc (SEQ ID NO: 214)	CTGGC AGTCT AGCCaT TAt (SEQ ID NO: 257)	GTAGA AATCC CAAG GCAAT CAG (SEQ ID NO: 300)	CTCCT CGCAT CCAAC AGTCG (SEQ ID NO: 343)	GCCCT CATCT TCCTC CCTGC (SEQ ID NO: 33)			
chrX	TTCCTCCACC GAACGTGTCT	GCCCTATTGCA AGCCCTCTTGT	GAACAATAA CTCCACAGAA	TTCCTC CACCGA	GCCCTAT TGCAAG	TGTCTT AGAATT	TGTCTT AGAAT	GAAC AACTA	CCACC GTAGC	GCCCT CATCT			

5  
10  
15  
20  
25  
30  
35  
40  
45  
50  
55

	TGCTTAGAA TTTGGCAACTg Gc (SEQ ID NO: 86)	CTTAGAATTG GCAACTaGt (SEQ ID NO: 129)	CCCCACCGT AGCACTCCTT CTTGCCCTCA TCCTTCCCT GC (SEQ ID NO: 172)	ACGTGT CT (SEQ ID NO: 67)	CCCTCTT (SEQ ID NO: 68)	TGGCAA CTgC (SEQ ID NO: 215)	TTGGC AACTaG t (SEQ ID NO: 258)	ACTCC ACAG AACCC (SEQ ID NO: 301)	ACTCC TTCTT (SEQ ID NO: 344)	TC TTC CCTGC (SEQ ID NO: 33)
chr7	TTCCTCCACC GAACGTGTCT GCAGGAAAGC CTAcTGAAc (SEQ ID NO: 87)	GCCCTATTGCA AGCCCTCTTGC AGGAAAGCCTAt TGAAt (SEQ ID NO: 130)	GTGCAGAGGA CAGGAAGAAC GGAGCGTCGG TAGTGTAAAG CCCTCATCTTC TTCCTGC (SEQ ID NO: 173)	TTCCTC CACCGA ACGTGT CT (SEQ ID NO: 67)	GCCCTAT TGCAAG CCCTCTT (SEQ ID NO: 68)	GCAGG AAAGC CTAtG AA (SEQ ID NO: 259)	GTGCA GAGG ACAG GAAG AA (SEQ ID NO: 302)	CGGA GCGTC GGTAG TGTA A (SEQ ID NO: 345)	GCCCT CATCT TC TTC CCTGC (SEQ ID NO: 33)	
chr3	TTCCTCCACC GAACGTGTCT GGAGCCAGA GAAAtgTCc (SEQ ID NO: 88)	GCCCTATTGCA AGCCCTCTTGG GAGCCAGAGAA ATtTc (SEQ ID NO: 131)	GGTGCTCAA GACATACACC TTAACAACTC GACGAACCTA CCGGCCCTCA TCCTTCCCT GC (SEQ ID NO: 174)	TTCCTC CACCGA ACGTGT CT (SEQ ID NO: 67)	GCCCTAT TGCAAG CCCTCTT (SEQ ID NO: 68)	GGGAG CCAGA GAAAt Tc (SEQ ID NO: 260)	GGTGC TTCAA GACAT ACACC TTA (SEQ ID NO: 303)	ACAAC TCGAC GAACC TACCG (SEQ ID NO: 346)	GCCCT CATCT TC TTC CCTGC (SEQ ID NO: 33)	
chr2	TTCCTCCACC GAACGTGTCT TGCTCCAGT TCCACTTCAt TAg (SEQ ID NO: 89)	GCCCTATTGCA AGCCCTCTTGT CTCCAGTCCAC TTCATgTaa (SEQ ID NO: 132)	GGAACTCTG TGACCTTGG TGGCCATCC TTATGTGCTG GCCCTCATCT TCCTCCCTGC (SEQ ID NO: 175)	TTCCTC CACCGA ACGTGT CT (SEQ ID NO: 67)	GCCCTAT TGCAAG CCCTCTT (SEQ ID NO: 68)	TGTCTC CAGTT CCTT TCATgT Aa (SEQ ID NO: 261)	GGAA CCTCT GTGAC CTTGG A (SEQ ID NO: 304)	TGGCC CATCC TTATG TGCTG (SEQ ID NO: 347)	GCCCT CATCT TC TTC CCTGC (SEQ ID NO: 33)	
chr15	TTCCTCCACC GAACGTGTCT CCCGTAAAT GCCTAcTcg (SEQ ID NO: 90)	GCCCTATTGCA AGCCCTCTTCCC GTTAATTGCCTA tTta (SEQ ID NO: 133)	CCCAGTGGTA CCTTCTGAAG GTCGTTATG CTCAAGCCCG CCCTCATCTTC TTCCTGC	TTCCTC CACCGA ACGTGT CT (SEQ ID NO: 67)	GCCCTAT TGCAAG CCCTCTT (SEQ ID NO: 68)	CCCCT TAAT GCCTAt Tta (SEQ ID NO: 262)	CCCAG TGGA CCTTC TGAA (SEQ ID NO: 304)	GGTGG TTATT GCTCA AGCCC (SEQ ID NO: 347)	GCCCT CATCT TC TTC CCTGC (SEQ ID NO: 33)	

5  
10  
15  
20  
25  
30  
35  
40  
45  
50  
55

chr15	TTCCTCCACC GAACGTGTCT CTCGGTCCCA CTGGaAaG (SEQ ID NO: 91)	GCCCTATTGCA AGCCCTCTTCTC GGTCCCACCTGGg AAa (SEQ ID NO: 134)	(SEQ ID NO: 176) CTTCTGTTGCT TATTGGGTA ACTTGATTCT GGCCCTCCCA TCGCCCTCAT CTTCTTCCCTG C (SEQ ID NO: 177)	TTCCCTC CACCGA ACGTGT CT (SEQ ID NO: 67)	GCCCTAT TGCAAG CCCTCTT (SEQ ID NO: 68)	CTCGGT CCCAC GGaAaG (SEQ ID NO: 220)	CTCGG TCCCA CTGGg AAa (SEQ ID NO: 263)	305) CTTCT GTTGC TTATT TGGGT AAC (SEQ ID NO: 306)	348) TTGAT TCTGG CCCTC CCATC (SEQ ID NO: 349)	33) GCCCT CATCT TCTTC CCTGC (SEQ ID NO: 33)
chr2	TTCCTCCACC GAACGTGTCT ACACCCATGA TTCAGTTACtg (SEQ ID NO: 92)	GCCCTATTGCA AGCCCTCTTAC AGCCATGATTTC AGTTACca (SEQ ID NO: 135)	CCACTGGAT GCCTCCCTCA CGCCGGCTAT TTAGGTGCC TCATCTTCTTC CCTGC (SEQ ID NO: 178)	TTCCCTC CACCGA ACGTGT CT (SEQ ID NO: 67)	GCCCTAT TGCAAG CCCTCTT (SEQ ID NO: 68)	ACACCC ATGATT CAGTTA Ctg (SEQ ID NO: 221)	ACACC CATGA TTCAG TTACca (SEQ ID NO: 264)	CCCAC TGGAT GCCTC C (SEQ ID NO: 307)	CTCAC GCCGG CTATT TAGGT (SEQ ID NO: 350)	GCCCT CATCT TCTTC CCTGC (SEQ ID NO: 33)
chr9	TTCCTCCACC GAACGTGTCT GCTAGTATGA ACATCACAgGc (SEQ ID NO: 93)	GCCCTATTGCA AGCCCTCTTGTCT AGTATGAACAT CACAAgt (SEQ ID NO: 136)	CGGAGAGACG CATCTGAAAG TCTGGGTAGG TGGAGGACGC CCTCATCTTCT TCCCTGC (SEQ ID NO: 179)	TTCCCTC CACCGA ACGTGT CT (SEQ ID NO: 67)	GCCCTAT TGCAAG CCCTCTT (SEQ ID NO: 68)	GCTAGT ATGAAC ATCAC gGc (SEQ ID NO: 222)	GCTAG TATGA ACATC ACAaGt (SEQ ID NO: 265)	CGGA GAGA CGCAT CTGAA (SEQ ID NO: 308)	AGTCT GGTA GGTGG AGGA C (SEQ ID NO: 351)	GCCCT CATCT TCTTC CCTGC (SEQ ID NO: 33)
chr7	TTCCTCCACC GAACGTGTCT ACAAATGAGT AAGAAGCGGAG Tcg (SEQ ID NO: 94)	GCCCTATTGCA AGCCCTCTTAC AAATGAGTAAG AAGCGAGTta (SEQ ID NO: 137)	CAGGATTTC AGCTTACAGG GCGACTGAGC CACATCCAAC TGCCCTCATC TTCTTCCCTGC (SEQ ID NO: 180)	TTCCCTC CACCGA ACGTGT CT (SEQ ID NO: 67)	GCCCTAT TGCAAG CCCTCTT (SEQ ID NO: 68)	ACAAAT GAGTAA GAAGCG AGTcg (SEQ ID NO: 223)	ACAAA TGAGT AAGAA GCGAG Tta (SEQ ID NO: 266)	CAGG ATTTC CAGCT TACAG GG (SEQ ID NO: 309)	CGACT GAGCC ACATC CAACT (SEQ ID NO: 352)	GCCCT CATCT TCTTC CCTGC (SEQ ID NO: 33)
chr20	TTCCTCCACC GAACGTGTCT GATAAGGGTT GCTCTgCg	GCCCTATTGCA AGCCCTCTTGTAT AAGGGTTGCTC TaCa (SEQ ID NO:	CTTGCAAGAT GTGCCCTTIA GAGCCTCAGC CGGAATTGAA	TTCCCTC CACCGA ACGTGT CT (SEQ	GCCCTAT TGCAAG CCCTCTT (SEQ ID	GATAAG GGTTC TCTgCg (SEQ ID	GATAA GGGTT GCTCTa Ca (SEQ	CTTGC AAGAT GTGCC TCTTA	GAGCC TCAGC CGGA ATTGA	GCCCT CATCT TCTTC CCTGC

5  
10  
15  
20  
25  
30  
35  
40  
45  
50  
55

	(SEQ ID NO: 95)	138)		GCCCTCATCT TCCTCCCTGC (SEQ ID NO: 181)	ID NO: 67)	NO: 68)	NO: 224)	ID NO: 267)	(SEQ ID NO: 310)	A (SEQ ID NO: 353)	(SEQ ID NO: 33)
chr20	TTCCTCCACC GAACGTGTCT CCATGCACCA GCTACcc (SEQ ID NO: 96)	GCCCTATTGCA AGCCCTCTTCCA TGCACCAAGCTA Cta (SEQ ID NO: 139)	TTCCTC CACCGA ACGTGT CT (SEQ ID NO: 67)	GCCCTAT TGCAAG CCCTCTT (SEQ ID NO: 68)	CCATGC ACCAAGC TACcc (SEQ ID NO: 225)	CCATG CACCA GCTACT a (SEQ ID NO: 268)	GGGTG GTTTC TCTAA ACACA AA (SEQ ID NO: 311)	GGGTG GTTTC TCTAA ACACA AA (SEQ ID NO: 354)	TTGCC ATTCT GCACC AATGC (SEQ ID NO: 33)	GCCCT CATCT TCTTC CCTGC (SEQ ID NO: 33)	
chr1	TTCCTCCACC GAACGTGTCT AACTGTACCC TACTCCCAGc (SEQ ID NO: 97)	GCCCTATTGCA AGCCCTCTTAA CTGTACCCCTACT CCCAat (SEQ ID NO: 140)	TTCCTC CACCGA ACGTGT CT (SEQ ID NO: 67)	GCCCTAT TGCAAG CCCTCTT (SEQ ID NO: 68)	AACITGT ACCTA CTCCCA gc (SEQ ID NO: 226)	AACITG TACCC TACTC CCAat (SEQ ID NO: 269)	GCAG GGTAT TGAGA GAAG GATC (SEQ ID NO: 312)	GCAG GGTAT TGAGA GAAG GATC (SEQ ID NO: 355)	TATTG GTGTT CGCGG CTGAT (SEQ ID NO: 33)	GCCCT CATCT TCTTC CCTGC (SEQ ID NO: 33)	
chr2	TTCCTCCACC GAACGTGTCT AGGACCAAGG GACCAGTtag (SEQ ID NO: 98)	GCCCTATTGCA AGCCCTCTTAG GACCAAGGGAC CAGTtAc (SEQ ID NO: 141)	TTCCTC CACCGA ACGTGT CT (SEQ ID NO: 67)	GCCCTAT TGCAAG CCCTCTT (SEQ ID NO: 68)	AGGACC AAGGGA CCAGTt Ag (SEQ ID NO: 227)	AGGAC CAAGG GACCA GTTcAc (SEQ ID NO: 270)	GTGCA CATT CTTGA TGAAG GG (SEQ ID NO: 313)	ATGGG CGTAA CAGG AGGA CT (SEQ ID NO: 356)	GCCCT CATCT TCTTC CCTGC (SEQ ID NO: 33)	GCCCT CATCT TCTTC CCTGC (SEQ ID NO: 33)	
chr7	TTCCTCCACC GAACGTGTCT AGAGTTCCTC CAAGAAAATTG cg (SEQ ID NO: 99)	GCCCTATTGCA AGCCCTCTTAG AGTTCCTCCAA GAAATTGta (SEQ ID NO: 142)	TTCCTC CACCGA ACGTGT CT (SEQ ID NO: 67)	GCCCTAT TGCAAG CCCTCTT (SEQ ID NO: 68)	AGAGTT CCTCCA AGAAAT TGcg (SEQ ID NO: 228)	AGAGT TCCTCC AAGAA ATTGta (SEQ ID NO: 271)	GAGC AATGC CTGTT TCATG AGA (SEQ ID NO: 314)	GGAAT GGCCT ACCTG CATCA (SEQ ID NO: 357)	GCCCT CATCT TCTTC CCTGC (SEQ ID NO: 33)	GCCCT CATCT TCTTC CCTGC (SEQ ID NO: 33)	

5  
10  
15  
20  
25  
30  
35  
40  
45  
50  
55

chr5	TTCCTCCACC GAACGTGTCT ACATTATACA GCATGCTGGc TAtc (SEQ ID NO: 100)	GCCCTATTGCA AGCCCTCTTAC ATTATACAGCA TGCTGGtAga (SEQ ID NO: 143)	GTAAACATTA TACAGCATGG TGGCCCGGT GTTGTATCG CATCGCCCTC ATCTTCTCCC TGC (SEQ ID NO: 186)	TTCCCTC CACCGA ACGTGT CT (SEQ ID NO: 67)	GCCCTAT TGCAAG CCCTCTT (SEQ ID NO: 68)	ACATTA TACAGC ATGCTG GcTAtc (SEQ ID NO: 229)	ACATT ATACA GCATG CTGGtT Aga (SEQ ID NO: 272)	GTTAA CATA TACAG CATGG TGGC (SEQ ID NO: 315)	CCCGT TGTTG TCATC GCATC (SEQ ID NO: 358)	GCCCT CATCT TCTTC CCTGC (SEQ ID NO: 33)
chr2	TTCCTCCACC GAACGTGTCT GAGGAAGAA AGTGAGgTTT Gc (SEQ ID NO: 101)	GCCCTATTGCA AGCCCTCTTGA GGAAGAAAGTG AGaTTGt (SEQ ID NO: 144)	GCAGAACATG TCCTGAAGCG TTCGATGCGT CCCATGAGTG CCCTCATCTTC TTCCTGc (SEQ ID NO: 187)	TTCCCTC CACCGA ACGTGT CT (SEQ ID NO: 67)	GCCCTAT TGCAAG CCCTCTT (SEQ ID NO: 68)	GAGGAA GAAAGT GAGgTT TGc (SEQ ID NO: 230)	GAGGA AGAAA GTGAG aTTTgT (SEQ ID NO: 273)	GCAG AACAT GTCTT GAAG C (SEQ ID NO: 316)	GTTCG ATGCG TCCCA TGAGT (SEQ ID NO: 359)	GCCCT CATCT TCTTC CCTGC (SEQ ID NO: 33)
chr15	TTCCTCCACC GAACGTGTCT CTGAATTATG TGCTTACCAaG AGc (SEQ ID NO: 102)	GCCCTATTGCA AGCCCTCTTCTG AATTATGTGCTT ACCAGAGt (SEQ ID NO: 145)	CAGTTGTTC CCA AACCCAT CAACCCGCGT AGATGTTCCT GCCCTCATCT TCTTCCCTGC (SEQ ID NO: 188)	TTCCCTC CACCGA ACGTGT CT (SEQ ID NO: 67)	GCCCTAT TGCAAG CCCTCTT (SEQ ID NO: 68)	CTGAAT TATGTG CTTACC AaGAGc (SEQ ID NO: 231)	CTGAA TTATGT GCTTA CCAaG AGt (SEQ ID NO: 274)	CAGCT TGTTT CCAAA CCCAT (SEQ ID NO: 317)	CAACC CGCGT AGATG TTCTT (SEQ ID NO: 360)	GCCCT CATCT TCTTC CCTGC (SEQ ID NO: 33)
chr9	TTCCTCCACC GAACGTGTCT TGGTCTGA TAACCTTATC AAgc (SEQ ID NO: 103)	GCCCTATTGCA AGCCCTCTTTGG GTTCTGATAAC CTTATCAAact (SEQ ID NO: 146)	CAAAGTGTGG AAGTTGCTTC CGCCAGCTCA AGAGGTAGC CGCCCTCATC TTCCTCCCTGC (SEQ ID NO: 189)	TTCCCTC CACCGA ACGTGT CT (SEQ ID NO: 67)	GCCCTAT TGCAAG CCCTCTT (SEQ ID NO: 68)	TGGGT CTGATA ACCTTA TCAAgc (SEQ ID NO: 232)	TGGGT TCTGA TAACC TTATC AAact (SEQ ID NO: 275)	CAA GTGTG GAAGT TGCTT CC (SEQ ID NO: 318)	GCCAG CTCAA GAGTG TAGCC (SEQ ID NO: 361)	GCCCT CATCT TCTTC CCTGC (SEQ ID NO: 33)
chr2	TTCCTCCACC GAACGTGTCT GGTTAGTCAA ACATGcTGc	GCCCTATTGCA AGCCCTCTTGGT TAGTCAAACAT GtTGT (SEQ ID	GGTCGACTTT GTCCATCCTT CTTGATCCTG CGCGATGTGC	TTCCCTC CACCGA ACGTGT CT (SEQ	GCCCTAT TGCAAG CCCTCTT (SEQ ID	GGTTAG TCAAAC ATGcTGc (SEQ ID	GGTTA GTCAA ACATGt Tgt	GGTCG ACTTT GTCCA TCC	TTCTT GATCC TGCGC GATGT	GCCCT CATCT TCTTC CCTGC

5  
10  
15  
20  
25  
30  
35  
40  
45  
50  
55

	(SEQ ID NO: 104)	NO: 147	CCTCATCTTCT TCCCTGC (SEQ ID NO: 190)	ID NO: 67)	NO: 68)	NO: 233)	(SEQ ID NO: 276)	(SEQ ID NO: 319)	(SEQ ID NO: 362)	(SEQ ID NO: 33)
chr17	TTCCTCCACC GAACGTGTCT GACACTGGCA GAATCAAATc Ac (SEQ ID NO: 105)	GCCCTATTGCA AGCCCTCTTGA CACTGGCAGAA TCAAAcCAa (SEQ ID NO: 148)	CTCTGTTGCC GTGGACTCAT CGCAGGCGTT CCCTATACGC CCTCATCTTCT TCCCTGC (SEQ ID NO: 191)	TTCCTC CACCGA ACGTGT CT (SEQ ID NO: 67)	GCCCTAT TGCAAG CCCTCTT (SEQ ID NO: 68)	GACACT GGCAGA ATCAAA tCAc (SEQ ID NO: 234)	GACAC TGGCA GAATC AAAcC Aa (SEQ ID NO: 277)	CTCTG TTGCC TGTGG ACTC (SEQ ID NO: 320)	ATCGC AGGC GTTCC CTATA C (SEQ ID NO: 363)	GCCCT CATCT TCTTC CCTGC (SEQ ID NO: 33)
chr6	TTCCTCCACC GAACGTGTCT AGAGTTACAC CTTTAGCTAA CcAc (SEQ ID NO: 106)	GCCCTATTGCA AGCCCTCTTAG AGTTACACCTTT AGCTAAcTag (SEQ ID NO: 149)	CTAACTAGAA TTAGTCTGCC TGCCATTGG ACCTCCGACC ACGAGCCCTC ATCTTCTTCCC TGC (SEQ ID NO: 192)	TTCCTC CACCGA ACGTGT CT (SEQ ID NO: 67)	GCCCTAT TGCAAG CCCTCTT (SEQ ID NO: 68)	AGAGTT ACACCT TTAGCT AACcAc (SEQ ID NO: 235)	AGAGT TACAC CTTTA GCTAA CAg (SEQ ID NO: 278)	CTAAC TAGAA TTAGT CTGCC TGCC (SEQ ID NO: 321)	TATTG GACCT CCGAC CACGA (SEQ ID NO: 364)	GCCCT CATCT TCTTC CCTGC (SEQ ID NO: 33)
chr7	TTCCTCCACC GAACGTGTCT CCAGGAGTTC AAGaAGCg (SEQ ID NO: 107)	GCCCTATTGCA AGCCCTCTTCCA GGAGTTCAAGg AGCa (SEQ ID NO: 150)	GTGAGCATA ATCGTGTCAA GCCACCAATT AGATCCGCGG CCCTCATCTTC TTCCCTGC (SEQ ID NO: 193)	TTCCTC CACCGA ACGTGT CT (SEQ ID NO: 67)	GCCCTAT TGCAAG CCCTCTT (SEQ ID NO: 68)	CCAGGA GTTCAA GaAGCg (SEQ ID NO: 236)	CCAGG AGTTC AAGaA GCa (SEQ ID NO: 279)	GTGAG CCATA ATCGT GTCA (SEQ ID NO: 322)	AGCCA CCATT TAGAT CCGCG (SEQ ID NO: 365)	GCCCT CATCT TCTTC CCTGC (SEQ ID NO: 33)
chr4	TTCCTCCACC GAACGTGTCT ACCACTCCTT TCTCCCaTCTc (SEQ ID NO: 108)	GCCCTATTGCA AGCCCTCTTACC ACTCCTTTCTCC CgTCTt (SEQ ID NO: 151)	GAGAAATTAAT GCTCCCTCTC CTGGACCAGT AGAAGCTCTG CCGGCCCTCA TCTTCTTCCCT GC (SEQ ID NO: 194)	TTCCTC CACCGA ACGTGT CT (SEQ ID NO: 67)	GCCCTAT TGCAAG CCCTCTT (SEQ ID NO: 68)	ACCACT CCTTTC TCCCaTC Tc (SEQ ID NO: 237)	ACCAC TCCTTT CTCCCG TCTt (SEQ ID NO: 280)	GAGA ATTAA TGCTC CCTCT CCTG (SEQ ID NO: 323)	GACCA GTAGA AGTCT GCCCG (SEQ ID NO: 366)	GCCCT CATCT TCTTC CCTGC (SEQ ID NO: 33)
chr2	TTCCTCCACC GAACGTGTCT	GCCCTATTGCA AGCCCTCTTGTc	GTGGTGTGCT GTTGACCAAT	TTCCTC CACCGA	GCCCTAT TGCAAG	GTCTTA TGGGAC	GTCTT ATGGG	GTGGT CTGCT	TTTCA GAATG	GCCCT CATCT

5  
10  
15  
20  
25  
30  
35  
40  
45  
50  
55

	GTCATTATGGG ACAATGGTG ATAg (SEQ ID NO: 109)	TTATGGGACAA TGGTcGATAt (SEQ ID NO: 152)	TTCAGAATGG CCGAGCTGTG CCCTCATCTTC TTCCTGc (SEQ ID NO: 195)	ACGTGT CT (SEQ ID NO: 67)	CCCTCTT (SEQ ID NO: 68)	AATGGT tGATAg (SEQ ID NO: 238)	ACAAT GGTcG ATAt (SEQ ID NO: 281)	GTTGA CCAA (SEQ ID NO: 324)	GCCGA GCTGT (SEQ ID NO: 367)	TCTTC CCTGC (SEQ ID NO: 33)
chr17	TTCCTCCACC GAACGTGTCT CTACCCTCAA CCCTCgTc (SEQ ID NO: 110)	GCCCTATTGCA AGCCCTCTTCTA CCCTCAACCCTC aTh (SEQ ID NO: 153)	GGTTGCAACT GCTGATCTAT AGGTGACCTT CTTGTACGCC GCCCTCATCT TCTTCCCTGC (SEQ ID NO: 196)	TTCCTC CACCGA ACGTGT CT (SEQ ID NO: 67)	GCCCTAT TGCAAG CCCTCTT (SEQ ID NO: 68)	CTACCC TCAACC CTCgTc (SEQ ID NO: 239)	CTACC CTCAA CCCTCa Tt (SEQ ID NO: 282)	GGTTG CAACT GCTGA TCTAT (SEQ ID NO: 325)	AGGTG ACCTT CTTGT ACGCC (SEQ ID NO: 368)	GCCCT CATCT TCTTC CCTGC (SEQ ID NO: 33)
chr7	TTCCTCCACC GAACGTGTCT CCAAGACTGA TCATGCcg (SEQ ID NO: 111)	GCCCTATTGCA AGCCCTCTTCCA AGACTGATCAT GCta (SEQ ID NO: 154)	CTTTCCCAGT CAAGGCAGGG CGGTCCTTA TTTCCATCGC CCTCATCTTCT TCCCTGC (SEQ ID NO: 197)	TTCCTC CACCGA ACGTGT CT (SEQ ID NO: 67)	GCCCTAT TGCAAG CCCTCTT (SEQ ID NO: 68)	CCAAGA CTGATC ATGCcg (SEQ ID NO: 240)	CCAAG ACTGA TCATG Cta (SEQ ID NO: 283)	CTTTC CCAGT CAAG GCAG (SEQ ID NO: 326)	GGCGC GTCCT TATTT CCATC (SEQ ID NO: 369)	GCCCT CATCT TCTTC CCTGC (SEQ ID NO: 33)

## EXAMPLES

**[0246]** The following protocol describes the processing of up to 24 cell-free DNA samples through hybridization-ligation, purification, amplification, microarray target preparation, microarray hybridization and microarray washing.

**[0247]** The following materials were prepared or obtained: Cell-free DNA (cfDNA) in a volume of 20  $\mu\text{L}$  water; Probe Mix: mixture of all Tagging and Labeling probe oligonucleotides at a concentration of 2 nM each; *Taq* Ligase (40 U/ $\mu\text{L}$ ); Magnetic Beads: MyOne Streptavidin C1 Dynabeads; Bead Binding and Washing Buffer, 1X and 2X concentrations; Forward amplification primer, 5' phosphate modified; Reverse amplification primer, labeled; AmpliTaq Gold Enzyme (5 U/ $\mu\text{L}$ ); dNTP Mix; Lambda Exonuclease (5 U/ $\mu\text{L}$ ); Hybridization Buffer, 1.25X; Hybridization control oligonucleotides; Microarray Wash Buffer A; Microarray Wash Buffer B; Microarray Wash Buffer C

**[0248] Hybridization-ligation Reaction:** The cfDNA samples (20  $\mu\text{L}$ ) were added to wells A3-H3 of a 96-well reaction plate. The following reagents were added to each cfDNA sample for a total reaction volume of 50  $\mu\text{L}$ , and mixed by pipetting up and down 5-8 times.

Component	Volume
H <sub>2</sub> O	19.33 $\mu\text{L}$
Probe Mix	5 $\mu\text{L}$
10X <i>Taq</i> Ligase Buffer	5 $\mu\text{L}$
<i>Taq</i> Ligase	0.67 $\mu\text{L}$

The plate was placed in a thermal cycler and ligate using the following cycling profile: (i) 95 °C for 5 minutes; (ii) 95 °C for 30 seconds; (iii) 45 °C for 25 minutes; (iv) Repeat steps b to c 4 times; and (v) 4 °C hold.

**Hybridization-ligation Product Purification:**

**[0249]** Wash Dynabeads: a vial of Dynabeads was vortexed at highest setting for 30 seconds. 260  $\mu\text{L}$  beads were transferred to a 1.5 mL tube. 900  $\mu\text{L}$  of 2X Bead Binding and Washing Buffer and mix beads were mixed by pipetting up and down 5-8 times. The tube was placed on a magnetic stand for 1 min, and the supernatant was discarded. The tube from the magnetic stand was removed and resuspended the washed magnetic beads in 900  $\mu\text{L}$  of 2X Bead Binding and Washing Buffer by pipetting up and down 5-8 times. The tube was placed on the magnetic stand for 1 min and discard the supernatant. The tube was removed from the magnetic stand and add 1,230  $\mu\text{L}$  of 2X Bead Binding and Washing Buffer. The beads were resuspended by pipetting up and down 5-8 times.

**[0250]** Immobilize HL Products: 50  $\mu\text{L}$  of washed beads was transferred to each hybridization-ligation reaction product in the 96-well reaction plate and mix by pipetting up and down 8 times, was incubated for 15 min at room temperature, mixed on a plate magnet twice during the incubation time. The beads were separated with on a plate magnet for 3 min and then remove and discard the supernatant. The plate was removed from the plate magnet, 200  $\mu\text{L}$  1X Bead Binding and Washing Buffer were added, and the beads were resuspended by pipetting up and down 5-8 times. The plate was placed on the plate magnet for 1 min, and the supernatant was discarded. The plate was removed from the plate magnet, 180  $\mu\text{L}$  1X SSC was added, and the beads were resuspended by pipetting up and down 5-8 times. The plate was placed on the plate magnet for 1 min, and the supernatant was discarded.

**[0251]** Purify Hyb-Ligation Products: 50  $\mu\text{L}$  of freshly prepared 0.15 M NaOH was added to each well and, the beads were resuspended by pipetting up and down 5-8 times, and incubated at room temperature for 10 minutes. The plate was placed on the plate magnet for 2 minutes and then was removed, and the supernatant was discarded. The plate was removed from the plate magnet, 200  $\mu\text{L}$  of freshly prepared 0.1 M NaOH was added, and the beads were resuspended by pipetting up and down 5-8 times. The plate was placed on the plate magnet for 1 min, and the supernatant was discarded. The plate was removed from the plate magnet, and 180  $\mu\text{L}$  0.1 M NaOH was added, and the beads were resuspended by pipetting up and down 5-8 times. The plate was placed on the plate magnet for 1 min, and the supernatant was discarded. The plate was removed from the plate magnet, 200  $\mu\text{L}$  of 1X Binding and Wash Buffer were added, and the beads were resuspended by pipetting up and down 5-8 times. Place the plate on the plate magnet for 1 min and discard the supernatant. Remove the plate from the plate magnet, add 180  $\mu\text{L}$  TE, and the beads were resuspended by pipetting up and down 5-8 times. The plate was placed on the plate magnet for 1 min, and the supernatant was discarded. 20  $\mu\text{L}$  water was added to each well and the beads were resuspended by pipetting up and down 5-8 times. The plate was sealed and store at 4 °C until used in subsequent steps.

**[0252] Amplification:** The following reagents were added to each hybridization-ligation reaction product in the 96-well reaction plate for a total reaction volume of 50  $\mu\text{L}$ .

EP 3 036 545 B1

Component	Volume
H2O	17.25 $\mu$ L
Forward Primer, 10 $\mu$ M	2.5 $\mu$ L
Reverse Primer, 10 $\mu$ M	2.5 $\mu$ L
4 mM dNTP Mix (L/N 052114)	2.5 $\mu$ L
10X AmpliTaq Gold Buffer	5 $\mu$ L
AmpliTaq Gold Enzyme	0.25 $\mu$ L

**[0253]** The plate was placed in a thermal cycler, and the probes were ligated using the following cycling profile: (i) 95 °C for 5 minutes; (ii) 95 °C for 30 seconds; (iii) 45 °C for 25 minutes; (iv) Repeat steps b to c 4 times; and (v) 4 °C hold.

**[0254]** Hybridization-ligation Product Purification: the reagents were mixed by pipetting up and down 5-8 times. The plate was placed in a thermal cycler, and the probes were amplified using the following cycling profile: (i) 95 °C for 5 minutes; (ii) 95 °C for 30 seconds; (iii) 54 °C for 30 seconds; (iv) 72 °C for 60 seconds, (v) Repeat steps b to d 29 times; (vi) 72 °C for 5 minutes; (vii) Repeat steps b to c 4 times; and (v) 4 °C hold.

**[0255] Microarray Target Preparation (single strand digestion):** the following reagents were added to each amplified reaction product in the 96-well reaction plate for a total reaction volume of 60  $\mu$ L.

Component	Volume
H2O	3 $\mu$ L
10X Lambda Exonuclease Buffer	6 $\mu$ L
Lambda Exonuclease Enzyme	1 $\mu$ L

**[0256]** The reagents were mixed by pipetting up and down 5-8 times. The plate was placed in a thermal cycler, and the probes were digested using the following cycling profile: (i) 37 °C for 60 minutes; (ii) 80 °C for 30 minutes; (iii) 4 °C hold. The plate was placed in Speed-vac and dry down samples using medium heat setting for about 60 minutes or until all liquid has evaporated. Samples were stored at 4 °C in the dark until used in subsequent steps.

**[0257] Microarray hybridization:** the following reagents were added to each dried Microarray Target in the 96-well reaction plate for a total reaction volume of 20  $\mu$ L.

Component	Volume
H <sub>2</sub> O	3 $\mu$ L
1.25X Hybridization Buffer	16 $\mu$ L
Hybridization control oligonucleotides	1 $\mu$ L

**[0258]** The reagents were mixed by pipetting up and down 10-20 times to be resuspended and were spun briefly to bring contents to the bottoms of the plate wells. The plate was placed in a thermal cycler, and the probes were denatured using the following cycling profile: (i) 70 °C for 3 minutes; (ii) 42 °C hold. The barcode of the microarray to be used was recorded for each sample in the Tracking Sheet. A hybridization chamber containing a Lifter Slip for each microarray to be processed is prepared. For each sample, 15  $\mu$ L of Microarray Target was added to the center of a Lifter Slip in a hybridization chamber, and the appropriate microarray was immediately placed onto the target fluid by placing the top edge down onto the lifter slip and slowly letting it fall down flat. The hybridization chambers were closed and incubated them at 42 °C for 60 minutes. The hybridization chambers were opened, and each microarray was removed from the Lifter Slips and placed into a rack immersed in Microarray Wash Buffer A. Once all the microarrays were in the rack, the rack was stirred at 650 rpm for 5 minutes. The rack of microarrays was removed from Microarray Wash Buffer A, excess liquid on a clean room wipe was tapped off, and the rack were quickly placed into Microarray Wash Buffer B. The rack was stirred at 650 rpm for 5 minutes. The rack of microarrays was removed from Microarray Wash Buffer B, excess liquid was tapped off on a clean room wipe, and the rack was quickly placed into Microarray Wash Buffer C. The rack was stirred at 650 rpm for 5 minutes. Immediately upon completion of the 5 minute wash in Microarray Wash Buffer C, the rack of microarrays was slowly removed from the buffer. This took 5-10 seconds to maximize the sheeting of the

## EP 3 036 545 B1

wash buffer from the cover slip surface. Excess liquid was tapped off on a clean room wipe. A vacuum aspirator was used to remove any remaining buffer droplets present on either surface of each microarray. The microarrays were stored in a slide rack under nitrogen and in the dark until the microarrays were analyzed.

### 5 SEQUENCE LISTING

#### [0259]

10 <110> SINGULAR BIO, INC. FEHR, Adrian Nielsen COLLINS, Patrick James HERSCHLEB, Jill Lyndon JONES,  
Hywel Bowden

<120> ASSAYS FOR SINGLE MOLECULE DETECTION AND USE THEREOF

15 <130> 31753-5003WO

<150> US 61/867,554

<151> 2013-08-19

20 <150> US 61/867,559

<151> 2013-08-19

<160> 369

25 <170> PatentIn version 3.5

<210> 1

<211> 60

<212> DNA

30 <213> Artificial Sequence

<220>

<223> Synthetic sequence

35 <400> 1

gcctcatct tctccctgc gtttcacca cctcaccaa ggaagaagtg agggcttctc 60

<210> 2

<211> 60

<212> DNA

40 <213> Artificial Sequence

<220>

<223> Synthetic sequence

45 <400> 2

gcctcatct tctccctgc gtttcacca cctcaccaa aatcaaggt gaccagctcc 60

<210> 3

<211> 62

50 <212> DNA

<213> Artificial Sequence

<220>

<223> Synthetic sequence

55 <400> 3

EP 3 036 545 B1

gccctcatct tcttcctgc gtttcacca ccctaccaa tcatctgcca agacagaagt 60

tc 62

5 <210> 4  
<211> 60  
<212> DNA  
<213> Artificial Sequence

10 <220>  
<223> Synthetic sequence

<400> 4  
15 gccctcatct tcttcctgc gtttcacca ccctaccaa gcaggagagt caaaggtctg 60

<210> 5  
<211> 60  
<212> DNA  
<213> Artificial Sequence

20 <220>  
<223> Synthetic sequence

<400> 5  
25 gccctcatct tcttcctgc gtttcacca ccctaccaa gttgcatgg agattgtgc 60

<210> 6  
<211> 60  
<212> DNA  
30 <213> Artificial Sequence

<220>  
<223> Synthetic sequence

<400> 6  
35 gccctcatct tcttcctgc gtttcacca ccctaccaa cagctcagtg atgtcattgc 60

<210> 7  
<211> 61  
40 <212> DNA  
<213> Artificial Sequence

<220>  
<223> Synthetic sequence

45 <400> 7

gccctcatct tcttcctgc gtttcacca ccctaccaa ccttgacctc tgctaattgtg 60

50 g 61

<210> 8  
<211> 60  
55 <212> DNA  
<213> Artificial Sequence

<220>

EP 3 036 545 B1

<223> Synthetic sequence

<400> 8  
5 gccctcatct tcttccctgc gtttcacca ccctcaccaa cacctgtcca acagctacag 60

<210> 9  
<211> 61  
<212> DNA  
<213> Artificial Sequence  
10

<220>  
<223> Synthetic sequence

<400> 9  
15

gccctcatct tcttccctgc gtttcacca ccctcaccaa agaatgtatc ttcaggcctg 60

c 61

<210> 10  
<211> 60  
<212> DNA  
<213> Artificial Sequence  
20

<220>  
<223> Synthetic sequence  
25

<400> 10  
30 gccctcatct tcttccctgc gtttcacca ccctcaccaa aagtaatcac tctgggtggc 60

<210> 11  
<211> 60  
<212> DNA  
<213> Artificial Sequence  
35

<220>  
<223> Synthetic sequence

<400> 11  
40 gccctcatct tcttccctgc gtttcacca ccctcaccaa agctcacaga caaccttg 60

<210> 12  
<211> 60  
<212> DNA  
<213> Artificial Sequence  
45

<220>  
<223> Synthetic sequence

<400> 12  
50 gccctcatct tcttccctgc gtttcacca ccctcaccaa gcaatagaca cctacaggcg 60

<210> 13  
<211> 60  
<212> DNA  
<213> Artificial Sequence  
55

<220>

EP 3 036 545 B1

<223> Synthetic sequence

<400> 13

gccctcatct tcttccctgc gtttcacca ccctcaccaa gacattatc aaaggccacg 60

5

<210> 14

<211> 60

<212> DNA

<213> Artificial Sequence

10

<220>

<223> Synthetic sequence

<400> 14

gccctcatct tcttccctgc gtttcacca ccctcaccaa caacgaccta aagcatgtgc 60

15

<210> 15

<211> 60

<212> DNA

<213> Artificial Sequence

20

<220>

<223> Synthetic sequence

<400> 15

gccctcatct tcttccctgc gtttcacca ccctcaccaa gacatacatg gctttggcag 60

25

<210> 16

<211> 62

<212> DNA

<213> Artificial Sequence

30

<220>

<223> Synthetic sequence

<400> 16

35

gccctcatct tcttccctgc gtttcacca ccctcaccaa gagatactgc cacttatgca 60

40

cg 62

<210> 17

<211> 40

<212> DNA

<213> Artificial Sequence

45

<220>

<223> Synthetic sequence

<400> 17

cgtgctaata gtctcagggc ttctccacc gaacgtgtct 40

50

<210> 18

<211> 40

<212> DNA

<213> Artificial Sequence

55

<220>  
 <223> Synthetic sequence  
  
 <400> 18  
 5 cgacgcttca ttgcttcatt ttctccacc gaacgtgtct 40  
  
 <210> 19  
 <211> 40  
 <212> DNA  
 10 <213> Artificial Sequence  
  
 <220>  
 <223> Synthetic sequence  
  
 <400> 19  
 15 cttgcgccaa acaattgtcc ttctccacc gaacgtgtct 40  
  
 <210> 20  
 <211> 40  
 20 <212> DNA  
 <213> Artificial Sequence  
  
 <220>  
 <223> Synthetic sequence  
 25  
 <400> 20  
 gctgcagagt ttgcattcat ttctccacc gaacgtgtct 40  
  
 <210> 21  
 <211> 41  
 30 <212> DNA  
 <213> Artificial Sequence  
  
 <220>  
 <223> Synthetic sequence  
 35  
 <400> 21  
 catacacaca gaccgagagt cttctccac cgaacgtgtc t 41  
  
 <210> 22  
 <211> 40  
 <212> DNA  
 <213> Artificial Sequence  
  
 <220>  
 <223> Synthetic sequence  
  
 <400> 22  
 50 ggatgtcagc cagcataagt ttctccacc gaacgtgtct 40  
  
 <210> 23  
 <211> 40  
 <212> DNA  
 <213> Artificial Sequence  
 55  
 <220>  
 <223> Synthetic sequence

EP 3 036 545 B1

<400> 23  
 gcaagtgcca aacagttctc ttcctccacc gaacgtgtct 40

5  
 <210> 24  
 <211> 41  
 <212> DNA  
 <213> Artificial Sequence

10  
 <220>  
 <223> Synthetic sequence

<400> 24  
 gattccagca cacttgagtc ttcctccac cgaacgtgtc t 41

15  
 <210> 25  
 <211> 40  
 <212> DNA  
 <213> Artificial Sequence

20  
 <220>  
 <223> Synthetic sequence

<400> 25  
 ccgtgcagg ttaaatggc gccctattgc aagccctct 40

25  
 <210> 26  
 <211> 40  
 <212> DNA  
 <213> Artificial Sequence

30  
 <220>  
 <223> Synthetic sequence

<400> 26  
 caagatgct ttatggcct gccctattgc aagccctct 40

35  
 <210> 27  
 <211> 41  
 <212> DNA  
 <213> Artificial Sequence

40  
 <220>  
 <223> Synthetic sequence

<400> 27  
 gcactcaagg agatcagact ggcctattg caagccctct t 41

45  
 <210> 28  
 <211> 41  
 <212> DNA  
 <213> Artificial Sequence

50  
 <220>  
 <223> Synthetic sequence

<400> 28  
 ggctatcgaa ctacaaccac agccctattg caagccctct t 41

55

EP 3 036 545 B1

<210> 29  
<211> 41  
<212> DNA  
<213> Artificial Sequence  
5  
<220>  
<223> Synthetic sequence  
<400> 29  
10 gtagctgtct gtggtgtgat cgccctattg caagccctct t 41  
<210> 30  
<211> 42  
<212> DNA  
15 <213> Artificial Sequence  
<220>  
<223> Synthetic sequence  
20 <400> 30  
caagaaact cgagccttag cagccctatt gcaagccctc tt 42  
<210> 31  
<211> 40  
25 <212> DNA  
<213> Artificial Sequence  
<220>  
<223> Synthetic sequence  
30 <400> 31  
gtgaaccagt ccgagtgaaa gcctattgc aagccctctt 40  
<210> 32  
35 <211> 41  
<212> DNA  
<213> Artificial Sequence  
<220>  
40 <223> Synthetic sequence  
<400> 32  
gcaaattgatg ttcagcacca cgccctattg caagccctct t 41  
<210> 33  
<211> 20  
<212> DNA  
<213> Artificial Sequence  
50 <220>  
<223> Synthetic sequence  
<400> 33  
55 gccctcatct tcttcctgc 20  
<210> 34  
<211> 20  
<212> DNA

EP 3 036 545 B1

<213> Artificial Sequence

<220>  
<223> Synthetic sequence

5

<400> 34  
gttctacca ccctaccaa 20

<210> 35  
<211> 20  
<212> DNA  
<213> Artificial Sequence

10

<220>  
<223> Synthetic sequence

15

<400> 35  
ggaagaagtg agggctctc 20

20

<210> 36  
<211> 20  
<212> DNA  
<213> Artificial Sequence

25

<220>  
<223> Synthetic sequence

30

<400> 36  
aatcaaggt gaccagctcc 20

35

<210> 37  
<211> 22  
<212> DNA  
<213> Artificial Sequence

40

<220>  
<223> Synthetic sequence

45

<400> 37  
tcatctgcc aagacagaagtc 22

<210> 38  
<211> 20  
<212> DNA  
<213> Artificial Sequence

50

<220>  
<223> Synthetic sequence

55

<400> 38  
gcaggagagt caaaggctctg 20

<210> 39  
<211> 20  
<212> DNA  
<213> Artificial Sequence

<220>

<223> Synthetic sequence  
  
 <400> 39  
 gttgccatgg agattgttc 20  
 5  
  
 <210> 40  
 <211> 20  
 <212> DNA  
 <213> Artificial Sequence  
 10  
  
 <220>  
 <223> Synthetic sequence  
  
 <400> 40  
 cagctcagtg atgtcattgc 20  
 15  
  
 <210> 41  
 <211> 21  
 <212> DNA  
 <213> Artificial Sequence  
 20  
  
 <220>  
 <223> Synthetic sequence  
  
 <400> 41  
 ccttgacctc tgctaattg g 21  
 25  
  
 <210> 42  
 <211> 20  
 <212> DNA  
 <213> Artificial Sequence  
 30  
  
 <220>  
 <223> Synthetic sequence  
 35  
  
 <400> 42  
 cacctgtcca acagctacag 20  
  
 <210> 43  
 <211> 21  
 <212> DNA  
 <213> Artificial Sequence  
 40  
  
 <220>  
 <223> Synthetic sequence  
 45  
  
 <400> 43  
 agaattgtatc tcaggcctg c 21  
  
 <210> 44  
 <211> 20  
 <212> DNA  
 <213> Artificial Sequence  
 50  
  
 <220>  
 <223> Synthetic sequence  
 55  
  
 <400> 44

EP 3 036 545 B1

aagtaatcac tctgggtggc 20

<210> 45  
 <211> 20  
 5 <212> DNA  
 <213> Artificial Sequence

<220>  
 <223> Synthetic sequence

10 <400> 45  
 agctcacaga caacctgtg 20

<210> 46  
 15 <211> 20  
 <212> DNA  
 <213> Artificial Sequence

<220>  
 20 <223> Synthetic sequence

<400> 46  
 gcaatagaca cctacaggcg 20

25 <210> 47  
 <211> 20  
 <212> DNA  
 <213> Artificial Sequence

30 <220>  
 <223> Synthetic sequence

<400> 47  
 35 gcacattatc aaaggccacg 20

<210> 48  
 <211> 20  
 <212> DNA  
 <213> Artificial Sequence

40 <220>  
 <223> Synthetic sequence

<400> 48  
 45 caacgaccta aagcatgtgc 20

<210> 49  
 <211> 20  
 <212> DNA  
 50 <213> Artificial Sequence

<220>  
 <223> Synthetic sequence

55 <400> 49  
 gacatacatg gcttggcag 20

<210> 50

<211> 22  
 <212> DNA  
 <213> Artificial Sequence  
 5 <220>  
 <223> Synthetic sequence  
 <400> 50  
 gagatactgc cacttatgca cg 22  
 10  
 <210> 51  
 <211> 20  
 <212> DNA  
 <213> Artificial Sequence  
 15  
 <220>  
 <223> Synthetic sequence  
 <400> 51  
 20 cgtgctaata gtctcagggc 20  
 <210> 52  
 <211> 20  
 <212> DNA  
 25 <213> Artificial Sequence  
 <220>  
 <223> Synthetic sequence  
 30 <400> 52  
 cgacgcttca ttgcttcatt 20  
 <210> 53  
 <211> 20  
 35 <212> DNA  
 <213> Artificial Sequence  
 <220>  
 <223> Synthetic sequence  
 40  
 <400> 53  
 cttgcgccaa acaattgtcc 20  
 <210> 54  
 45 <211> 20  
 <212> DNA  
 <213> Artificial Sequence  
 <220>  
 50 <223> Synthetic sequence  
 <400> 54  
 gctgcagagt ttgcattcat 20  
 55  
 <210> 55  
 <211> 21  
 <212> DNA  
 <213> Artificial Sequence

<220>  
 <223> Synthetic sequence  
  
 <400> 55  
 5 catacacaca gaccgagagt c 21  
  
 <210> 56  
 <211> 20  
 <212> DNA  
 10 <213> Artificial Sequence  
  
 <220>  
 <223> Synthetic sequence  
  
 <400> 56  
 15 ggatgtcagc cagcataagt 20  
  
 <210> 57  
 <211> 20  
 20 <212> DNA  
 <213> Artificial Sequence  
  
 <220>  
 <223> Synthetic sequence  
 25  
 <400> 57  
 gcaagtgcca aacagttctc 20  
  
 <210> 58  
 <211> 21  
 30 <212> DNA  
 <213> Artificial Sequence  
  
 <220>  
 <223> Synthetic sequence  
 35  
 <400> 58  
 gattccagca cacttgagtc t 21  
  
 <210> 59  
 <211> 20  
 <212> DNA  
 <213> Artificial Sequence  
  
 <220>  
 <223> Synthetic sequence  
  
 <400> 59  
 50 ccgtgcagg tttaatggc 20  
  
 <210> 60  
 <211> 20  
 <212> DNA  
 <213> Artificial Sequence  
 55  
 <220>  
 <223> Synthetic sequence

EP 3 036 545 B1

<400> 60  
 caagagtgct ttatggcct 20

5  
 <210> 61  
 <211> 21  
 <212> DNA  
 <213> Artificial Sequence

10  
 <220>  
 <223> Synthetic sequence

<400> 61  
 gcactcaagg agatcagact g 21

15  
 <210> 62  
 <211> 21  
 <212> DNA  
 <213> Artificial Sequence

20  
 <220>  
 <223> Synthetic sequence

<400> 62  
 ggctatcgaa ctacaaccac a 21

25  
 <210> 63  
 <211> 21  
 <212> DNA  
 <213> Artificial Sequence

30  
 <220>  
 <223> Synthetic sequence

<400> 63  
 gtagctgtct gtggtgtgat c 21

35  
 <210> 64  
 <211> 22  
 <212> DNA  
 <213> Artificial Sequence

40  
 <220>  
 <223> Synthetic sequence

<400> 64  
 caagaaact cgagccttag ca 22

45  
 <210> 65  
 <211> 20  
 <212> DNA  
 <213> Artificial Sequence

50  
 <220>  
 <223> Synthetic sequence

55  
 <400> 65  
 gtgaaccagt ccgagtgaaa 20

<210> 66  
 <211> 21  
 <212> DNA  
 <213> Artificial Sequence  
 5  
 <220>  
 <223> Synthetic sequence  
 <400> 66  
 10 gcaaatgatg ttcagcacca c 21  
 <210> 67  
 <211> 20  
 <212> DNA  
 15 <213> Artificial Sequence  
 <220>  
 <223> Synthetic sequence  
 20 <400> 67  
 ttctccacc gaacgtgtct 20  
 <210> 68  
 <211> 20  
 25 <212> DNA  
 <213> Artificial Sequence  
 <220>  
 <223> Synthetic sequence  
 30 <400> 68  
 gccctattgc aagcccttt 20  
 <210> 69  
 <211> 40  
 35 <212> DNA  
 <213> Artificial Sequence  
 <220>  
 40 <223> Synthetic sequence  
 <400> 69  
 ttctccacc gaacgtgtct agaccagcac aacttactcg 40  
 45 <210> 70  
 <211> 37  
 <212> DNA  
 <213> Artificial Sequence  
 50 <220>  
 <223> Synthetic sequence  
 <400> 70  
 55 ttctccacc gaacgtgtct ccaaatgcac ctgcctg 37  
 <210> 71  
 <211> 41  
 <212> DNA

EP 3 036 545 B1

<213> Artificial Sequence

<220>  
<223> Synthetic sequence

5

<400> 71  
ttctccacc gaacgtgtct agttggaca aaggcaattc g 41

<210> 72  
<211> 44  
<212> DNA  
<213> Artificial Sequence

10

<220>  
<223> Synthetic sequence

15

<400> 72  
ttctccacc gaacgtgtct tgagcttagc caatatcaag aagg 44

20

<210> 73  
<211> 42  
<212> DNA  
<213> Artificial Sequence

25

<220>  
<223> Synthetic sequence

<400> 73  
ttctccacc gaacgtgtct acgtgaactt tccttggtac ac 42

30

<210> 74  
<211> 44  
<212> DNA  
<213> Artificial Sequence

35

<220>  
<223> Synthetic sequence

<400> 74  
ttctccacc gaacgtgtct tgaagatggt ctaatacctt gccg 44

40

<210> 75  
<211> 38  
<212> DNA  
<213> Artificial Sequence

45

<220>  
<223> Synthetic sequence

<400> 75  
ttctccacc gaacgtgtct cagtgtggag actgaacg 38

50

<210> 76  
<211> 43  
<212> DNA  
<213> Artificial Sequence

55

<220>

<223> Synthetic sequence

<400> 76  
 5 ttctccacc gaacgtgtct aggcagggta atgtcatgaa atg 43

<210> 77  
 <211> 37  
 <212> DNA  
 <213> Artificial Sequence

10 <220>  
 <223> Synthetic sequence

<400> 77  
 15 ttctccacc gaacgtgtct gattgtctgg agcgctg 37

<210> 78  
 <211> 36  
 <212> DNA  
 20 <213> Artificial Sequence

<220>  
 <223> Synthetic sequence

25 <400> 78  
 ttctccacc gaacgtgtct agggagcaat aggccg 36

<210> 79  
 <211> 37  
 <212> DNA  
 30 <213> Artificial Sequence

<220>  
 <223> Synthetic sequence

35 <400> 79  
 ttctccacc gaacgtgtct ctgcagggta caacacg 37

<210> 80  
 <211> 38  
 <212> DNA  
 40 <213> Artificial Sequence

<220>  
 <223> Synthetic sequence

45 <400> 80  
 ttctccacc gaacgtgtct cgtatctggg aagacggc 38

<210> 81  
 <211> 40  
 <212> DNA  
 <213> Artificial Sequence

50 <220>  
 <223> Synthetic sequence

55 <400> 81

EP 3 036 545 B1

ttctccacc gaacgtgtct cctgtaatcc cttgcaatgc 40

<210> 82  
<211> 38  
5 <212> DNA  
<213> Artificial Sequence

<220>  
10 <223> Synthetic sequence

<400> 82  
ttctccacc gaacgtgtct ggtctcagca cggttctg 38

<210> 83  
15 <211> 37  
<212> DNA  
<213> Artificial Sequence

<220>  
20 <223> Synthetic sequence

<400> 83  
ttctccacc gaacgtgtct gcacctcctt accacac 37

25 <210> 84  
<211> 41  
<212> DNA  
<213> Artificial Sequence

30 <220>  
<223> Synthetic sequence

<400> 84  
35 ttctccacc gaacgtgtct gcctctagct agagagaagt c 41

<210> 85  
<211> 39  
<212> DNA  
<213> Artificial Sequence

40 <220>  
<223> Synthetic sequence

<400> 85  
45 ttctccacc gaacgtgtct ctggcagtct agccgttac 39

<210> 86  
<211> 43  
<212> DNA  
50 <213> Artificial Sequence

<220>  
<223> Synthetic sequence

55 <400> 86  
ttctccacc gaacgtgtct tgtcttagaa ttggcaact ggc 43

<210> 87

<211> 39  
 <212> DNA  
 <213> Artificial Sequence  
 5 <220>  
 <223> Synthetic sequence  
 <400> 87  
 10 ttctccacc gaacgtgtct gcaggaaagc ctactgaac 39  
 <210> 88  
 <211> 39  
 <212> DNA  
 <213> Artificial Sequence  
 15 <220>  
 <223> Synthetic sequence  
 <400> 88  
 20 ttctccacc gaacgtgtct gggagccaga gaaatgtcc 39  
 <210> 89  
 <211> 44  
 <212> DNA  
 25 <213> Artificial Sequence  
 <220>  
 <223> Synthetic sequence  
 30 <400> 89  
 ttctccacc gaacgtgtct tgtctccagt tccactcat ttag 44  
 <210> 90  
 <211> 39  
 35 <212> DNA  
 <213> Artificial Sequence  
 <220>  
 <223> Synthetic sequence  
 40 <400> 90  
 ttctccacc gaacgtgtct cccgtaatt gcctactcg 39  
 <210> 91  
 45 <211> 38  
 <212> DNA  
 <213> Artificial Sequence  
 <220>  
 50 <223> Synthetic sequence  
 <400> 91  
 ttctccacc gaacgtgtct ctcggtccca ctggaag 38  
 55 <210> 92  
 <211> 41  
 <212> DNA  
 <213> Artificial Sequence

EP 3 036 545 B1

<220>  
<223> Synthetic sequence

<400> 92  
5 ttctccacc gaacgtgtct acacccatga ttcagttact g 41

<210> 93  
<211> 41  
<212> DNA  
10 <213> Artificial Sequence

<220>  
<223> Synthetic sequence

<400> 93  
15 ttctccacc gaacgtgtct gctagtatga acatcacagg c 41

<210> 94  
<211> 43  
20 <212> DNA  
<213> Artificial Sequence

<220>  
<223> Synthetic sequence

<400> 94  
25 ttctccacc gaacgtgtct acaaatgagt aagaagcgag tcg 43

<210> 95  
<211> 38  
30 <212> DNA  
<213> Artificial Sequence

<220>  
<223> Synthetic sequence

<400> 95  
35 ttctccacc gaacgtgtct gataagggtt gctctgcg 38

<210> 96  
<211> 37  
40 <212> DNA  
<213> Artificial Sequence

<220>  
<223> Synthetic sequence

<400> 96  
45 ttctccacc gaacgtgtct ccatgcacca gctaccc 37

<210> 97  
<211> 40  
50 <212> DNA  
<213> Artificial Sequence

<220>  
<223> Synthetic sequence

55

EP 3 036 545 B1

<400> 97  
ttctccacc gaacgtgtct aactgtaccc tactcccagc 40

5  
<210> 98  
<211> 41  
<212> DNA  
<213> Artificial Sequence

10  
<220>  
<223> Synthetic sequence

<400> 98  
ttctccacc gaacgtgtct aggaccaagg gaccagtta g 41

15  
<210> 99  
<211> 42  
<212> DNA  
<213> Artificial Sequence

20  
<220>  
<223> Synthetic sequence

<400> 99  
ttctccacc gaacgtgtct agagttcctc caagaaattg cg 42

25  
<210> 100  
<211> 44  
<212> DNA  
<213> Artificial Sequence

30  
<220>  
<223> Synthetic sequence

<400> 100  
ttctccacc gaacgtgtct acattataca gcatgctggc tatc 44

35  
<210> 101  
<211> 41  
<212> DNA  
<213> Artificial Sequence

40  
<220>  
<223> Synthetic sequence

45  
<400> 101  
ttctccacc gaacgtgtct gaggaagaaa gtgaggttg c 41

50  
<210> 102  
<211> 44  
<212> DNA  
<213> Artificial Sequence

55  
<220>  
<223> Synthetic sequence

<400> 102  
ttctccacc gaacgtgtct ctgaattatg tgcttaccaa gagc 44

EP 3 036 545 B1

<210> 103  
<211> 44  
<212> DNA  
<213> Artificial Sequence  
5  
<220>  
<223> Synthetic sequence  
  
<400> 103  
10 ttctccacc gaacgtgtct tgggttctga taacctatc aagc 44  
  
<210> 104  
<211> 39  
<212> DNA  
15 <213> Artificial Sequence  
  
<220>  
<223> Synthetic sequence  
  
20 <400> 104  
ttctccacc gaacgtgtct ggtagtcaa acatgctgc 39  
  
<210> 105  
<211> 42  
25 <212> DNA  
<213> Artificial Sequence  
  
<220>  
<223> Synthetic sequence  
30  
  
<400> 105  
ttctccacc gaacgtgtct gacctggca gaatcaaac ac 42  
  
<210> 106  
<211> 44  
35 <212> DNA  
<213> Artificial Sequence  
  
<220>  
40 <223> Synthetic sequence  
  
<400> 106  
ttctccacc gaacgtgtct agagttacac cttagctaa ccac 44  
  
45 <210> 107  
<211> 38  
<212> DNA  
<213> Artificial Sequence  
  
50 <220>  
<223> Synthetic sequence  
  
<400> 107  
55 ttctccacc gaacgtgtct ccaggagttc aagaagcg 38  
  
<210> 108  
<211> 41  
<212> DNA

EP 3 036 545 B1

<213> Artificial Sequence

<220>  
<223> Synthetic sequence

5

<400> 108  
ttctccacc gaacgtgtct accactcctt tctccatct c 41

<210> 109  
<211> 44  
<212> DNA  
<213> Artificial Sequence

10

<220>  
<223> Synthetic sequence

15

<400> 109  
ttctccacc gaacgtgtct gtcttatggg acaatggtg atag 44

20

<210> 110  
<211> 38  
<212> DNA  
<213> Artificial Sequence

25

<220>  
<223> Synthetic sequence

30

<400> 110  
ttctccacc gaacgtgtct ctaccctcaa ccctcgtc 38

35

<210> 111  
<211> 38  
<212> DNA  
<213> Artificial Sequence

40

<220>  
<223> Synthetic sequence

45

<400> 111  
ttctccacc gaacgtgtct ccaagactga tcatgccg 38

<210> 112  
<211> 40  
<212> DNA  
<213> Artificial Sequence

50

<220>  
<223> Synthetic sequence

55

<400> 112  
gccctatgc aagccctctt agaccagcac aactactta 40

<210> 113  
<211> 37  
<212> DNA  
<213> Artificial Sequence

<220>

EP 3 036 545 B1

<223> Synthetic sequence

<400> 113  
5 gccctattgc aagccctctt ccaaattcac ctgccca 37

<210> 114  
<211> 41  
<212> DNA  
<213> Artificial Sequence  
10

<220>  
<223> Synthetic sequence

<400> 114  
15 gccctattgc aagccctctt agtttgaca aaggcgatt a 41

<210> 115  
<211> 44  
<212> DNA  
20 <213> Artificial Sequence

<220>  
<223> Synthetic sequence

<400> 115  
25 gccctattgc aagccctctt tgagcttagc caatatcaac aaga 44

<210> 116  
<211> 42  
30 <212> DNA  
<213> Artificial Sequence

<220>  
<223> Synthetic sequence  
35

<400> 116  
gccctattgc aagccctctt acgtgaactt tccttgtaa at 42

<210> 117  
40 <211> 44  
<212> DNA  
<213> Artificial Sequence

<220>  
45 <223> Synthetic sequence

<400> 117  
gccctattgc aagccctctt tgaagatgtt ctaatacctt gcta 44

<210> 118  
50 <211> 38  
<212> DNA  
<213> Artificial Sequence

<220>  
55 <223> Synthetic sequence

<400> 118

EP 3 036 545 B1

gccctattgc aagccctctt cagtgtggag accgaaca 38

<210> 119  
<211> 43  
5 <212> DNA  
<213> Artificial Sequence

<220>  
10 <223> Synthetic sequence

<400> 119  
gccctattgc aagccctctt aggcagggta atgcatgaa gtt 43

<210> 120  
15 <211> 37  
<212> DNA  
<213> Artificial Sequence

<220>  
20 <223> Synthetic sequence

<400> 120  
gccctattgc aagccctctt gattgtctgg agggctc 37

<210> 121  
25 <211> 36  
<212> DNA  
<213> Artificial Sequence

<220>  
30 <223> Synthetic sequence

<400> 121  
35 gccctattgc aagccctctt agggagcaat aggcta 36

<210> 122  
<211> 37  
<212> DNA  
<213> Artificial Sequence

<220>  
40 <223> Synthetic sequence

<400> 122  
45 gccctattgc aagccctctt ctgcagggta caagaca 37

<210> 123  
<211> 38  
<212> DNA  
50 <213> Artificial Sequence

<220>  
<223> Synthetic sequence

<400> 123  
55 gccctattgc aagccctctt cgtatctggg aagatggg 38

<210> 124

<211> 40  
 <212> DNA  
 <213> Artificial Sequence

5

<220>  
 <223> Synthetic sequence

<400> 124  
 gccctattgc aagccctctt cctgtaatcc cttgcaataa 40

10

<210> 125  
 <211> 38  
 <212> DNA  
 <213> Artificial Sequence

15

<220>  
 <223> Synthetic sequence

<400> 125  
 gccctattgc aagccctctt ggtctcagca cggtcctt 38

20

<210> 126  
 <211> 37  
 <212> DNA  
 <213> Artificial Sequence

25

<220>  
 <223> Synthetic sequence

<400> 126  
 gccctattgc aagccctctt gcacctcctt atcacat 37

30

<210> 127  
 <211> 41  
 <212> DNA  
 <213> Artificial Sequence

35

<220>  
 <223> Synthetic sequence

40

<400> 127  
 gccctattgc aagccctctt gcctctagct agagagaagc g 41

45

<210> 128  
 <211> 39  
 <212> DNA  
 <213> Artificial Sequence

50

<220>  
 <223> Synthetic sequence

<400> 128  
 gccctattgc aagccctctt ctggcagtct agccattat 39

55

<210> 129  
 <211> 43  
 <212> DNA  
 <213> Artificial Sequence

EP 3 036 545 B1

<220>  
<223> Synthetic sequence

5 <400> 129  
gccctattgc aagccctctt tgtcttagaa ttggcaact agt 43

<210> 130  
<211> 39  
<212> DNA  
10 <213> Artificial Sequence

<220>  
<223> Synthetic sequence

15 <400> 130  
gccctattgc aagccctctt gcaggaaagc ctattgaat 39

<210> 131  
<211> 39  
20 <212> DNA  
<213> Artificial Sequence

<220>  
<223> Synthetic sequence

25 <400> 131  
gccctattgc aagccctctt gggagccaga gaaattct 39

<210> 132  
<211> 44  
30 <212> DNA  
<213> Artificial Sequence

<220>  
<223> Synthetic sequence

35 <400> 132  
gccctattgc aagccctctt tgtctccagt tccactcat gtaa 44

<210> 133  
<211> 39  
<212> DNA  
<213> Artificial Sequence

45 <220>  
<223> Synthetic sequence

<400> 133  
50 gccctattgc aagccctctt cccgtaatt gcctatta 39

<210> 134  
<211> 38  
<212> DNA  
<213> Artificial Sequence

55 <220>  
<223> Synthetic sequence

EP 3 036 545 B1

<400> 134  
gccctattgc aagccctctt ctcggtccca ctgggaaa 38

5  
<210> 135  
<211> 41  
<212> DNA  
<213> Artificial Sequence

10  
<220>  
<223> Synthetic sequence

<400> 135  
gccctattgc aagccctctt acacccatga ttcagttacc a 41

15  
<210> 136  
<211> 41  
<212> DNA  
<213> Artificial Sequence

20  
<220>  
<223> Synthetic sequence

<400> 136  
gccctattgc aagccctctt gctagatga acatcacaag t 41

25  
<210> 137  
<211> 43  
<212> DNA  
<213> Artificial Sequence

30  
<220>  
<223> Synthetic sequence

<400> 137  
gccctattgc aagccctctt acaaatgagt aagaagcgag tta 43

35  
<210> 138  
<211> 38  
<212> DNA  
<213> Artificial Sequence

40  
<220>  
<223> Synthetic sequence

45  
<400> 138  
gccctattgc aagccctctt gataagggtt gctctaca 38

<210> 139  
<211> 37  
<212> DNA  
<213> Artificial Sequence

50  
<220>  
<223> Synthetic sequence

55  
<400> 139  
gccctattgc aagccctctt ccatgcacca gctacta 37

<210> 140  
 <211> 40  
 <212> DNA  
 <213> Artificial Sequence  
 5  
 <220>  
 <223> Synthetic sequence  
 <400> 140  
 10 gccctattgc aagccctctt aactgtaccc tactccaat 40  
 <210> 141  
 <211> 41  
 <212> DNA  
 15 <213> Artificial Sequence  
 <220>  
 <223> Synthetic sequence  
 20 <400> 141  
 gccctattgc aagccctctt aggaccaagg gaccagtca c 41  
 <210> 142  
 <211> 42  
 25 <212> DNA  
 <213> Artificial Sequence  
 <220>  
 <223> Synthetic sequence  
 30 <400> 142  
 gccctattgc aagccctctt agagttctc caagaaattg ta 42  
 <210> 143  
 <211> 44  
 35 <212> DNA  
 <213> Artificial Sequence  
 <220>  
 <223> Synthetic sequence  
 40 <400> 143  
 gccctattgc aagccctctt acattataca gcatgctggt taga 44  
 <210> 144  
 <211> 41  
 <212> DNA  
 <213> Artificial Sequence  
 45 <220>  
 <223> Synthetic sequence  
 <400> 144  
 50 gccctattgc aagccctctt gaggaagaaa gtgagattg t 41  
 55 <210> 145  
 <211> 44  
 <212> DNA

EP 3 036 545 B1

<213> Artificial Sequence

<220>  
<223> Synthetic sequence

5

<400> 145  
gccctattgc aagccctctt ctgaattatg tgcttaccag gagt 44

<210> 146  
<211> 44  
<212> DNA  
<213> Artificial Sequence

10

<220>  
<223> Synthetic sequence

15

<400> 146  
gccctattgc aagccctctt tgggttctga taacctatc aact 44

20

<210> 147  
<211> 39  
<212> DNA  
<213> Artificial Sequence

25

<220>  
<223> Synthetic sequence

30

<400> 147  
gccctattgc aagccctctt ggtagtcaa acatgtgt 39

35

<210> 148  
<211> 42  
<212> DNA  
<213> Artificial Sequence

40

<220>  
<223> Synthetic sequence

45

<400> 148  
gccctattgc aagccctctt gacctggca gaatcaaacc aa 42

<210> 149  
<211> 44  
<212> DNA  
<213> Artificial Sequence

50

<220>  
<223> Synthetic sequence

55

<400> 149  
gccctattgc aagccctctt agagttacac cttagctaa ctag 44

<210> 150  
<211> 38  
<212> DNA  
<213> Artificial Sequence

<220>

EP 3 036 545 B1

<223> Synthetic sequence

<400> 150  
5 gccctattgc aagccctctt ccaggagttc aaggagca 38

<210> 151  
<211> 41  
<212> DNA  
<213> Artificial Sequence

10 <220>  
<223> Synthetic sequence

<400> 151  
15 gccctattgc aagccctctt accactcctt tctcccgtct t 41

<210> 152  
<211> 44  
<212> DNA  
20 <213> Artificial Sequence

<220>  
<223> Synthetic sequence

25 <400> 152  
gccctattgc aagccctctt gtcttatggg acaatggtcg atat 44

<210> 153  
<211> 38  
30 <212> DNA  
<213> Artificial Sequence

<220>  
<223> Synthetic sequence

35 <400> 153  
gccctattgc aagccctctt ctaccctcaa ccctcatt 38

<210> 154  
40 <211> 38  
<212> DNA  
<213> Artificial Sequence

<220>  
45 <223> Synthetic sequence

<400> 154  
gccctattgc aagccctctt ccaagactga tcatgcta 38

<210> 155  
50 <211> 61  
<212> DNA  
<213> Artificial Sequence

55 <220>  
<223> Synthetic sequence

<400> 155

EP 3 036 545 B1

	<b>cacttgacaa agttctcacg cgccgaagtt ctccgaagga tgcctcatc ttcttcctg</b>	<b>60</b>
	<b>c</b>	<b>61</b>
5	<210> 156 <211> 61 <212> DNA <213> Artificial Sequence	
10	<220> <223> Synthetic sequence	
	<400> 156	
15	<b>cattagggat taacggcttg ggacagactg acggagcttc agccctcatc ttcttcctg</b>	<b>60</b>
	<b>c</b>	<b>61</b>
20	<210> 157 <211> 63 <212> DNA <213> Artificial Sequence	
25	<220> <223> Synthetic sequence	
	<400> 157	
30	<b>cacacgtaa gaagactttc tgctgactct gccgcacatg atgccctca tcttctccc</b>	<b>60</b>
	<b>tgc</b>	<b>63</b>
35	<210> 158 <211> 62 <212> DNA <213> Artificial Sequence	
40	<220> <223> Synthetic sequence	
	<400> 158	
45	<b>ctaagtgcc tccatgagaa aggatccgat agccctctgc agccctcat cttcttcct</b>	<b>60</b>
	<b>gc</b>	<b>62</b>
50	<210> 159 <211> 60 <212> DNA <213> Artificial Sequence	
55	<220> <223> Synthetic sequence	
	<400> 159 gcacagatt cccacactct caacaggcct gctaacacc gccctcatct tcttcctgc	60

EP 3 036 545 B1

<210> 160  
<211> 61  
<212> DNA  
<213> Artificial Sequence  
5  
<220>  
<223> Synthetic sequence  
10  
<400> 160  
cttacaggag gtctggcatc aggtcaacaa ccgagggact cgcctcatc ttcttcctg 60  
c 61  
15  
<210> 161  
<211> 59  
<212> DNA  
<213> Artificial Sequence  
20  
<220>  
<223> Synthetic sequence  
<400> 161  
ccacaatgag aaggcagagt tgcattaat gctggcggcg ccctcatctt ctccctgc 59  
25  
<210> 162  
<211> 60  
<212> DNA  
<213> Artificial Sequence  
30  
<220>  
<223> Synthetic sequence  
<400> 162  
gctgtggcat agtacactc cggtagcggg ttgcaactt gccctcatct tcttcctgc 60  
35  
<210> 163  
<211> 60  
<212> DNA  
<213> Artificial Sequence  
40  
<220>  
<223> Synthetic sequence  
45  
<400> 163  
cagggaatt tgtgggtctg gtccggcagt taagggtctc gccctcatct tcttcctgc 60  
50  
<210> 164  
<211> 62  
<212> DNA  
<213> Artificial Sequence  
55  
<220>  
<223> Synthetic sequence  
<400> 164

EP 3 036 545 B1

	gggctatcca gaaagataag aatactcaca aacgactgcg cagccctcat cttcttcct	60
	gc	62
5	<210> 165 <211> 63 <212> DNA <213> Artificial Sequence	
10	<220> <223> Synthetic sequence	
15	<400> 165	
	cataactggg ggagtatttc actcgtatat ggccgactgg agggccctca tcttcttccc	60
	tgc	63
20	<210> 166 <211> 64 <212> DNA <213> Artificial Sequence	
25	<220> <223> Synthetic sequence	
30	<400> 166	
	cttcaaggaa gaaattcaac agggtagggg ttgcggcgat aaggccctc atcttcttcc	60
	ctgc	64
35	<210> 167 <211> 62 <212> DNA <213> Artificial Sequence	
40	<220> <223> Synthetic sequence	
45	<400> 167	
	catggattca acacagcaaa caccaagtca accacccgag acgccctcat cttcttcct	60
	gc	62
50	<210> 168 <211> 62 <212> DNA <213> Artificial Sequence	
55	<220> <223> Synthetic sequence	

EP 3 036 545 B1

<400> 168

5 ctctgacctc cttcactctt acacttcctt ggccttcctt ctgccctcat cttcttcctt 60  
gc 62

<210> 169

<211> 62

10 <212> DNA

<213> Artificial Sequence

<220>

<223> Synthetic sequence

15

<400> 169

20 gctttcattt gtgctaaacc tcgcttgggt cctctcctga acgccctcat cttcttcctt 60  
gc 62

<210> 170

<211> 58

25 <212> DNA

<213> Artificial Sequence

<220>

<223> Synthetic sequence

30

<400> 170

catccagat gccctcataa cgtccgaacc acaatgctgc cctcatctt ttccctgc 58

<210> 171

<211> 62

35 <212> DNA

<213> Artificial Sequence

<220>

<223> Synthetic sequence

40

<400> 171

45 gtagaaatcc caaggcaatc agctcctcgc atccaacagt cggccctcat cttcttcctt 60  
gc 62

<210> 172

<211> 63

50 <212> DNA

<213> Artificial Sequence

<220>

<223> Synthetic sequence

55

<400> 172

EP 3 036 545 B1

gaacaactaa ctccacagaa cccccaccgt agcactcctt cttgccctca tcttcttccc 60  
tgc 63

5  
<210> 173  
<211> 59  
<212> DNA  
<213> Artificial Sequence

10  
<220>  
<223> Synthetic sequence

<400> 173  
15 gtgcagagga caggaagaac ggagcgtcgg tagtgtaaag ccctcatctt cttccctgc 59

<210> 174  
<211> 63  
<212> DNA  
20 <213> Artificial Sequence

<220>  
<223> Synthetic sequence

25 <400> 174

ggtgcttcaa gacatacacc ttaacaactc gacgaaccta cgggccctca tcttcttccc 60

30  
tgc 63

<210> 175  
<211> 60  
35 <212> DNA  
<213> Artificial Sequence

<220>  
<223> Synthetic sequence

40  
<400> 175  
ggaacctctg tgacctgga tggcccatcc ttatgtgctg gcctcatct tcttccctgc 60

<210> 176  
45 <211> 59  
<212> DNA  
<213> Artificial Sequence

<220>  
50 <223> Synthetic sequence

<400> 176  
cccagtgga ccttctgaag gtcgtattg ctcaagcccg ccctcatctt cttccctgc 59

55  
<210> 177  
<211> 63  
<212> DNA  
<213> Artificial Sequence

EP 3 036 545 B1

<220>  
<223> Synthetic sequence

<400> 177

5

cttctgttgc ttatttgggt aacttgattc tggcctccc atcgccctca tcttcttccc 60  
tgc 63

10

<210> 178  
<211> 56  
<212> DNA  
<213> Artificial Sequence

15

<220>  
<223> Synthetic sequence

<400> 178

20 cccactggat gcctccctca cgccgctat ttagtgccc tcatcttct cctgc 56

<210> 179  
<211> 58  
<212> DNA  
<213> Artificial Sequence

25

<220>  
<223> Synthetic sequence

<400> 179

30 cggagagacg catctgaaag tctgggtagg tggaggacgc cctcatctc ttcctgc 58

<210> 180  
<211> 61  
<212> DNA  
<213> Artificial Sequence

35

<220>  
<223> Synthetic sequence

40

<400> 180

caggatttcc agcttacagg gcgactgagc cacatccaac tgcctcatc ttcttcctg 60  
c 61

45

<210> 181  
<211> 60  
<212> DNA  
<213> Artificial Sequence

50

<220>  
<223> Synthetic sequence

<400> 181

55 cttgcaagat gtgcctcta gagcctcagc cggaattgaa gcctcatct tcttcctgc 60

<210> 182

EP 3 036 545 B1

<211> 62  
 <212> DNA  
 <213> Artificial Sequence

5

<220>  
 <223> Synthetic sequence

<400> 182

10

ggggtggtttc tctaaacaca aattgccatt ctgcaccaat gcgccctcat cttcttcct 60  
 gc 62

15

<210> 183  
 <211> 62  
 <212> DNA  
 <213> Artificial Sequence

20

<220>  
 <223> Synthetic sequence

<400> 183

25

gcagggtatt gagagaagga tctattggtg ttcgcggtg atgccctcat cttcttcct 60  
 gc 62

30

<210> 184  
 <211> 62  
 <212> DNA  
 <213> Artificial Sequence

35

<220>  
 <223> Synthetic sequence

<400> 184

40

gtgcacattt cttgatgaag ggatgggctg aacaggagga ctgccctcat cttcttcct 60  
 gc 62

45

<210> 185  
 <211> 62  
 <212> DNA  
 <213> Artificial Sequence

50

<220>  
 <223> Synthetic sequence

<400> 185

55

gagcaatgcc tgtttcatga gaggaatggc ctacctgcat cagccctcat cttcttcct 60  
 gc 62

EP 3 036 545 B1

<210> 186  
<211> 64  
<212> DNA  
<213> Artificial Sequence  
5  
<220>  
<223> Synthetic sequence  
10  
<400> 186  
gttaacatta tacagcatgg tggccccgtt gttgtcatcg catcgccctc atcttcttcc 60  
ctgc 64  
15  
<210> 187  
<211> 59  
<212> DNA  
<213> Artificial Sequence  
20  
<220>  
<223> Synthetic sequence  
<400> 187  
25 gcagaacatg tctgaagcg ttcgatgctg cccatgagtg ccctcatctt tttccctgc 59  
<210> 188  
<211> 60  
<212> DNA  
30 <213> Artificial Sequence  
<220>  
<223> Synthetic sequence  
35 <400> 188  
cagcttgctc ccaaaccat caaccgcgt agatgttctt gccctcatct tcttccctgc 60  
<210> 189  
<211> 61  
40 <212> DNA  
<213> Artificial Sequence  
<220>  
<223> Synthetic sequence  
45 <400> 189  
caaagtgtgg aagttgcttc cgccagctca agagtgtagc cgccctcatc ttcttccctg 60  
50 c 61  
<210> 190  
<211> 58  
<212> DNA  
55 <213> Artificial Sequence  
<220>  
<223> Synthetic sequence

EP 3 036 545 B1

<400> 190  
 ggtcgacttt gtccatcctt ctgacccctg cgcgatgtgc cctcatcttc ttcctgc 58  
  
 5 <210> 191  
 <211> 59  
 <212> DNA  
 <213> Artificial Sequence  
  
 <220>  
 10 <223> Synthetic sequence  
  
 <400> 191  
 ctctgttgc tgggactca tcgaggcgt tcctatagc ccctcatctt cttccctgc 59  
  
 15 <210> 192  
 <211> 64  
 <212> DNA  
 <213> Artificial Sequence  
  
 20 <220>  
 <223> Synthetic sequence  
  
 <400> 192  
  
 25 **ctaactagaa ttagtctgcc tgcctattgg acctccgacc acgagccctc atcttcttcc 60**  
  
**ctgc 64**  
  
 30 <210> 193  
 <211> 59  
 <212> DNA  
 <213> Artificial Sequence  
  
 35 <220>  
 <223> Synthetic sequence  
  
 <400> 193  
 gtgagccata atcgtgcaa gccaccattt agatccgagg ccctcatctt cttccctgc 59  
  
 40 <210> 194  
 <211> 63  
 <212> DNA  
 <213> Artificial Sequence  
  
 45 <220>  
 <223> Synthetic sequence  
  
 <400> 194  
  
 50 **gagaattaat gtcacctctc ctggaccagt agaagtctgc ccggccctca tcttcttccc 60**  
  
**tgc 63**  
  
 55 <210> 195  
 <211> 59  
 <212> DNA

EP 3 036 545 B1

<213> Artificial Sequence

<220>  
<223> Synthetic sequence

5

<400> 195  
gtggctgct gttaccaat ttcagaatgg ccgagctgtg ccctcatctt cttccctgc 59

<210> 196  
<211> 60  
<212> DNA  
<213> Artificial Sequence

10

<220>  
<223> Synthetic sequence

15

<400> 196  
ggttgcaact gctgatctat aggtgacctt cttgtacgcc gccctcatct tcttcctgc 60

20

<210> 197  
<211> 58  
<212> DNA  
<213> Artificial Sequence

25

<220>  
<223> Synthetic sequence

<400> 197  
ctttcccagt caaggcaggg cgcgtcctta ttccatcgc cctcatcttc ttcctgc 58

30

<210> 198  
<211> 20  
<212> DNA  
<213> Artificial Sequence

35

<220>  
<223> Synthetic sequence

<400> 198  
agaccagcac aacttactcg 20

40

<210> 199  
<211> 17  
<212> DNA  
<213> Artificial Sequence

45

<220>  
<223> Synthetic sequence

<400> 199  
ccaaatgcac ctgcctg 17

50

<210> 200  
<211> 21  
<212> DNA  
<213> Artificial Sequence

55

<220>

<223> Synthetic sequence  
  
 <400> 200  
 agtttgaca aaggcaattc g      21  
 5  
  
 <210> 201  
 <211> 24  
 <212> DNA  
 <213> Artificial Sequence  
 10  
  
 <220>  
 <223> Synthetic sequence  
  
 <400> 201  
 tgagcttagc caatatcaag aagg      24  
 15  
  
 <210> 202  
 <211> 22  
 <212> DNA  
 <213> Artificial Sequence  
 20  
  
 <220>  
 <223> Synthetic sequence  
  
 <400> 202  
 acgtgaactt tccttggtac ac      22  
 25  
  
 <210> 203  
 <211> 24  
 <212> DNA  
 <213> Artificial Sequence  
 30  
  
 <220>  
 <223> Synthetic sequence  
 35  
  
 <400> 203  
 tgaagatggt ctaatacctt gccg      24  
  
 <210> 204  
 <211> 18  
 <212> DNA  
 <213> Artificial Sequence  
 40  
  
 <220>  
 <223> Synthetic sequence  
 45  
  
 <400> 204  
 cagtgaggag actgaacg      18  
  
 <210> 205  
 <211> 23  
 <212> DNA  
 <213> Artificial Sequence  
 50  
  
 <220>  
 <223> Synthetic sequence  
 55  
  
 <400> 205

EP 3 036 545 B1

aggcagggta atgtcatgaa atg 23

<210> 206  
<211> 17  
5 <212> DNA  
<213> Artificial Sequence

<220>  
10 <223> Synthetic sequence

<400> 206  
gattgtctgg agcgctg 17

<210> 207  
15 <211> 16  
<212> DNA  
<213> Artificial Sequence

<220>  
20 <223> Synthetic sequence

<400> 207  
agggagcaat aggccg 16

25 <210> 208  
<211> 17  
<212> DNA  
<213> Artificial Sequence

30 <220>  
<223> Synthetic sequence

<400> 208  
35 ctgcagggta caacacg 17

<210> 209  
<211> 18  
<212> DNA  
40 <213> Artificial Sequence

<220>  
<223> Synthetic sequence

<400> 209  
45 cgtatctggg aagacggc 18

<210> 210  
<211> 20  
<212> DNA  
50 <213> Artificial Sequence

<220>  
<223> Synthetic sequence

55 <400> 210  
cctgtaatcc ctgcaatgc 20

<210> 211

<211> 18  
 <212> DNA  
 <213> Artificial Sequence  
 5 <220>  
 <223> Synthetic sequence  
 <400> 211  
 10 ggtctcagca cggttctg 18  
 <210> 212  
 <211> 17  
 <212> DNA  
 <213> Artificial Sequence  
 15 <220>  
 <223> Synthetic sequence  
 <400> 212  
 20 gcacctccct accacac 17  
 <210> 213  
 <211> 21  
 <212> DNA  
 25 <213> Artificial Sequence  
 <220>  
 <223> Synthetic sequence  
 30 <400> 213  
 gcctctagct agagagaagt c 21  
 <210> 214  
 <211> 19  
 35 <212> DNA  
 <213> Artificial Sequence  
 <220>  
 <223> Synthetic sequence  
 40 <400> 214  
 ctggcagtct agccgttac 19  
 <210> 215  
 45 <211> 23  
 <212> DNA  
 <213> Artificial Sequence  
 <220>  
 50 <223> Synthetic sequence  
 <400> 215  
 tgtcttagaa ttggcaact ggc 23  
 55 <210> 216  
 <211> 19  
 <212> DNA  
 <213> Artificial Sequence

<220>  
 <223> Synthetic sequence  
  
 <400> 216  
 5 gcaggaaagc ctactgaac 19  
  
 <210> 217  
 <211> 19  
 <212> DNA  
 10 <213> Artificial Sequence  
  
 <220>  
 <223> Synthetic sequence  
  
 <400> 217  
 15 gggagccaga gaaatgtcc 19  
  
 <210> 218  
 <211> 24  
 20 <212> DNA  
 <213> Artificial Sequence  
  
 <220>  
 <223> Synthetic sequence  
 25  
 <400> 218  
 tgtctccagt tccactcat ttag 24  
  
 <210> 219  
 <211> 19  
 <212> DNA  
 <213> Artificial Sequence  
 30  
  
 <220>  
 <223> Synthetic sequence  
 35  
  
 <400> 219  
 cccgtaatt gcctactcg 19  
 40  
 <210> 220  
 <211> 18  
 <212> DNA  
 <213> Artificial Sequence  
  
 <220>  
 <223> Synthetic sequence  
 45  
  
 <400> 220  
 50 ctcgtccca ctggaag 18  
  
 <210> 221  
 <211> 21  
 <212> DNA  
 <213> Artificial Sequence  
 55  
  
 <220>  
 <223> Synthetic sequence

EP 3 036 545 B1

<400> 221  
acacccatga ttcagttact g 21

5  
<210> 222  
<211> 21  
<212> DNA  
<213> Artificial Sequence

10  
<220>  
<223> Synthetic sequence

<400> 222  
gctagtatga acatcacagg c 21

15  
<210> 223  
<211> 23  
<212> DNA  
<213> Artificial Sequence

20  
<220>  
<223> Synthetic sequence

<400> 223  
acaaatgagt aagaagcgag tcg 23

25  
<210> 224  
<211> 18  
<212> DNA  
<213> Artificial Sequence

30  
<220>  
<223> Synthetic sequence

<400> 224  
gataagggtt gctctgcg 18

35  
<210> 225  
<211> 17  
<212> DNA  
<213> Artificial Sequence

40  
<220>  
<223> Synthetic sequence

45  
<400> 225  
ccatgacca gctacc 17

<210> 226  
<211> 20  
<212> DNA  
<213> Artificial Sequence

50  
<220>  
<223> Synthetic sequence

55  
<400> 226  
aactgtacc tactcccagc 20

<210> 227  
 <211> 21  
 <212> DNA  
 <213> Artificial Sequence  
 5  
 <220>  
 <223> Synthetic sequence  
 <400> 227  
 10 aggaccaagg gaccagtta g 21  
 <210> 228  
 <211> 22  
 <212> DNA  
 15 <213> Artificial Sequence  
 <220>  
 <223> Synthetic sequence  
 20 <400> 228  
 agagttcctc caagaaattg cg 22  
 <210> 229  
 <211> 24  
 25 <212> DNA  
 <213> Artificial Sequence  
 <220>  
 <223> Synthetic sequence  
 30 <400> 229  
 acattataca gcatgctggc tatc 24  
 <210> 230  
 <211> 21  
 35 <212> DNA  
 <213> Artificial Sequence  
 <220>  
 <223> Synthetic sequence  
 40 <400> 230  
 gaggaagaaa gtgaggttg c 21  
 <210> 231  
 <211> 24  
 <212> DNA  
 <213> Artificial Sequence  
 45 <220>  
 <223> Synthetic sequence  
 <400> 231  
 50 ctgaattatg tgcttaccaa gage 24  
 <210> 232  
 <211> 24  
 <212> DNA  
 55

<213> Artificial Sequence  
 <220>  
 <223> Synthetic sequence  
 5  
 <400> 232  
 tgggttctga taacctatc aagc 24  
 <210> 233  
 10 <211> 19  
 <212> DNA  
 <213> Artificial Sequence  
 <220>  
 15 <223> Synthetic sequence  
 <400> 233  
 ggtagtcaa acatgctgc 19  
 20 <210> 234  
 <211> 22  
 <212> DNA  
 <213> Artificial Sequence  
 25 <220>  
 <223> Synthetic sequence  
 <400> 234  
 30 gacactggca gaatcaaac ac 22  
 <210> 235  
 <211> 24  
 <212> DNA  
 <213> Artificial Sequence  
 35 <220>  
 <223> Synthetic sequence  
 <400> 235  
 40 agagttacac cttagctaa ccac 24  
 <210> 236  
 <211> 18  
 <212> DNA  
 45 <213> Artificial Sequence  
 <220>  
 <223> Synthetic sequence  
 50 <400> 236  
 ccaggagttc aagaagcg 18  
 <210> 237  
 55 <211> 21  
 <212> DNA  
 <213> Artificial Sequence  
 <220>

<223> Synthetic sequence  
  
 <400> 237  
 accactcctt tctccatct c      21  
 5  
  
 <210> 238  
 <211> 24  
 <212> DNA  
 <213> Artificial Sequence  
 10  
  
 <220>  
 <223> Synthetic sequence  
  
 <400> 238  
 gtcttatggg acaatggttg atag      24  
 15  
  
 <210> 239  
 <211> 18  
 <212> DNA  
 <213> Artificial Sequence  
 20  
  
 <220>  
 <223> Synthetic sequence  
  
 <400> 239  
 ctaccctcaa ccctcgtc      18  
 25  
  
 <210> 240  
 <211> 18  
 <212> DNA  
 <213> Artificial Sequence  
 30  
  
 <220>  
 <223> Synthetic sequence  
 35  
  
 <400> 240  
 ccaagactga tcatgccg      18  
  
 <210> 241  
 <211> 20  
 <212> DNA  
 <213> Artificial Sequence  
 40  
  
 <220>  
 <223> Synthetic sequence  
 45  
  
 <400> 241  
 agaccagcac aactactta      20  
  
 <210> 242  
 <211> 17  
 <212> DNA  
 <213> Artificial Sequence  
 50  
  
 <220>  
 <223> Synthetic sequence  
 55  
  
 <400> 242

ccaaattcac ctgccca 17  
  
 <210> 243  
 <211> 21  
 5 <212> DNA  
 <213> Artificial Sequence  
  
 <220>  
 <223> Synthetic sequence  
 10  
  
 <400> 243  
 agtttgaca aaggcgatt a 21  
  
 <210> 244  
 15 <211> 24  
 <212> DNA  
 <213> Artificial Sequence  
  
 <220>  
 20 <223> Synthetic sequence  
  
 <400> 244  
 tgagcttagc caatatcaac aaga 24  
  
 25 <210> 245  
 <211> 22  
 <212> DNA  
 <213> Artificial Sequence  
  
 30 <220>  
 <223> Synthetic sequence  
  
 <400> 245  
 35 acgtgaactt tccttgtaa at 22  
  
 <210> 246  
 <211> 24  
 <212> DNA  
 <213> Artificial Sequence  
 40  
  
 <220>  
 <223> Synthetic sequence  
  
 <400> 246  
 45 tgaagatgtt ctaatacctt gcta 24  
  
 <210> 247  
 <211> 18  
 <212> DNA  
 50 <213> Artificial Sequence  
  
 <220>  
 <223> Synthetic sequence  
  
 <400> 247  
 55 cagtgtggag accgaaca 18  
  
 <210> 248

<211> 23  
 <212> DNA  
 <213> Artificial Sequence

5

<220>  
 <223> Synthetic sequence

<400> 248  
 aggcaggga atgtcatgaa gtt 23

10

<210> 249  
 <211> 17  
 <212> DNA  
 <213> Artificial Sequence

15

<220>  
 <223> Synthetic sequence

<400> 249  
 gattgtctgg aggctc 17

20

<210> 250  
 <211> 16  
 <212> DNA  
 <213> Artificial Sequence

25

<220>  
 <223> Synthetic sequence

<400> 250  
 agggagcaat aggcta 16

30

<210> 251  
 <211> 17  
 <212> DNA  
 <213> Artificial Sequence

35

<220>  
 <223> Synthetic sequence

40

<400> 251  
 ctgcaggga caagaca 17

45

<210> 252  
 <211> 18  
 <212> DNA  
 <213> Artificial Sequence

<220>  
 <223> Synthetic sequence

50

<400> 252  
 cgatatctggg aagatggg 18

55

<210> 253  
 <211> 20  
 <212> DNA  
 <213> Artificial Sequence

<220>  
 <223> Synthetic sequence  
  
 <400> 253  
 5 cctgtaatcc ctgcaataa 20  
  
 <210> 254  
 <211> 18  
 <212> DNA  
 10 <213> Artificial Sequence  
  
 <220>  
 <223> Synthetic sequence  
  
 15 <400> 254  
 ggtctcagca cggtcctt 18  
  
 <210> 255  
 <211> 17  
 20 <212> DNA  
 <213> Artificial Sequence  
  
 <220>  
 <223> Synthetic sequence  
 25  
 <400> 255  
 gcacctcct atcacat 17  
  
 <210> 256  
 30 <211> 21  
 <212> DNA  
 <213> Artificial Sequence  
  
 <220>  
 35 <223> Synthetic sequence  
  
 <400> 256  
 gcctctagct agagagaagc g 21  
  
 40 <210> 257  
 <211> 19  
 <212> DNA  
 <213> Artificial Sequence  
  
 45 <220>  
 <223> Synthetic sequence  
  
 <400> 257  
 50 ctggcagtct agccattat 19  
  
 <210> 258  
 <211> 23  
 <212> DNA  
 <213> Artificial Sequence  
 55  
 <220>  
 <223> Synthetic sequence

EP 3 036 545 B1

<400> 258  
tgtcttagaa ttggcaact agt 23

5  
<210> 259  
<211> 19  
<212> DNA  
<213> Artificial Sequence

10  
<220>  
<223> Synthetic sequence

<400> 259  
gcaggaaagc ctattgaat 19

15  
<210> 260  
<211> 19  
<212> DNA  
<213> Artificial Sequence

20  
<220>  
<223> Synthetic sequence

<400> 260  
gggagccaga gaaattct 19

25  
<210> 261  
<211> 24  
<212> DNA  
<213> Artificial Sequence

30  
<220>  
<223> Synthetic sequence

<400> 261  
tgtctccagt tccactcat gtaa 24

35  
<210> 262  
<211> 19  
<212> DNA  
<213> Artificial Sequence

40  
<220>  
<223> Synthetic sequence

45  
<400> 262  
cccgtaatt gcctatta 19

<210> 263  
<211> 18  
<212> DNA  
<213> Artificial Sequence

50  
<220>  
<223> Synthetic sequence

55  
<400> 263  
ctcgggccca ctgggaaa 18

<210> 264  
 <211> 21  
 <212> DNA  
 <213> Artificial Sequence  
 5  
 <220>  
 <223> Synthetic sequence  
 <400> 264  
 10 acaccatga ttcagttacc a 21  
 <210> 265  
 <211> 21  
 <212> DNA  
 15 <213> Artificial Sequence  
 <220>  
 <223> Synthetic sequence  
 20 <400> 265  
 gctagtatga acatcacaag t 21  
 <210> 266  
 <211> 23  
 25 <212> DNA  
 <213> Artificial Sequence  
 <220>  
 <223> Synthetic sequence  
 30 <400> 266  
 acaaatgagt aagaagcgag tta 23  
 <210> 267  
 <211> 18  
 35 <212> DNA  
 <213> Artificial Sequence  
 <220>  
 <223> Synthetic sequence  
 40 <400> 267  
 gataagggtt gctctaca 18  
 <210> 268  
 <211> 17  
 45 <212> DNA  
 <213> Artificial Sequence  
 <220>  
 <223> Synthetic sequence  
 50 <400> 268  
 ccatgcacca gctacta 17  
 55 <210> 269  
 <211> 20  
 <212> DNA

<213> Artificial Sequence  
 <220>  
 <223> Synthetic sequence  
 5  
 <400> 269  
 aactgtaccc tactccaat 20  
 <210> 270  
 10 <211> 21  
 <212> DNA  
 <213> Artificial Sequence  
 <220>  
 15 <223> Synthetic sequence  
 <400> 270  
 aggaccaagg gaccagtca c 21  
 20 <210> 271  
 <211> 22  
 <212> DNA  
 <213> Artificial Sequence  
 25 <220>  
 <223> Synthetic sequence  
 <400> 271  
 30 agagttcctc caagaaattg ta 22  
 <210> 272  
 <211> 24  
 <212> DNA  
 <213> Artificial Sequence  
 35 <220>  
 <223> Synthetic sequence  
 <400> 272  
 40 acattataca gcatgctggt taga 24  
 <210> 273  
 <211> 21  
 <212> DNA  
 45 <213> Artificial Sequence  
 <220>  
 <223> Synthetic sequence  
 50 <400> 273  
 gaggaagaaa gtgagattg t 21  
 <210> 274  
 <211> 24  
 55 <212> DNA  
 <213> Artificial Sequence  
 <220>

<223> Synthetic sequence  
  
 <400> 274  
 ctgaattatg tgcttaccag gagt      24  
 5  
  
 <210> 275  
 <211> 24  
 <212> DNA  
 <213> Artificial Sequence  
 10  
  
 <220>  
 <223> Synthetic sequence  
  
 <400> 275  
 tgggttctga taacctatc aact      24  
 15  
  
 <210> 276  
 <211> 19  
 <212> DNA  
 <213> Artificial Sequence  
 20  
  
 <220>  
 <223> Synthetic sequence  
  
 <400> 276  
 ggtagtcaa acatgttg      19  
 25  
  
 <210> 277  
 <211> 22  
 <212> DNA  
 <213> Artificial Sequence  
 30  
  
 <220>  
 <223> Synthetic sequence  
 35  
  
 <400> 277  
 gacactggca gaatcaaacc aa      22  
  
 <210> 278  
 <211> 24  
 <212> DNA  
 <213> Artificial Sequence  
 40  
  
 <220>  
 <223> Synthetic sequence  
 45  
  
 <400> 278  
 agagttacac cttagctaa ctag      24  
  
 <210> 279  
 <211> 18  
 <212> DNA  
 <213> Artificial Sequence  
 50  
  
 <220>  
 <223> Synthetic sequence  
 55  
  
 <400> 279

EP 3 036 545 B1

ccaggagttc aaggagca 18

<210> 280  
<211> 21  
5 <212> DNA  
<213> Artificial Sequence

<220>  
10 <223> Synthetic sequence

<400> 280  
accactcctt tctcccgtct t 21

<210> 281  
15 <211> 24  
<212> DNA  
<213> Artificial Sequence

<220>  
20 <223> Synthetic sequence

<400> 281  
gtcttatggg acaatggtcg atat 24

25 <210> 282  
<211> 18  
<212> DNA  
<213> Artificial Sequence

30 <220>  
<223> Synthetic sequence

<400> 282  
35 ctaccctcaa ccctcatt 18

<210> 283  
<211> 18  
<212> DNA  
40 <213> Artificial Sequence

<220>  
<223> Synthetic sequence

<400> 283  
45 ccaagactga tcatgcta 18

<210> 284  
<211> 21  
<212> DNA  
50 <213> Artificial Sequence

<220>  
<223> Synthetic sequence

55 <400> 284  
cacttgacaa agttctcacg c 21

<210> 285

<211> 21  
 <212> DNA  
 <213> Artificial Sequence  
 5 <220>  
 <223> Synthetic sequence  
 <400> 285  
 cattagggat taacggcttg g 21  
 10  
 <210> 286  
 <211> 23  
 <212> DNA  
 <213> Artificial Sequence  
 15 <220>  
 <223> Synthetic sequence  
 <400> 286  
 20 cacacgtaa gaagacttc tgc 23  
 <210> 287  
 <211> 22  
 <212> DNA  
 25 <213> Artificial Sequence  
 <220>  
 <223> Synthetic sequence  
 30 <400> 287  
 ctaagtgcc tccatgagaa ag 22  
 <210> 288  
 <211> 20  
 35 <212> DNA  
 <213> Artificial Sequence  
 <220>  
 <223> Synthetic sequence  
 40 <400> 288  
 gcacagatt cccactct 20  
 <210> 289  
 45 <211> 21  
 <212> DNA  
 <213> Artificial Sequence  
 <220>  
 50 <223> Synthetic sequence  
 <400> 289  
 cttacaggag gtctggcatc a 21  
 55 <210> 290  
 <211> 19  
 <212> DNA  
 <213> Artificial Sequence

<220>  
 <223> Synthetic sequence  
  
 <400> 290  
 5 ccacaatgag aaggcagag 19  
  
 <210> 291  
 <211> 20  
 <212> DNA  
 10 <213> Artificial Sequence  
  
 <220>  
 <223> Synthetic sequence  
  
 <400> 291  
 15 gctgtggcat agctacactc 20  
  
 <210> 292  
 <211> 20  
 20 <212> DNA  
 <213> Artificial Sequence  
  
 <220>  
 <223> Synthetic sequence  
 25  
 <400> 292  
 cagggtaatt tgtgggtctg 20  
  
 <210> 293  
 <211> 22  
 30 <212> DNA  
 <213> Artificial Sequence  
  
 <220>  
 <223> Synthetic sequence  
 35  
 <400> 293  
 gggctatcca gaaagataag aa 22  
  
 <210> 294  
 <211> 23  
 40 <212> DNA  
 <213> Artificial Sequence  
  
 <220>  
 <223> Synthetic sequence  
 45  
 <400> 294  
 50 cataactggt ggagtatttc act 23  
  
 <210> 295  
 <211> 24  
 <212> DNA  
 <213> Artificial Sequence  
 55  
 <220>  
 <223> Synthetic sequence

EP 3 036 545 B1

<400> 295  
 cttcaaggaa gaaattcaac aggg      24

5  
 <210> 296  
 <211> 22  
 <212> DNA  
 <213> Artificial Sequence

10  
 <220>  
 <223> Synthetic sequence

<400> 296  
 catggattca acacagcaaa ca      22

15  
 <210> 297  
 <211> 22  
 <212> DNA  
 <213> Artificial Sequence

20  
 <220>  
 <223> Synthetic sequence

<400> 297  
 ctctgacctc ctcactctt ac      22

25  
 <210> 298  
 <211> 22  
 <212> DNA  
 <213> Artificial Sequence

30  
 <220>  
 <223> Synthetic sequence

<400> 298  
 gctttcattt gtgctaaacc tc      22

35  
 <210> 299  
 <211> 18  
 <212> DNA  
 <213> Artificial Sequence

40  
 <220>  
 <223> Synthetic sequence

45  
 <400> 299  
 catcccagat gccctcat      18

<210> 300  
 <211> 22  
 <212> DNA  
 <213> Artificial Sequence

50  
 <220>  
 <223> Synthetic sequence

55  
 <400> 300  
 gtagaatcc caaggcaatc ag      22

<210> 301  
 <211> 23  
 <212> DNA  
 <213> Artificial Sequence  
 5  
 <220>  
 <223> Synthetic sequence  
 <400> 301  
 10 gaacaactaa ctccacagaa ccc 23  
 <210> 302  
 <211> 19  
 <212> DNA  
 15 <213> Artificial Sequence  
 <220>  
 <223> Synthetic sequence  
 20 <400> 302  
 gtcagagga caggaagaa 19  
 <210> 303  
 <211> 23  
 25 <212> DNA  
 <213> Artificial Sequence  
 <220>  
 <223> Synthetic sequence  
 30 <400> 303  
 ggtgctcaa gacatacacc tta 23  
 <210> 304  
 <211> 20  
 35 <212> DNA  
 <213> Artificial Sequence  
 <220>  
 40 <223> Synthetic sequence  
 <400> 304  
 ggaacctctg tgacctgga 20  
 <210> 305  
 <211> 19  
 <212> DNA  
 <213> Artificial Sequence  
 50 <220>  
 <223> Synthetic sequence  
 <400> 305  
 55 cccagtgga ccttctgaa 19  
 <210> 306  
 <211> 23  
 <212> DNA

<213> Artificial Sequence  
 <220>  
 <223> Synthetic sequence  
 5  
 <400> 306  
 cttctgtgc ttattgggt aac 23  
 <210> 307  
 <211> 16  
 <212> DNA  
 <213> Artificial Sequence  
 <220>  
 <223> Synthetic sequence  
 15  
 <400> 307  
 cccactggat gcctcc 16  
 <210> 308  
 <211> 18  
 <212> DNA  
 <213> Artificial Sequence  
 20  
 <220>  
 <223> Synthetic sequence  
 25  
 <400> 308  
 cggagagacg catctgaa 18  
 <210> 309  
 <211> 21  
 <212> DNA  
 <213> Artificial Sequence  
 30  
 <220>  
 <223> Synthetic sequence  
 35  
 <400> 309  
 caggattcc agcttacagg g 21  
 <210> 310  
 <211> 20  
 <212> DNA  
 <213> Artificial Sequence  
 40  
 <220>  
 <223> Synthetic sequence  
 45  
 <400> 310  
 cttgcaagat gtgccttta 20  
 <210> 311  
 <211> 22  
 <212> DNA  
 <213> Artificial Sequence  
 50  
 <220>

<223> Synthetic sequence  
  
 <400> 311  
 5 ggggtggttc tctaaacaca aa 22  
  
 <210> 312  
 <211> 22  
 <212> DNA  
 <213> Artificial Sequence  
 10  
  
 <220>  
 <223> Synthetic sequence  
  
 <400> 312  
 15 gcagggtatt gagagaagga tc 22  
  
 <210> 313  
 <211> 22  
 <212> DNA  
 20 <213> Artificial Sequence  
  
 <220>  
 <223> Synthetic sequence  
  
 <400> 313  
 25 gtgcacattt ctgatgaag gg 22  
  
 <210> 314  
 <211> 22  
 <212> DNA  
 30 <213> Artificial Sequence  
  
 <220>  
 <223> Synthetic sequence  
 35  
  
 <400> 314  
 gagcaatgcc tgttcatga ga 22  
  
 <210> 315  
 <211> 24  
 <212> DNA  
 40 <213> Artificial Sequence  
  
 <220>  
 <223> Synthetic sequence  
 45  
  
 <400> 315  
 gtaacatta tacagcatgg tggc 24  
  
 <210> 316  
 <211> 19  
 <212> DNA  
 <213> Artificial Sequence  
 50  
  
 <220>  
 <223> Synthetic sequence  
 55  
  
 <400> 316

EP 3 036 545 B1

gcagaacatg tctgaagc 19

<210> 317  
<211> 20  
5 <212> DNA  
<213> Artificial Sequence

<220>  
10 <223> Synthetic sequence

<400> 317  
cagctgttc ccaaaccat 20

<210> 318  
15 <211> 21  
<212> DNA  
<213> Artificial Sequence

<220>  
20 <223> Synthetic sequence

<400> 318  
caaagtggtg aagtgcttc c 21

25 <210> 319  
<211> 18  
<212> DNA  
<213> Artificial Sequence

30 <220>  
<223> Synthetic sequence

<400> 319  
35 ggtcgacttt gtccatcc 18

<210> 320  
<211> 19  
<212> DNA  
<213> Artificial Sequence

40 <220>  
<223> Synthetic sequence

<400> 320  
45 ctctgttgcc tgtggactc 19

<210> 321  
<211> 24  
<212> DNA  
50 <213> Artificial Sequence

<220>  
<223> Synthetic sequence

55 <400> 321  
ctaactagaa ttagtctgcc tgcc 24

<210> 322

<211> 19  
 <212> DNA  
 <213> Artificial Sequence  
 5 <220>  
 <223> Synthetic sequence  
 <400> 322  
 10 gtgagccata atcgtgtca 19  
 <210> 323  
 <211> 23  
 <212> DNA  
 <213> Artificial Sequence  
 15 <220>  
 <223> Synthetic sequence  
 <400> 323  
 20 gagaattaat gctccctctc ctg 23  
 <210> 324  
 <211> 19  
 <212> DNA  
 25 <213> Artificial Sequence  
 <220>  
 <223> Synthetic sequence  
 30 <400> 324  
 gtggctgct gttgaccaa 19  
 <210> 325  
 <211> 20  
 35 <212> DNA  
 <213> Artificial Sequence  
 <220>  
 <223> Synthetic sequence  
 40 <400> 325  
 ggttgcaact gctgatctat 20  
 <210> 326  
 45 <211> 18  
 <212> DNA  
 <213> Artificial Sequence  
 <220>  
 50 <223> Synthetic sequence  
 <400> 326  
 cttcccagt caaggcag 18  
 55 <210> 327  
 <211> 20  
 <212> DNA  
 <213> Artificial Sequence

<220>  
 <223> Synthetic sequence  
  
 <400> 327  
 5 gccgaagttc tccgaaggat 20  
  
 <210> 328  
 <211> 20  
 <212> DNA  
 10 <213> Artificial Sequence  
  
 <220>  
 <223> Synthetic sequence  
  
 <400> 328  
 15 gacagactga cggagcttca 20  
  
 <210> 329  
 <211> 20  
 20 <212> DNA  
 <213> Artificial Sequence  
  
 <220>  
 <223> Synthetic sequence  
 25  
 <400> 329  
 tgactctgcc gcacatgatc 20  
  
 <210> 330  
 <211> 20  
 30 <212> DNA  
 <213> Artificial Sequence  
  
 <220>  
 <223> Synthetic sequence  
 35  
 <400> 330  
 gatccgatag ccctctgcag 20  
  
 <210> 331  
 <211> 20  
 40 <212> DNA  
 <213> Artificial Sequence  
  
 <220>  
 <223> Synthetic sequence  
 45  
 <400> 331  
 50 caacaggcct gctaacacc 20  
  
 <210> 332  
 <211> 20  
 <212> DNA  
 <213> Artificial Sequence  
 55  
 <220>  
 <223> Synthetic sequence

EP 3 036 545 B1

<400> 332  
ggtaacaac cgagggactc 20

5  
<210> 333  
<211> 20  
<212> DNA  
<213> Artificial Sequence

10  
<220>  
<223> Synthetic sequence

<400> 333  
ttgtcattaa tgctggcggc 20

15  
<210> 334  
<211> 20  
<212> DNA  
<213> Artificial Sequence

20  
<220>  
<223> Synthetic sequence

<400> 334  
cggtgacggt ttgcaacttt 20

25  
<210> 335  
<211> 20  
<212> DNA  
<213> Artificial Sequence

30  
<220>  
<223> Synthetic sequence

<400> 335  
gtccgcagc taagggtctc 20

35  
<210> 336  
<211> 20  
<212> DNA  
<213> Artificial Sequence

40  
<220>  
<223> Synthetic sequence

45  
<400> 336  
tactcacaaa cgactgcgca 20

50  
<210> 337  
<211> 20  
<212> DNA  
<213> Artificial Sequence

55  
<220>  
<223> Synthetic sequence

<400> 337  
cgtatatggc cgactggagg 20

<210> 338  
 <211> 20  
 <212> DNA  
 <213> Artificial Sequence  
 5  
 <220>  
 <223> Synthetic sequence  
 <400> 338  
 10 tagggttgc ggcgataagg 20  
 <210> 339  
 <211> 20  
 <212> DNA  
 15 <213> Artificial Sequence  
 <220>  
 <223> Synthetic sequence  
 20 <400> 339  
 ccaagtcaac cacccgagac 20  
 <210> 340  
 <211> 20  
 25 <212> DNA  
 <213> Artificial Sequence  
 <220>  
 <223> Synthetic sequence  
 30 <400> 340  
 acttccctgg ccttcttct 20  
 <210> 341  
 <211> 20  
 35 <212> DNA  
 <213> Artificial Sequence  
 <220>  
 <223> Synthetic sequence  
 40 <400> 341  
 gcttgggtcc tctctgaac 20  
 <210> 342  
 <211> 20  
 <212> DNA  
 <213> Artificial Sequence  
 45 <220>  
 <223> Synthetic sequence  
 <400> 342  
 50 aacgtccgaa ccacaatgct 20  
 <210> 343  
 <211> 20  
 <212> DNA  
 55

<213> Artificial Sequence  
 <220>  
 <223> Synthetic sequence  
 5  
 <400> 343  
 ctctctgcat ccaacagtcg 20  
 <210> 344  
 10 <211> 20  
 <212> DNA  
 <213> Artificial Sequence  
 <220>  
 15 <223> Synthetic sequence  
 <400> 344  
 ccaccgtagc actccttct 20  
 20 <210> 345  
 <211> 20  
 <212> DNA  
 <213> Artificial Sequence  
 25 <220>  
 <223> Synthetic sequence  
 <400> 345  
 30 cggagcgtcg gtagtgtaaa 20  
 <210> 346  
 <211> 20  
 <212> DNA  
 <213> Artificial Sequence  
 35 <220>  
 <223> Synthetic sequence  
 <400> 346  
 40 acaactcgac gaacctaccg 20  
 <210> 347  
 <211> 20  
 <212> DNA  
 45 <213> Artificial Sequence  
 <220>  
 <223> Synthetic sequence  
 50 <400> 347  
 tggcccatcc ttatgtgctg 20  
 <210> 348  
 <211> 20  
 55 <212> DNA  
 <213> Artificial Sequence  
 <220>

<223> Synthetic sequence  
  
 <400> 348  
 ggtcgttatt gctcaagccc 20  
 5  
  
 <210> 349  
 <211> 20  
 <212> DNA  
 <213> Artificial Sequence  
 10  
  
 <220>  
 <223> Synthetic sequence  
  
 <400> 349  
 ttgattctgg ccctcccatc 20  
 15  
  
 <210> 350  
 <211> 20  
 <212> DNA  
 <213> Artificial Sequence  
 20  
  
 <220>  
 <223> Synthetic sequence  
  
 <400> 350  
 ctcacgccgg ctatttaggt 20  
 25  
  
 <210> 351  
 <211> 20  
 <212> DNA  
 <213> Artificial Sequence  
 30  
  
 <220>  
 <223> Synthetic sequence  
 35  
  
 <400> 351  
 agtctgggta ggtggaggac 20  
  
 <210> 352  
 <211> 20  
 <212> DNA  
 <213> Artificial Sequence  
 40  
  
 <220>  
 <223> Synthetic sequence  
 45  
  
 <400> 352  
 cgactgagcc acatccaact 20  
  
 <210> 353  
 <211> 20  
 <212> DNA  
 <213> Artificial Sequence  
 50  
  
 <220>  
 <223> Synthetic sequence  
 55  
  
 <400> 353

EP 3 036 545 B1

gagcctcagc cggaattgaa 20

5 <210> 354  
 <211> 20  
 <212> DNA  
 <213> Artificial Sequence

10 <220>  
 <223> Synthetic sequence

<400> 354  
 ttgccattct gcaccaatgc 20

15 <210> 355  
 <211> 20  
 <212> DNA  
 <213> Artificial Sequence

20 <220>  
 <223> Synthetic sequence

<400> 355  
 tattggtgtt cgcggtgat 20

25 <210> 356  
 <211> 20  
 <212> DNA  
 <213> Artificial Sequence

30 <220>  
 <223> Synthetic sequence

<400> 356  
 atgggcgtaa caggaggact 20

35 <210> 357  
 <211> 20  
 <212> DNA  
 <213> Artificial Sequence

40 <220>  
 <223> Synthetic sequence

45 <400> 357  
 ggaatgcct acctgcatca 20

<210> 358  
 <211> 20  
 <212> DNA  
 50 <213> Artificial Sequence

<220>  
 <223> Synthetic sequence

55 <400> 358  
 cccgtgttg tcatcgcac 20

<210> 359

<211> 20  
 <212> DNA  
 <213> Artificial Sequence  
 5 <220>  
 <223> Synthetic sequence  
 <400> 359  
 gttcogatgcg tcccatgagt 20  
 10 <210> 360  
 <211> 20  
 <212> DNA  
 <213> Artificial Sequence  
 15 <220>  
 <223> Synthetic sequence  
 <400> 360  
 20 caaccgcggt agatgttct 20  
 <210> 361  
 <211> 20  
 <212> DNA  
 25 <213> Artificial Sequence  
 <220>  
 <223> Synthetic sequence  
 30 <400> 361  
 gccagctcaa gagtgtagcc 20  
 <210> 362  
 <211> 20  
 35 <212> DNA  
 <213> Artificial Sequence  
 <220>  
 <223> Synthetic sequence  
 40 <400> 362  
 ttctgatcc tgcgcatgt 20  
 <210> 363  
 <211> 20  
 45 <212> DNA  
 <213> Artificial Sequence  
 <220>  
 50 <223> Synthetic sequence  
 <400> 363  
 atcgaggcg ttcctatac 20  
 55 <210> 364  
 <211> 20  
 <212> DNA  
 <213> Artificial Sequence

EP 3 036 545 B1

<220>  
<223> Synthetic sequence

5 <400> 364  
tattggacct cggaccacga 20

<210> 365  
<211> 20  
<212> DNA  
10 <213> Artificial Sequence

<220>  
<223> Synthetic sequence

15 <400> 365  
agccaccatt tagatccgcg 20

<210> 366  
<211> 20  
20 <212> DNA  
<213> Artificial Sequence

<220>  
<223> Synthetic sequence

25 <400> 366  
gaccagtaga agtctgcccg 20

<210> 367  
<211> 20  
30 <212> DNA  
<213> Artificial Sequence

<220>  
<223> Synthetic sequence

35 <400> 367  
tttcagaatg gccgagctgt 20

40 <210> 368  
<211> 20  
<212> DNA  
<213> Artificial Sequence

45 <220>  
<223> Synthetic sequence

<400> 368  
50 aggtgacctt cttgtacgcc 20

<210> 369  
<211> 20  
<212> DNA  
55 <213> Artificial Sequence

<220>  
<223> Synthetic sequence

<400> 369  
 ggcgctcct tattccatc 20

## 5 Claims

1. A method of detecting a genetic variation in a genetic sample from a subject, comprising contacting first and second probe sets to the genetic sample, wherein the first probe set comprises a first labeling probe and a first tagging probe, and the second probe set comprises a second labeling probe and a second tagging probe,  
 10 hybridizing at least parts of the first and second probe sets to first and second nucleic acid regions of interest in nucleotide molecules of the genetic sample, respectively,  
 ligating the first probe set at least by ligating the first labeling probe and the first tagging probe,  
 ligating the second probe set at least by ligating the second labeling probe and the second tagging probe,  
 15 optionally amplifying the ligated probe sets,  
 immobilizing the tagging probes and/or the amplified tagging probes thereof to a pre-determined location on a substrate, wherein
- the first and second labeling probes and/or the amplified labeling probes thereof ligated to the immobilized  
 20 tagging probes and/or the amplified tagging probes thereof comprise first and second labels, respectively,  
 the first and second labels are different,  
 the immobilized labels are optically resolvable,  
 the immobilized first and second tagging probes and/or the amplified tagging probes thereof comprise first and  
 25 second tags, respectively, and  
 the immobilizing step is performed by immobilizing the tags to the predetermined location,
- counting (i) a first number of the first label immobilized to the substrate, and (ii) a second number of the second  
 label immobilized to the substrate, and  
 30 comparing the first and second numbers to determine the genetic variation in the genetic sample.
2. The method according to claim 1, further comprising labeling the first and second labeling probes with the first and  
 second labels, respectively, prior to the contacting step; and/or comprising tagging the first and second tagging  
 probes with first and second tags, respectively, prior to the contacting step.
3. The method according to any of claims 1-2, wherein the method comprises amplifying the ligated probe sets with  
 35 or without labeling the probes during the amplification.
4. The method according to claim 1, wherein  
 40 each of the first and second labeling probes comprises a forward or reverse priming sequence, and each of the first  
 and second tagging probes comprises a corresponding reverse or forward priming sequence and a tagging nucleotide  
 sequence as a tag,  
 the method comprises amplifying the ligated probe sets,  
 the amplifying step comprises amplifying (i) the ligated first labeling and tagging probes with first forward and reverse  
 primers hybridizing to the forward and reverse priming sequences, respectively, wherein the first forward or reverse  
 45 primer hybridizing to the first labeling probe comprises the first label, and (ii) the ligated second labeling and tagging  
 probes with second forward and reverse primers hybridizing to the forward and reverse priming sequences, respec-  
 tively, wherein the second forward or reverse primer hybridizing to the second labeling probe comprises the second  
 label,  
 the amplified tagging nucleotide sequences of the tagging probes are immobilized to a pre-determined location on  
 50 a substrate, wherein the amplified tagging nucleotide sequences of the first and second tagging probes are the first  
 and second tags,  
 the first number is the number of the first label in the amplified first probe set immobilized to the substrate, and the  
 second number is the number of the second label in the amplified second probe set immobilized to the substrate.
5. The method according to any of claims 1-4, wherein the amplifying step comprises contacting an exonuclease to  
 55 the amplified probe, digesting the 5'-end of the amplified probe set that does not have any label at the 5'-end, wherein  
 the 5'-end of the amplified probe set comprising the label at the 5'-end is protected from exonuclease digestion.

6. The method according to any of claims 1-5, wherein the determined genetic variation indicates presence or absence of cancer, pharmacokinetic variability, drug toxicity, transplant rejection, or aneuploidy in the subject.
- 5 7. The method according to any of claims 1-5, wherein the subject is a pregnant subject, and the genetic variation is a genetic variation in the fetus of the pregnant subject.
8. The method according to any of claims 1-5, wherein the subject is a pregnant subject, and the genetic variation is selected from the group consisting of trisomy 13, trisomy 18, trisomy 21, aneuploidy of X, and aneuploidy of Y in the fetus of the pregnant subject.
- 10 9. The method according to any of claims 1-8, wherein the genetic sample is selected from the group consisting of whole blood, serum, plasma, urine, saliva, sweat, fecal matter, and tears.
10. The method according to any of claims 1-9, wherein
- 15 the first labeling probe and the first tagging probe are hybridized to the first nucleic acid region of interest, and the second labeling probe and the second tagging probes are hybridized to the second nucleic acid region of interest.
11. The method according to any of claims 1-10, wherein the counting step comprises spatial filtering; or the counting step comprises watershed analysis.
- 20 12. The method according to any of claims 1-11, wherein the comparing step comprises obtaining an estimate of a relative number of the nucleotide molecules having the first and second nucleic acid regions of interest.
13. The method according to any of claims 1-12, wherein the immobilized labels of the same type are separated by a distance of at least 250 nm in both dimensions.
- 25 14. The method according to any of claims 1-13, wherein the labels are fluorescent dyes.
15. The method according to any of claims 1-14, wherein the substrate comprises a binding partner that contacts and immobilizes the tags.
- 30 16. The method according to any of claims 1-15, wherein the immobilizing step comprises hybridizing at least a part of the tag or tagging nucleotide sequence to a corresponding nucleotide molecule immobilized on the substrate.
- 35 17. The method according to any of claims 1-16, wherein the tagging probes are immobilized to an array of multiple pre-determined locations on a substrate.
18. The method according to any of claims 1-17, wherein the subject is a pregnant subject, the genetic variation is a genetic variation in the fetus of the pregnant subject, and the method further comprises
- 40 contacting maternal and paternal probe sets to the genetic sample, wherein the maternal probe set comprises a maternal labeling probe and a maternal tagging probe, and the paternal probe set comprises a paternal labeling probe and a paternal tagging probe,
- 45 hybridizing at least a part of each of the maternal and paternal probe sets to a nucleic acid region of interest in nucleotide molecules of the genetic sample, the nucleic acid region of interest comprising a predetermined Single Nucleotide Polymorphism (SNP) site, wherein
- the at least a part of the maternal probe set hybridizes to a first allele At the SNP site, the at least a part of the paternal probe set hybridizes to a second allele at the SNP site, and the first and second alleles are different from each other,
- ligating the maternal and paternal probe sets at least by ligating (i) the maternal labeling and tagging probes, and
- 50 (ii) the paternal labeling and tagging probes,
- optionally amplifying the ligated probe sets,
- immobilizing the tagging probes and/or the amplified tagging probes thereof to a pre-determined location on a substrate, wherein
- 55 the maternal and paternal labeling probes and/or the amplified labeling probes thereof ligated to the immobilized tagging probes and/or the amplified tagging probes thereof comprise maternal and paternal labels, respectively, the maternal and paternal labels are different, and the immobilized labels are optically resolvable,

counting the numbers of the maternal and paternal labels, and determining whether a proportion of a fetal material in the genetic sample is sufficient to detect the genetic variation in the fetus based on the numbers of the maternal and paternal labels.

- 5 **19.** The method according to any of claims 1-18, wherein the subject is a pregnant subject, the genetic variation is a genetic variation in the fetus of the pregnant subject, and the method further comprises contacting allele A and B probe sets that are allele-specific to the genetic sample, wherein the allele A probe set comprises an allele A labeling probe and an allele A tagging probe, and the allele B probe set comprises an allele B labeling probe and an allele B tagging probe,  
10 hybridizing at least a part of each of the allele A and allele B probe sets to a nucleic acid region of interest in nucleotide molecules of the genetic sample, the nucleic acid region of interest comprising a predetermined single nucleotide polymorphism (SNP) site for which a maternal allelic profile differs from a fetal allelic profile at the SNP site, wherein the at least a part of the allele A probe set hybridizes to a first allele at the SNP site, the at least a part of the allele B probe set hybridizes to a second allele at the SNP site, and the first and second alleles are different from each other,  
15 ligating the allele A and B probe sets at least by ligating (i) the allele A labeling and tagging probes, and (ii) the allele B labeling and tagging probes, optionally amplifying the ligated probe sets, immobilizing the tagging probes and/or the amplified tagging probes thereof to a pre-determined location on a substrate, wherein

20 the allele A and allele B labeling probes and/or the amplified labeling probes thereof ligated to the immobilized tagging probes and/or the amplified tagging probes thereof comprise allele A and allele B labels, respectively, the allele A and allele B labels are different, and the immobilized labels are optically resolvable,

25 counting the numbers of the allele A and allele B labels, and determining whether a proportion of a fetal material in the genetic sample is sufficient to detect the genetic variation in the fetus based on the numbers of the allele A and allele B labels.

- 30 **20.** The method according to any of claims 1-19, wherein the method excludes sequencing of the nucleic acid region(s) of interest and/or the probes.

**21.** The method according to any of claims 1-20, wherein the method excludes bulk array readout or analog quantification.

- 35 **22.** The method according to any of claims 1-21, wherein the counting step comprises measuring optical signals from the immobilized labels, and calibrating the counted numbers by distinguishing an optical signal from a single label from the rest of the optical signals from background and/or multiple labels.

- 40 **23.** The method according to any of claims 1-22, wherein the counting step further comprises confirming the counting, wherein the confirming comprises contacting first and second control probe sets to the genetic sample, wherein the first control probe set comprises a first control labeling probe and the first tagging probe, and the second control probe set comprises a second control labeling probe and the second tagging probe,  
45 hybridizing at least a part of the first and second control probe sets to the first and second nucleic acid regions of interest in nucleotide molecules of the genetic sample, respectively, ligating the first control probe set at least by ligating the first control labeling probe and the first tagging probe, ligating the second control probe set at least by ligating the second control labeling probe and the second tagging probe,  
50 optionally amplifying the ligated probe sets, immobilizing each of the tagging probes and/or the amplified tagging probes thereof to a pre-determined location on a substrate, wherein

55 the first and second control labeling probes and/or the amplified labeling probes thereof ligated to the immobilized tagging probes and/or the amplified tagging probes thereof comprise first and second control labels, respectively, the first and second control labels are different, and the immobilized labels are optically resolvable,

measuring the optical signals from the control labels immobilized to the substrate, and comparing the optical signals from the immobilized first and second control labels to the optical signals from the immobilized first and second labels to determine whether an error based on the labels exists

- 5 **24.** The method according to claim 23, wherein the first label and the second control label are the same, and the second label and the first control label are the same.

### 10 Patentansprüche

1. Verfahren zum Erkennen einer genetischen Variation in einer genetischen Probe eines Subjekts, umfassend das Inkontaktbringen von einem ersten und zweiten Sondenset mit der genetischen Probe, wobei das erste Sondenset eine erste Markierungs-sonde und eine erste Tagging-Sonde umfasst, und das zweite Sondenset eine zweite Markierungs-sonde und eine zweite Tagging-Sonde umfasst,  
 15 Hybridisieren von zumindest Teilen des ersten und zweiten Sondensets zu einer ersten bzw. zweiten Nukleinsäureregion von Interesse in Nukleotidmoleküle der genetischen Probe,  
 Ligieren des ersten Sondensets zumindest durch Ligieren der ersten Markierungs-sonde und der ersten Tagging-Sonde,  
 20 Ligieren des zweiten Sondensets zumindest durch Ligieren der zweiten Markierungs-sonde und der zweiten Tagging-Sonde,  
 gegebenenfalls Amplifizieren der ligierten Sondensets,  
 Immobilisieren der Tagging-Sonden und/oder der amplifizierten Tagging-Sonden davon an einer vorbestimmten Position auf einem Substrat, wobei  
 die erste und zweite Markierungs-sonde und/oder die amplifizierten Markierungs-sonden davon an die immobilisierten  
 25 Tagging-Sonden ligiert sind und/oder die amplifizierten Tagging-Sonden davon erste bzw. zweite Markierungen umfassen,  
 wobei die erste und die zweite Markierung unterschiedlich sind,  
 die immobilisierten Markierungen optisch lösbar sind,  
 die immobilisierten ersten und zweiten Tagging-Sonden und/oder die amplifizierten Tagging-Sonden davon erste  
 30 bzw. zweite Tags umfassen, und  
 der Schritt des Immobilisierens durch das Immobilisieren der Tags an der vorbestimmten Position durchgeführt wird, das Zählen (i) einer ersten Anzahl der ersten Markierung, die auf dem Substrat immobilisiert ist, und (ii) einer zweiten Anzahl der zweiten Markierung, die auf dem Substrat immobilisiert ist, und  
 das Vergleichen der ersten und der zweiten Anzahl, um die genetische Variation in der genetischen Probe zu  
 35 bestimmen.
2. Verfahren nach Anspruch 1, ferner umfassend das Markieren der ersten und zweiten Markierungs-sonde mit der ersten bzw. der zweiten Markierung vor dem Schritt des Inkontaktbringens; und/oder umfassend das Tagging der ersten und zweiten Tagging-Sonde mit dem ersten bzw. dem zweiten Tag vor dem Schritt des Inkontaktbringens.
- 40 3. Verfahren nach einem der Ansprüche 1-2, wobei das Verfahren das Amplifizieren der legierten Sondensets mit oder ohne das Markieren der Sonden während des Amplifizierens umfasst.
4. Verfahren nach Anspruch 1, wobei  
 45 jede der ersten und zweiten Markierungs-sonde eine vorwärts oder rückwärts primende Sequenz umfasst, und jede der ersten und zweiten Tagging-Sonde eine entsprechende rückwärts oder vorwärts primende Sequenz und eine Tagging-Nukleotidsequenz als ein Tag umfasst,  
 das Verfahren das Amplifizieren der ligierten Sondensets umfasst,  
 der Schritt des Amplifizierens das Amplifizieren (i) der ligierten ersten Markierungs- und Tagging-Sonden mit ersten Vorwärts- und Rückwärtsprimern, die an die vorwärts bzw. rückwärts primende Sequenz hybridisieren, wobei der  
 50 erste Vorwärts- oder Rückwärtsprimer, der an die erste Markierungs-sonde hybridisiert, die erste Markierung umfasst, und (ii) der ligierten zweiten Markierungs- und Tagging-Sonden mit zweiten Vorwärts- und Rückwärtsprimern umfasst, die an die vorwärts bzw. rückwärts primende Sequenz hybridisieren, wobei der zweite Vorwärts- oder Rückwärtsprimer, der an die zweite Markierungs-sonde hybridisiert, die zweite Markierung umfasst,  
 55 die amplifizierten Tagging-Nukleotidsequenzen der Tagging-Sonden an einer vorbestimmten Position auf einem Substrat immobilisiert sind, wobei die amplifizierten Tagging-Nukleotidsequenzen der ersten und zweiten Tagging-Sonde die ersten und zweiten Tags sind,  
 wobei die erste Anzahl die Anzahl der ersten Markierung in dem amplifizierten ersten Sondenset ist, das auf dem

Substrat immobilisiert ist, und die zweite Anzahl die Anzahl der zweiten Markierung in dem amplifizierten zweiten SONDENSET ist, das auf dem Substrat immobilisiert ist.

- 5 5. Verfahren nach einem der Ansprüche 1-4, wobei der Schritt des Amplifizierens das Inkontaktbringen einer Exonuklease mit der amplifizierten Sonde, das Verdauen des 5'-Endes des amplifizierten SONDENSETS, das keine Markierung am 5'-Ende aufweist, umfasst, wobei das 5'-Ende des amplifizierten SONDENSETS, das die Markierung am 5'-Ende umfasst, vor der Verdauung von Exonuklease geschützt ist.
- 10 6. Verfahren nach einem der Ansprüche 1-5, wobei die bestimmte genetische Variation das Vorhandensein oder Nichtvorhandensein von Krebs, pharmakokinetischer Variabilität, Medikamententoxizität, Abstoßung von Transplantaten oder Aneuploidie bei dem Subjekt anzeigt.
- 15 7. Verfahren nach einem der Ansprüche 1-5, wobei das Subjekt ein schwangeres Subjekt ist und die genetische Variation eine genetische Variation im Fötus des schwangeren Subjekts ist.
8. Verfahren nach einem der Ansprüche 1-5, wobei das Subjekt ein schwangeres Subjekt ist und die genetische Variation ausgewählt ist aus der Gruppe bestehend aus Trisomie 13, Trisomie 18, Trisomie 21, Aneuploidie von X und Aneuploidie von Y im Fötus des schwangeren Subjekts.
- 20 9. Verfahren nach einem der Ansprüche 1-8, wobei die genetische Probe ausgewählt ist aus der Gruppe bestehend aus Vollblut, Serum, Plasma, Urin, Speichel, Schweiß, Fäkalien und Tränen.
- 25 10. Verfahren nach einem der Ansprüche 1-9, wobei die erste Markierungssonde und die erste Tagging-Sonde mit der ersten Nukleinsäureregion von Interesse hybridisiert sind, und die zweite Markierungssonde und die zweite Tagging-Sonde mit der zweiten Nukleinsäureregion von Interesse hybridisiert sind.
- 30 11. Verfahren nach einem der Ansprüche 1-10, wobei der Zählschritt eine räumliche Filterung umfasst; oder der Zählschritt eine Wasserabscheideanalyse umfasst.
12. Verfahren nach einem der Ansprüche 1-11, wobei der Vergleichsschritt das Erhalten einer Schätzung einer relativen Anzahl von Nukleotidmolekülen, die die ersten und zweiten Nukleinsäureregionen von Interesse aufweisen, umfasst.
- 35 13. Verfahren nach einem der Ansprüche 1-12, wobei die immobilisierten Markierungen der gleichen Art durch einen Abstand von zumindest 250 nm in beiden Dimensionen getrennt sind.
14. Verfahren nach einem der Ansprüche 1-13, wobei die Markierungen Fluoreszenzfarbstoffe sind.
- 40 15. Verfahren nach einem der Ansprüche 1-14, wobei das Substrat einen Bindungspartner umfasst, der die Tags kontaktiert und immobilisiert.
- 45 16. Verfahren nach einem der Ansprüche 1-15, wobei der Immobilisierungsschritt das Hybridisieren von zumindest einem Teil des Tags oder der Tagging-Nukleotidsequenz mit einem entsprechenden Nukleotidmolekül, das auf dem Substrat immobilisiert ist, umfasst.
17. Verfahren nach einem der Ansprüche 1-16, wobei die Markierungssonden an einer Anordnung von mehreren vorbestimmten Positionen auf einem Substrat immobilisiert sind.
- 50 18. Verfahren nach einem der Ansprüche 1-17, wobei das Subjekt ein schwangeres Subjekt ist und die genetische Variation eine genetische Variation im Fötus des schwangeren Subjekts ist und das Verfahren weiter Folgendes umfasst  
Inkontaktbringen von mütterlichen und väterlichen SONDENSETS mit der genetischen Probe, wobei das mütterliche SONDENSET eine mütterliche Markierungssonde und eine mütterliche Tagging-Sonde umfasst, und das väterliche SONDENSET eine väterliche Markierungssonde und eine väterliche Tagging-Sonde umfasst,  
55 Hybridisieren von zumindest einem Teil jedes der mütterlichen und väterlichen SONDENSETS an einer Nukleinsäureregion von Interesse in Nukleotidmolekülen der genetischen Probe, wobei die Nukleinsäureregion von Interesse eine vorbestimmte Einzelnukleotidpolymorphismus (SNP)-Stelle umfasst, wobei

der zumindest eine Teil des mütterlichen Sondensets an ein erstes Allel an der SNP-Stelle hybridisiert, der zumindest eine Teil des väterlichen Sondensets an der SNP-Stelle an ein zweites Allel hybridisiert und das erste und zweite Allel voneinander unterschiedlich sind,

Ligieren der mütterlichen und väterlichen Sondensets zumindest durch Ligieren von (i) den mütterlichen Markierungs- und Tagging-Sonden und (ii) den väterlichen Markierungs- und Tagging-Sonden,

gegebenenfalls Amplifizieren der ligierten Sondensets,

Immobilisieren der Tagging-Sonden und/oder der amplifizierten Tagging-Sonden davon an einer vorbestimmten Position auf einem Substrat, wobei

die mütterlichen und väterlichen Markierungssonden und/oder die amplifizierten Markierungssonden davon an die immobilisierten Tagging-Sonden ligiert sind und/oder die amplifizierten Tagging-Sonden davon mütterliche bzw. väterliche Markierungen umfassen,

die mütterlichen und väterlichen Markierungen unterschiedlich sind und die immobilisierten Markierungen optisch lösbar sind,

Zählen der Anzahl der mütterlichen und väterlichen Markierungen, und Bestimmen, ob ein Anteil eines fötalen Materials in der genetischen Probe ausreicht, um die genetische Variation im Fötus basierend auf der Anzahl der mütterlichen und väterlichen Markierungen nachzuweisen.

- 19.** Verfahren nach einem der Ansprüche 1-18, wobei das Subjekt ein schwangeres Subjekt ist und die genetische Variation eine genetische Variation im Fötus des schwangeren Subjekts ist und das Verfahren weiter Folgendes umfasst

Inkontaktbringen von Allel-A- und -B-Sondensets, die für die genetische Probe allelspezifisch sind, wobei das Allel-A Sondenset eine Allel-A-Markierungs-sonde und eine Allel-A-Tagging-Sonde umfasst, und das Allel-B Sondenset eine Allel-B-Markierungs-sonde und eine Allel-B-Tagging-Sonde umfasst,

Hybridisieren von zumindest einem Teil jedes des Allel-A- und Allel-B-Sondensets an einer Nukleinsäureregion von Interesse in Nukleotidmolekülen der genetischen Probe, wobei die Nukleinsäureregion von Interesse eine vorbestimmte Einzelnukleotidpolymorphismus (SNP)-Stelle umfasst, für die sich ein mütterliches allelisches Profil von einem fötalen allelisches Profil an der SNP-Stelle unterscheidet, wobei

der zumindest eine Teil des Allel-A-Sondensets an ein erstes Allel an der SNP-Stelle hybridisiert, der zumindest eine Teil des Allel-B-Sondensets an der SNP-Stelle an ein zweites Allel hybridisiert und das erste und zweite Allel voneinander unterschiedlich sind,

Ligieren der Allel-A- und Allel-B-Sondensets zumindest durch Ligieren (i) der Allel-A-Markierungs- und Tagging-Sonden und (ii) den Allel-B-Markierungs- und Tagging-Sonden,

gegebenenfalls Amplifizieren der ligierten Sondensets,

Immobilisieren der Tagging-Sonden und/oder der amplifizierten Tagging-Sonden davon an einer vorbestimmten Position auf einem Substrat, wobei

die Allele-A- und Allele-B-Markierungssonden und/oder die amplifizierten Markierungssonden davon an die immobilisierten Tagging-Sonden ligiert sind und/oder die amplifizierten Tagging-Sonden davon Allele-A- bzw. Allele-B-Markierungen umfassen,

die Allele-A- und Allele-B-Markierungen unterschiedlich sind und die immobilisierten Markierungen optisch lösbar sind,

Zählen der Anzahl der Allele-A- und Allele-B-Markierungen, und

Bestimmen, ob ein Anteil eines fötalen Materials in der genetischen Probe ausreicht, um die genetische Variation im Fötus basierend auf der Anzahl der Allele-A- und Allele-B-Markierungen nachzuweisen.

- 20.** Verfahren nach einem der Ansprüche 1-19, wobei das Verfahren die Sequenzierung der Nukleinsäureregion(en) von Interesse und/oder der Sonden ausschließt.

- 21.** Verfahren nach einem der Ansprüche 1-20, wobei das Verfahren das Auslesen von Bulk-Arrays oder die analoge Quantifizierung ausschließt.

- 22.** Verfahren nach einem der Ansprüche 1-21, wobei der Zähler Schritt das Messen optischer Signale von den immobilisierten Markierungen, und das Kalibrieren der gezählten Anzahl durch Unterscheiden eines optischen Signals von einer einzelnen Markierung von den übrigen optischen Signalen von Hintergrund und/oder mehreren Markierungen umfasst.

- 23.** Verfahren nach einem der Ansprüche 1-22, wobei der Zähler Schritt weiter das Bestätigen des Zählens umfasst, wobei das Bestätigen Folgendes umfasst

Inkontaktbringen von ersten und zweiten Kontrollsondensets mit der genetischen Probe, wobei das erste Kontroll-

sondenset eine erste Kontrollmarkierungs-sonde und die erste Tagging-Sonde umfasst, und das zweite Kontroll-  
 sondenset eine zweite Kontrollmarkierungs-sonde und die zweite Tagging-Sonde umfasst,  
 Hybridisieren von zumindest einem Teil des ersten und zweiten Kontrollsondensets zu der ersten bzw. zweiten  
 Nukleinsäureregion von Interesse in Nukleotidmoleküle der genetischen Probe,  
 5 Ligieren des ersten Kontrollsondensets zumindest durch Ligieren der ersten Kontrollmarkierungs-sonde und der  
 ersten Tagging-Sonde,  
 Ligieren des zweiten Kontrollsondensets zumindest durch Ligieren der zweiten Kontrollmarkierungs-sonde und der  
 zweiten Tagging-Sonde,  
 gegebenenfalls Amplifizieren der ligierten Sonden,  
 10 Immobilisieren jede der Tagging-Sonden und/oder der amplifizierten Tagging-Sonden davon an einer vorbestimmten  
 Position auf einem Substrat, wobei  
 die ersten und zweiten Kontrollmarkierungs-sonden und/oder die amplifizierten Markierungs-sonden davon an die  
 immobilisierten Tagging-Sonden ligiert sind und/oder die amplifizierten Tagging-Sonden davon erste bzw. zweite  
 15 Kontrollmarkierungen umfassen,  
 die ersten und zweiten Kontrollmarkierungen unterschiedlich sind und die immobilisierten Markierungen optisch  
 lösbar sind,  
 Messen der optischen Signale von den auf dem Substrat immobilisierten Kontrollmarkierungen, und  
 Vergleichen der optischen Signale von den immobilisierten ersten und zweiten Kontrollmarkierungen mit den opti-  
 schen Signalen von den immobilisierten ersten und zweiten Markierungen, um zu bestimmen, ob ein Fehler basierend  
 20 auf den Markierungen vorliegt.

24. Verfahren nach Anspruch 23, wobei die erste Markierung und die zweite Kontrollmarkierung gleich sind und die  
 zweite Markierung und die erste Kontrollmarkierung gleich sind.

## Revendications

1. Procédé de détection d'une variation génétique dans un échantillon génétique d'un sujet, comprenant  
 la mise en contact de premier et second ensembles de sondes avec l'échantillon génétique, dans lequel le premier  
 30 ensemble de sondes comprend une première sonde de marquage et une première sonde d'étiquetage, et le second  
 ensemble de sondes comprend une seconde sonde de marquage et une seconde sonde d'étiquetage,  
 l'hybridation d'au moins des parties des premier et second ensembles de sondes aux premières et secondes régions  
 d'acide nucléique d'intérêt dans les molécules nucléotidiques de l'échantillon génétique, respectivement,  
 la ligature du premier ensemble de sondes au moins par ligature de la première sonde de marquage et de la première  
 35 sonde d'étiquetage,  
 la ligature du second ensemble de sondes au moins par ligature de la seconde sonde de marquage et de la seconde  
 sonde d'étiquetage,  
 facultativement l'amplification des ensembles de sondes ligaturés, l'immobilisation des sondes d'étiquetage et/ou  
 des sondes d'étiquetage amplifiées de celles-ci à un emplacement prédéterminé sur un substrat, dans lequel  
 40 les première et seconde sondes de marquage et/ou les sondes de marquage amplifiées de celles-ci ligaturées aux  
 sondes d'étiquetage immobilisées et/ou aux sondes d'étiquetage amplifiées de celles-ci comprennent des premier  
 et second marqueurs, respectivement,  
 les premier et second marqueurs sont différents,  
 les marqueurs immobilisés sont différenciables optiquement,  
 45 les première et seconde sondes d'étiquetage immobilisées et/ou les sondes d'étiquetage amplifiées de celles-ci  
 comprennent des première et seconde étiquettes, respectivement, et  
 l'étape d'immobilisation est réalisée par immobilisation des étiquettes à l'emplacement prédéterminé,  
 le comptage (i) d'un premier nombre du premier marqueur immobilisé sur le substrat, et (ii) d'un second nombre du  
 second marqueur immobilisé sur le substrat, et  
 50 la comparaison des premier et second nombres pour déterminer la variation génétique dans l'échantillon génétique.
2. Procédé selon la revendication 1, comprenant en outre le marquage des première et seconde sondes de marquage  
 avec les premier et second marqueurs, respectivement, avant l'étape de mise en contact ; et/ou comprenant l'éti-  
 quetage des première et seconde sondes d'étiquetage avec des première et seconde étiquettes, respectivement,  
 55 avant l'étape de mise en contact.
3. Procédé selon l'une quelconque des revendications 1 à 2, dans lequel le procédé comprend l'amplification des  
 ensembles de sondes ligaturés avec ou sans marquage des sondes durant l'amplification.

4. Procédé selon la revendication 1, dans lequel  
 chacune des première et seconde sondes de marquage comprend une séquence d'amorçage sens ou antisens, et  
 chacune des première et seconde sondes d'étiquetage comprend une séquence d'amorçage antisens ou sens  
 correspondante et une séquence nucléotidique d'étiquetage en tant qu'étiquette,  
 5 le procédé comprend l'amplification des ensembles de sondes ligaturés,  
 l'étape d'amplification comprend l'amplification (i) des premières sondes de marquage et d'étiquetage ligaturées  
 avec des premières amorces sens et antisens s'hybridant aux séquences d'amorçage sens et antisens, respecti-  
 vement, dans lequel la première amorce sens ou antisens s'hybridant à la première sonde de marquage comprend  
 10 le premier marqueur, et (ii) les secondes sondes de marquage et d'étiquetage ligaturées avec des secondes amorces  
 sens et antisens s'hybridant aux séquences d'amorçage sens et antisens, respectivement, dans lequel la seconde  
 amorce sens ou antisens s'hybridant à la seconde sonde de marquage comprend le second marqueur,  
 les séquences nucléotidiques d'étiquetage amplifiées des sondes d'étiquetage sont immobilisées à un emplacement  
 prédéterminé sur un substrat, dans lequel les séquences nucléotidiques d'étiquetage amplifiées des première et  
 15 seconde sondes d'étiquetage sont les première et seconde étiquettes,  
 le premier nombre est le nombre du premier marqueur dans le premier ensemble de sondes amplifié immobilisé  
 sur le substrat, et le second nombre est le nombre du second marqueur dans le second ensemble de sondes amplifié  
 immobilisé sur le substrat.
5. Procédé selon l'une quelconque des revendications 1 à 4, dans lequel l'étape d'amplification comprend la mise en  
 20 contact d'une exonucléase avec la sonde amplifiée, la digestion de l'extrémité 5' de l'ensemble de sondes amplifié  
 qui ne comporte aucun marqueur au niveau de l'extrémité 5', dans lequel l'extrémité 5' de l'ensemble de sondes  
 amplifié comprenant le marqueur au niveau de l'extrémité 5' est protégée de la digestion par l'exonucléase.
6. Procédé selon l'une quelconque des revendications 1 à 5, dans lequel la variation génétique déterminée indique la  
 25 présence ou l'absence d'un cancer, d'une variabilité pharmacocinétique, d'une toxicité médicamenteuse, d'un rejet  
 de greffe ou d'une aneuploïdie chez le sujet.
7. Procédé selon l'une quelconque des revendications 1 à 5, dans lequel le sujet est un sujet gravide, et la variation  
 30 génétique est une variation génétique chez le fœtus du sujet gravide.
8. Procédé selon l'une quelconque des revendications 1 à 5, dans lequel le sujet est un sujet gravide, et la variation  
 génétique est choisie dans le groupe constitué de la trisomie 13, de la trisomie 18, de la trisomie 21, de l'aneuploïdie  
 de X et de l'aneuploïdie de Y chez le fœtus du sujet gravide.
- 35 9. Procédé selon l'une quelconque des revendications 1 à 8, dans lequel l'échantillon génétique est choisi dans le  
 groupe constitué du sang entier, du sérum, du plasma, de l'urine, de la salive, de la sueur, des matières fécales et  
 des larmes.
- 40 10. Procédé selon l'une quelconque des revendications 1 à 9, dans lequel  
 la première sonde de marquage et la première sonde d'étiquetage sont hybridées à la première région d'acide  
 nucléique d'intérêt, et  
 la seconde sonde de marquage et les secondes sondes d'étiquetage sont hybridées à la seconde région d'acide  
 nucléique d'intérêt.
- 45 11. Procédé selon l'une quelconque des revendications 1 à 10, dans lequel l'étape de comptage comprend un filtrage  
 spatial ; ou l'étape de comptage comprend une analyse par segmentation d'image.
12. Procédé selon l'une quelconque des revendications 1 à 11, dans lequel l'étape de comparaison comprend l'obtention  
 d'une estimation d'un nombre relatif des molécules nucléotidiques comportant les première et seconde régions  
 50 d'acide nucléique d'intérêt.
13. Procédé selon l'une quelconque des revendications 1 à 12, dans lequel les marqueurs immobilisés du même type  
 sont séparés d'une distance d'au moins 250 nm dans les deux dimensions.
- 55 14. Procédé selon l'une quelconque des revendications 1 à 13, dans lequel les marqueurs sont des colorants fluores-  
 cents.
15. Procédé selon l'une quelconque des revendications 1 à 14, dans lequel le substrat comprend un partenaire de

liaison qui vient en contact avec les étiquettes et les immobilise.

- 5
16. Procédé selon l'une quelconque des revendications 1 à 15, dans lequel l'étape d'immobilisation comprend l'hybridation d'au moins une partie de l'étiquette ou de la séquence nucléotidique d'étiquetage à une molécule nucléotidique correspondante immobilisée sur le substrat.
- 10
17. Procédé selon l'une quelconque des revendications 1 à 16, dans lequel les sondes d'étiquetage sont immobilisées sur un réseau de multiples emplacements prédéterminés sur un substrat.
- 15
18. Procédé selon l'une quelconque des revendications 1 à 17, dans lequel le sujet est un sujet gravide, la variation génétique est une variation génétique chez le fœtus du sujet gravide, et le procédé comprend en outre la mise en contact d'ensembles de sondes maternelles et paternelles avec l'échantillon génétique, dans lequel l'ensemble de sondes maternelles comprend une sonde de marquage maternelle et une sonde d'étiquetage maternelle, et l'ensemble de sondes paternelles comprend une sonde de marquage paternelle et une sonde d'étiquetage paternelle,
- 20
- l'hybridation d'au moins une partie de chacun des ensembles de sondes maternelles et paternelles à une région d'acide nucléique d'intérêt dans les molécules nucléotidiques de l'échantillon génétique, la région d'acide nucléique d'intérêt comprenant un site de polymorphisme mononucléotidique (SNP) prédéterminé, dans lequel l'au moins une partie de l'ensemble de sondes maternelles s'hybride à un premier allèle au niveau du site SNP, l'au moins une partie de l'ensemble de sondes paternelles s'hybride à un second allèle au niveau du site SNP, et les premier et second allèles sont différents l'un de l'autre,
- 25
- la ligature des ensembles de sondes maternelles et paternelles au moins par ligature (i) des sondes de marquage et d'étiquetage maternelles, et (ii) des sondes de marquage et d'étiquetage paternelles, facultativement l'amplification des ensembles de sondes ligaturés, l'immobilisation des sondes d'étiquetage et/ou des sondes d'étiquetage amplifiées de celles-ci à un emplacement prédéterminé sur un substrat, dans lequel les sondes de marquage maternelles et paternelles et/ou les sondes de marquage amplifiées de celles-ci ligaturées aux sondes d'étiquetage immobilisées et/ou aux sondes d'étiquetage amplifiées de celles-ci comprennent des marqueurs maternels et paternels, respectivement,
- 30
- les marqueurs maternels et paternels sont différents, et les marqueurs immobilisés sont différenciables optiquement, le comptage des nombres des marqueurs maternels et paternels, et le fait de déterminer si une proportion d'un matériau foetal dans l'échantillon génétique est suffisante pour détecter la variation génétique chez le fœtus sur la base des nombres des marqueurs maternels et paternels.
- 35
19. Procédé selon l'une quelconque des revendications 1 à 18, dans lequel le sujet est un sujet gravide, la variation génétique est une variation génétique chez le fœtus du sujet gravide, et le procédé comprend en outre la mise en contact des ensembles de sondes des allèles A et B qui sont spécifiques à un allèle avec l'échantillon génétique, dans lequel l'ensemble de sondes de l'allèle A comprend une sonde de marquage de l'allèle A et une sonde d'étiquetage de l'allèle A, et l'ensemble de sondes de l'allèle B comprend une sonde de marquage de l'allèle B et une sonde d'étiquetage de l'allèle B,
- 40
- l'hybridation d'au moins une partie de chacun des ensembles de sondes de l'allèle A et de l'allèle B à une région d'acide nucléique d'intérêt dans les molécules nucléotidiques de l'échantillon génétique, la région d'acide nucléique d'intérêt comprenant un site de polymorphisme mononucléotidique (SNP) prédéterminé pour lequel un profil allélique maternel diffère d'un profil allélique foetal au niveau du site SNP, dans lequel l'au moins une partie de l'ensemble de sondes de l'allèle A s'hybride à un premier allèle au niveau du site SNP, l'au moins une partie de l'ensemble de sondes de l'allèle B s'hybride à un second allèle au niveau du site SNP, et les premier et second allèles sont différents l'un de l'autre,
- 45
- la ligature des ensembles de sondes des allèles A et B au moins par ligature (i) des sondes de marquage et d'étiquetage de l'allèle A, et (ii) des sondes de marquage et d'étiquetage de l'allèle B, facultativement l'amplification des ensembles de sondes ligaturés, l'immobilisation des sondes d'étiquetage et/ou des sondes d'étiquetage amplifiées de celles-ci à un emplacement prédéterminé sur un substrat, dans lequel les sondes de marquage de l'allèle A et de l'allèle B et/ou les sondes de marquage amplifiées de celles-ci ligaturées aux sondes d'étiquetage immobilisées et/ou aux sondes d'étiquetage amplifiées de celles-ci comprennent des marqueurs de l'allèle A et de l'allèle B, respectivement,
- 50
- les marqueurs de l'allèle A et de l'allèle B sont différents, et les marqueurs immobilisés sont différenciables optiquement, le comptage des nombres des marqueurs de l'allèle A et de l'allèle B, et le fait de déterminer si une proportion d'un matériau foetal dans l'échantillon génétique est suffisante pour détecter
- 55

la variation génétique chez le fœtus sur la base des nombres des marqueurs de l'allèle A et de l'allèle B.

20. Procédé selon l'une quelconque des revendications 1 à 19, dans lequel le procédé exclut le séquençage de la (des) région(s) d'acide nucléique d'intérêt et/ou des sondes.

5

21. Procédé selon l'une quelconque des revendications 1 à 20, dans lequel le procédé exclut la lecture de réseau complet ou la quantification analogique.

22. Procédé selon l'une quelconque des revendications 1 à 21, dans lequel l'étape de comptage comprend la mesure de signaux optiques provenant des marqueurs immobilisés, et l'étalonnage des nombres comptés par distinction d'un signal optique provenant d'un marqueur unique du reste des signaux optiques provenant du fond et/ou de multiples marqueurs.

10

23. Procédé selon l'une quelconque des revendications 1 à 22, dans lequel l'étape de comptage comprend en outre la confirmation du comptage, dans lequel la confirmation comprend la mise en contact de premier et second ensembles de sondes témoins avec l'échantillon génétique, dans lequel le premier ensemble de sondes témoins comprend une première sonde de marquage témoin et la première sonde d'étiquetage, et le second ensemble de sondes témoins comprend une seconde sonde de marquage témoin et la seconde sonde d'étiquetage,

15

l'hybridation d'au moins une partie des premier et second ensembles de sondes témoins aux première et seconde régions d'acide nucléique d'intérêt dans les molécules nucléotidiques de l'échantillon génétique, respectivement, la ligature du premier ensemble de sondes témoins au moins par ligature de la première sonde de marquage témoin et de la première sonde d'étiquetage,

20

la ligature du second ensemble de sondes témoins au moins par ligature de la seconde sonde de marquage témoin et de la seconde sonde d'étiquetage,

25

facultativement l'amplification des ensembles de sondes ligaturés, l'immobilisation de chacune des sondes d'étiquetage et/ou des sondes d'étiquetage amplifiées de celles-ci à un emplacement prédéterminé sur un substrat, dans lequel

les première et seconde sondes de marquage témoins et/ou les sondes de marquage amplifiées de celles-ci ligaturées aux sondes d'étiquetage immobilisées et/ou aux sondes d'étiquetage amplifiées de celles-ci comprennent des premier et second marqueurs témoins, respectivement,

30

les premier et second marqueurs témoins sont différents, et

les marqueurs immobilisés sont différenciables optiquement,

la mesure des signaux optiques provenant des marqueurs témoins immobilisés sur le substrat, et

35

la comparaison des signaux optiques provenant des premier et second marqueurs témoins immobilisés aux signaux optiques provenant des premier et second marqueurs immobilisés pour déterminer si une erreur basée sur les marqueurs existe.

24. Procédé selon la revendication 23, dans lequel le premier marqueur et le second marqueur témoin sont identiques, et le second marqueur et le premier marqueur témoin sont identiques.

40

45

50

55

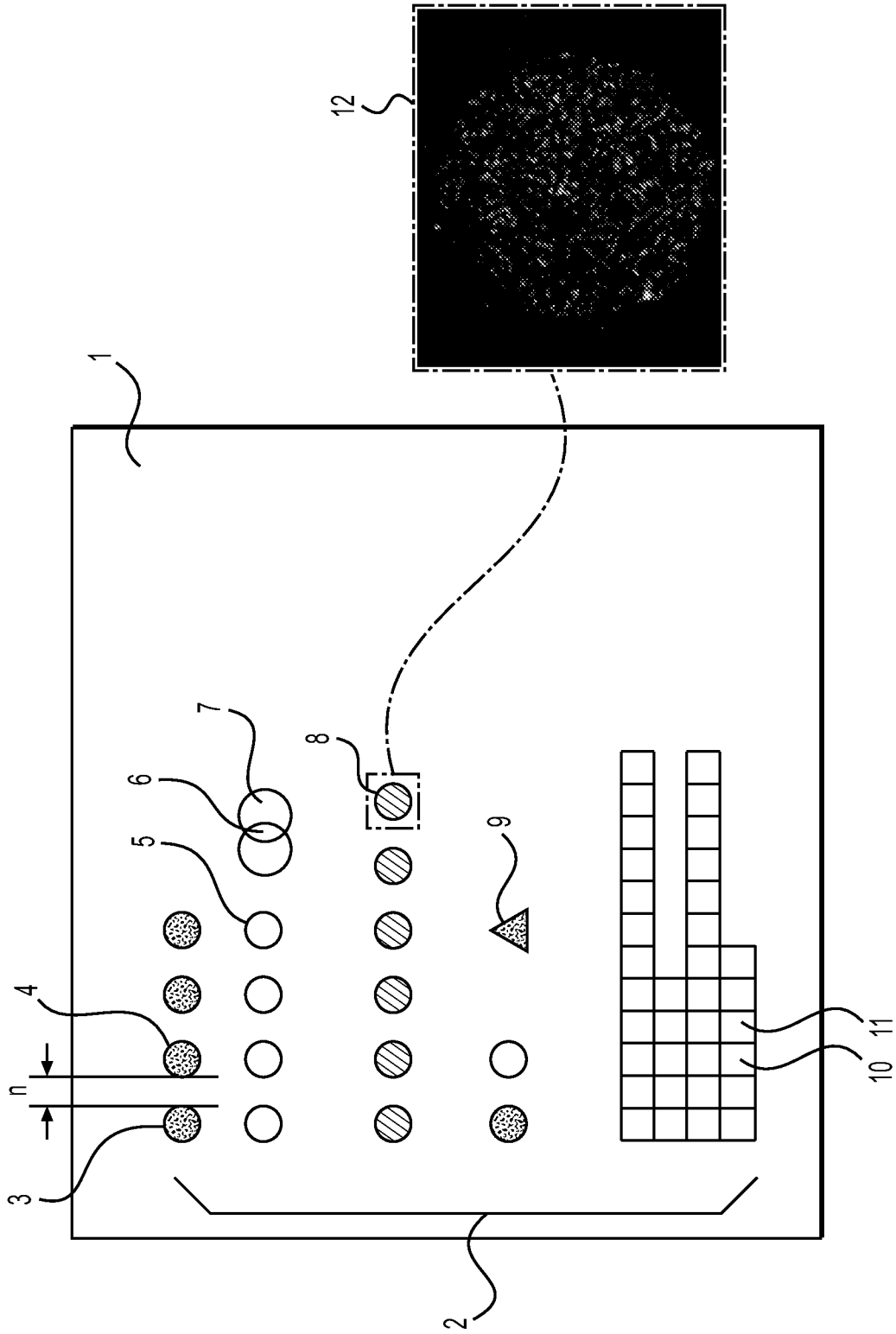


Figure 1

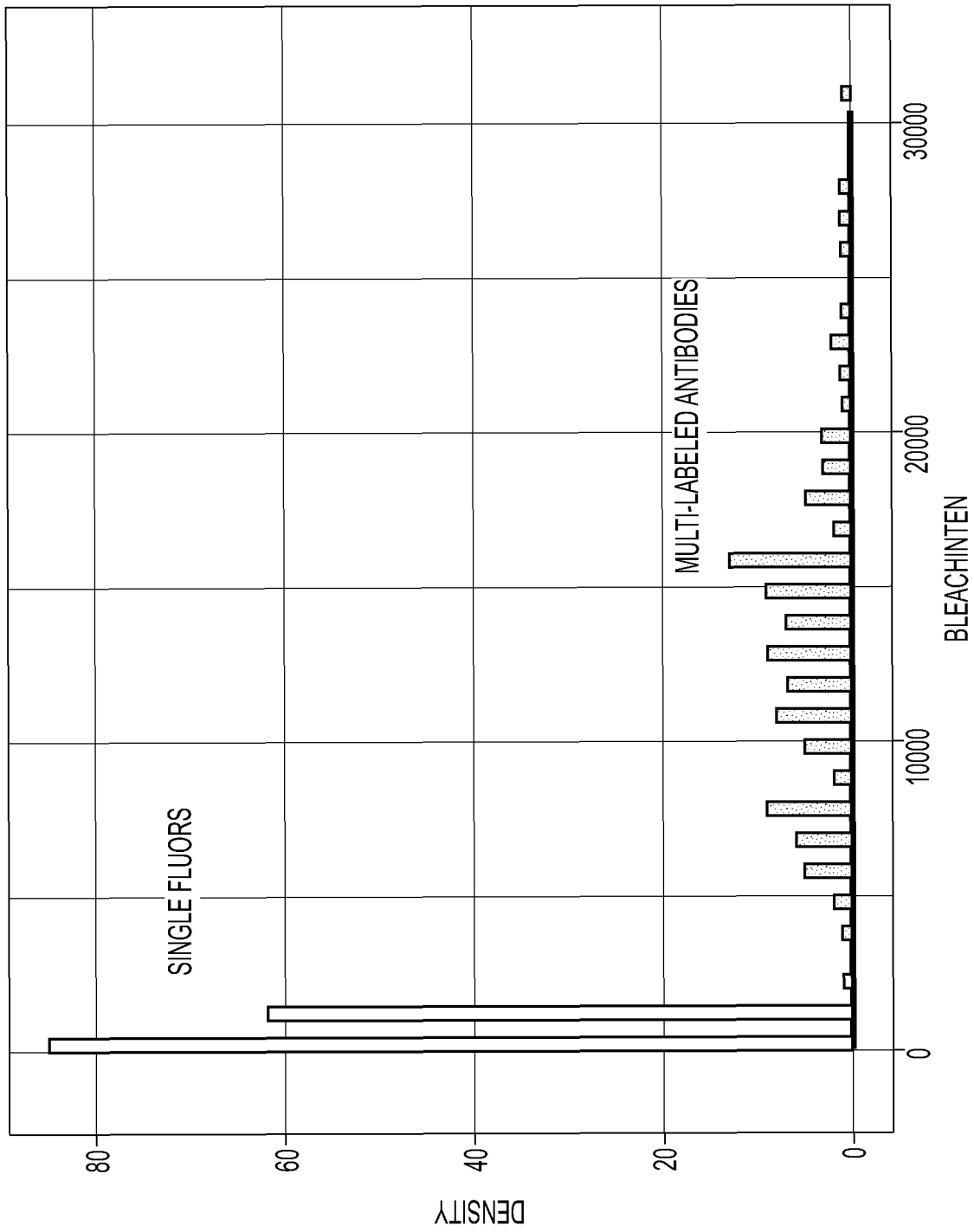


Figure 2

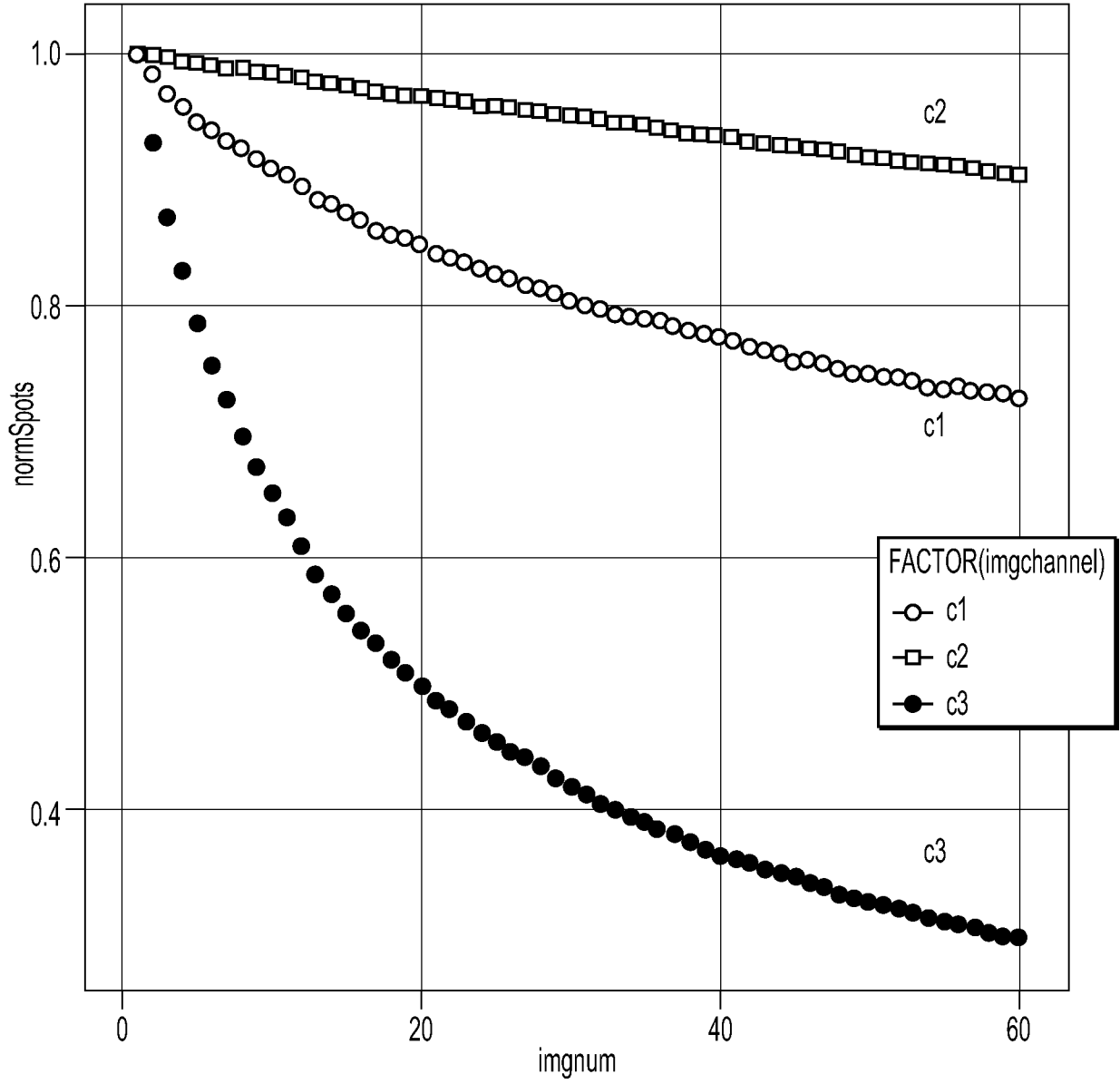


Figure 3

Figure 4

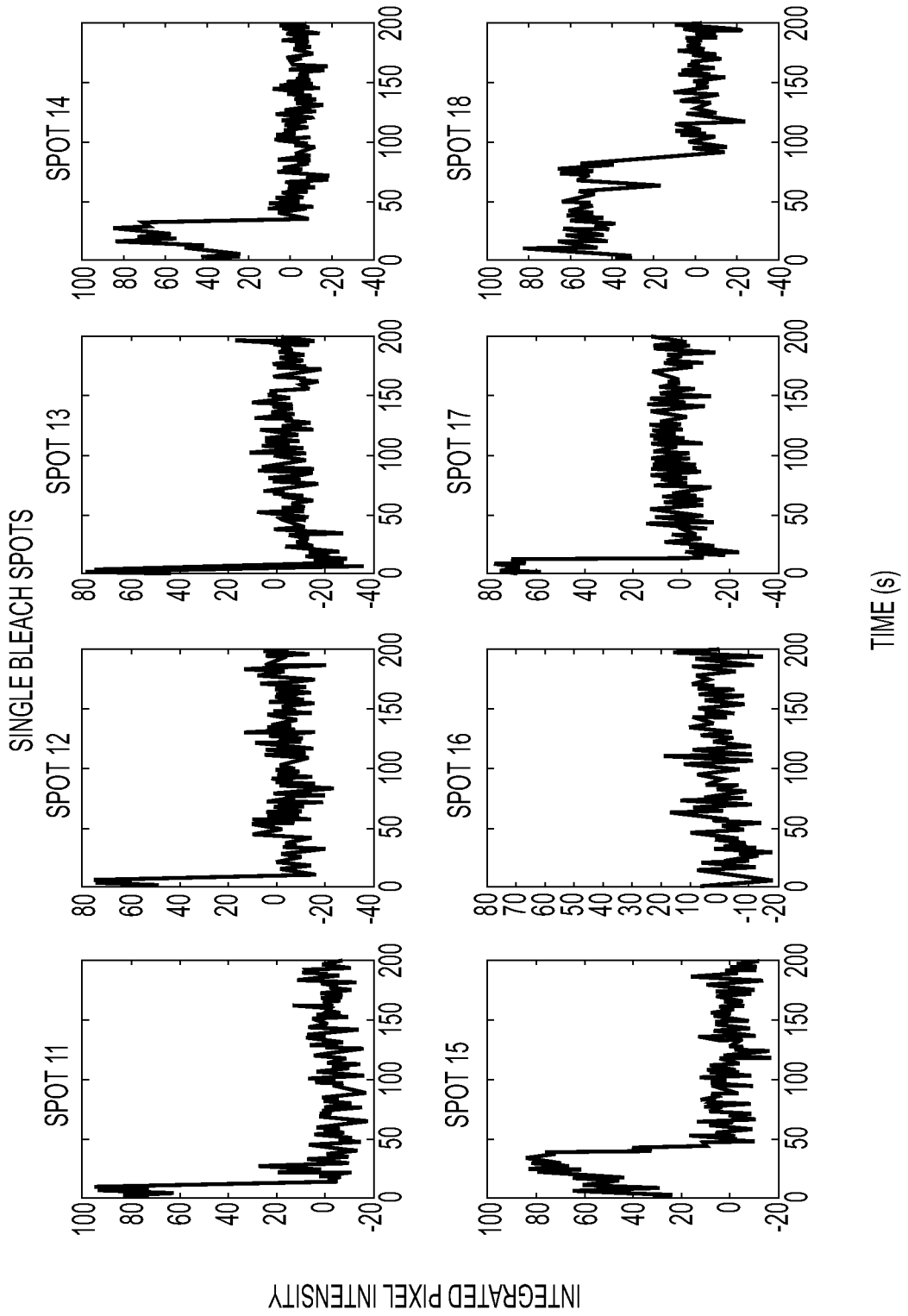


Figure 5

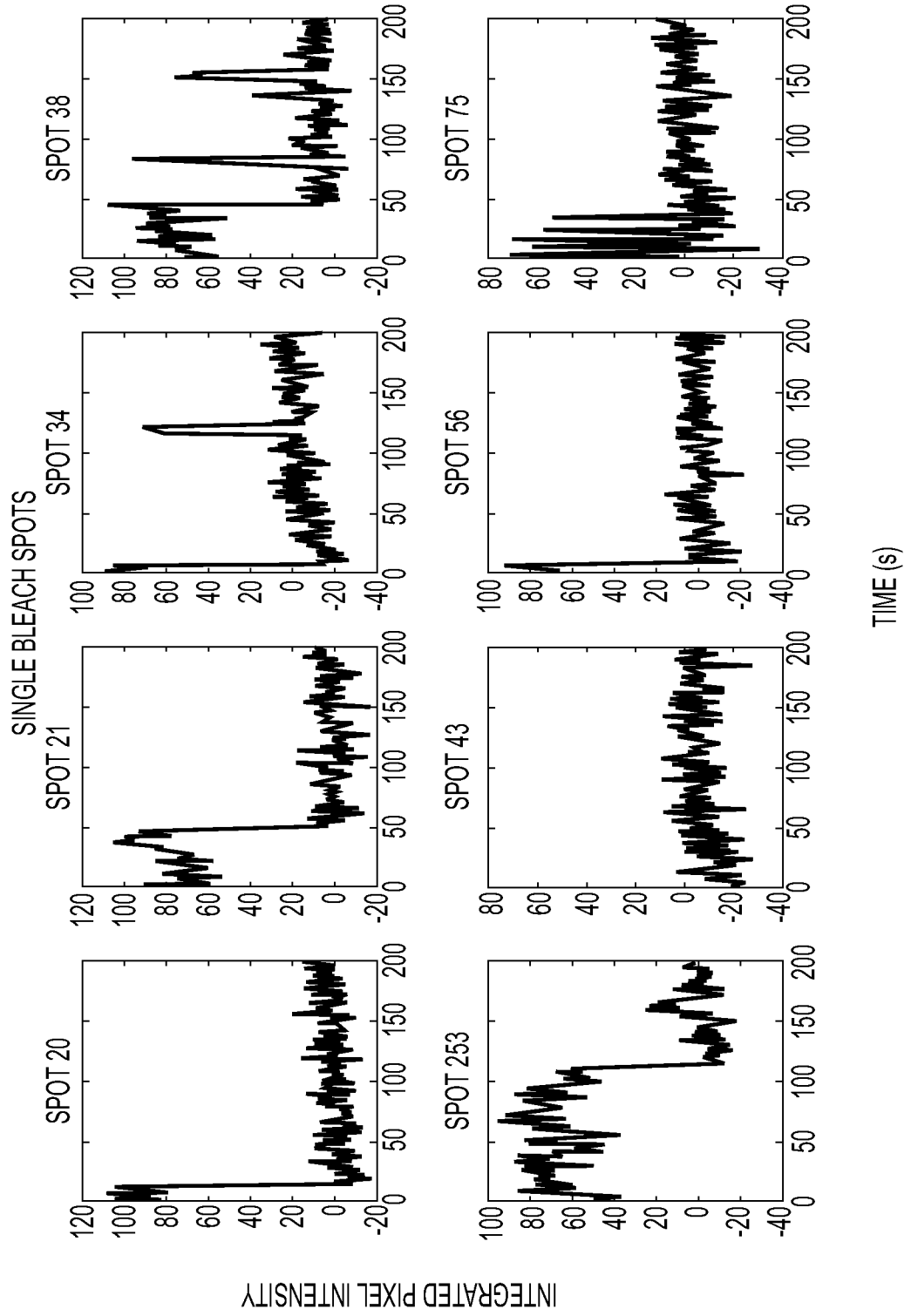


Figure 6

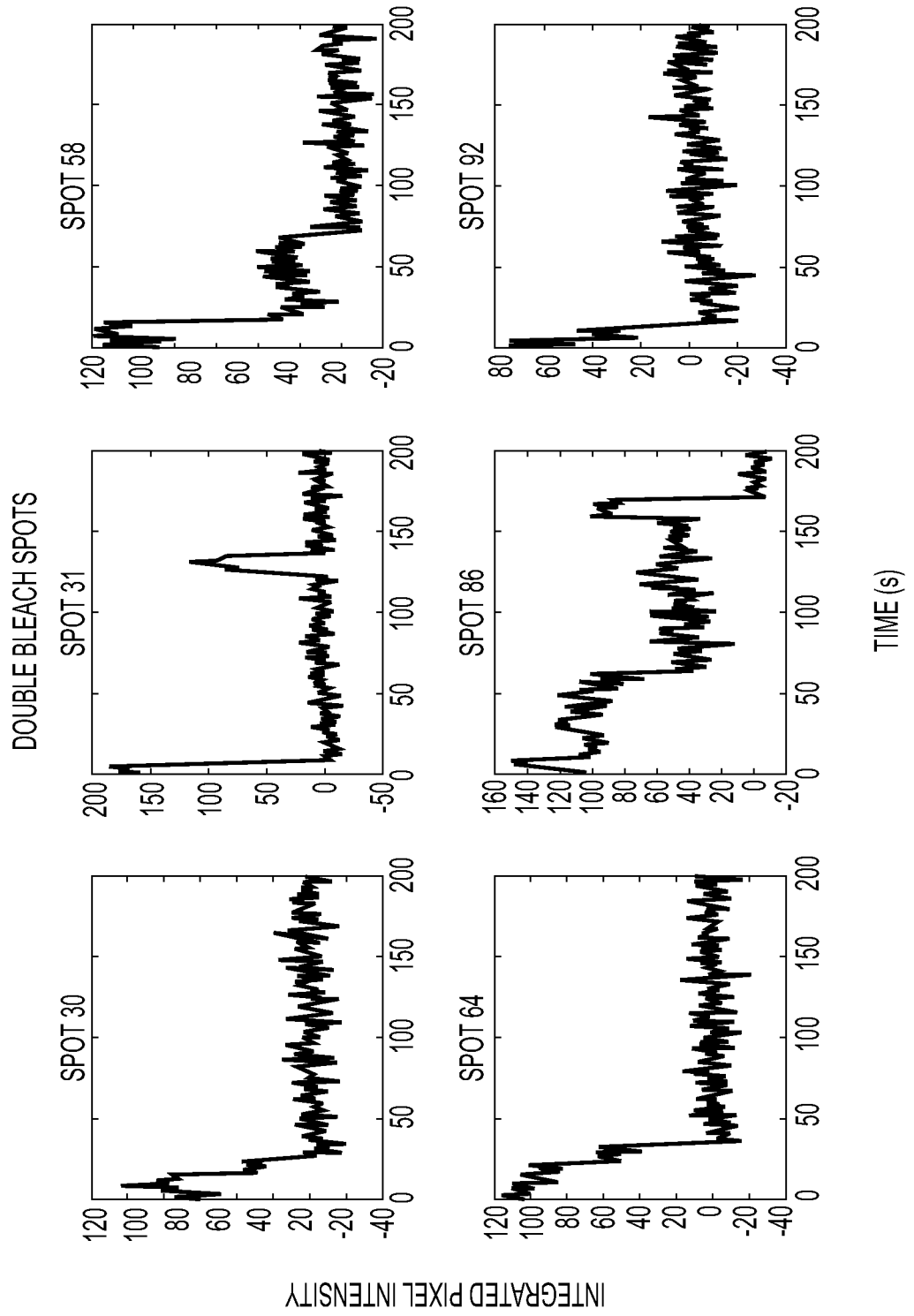


Figure 7

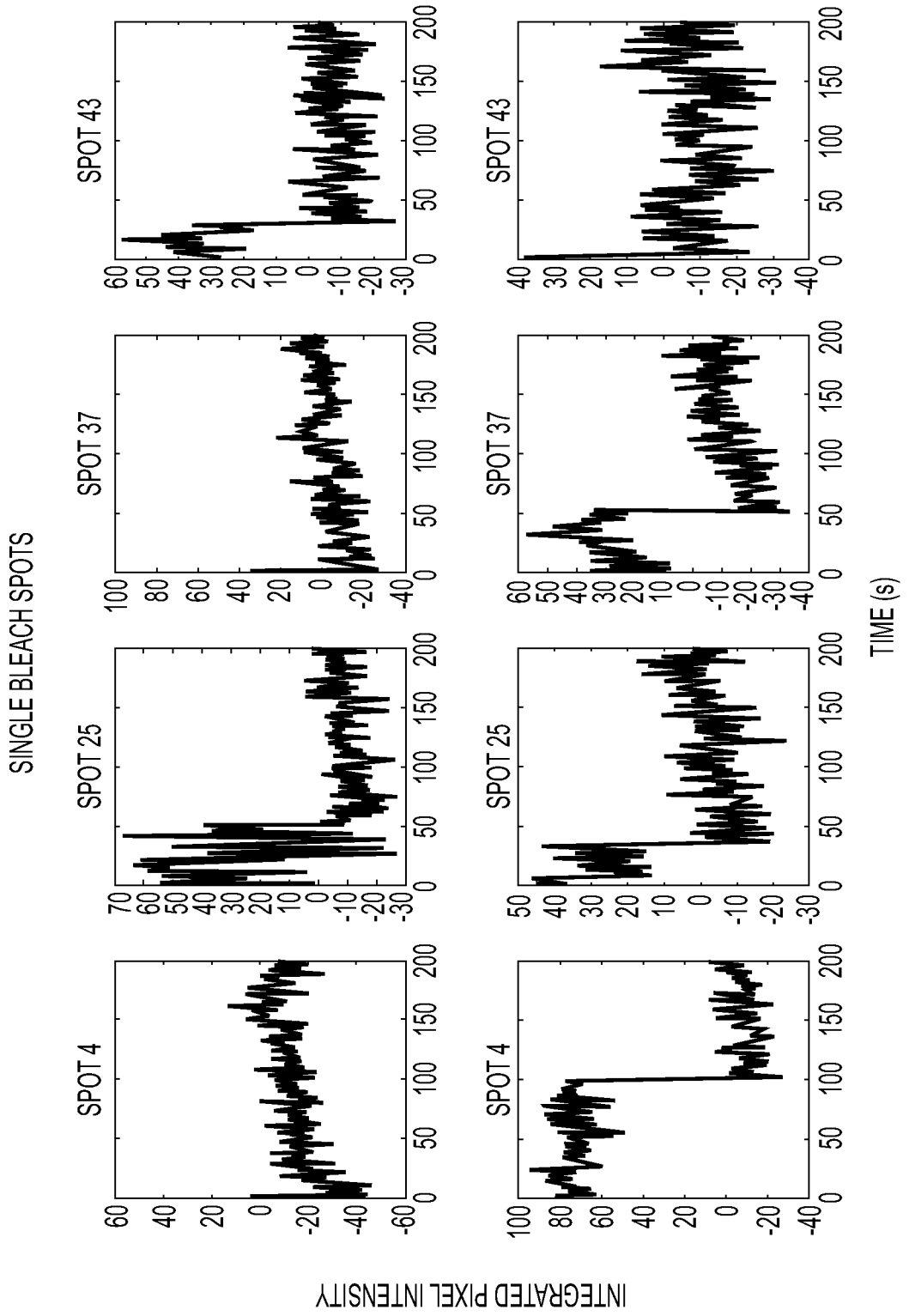


Figure 8

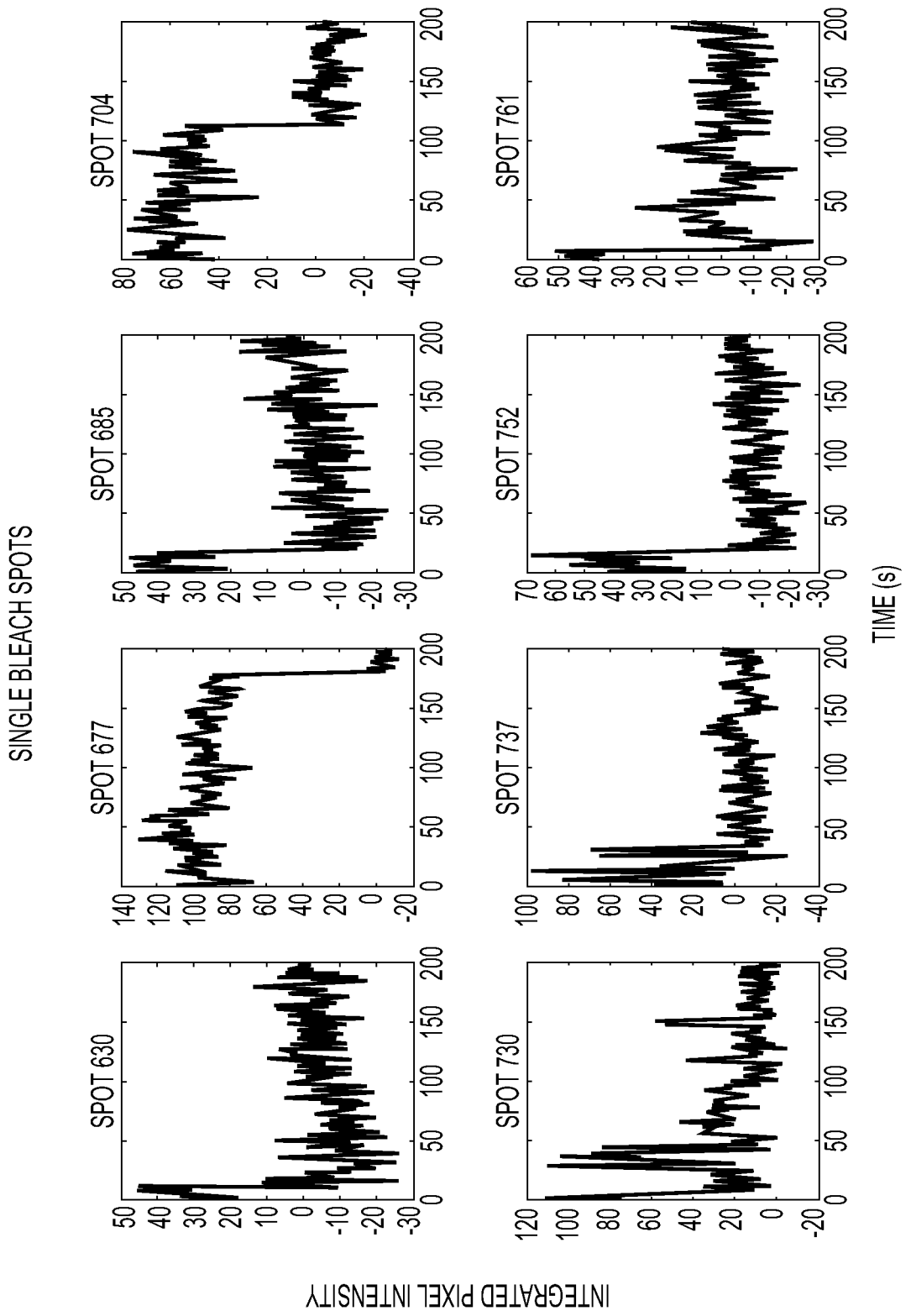


Figure 9

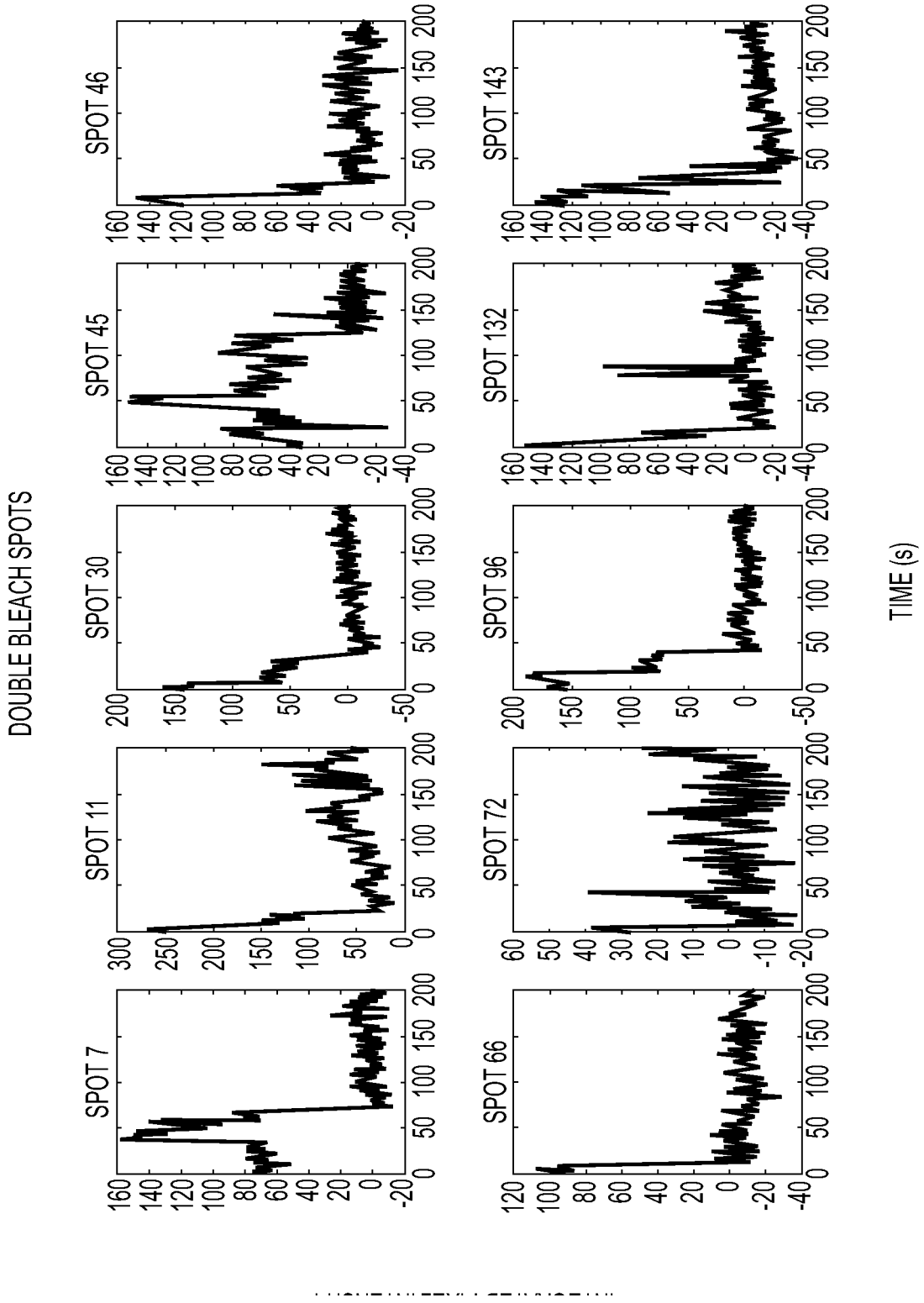


Figure 10

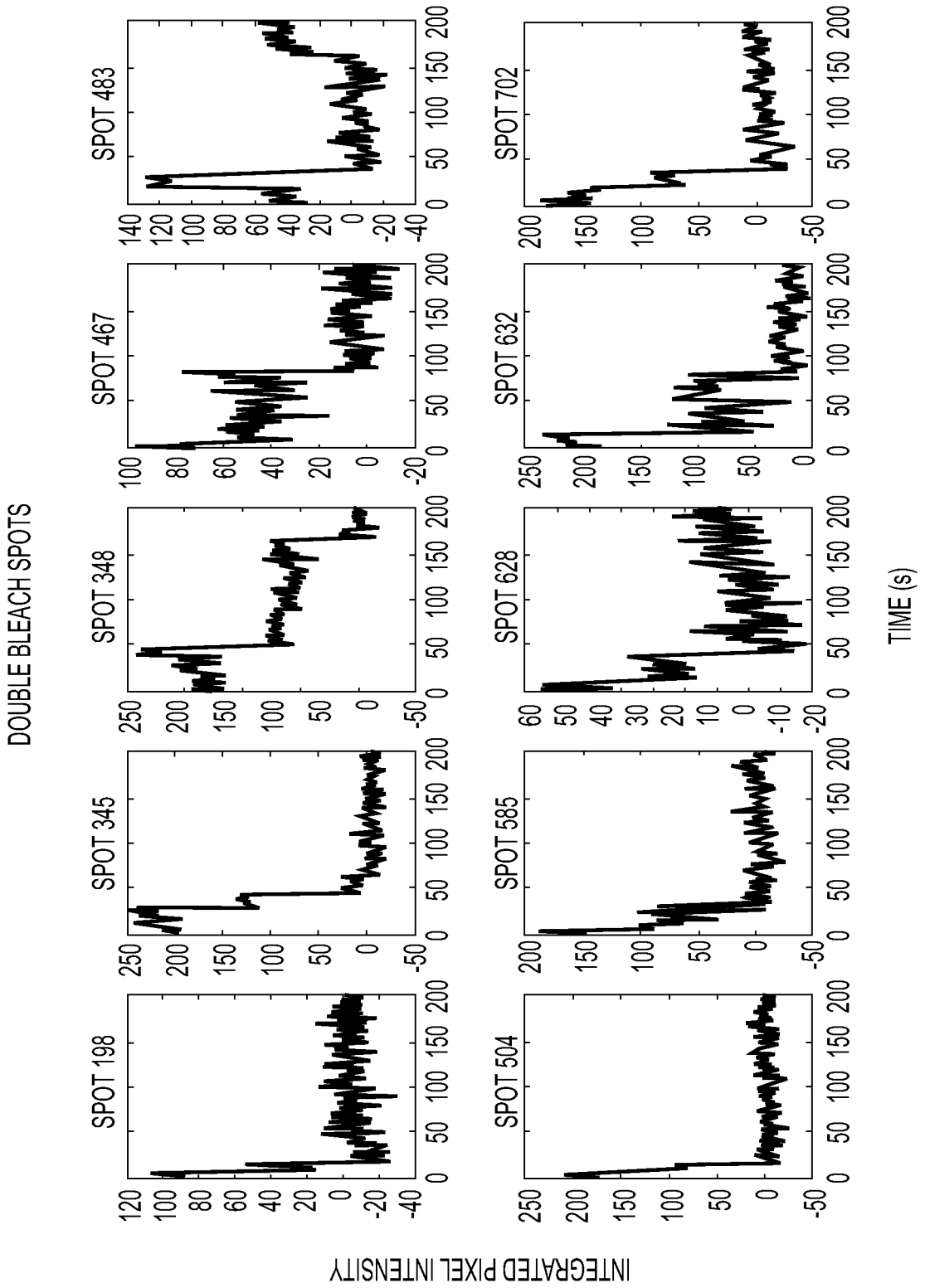


Figure 11

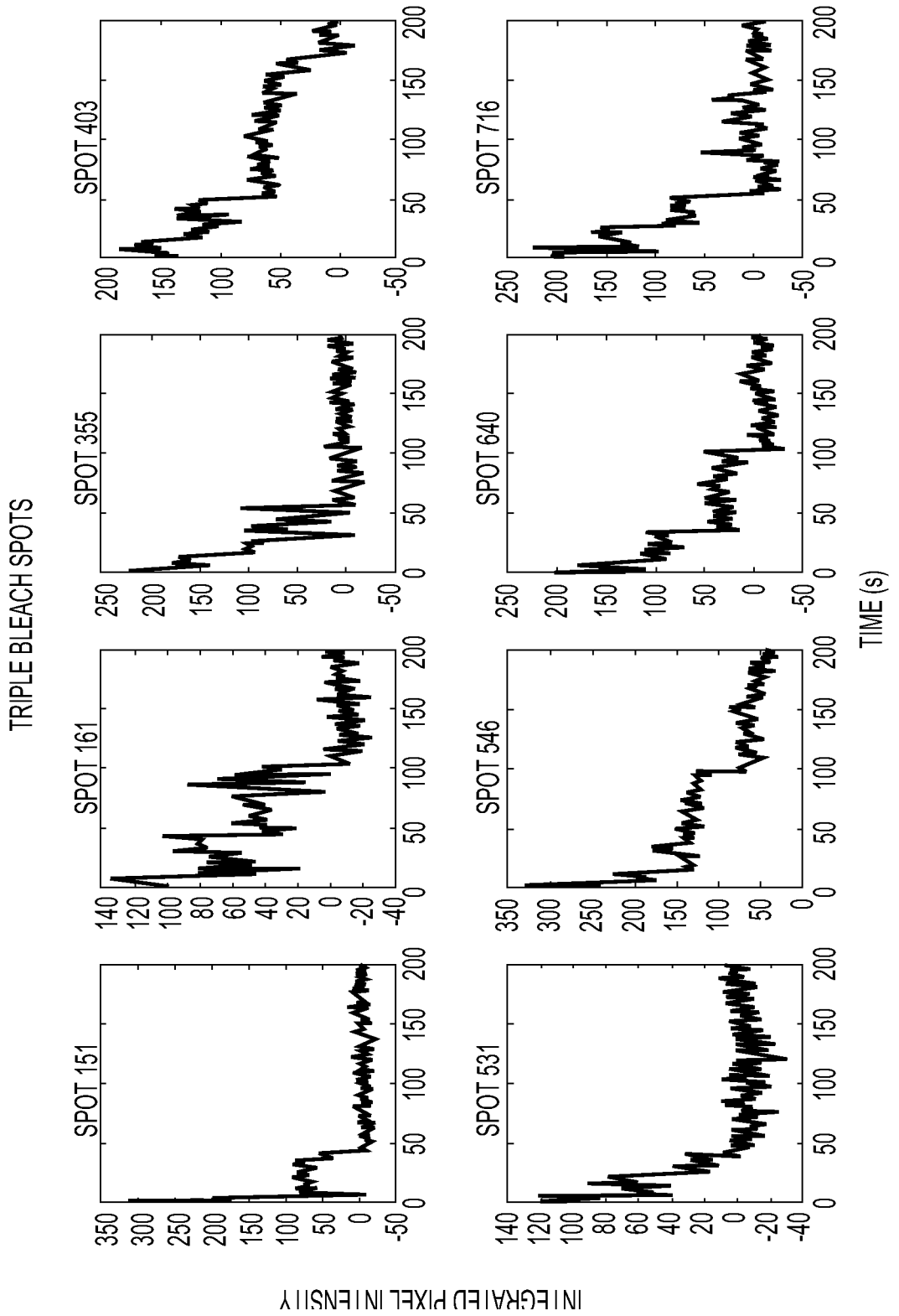


Figure 12

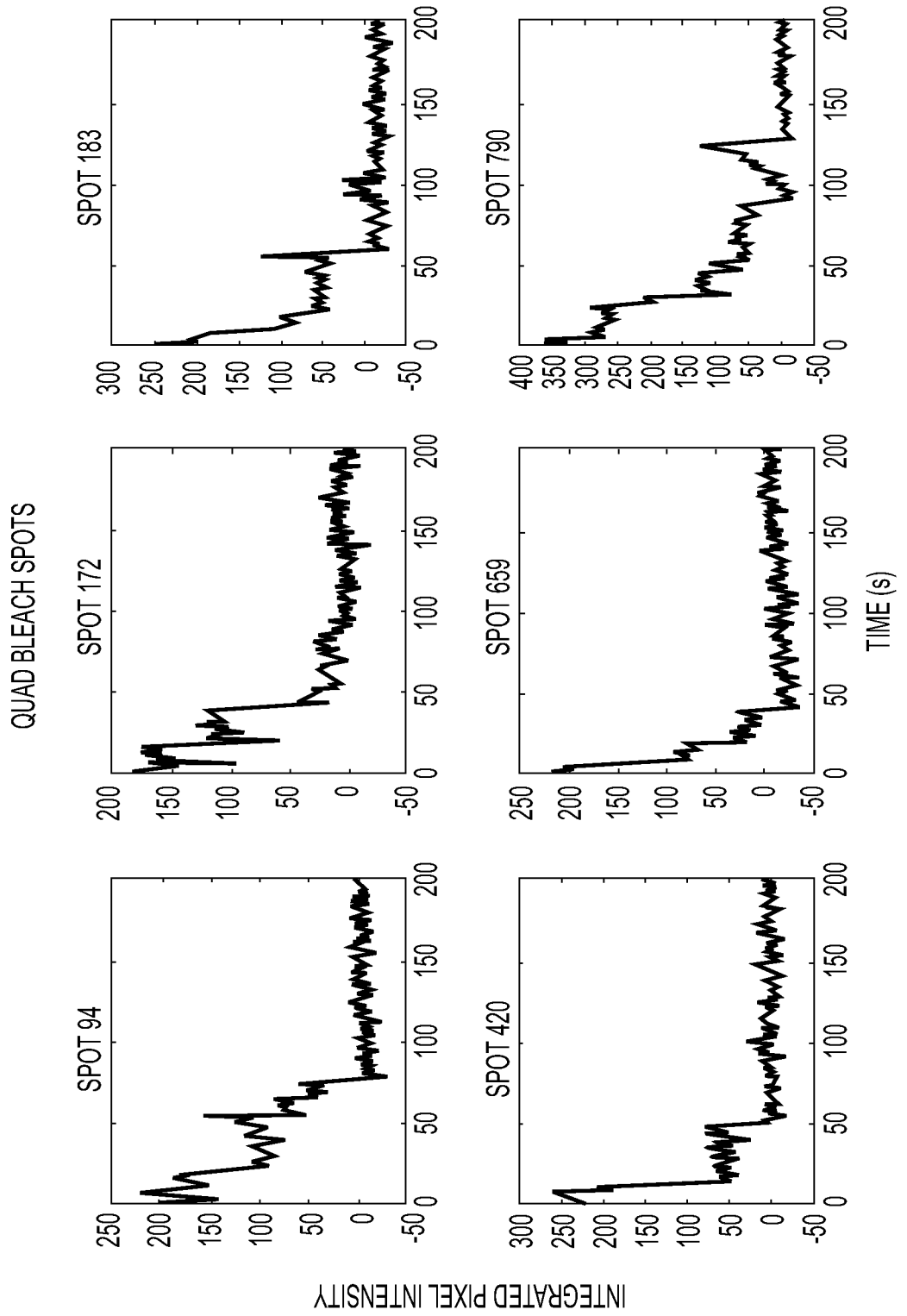
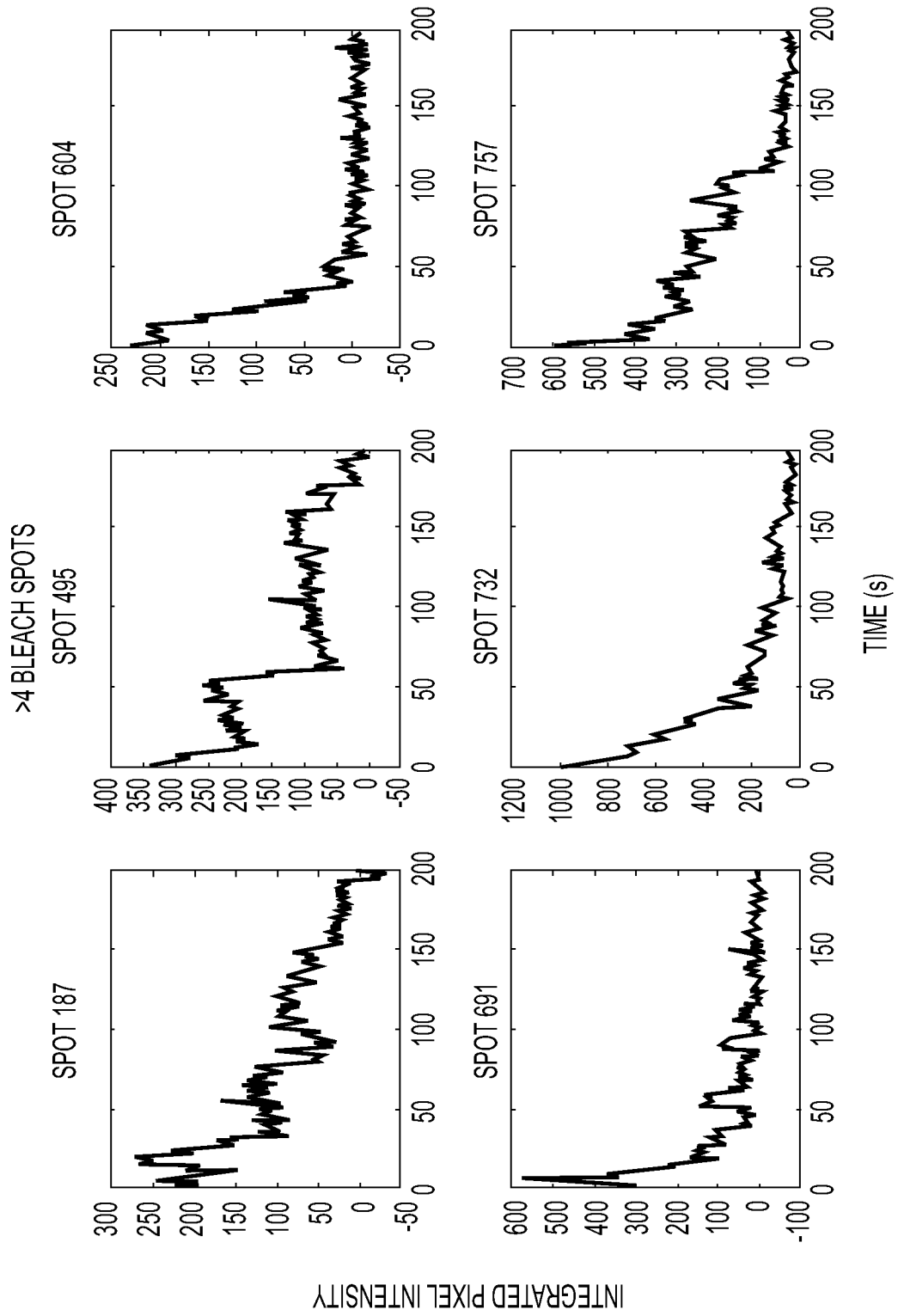


Figure 13



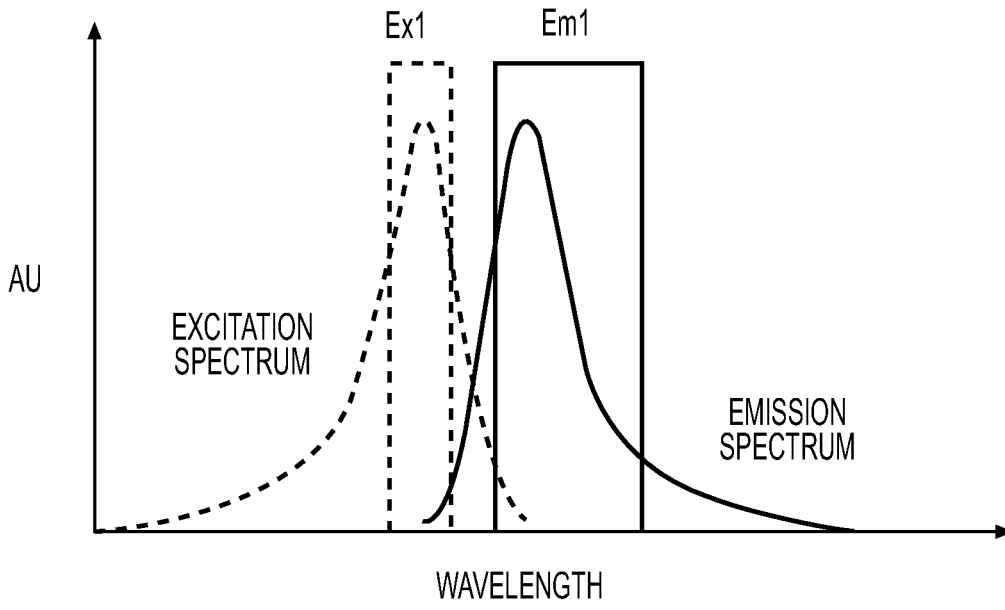


Figure 14

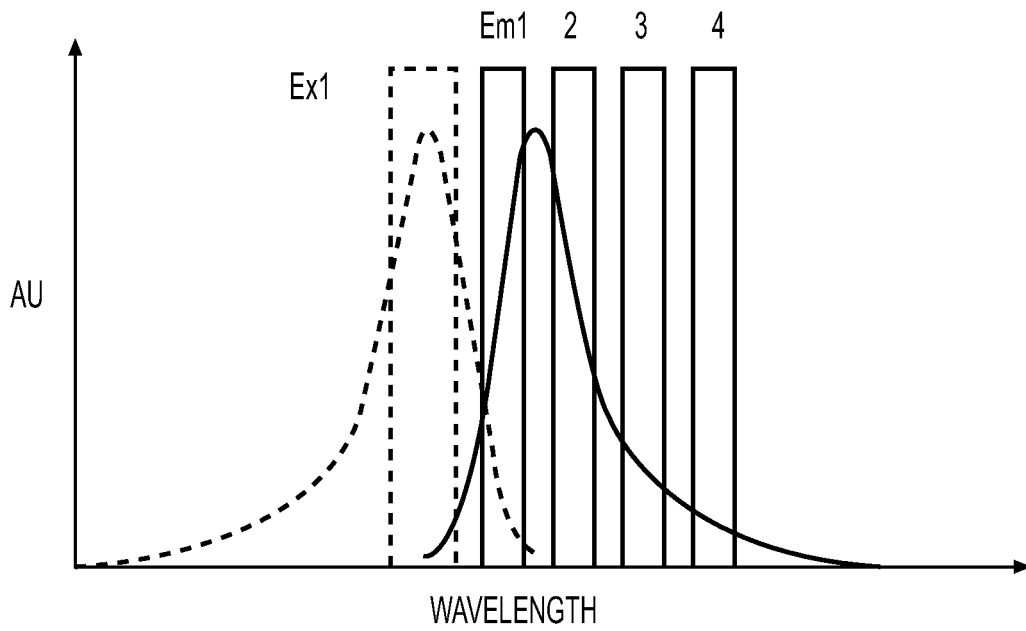
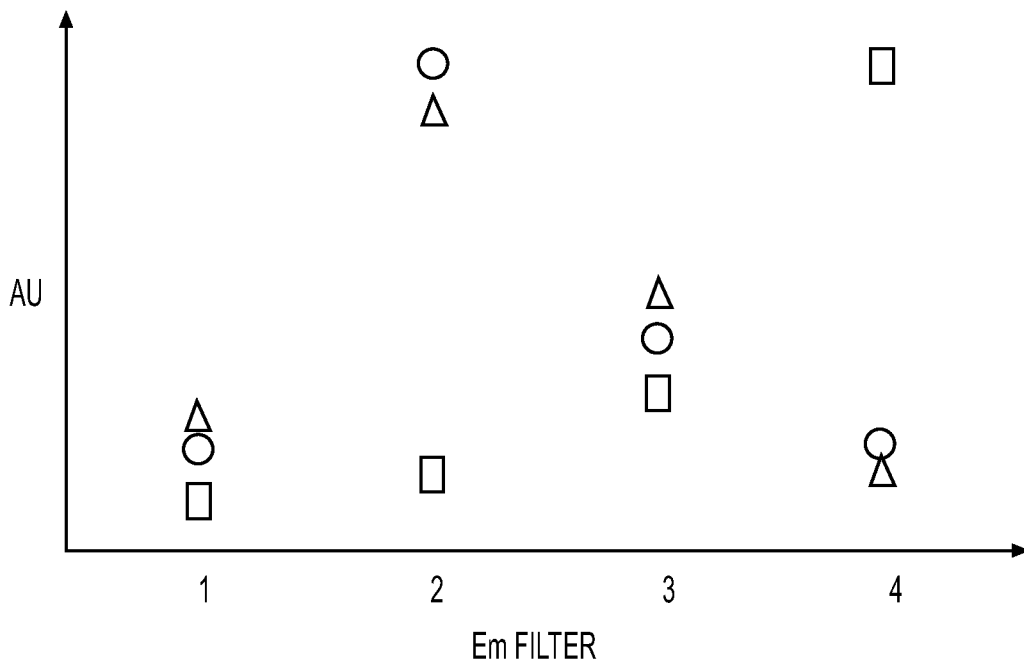
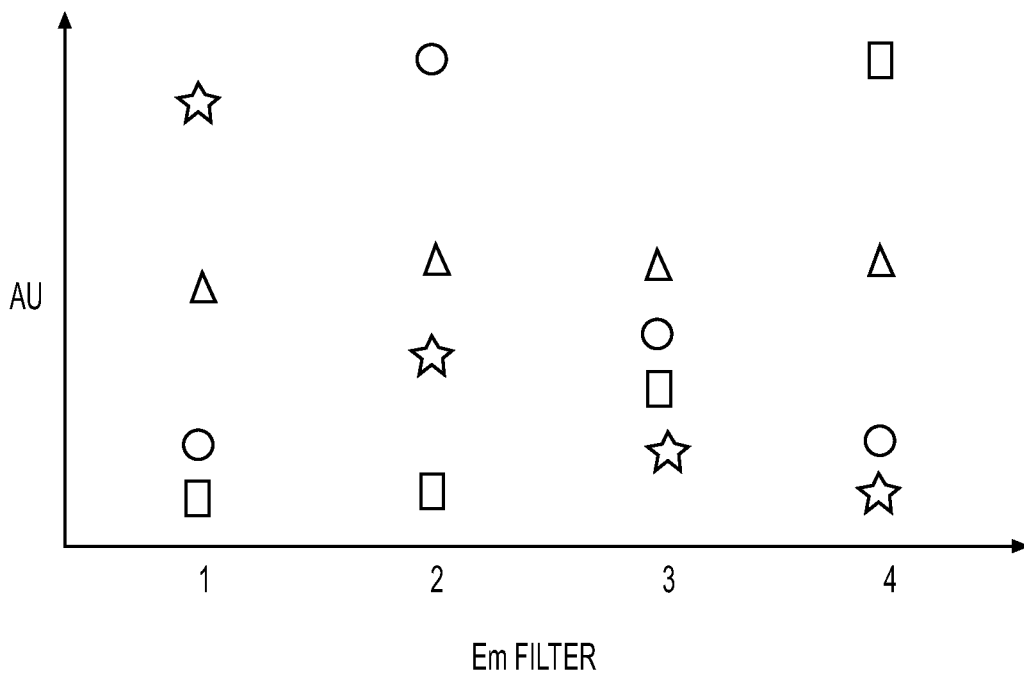


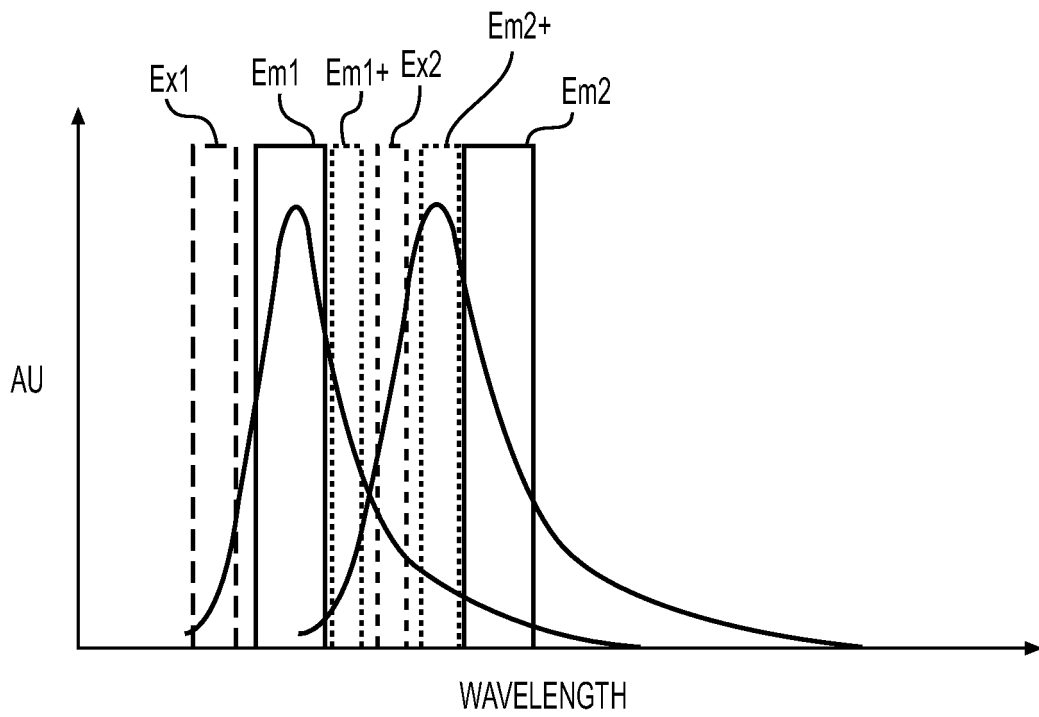
Figure 15



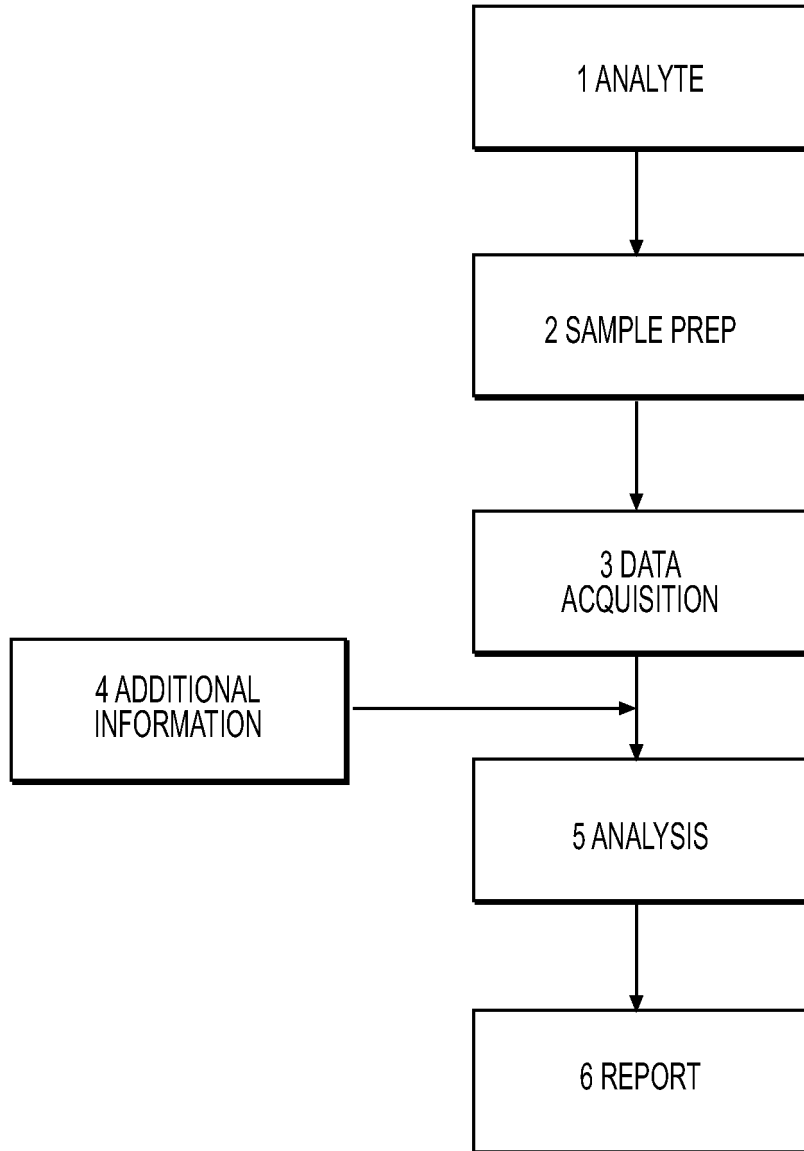
**Figure 16**



**Figure 17**



**Figure 18**



**Figure 19**

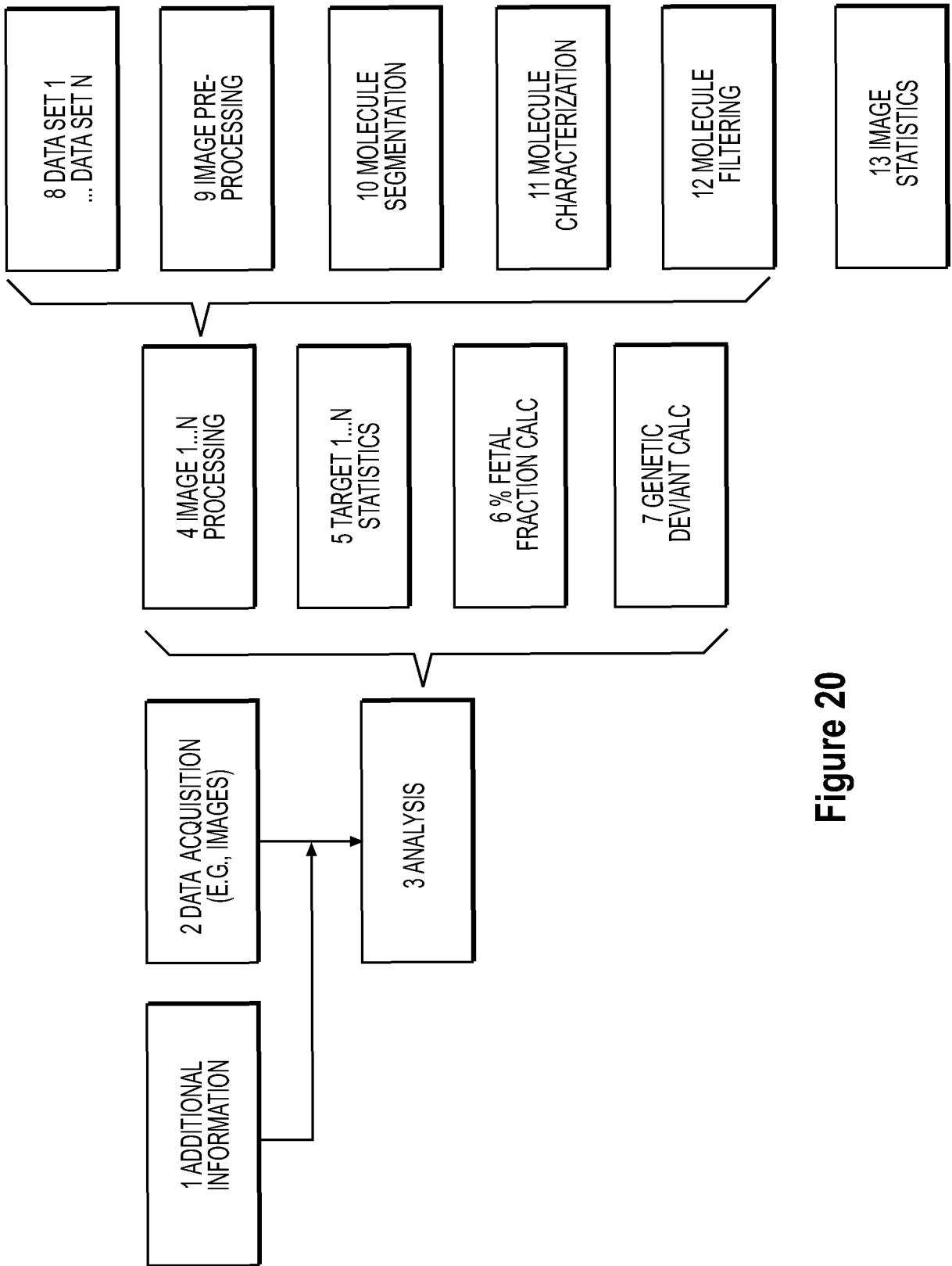


Figure 20

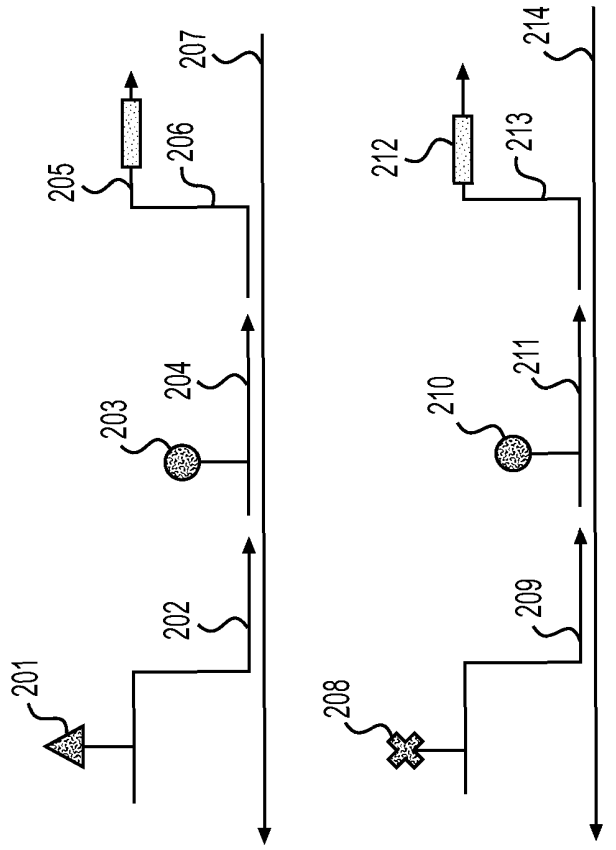


Figure 21

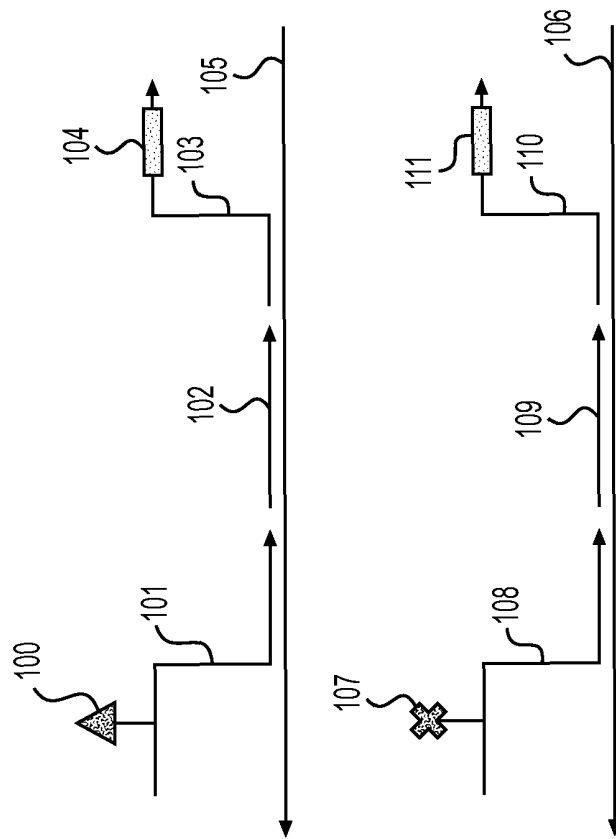


Figure 22

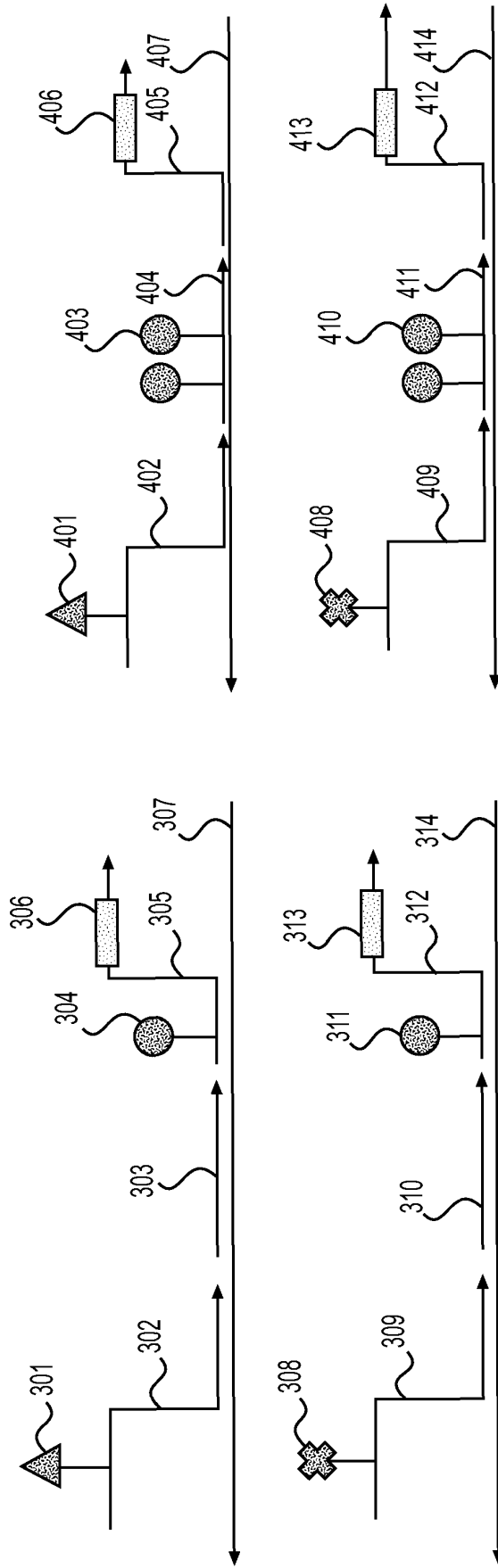


Figure 24

Figure 23

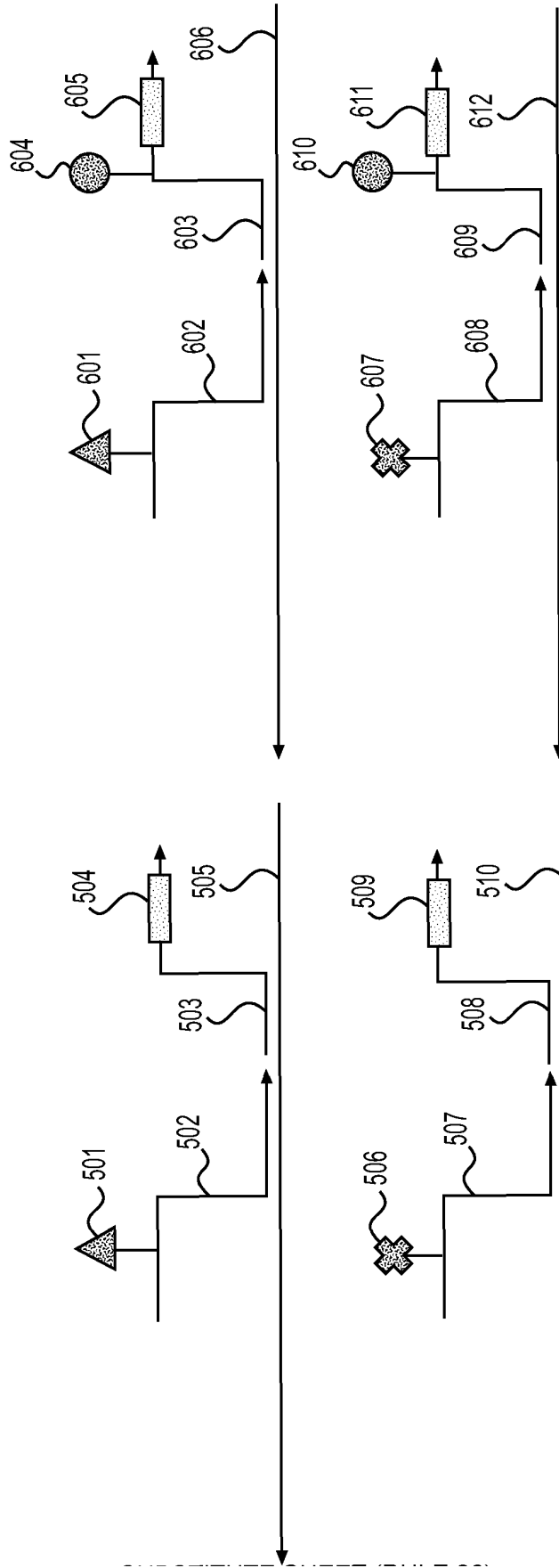


Figure 26

Figure 25

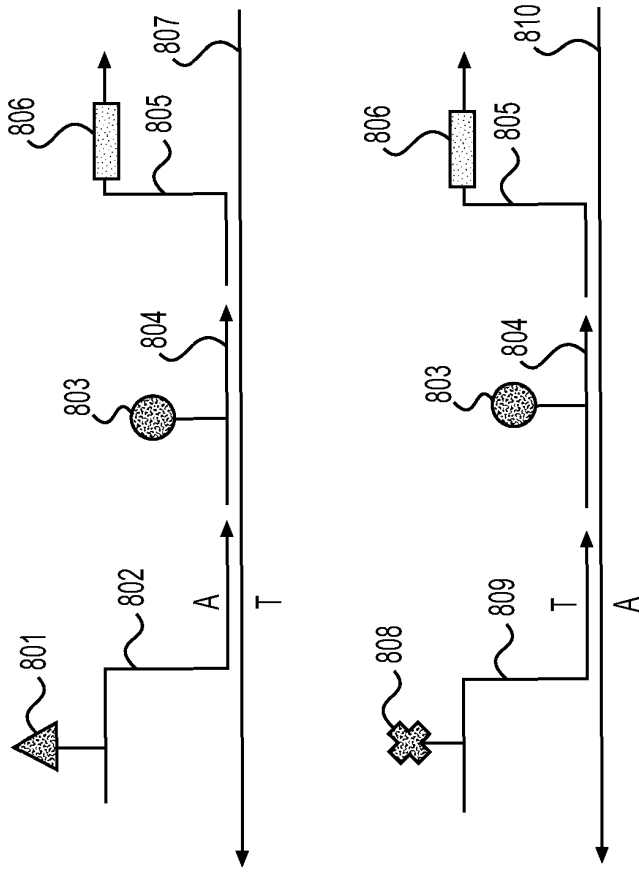


Figure 27

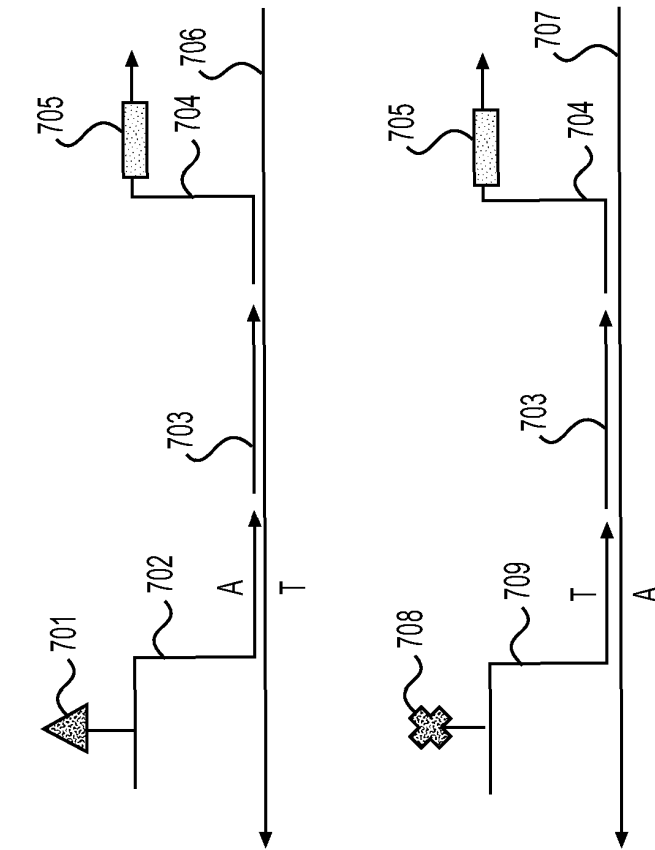


Figure 28

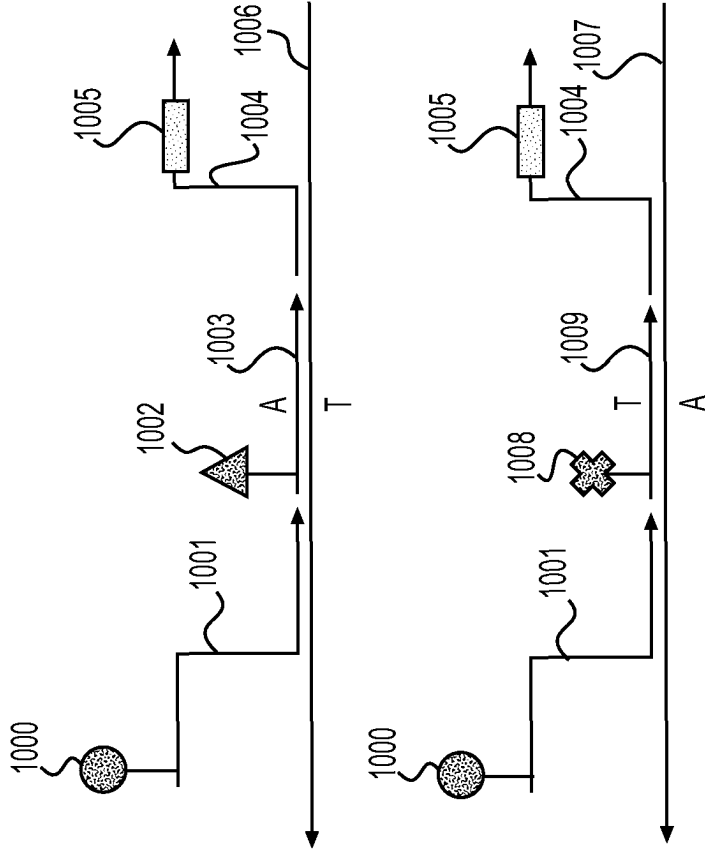


Figure 29

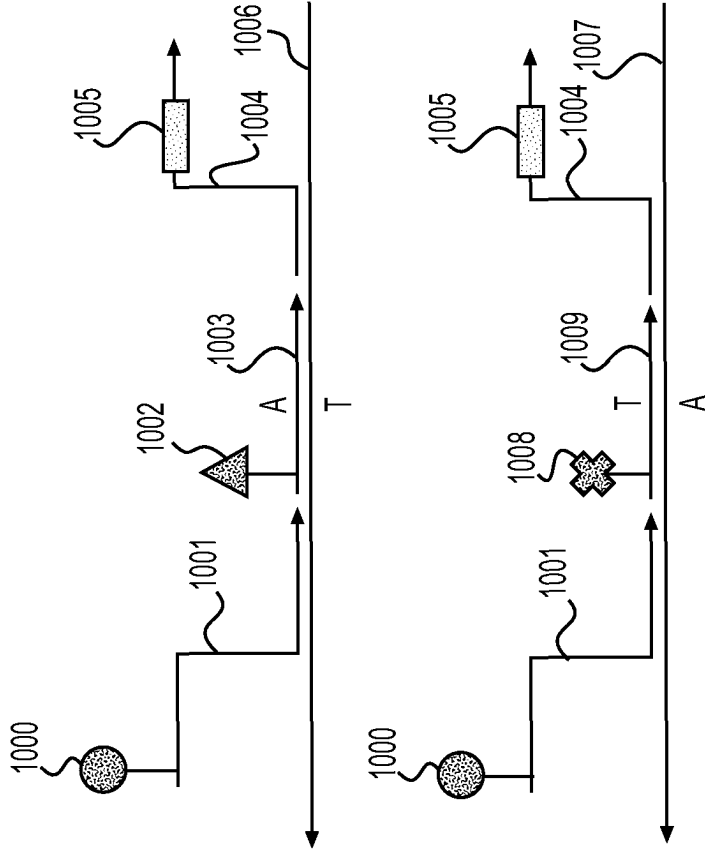


Figure 30

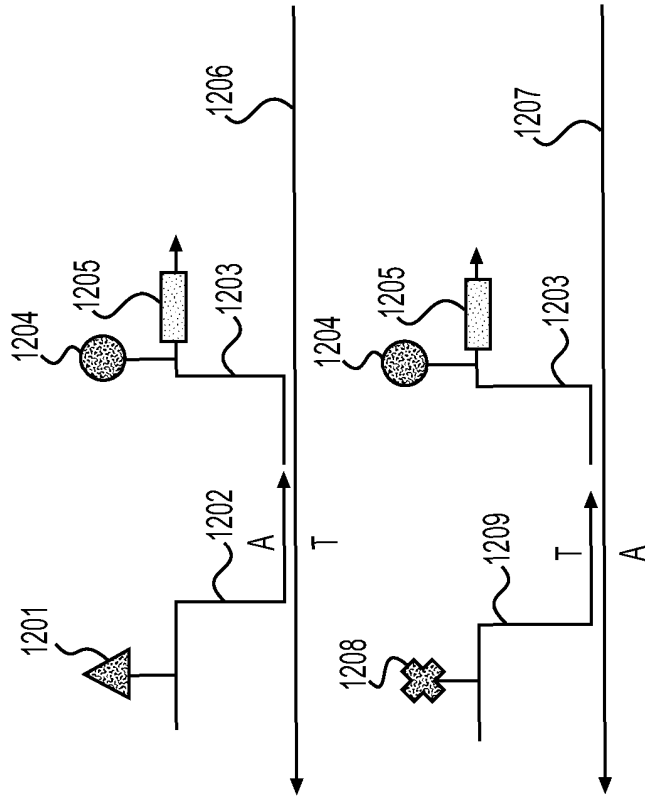


Figure 31

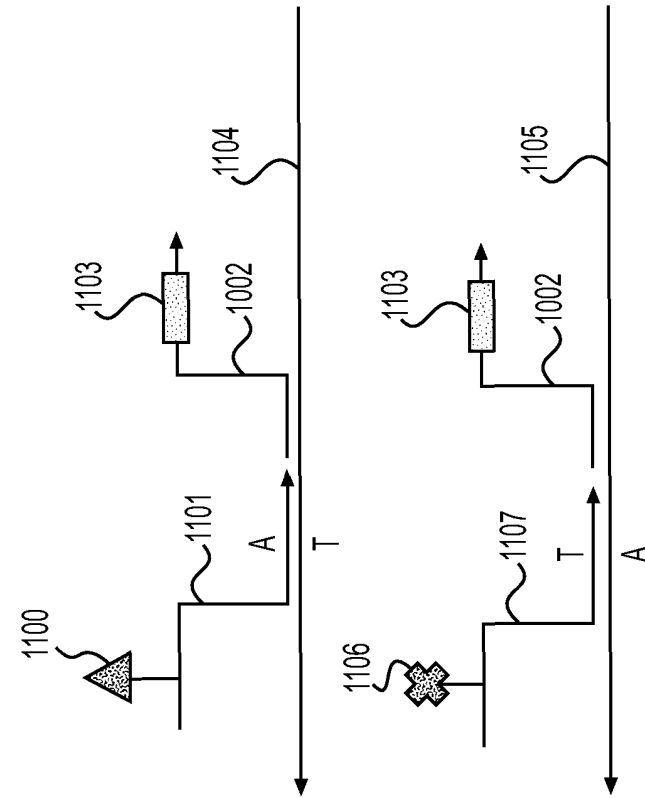


Figure 32

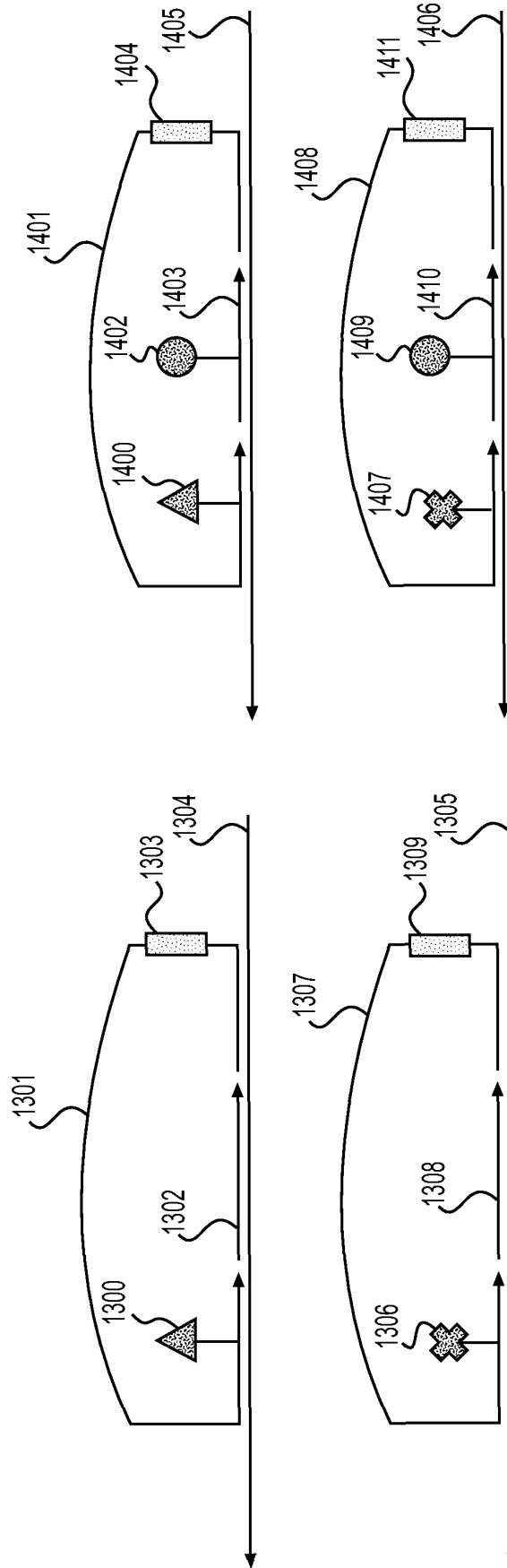


Figure 34

Figure 33

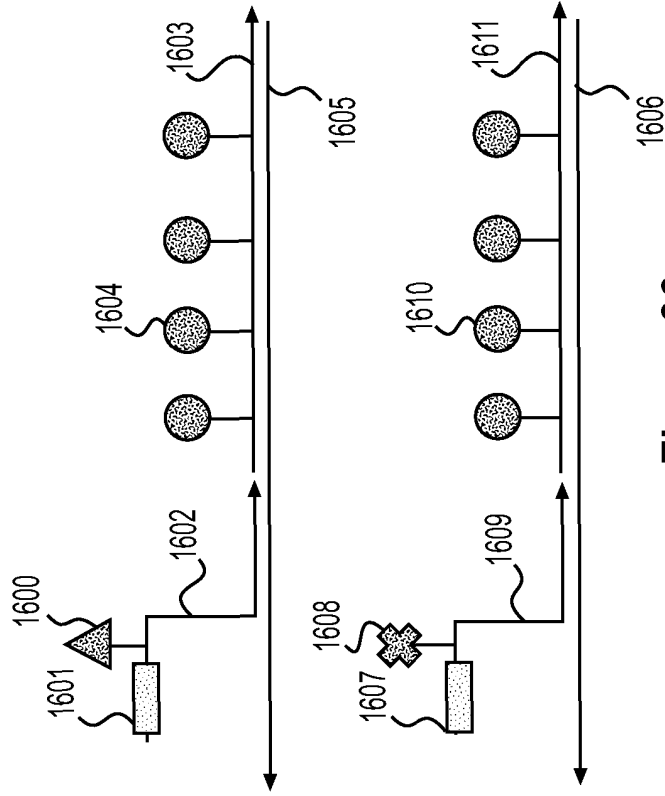


Figure 36

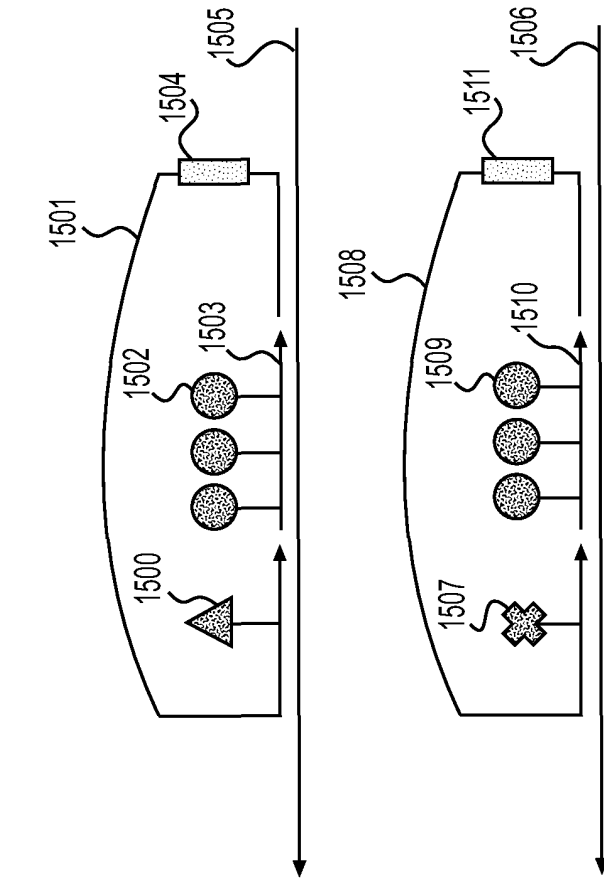


Figure 35

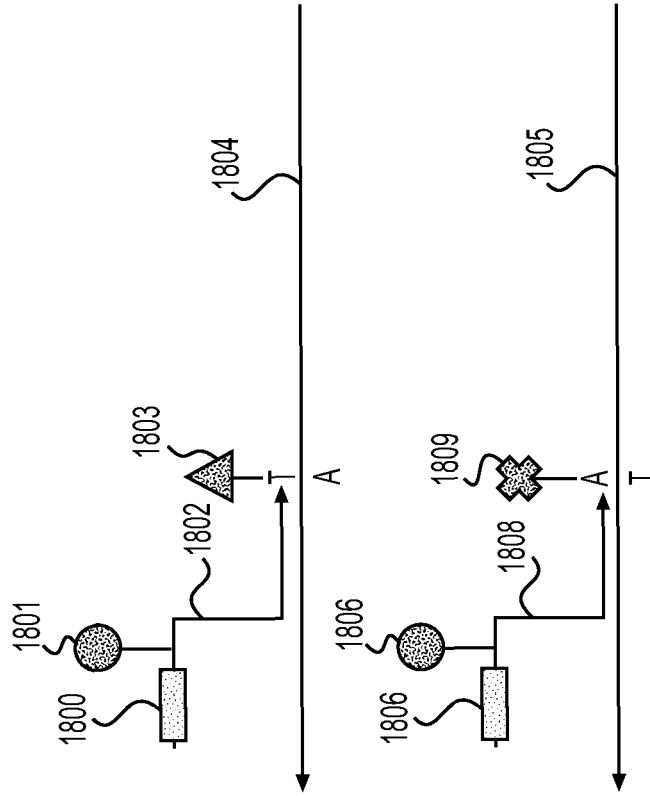


Figure 38

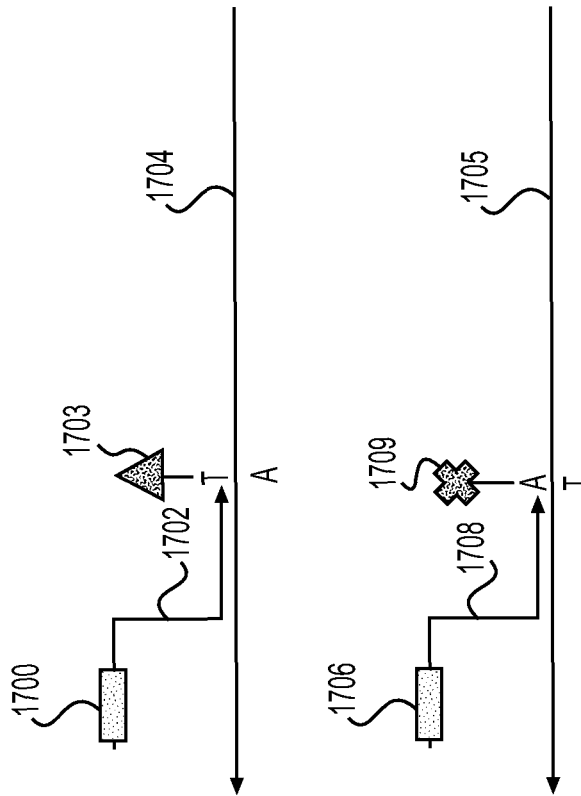


Figure 37

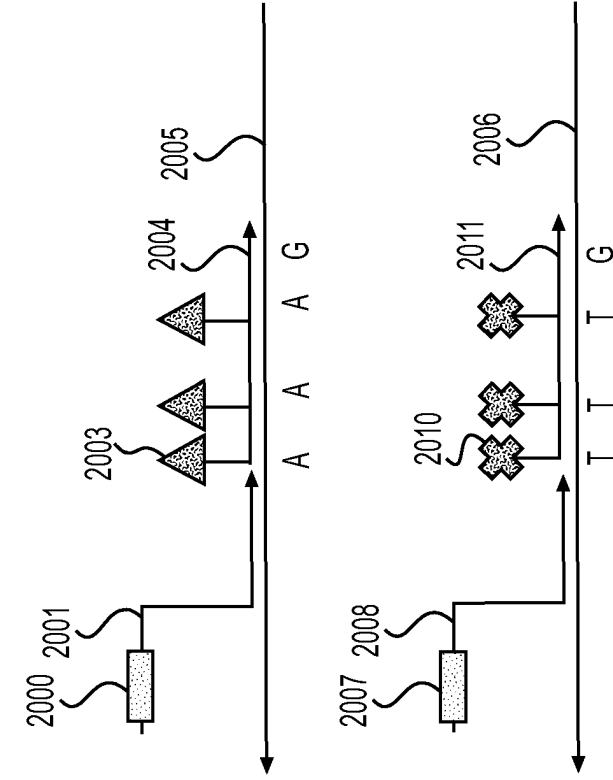


Figure 40

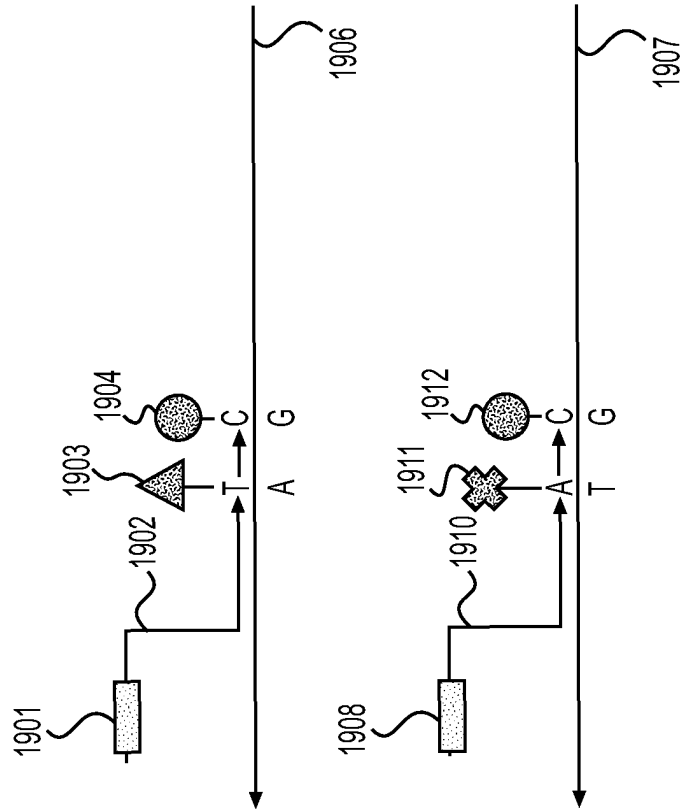


Figure 39

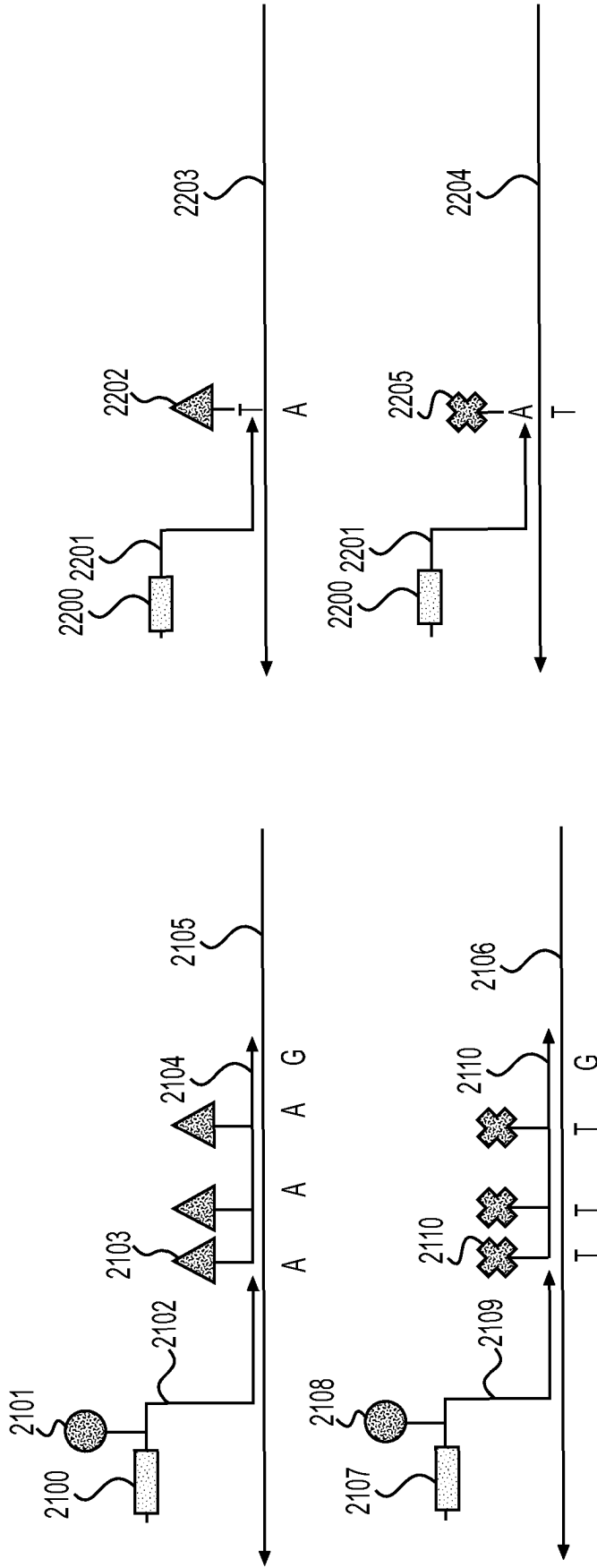


Figure 42

Figure 41

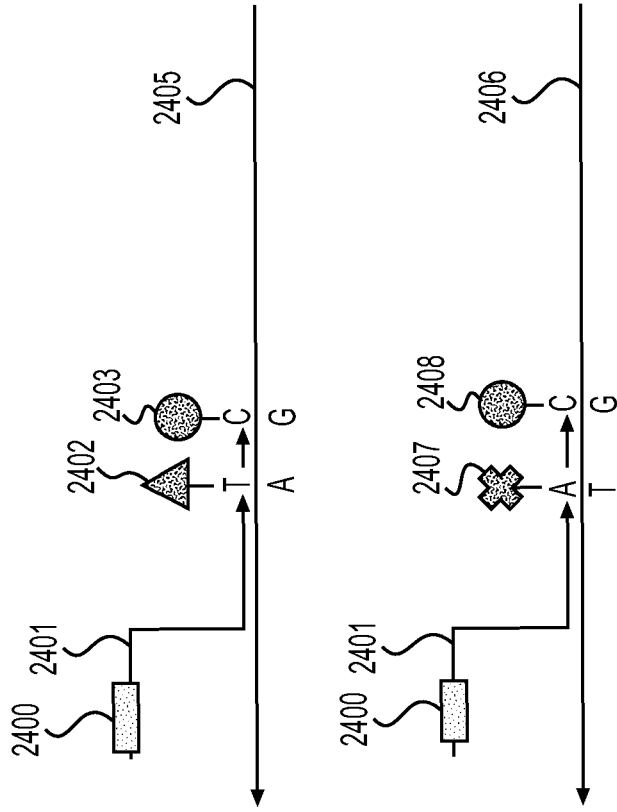


Figure 44

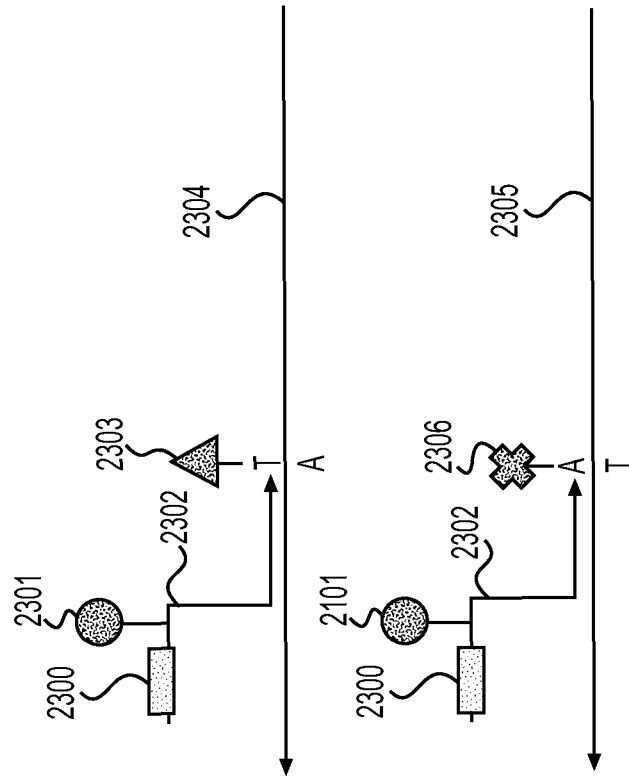


Figure 43

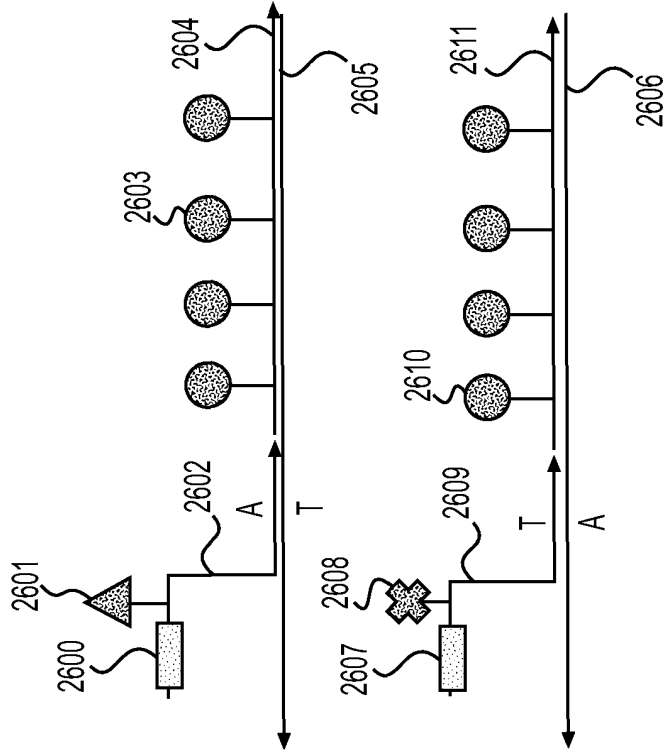


Figure 45

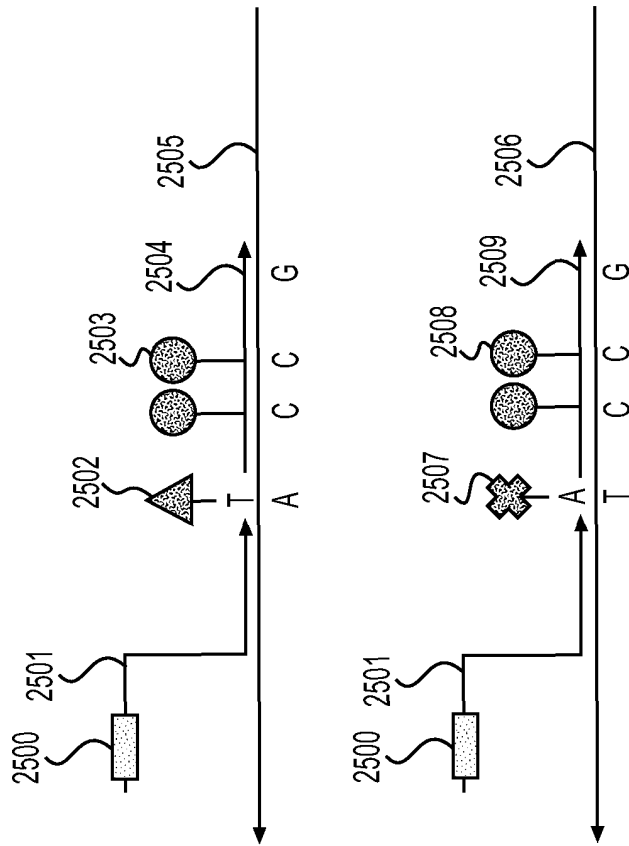


Figure 46

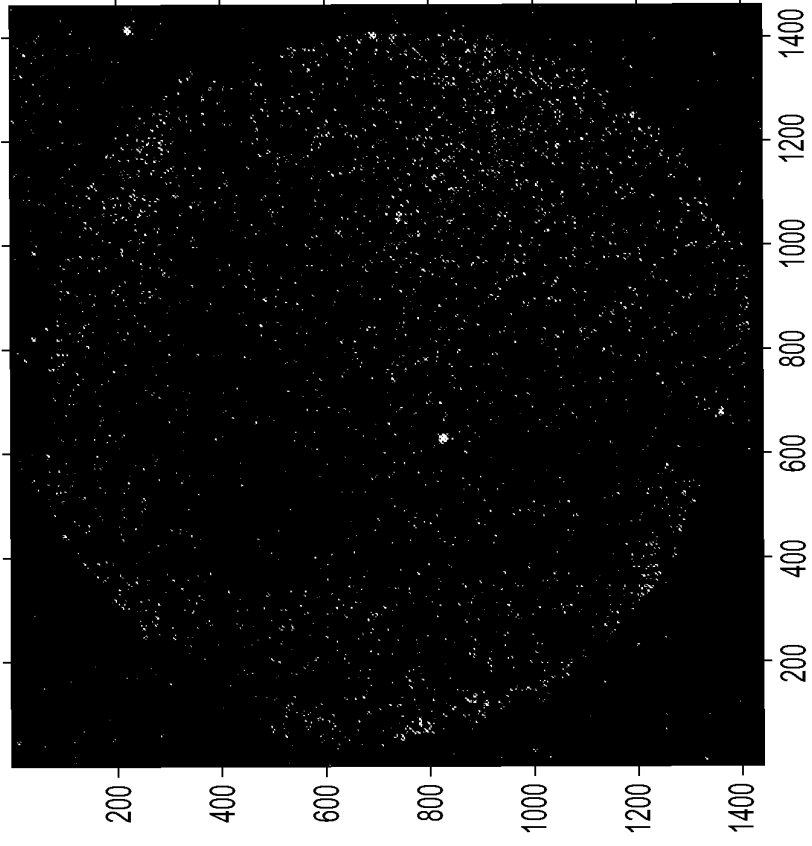


Figure 48

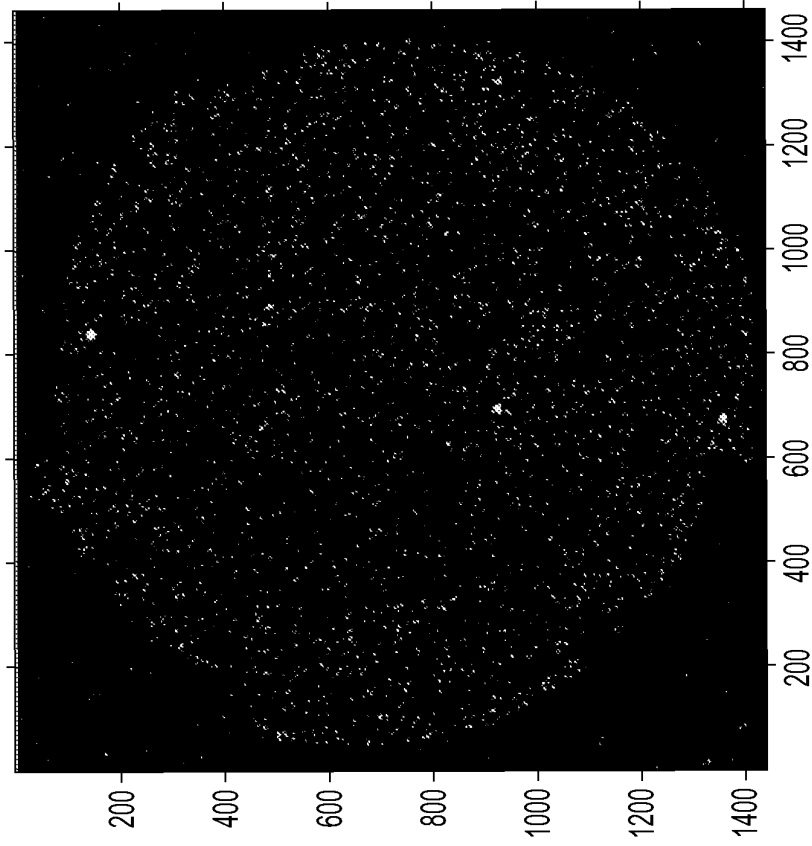
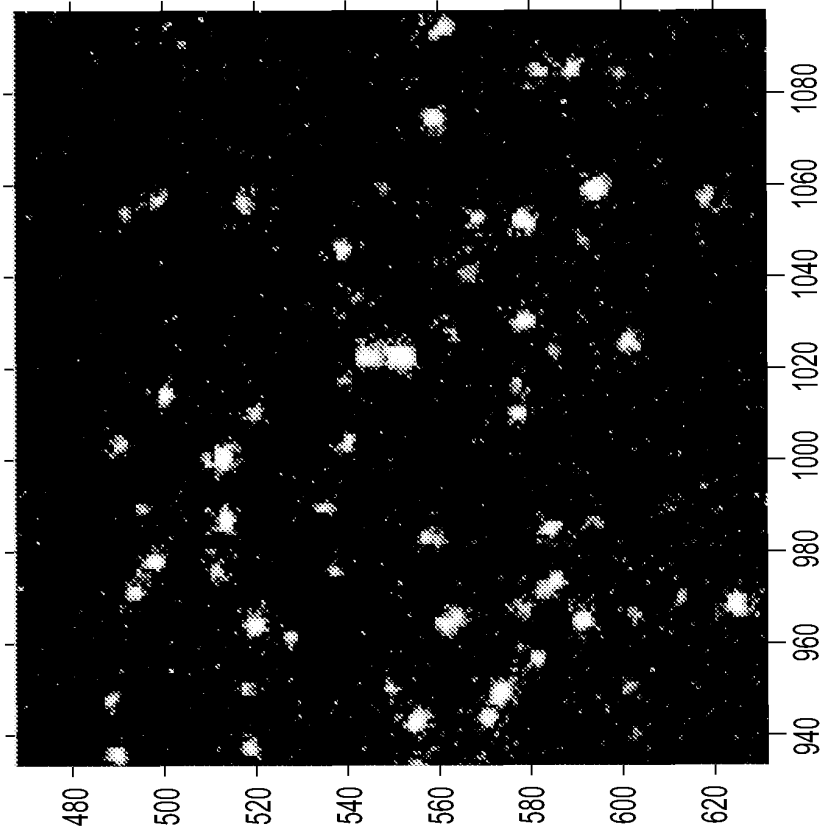
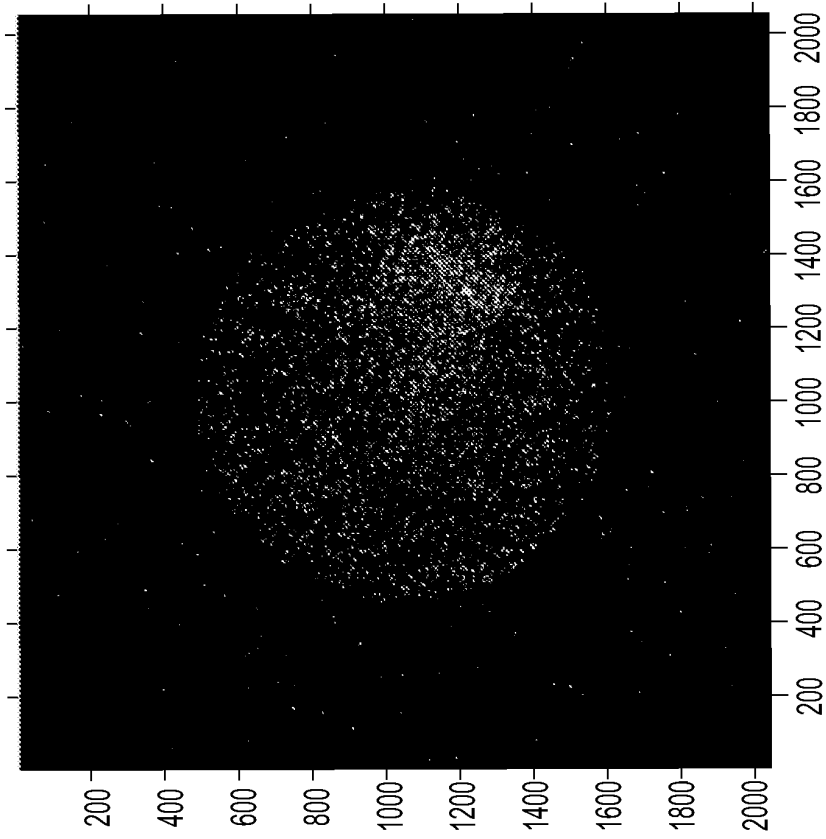


Figure 47



**Figure 50**



**Figure 49**

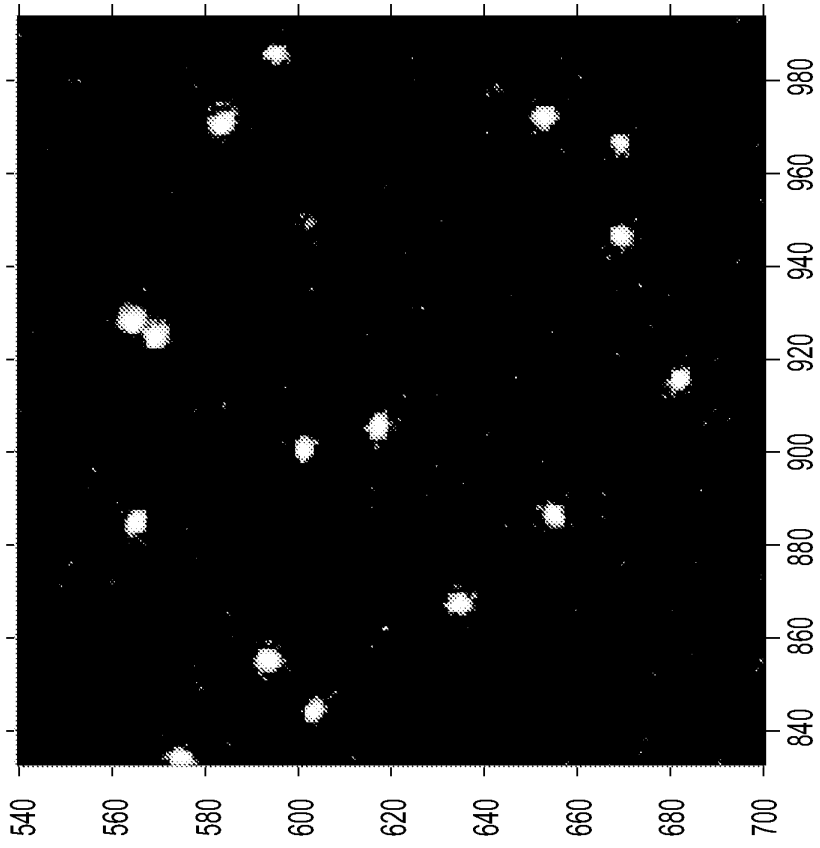


Figure 52

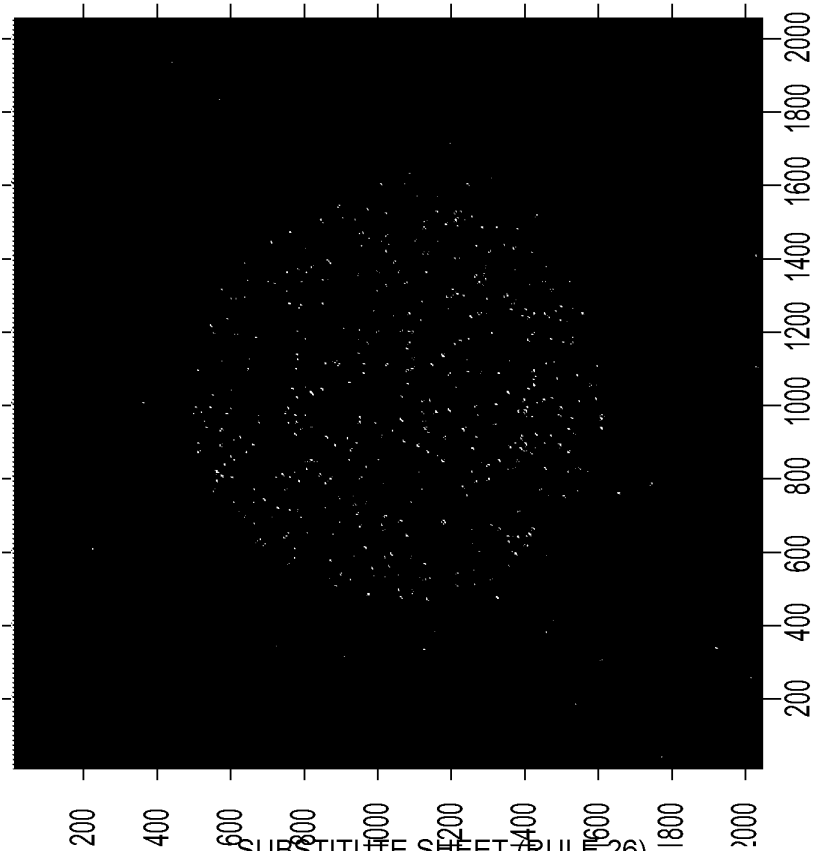


Figure 51

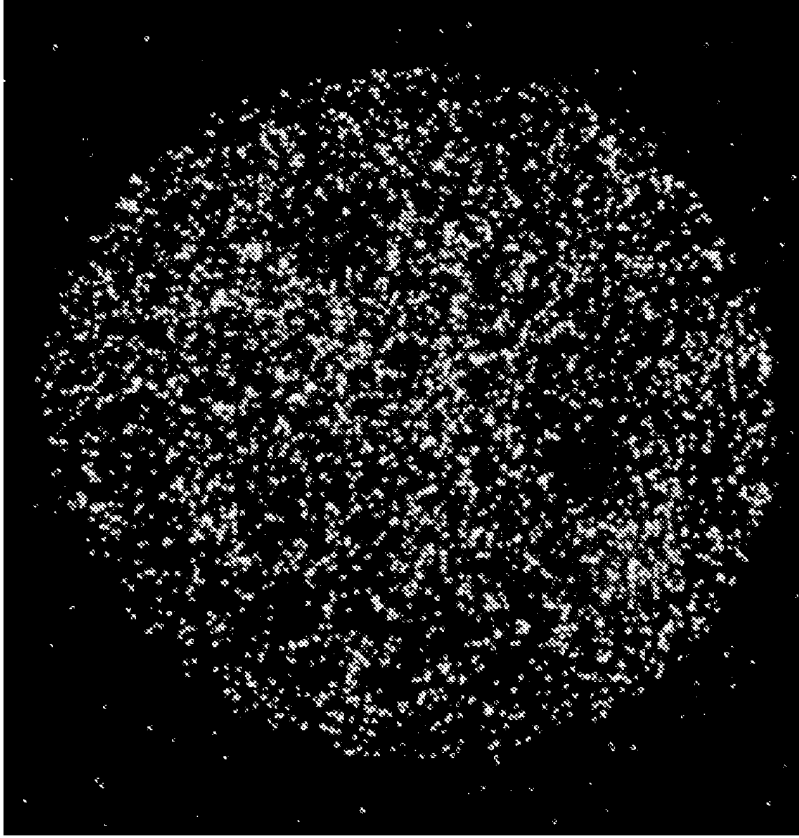


Figure 54

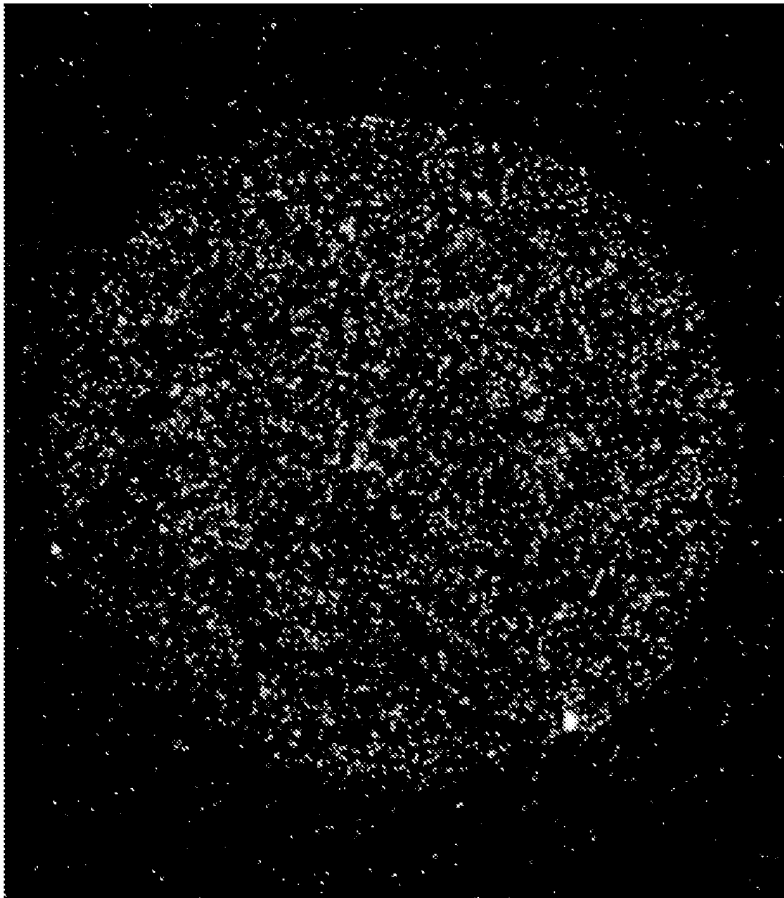


Figure 53

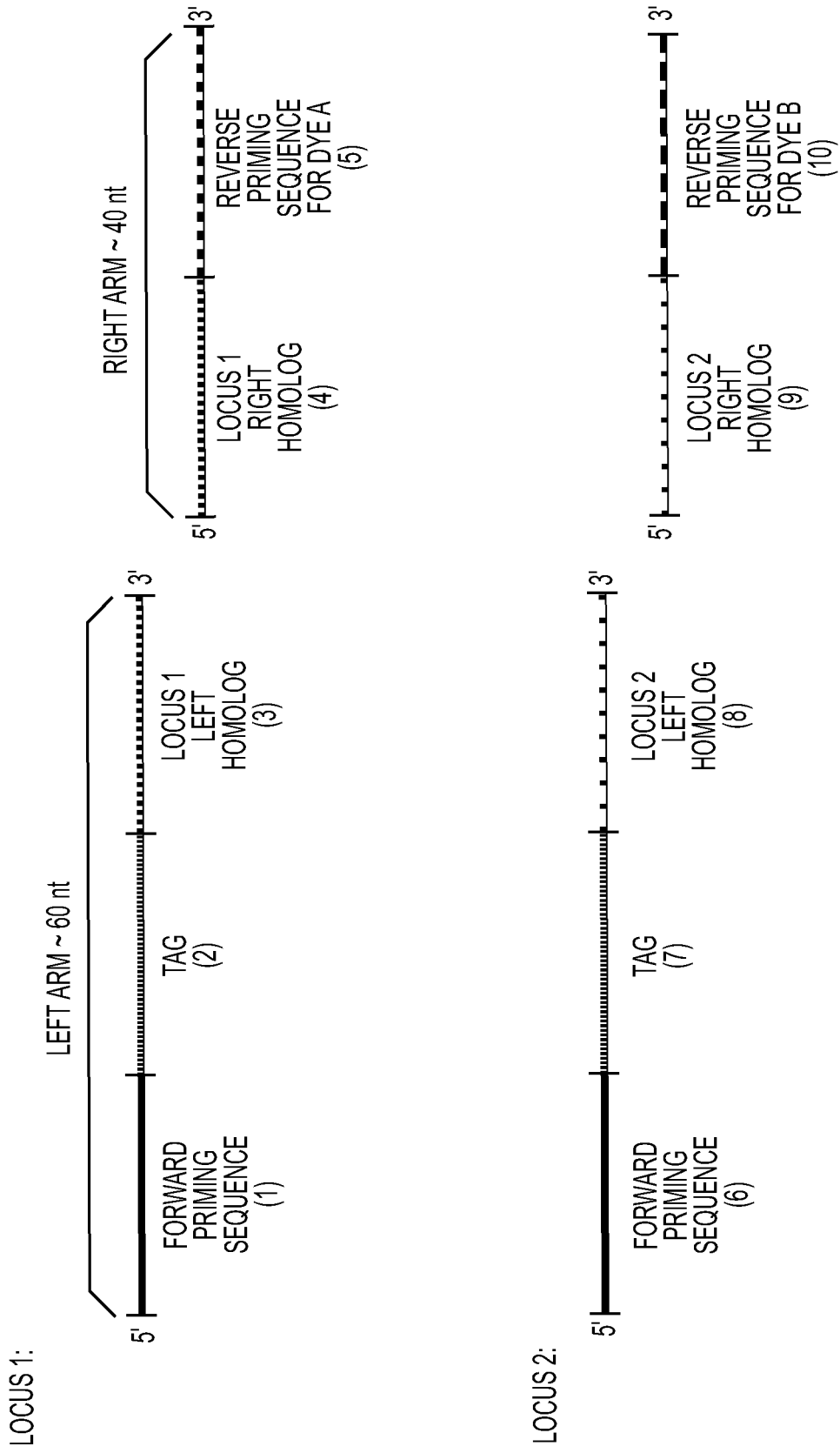


Figure 55

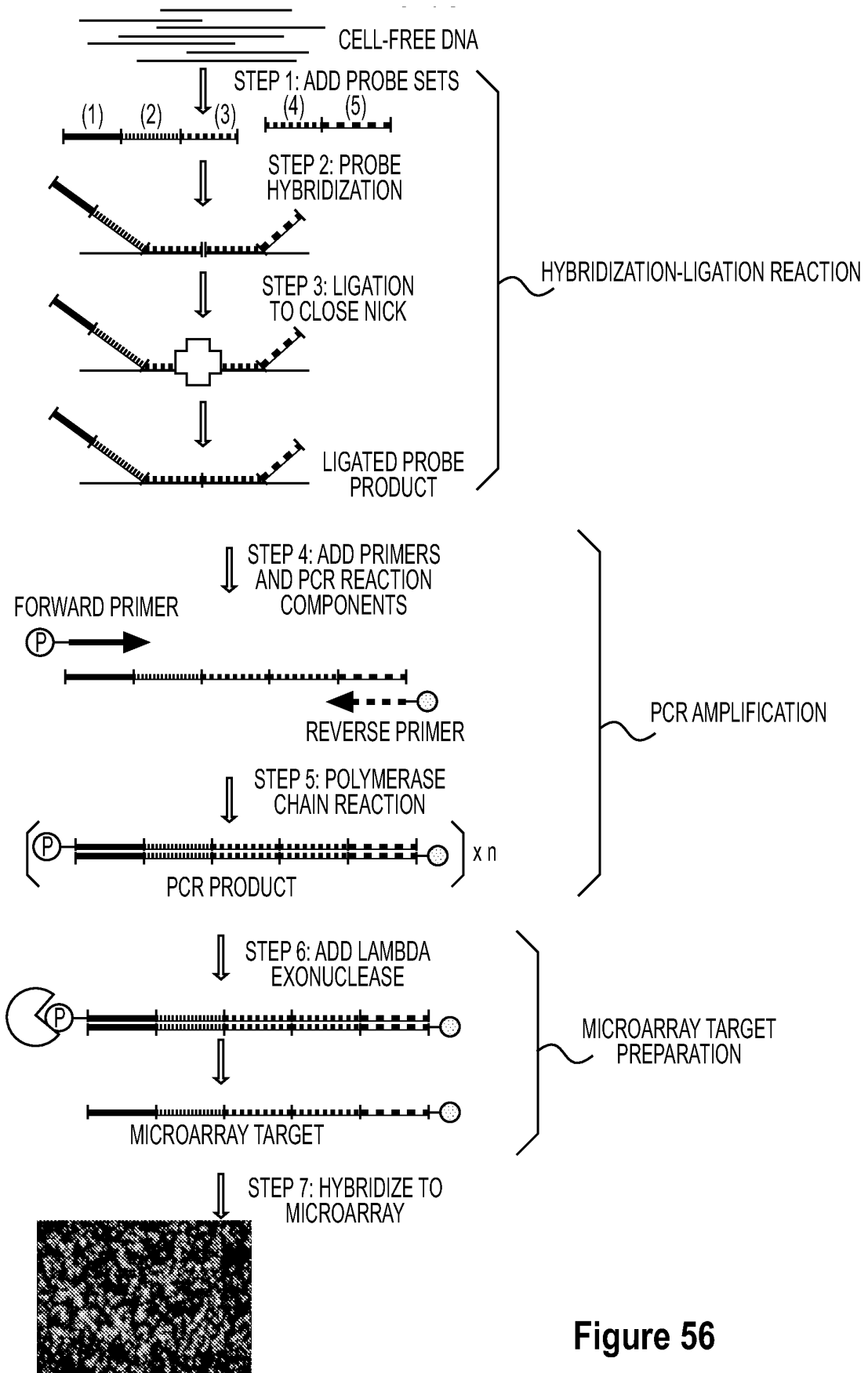


Figure 56

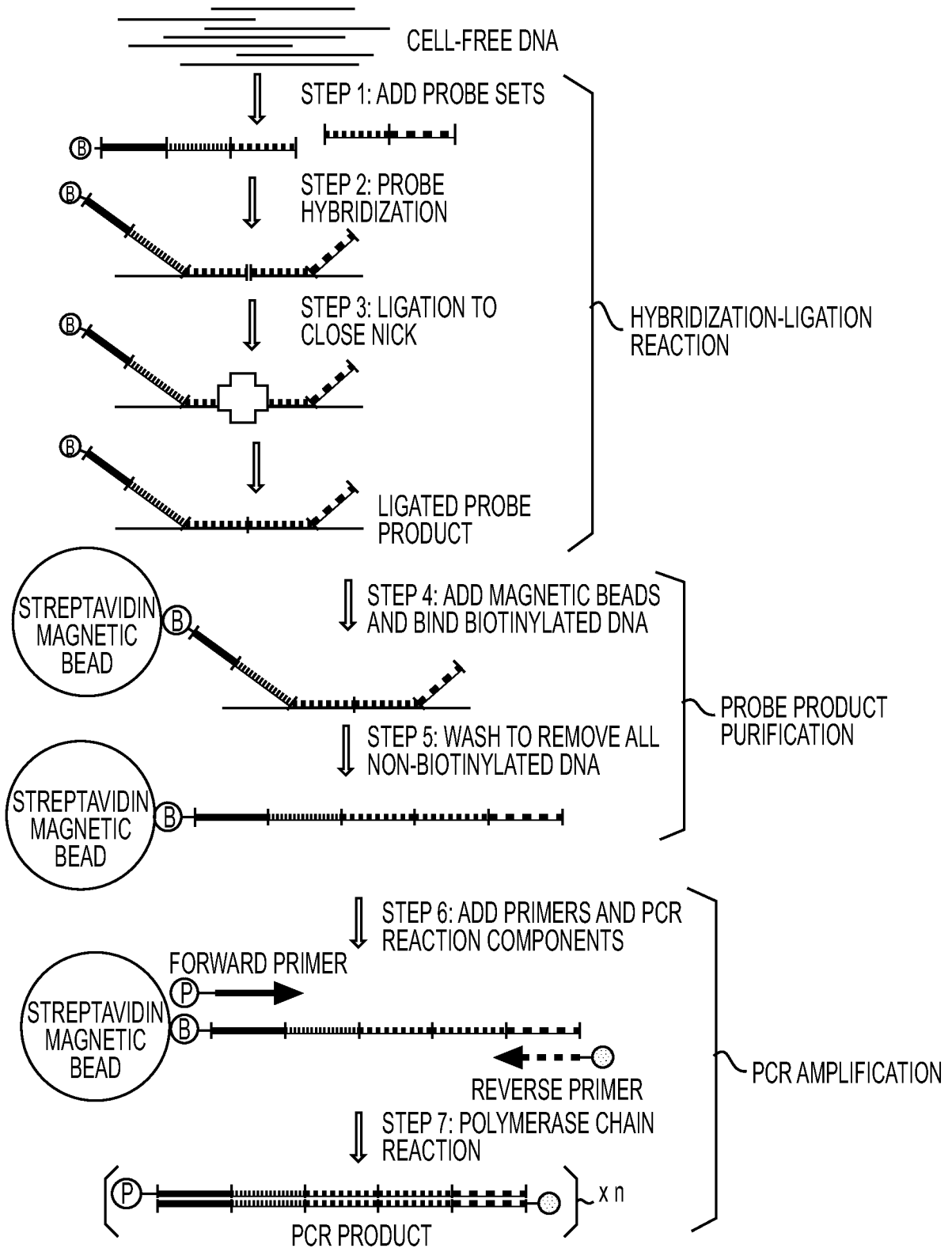


Figure 57

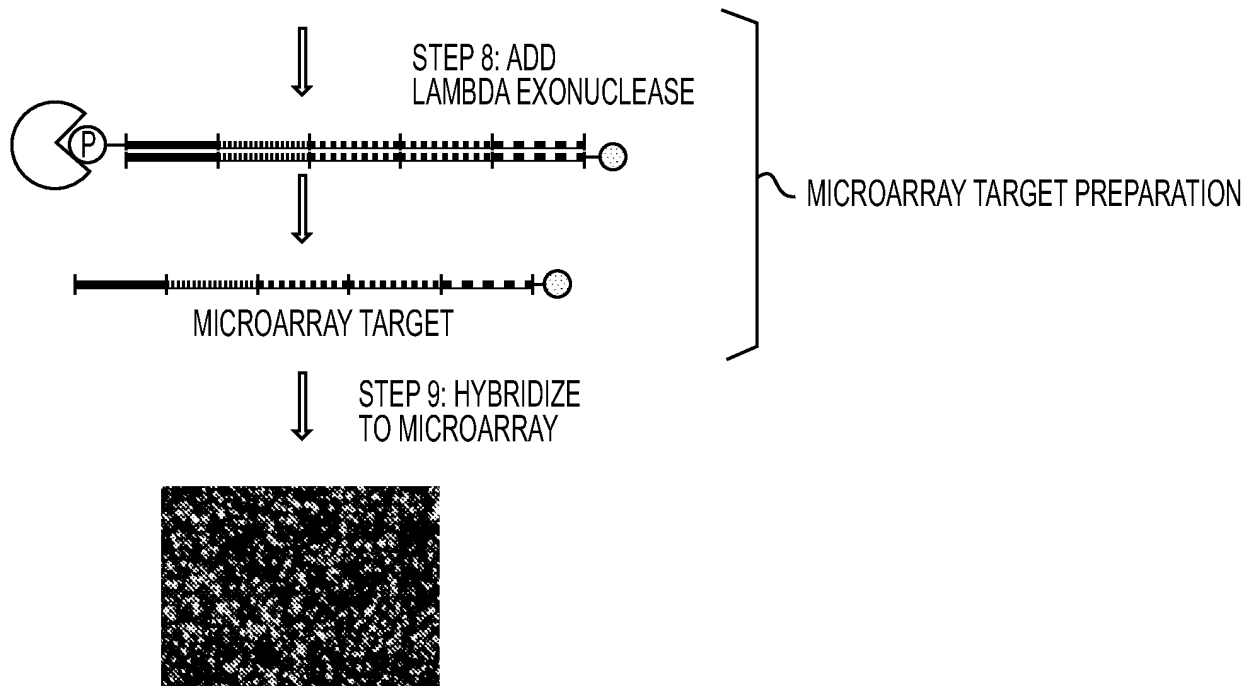


Figure 57 Continued

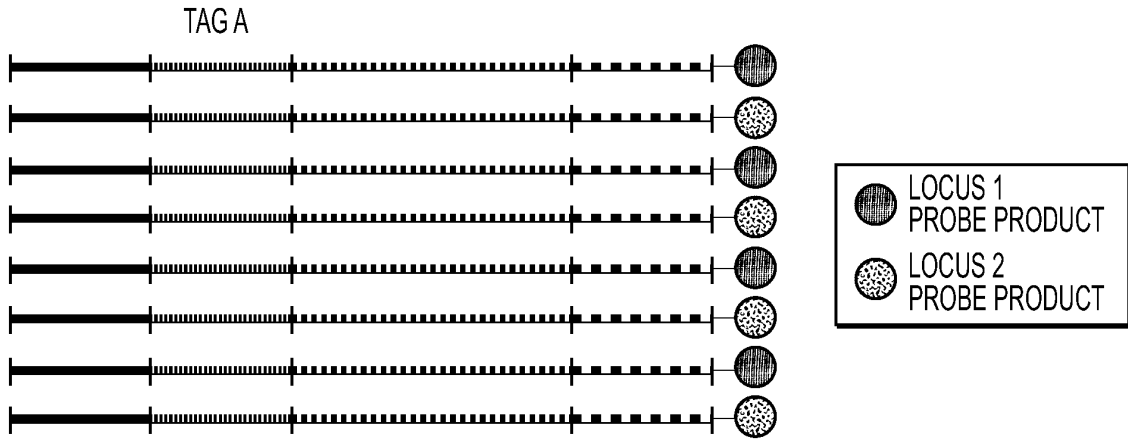


Figure 58A

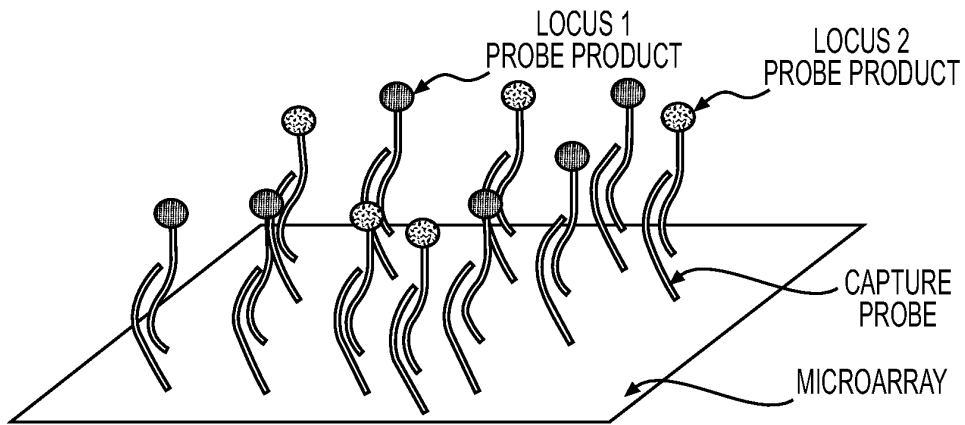


Figure 58B

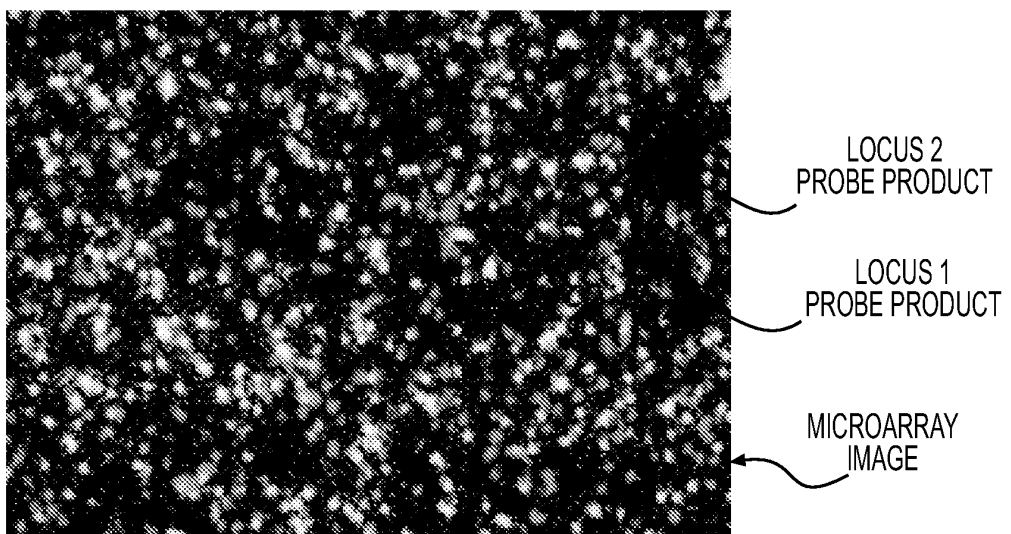


Figure 58C

SUBSTITUTE SHEET (RULE 26)

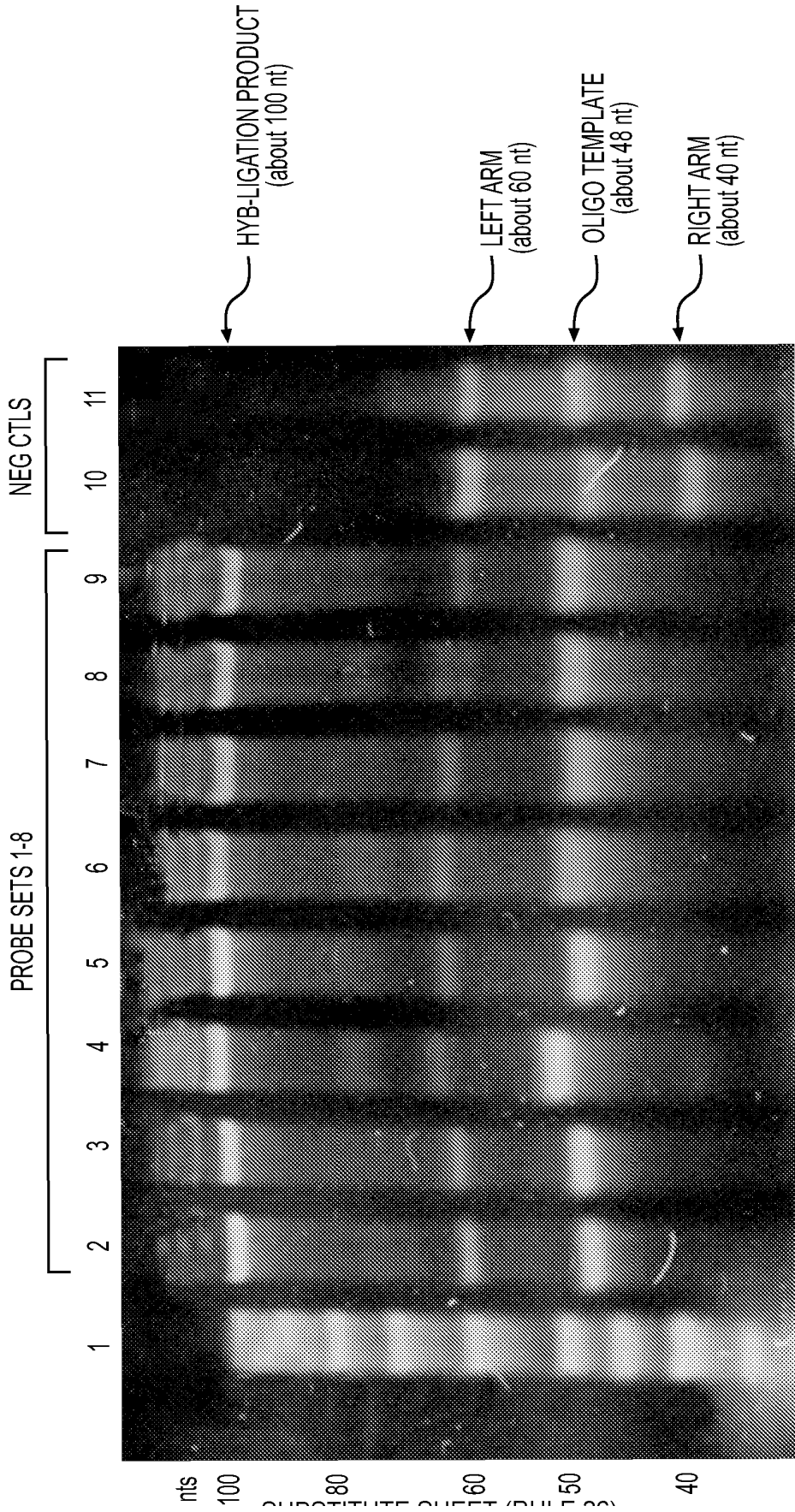
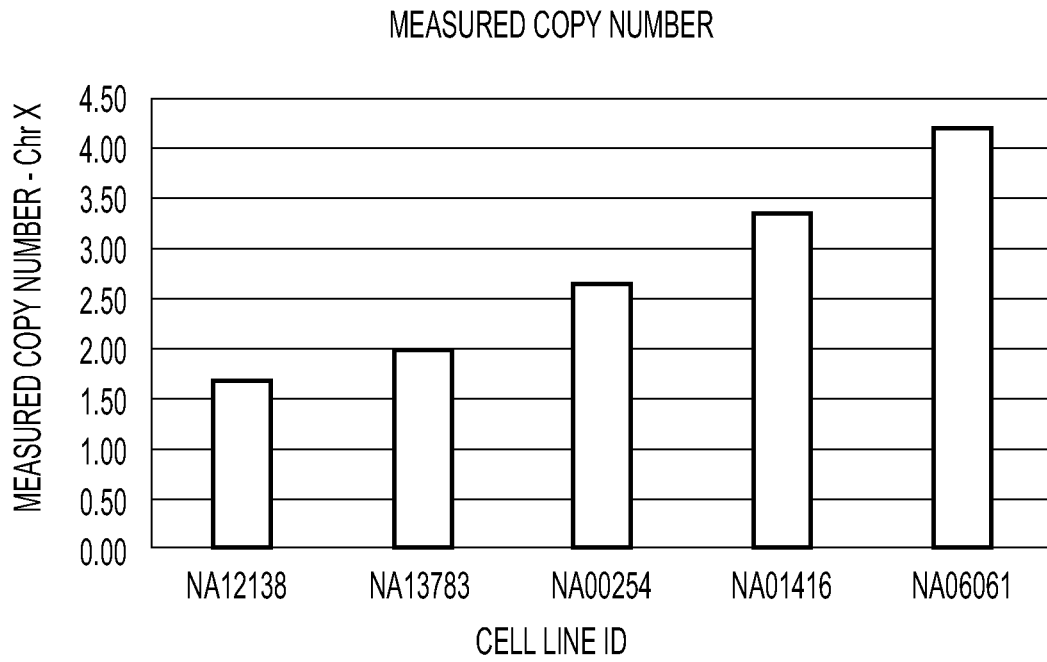
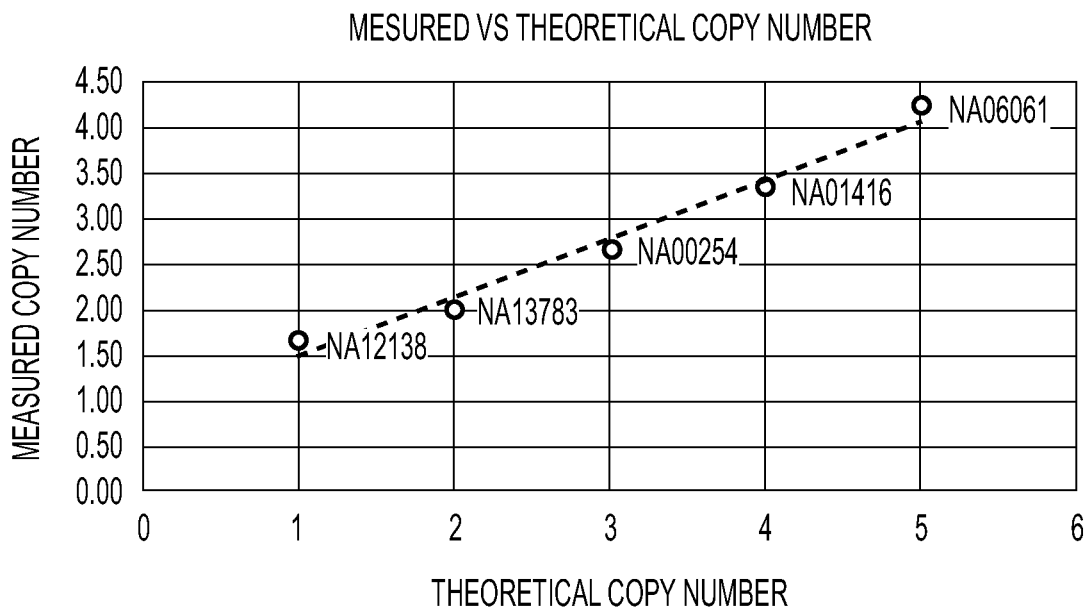


Figure 59



**Figure 60A**



**Figure 60B**

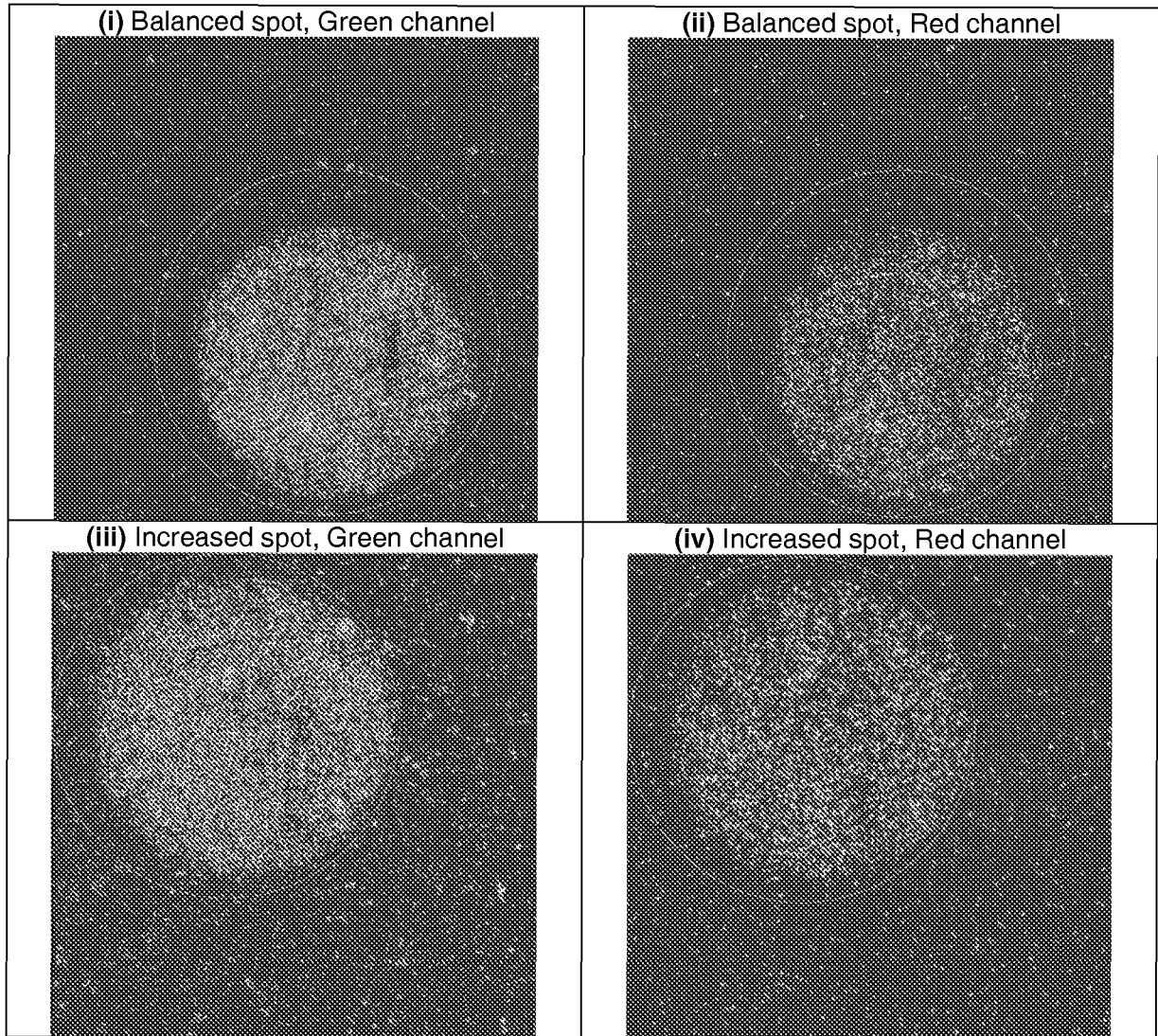


Figure 61A

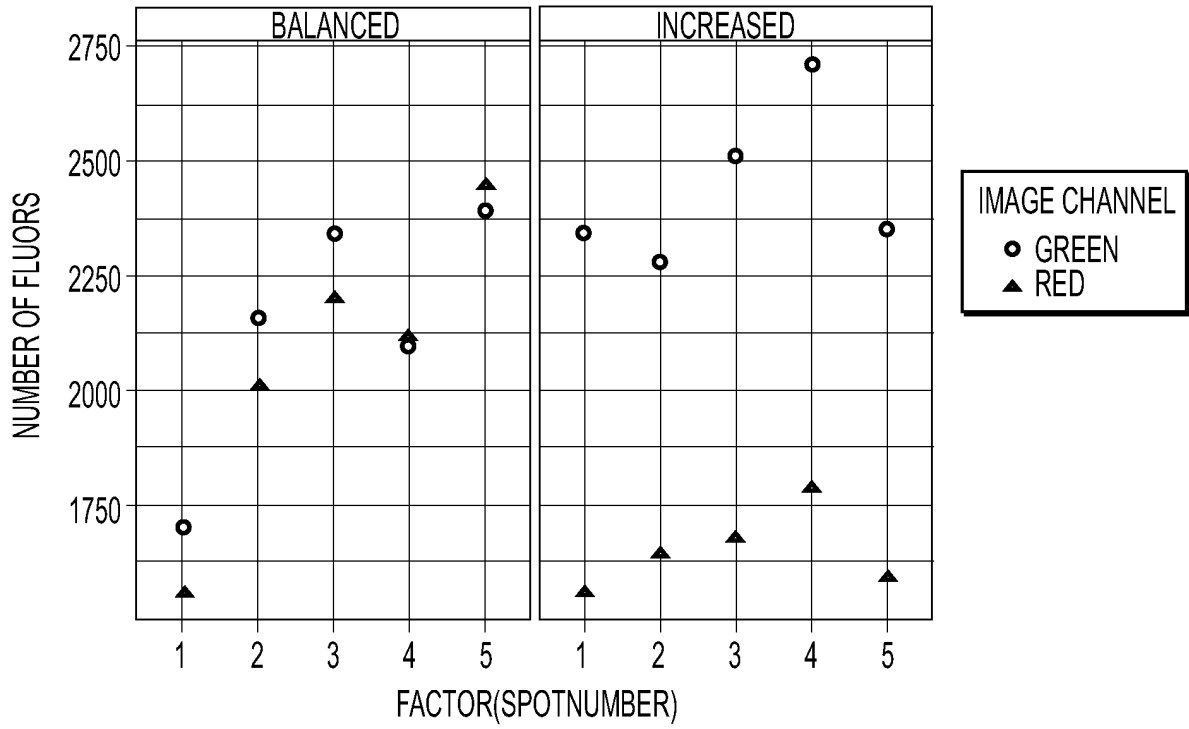


Figure 61B

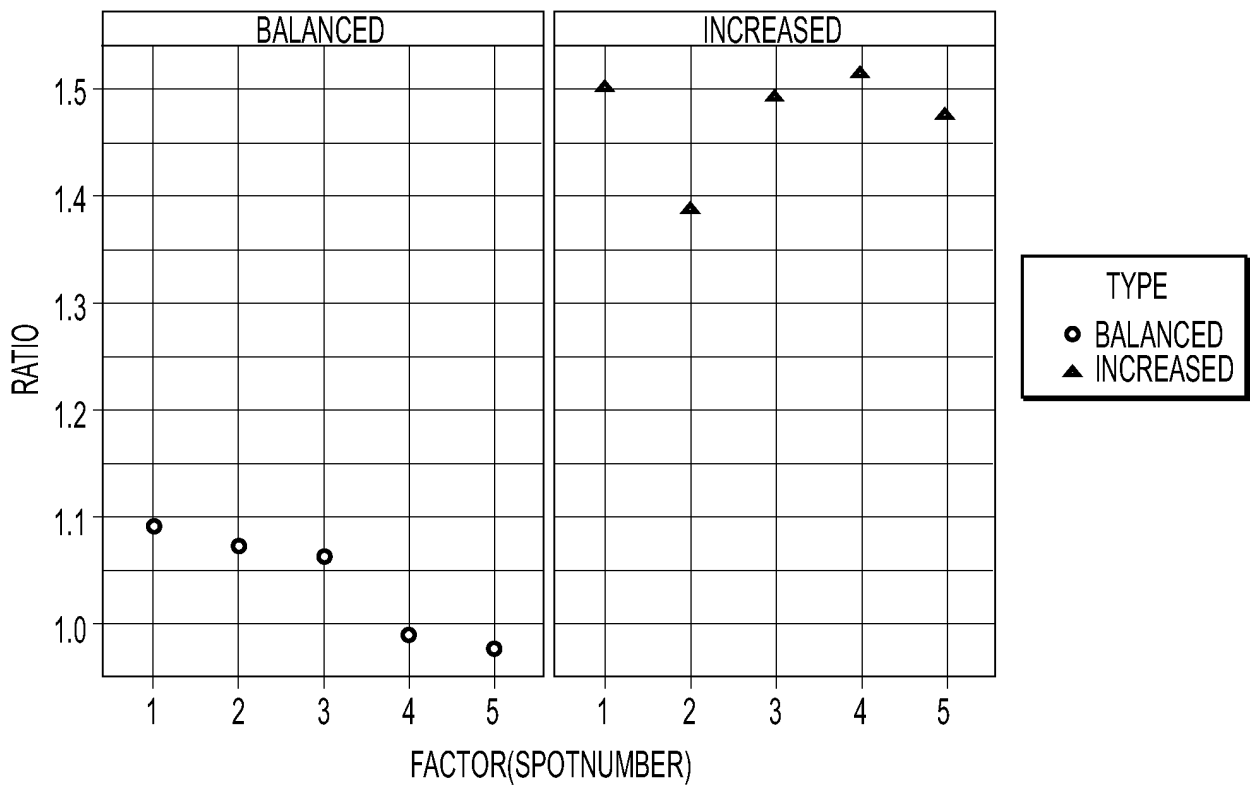


Figure 61C

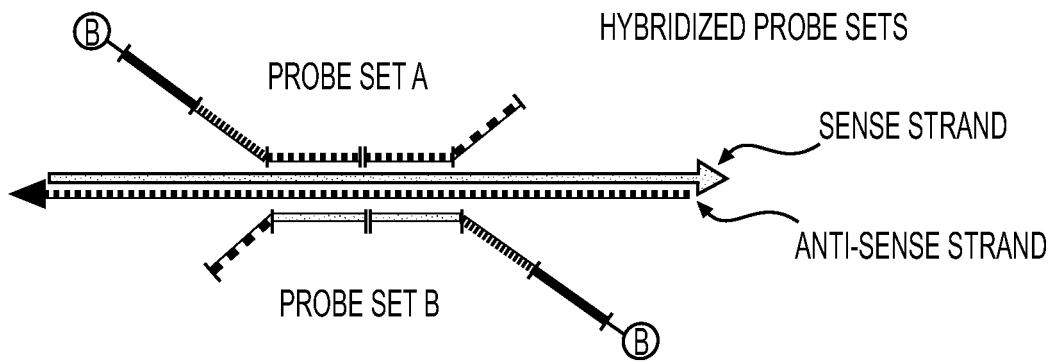
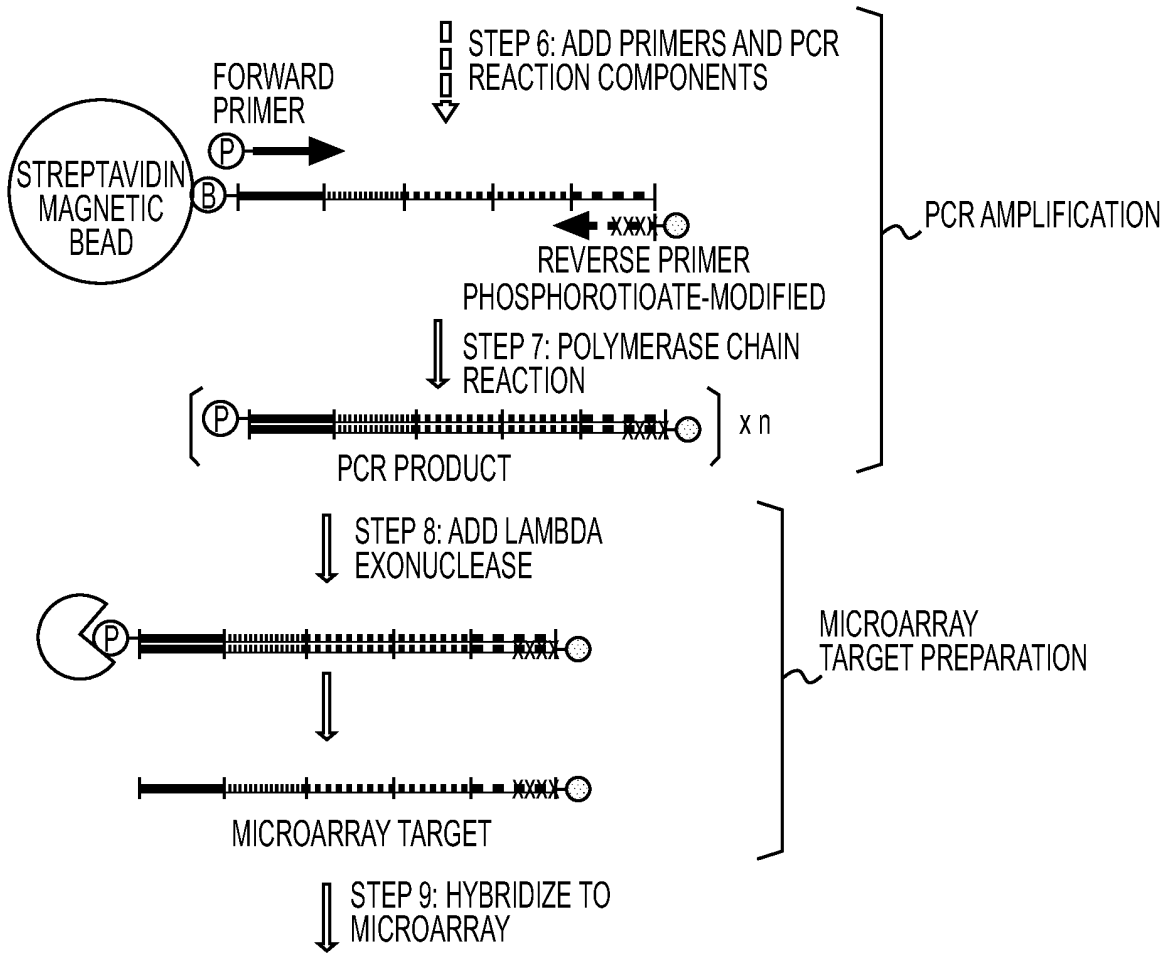
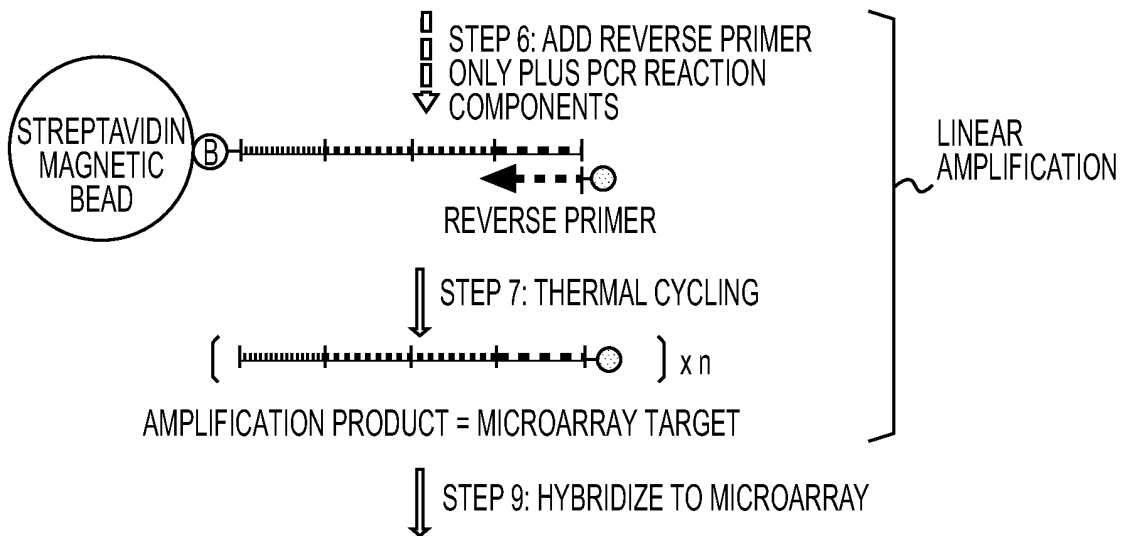


Figure 62



**Figure 63**



**Figure 64**

CYCLE 1 HYBRIDIZATION-LIGATION EVENTS

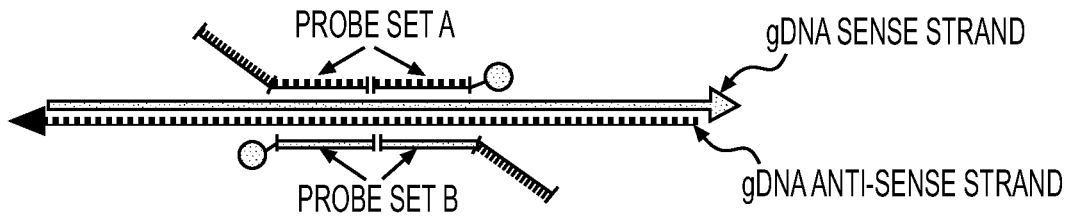


Figure 65A

CYCLE 2 HYBRIDIZATION-LIGATION EVENTS

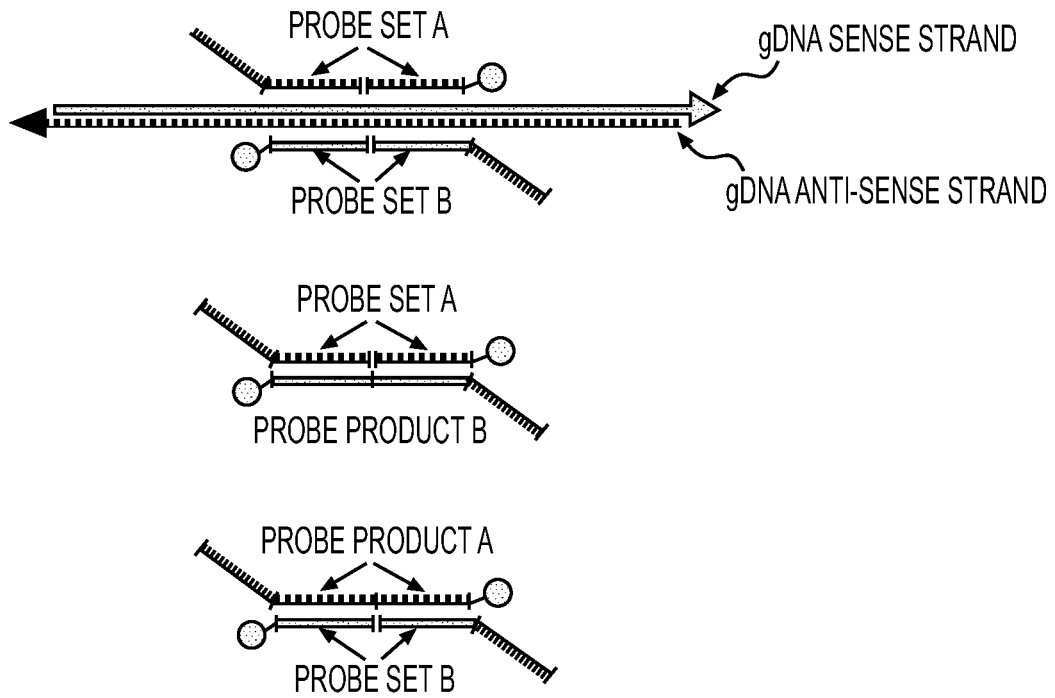
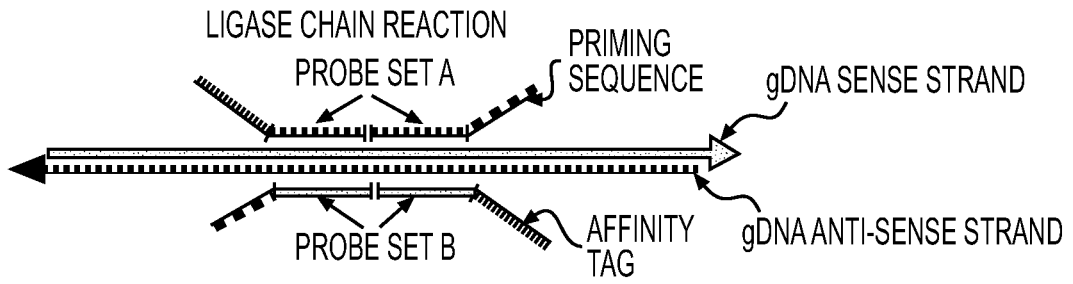
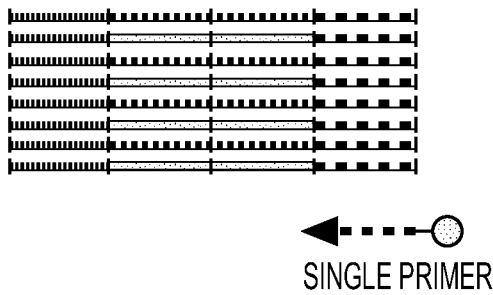


Figure 65B



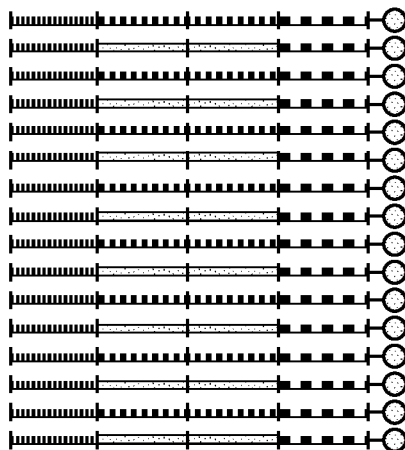
**Figure 66A**

LINEAR AMPLIFICATION AND LABELING WITH ONE PRIMER

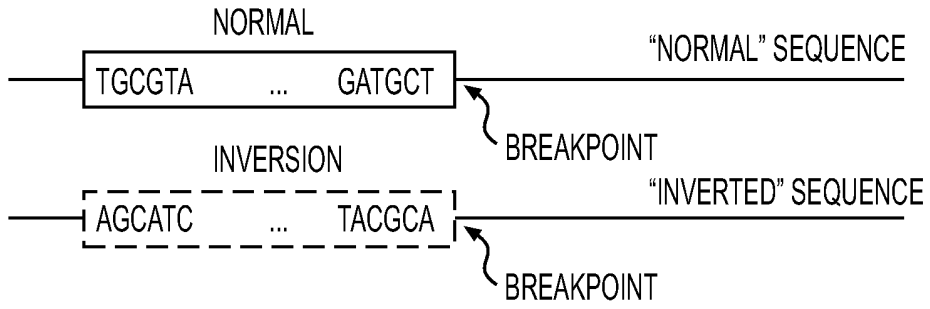


**Figure 66B**

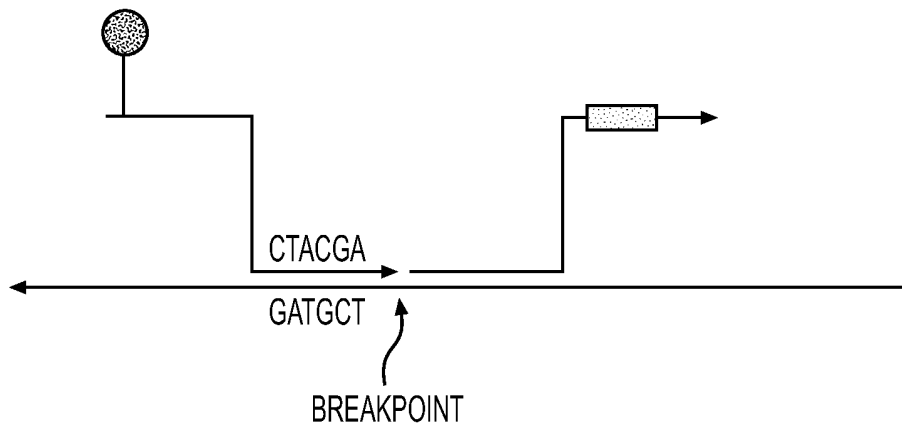
MICROARRAY TARGET



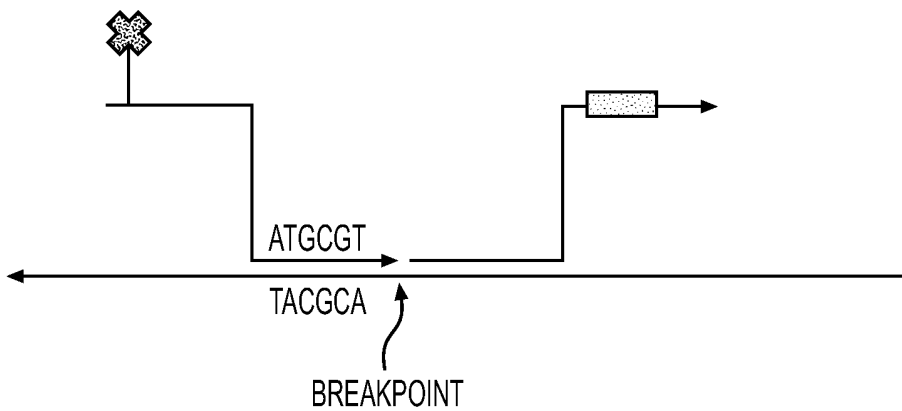
**Figure 66C**



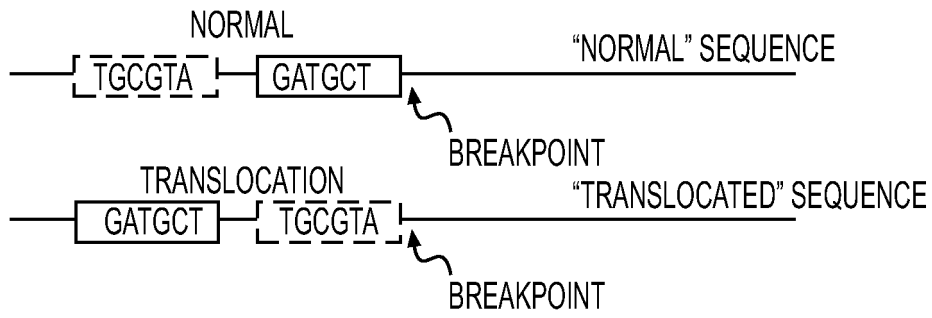
**Figure 67A**



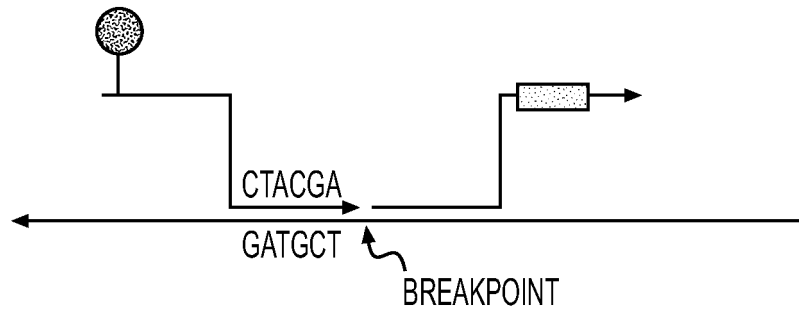
**Figure 67B**



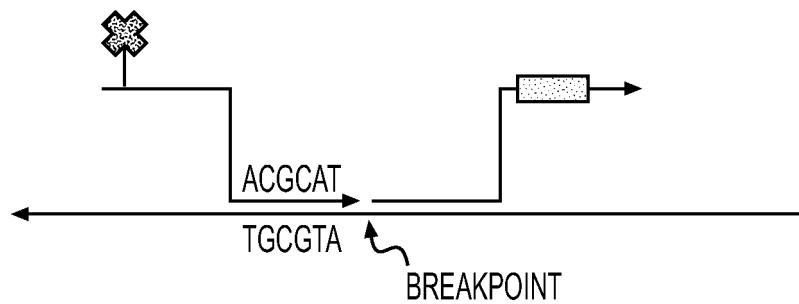
**Figure 67C**



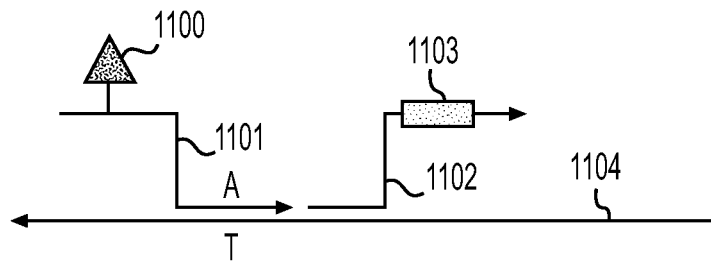
**Figure 68A**



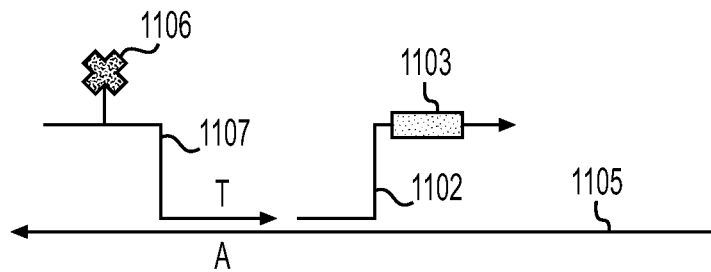
**Figure 68B**



**Figure 68C**



**Figure 69A**



**Figure 69B**

**REFERENCES CITED IN THE DESCRIPTION**

*This list of references cited by the applicant is for the reader's convenience only. It does not form part of the European patent document. Even though great care has been taken in compiling the references, errors or omissions cannot be excluded and the EPO disclaims all liability in this regard.*

**Patent documents cited in the description**

- US 2002025529 A [0035]
- WO 9714028 A [0040]
- US 20130172216 A [0041] [0093]
- WO 317535003 A [0259]
- US 61867554 B [0259]
- US 61867559 B [0259]

**Non-patent literature cited in the description**

- **KIMMEL ; OLIVER.** DNA Microarrays. Elsevier, 2006 [0004]
- **CAMPBELL.** DNA Microarray, Synthesis and Synthetic DNA. Nova Science, 2012 [0004]
- **BOWTELL ; SAMBROOK.** DNA Microarrays: Molecular Cloning Manual. Cold Spring Harbor Laboratory Press, 2003 [0004]
- **LEONE et al.** *Nucleic Acids Research*, 1998, vol. 26, 2150-2155 [0029]
- **SCHENA.** Microarrays: A Practical Approach. IRL Press, 2000 [0041]
- **BURNETTE et al.** *Proc. Natl. Acad. Sci. USA*, 2011, vol. 108, 21081-21086 [0091]

专利名称(译)	用于单分子检测的分析及其用途		
公开(公告)号	<a href="#">EP3036545A1</a>	公开(公告)日	2016-06-29
申请号	EP2014838189	申请日	2014-08-19
[标]申请(专利权)人(译)	卓异生物公司		
申请(专利权)人(译)	奇异BIO INC.		
当前申请(专利权)人(译)	奇异BIO INC.		
[标]发明人	FEHR ADRIAN NIELSEN COLLINS PATRICK JAMES HERSCHLEB JILL LYNDON JONES HYWEL BOWDEN		
发明人	FEHR, ADRIAN NIELSEN COLLINS, PATRICK JAMES HERSCHLEB, JILL LYNDON JONES, HYWEL BOWDEN		
IPC分类号	G01N33/53 C12Q1/68		
CPC分类号	C12Q1/6809 C12Q1/6825 C12Q1/6827 C12Q1/6837 C12Q2521/101 C12Q2531/137 C12Q2535/125 C12Q2545/101 C12Q2563/107 C12Q2565/102 C12Q2565/519 C12Q2565/601 C12Q2525/155 C12Q2525/161 C12Q2525/185 C12Q2533/107 C12Q2535/131 C12Q2537/143 C12Q1/6876 C12Q2600 /156 C12Q2600/158 C12Q2600/16		
代理机构(译)	MASCHIO , ANTONIO		
优先权	61/867559 2013-08-19 US 61/867554 2013-08-19 US		
其他公开文献	EP3036545B1 EP3036545A4		
外部链接	<a href="#">Espacenet</a>		

#### 摘要(译)

本发明涉及使用标记探针检测来自受试者的遗传样品中的遗传变异并计数探针中标记数的方法。