

(19)



(11)

EP 2 864 781 B1

(12)

EUROPEAN PATENT SPECIFICATION

(45) Date of publication and mention of the grant of the patent:
13.12.2017 Bulletin 2017/50

(51) Int Cl.:
G01N 33/533 ^(2006.01) **G01N 33/50** ^(2006.01)
G01N 33/58 ^(2006.01) **G01N 21/64** ^(2006.01)
B01L 3/00 ^(2006.01)

(21) Application number: **13807718.5**

(86) International application number:
PCT/DK2013/050208

(22) Date of filing: **21.06.2013**

(87) International publication number:
WO 2013/189502 (27.12.2013 Gazette 2013/52)

(54) **A METHOD AND A SYSTEM FOR QUANTITATIVE OR QUALITATIVE DETERMINATION OF A TARGET COMPONENT**

VERFAHREN UND SYSTEM ZUR QUANTITATIVEN ODER QUALITATIVEN BESTIMMUNG EINER ZIELKOMPONENTE

PROCÉDÉ ET SYSTÈME PERMETTANT LA DÉTERMINATION QUANTITATIVE OU QUALITATIVE D'UN COMPOSÉ CIBLE

(84) Designated Contracting States:
AL AT BE BG CH CY CZ DE DK EE ES FI FR GB GR HR HU IE IS IT LI LT LU LV MC MK MT NL NO PL PT RO RS SE SI SK SM TR

US-A1- 2004 043 512 US-A1- 2004 043 512

(30) Priority: **22.06.2012 DK 201270353**

(43) Date of publication of application:
29.04.2015 Bulletin 2015/18

- FENG J ET AL: "FUNCTIONALIZED EUROPIUM OXIDE NANOPARTICLES USED AS A FLUORESCENT LABEL IN AN IMMUNOASSAY FOR ATRAZINE", ANALYTICAL CHEMISTRY, AMERICAN CHEMICAL SOCIETY, US, vol. 75, no. 19, 1 October 2003 (2003-10-01), pages 5282-5286, XP001184591, ISSN: 0003-2700, DOI: 10.1021/AC034063M
- HUA KUANG ET AL: "Recent developments in analytical applications of quantum dots", TRAC, TRENDS IN ANALYTICAL CHEMISTRY, vol. 30, no. 10, 2011, pages 1620-1636, XP028310103, ISSN: 0165-9936, DOI: 10.1016/J.TRAC.2011.04.022 [retrieved on 2011-08-19]
- CHAN, M.-L. ET AL.: 'Magnetic scanometric DNA microarray detection of methyl tertiary butyl ether degrading bacteria for environmental monitoring' BIOSENSORS AND BIOELECTRONICS vol. 26, 2011, pages 2060 - 2066, XP027580117
- HENARES, T.G. ET AL.: 'Current development in microfluidic immunosensing chip' ANALYTICA CHIMICA ACTA vol. 611, 2008, pages 17 - 30, XP022495630

(73) Proprietor: **Scandinavian Micro Biodevices ApS 3520 Farum (DK)**

- (72) Inventors:
- **HELLER, Martin DK-2860 Søborg (DK)**
 - **OVERBY, Bent DK-2600 Glostrup (DK)**
 - **BAU-MADSEN, Niels Kristian DK-2900 Hellerup (DK)**

(74) Representative: **Hegner, Anette Hegner & Partners A/S Symbion Science Park Fruebjergvej 3 2100 Copenhagen Ø (DK)**

(56) References cited:
EP-A1- 2 287 611 EP-A1- 2 287 611
WO-A1-2012/032294 WO-A2-2007/092713
WO-A2-2007/092713 US-A- 4 331 337

Note: Within nine months of the publication of the mention of the grant of the European patent in the European Patent Bulletin, any person may give notice to the European Patent Office of opposition to that patent, in accordance with the Implementing Regulations. Notice of opposition shall not be deemed to have been filed until the opposition fee has been paid. (Art. 99(1) European Patent Convention).

EP 2 864 781 B1

- YANG, S.-Y. ET AL.: 'Micro flow cytometry utilizing a magnetic bead-based immunoassay for rapid virus detection' **BIOSENSORS AND BIOELECTRONICS** vol. 24, 2008, pages 855 - 862, XP025535164

Description**TECHNICAL FIELD**

[0001] The present invention relates to a method and a system for quantitative or qualitative determination of a target component in a liquid sample, in particular a biologic target component or optionally several target components in the same liquid sample.

BACKGROUND ART

[0002] A plurality of methods and devices for quantitative or qualitative determination of a target component in a liquid sample are known from the prior art. Many of these prior art methods comprise complicated or time consuming steps, such as washing steps. For many years new and improved methods have constantly been developed, and in particular methods using optical labeling and read out systems.

[0003] The use of magnetic particles with capture probes has also been explored in several methods.

[0004] A fluorimetric immunological assay with magnetic particles is described in US 4,731,337. In this document it was suggested to perform a test using plastic pearls comprising a magnetic substance and carrying antigen for an antibody to be studied in a transparent test tube. The pearls are put into the test tube together with a sample containing the antibody to be studied as well as an antibody marked with a fluorescent molecule. Upon completion of the reaction, the quantity of the marked antibody adhering to the antigen on the solid phase is measured in a fluorometer, in which both the excitation radiation is passed into the sample and the fluorescent radiation is collected to the detector through the bottom of the measurement vessel. Moreover, the fluorometer is provided with means for generating a magnetic field, and by its means the pearls are pulled against the bottom of the measurement vessel for the time of the measurement. Moreover, before the measurement, a coloring agent is added to the sample to absorb intensively at the wavelength of the excitation radiation or of the emission radiation in order to reduce interference by the excess tracer remaining in the liquid phase or by the background radiation with the measurement.

[0005] The above method has, however, never been used in practice.

[0006] WO 2010/042242 discloses for example a use of magnetic particles in combination with a fluidic device. The fluidic device disclosed herein has a main channel, wherein a first inlet fluidly connects to an upstream end of the main channel and the method comprises introduction of magnetic beads into the channel. The magnetic beads are configured to bind to a target. A magnet is applied to magnetically move the magnetic beads through various sections of the fluidic device to allow the magnetic beads to capture a target, to a washing step and other steps required for obtaining a quantification of

the target captured on the magnetic beads.

[0007] WO 2008/109675 discloses a device and method for the capture of magnetic beads in a rotary magnetic bead trap. The device allows capture, washing, elution and ejection of beads in an automated system. Analyte is eluted in a small volume in a capillary-scale fluid system compatible with LC-MS/MS analysis.

[0008] US 2010/0248258 discloses a microfluidic chip and method for rapid detection of different target proteins. The microfluidic chip utilizes antibody-conjugated magnetic beads to bind to the target proteins to form a magnetic complex, and then use the signal labeled-antibodies that can recognize the magnetic complex. The method comprises purifying the magnetic complex by the micro-magnetic field on biochip, and introducing the purified magnetic complex into the fluorescent detection area on the chip to detect the amount of the target protein in the purified complex immediately.

[0009] US 4,347,312 discloses a method for detecting the presence of antibiotics in milk which comprises the steps of: (a) contacting a solid matrix having attached thereto a purified immobilized antibody with a volume of milk and an enzyme-labeled antibiotic, the antibody being specific to the antibiotic; (b) separating the matrix from the milk and rinsing the matrix with water to remove excess milk and enzyme-labeled antibiotic; (c) contacting the rinsed matrix with a substrate, the substrate in the presence of the enzyme-labeled antibiotic exhibiting a color change the amount of which is quantitatively related to the amount of enzyme-labeled antibiotic; and (d) measuring the amount of antibiotic present in the milk by comparing the color change in the substrate with a standard. Also provided is a method for producing purified antibodies for use in the foregoing detection method by: (a) covalently conjugating an antibiotic having a lactam-ring in the molecule to a protein capable of binding thereto through the lactam-ring; (b) injecting into a host animal capable of raising antibodies specific to the antibiotic the conjugate obtained in step (a) so as to raise the specific antibodies; (c) covalently conjugating the same antibiotic in step (a) to a second protein capable of binding thereto through the lactam-ring and different than the protein used in step (a) to form a second conjugate; (d) covalently binding the second conjugate to a solid matrix to form an affinity matrix for purifying the antibodies; (e) isolating and purifying the specific antibodies raised in step (b) by contacting the host animal serum with the affinity matrix; and (f) recovering the specific antibodies in a pure form.

[0010] WO2007/092713 discloses a system for detection of cancer cells. The system comprises a microfluidic cassette for sample preparation; continuous-flow, magnetic-bead assisted cell sorting and cytometry; cell lysis; nucleic acid isolation and amplification, hybridization, quantification, and analysis. In an embodiment the cell sorting is based on the selective binding of magnetic beads coated with an MCAP antibody to exfoliated precancerous and cancerous cells contained in saliva. The bead-labeled precancerous and cancerous cells are then

separated from other saliva components using a magnetic field. Both labeled and unlabeled cells can be counted using integrated detectors of several types, including cell counters based on impedance measurements, and cytometers based on Coulter particle counter principles. In an alternative embodiment optical methods may be used for read out and one MACP is used to bind with the functionalized magnetic bead while other MACP may be used to attach a label.

[0011] WO2012/032294 discloses a microfluidic based assay system, comprising a disposable assay cartridge and associated reading device. The cartridge comprises one or more microfluidic channels disposed therein and comprising a binding agent disposed within said channel(s) for binding any of said analyte within the sample; a sample port for introducing said fluid sample into the cartridge; at least one fluid input port for allowing one or more fluids to be introduced to the cartridge from an associated reader device and transported through the microfluidic channel(s); and a fluid outlet sink for removing fluid from said channel(s). The binding agent may be a magnetic particle. The bound analyte may be detected directly or it may be coupled to a detection agent which is able to bind to a different portion of the analyte to which the first binding agent binds.

[0012] Feng J et al: "FUNCTIONALIZED EUROPIUM OXIDE NANOPARTICLES USED AS AFLUORESCENT LAEL IN AN IMMUNOASSAY FOR ATRAZINE", Analytical chemistry, American chemical society, US, vol. 75, no. 19, 1 October 2003, pages 5282-5286, XP001184591 discloses a competitive assay performed in a test tube. The target is Atrazine and the assay uses a marker, a monoclonal anti-atrazine antibody and magnetic beads. The marker has a reaction site for the monoclonal anti-atrazine antibody. The magnetic beads have reaction sites for another moiety of the monoclonal anti-atrazine antibody. After end reaction the magnetic particles are removed from the solution and optical examination is performed on the solution after the magnetic particles have been moved.

[0013] US2004/043512 discloses a self-calibrated, magnetic binding assay for detecting the presence or quantity of an analyte residing in a test sample. The magnetic binding assay includes detection probes capable of generating a detection signal and calibration probes capable of generating calibration signal. The assay is performed of a lateral flow device, comprising a sampling pad of porous material, a porous membrane, a conjugate pad and a wicking pad. Between the conjugate pad and the wicking pad the device has a detection zone where a magnetic device captures fluorescent magnetic particle. In use sample, fluorescent non-magnetic particles and fluorescent magnetic particle are added to the conjugate pad and the sample is added to the sampling pad and passes to the conjugate pad, where the elements react to form conjugates and the conjugates migrates through the porous membrane towards the wicking pad such that the fluorescent magnetic particles are captured

at the detection zone 31.

[0014] EP 2 287 611 discloses a detecting method for detection target substances within samples using magnet enveloping dielectric particles. It is mentioned that sandwich type assays and competitive type assays may be performed by the detecting method. However it is not described how such competitive assay is performed. The detection method is performed in a sample cell with a metal film and magnetic property imparted binding substances and labelling binding substances are mixes into the liquid sample in the sample cell. The labels are excited using evanescent field technique.

DISCLOSURE OF INVENTION

[0015] An object of the present invention is to provide a new method for quantitative or qualitative determination of a target component in a liquid sample, which method is simple and fast and where it is possible to perform determinations of two or more target components simultaneously.

[0016] An object of the present invention is further to provide a system for performing quantitative or qualitative determination of a target component in a liquid sample where the cost for each determination is relatively low.

[0017] In an embodiment of the invention it is further an object to provide a method which does not require time consuming washing steps and preferably where it is possible to perform a determination relatively fast e.g. in a few minutes.

[0018] These objects have been achieved by the present invention and embodiments hereof as defined in the claims and described below.

[0019] The invention has shown to provide a completely new approach for quantitative or qualitative determination of a target component in a liquid.

[0020] Further it has been found that very good and accurate results can be obtained in a fast and simple way.

[0021] The invention is defined in the claims.

[0022] The method of the invention for quantitative or qualitative determination of a target component in a liquid sample, comprises

- providing a plurality of magnetic particles comprising one or more capture sites for the target component on their respective surfaces;
- providing a plurality of fluorophores configured to bind to the capture sites of the magnetic particles;
- arranging said fluorophores and said magnetic particles at a distance from each other in a flow channel of a micro fluidic device;
- feeding the liquid sample into said flow channel and mixing it with said fluorophores and said magnetic particles; and

- at least temporally immobilizing the magnetic particles adjacent to a transparent window of the flow channel using a magnet, emitting exciting electromagnetic beam(s) towards the immobilized magnetic particles, reading signals emitted from fluorophores captured by the immobilized magnetic particles and performing a quantitative or qualitative determination of the target component based on the read signal.

[0023] The method of the invention is highly suitable for qualitative determination of one or more target components and it has been found that the method can provide highly accurate results. However, the method of the invention has also shown to be very suitable for qualitative determinations e.g. for screening purposes. Examples of this will be described further below.

[0024] The "method." is also referred to by the term "test" and a liquid which is subjected to the method of the invention is tested/subjected to a test.

[0025] The term "at least temporally immobilizing the magnetic particles adjacent to the transparent window" should be taken to mean that the magnetic particles should be immobilized for a sufficient time to excite possible fluorophores captured on the magnetic particles and read signals emitted from such fluorophores. This will be further described below.

[0026] The liquid sample, the fluorophores and the magnetic particles are fed into the flow channel of the micro fluidic device, such that they are in contact with each other. In an embodiment two or all of the liquid sample, the fluorophores and the magnetic particles are brought into contact before being fed into the liquid channel. In an embodiment the liquid sample, the fluorophores and the magnetic particles are brought into contact within the liquid channel

[0027] The transparent window is for example in the form of a transparent wall section of the flow channel.

[0028] By performing the test using a micro fluid device, the method becomes very fast and only a small amount of sample is required.

[0029] Heretofore when performing tests using magnetic particle for capturing marked components, it has been an ordinary requirement that some kind of washing was required or at least a masking of false positive was required in order to obtain a useful determination. By using micro fluidic device for performing the test it has surprisingly been found that washing is not required and not even desired. In fact it is preferred that after the magnetic particles are immobilized, no further liquid should be added and in a preferred embodiment the liquid in the flow channel is at standstill, meaning that there is no flow and no turbulence within the flow channel. Further it is desired that no light absorbing elements are added beyond what is inherently in the sample. In an embodiment the sample comprises no added light absorbing elements beyond the fluorophores and the magnetic particles and what is inherent in the liquid sample. In an embodiment the sam-

ple comprises no elements absorbing light emitted by the fluorophores beyond the fluorophores and the magnetic particles.

[0030] The method has shown to give surprisingly reliable results even while determining two or more target components simultaneously.

[0031] Preferred micro fluidic devices will be described further below.

[0032] The term "liquid sample" means any liquid containing sample including liquid sample comprising solid parts, such as dispersions and suspensions. The sample comprises liquid at the time of performing the method.

[0033] In principle any liquid sample can be applied, including but not limited to liquid samples comprising particles, such as dispersed particles. The liquid sample is in one embodiment crushed food or tissue optionally blended with water or it may be an extract thereof. Thus, the method of the invention can for example be applied for performing quantitative and/or qualitative tests on tissue, vegetables, meat and etc.

[0034] In an embodiment the liquid sample comprises human or animal faeces e.g. in an aqueous suspension.

[0035] In an embodiment the liquid sample comprises waste water or water from a nature source e.g. a lake or a river.

[0036] The liquid sample should preferably have a sufficiently low viscosity for being mixed with the fluorophores and the magnetic particles preferably such as to allow possible present target components to bind to the magnetic particles. If the viscosity is too high, the sample may be diluted with liquid, such as water prior to testing. In an embodiment of the invention the liquid sample is tested in several dilutions and e.g. in undiluted condition for improving the accuracy of the determination.

[0037] In an embodiment the liquid sample comprises a biological fluid or a fraction of a biological fluid. Examples of such biological fluids include human or animal or vegetable fluids, such as blood, saliva, urine, milk, cytosol (intracellular fluid), interstitial fluid (tissue fluid) and/or one or more fractions and/or mixtures thereof.

[0038] The term "a target component" means one or more molecules of a specific type of components. The term "two or more or several target components" means two or more or several different types of target components"

[0039] A type of components comprises components which can be captured by a specific capture site on the magnetic particles. The components included in a type of components can be identical components or it can be components with a certain similarity including that they can be captured by a specific capture site on the magnetic particles.

[0040] In the following the term "target component" is for simplification mainly used in singular, but it should also include the plural version of the term "target components" unless otherwise specified.

[0041] The term "target component" and "target analytes" are used interchangeably.

[0042] The target component can in principle be any kind of target component which can be determined in a binding assay. The skilled person can in a simple manner use knowledge from other types of binding assays to select suitable target components and corresponding capture sites to be provided on the magnetic particles.

[0043] In the following it should be understood that the method for quantitative and/or qualitative determination can be performed on one or more target components simultaneously, and unless otherwise specified the singular term 'target component' should be interpreted to also include the plural term 'target components'.

[0044] In an embodiment the target component is a biomolecule, such as a single organic molecule or a structure of organic molecules e.g. an organic organism. Since there are high needs in the industry e.g. the health care industry, the food industry, the method of the invention is highly suitable for use in quantitative and/or qualitative determinations of biomolecules, in particular because the method of the invention is both very fast and highly reliable.

[0045] In an embodiment of the invention, the target component may for example be a mutant variant of a molecule or an organic organism, such as a microorganism.

[0046] In an embodiment, the target component is or comprises a microorganism such as at least one of bacterial, viral or fungal pathogens, e.g. E-coli E. coli, Citrobacter spp, Aeromonas spp., Pasteurella spp., non-serogroup DI Salmonella, Camphylobacter Staphylococcus spp and combinations thereof.

[0047] In an embodiment, the target component is or comprises a cell, such as a blood cell, a stem cell or a tumor cell.

[0048] In an embodiment, the target component is or comprises proteins, nucleotides, carbohydrates, or lipids, in particular an enzyme, an antigen or an antibody.

[0049] In an embodiment the target component is or comprises a "happen". A hapten is a small molecule that can elicit an immune response only when attached to a large carrier such as a protein; the carrier may be one that does not elicit an immune response by itself. The hapten may for example be a steroid, a hormone, an antibiotic or an inorganic constituent.

[0050] The skilled person will realize that the target component can be any kind of component for which a capture site can be provided.

[0051] Target components and corresponding capture sites are well known in the art. Also it is well known to immobilize such capture sites on a surface such as magnetic particles.

[0052] Examples of capture sites and magnetic particles comprising such capture sites for microorganism target component can for example be found in WO2012016107.

[0053] The capture sites are selected in relation to at least one target component, such that the capture sites bind to at least one target component.

[0054] In an embodiment of the method of the invention, the magnetic particles are coated magnetic particles comprising a coating comprising the capture sites, wherein the capture sites are selected to be capture sites for the target component, the coating for example comprises the capture sites in the form of antigen, antibody, avidine, biotin or Goat anti-Mouse IgG.

[0055] In an embodiment the capture sites are specific for the target component.

[0056] If there are two or more target components there may be several groups of capture sites or there may be one type of capture sites that are capture sites for all target components.

[0057] In an embodiment where there are two or more target components, the capture sites are specific for the two or more target components e.g. for a group of similar but not identical target components.

[0058] In an embodiment of the invention, the capture sites are specific for a group of components comprising one or more target components.

[0059] In an embodiment the capture sites are for example binding sites for protein, the protein content can thereby be determined. In an embodiment the capture sites are binding sites for a pre-selected type or group of proteins.

[0060] In an embodiment the binding sites are binding sites for haptens such as small organic molecules e.g. steroid hormones, antibiotics or even other hapten molecules of other origin.

[0061] The magnetic particles may in principle have any size which is suitable for handling in the micro fluidic device.

[0062] The use of magnetic particle technology in quantitative and qualitative biological tests, particularly antibody-coated magnetic beads and immunomagnetic beads have become widely used and magnetic particles for such test are commercially available in many forms.

[0063] Methods for constructing immunomagnetic particles are generally known in the art (e.g. Safarik, I. and Safarikova, M. "Magnetic techniques for the isolation and purification of proteins and peptides.: BioMagn. Res. Technol. 2 (2004)).

[0064] The magnetic particles are preferably of micro or nano size. Preferably the magnetic particles have an average size of up to about 50 μm , more preferably up to about 25 μm , such as from about 1 to about 20 μm .

[0065] The magnetic particles may be spherical or non-spherical. Some examples of magnetic particles include Cortex Megacell™-Streptavidin magnetic particles, Cortex Megabeads™-Streptavidin CM3454 (8.8 μm particle size and coated with magnetizable polystyrene/iron oxide particles), Cortex Megabeads™-Streptavidin CTM-C M019 (15.6 μm particle size and coated with polystyrene copolymer/iron oxide particles), Dynabeads™ M-280-Streptavidin (3-4 μm particle size), and Genpoint BugTrap™ magnetic beads.

[0066] Other examples of suitable magnetic particles are the magnetic particles available from Spherotech,

Inc. US. Ademtech, France including for example smaller size magnetic beads size of 200-500 nm, i.e. functionalized with streptavidin, protein A or/and G plus a number of different antibodies. Product 03152 MasterBeads StreptAvidin (Mean Diameter: ~500 nm); product 03231 Bio-Ademeads StreptAvidin plus (Mean Diameter: ~300 nm); product 03221 Bio-Ademeads streptavidin plus product (Mean Diameter: ~200 nm); 02650 Active-Masterbeads (Mean Diameter: ~500 nm) for direct protein conjugation.

[0067] Banglabs Inc, US, BM549 BioMag® Goat anti-Mouse IgG (Mean Diameter: ~1.5 μm); BM551/10272 BioMag® Streptavidin (Mean Diameter: ~1.5 μm); BM553/9750 BioMag® Protein G (Mean Diameter: ~1.5 μm); PMS3N/10098 ProMag™ 3 Series-Streptavidin (Mean Diameter: ~3.28 μm); CM01N COMPEL™ Magnetic Streptavidin modified (Mean Diameter: ~8 μm).

[0068] Fluorophores are well known in the art and are widely used within the technology of quantitative and qualitative assays.

[0069] A fluorophore (also called a fluorochrome or a fluorescent chromophore) is a molecule which can be excited by absorbing light energy and re-emits energy at a specific wavelength. The wavelength, amount, and time before emission of the emitted energy depend on both the fluorophore and its chemical environment as the molecule in its excited state may interact with surrounding molecules.

[0070] The excitation energy may be a very narrow or a broader band of energy, or it may be all energies beyond a cut-off level. The emission energy and wavelength is usually more specific than the excitation energy, and it is usually of a longer wavelength or lower energy. Excitation energies range from ultraviolet through the visible spectrum, and emission energies may continue from visible light into the near infrared region.

[0071] Generally it is desired to select fluorophores with a relatively specific emission wavelength and energy for a simpler qualitative or quantitative determination of the target component. In particular it is desired that the emission wavelength is relatively specific, i.e. it should preferably have a wavelength band which in the method of determination is sufficiently narrow to be distinguished from other emissions.

[0072] The term "relative specific wavelength" means that the wavelength can be distinguished from other emitting wavelengths in the test.

[0073] In particular in situations where there are several different fluorophores and optionally several target components it is preferred that the fluorophores have relatively specific emission wavelengths such that emission from the respective fluorophores can be distinguished from each other.

[0074] The fluorophores can be any type of fluorophores which can be configured to bind to the capture sites of the magnetic particles. Fluorophores are well known to the skilled person and are commercially available.

[0075] Examples of quantum dots are described in US 7498177 and the quantum dots available from Life Technologies Europe BV. include more than 150 different product configurations with emission wavelength spanning in a broad wavelength range for examples quantum dots with the respective emission wavelengths: 525, 545, 565, 585, 605, 625, 655 and IR 705 and 800 nm. In an embodiment StreptAvidin, Biotin, antibodies and a number of different functionalities have been conjugated in the Invitrogen/life Technologies portfolio of Quantum dot products.

[0076] Examples of quantum dots also include quantum dots available from Ocean NanoTech, Springdale, Arkansas 72764, including more than 40 different product configurations with emission wavelength spanning in nm and a functionalized outer core of PEG or other biological compatible coating, for example with the respective emission wavelengths: 530, 550, 580, 590, 600, 610, 620 and 630 nm. The quantum dots from Ocean NanoTech include quantum dots with different functional groups e.g. amine, COOH, phenylboronic acid (PBA), as well as quantum dots with amphiphilic polymer and PEG coating. Other examples of quantum dots available from Ocean NanoTech are quantum dots with a sole core e.g. provided in toluene and with only an octadecylamine coat or with amphiphilic polymer and PEG coating.

[0077] In an embodiment the fluorophores are quantum dots or aromatic probes and/or conjugated probes, such as fluorescein, derivatives of benzene, metal-chalcogenide fluorophores or combinations thereof.

[0078] The fluorophores are preferably configured to bind to the capture sites of the magnetic particles by being coupled to a component which can bind to the capture sites of the magnetic particles.

[0079] In an embodiment the component is identical to the target component. In most situations it is most simple to configure the fluorophores to bind to the capture sites by coupling the fluorophores to a component which is identical to a target component.

[0080] In an embodiment the component is homolog to the target component. If for example the target component is a pathogen, an expensive or rare component or in certain other situations it may be very beneficial to configure the fluorophores to bind to the capture sites by coupling the fluorophores to a target component homolog.

[0081] The term "a component homolog to a target component" means herein that the component should have a homology to the target component such that at least some of the homolog components will bind to the capture sites of the magnetic particles when applied in a competitive assay of equal molar amount of the target component and the homolog component.

[0082] In a preferred embodiment of the invention the fluorophores are quantum dots that emit one or more discrete frequencies of light when stimulated by a light source. In this embodiment several different quantum dots can be excited with the same wavelength or at least

with a light beam having a relatively small band width.

[0083] Preferably each quantum dot comprises a core of an excitable material, such as a semiconductor nanoparticle or a rare earth doped oxide colloidal nanoparticle.

[0084] In an embodiment, the quantum dots comprise each a core with a size of up to about 25 nm, such as from 2-10 nm. The quantum dots preferably are coated with an organic coating, such as a polymer coating. Preferably the coating is coupled to a component which can bind to the capture sites of the magnetic particles e.g. such as described above.

[0085] In an embodiment of the invention, each of the quantum dots comprises a core of a binary semiconductor alloy, such as cadmium-selenide, cadmium-sulphide, indium-arsenide or indium-phosphide, covered with a transparent shell optionally comprising or consisting of Zinc sulphide.

[0086] The liquid sample is brought into contact with one or more of the fluorophores and the magnetic particles in the flow channel of the micro fluidic device.

[0087] The fluorophores and the magnetic particles are arranged in the flow channel of the micro fluidic device, and the method comprises feeding the liquid sample into the flow channel, the fluorophores and the magnetic particles are arranged in the flow channel at a distance from each other.

[0088] The fluorophores and the magnetic particles should preferably be applied in the flow channel of the micro fluidic device such that the capture sites of the magnetic particles do not capture any substantial amount of fluorophores prior to intermixing with the liquid sample. The fluorophores and the magnetic particles may be applied by any method e.g. by drying out in sections of the flow channel. In an embodiment the fluorophores and/or the magnetic particles are applied by producing the micro fluidic device in a substrate with a groove for the flow channel and a lid and the fluorophores and/or the magnetic particles are applied prior to adding the lid to the micro fluidic device.

[0089] In an embodiment the fluorophores and the magnetic particles are temporally immobilized in the flow channel of the micro fluidic device of the micro fluidic device such that they cannot bind to each other prior to the feeding of the liquid sample to the flow channel.

[0090] It is well known to temporally immobilize components in micro fluidic devices and any of such well known methods can be applied in the method of the invention.

[0091] The magnetic particles may for example be temporally immobilized by magnetic forces.

[0092] In an embodiment the fluorophores and/or the magnetic particles are temporally immobilized by being dried in the flow channel.

[0093] When the liquid sample comes in contact with the temporally immobilized fluorophores and/or the temporally immobilized magnetic particles the fluorophores and/or the magnetic particles are resuspended. The term

"resuspended" is herein used to mean that the fluorophores/magnetic particles are dissolved or suspended in the liquid.

[0094] In an embodiment the magnetic particles are permanently immobilized by magnetic forces and the liquid sample is forced to flow into contact with the magnetic particles. Since only a small amount of possible target components will come into reach of the capture sites of the magnetic particles in this embodiment, it is generally desired that the magnetic particles are free to intermix with the liquid sample, i.e. the magnetic particles should preferably not be permanently immobilized.

[0095] The liquid sample may be fed into the flow channel by any method and means, e.g. by pipetting, by using a syringe, by dripping into the inlet or by being sucked into the flow channel of the micro fluidic device in the form of a fluidic device.

[0096] In an embodiment of the invention the liquid sample is fed into the flow channel of the micro fluidic device by being sucked into the flow channel, the suction is provided by an actuator. The actuator is advantageously arranged to move a flexible wall section of the flow channel or of a sink section in fluid connection with the flow channel.

[0097] The actuator may preferably be arranged to move the flexible wall section of the flow channel or the sink section to provide a suction to suck the liquid sample into the flow channel. The flow channel preferably comprises a first feeding end and a second actuator end comprising the flexible wall section. In an embodiment the flow channel in combination with a sink section in fluid connection comprises a first feeding end and a second actuator end comprising the flexible wall section, where the second actuator end is a part of or all of the sink section.

[0098] In order to obtain an accurate quantitative determination, the method preferably comprises allowing the capture sites of the magnetic particles to capture possible target component in the liquid sample and/or fluorophores. The reaction time is usually very short e.g. from seconds to a few minutes, such as about 10 minutes or less. The reaction time is preferably about 1 minute or less. In a preferred embodiment, the method comprises stirring and/or pulsating the liquid sample in the flow channel. Such pulsation can for example be provided using an actuator. After a certain pre-selected reaction time the magnetic particles are at least temporally immobilized adjacent to the transparent window using a magnet.

[0099] In an embodiment where the magnet is a permanent magnet, the magnetic particles will immediately be attracted to the magnet after the sample is introduced into the flow channel. If the magnetic force is of a suitable strength e.g. as described below, the magnetic particles will be pulled towards the transparent window at a suitable speed such that the reaction with possible target components and fluorophores will have taken place before immobilization for at least a part of the capture sites

of the magnetic particles and preferably for most or substantially all of the capture sites. If the test is a quantitative test, the reaction time can usually be shorter than when the test is a qualitative test.

[0100] The transparent window is advantageously a window of the flow channel of the micro fluidic device.

[0101] The term "transparent" means herein that the window is transparent for the excitation and emission wavelengths of the fluorophores. Accordingly the windows need not be transparent for visual inspection, however, generally it is desired that the window or preferably the whole flow channel is transparent for visual inspection.

[0102] Generally it is known to produce micro fluidic devices and examples of general production methods and materials can be found in e.g. US 2010/0254858 and EP 1 827 693.

[0103] In an embodiment a wall section or the whole wall of the flow channel is preferably transparent.

[0104] Generally it is desired that the magnet has a magnetic field sufficiently strong to at least temporarily immobilize the magnetic particles adjacent to the transparent window.

[0105] The magnet may in principle be any type of magnet with a suitable strength. In an embodiment the magnet is selected to generate a magnetic field adjacent to the transparent window for immobilizing the magnetic particles, which magnet field is from about 0.05 to about 1 tesla, such as from about 0.1 to about 0.5 tesla, such as from about 0.15 to about 0.3 tesla.

[0106] The magnetic field need not be homogeneous. In an embodiment the magnet provides a magnetic field of from about 0.2 to about 0.3 tesla in a distance of about 1mm and a magnetic field of from about 0.01 to about 0.2 tesla in a distance of about 2.5 mm. In an embodiment the magnet provides a magnetic field in a distance of 2.5 mm which is about from 1/3 to 1/2 the strength of the magnetic field in a distance of about 1mm.

[0107] If the magnet is undesirably strong it may provide a too fast immobilization of the magnetic particles i.e. the capture sites of the magnetic particles may not have suitable time to bind target component or fluorophores prior to immobilization of the magnetic particles. This is of course only relevant if the magnet is a permanent magnet. If the magnet is undesirably weak, it may not be able to immobilize a sufficient amount of magnetic particles. By a few tests the skilled person can find a suitable magnet strength adapted to a specific method of the invention.

[0108] The magnet may preferably be a permanent magnet, for the reason of simplification and low cost. However, in an embodiment an electromagnet, such as an adjustable electromagnet may be suitable e.g. if magnetic forces are applied in the mixing of the liquid sample with the fluorophores and/or the magnetic particles.

[0109] The magnet may be movable or stationary depending on the setup for performing the method of the invention. For a simple structure it is desired that the mag-

net is stationary arranged to immobilize the magnetic particles for excitation and read out adjacent to the transparent window.

[0110] In a preferred embodiment the at least temporally immobilized magnetic particles are subjected to the electromagnetic beam such that at least a part of possible fluorophores captured by the capture sites of the magnetic particles are excited, where after the emitted signal from the possibly captured fluorophores are read and a quantitative or qualitative determination of the target component based on the read signal is performed.

[0111] It has been found that where the fluid in the flow channel after the magnetic particles are immobilized using the magnet is at standstill, the at least temporarily immobilized magnetic particles remain immobilized at least for a time such as up to several minutes after releasing the magnetic particles from influence of the magnetic force of the magnet. Thereby the magnet can be removed from the transparent window and making room for an emitter to excite the fluorophores and a reader to read out any signal from the fluorophores. Thereby the emitter and/or reader can be positioned where the magnet previously was positioned which has shown to provide extremely reliable results. In an embodiment the emitter is arranged to emit the electromagnetic beam via one or more emitting optical fibers comprising output ends arranged immediately adjacent to the transparent window (e.g. where the magnet was arranged when immobilizing the magnetic particles) In an embodiment the receiver is arranged to receive the signal from the fluorophores via one or more receiver optical fibers comprising input ends arranged immediately adjacent to the transparent window (e.g. where the magnet was arranged when immobilizing the magnetic particles).

[0112] The output ends of the emitting optical fibers and the input ends of the receiver optical fibers are advantageously arranged in a pattern. In an embodiment the output ends of the emitting optical fibers are arranged in a circle surrounding the input ends of the receiver optical fibers. In an embodiment the input ends of the receiver optical fibers are arranged in a circle surrounding the output ends of the emitting optical fibers. In an embodiment one or more lenses are arranged to collect the signal and direct it to the input ends of the receiver optical fibers.

[0113] Methods of excitation of fluorophores are well known in the art. The exciting wavelength is preferably adjusted to the excitation peak of the fluorophores. In an embodiment the excitation light is a relative band emission and preferably relatively low energy, such that the excitation light does not result in an undesired heating of the liquid sample or the elements therein.

[0114] In an embodiment the micro fluidic device is kept at a controlled temperature to optimize the bonding and ensuring that an undesired temperature does not interfere with the binding assay.

[0115] In an embodiment of the invention, the plurality of fluorophores is substantially identical.

[0116] If only one target component is to be determined, it is often desired that the fluorophores applied are substantially identical with respect to excitation and emitting, however, it should be understood that one target component can in principle be detected using different types of fluorophores in the same test.

[0117] In a preferred embodiment of the invention, the plurality of fluorophores comprises two or more groups of fluorophores, wherein the two or more groups of fluorophores differ from each other with respect to types, sizes, coatings, shape and/or amounts.

[0118] If two or more groups of fluorophores are present they may in principle be selected independently of each other, but preferably such that they emit at different wavelengths. In this situation it is particularly preferred to apply quantum dots as fluorophores, because quantum dots at different sizes emit at different wavelengths while they are excited at substantially the same wavelength.

[0119] The amount of fluorophores is preferably selected to provide an estimated competition for possible target components on the liquid sample. The amount of fluorophores can be determined by a few tests. A possible outset for selecting the amount of fluorophores is to select an amount of about 0.02 to about 100 times the amount which corresponds to the maximal estimated amount of target component in the liquid sample, such as an amount of about 1 to about 50 times or an amount of about 10 to about 50 times the amount which corresponds to the maximal estimated amount of target component in the liquid sample. For improved accuracy of the result, it is often desired to repeat the determination of a target component in a liquid sample using different amounts of fluorophores.

[0120] The amount of fluorophore may for example vary from about 0.02 to about 50 nM (nano mol), preferably from about 0.1 to about 10 nM.

[0121] The magnetic particles may be equal or different from each other. In an embodiment the magnetic particles are substantially identical with respect to capture sites and optionally with respect to number of capture sites and/or size.

[0122] In an embodiment the plurality of magnetic particles comprises two or more groups of magnetic particles, wherein the two or more groups of magnetic particles differ from each other with respect to e.g. with respect to size, capture sites number and/or type.

[0123] In an embodiment of the invention where the method comprises quantitative or qualitative determination of two or more target components in a liquid sample, the magnetic particle comprises one or more types of capture sites for the two or more target components, the capture sites for one target component preferably differs from the capture sites for another target component. For example one group of magnetic particles can comprise one type of capture sites and another group of magnetic particles can comprise another type of capture sites.

[0124] The plurality of fluorophores may e.g. comprise

at least one group of fluorophores configured to bind to one capture site for one target component and at least another group of fluorophores configured to bind to the capture site for another target component.

5 **[0125]** By a few examples and based on the teaching herein the skilled person can find suitable fluorophores and magnetic particles for a given test according to the method of the invention.

10 **[0126]** In a preferred embodiment of the invention, the method comprises performing two or more parallel assays on the liquid sample for quantitative or qualitative determination of the target component(s), each assay comprises

- 15 • bringing a part of the liquid sample into contact with the fluorophores and the magnetic particles in a micro fluidic device comprising a transparent window; and
- 20 • at least temporally immobilizing the magnetic particles adjacent to the transparent window using a magnet, emitting exciting electromagnetic beam(s) towards the immobilized magnetic particles, reading signals emitted from fluorophores captured by the immobilized magnetic particles.
- 25

[0127] Preferably the fluorophores used in one of the two or more parallel assays differ from the fluorophores used in another one of the two or more parallel assays.

30 **[0128]** For example the fluorophores used in one of the two or more parallel assays differ from the fluorophores used in another one of the two or more parallel assays with respect to types, sizes, coatings, shape and/or amounts.

35 **[0129]** In an embodiment of the invention the magnetic particles used in one of the two or more parallel assays differ from the magnetic particles used in another one of the two or more parallel assays. For example the magnetic particles used in one of the two or more parallel assays differ from the magnetic particles in another one of the two or more parallel assays with respect to types, sizes, coatings, shape and/or amounts.

40 **[0130]** In an embodiment the two or more parallel assays are performed simultaneously in the same micro fluidic device. The two or more parallel assays may e.g. be performed in respective flow channels, such as in parallel flow channels of the same micro fluidic device.

45 **[0131]** In an embodiment of the invention, the quantitative or qualitative determination of target component(s) in a liquid sample is performed by comparing the read signal(s) with a reference schedule.

[0132] The reference schedule can be any type of reference schedule which can be applied for calibrating the read signal, for example such as it is generally known in the art.

55 **[0133]** In an embodiment of the invention, the quantitative or qualitative determination of target component(s) in a liquid sample is performed by comparing the read

signal(s) with signals obtained from liquid samples with a known composition, e.g. by using an artificial intelligent processor.

[0134] In an embodiment of the invention, the quantitative or qualitative determination of target component(s) in a liquid sample is performed by multiplexing the read signal(s) from different groups of fluorophores e.g. from the same assay, from fluorophores from parallel assays and/or from fluorophores in reference tests of known or unknown liquid samples.

[0135] The invention also comprises a system for quantitative or qualitative determination of a target component in a liquid sample.

[0136] The system of the invention for quantitative or qualitative determination is specifically suitable for use for performing the method of the invention, and accordingly the system for quantitative or qualitative determination and embodiments thereof has at least some of the above mentioned benefits.

[0137] The system for quantitative or qualitative determination of a target component in a liquid sample comprises

- a micro fluidic device comprising at least one flow channel with a transparent window and an inlet for the liquid sample;
- a plurality of magnetic particles comprising one or more capture sites for the target component on their respective surfaces;
- a plurality of fluorophores configured to bind to the capture sites of the magnetic particles;
- a magnet arranged to at least temporally immobilize the magnetic particle adjacent to the transparent window;
- an emitter for exciting the fluorophores, and
- a reader for reading signals emitted from the fluorophores,

wherein the fluorophores and the magnetic particles are arranged at a distance from each other in the flow channel.

[0138] Advantageously the micro fluidic device is as described elsewhere herein. The magnetic particles, the fluorophores and the magnet may e.g. be as described above.

[0139] In an embodiment the micro fluidic device is of polymer and or glass.

[0140] In an embodiment the micro fluidic device comprises a substrate with a groove for the flow channel and a foil covering the flow channel.

[0141] The micro fluidic device comprises preferably an excitation and read out zone which is also referred to as a reading zone and which is provided in the form of

the transparent window, which is preferably transparent for at least the excitation and emitting wavelengths of the fluorophores.

[0142] In an embodiment the excitation and read out zone is identical to a zone where the magnet is positioned when it is acting on the magnetic particle to immobilize the magnetic particles. After the magnetic particles have been immobilized using the magnet and any liquid in the flow channel is at standstill, the magnet is removed while the magnetic particles remain immobilized at least for a sufficient time to excite the fluorophore and read the signal emitted from the fluorophore.

[0143] The emitter and the reader are advantageously a common emitter and reader unit.

[0144] In an embodiment the emitter comprises emitting optical fibers comprising output ends and the receiver comprises one or more receiver optical fibers comprising input ends. Advantageously fiber sections comprising the optical fiber output ends of the emitter and fiber sections comprising the optical fiber input ends of the reader are connected to each other to form a common emitting-reading fiber bundle. The output ends of the emitting optical fibers and the input ends of the receiver optical fibers are advantageously arranged in a pattern e.g. as described above.

[0145] The flow channel of the micro fluidic device may in principle have any shape. In an embodiment the flow channel comprises an elongate flow section and one or more chamber sections (chamber sections that have a substantially larger cross-section than the flow section). The fluorophores and the magnetic particles may for example be temporally immobilized in such chamber sections.

[0146] In an embodiment of the system of the invention for quantitative or qualitative determination the micro fluidic device is of polymer and or glass or a combination thereof. In a preferred embodiment the micro fluidic device is of polymer. The polymer micro fluidic device is easy and cost-effective to produce. The micro fluidic device preferably comprises a substrate with a groove for the flow channel and a foil covering the flow channel.

[0147] In an embodiment the micro fluidic device comprises an inlet to the flow channel. The inlet is for example an opening for suction, a capillary inlet or a membrane covered inlet.

[0148] In an embodiment of the invention the inlet of the micro fluidic device is a membrane covered inlet. In this embodiment the liquid sample can for example be introduced into the flow channel using a syringe or similar needle assisted device which can be used to penetrate the membrane. The membrane may e.g. simultaneously provide an escape for gas in the flow channel.

[0149] In an embodiment of the invention the inlet of the micro fluidic device is a capillary inlet, meaning that the liquid sample can be drawn into the flow channel using capillary forces. In this embodiment it is desired that the inner surfaces of the flow channel, in particular adjacent to the inlet, have a relatively high surface tension

and have sufficiently small dimensions for providing the capillary forces. It is well known in the art to provide micro fluidic devices with a capillary inlet. Most polymers have a relatively low surface tension and often it is required to treat the surface of polymer micro fluidic device where the inner surfaces of the flow channel should provide capillary forces for a liquid e.g. an aqueous liquid.

[0150] In an embodiment of the invention the inlet of the micro fluidic device is an opening for suction, i.e. the micro fluidic device is configured such that the liquid sample is adapted to be sucked into the flow channel. In this embodiment the inner surfaces of the flow channel need not provide capillary forces and even when the micro fluidic device is of a material with a low surface tension, such surface need not be treated for increasing the surface tension. The micro fluidic device with a suction inlet is therefore very simple to produce and can be provided at relatively low cost.

[0151] In an embodiment of the invention the micro fluidic device comprises an inlet for suction in the liquid sample. Advantageously the micro fluidic device comprises a flexible wall section and the system can beneficially comprise an actuator, where the actuator is arranged to move the flexible wall section. The actuator is e.g. a step motor driven actuator.

[0152] In an embodiment of the invention where system comprises an actuator and where the inlet of the micro fluidic device comprises a flexible wall section and the inlet is an opening for suction, the inlet and the actuator are arranged such that the upon activation of the actuator, the flexible wall section will be moved and air will be pressed out of the flow channel where after the flexible wall will return to its initial position and the liquid sample will be sucked into the flow channel. Thereby a simple and effective suction of the liquid sample into the flow channel and a simple and effective mixing of the sample with the fluorophores and magnetic particles can be obtained.

[0153] In an embodiment of the invention the micro fluidic device comprises a sink section and the flow channel is in fluid communication with the sink section.

[0154] The sink section of the micro fluidic device is a section which is applied in a distance from the transparent window where the magnetic particle is at least temporarily immobilized for excitation and read out. The sink section is in an embodiment applied to collect the sample or most of the sample during or after the test has been completed. By collecting the sample or most of the sample while simultaneously immobilizing the magnetic particles adjacent to the transparent window for excitation and read out, the risk of obtaining false signals due to fluorophores in the sample can be highly reduced.

[0155] Advantageously the sink section is positioned remotely to the inlet to the flow channel. Preferably the fluid introduced via the inlet must pass the transparent window where the magnetic particle is at least temporarily immobilized for excitation and read out before the liquid reaches the sink section.

[0156] The terms "slink" and "slink section" are used interchangeably

[0157] The flow channel may have any shape and is preferably adapted for performing determinations on relatively small volumes of liquid sample, such as from about 1 μ l to about 1 ml, preferably from about 5 μ l to about 0.5 ml. The flow channel can have any shape e.g. with a cross sectional shape selected from round, ellipsoidal, semi ellipsoidal, quadrilateral polygonal, square, rectangular and trapezoidal shapes, where any edges optionally being rounded. In one embodiment the micro fluidic device comprises two or more distinct flow channel sections, e.g. a channel section for mixing the liquid sample with the fluorophores and/or the magnetic particles and a channel section with a transparent window for at least temporarily immobilizing the magnetic particles for excitation of optional captured fluorophores and for reading out possible emission energy.

[0158] In an embodiment of the invention the microfluidic device comprises at least one gas escape opening for allowing gas to escape from the flow channel. The gas escape opening may be of any type and shape e.g. as known from prior art microfluidic devices. The gas escape opening may for example be arranged to allow gas to escape completely out of the microfluidic device or it may allow the gas to escape into a gas collecting chamber e.g. in the form of an inflatable unit.

[0159] In an embodiment of the invention the microfluidic device comprises a flexible wall section which can be used to create a suction at the inlet of the flow channel. In this embodiment the inlet can function as a gas escape opening.

[0160] In an embodiment the micro fluidic device comprises two or more flow channels, and the two or more flow channels comprise a common section or are in fluid connection with a common sink section, where the common section or the common sink section comprises a flexible wall section which can be used to create a suction at the inlets of the flow channels.

[0161] In an embodiment the micro fluidic device comprises two or more flow channels, and the two or more flow channels or one or more sink sections in fluid connection comprise each a flexible wall section which can be used to create a suction at the respective inlets of the flow channels. In this embodiment suction can be applied individually in the respective flow channels. The flexible wall section is in an embodiment applied as a wall section of a sink section where the sample or parts thereof can be collected after performing the test. The sink section is e.g. as described above.

[0162] In an embodiment the flexible wall section is used to pump out the sample after the magnetic particles have been mixed with the sample and the fluorophores while simultaneously immobilizing the magnetic particles adjacent to the transparent window for excitation and read out, thereby reducing the risk of obtaining false signals due to fluorophores remaining in the sample.

[0163] In an embodiment where the micro fluidic device

comprises a flow channel in fluid connection with a sink for collecting sample and optionally a flexible wall suitable for pumping the sample into and out of the sink, a sample modifier such as a surfactant is applied in the sink. When the sample is pumped into the sink using the flexible wall section or other pumping means the sample will be intermixed with the surfactant and accordingly the surface tension of the sample is reduced. By reintroducing the sample into the area of the flow channel comprising the transparent window, the magnetic particles immobilized adjacent to the transparent window will be washed with the modified sample. The modifier applied in the sink may e.g. be in a dry form such that it will not be mixed with the sample until the sample is introduced into the sink.

[0164] In an embodiment the flexible wall section is used to pump out the sample after termination of the test. Whether it is preferred to collect the sample in the sink section, to pump out the sample or to let the sample be distributed in the flow channel depends largely on the kind and the toxicity of the sample applied. If for example there is risk of undesired contamination or if the sample potentially comprises elements that are undesirable to spread e.g. bacteria, viruses or similar, it may be desired to collect the sample in the sink section during or after performing the test.

[0165] In an embodiment the flow channel of the micro fluidic device comprises one or more chambers, e.g. for mixing the liquid sample with the fluorophores and/or the magnetic. In general it is desired that the flow channel comprises at least one liquid flow channel section which has at least one dimension (often the width dimension) of at least about 100 μm , such as at least 500 μm . In practice it can be as wide as handling will allow. The other dimension(s), e.g. the depth of the channel, is preferably smaller than the width, such as half the width or e.g. down to about 25 μm or down to about 10 μm , if desired.

[0166] In this context a chamber of a flow channel means a subsection of the flow channel that has at least 25 %, such as at least 50 %, larger cross-sectional area than an adjacent section of the flow channel. The chamber may for example have a larger cross sectional area than an adjacent channel section by being wider. The depth of the flow channel may be substantially constant or it may vary.

[0167] In an embodiment of the system of the invention for quantitative or qualitative determination, the micro fluidic device comprises an excitation and read out zone in the form of a length section comprising the transparent window, the window is transparent for at least the exciting and emitting wavelengths of the fluorophores.

[0168] In an embodiment of the system of the invention for quantitative or qualitative determination, the micro fluidic device comprises an excitation and read out section that has a length dimension of at least about 1 mm, such as at least about 3 mm, such as at least about 5 mm.

[0169] The read out section is preferably formed as a narrowed part of the flow channel or as an expanded part of the flow channel in order to provide a simple positioning

of the micro fluidic device in relation to the emitter and reader.

[0170] According to the system of the invention at least the window of the micro fluidic device is of a transparent material.

[0171] In an embodiment the whole flow channel is visible due to transparency of the material. In an embodiment the whole micro fluidic device is of a transparent material

[0172] In a preferred embodiment at least the transparent window is transparent to the exciting wavelength(s) and emitting wavelength(s) of the fluorophores. In an embodiment at least the transparent window is transparent to at least one wavelength selected from Infrared light (about 700 nm to about 1000 μm), visible light (about 400 nm to about 700 nm), UV light (about 400 nm to about 10 nm) about and X-ray light (about 10 nm to about 0.01 nm).

[0173] It is in an embodiment desired to apply short wave light for the determination, i.e. the fluorophores are preferably excitable by short wavelength energy where the heat generation is relatively small and will not interfere with the determination.

[0174] Examples of materials which may be used for the micro fluidic device comprise materials selected from glass and polymer, preferably polymers selected from cyclic olefin copolymers (COC), acrylonitrile-butadiene-styrene copolymer, polycarbonate, polydimethyl-siloxane (PDMS), polyethylene (PE), polymethylmethacrylate (PMMA), polymethylpentene, polypropylene, polystyrene, polysulfone, polytetra-fluoroethylene (PTFE), polyurethane (PU), polyvinylchloride (PVC), polyvinylidene chloride (PVDC), polyvinylidene fluoride, styrene-acryl copolymers polyisoprene, polybutadiene, polychloroprene, polyisobutylene, poly(styrene-butadiene-styrene), silicones, epoxy resins, Poly ether block amide, polyester, acrylonitrile butadiene styrene (ABS), acrylic, celluloid, cellulose acetate, ethylene-vinyl acetate (EVA), ethylene vinyl alcohol (EVAL), fluoroplastics, polyacetal (POM), polyacrylates (acrylic), polyacrylonitrile (PAN) polyamide (PA), polyamide-imide (PAI), polyaryletherketone (PAEK), polybutadiene (PBD), polybutylene (PB), polybutylene terephthalate (PBT), polyethylene terephthalate (PET), polycyclohexylene dimethylene terephthalate (PCT), polyketone (PK), polyester/polythene/polyethylene, polyetheretherketone (PEEK), polyetherimide (PEI), polyethersulfone (PES), polyethylenechlorinates (PEC), polyimide (PI), polylactic acid (PLA), polymethylpentene (PMP), polyphenylene oxide (PPO), polyphenylene sulfide (PPS), polyphthalamide (PPA), and mixtures thereof.

[0175] In an embodiment the micro fluidic device is provided from a base part of a rigid material - e.g. produced by injection molding or by laser carving in a substrate. The base part is covered with a foil which is bonded to the base part to form the flow channel and optionally sink section.

[0176] In an embodiment of the invention the micro flu-

idic device comprises two or more flow channels optionally for performing parallel tests, the two or more flow channels optionally have a common inlet.

[0177] In an embodiment of the system of the invention for quantitative or qualitative determination, the system comprises a temperature regulator for regulating the temperature of the liquid sample in the flow channel. For some tests the reaction between possible target component and capture sites is temperature sensitive and accordingly it can be desirable to regulate the temperature. The temperature regulator can for example comprise a peltier element, a thin film heating element and/or other resistive heating elements.

[0178] In an embodiment of the system of the invention for quantitative or qualitative determination, the magnetic particles are coated magnetic particles comprising a coating comprising the captures sites, wherein the capture sites are selected to be capture sites for the target component, such as a biomolecule.

[0179] In an embodiment of the system of the invention for quantitative or qualitative determination, the fluorophores are quantum dots or aromatic probes and/or conjugated probes, the fluorophores are preferably quantum dots.

[0180] In an embodiment of the system of the invention for quantitative or qualitative determination, the fluorophores are configured to bind to the capture sites of the magnetic particles by being coupled to a component which can bind to the capture sites of the magnetic particles, the component is preferably identical or homolog to the target component.

[0181] In an embodiment of the system of the invention for quantitative or qualitative determination, the fluorophores and the magnetic particles are temporally immobilized in the flow channel of the micro fluidic device of the micro fluidic device such that they cannot bind to each other prior to the feeding of a liquid sample to the flow channel.

[0182] In an embodiment of the system of the invention for quantitative or qualitative determination, the magnet is arranged to at least temporally immobilize the magnetic particle adjacent to the transparent wall section for a sufficient time to excite at least a part of possible fluorophores captured by the capture sites of the magnetic particles by the emitter and to read out possibly emitted signal from possibly captured fluorophores.

[0183] Emitters and readers for electromagnetic waves are well known in the art, and when the fluorophores have been selected the skilled person will in a simple manner be able to select an emitter and reader that are useful in combination with the fluorophores.

[0184] In an embodiment of the system of the invention for quantitative or qualitative determination, the emitter is a light emitting diode or a laser which is capable of emitting electromagnetic radiation comprising the exciting wavelength of the fluorophores.

[0185] In an embodiment of the system of the invention for quantitative or qualitative determination, the emitter

is configured to emit electromagnetic radiation directed at the transparent window, the window has a planar surface, the emitter is preferably configured to emit electromagnetic radiation directed at the transparent window with an angle to the surface of the window which is from about 20° to about 170°, such as from about 30° to about 150°. Preferably the surface of the window is substantially plane in order to optimize the exciting and emitting functions.

[0186] In an embodiment of the system of the invention for quantitative or qualitative determination, the reader is configured for reading signals emitted from fluorophores captured by magnetic particles which are temporally immobilized adjacent to the window.

[0187] The emitter and the reader are advantageously a common emitter and reader unit.

[0188] In an embodiment the emitter comprises emitting optical fibers comprising output ends and the receiver comprises one or more receiver optical fibers comprising input ends. Advantageously fiber sections comprising the optical fiber output ends of the emitter and fiber sections comprising the optical fiber input ends of the reader are connected to each other to form a common emitting-reading fiber bundle. The output ends of the emitting optical fibers and the input ends of the receiver optical fibers are advantageously arranged in a pattern e.g. as described above.

[0189] In an embodiment of the system of the invention for quantitative or qualitative determination, the system comprises a computer for performing the quantitative or qualitative determination of target component(s) in a liquid sample based on the read signal(s). The computer is preferably programmed to perform a quantitative and/or qualitative determination of the target component in the liquid sample based on the read signal.

[0190] In an embodiment the computer comprises a memory for storing of read signal(s) and/or quantitative or qualitative determinations performed.

[0191] In an embodiment the computer comprises a memory, which memory comprises a reference schedule for comparing the read signal(s) to perform the determination. The reference schedule may preferably comprise sets of a quantitative or qualitative determination with read signal(s), for example a set of data comprises a) the result(s) of read signal(s) for a liquid sample with a known content of the target component and b) the known content of the target component.

[0192] In an embodiment the computer is an artificial intelligent processor, programmed to compare read signal(s) with stored signals obtained from liquid samples with known compositions.

[0193] In an embodiment the system comprises a signal processor comprising the computer wherein the signal processor is configured to multiplex signals from different groups of fluorophores, from fluorophores from parallel assays and/or from fluorophores in reference tests of known or unknown liquid samples.

[0194] In an embodiment the system comprises a sig-

nal processor comprising the computer wherein the signal processor is configured to multiplex signals from different groups of fluorophores applied in same assay.

[0195] Multiplexing of signals is well known in the art and has also been applied in the art of analyzing test samples to quantify two or more targets labeled with fluorophores emitting different wavelengths. Reference is made to for example US 2009/0270269 and WO 2010/141105 and further information about multiplexing can also be found in "luminescent quantum dots for multiplexed biological detection and imaging" Chan et al. Current Opinion in Biotechnology 2002, 13:40-46, Elsevier Science.

[0196] When performing the quantitative or qualitative determination using multiplexing it is preferred that the fluorophores applied are quantum dots. According to the invention it has been found that by using quantum dots as fluorophores and multiplexing the signals it is possible to quantitatively determine a plurality of target components simultaneously, e.g. 10 or more or even 50 or more.

[0197] The emitter, the reader and the signal processor comprising the computer are advantageously in form of a common or at least interconnected unit.

[0198] The invention also relates to a micro fluidic device for use in preparing a liquid sample for optical analysis for quantitative or qualitative determination of a of target component in the sample. The micro fluidic device comprises at least one flow channel with a transparent window and an inlet for the liquid sample, the micro fluidic device further comprises in its flow channel

- a plurality of magnetic particles comprising capture sites for the target component on their surfaces; and
- a plurality of fluorophores configured to bind the capture sites of the magnetic particles,

and wherein the fluorophores and the magnetic particles are arranged at a distance from each other in the flow channel.

[0199] The micro fluidic device is preferably a micro fluidic device as described above.

[0200] In an embodiment the micro fluidic device for use in preparing a liquid sample for optical analysis for quantitative or qualitative determination of a of target component in the sample which micro fluidic device comprises a substrate with a groove for a flow channel and a foil covering the flow channel, the flow channel comprises a transparent window and an inlet for suction in the liquid sample. The micro fluidic device comprises a flexible wall section of the flow channel or of a sink section in fluid connection with the flow channel. The flexible wall section can be moved such that air will be pressed out of the flow channel where after the flexible wall will return to its initial position.

[0201] In an embodiment of the invention the micro fluidic device comprises a sink section and the flow channel is in fluid communication with the sink section.

[0202] The sink section of the micro fluidic device is a section which is applied in a distance from the transparent window where the magnetic particle is at least temporarily immobilized for excitation and read out. The sink section is in an embodiment applied to collect the sample or most of the sample during or after the test has been completed. Advantageously the sink section is positioned remotely to the inlet to the flow channel.

[0203] Further preferred embodiments of the micro fluidic device are as described above.

[0204] It should be emphasized that the term "comprises/comprising" when used herein is to be interpreted as an open term, i.e. it should be taken to specify the presence of specifically stated feature(s), such as element(s), unit(s), integer(s), step(s) component(s) and combination(s) thereof, but does not preclude the presence or addition of one or more other stated features.

[0205] All features of the inventions including ranges and preferred ranges can be combined in various ways within the scope of the invention, unless there are specific reasons for not combining such features.

BRIEF DESCRIPTION OF DRAWINGS AND EXAMPLES

[0206] The invention will be explained more fully below in connection with examples and preferred embodiments and with reference to the drawings in which:

FIG. 1a is a schematic top view of a micro titer plate.

FIG. 1b is a schematic cross sectional view seen in the line A-A' of Fig. 1.

FIG. 2 is a schematic top view of a micro fluidic device suitable for performing the method of the invention.

FIG. 3 is a schematic sectional side view seen in the line B-B' of FIG. 2.

FIG. 4 is a schematic top view of micro fluidic device suitable for performing the method of the invention and with temporarily immobilized magnetic particles and temporarily immobilized fluorophores.

FIG. 5 is a schematic illustration of the system of the invention comprising a micro fluidic device, an emitter and a reader.

FIG. 6 is a schematic illustration of a fluorophore in the form of a quantum dot suitable for use in the invention.

FIG. 7a, 7b and 7c are schematic illustrations of a performance of the method of the invention.

FIG. 8a, 8b and 8c are schematic illustrations of another performance of the method of the invention.

FIG. 9 is a schematic side view of an emitter-reader assembly.

[0207] The figures are schematic and may be simplified for clarity. Throughout, the same reference numerals are used for identical or corresponding parts.

[0208] FIGs. 1a and 1b show a test plate suitable for performing some prior art methods. The shown test plate is a micro titer plate with 12 x 8 wells 1.

[0209] Micro titer plates are well known in the art under many names, such as well plates and micro plates. A micro titer plate is a generally flat plate with multiple "wells" used as small test tubes. The shown micro titer plate comprises a thin cover film 2, which is peeled off prior to use of the titer plate. The cover film 2 can be divided into sections, such that it can be peeled off in sections, e.g. such that only one or only a number less than all wells are uncovered by removal of a section of the cover film 2. The micro titer plate has an edge 4 for reducing spill.

[0210] Each well 1 of a micro plate typically holds somewhere between tens of nanolitres to several millilitres of liquid. Wells of a suitable micro titer plate can in principle have any shape, such as circular or square, and their respective bottom parts can be rounded or plane. In the shown micro titer plate, the wells 1 are round and with plane bottom parts 3. The round bottom parts 2 of the respective wells 1 constitute the transparent window usable for exciting and reading out. FIGs. 2 and 3 show a test plate suitable for being applied in the present invention. The shown test plate is a micro fluidic device. Although any micro fluidic devices in principle could be applied in the present invention, the micro fluidic device shown is particularly designed for the purpose and provides additional benefits to the present invention as described herein.

[0211] The micro fluidic device comprises a substrate 12 with three flow channels 11. The channels 11 are provided in the form of grooves covered with a foil 11a. Each channel 11 comprises an inlet 13 and the channels 11 is in fluid connection with a common sink 14.

[0212] The inlet 13 is in the form of a well shaped inlet.

[0213] The common sink 14 of the micro fluidic device comprises a flexible wall section 15. The flexible wall section 15 can be moved e.g. using a not shown actuator as described above.

[0214] By pressing the flexible wall section 15 it will be moved and air will be pressed out of the channels 11 where after the flexible wall section 15 will return to its initial position and a liquid sample arranged in the inlet will be sucked into the channel to a desired position. By further manipulating the flexible wall section the liquid sample can be drawn further into the channels 11 or it can be pulsated in the channels. Finally the flexible wall section 15 can be manipulated to collect the sample in the sink and to reflush the sample into the channels, if desired. The flexible wall section 15 thereby provides a simple and cheap method of controlling the liquid sample

in the micro fluidic device.

[0215] The micro fluidic device also comprises an indent which provides a read out section 16 for the channels 11. In the read out sections 16 of the channels 11, the channels comprise a transparent window and the magnetic particles can be temporally immobilized using a not shown magnet.

[0216] FIG. 4 shows another preferred micro fluidic device suitable for use in the invention.

[0217] The micro fluidic device comprises a substrate 22 with five flow channels 21. Each channel 21 comprises an inlet 23 and is in fluid connection with a sink 24 with a not shown flexible wall section.

[0218] The micro fluidic device also comprises an indent which provides a read out section 26 for the channels 21, where the channels comprise a transparent window and the magnetic particles can be temporally immobilized using a not shown magnet.

[0219] Each channel 21 comprises temporally immobilized magnetic particles and temporally immobilized fluorophores. The micro fluidic device is divided into zones comprising zone 0 which is the inlet zone, zone 1 and zone 2 which comprise temporally immobilized fluorophores 18 and magnetic particles 17 arranged such that they do not react until they are in contact with the liquid sample, zone 3 which is the read out zone and zone 4 which is the sink zone.

[0220] In an embodiment zone 1 comprises temporally immobilized fluorophores and zone 2 comprises temporally immobilized magnetic particles.

[0221] In an embodiment zone 1 comprises temporally immobilized magnetic particles and zone 2 comprises temporally immobilized fluorophores.

[0222] The micro fluidic device could comprise several subzones of zone 1 and zone 2, if desired.

[0223] In use the liquid sample is fed to the inlet 23, the sample is sucked into zone 1 of the channels using the flexible wall section. Optionally the liquid sample is pulsated in zone 1 to dissolve or resuspend the immobilized elements 17 in zone 1. Thereafter the liquid sample is drawn further into the channels 21 to zone 2 for dissolving or resuspending the immobilized elements 17 in zone 2. After a preselected incubation time the liquid sample is drawn fully into the sinks 24. The magnetic particles are immobilized in the read out zone 3. If desired, the liquid sample can be reintroduced into the channels 21 by using the flexible wall of the sinks 24 and the immobilized magnetic particles can be flushed using the liquid sample to remove not immobilized fluorophores and other elements that could potentially provide noise.

[0224] FIG. 5 shows a system of the invention comprising a support element 32 supporting a micro fluidic device 31, an emitter 38 and a reader 39 coupled to a computer 34. The micro fluidic device comprises a read out section 36. The support element 32 comprises a temperature control element 35 for maintaining the liquid sample at a desired temperature during the test. The support element 32 further comprises a magnet 33. The mi-

cro fluidic device is arranged such that the magnet is located adjacent the read out section 36 to thereby temporarily immobilize the magnetic particles in the read out section 36. The emitter 38 is configured to emit electromagnetic radiation 38a directed at the read out section 36 to thereby excite fluorophores on the immobilized magnetic particles. The reader 39 is configured to read signals 39a emitted from fluorophores captures by the immobilized magnetic particles and the read signals are transmitted to the computer 34 for processing to quantitative and/or qualitative determination of target compound(s).

[0225] FIG. 6 shows a fluorophore in the form of a quantum dot suitable for use in the invention. The quantum dot comprises a core 41 of a binary semiconductor alloy covered by a transparent shell 42 which is at least transparent for the wavelength emitted by the core. The shell 42 is further covered by an organic coating 43, such as a polymer coating which is coupled to one or more not shown components which can bind to the capture sites of the magnetic particles e.g. such as described above.

[0226] FIGs. 7a, 7b and 7c show a performance of the method of the invention in three steps. Step 1 is illustrated in FIG. 7a. Sample with the target component 51 is mixed with fluorophores 52 coupled to homologue target component 53. The relative amount of target component 51 to fluorophores 52 coupled to homologue target component 53 is relatively low. Step 2 is illustrated in FIG. 7b. The mixture of target component 51 and fluorophores 52 coupled to homologue target component 53 is further mixed with magnetic particles 54 carrying capture sites 55 for the target component 51 and the homologue target component 53. Step 3 is illustrated in fig 7c. Target component 51 and the homologue target component 53 are captured by the capture sites 55 carried by the magnetic particles 54. In the illustration shown, only the homologue target component 53 is captured by the capture sites 55. This is shown to illustrate that the amount of captured homologue target component 53 is relatively high and accordingly the amount of immobilized fluorophores 52 is relatively high. When the magnetic particles 54 are immobilized using a magnet arranged adjacent to the transparent window, and the fluorophores 52 are excited, the emitted signal from the fluorophores 52 is relatively high, and the amount of target component 51 can be determined.

[0227] FIGs. 8a, 8b and 8c show another performance of the method of the invention in three steps. Step 1 is illustrated in FIG. 8a. Sample with the target component 61 is mixed with fluorophores 62 coupled to homologue target component 63. The relative amount of target component 61 to fluorophores 62 coupled to homologue target component 63 is relatively high. Step 2 is illustrated in FIG. 8b. The mixture of target component 61 and fluorophores 62 coupled to homologue target component 63 is further mixed with magnetic particles 64 carrying capture sites 65 for the target component 61 and the homo-

logue target component 63. Step 3 is illustrated in Fig 8c. Target component 61 and the homologue target component 63 are captured by the capture sites 65 carried by the magnetic particles 64. In the illustration only the target component 61 captured by the capture sites 65 is shown to illustrate that the amount of captured target component 61 is relatively high and accordingly the amount of immobilized fluorophores 62 is relatively low or there may be none at all and when the magnetic particles 64 are immobilized using a magnet adjacent to the transparent window and the fluorophores 62 have been excited, the emitted signal from the fluorophores 62 is relatively low or absent, and the amount of target component 61 can be determined.

[0228] The emitter-reader assembly shown in FIG. 9 is comprises a casing 90 comprising a plurality of not shown diodes with respective center wavelengths for exciting the respective wavelengths of the fluorophores. The emitter-reader assembly further comprises an emitter fiber bundle 91 comprising a plurality of optical fibers in light connection with the respective diodes for guiding the light towards not shown fluorophores bound to temporarily immobilized magnetic particles in a micro fluidic device. The emitter fiber bundle 91 has a length section 92 adjacent to emitter output ends 93 of the optical fibers from where the light 99 is emitted.

[0229] In the length section 92 the emitter bundle 91 is merged with a reader fiber bundle 96 such that the length section is a common emitter-reader length section 92. The common emitter-reader length section 92 is held together by a sleeve 94. The reader fiber bundle 96 comprises a plurality of optical fibers having reader input ends 95 arranged to receive the light signal 99 from the fluorophores. The reader fiber bundle 96 is fixed to a connector 97 where it is connected to a not shown reading unit - e.g. a spectroscope, via a waveguide 98 e.g. in form of another fiber bundle.

[0230] The emitter output ends 93 and the reader input ends 95 are advantageously arranged in a predetermined pattern. The predetermined pattern is advantageously selected such as to obtain high exciting rate and high reading rate. The emitter output ends 93 and the reader input ends 95 are advantageously positioned immediately adjacent to the transparent window, e.g. where the magnet was arranged when immobilizing the magnetic particles and/ or immediately adjacent to the magnet.

Examples

Example 1

Screening tests

[0231] Milk samples are screened for the target analyte Ampecillin.

[0232] A system as shown in FIG. 5 is used. The micro fluidic device is in the form of a cartridge similar to the

micro fluidic device of FIG. 4, but with the difference that the 5 flow channels each have their respective inlet with an inlet-well.

[0233] The magnet applied is a permanent magnet arranged to immobilize magnetic particles in the reading zone.

[0234] The channels are in fluid connection to sink sections 4 and have together with the sink section 5 zones, an inlet zone 0, a zone with temporally immobilized magnetic particles 1, a zone with temporally immobilized fluorophores 2, a reading zone with a transparent window 3 and a zone with flexible wall and sink sections 4.

[0235] By having 5 separate flow channels with separate inlets it is possible to screen 5 different samples simultaneously.

[0236] The temporally immobilized magnetic particles are 1.5 μm Biomag Protein G magnetic particles from Qiagen with Ampicillin antibody loaded onto Protein G. 1 μL of 0.4% by weight of the magnetic particles solution in buffer is deposited in the channel (zone 1) and dried down.

[0237] The temporally immobilized fluorophores are Qdot 655 Biotin Conjugate from Invitrogen loaded with Ampicillin. 1 μL of 15 nM buffer solution of the Qdot 655 is deposited in the channel (zone 2) and dried down.

[0238] As an internal reference signal Bio-Adembeads Streptavidin magnetic beads from Ademtech are labeled with Qdot 605 biotin conjugate from Invitrogen. The Bio-Adembeads Streptavidin magnetic beads are deposited in the fluorophores zone (zone 2).

[0239] The tests are performed as follows:

5 different milk samples are loaded in the 5 inlet-wells on the cartridge. Each sample is drawn into the respective channel of the cartridge and re-suspends the magnetic particle in zone 1. Incubation is done by cycling the flow for 20 seconds over the site comprising the immobilized magnetic particles to re-suspend these and allow the magnetic particles to catch target analytes in the exposed sample volume. The sample is then drawn further into the channels of the cartridge to zone 2 and re-suspends the Qdots. Again incubation is done by cycling the flow for 20 seconds. Finally the sample is drawn into the sink section 4 whereby the magnetic particles approaching the magnet while the sample is passing are immobilized in the reading zone.

[0240] The magnetic particles are subjected to exciting wavelength(s) and the emitted signal is recorded.

[0241] The signals recorded at 655 nm can be normalized with the signal recorded at 605 nm. The resulting signal will show whether the respective sample comprises the target analyte.

Example 2

Quantitative determination of one target analyte

[0242] Mouse serum is tested for Mouse IgG. The samples are prepared by dilution of the Mouse serum in buffer.

[0243] A system as shown in FIG. 5 is used. The micro fluidic device is in the form of a cartridge similar to the micro fluidic device of FIG. 4 but with the difference that the micro fluidic device comprises 2 flow channels with a common inlet with an inlet-well and the micro fluidic device comprises a common sink section in fluid connection with the flow channels. The micro fluidic device further comprises a flexible wall section which is common for the flow channels. In this example it is important that the flow channels and the deposition in the flow channels are essentially identical.

[0244] The magnet applied is a permanent magnet arranged to immobilize magnetic particles in the reading zone.

[0245] The channels in flow connection with the sink sections 4 have 5 zones, a common inlet zone 0, a zone with temporally immobilized fluorophores 1, a zone with temporally immobilized magnetic particles 2, a reading zone with a transparent window 3 and a common zone with flexible wall and sink section 4. It should be observed that the magnetic particles zone and the fluorophores zone in this example are reversed compared to the order thereof in example 1.

[0246] By having 5 separate flow channels with separate inlet it is possible to screen 5 different samples simultaneously.

[0247] The temporally immobilized magnetic particles are 1.5 μm Biomag Protein G magnetic particles from Qiagen with mouse IgG loaded onto Protein G. 1 μL of 0.4% by weight of the magnetic particles solution in buffer is deposited in the channel (zone 2) and dried down.

[0248] The temporally immobilized fluorophores are Qdot 655 Goat F(ab')₂ anti-Mouse IgG Conjugate (H+L) from Invitrogen. 1 μL of 15 nM buffer solution of the Qdot 655 is deposited in the channel (zone 1) and dried down.

[0249] Additionally a surfactant in the form of a detergent is applied in the sink section.

[0250] The tests are performed as follows:

Sample is applied in the well and drawn into the channels of the cartridge and re-suspends Qdots in zone 1. Incubation is done by cycling the flow for 20 seconds over the site for the immobilized Qdots to re-suspend these. The sample is then drawn further into the channels of the cartridge and re-suspends the immobilized magnetic particles in zone 2 and simultaneously the magnetic particles will catch analytes and Qdots. The analytes and Qdots will compete about the capture sites of the magnetic particles. Again incubation is done by cycling the flow for 20 seconds. Finally the sample is drawn into the sink

section whereby the magnetic particles approaching the magnet while the sample is passing are immobilized in the reading zone. In the sink section the dried down detergent is dissolved and thereby the surface tension of the sample is lowered. To reduce background noise, the sample is finally pushed back into the channels where it is flushing the reading zone of non-immobilized sample but leaving the magnetic particles with the signal at the reading site. The detergent improves the flushing of the fluidic system.

[0251] The magnetic particles are subjected to exciting wavelength(s) and the emitted signal is recorded.

[0252] By comparing the obtained signals by a reference schedule as described above, e.g. a calibration curve, the quantitative determination can be obtained.

Example 3

Quantitative determination of two target analytes

[0253] Milk sample tested for the target analyte Ampicillin and the target analyte Tetracyclin.

[0254] A system as shown in FIG. 5 is used. The micro fluidic device is in the form of a cartridge similar to the micro fluidic device of FIG. 4 but with the difference that the micro fluidic device comprises 2 flow channels with a common inlet with an inlet-well, a common flexible wall section and in fluid connection with a common sink section. In this example it is desired that the flow channels and the deposition in the flow channels are essentially identical for improved precision.

[0255] The magnet applied is a permanent magnet arranged to immobilize magnetic particles in the reading zone.

[0256] The channels in fluid connection with the sink section 4 have 5 zones, a common inlet zone 0, a zone with temporally immobilized magnetic particles 1, a zone with temporally immobilized fluorophores 2, a reading zone with a transparent window 3 and a common zone with flexible wall and sink 4.

[0257] The temporally immobilized magnetic particles are 1.5 μm Biomag Protein G magnetic particles from Qiagen with Ampicillin antibody loaded onto Protein G and 1.5 μm Biomag Protein G magnetic particles from Qiagen with Tetracyclin antibody loaded onto Protein G. 1 μL of 0.2% by weight of each of the magnetic particles solution in buffer is deposited in the channel (zone 1) and dried down.

[0258] The temporally immobilized fluorophores are Qdot 655 Biotin Conjugate from Invitrogen loaded with Ampicillin and Qdot 605 Biotin Conjugate from Invitrogen loaded with Tetracyclin. 1 μL 7.5 nM buffer solutions of both Qdots are deposited in the channel (zone 2) and dried down.

[0259] The tests are performed as follows:

Sample is applied in the well and drawn into channels

of the cartridge and re-suspends magnetic beads in zone 1. Incubation is done by cycling the flow for 20 seconds over the site for the immobilized magnetic particles to re-suspend these and allow the magnetic particles to catch target analytes in the exposed sample volume. The sample is then drawn further into the channels of the cartridge and re-suspends the Qdots in zone 2. Again incubation is done by cycling the flow for 20 seconds. Finally the sample is drawn into the sink section whereby the magnetic particles approaching the magnet while the sample is passing are immobilized in the reading zone. The magnetic particles are subjected to exciting wavelength(s) and the emitted signal is recorded.

[0260] The recorded signal at 655 nm is related to the content of Ampicillin in the sample. The recorded signal at 605 nm is related to the content of Tetracyclin in the sample.

Example 4

Quantitative determination of one target analyte in whole blood

[0261] Whole blood is tested for CRP. The sample is undiluted.

[0262] A system as shown in FIG. 5 is used. The micro fluidic device is in the form of a cartridge similar to the micro fluidic device of FIG. 4 but with the difference that the micro fluidic device comprises 2 flow channels with a common inlet with an inlet-well and with a common flexible wall section and in fluid communication with a common sink section. In this example it is important that the flow channels and the deposition in the flow channels are essentially identical.

[0263] The magnet applied is a permanent magnet arranged to immobilize magnetic particles in the reading zone.

[0264] The channels in fluid connection with a sink section 4 have 5 zones, a common inlet zone 0, a zone with temporally immobilized fluorophores 1, a zone with temporally immobilized magnetic particles 2, a reading zone with a transparent window 3 and a common zone with flexible wall and sink section 4. By having 5 separate flow channels with separate inlets it is possible to screen 5 different samples simultaneously.

[0265] The temporally immobilized magnetic particles are 1.5 μm Biomag Protein G magnetic particles from Qiagen with CPR loaded onto Protein G. 1 μL of 0.4% by weight of the magnetic particles solution in buffer is deposited in the channel (zone 2) and dried down.

[0266] The temporally immobilized fluorophores are Qdot 655 Biotin Conjugate from Invitrogen loaded with CRP antibody. 1 μL of 15 nM buffer solution of the Qdot 655 is deposited in the channel (zone 1) and dried down.

[0267] The tests are performed as follows:

Sample is applied in the well and is drawn into cartridge and re-suspends Qdots in zone 1. Incubation is done by cycling the flow for 40 seconds over the site for the immobilized Qdots. The sample is then drawn further into channels of the cartridge and re-suspends the immobilized magnetic beads and simultaneously the magnetic particles will catch analytes and Qdots. The analytes and Qdots will compete about the capture sites of the magnetic particles. Again incubation is done by cycling the flow for 40 seconds. Finally, the sample is drawn into the sink section whereby the magnetic particles approaching the magnet while the sample is passing are immobilized in the reading zone.

[0268] The magnetic particles are subjected to exciting wavelength(s) and the emitted signal is recorded.

[0269] By comparing the obtained signals by a reference schedule as described above, e.g. a calibration curve, the quantitative determination can be obtained.

Example 5

[0270] Example 1 is repeated using an extract of crushed beef diluted with water. Samples with different degree of dilution are applied.

Example 6

[0271] Example 2 is repeated with the difference that the sample is mixed with the magnetic particles and the fluorophores before applying the sample to the well and drawing it into the channels of the cartridge.

[0272] The mouse serum is diluted in a buffer and mixed with magnetic particle solution and q-dot solution in a vial and is incubated for 5 minutes prior to application in the well and introduction into the channels.

[0273] The sample can immediately be drawn into the sink section whereby the magnetic particles approaching the magnet while the sample is passing are immobilized in the reading zone.

Example 7

[0274] Example 2 is repeated with the difference that the system is flushed with the sample by pushing the sample from the sink section into the channels to flush the reading zone from non-immobilized sample but leaving the magnetic particles with the signal at the reading site.

[0275] When the system has been flushed, a read-out module is positioned above one channel. The Qdots are excited using a 420 LED and the emitted spectrum is recorded. An algorithm running on a PC finds and records the peak light intensity at 655 nm and 605 nm. The read-out module is then positioned above the next channel.

[0276] Some preferred embodiments have been shown in the foregoing, but it should be stressed that the

invention is not limited to these, but may be embodied in other ways within the subject-matter defined in the following claims.

5

Claims

1. A method for quantitative or qualitative determination of a target component, such as a biomolecule in a liquid sample, the method comprises providing a plurality of magnetic particles (17, 54, 64) comprising one or more capture sites (55, 56) for the target component (51, 61) on their respective surfaces;
 - 15 providing a plurality of fluorophores (18, 52, 62) configured to bind to said capture sites (55, 66) of the magnetic particles (17, 54, 64);
 - arranging said fluorophores (18, 52, 62) and said magnetic particles (17, 54, 64) at a distance from each other in a flow channel (11, 21) of a micro fluidic device (31) and downstream from an inlet (13, 23) to the flow channel (11, 21);
 - 20 feeding the liquid sample, into said flow channel (11, 21) via said inlet (13, 23) and mixing it with said fluorophores (18, 52, 62) and said magnetic particles (17, 54, 64); and
 - at least temporarily immobilizing said magnetic particles (17, 54, 64) adjacent to a transparent window of the flow channel (11, 21) using a magnet (33), emitting exciting electromagnetic beam (38a) towards said immobilized magnetic particles (17, 54, 64), reading signals (39a) emitted from fluorophores (18, 52, 62) captured by said immobilized magnetic particles (17, 54, 64) and performing a quantitative or qualitative determination of said target component (51, 61) based on the read signals (39a), preferably the liquid sample comprises a biological fluid or a fraction of a biological fluid, such as human or animal or vegetable fluids for example blood, saliva, urine, milk, cytosol (intracellular fluid), interstitial fluid (tissue fluid) and/or one or more fractions and/or mixtures thereof, and/or suspended biological solids, such as tissue or solid food e.g. meat or vegetable.
2. The method of claim 1, wherein the target component comprises a microorganism such as at least one of bacterial, viral, or fungal pathogens, e.g. E. coli E. coli, Citrobacter spp, Aeromonas spp., Pasteurella spp., non-serogroup DI Salmonella, Campylobacter Staphylococcus spp. and combinations thereof and/or the target component comprises a cell, such as a blood cell, a stem cell or a tumor cell and/or the target component comprises proteins, nucleotides, carbohydrates, or lipids, in particular an enzyme, an antigen or an antibody.
3. The method of any of the preceding claims, wherein capture sites (55, 66) are specific for said target com-

- ponent (51, 61) or specific for a group of components comprising one or more target components (51, 61).
4. The method of any of the preceding claims, wherein the magnetic particles are coated magnetic particles comprising a coating comprising the captures sites, wherein the capture sites are selected to be capture sites for the target component, the coating for example comprises the capture sites in the form of antigen, antibody, avidine, biotin or Goat anti-Mouse IgG.
 5. The method of any of the preceding claims, wherein the fluorophores are quantum dots or aromatic probes and/or conjugated probes, preferably the fluorophores are configured to bind to said capture sites of the magnetic particles by being coupled to a component which can bind to the capture sites of the magnetic particles, the component is preferably identical or homolog to said target component.
 6. The method of any of the preceding claims, wherein the fluorophores are quantum dots that emit one or more discrete frequencies of light when stimulated by a light source, wherein each quantum dot comprises a core of an excitable material, such as a semiconductor nanoparticle or a rare earth doped oxide colloidal nanoparticle, preferably the quantum dots each comprise a core with a size of up to about 25 nm, such as from 2-10 nm, the quantum dots preferably comprise an organic coating, such as a polymer coating, the coating is coupled to a component which can bind to the capture sites of the magnetic particles.
 7. The method of claim 6, wherein said fluorophores (18, 52, 62) and said magnetic particles (17, 54, 64) are temporally immobilized in said flow channel (11, 21) of the micro fluidic device (31) such that they cannot bind to each other prior to the feeding of said liquid sample to said flow channel (11, 21).
 8. The method of any of the preceding claims, wherein the method comprises allowing the capture sites of the magnetic particles (17, 54, 64) to capture possible target component in the liquid sample and/or fluorophores (18, 52, 62), the method preferably comprises pulsating said liquid sample in said flow channel optionally using an actuator, where after the magnetic particles (17, 54, 64) are at least temporally immobilized adjacent to said transparent window using a magnet.
 9. The method of any of the preceding claims, wherein said at least temporally immobilized magnetic particles (17, 54, 64) are subjected to said electromagnetic beam (38a) such that at least a part of possible fluorophores (18, 52, 62) captured by said capture sites (55, 65) of the magnetic particles (17, 54, 64) are excited, where after the emitted signal (39a) from any captured fluorophores (18, 52, 62) is read and a quantitative or qualitative determination of said target component (51, 61) based on the read signal (30a) is performed, preferably said at least temporally immobilized magnetic particles (17, 54, 64) are released from magnetic forces applied by the magnet (33) prior to being subjected to said electromagnetic beam (38a).
 10. The method of any of the preceding claims, wherein said method comprises performing two or more parallel assays on the liquid sample for quantitative or qualitative determination of the target component(s), each assay comprises:
 - bringing a part of the liquid sample into contact with said fluorophores (18, 52, 62) and said magnetic particles (17, 54, 64) in a micro fluidic device (31) comprising a transparent window; and
 - at least temporally immobilizing said magnetic particles (17, 54, 64) adjacent to said transparent window using a magnet (33), emitting exciting electromagnetic beam (38a) towards said immobilized magnetic particles (17, 54, 64), and reading signals (38b) emitted from fluorophores (18, 52, 62) captured by said immobilized magnetic particles (17, 54, 64),
 preferably the fluorophores and/or the magnetic particles used in one of the two or more parallel assays differ from the fluorophores and/or the magnetic particles used in another one of the two or more parallel assays, preferably the fluorophores and/or the magnetic particles used in one of the two or more parallel assays differ from the fluorophores and/or the magnetic particles used in another one of the two or more parallel assays with respect to type, size, coating, shape and/or amount.
 11. The method of any of the preceding claims, wherein the quantitative or qualitative determination of target component(s) (51, 61) in a liquid sample is performed by comparing the read signal(s) with signals obtained from liquid samples of known composition and/or by multiplexing the read signal(s) from different groups of fluorophores e.g. from the same assay optionally using reference fluorophores with a different exciting wavelength, from fluorophores from parallel assays and/or from fluorophores in reference tests of known or unknown liquid samples.
 12. A micro fluidic device for use in preparing a liquid sample for optical analysis for quantitative or qualitative determination of a of target component (51, 61) in the sample, the micro fluidic device (31) comprising at least one flow channel (11, 21) with a transparent window and an inlet (13, 23) for the liquid

sample, **characterized in that** the micro fluidic device (31) further comprises in its flow channel (11, 21)

- a plurality of magnetic particles (17, 54, 64) comprising capture sites (55, 65) for the target component (51, 61) on their surfaces; and
- a plurality of fluorophores (18, 52, 62) configured to bind the capture sites (55, 65) of the magnetic particles (17, 54, 64),

wherein said fluorophores (18, 52, 62) and said magnetic particles (17, 54, 64) are arranged downstream to said inlet (13, 23) and at a distance from each other in said flow channel (11, 21), such that upon feeding the liquid sample into the flow channel (11, 21) via said inlet (13, 23), said liquid sample is mixed with said magnetic particles (17, 54, 64) and said fluorophores (18, 52, 62).

13. A system for quantitative or qualitative determination of a target component (51, 61) in a liquid sample, the system comprises

- the micro fluidic device (31) according to claim 12;
- a magnet (33) arranged to at least temporarily immobilize said magnetic particles (17, 54, 64) adjacent to said transparent window;
- an emitter (38) for exciting said fluorophores (18, 52, 62), and
- a reader (39), for reading signals emitted from said fluorophores (18, 52, 62).

14. The system of claim 13, wherein the micro fluidic device (31) is of polymer and/or glass. and the micro fluidic device (31) comprises a substrate 12, 22) with a groove for the flow channel (11, 21) and a foil (11a) covering the flow channel (11, 21) and the micro fluidic device (31) comprises an inlet (13, 23) for suction in the liquid sample, preferably the micro fluidic device (31) comprises a flexible wall section (15) of the flow channel (11, 21) or a sink section (14, 24) in fluid connection with the flow channel (11, 21), the system preferably comprises an actuator, preferably the actuator is arranged to move the flexible wall section, the actuator optionally being a step motor driven actuator.

15. The system of claim 14, wherein the flow channel (11, 21) being in fluid communication with a sink section (14, 24) of the micro fluidic device preferably the micro fluidic device (31) comprises an excitation and read out zone referred to as a reading zone (16, 26) in the form of the transparent window, the window is transparent for at least the exciting and emitting wavelengths of the fluorophores (18, 52, 62).

16. The system of any of claims 13-15 wherein the sys-

tem comprises a temperature regulator for regulating the temperature of the liquid sample in the flow channel, the temperature regulator optionally comprises a peltier element, a thin film heating element and/or other resistive heating elements.

17. The system of any of claims 13-16, wherein the magnetic particles (17, 54, 64) are coated magnetic particles comprising a coating comprising the captures sites, preferably the fluorophores are quantum dots or aromatic probes and/or conjugated probes, the fluorophores are preferably quantum dots, more preferably the fluorophores are configured to bind to said capture sites of the magnetic particles by being coupled to a component which can bind to the capture sites of the magnetic particles, the component is preferably identical or homolog to said target component.

18. The system of any of claims 13-17 wherein said emitter comprises at least one optical fiber (91) with an output end (93) for emitting said electromagnetic radiation and said reader comprises at least one optical fiber (96) with an input end (95) for receiving said signals emitted from fluorophores (18, 52, 62) captured by magnetic particles (17, 54, 64), preferably said optical fiber (91) of the emitter and said optical fiber (96) of the reader are arranged adjacent to each other in at least respective length sections (92) adjacent to respectively the output end (93) and the input end (95), preferably said emitter comprises a plurality of optical fibers (91), each with an output end (93) for emitting said electromagnetic radiation and said reader comprises a plurality of optical fibers (96), each with an input end (95) for receiving said signals emitted from fluorophores (18, 52, 62) captured by magnetic particles, preferably said optical fibers (91) of the emitter and said optical fibers (96) of the reader are arranged adjacent to each other in at least respective length sections (92) adjacent to respectively the output end and the input, more preferably the output ends and the input ends are arranged in a predetermined pattern.

19. The system of any of claims 13-18, wherein said system comprises a signal processor comprising a computer for performing the quantitative or qualitative determination of target component(s) in a liquid sample based on the read signal(s), wherein the signal processor is configured to multiplex signals from different groups of fluorophores, from fluorophores from parallel assays and/or from fluorophores in reference tests of known or unknown liquid samples, preferably the signal processor is configured to multiplex signals from different groups of fluorophores applied in the same assay.

20. A micro fluidic device of claim 12, wherein the device

comprises a substrate (12, 22) with a groove for the flow channel (11, 21) and a foil (11a) covering the flow channel (11, 21), the flow channel (11, 21) comprises the transparent window and the inlet (13, 23) for suction in the liquid sample, the micro fluidic device (31) comprises a flexible wall section (15) of the flow channel (11, 21) or of a sink section (14, 24) in fluid connection with the flow channel (11, 21), the flexible wall section (15) can be moved such that air will be pressed out of the flow channel (11, 21) where after the flexible wall (15) will return to its initial position, preferably the flow channel (11, 21) being in fluid communication with a sink section (14, 24) of the micro fluidic device (31).

Patentansprüche

1. Verfahren zur quantitativen oder qualitativen Bestimmung einer Zielkomponente, wie etwa eines Biomoleküls in einer flüssigen Probe, wobei das Verfahren umfasst:

Bereitstellen einer Vielzahl von magnetischen Partikeln (17, 54, 64), die eine oder mehrere Einfangstellen (55, 56) für die Zielkomponente (51, 61) auf ihren jeweiligen Oberflächen aufweisen; Bereitstellen einer Vielzahl von Fluorophoren (18, 52, 62), die so konfiguriert sind, dass sie an die Einfangstellen (55, 56) der magnetischen Partikel (17, 54, 64) binden;

Anordnen der Fluorophore (18, 52, 62) und der magnetischen Partikel (17, 54, 64) in einem Abstand voneinander in einem Strömungskanal (11, 21) einer Mikrofluidvorrichtung (31) und stromabwärts von einem Einlass (13, 23) in den Strömungskanal (11, 21);

Zuführen der flüssigen Probe in den Strömungskanal (11, 21) über den Einlass (13, 23) und Mischen derselben mit den Fluorophoren (18, 52, 62) und den magnetischen Partikeln (17, 54, 64); und

zumindest zeitweises Immobilisieren der magnetischen Partikel (17, 54, 64) benachbart zu einem transparenten Fenster des Strömungskanals (11, 21) unter Verwendung eines Magneten (33), Emittieren eines anregenden elektromagnetischen Strahls (38a) in Richtung der immobilisierten magnetischen Partikel (17, 54, 64), Auslesen der Signale (39a), die von Fluorophoren (18, 52, 62), emittiert werden, die von immobilisierten magnetischen Partikeln (17, 54, 64) eingefangen wurden, und Durchführen einer quantitativen oder qualitativen Bestimmung der Zielkomponente (51, 61) basierend auf den Lesesignalen (39a), wobei vorzugsweise die flüssige Probe ein biologisches Fluid oder eine Fraktion eines biologischen Fluids auf-

weist, wie etwa menschliche oder tierische oder pflanzliche Fluide, zum Beispiel Blut, Speichel, Urin, Milch, Cytosol (intrazelluläre Flüssigkeit), interstitielle Flüssigkeit (Gewebeblutflussigkeit) und/oder eine oder mehrere Fraktionen und/oder Mischungen davon, und/oder suspendierte biologische Feststoffe, wie etwa Gewebe oder feste Lebensmittel, z. B. Fleisch oder Gemüse.

2. Verfahren nach Anspruch 1, wobei die Zielkomponente einen Mikroorganismus aufweist, wie etwa mindestens eines von bakteriellen, viralen oder Pilz-Pathogenen, z. B. E-coli E. coli, Citrobacter spp, Aeromonas spp., Pasteurella spp., Nicht-Serogruppe D1 Salmonella, Camphylobacter Staphylococcus spp. und Kombinationen davon, und/oder die Zielkomponente eine Zelle aufweist, wie etwa eine Blutzelle, eine Stammzelle oder eine Tumorzelle, und/oder die Zielkomponente Proteine, Nukleotide, Kohlenhydrate oder Lipide, insbesondere ein Enzym, ein Antigen oder einen Antikörper, aufweist.

3. Verfahren nach einem der vorhergehenden Ansprüche, wobei die Einfangstellen (55, 56) für die Zielkomponente (51, 61) spezifisch sind oder für eine Gruppe von Komponenten, die eine oder mehrere Zielkomponenten (51, 61) aufweist, spezifisch sind.

4. Verfahren nach einem der vorhergehenden Ansprüche, wobei die magnetischen Partikel beschichtete magnetische Partikel sind, die eine Beschichtung aufweisen, die die Einfangstellen aufweist, wobei die Einfangstellen als Einfangstellen für die Zielkomponente ausgewählt sind, wobei die Beschichtung beispielsweise die Einfangstellen in Form von Antigenen, Antikörpern, Avidin, Biotin oder Ziege-Anti-Maus-IgG aufweist.

5. Verfahren nach einem der vorhergehenden Ansprüche, wobei die Fluorophore Quantenpunkte oder aromatische Sonden und/oder konjugierte Sonden sind, wobei vorzugsweise die Fluorophore so konfiguriert sind, dass sie an die Einfangstellen der magnetischen Partikel binden, indem sie an eine Komponente gekoppelt werden, die an die Einfangstellen der magnetischen Partikel binden kann, wobei die Komponente vorzugsweise identisch oder homolog zu der Zielkomponente ist.

6. Verfahren nach einem der vorhergehenden Ansprüche, wobei die Fluorophore Quantenpunkte sind, die eine oder mehrere diskrete Lichtfrequenzen emittieren, wenn sie durch eine Lichtquelle stimuliert werden, wobei jeder Quantenpunkt einen Kern aus einem anregbaren Material aufweist, wie etwa einem Halbleiter-Nanopartikel oder einem Seltenerd-dotiertem Oxid-Kolloid-Nanopartikel, wobei vorzugs-

- weise die Quantenpunkte jeweils einen Kern mit einer Größe von bis zu etwa 25 nm, wie etwa 2-10 nm, aufweisen, wobei die Quantenpunkte vorzugsweise eine organische Beschichtung aufweisen, wie etwa eine Polymerbeschichtung, wobei die Beschichtung mit einer Komponente gekoppelt ist, die an die Einfangstellen der magnetischen Partikel binden kann.
7. Verfahren nach Anspruch 6, wobei die Fluorophore (18, 52, 62) und die magnetischen Partikel (17, 54, 64) zeitweise in dem Strömungskanal (11, 21) der Mikrofluidvorrichtung (31) derart immobilisiert sind, dass sie vor dem Zuführen der flüssigen Probe in den Strömungskanal (11, 21) nicht aneinander binden können.
8. Verfahren nach einem der vorhergehenden Ansprüche, wobei das Verfahren das Ermöglichen des Einfangens einer möglichen Zielkomponente in der flüssigen Probe und/oder von Fluorophoren (18, 52, 62) durch die Einfangstellen der magnetischen Partikel (17, 54, 64) umfasst, wobei das Verfahren vorzugsweise das Pulsieren der flüssigen Probe in den Strömungskanal, wahlweise unter Verwendung eines Aktuators, umfasst, wonach die magnetischen Partikel (17, 54, 64) mindestens zeitweise benachbart zu dem transparenten Fenster unter Verwendung eines Magneten immobilisiert werden.
9. Verfahren nach einem der vorhergehenden Ansprüche, wobei die mindestens zeitweise immobilisierten magnetischen Partikel (17, 54, 64) dem elektromagnetischen Strahl (38a) derart ausgesetzt werden, dass mindestens ein Teil möglicher Fluorophore (18, 52, 62), die von den Einfangstellen (55, 65) der magnetischen Partikel (17, 54, 64) eingefangen werden, angeregt werden, wonach das emittierte Signal (39a) von jeglichen eingefangenen Fluorophoren (18, 52, 62) ausgelesen wird und eine quantitative oder qualitative Bestimmung der Zielkomponente (51, 61) basierend auf dem Lesesignal (30a) durchgeführt wird, wobei vorzugsweise die mindestens zeitweise immobilisierten magnetischen Partikel (17, 54, 64) von durch den Magneten (33) angewendeten magnetischen Kräften freigegeben werden, bevor sie dem elektromagnetischen Strahl (38a) ausgesetzt werden.
10. Verfahren nach einem der vorhergehenden Ansprüche, wobei das Verfahren das Durchführen von zwei oder mehr parallelen Assays an der flüssigen Probe zur quantitativen oder qualitativen Bestimmung der Zielkomponente(n) umfasst, wobei jeder Assay umfasst:
- Inkontaktbringen eines Teils der flüssigen Probe mit den Fluorophoren (18, 52, 62) und den magnetischen Partikeln (17, 54, 64) in einer Mikrofluidvorrichtung (31), die ein transparentes Fenster aufweist; und
 - mindestens zeitweises Immobilisieren der magnetischen Partikel (17, 54, 64) benachbart zum transparentem Fenster unter Verwendung eines Magneten (33), Emittieren eines anregenden elektromagnetischen Strahls (38a) in Richtung der immobilisierten magnetischen Partikel (17, 54, 64), und Auslesen von Signalen (38b), die von Fluorophoren (18, 52, 62) emittiert werden, die von den immobilisierten magnetischen Partikeln (17, 54, 64) eingefangen wurden,
- wobei sich vorzugsweise die Fluorophore und/oder die magnetischen Partikel, die in einem der zwei oder mehr parallelen Assays verwendet werden, von den Fluorophoren und/oder den magnetischen Partikeln, die in einem weiteren der zwei oder mehr parallelen Assays verwendet werden, unterscheiden, wobei sich vorzugsweise die Fluorophore und/oder die magnetischen Partikel, die in einem der zwei oder mehr parallelen Assays verwendet werden, von den Fluorophoren und/oder den magnetischen Partikeln, die in einem weiteren der zwei oder mehr parallelen Assays verwendet werden, in Bezug auf Art, Größe, Beschichtung, Form und/oder Menge unterscheiden.
11. Verfahren nach einem der vorhergehenden Ansprüche, wobei die quantitative oder qualitative Bestimmung der Zielkomponente(n) (51, 61) in einer flüssigen Probe durchgeführt wird, indem das/die Lesesignal/e mit Signalen verglichen werden, die aus flüssigen Proben von bekannter Zusammensetzung erhalten werden, und/oder durch Multiplexen des/der Lesesignals/e aus verschiedenen Gruppen von Fluorophoren, z. B. aus dem gleichen Assay, gegebenenfalls unter Verwendung von Referenzfluorophoren mit einer anderen Anregungswellenlänge, von Fluorophoren aus parallelen Assays und/oder von Fluorophoren in Referenztests bekannter oder unbekannter flüssiger Proben.
12. Mikrofluidvorrichtung zur Verwendung bei der Herstellung einer flüssigen Probe zur optischen Analyse zur quantitativen oder qualitativen Bestimmung einer Zielkomponente (51, 61) in der Probe, wobei die Mikrofluidvorrichtung (31) mindestens einen Strömungskanal (11, 21) mit einem transparenten Fenster und einen Einlass (13, 23) für die flüssige Probe aufweist, **dadurch gekennzeichnet, dass** die Mikrofluidvorrichtung (31) ferner in ihrem Strömungskanal (11, 21)
- eine Vielzahl von magnetischen Partikeln (17, 54, 64), die Einfangstellen (55, 65) für die Zielkomponente (51, 61) auf ihren Oberflächen aufweisen; und

- eine Vielzahl von Fluorophoren (18, 52, 62) aufweist, die so konfiguriert sind, dass sie die Einfangstellen (55, 65) der magnetischen Partikel (17, 54, 64) binden,

wobei die Fluorophore (18, 52, 62) und die magnetischen Partikel (17, 54, 64) stromabwärts vom Einlass (13, 23) und in einem Abstand voneinander in dem Strömungskanal (11, 21) angeordnet sind, so dass die flüssige Probe nach Zuführung der flüssigen Probe in den Strömungskanal (11, 21) über den Einlass (13, 23) mit den magnetischen Partikeln (17, 54, 64) und den Fluorophoren (18, 52, 62) gemischt wird.

13. System zur quantitativen oder qualitativen Bestimmung einer Zielkomponente (51, 61) in einer flüssigen Probe, wobei das System die Mikrofluidvorrichtung (31) nach Anspruch 12; einen Magneten (33), der so angeordnet ist, dass er mindestens zeitweise die magnetischen Partikel (17, 54, 64) benachbart zum transparenten Fenster immobilisiert; einen Emmitter (38) zum Anregen der Fluorophore (18, 52, 62), und einen Leser (39) zum Auslesen von von den Fluorophoren (18, 52, 62) emittierten Signalen aufweist.
14. System nach Anspruch 13, wobei die Mikrofluidvorrichtung (31) aus Polymer und/oder Glas besteht, und die Mikrofluidvorrichtung (31) ein Substrat (12, 22) mit einer Nut für den Strömungskanal (11, 21) und eine den Strömungskanal (11, 21) abdeckende Folie (11a) aufweist, und die Mikrofluidvorrichtung (31) einen Einlass (13, 23) zum Einsaugen der flüssigen Probe aufweist, wobei vorzugsweise die Mikrofluidvorrichtung (31) einen flexiblen Wandabschnitt (15) des Strömungskanals (11, 21) oder einen mit dem Strömungskanal (11, 21) in Fluidverbindung stehenden Senkabschnitt (14, 24) aufweist, wobei das System vorzugsweise einen Aktuator aufweist, wobei vorzugsweise der Aktuator angeordnet ist, um den flexiblen Wandabschnitt zu bewegen, wobei der Aktuator optional ein durch einen Schrittmotor angetriebener Aktuator ist.
15. System nach Anspruch 14, wobei der Strömungskanal (11, 21) mit einem Senkabschnitt (14, 24) der Mikrofluidvorrichtung in Fluidverbindung steht, wobei vorzugsweise die Mikrofluidvorrichtung (31) eine Anregungs- und eine als Auslesezone (16, 26) bezeichnete Auslesezone in Form des transparenten Fensters aufweist, wobei das Fenster für mindestens die anregenden und emittierenden Wellenlängen der Fluorophore (18, 52, 62) transparent ist.
16. System nach einem der Ansprüche 13 bis 15, wobei das System einen Temperaturregler zur Regelung

der Temperatur der flüssigen Probe im Strömungskanal aufweist, wobei der Temperaturregler optional ein Peltierelement, ein Dünnschichtheizelement und/oder andere Widerstandsheizelemente aufweist.

5

10

15

20

25

30

35

40

45

50

55

17. System nach einem der Ansprüche 13 bis 16, wobei die magnetischen Partikel (17, 54, 64) beschichtete magnetische Partikel sind, die eine Beschichtung aufweisen, die die Einfangstellen aufweist, wobei vorzugsweise die Fluorophore Quantenpunkte oder aromatische Sonden und/oder konjugierte Sonden sind, wobei die Fluorophore vorzugsweise Quantenpunkte sind, wobei bevorzugter die Fluorophore so konfiguriert sind, dass sie an die Einfangstellen der magnetischen Partikel binden, indem sie an eine Komponente gekoppelt sind, die an die Einfangstellen der magnetischen Partikel binden kann, wobei die Komponente vorzugsweise identisch oder homolog zu der Zielkomponente ist.
18. System nach einem der Ansprüche 13 bis 17, wobei der Emmitter mindestens eine optische Faser (91) mit einem Ausgangsende (93) zum Emittieren der elektromagnetischen Strahlung aufweist, und der Leser mindestens eine optische Faser (96) mit einem Eingangsende (95) zum Empfangen der von den von magnetischen Partikeln (17, 54, 64) eingefangenen Fluorophoren (18, 52, 62) emittierten Signale aufweist, wobei vorzugsweise die optische Faser (91) des Emitters und die optische Faser (96) des Lesers in mindestens den jeweiligen Längsabschnitten (92) benachbart jeweils zum Ausgangsende (93) und zum Eingangsende (95) benachbart zueinander angeordnet sind, wobei der Emmitter vorzugsweise eine Vielzahl von optischen Fasern (91) aufweist, jeweils mit einem Ausgangsende (93) zum Emittieren der elektromagnetischen Strahlung, und der Leser eine Vielzahl von optischen Fasern (96) aufweist, jeweils mit einem Eingangsende (95) zum Empfangen der von den von magnetischen Partikeln eingefangenen Fluorophoren (18, 52, 62) emittierten Signale, wobei vorzugsweise die optischen Fasern (91) des Emitters und die optischen Fasern (96) des Lesers in mindestens den jeweiligen Längsabschnitten (92) benachbart jeweils zum Ausgangsende und zum Eingangsende benachbart zueinander angeordnet sind, wobei vorzugsweise die Ausgangsenden und die Eingangsenden in einem vorbestimmten Muster angeordnet sind.
19. System nach einem der Ansprüche 13 bis 18, wobei das System einen Signalprozessor aufweist, der einen Computer zum Durchführen der quantitativen oder qualitativen Bestimmung der Zielkomponente(n) in einer flüssigen Probe basierend auf dem/den Lesesignal/en aufweist, wobei der Signalprozessor zum Multiplexen von Signalen aus verschiedenen

Gruppen von Fluorophoren, von Fluorophoren aus parallelen Assays und/oder von Fluorophoren in Referenztests bekannter oder unbekannter flüssiger Proben konfiguriert ist, wobei vorzugsweise der Signalprozessor zum Multiplexen von Signalen aus verschiedenen Gruppen von Fluorophoren, die in dem gleichen Test verwendet werden, konfiguriert ist.

20. Mikrofluidvorrichtung nach Anspruch 12, wobei die Vorrichtung ein Substrat (12, 22) mit einer Nut für den Strömungskanal (11, 21) und eine den Strömungskanal (11, 21) abdeckende Folie (11a) aufweist, der Strömungskanal (11, 21) das transparente Fenster und den Einlass (13, 23) zum Einsaugen der flüssigen Probe aufweist, wobei die Mikrofluidvorrichtung (31) einen flexiblen Wandabschnitt (15) des Strömungskanals (11, 21) oder eines mit dem Strömungskanal (11, 21) in Fluidverbindung stehenden Senkabschnitts (14, 24) aufweist, wobei der flexible Wandabschnitt (15) derart bewegt werden kann, dass Luft aus dem Strömungskanal (11, 21) herausgedrückt wird, wonach die flexible Wand (15) in ihre Ausgangsposition zurückkehrt, wobei vorzugsweise der Strömungskanal (11, 21) mit einem Senkabschnitt (14, 24) der Mikrofluidvorrichtung (31) in Fluidverbindung steht.

Revendications

1. Procédé de détermination quantitative ou qualitative d'un composant cible, comme une biomolécule dans un échantillon liquide, le procédé comprenant :

la fourniture d'une pluralité de particules magnétiques (17, 54, 64) comprenant un ou plusieurs sites de capture (55, 56) pour le composant cible (51, 61) sur leurs surfaces respectives ;

la fourniture d'une pluralité de fluorophores (18, 52, 62) configurés pour se lier aux dits sites de capture (55, 66) des particules magnétiques (17, 54, 64) ;

l'agencement desdits fluorophores (18, 52, 62) et desdites particules magnétiques (17, 54, 64) à une distance l'un de l'autre dans un canal d'écoulement (11, 21) d'un dispositif microfluidique (31) et en aval d'une entrée (13, 23) au canal d'écoulement (11, 21) ;

l'alimentation de l'échantillon liquide dans ledit canal d'écoulement (11, 21) par l'intermédiaire de ladite entrée (13, 23) et le mélange de celui-ci aux dits fluorophores (18, 52, 62) et aux dites particules magnétiques (17, 54, 64) ; et
l'immobilisation au moins provisoire desdites particules magnétiques (17, 54, 64) adjacentes à une fenêtre transparente du canal d'écoulement (11, 21) en utilisant un aimant (33), l'émission

d'un faisceau électromagnétique excitant (38a) vers lesdites particules magnétiques immobilisées (17, 54, 64), la lecture de signaux (39a) émis depuis des fluorophores (18, 52, 62) capturés par lesdites particules magnétiques immobilisées (17, 54, 64) et l'exécution d'une détermination quantitative ou qualitative dudit composant cible (51, 61) sur la base des signaux lus (39a), de préférence

l'échantillon liquide comprend un fluide biologique ou une fraction d'un fluide biologique, comme des fluides humains ou animaux ou végétaux, par exemple du sang, de la salive, de l'urine, du lait, du cytosol (fluide intracellulaire), du fluide interstitiel (fluide de tissu) et/ou une ou plusieurs fractions et/ou des mélanges de ceux-ci, et/ou des solides biologiques en suspension, comme un tissu ou un aliment solide, par exemple de la viande ou un légume.

2. Procédé selon la revendication 1, dans lequel le composant cible comprend un micro-organisme comme au moins l'un de pathogènes bactériens, viraux ou fongiques, par exemple E-coli E. coli, Citrobacter spp, Aeromonas spp., Pasteurella spp., Salmonelle DI non-sérogroupe, Camphylobacter Staphylococcus spp et des combinaisons de ceux-ci et/ou le composant cible comprend une cellule, comme une cellule sanguine, une cellule souche ou une cellule de tumeur et/ou le composant cible comprend des protéines, des nucléotides, des carbohydrates ou des liquides, en particulier une enzyme, un antigène ou un anticorps.

3. Procédé selon l'une quelconque des revendications précédentes, dans lequel des sites de capture (55, 66) sont spécifiques au dit composant cible (51, 61) ou spécifiques à un groupe de composants comprenant un ou plusieurs composants cibles (51, 61).

4. Procédé selon l'une quelconque des revendications précédentes, dans lequel les particules magnétiques sont des particules magnétiques enduites comprenant un enduit comprenant les sites de capture, dans lequel les sites de capture sont sélectionnés pour être des sites de capture pour le composant cible, l'enduit comprenant par exemple les sites de capture sous la forme d'antigène, d'anticorps, d'avidine, de biotine ou de chèvre anti-souris IgC.

5. Procédé selon l'une quelconque des revendications précédentes, dans lequel les fluorophores sont des points quantiques ou des sondes aromatiques et/ou des sondes conjuguées, de préférence les fluorophores sont configurés pour se lier aux dits sites de capture des particules magnétiques en étant couplés à un composant qui peut se lier aux sites de capture des particules magnétiques, le composant

étant de préférence identique ou homologue au dit composant cible.

6. Procédé selon l'une quelconque des revendications précédentes, dans lequel les fluorophores sont des points quantiques qui émettent une ou plusieurs fréquences discrètes de lumière lorsqu'ils sont stimulés par une source lumineuse, dans lequel chaque point quantique comprend un noyau d'une matière excitable, comme une nanoparticule semiconductrice ou une nanoparticule colloïdale d'oxyde dopée aux terres rares, de préférence chacun des points quantiques comprend un noyau d'une taille jusqu'à environ 25 nm, comme de 2 à 10 nm, les points quantiques comprenant de préférence un enduit organique, comme un enduit polymère, l'enduit étant couplé à un composant qui peut se lier aux sites de capture des particules magnétiques.
7. Procédé selon la revendication 6, dans lequel lesdits fluorophores (18, 52, 62) et lesdites particules magnétiques (17, 54, 64) sont provisoirement immobilisés dans ledit canal d'écoulement (11, 21) du dispositif microfluidique (31) de manière à ne pas pouvoir se lier l'un à l'autre avant l'alimentation dudit échantillon liquide dans ledit canal d'écoulement (11, 21).
8. Procédé selon l'une quelconque des revendications précédentes, dans lequel le procédé comprend l'autorisation aux sites de capture des particules magnétiques (17, 54, 64) de capturer un composant cible possible dans l'échantillon liquide et/ou des fluorophores (18, 52, 62), le procédé comprenant de préférence la pulsation dudit échantillon liquide dans ledit canal d'écoulement facultativement en utilisant un actionneur, après quoi les particules magnétiques (17, 54, 64) étant au moins provisoirement immobilisées adjacentes à ladite fenêtre transparente en utilisant un aimant.
9. Procédé selon l'une quelconque des revendications précédentes, dans lequel lesdites particules magnétiques au moins provisoirement immobilisées (17, 54, 64) sont soumises au dit faisceau électromagnétique (38a) de sorte qu'au moins une partie de fluorophores possibles (18, 52, 62) capturés par lesdits sites de capture (55, 65) des particules magnétiques (17, 54, 64) soient excités, après quoi le signal émis (39a) depuis des fluorophores capturés (18, 52, 62) est lu et une détermination quantitative ou qualitative dudit composant cible (51, 61) sur la base du signal lu (30a) est effectuée, de préférence lesdites particules magnétiques au moins provisoirement immobilisées (17, 54, 64) sont libérées sous l'effet de forces magnétiques appliquées par l'aimant (33) avant d'être soumises au dit faisceau électromagnétique (38a).

10. Procédé selon l'une quelconque des revendications précédentes, dans lequel ledit procédé comprend l'exécution d'au moins deux essais parallèles sur l'échantillon liquide pour une détermination quantitative ou qualitative du ou des composants cibles, chaque essai comprenant :

- la mise d'une partie de l'échantillon liquide en contact avec lesdits fluorophores (18, 52, 62) et lesdites particules magnétiques (17, 54, 64) dans un dispositif microfluidique (31) comprenant une fenêtre transparente ; et
- l'immobilisation au moins provisoire desdites particules magnétiques (17, 54, 64) adjacentes à ladite fenêtre transparente en utilisant un aimant (33), l'émission d'un faisceau électromagnétique excitant (38a) vers lesdites particules magnétiques immobilisées (17, 54, 64) et la lecture de signaux (38b) émis depuis des fluorophores (18, 52, 62) capturés par lesdites particules magnétiques immobilisées (17, 54, 64),

de préférence les fluorophores et/ou les particules magnétiques utilisés dans l'un des au moins deux essais parallèles sont différents des fluorophores et/ou des particules magnétiques utilisés dans un autre des au moins deux essais parallèles, de préférence les fluorophores et/ou les particules magnétiques utilisés dans l'un des au moins deux essais parallèles sont différents des fluorophores et/ou des particules magnétiques utilisés dans un autre des au moins deux essais parallèles en ce qui concerne le type, la taille, l'enduit, la forme et/ou la quantité.

11. Procédé selon l'une quelconque des revendications précédentes, dans lequel la détermination quantitative ou qualitative d'un ou plusieurs composants cibles (51, 61) dans un échantillon liquide est effectuée par la comparaison du ou des signaux lus à des signaux obtenus à partir d'échantillons liquides de composition connue et/ou par le multiplexage du ou des signaux lus à partir de groupes différents de fluorophores, par exemple à partir du même essai, en utilisant facultativement des fluorophores de référence avec une longueur d'onde d'excitation différente, à partir de fluorophores d'essais parallèles et/ou à partir de fluorophores dans des tests de référence d'échantillons liquides connus ou inconnus.
12. Dispositif microfluidique destiné à être utilisé dans la préparation d'un échantillon liquide en vue d'une analyse optique pour une détermination quantitative ou qualitative d'un composant cible (51, 61) dans l'échantillon, le dispositif microfluidique (31) comprenant au moins un canal d'écoulement (11, 21) avec une fenêtre transparente et une entrée (13, 23) pour l'échantillon liquide, **caractérisé en ce que** le dispositif microfluidique (31) comprend en outre dans

son canal d'écoulement (11, 21) :

- une pluralité de particules magnétiques (17, 54, 64) comprenant des sites de capture (55, 65) pour le composant cible (51, 61) sur leurs surfaces ; et
- une pluralité de fluorophores (18, 52, 62) configurés pour se lier aux sites de capture (55, 65) des particules magnétiques (17, 54, 64),

dans lequel lesdits fluorophores (18, 52, 62) et lesdites particules magnétiques (17, 54, 64) sont agencés en aval de ladite entrée (13, 23) et à une distance l'un de l'autre dans ledit canal d'écoulement (11, 21), de sorte que, lors de l'alimentation de l'échantillon liquide dans le canal d'écoulement (11, 21) par l'intermédiaire de ladite entrée (13, 23), ledit échantillon liquide soit mélangé aux dites particules magnétiques (17, 54, 64) et aux dits fluorophores (18, 52, 62).

- 13.** Système de détermination quantitative ou qualitative d'un composant cible (51, 61) dans un échantillon liquide, le système comprenant

- le dispositif microfluidique (31) selon la revendication 12 ;
- un aimant (33) agencé pour immobiliser au moins provisoirement lesdites particules magnétiques (17, 54, 64) adjacentes à ladite fenêtre transparente ;
- un émetteur (38) pour exciter lesdits fluorophores (18, 52, 62), et
- un lecteur (39) pour lire des signaux émis depuis lesdits fluorophores (18, 52, 62).

- 14.** Système selon la revendication 13, dans lequel le dispositif microfluidique (31) est en polymère et/ou en verre, et le dispositif microfluidique (31) comprend un substrat (12, 22) avec une rainure pour le canal d'écoulement (11, 21) et une feuille (11a) recouvrant le canal d'écoulement (11, 21) et le dispositif microfluidique (31) comprend une entrée (13, 23) pour une aspiration dans l'échantillon liquide, de préférence le dispositif microfluidique (31) comprend une section de paroi souple (15) du canal d'écoulement (11, 21) ou une section d'évier (14, 24) en liaison fluide avec le canal d'écoulement (11, 21), le système comprend de préférence un actionneur, l'actionneur est de préférence agencé pour déplacer la section de paroi souple, l'actionneur étant facultativement un actionneur entraîné par un moteur pas à pas.

- 15.** Système selon la revendication 14, dans lequel le canal d'écoulement (11, 21) est en communication fluide avec une section d'évier (14, 24) du dispositif microfluidique, de préférence le dispositif microfluidique (31) comprend une zone d'excitation et de lecture à laquelle il est fait référence en tant que zone

de lecture (16, 26) sous la forme de la fenêtre transparente, la fenêtre étant transparente pendant au moins les longueurs d'onde d'excitation et d'émission des fluorophores (18, 52, 62).

- 16.** Système selon l'une quelconque des revendications 13 à 15, dans lequel le système comprend un régulateur de température pour réguler la température de l'échantillon liquide dans le canal d'écoulement, le régulateur de température comprenant facultativement un élément Peltier, un élément chauffant à film mince et/ou d'autres éléments chauffants résistifs.
- 17.** Système selon l'une quelconque des revendications 13 à 16, dans lequel les particules magnétiques (17, 54, 64) sont des particules magnétiques enduites comprenant un enduit comprenant les sites de capture, de préférence les fluorophores sont des points quantiques ou des sondes aromatiques et/ou des sondes conjuguées, les fluorophores sont de préférence des points quantiques, avec plus de préférence les fluorophores sont configurés pour se lier aux dits sites de capture des particules magnétiques en étant couplés à un composant qui peut se lier aux sites de capture des particules magnétiques, le composant étant de préférence identique ou homologue au dit composant cible.
- 18.** Système selon l'une quelconque des revendications 13 à 17, dans lequel ledit émetteur comprend au moins une fibre optique (91) avec une extrémité de sortie (93) pour émettre ledit rayonnement électromagnétique et ledit lecteur comprend au moins une fibre optique (96) avec une extrémité d'entrée (95) pour recevoir lesdits signaux émis depuis des fluorophores (18, 52, 62) capturés par des particules magnétiques (17, 54, 64), de préférence ladite fibre optique (91) de l'émetteur et ladite fibre optique (96) du lecteur sont agencées adjacentes l'une à l'autre dans au moins des sections de longueurs respectives (92) adjacentes respectivement à l'extrémité de sortie (93) et à l'extrémité d'entrée (95), de préférence ledit émetteur comprend une pluralité de fibres optiques (91), chacune d'elles comportant une extrémité de sortie (93) pour émettre ledit rayonnement électromagnétique et ledit lecteur comprend une pluralité de fibres optiques (96), chacune d'elles comportant une extrémité d'entrée (95) pour recevoir lesdits signaux émis depuis des fluorophores (18, 52, 62) capturés par des particules magnétiques, de préférence lesdites fibres optiques (91) de l'émetteur et lesdites fibres optiques (96) du lecteur sont agencées adjacentes l'une à l'autre dans au moins des sections de longueurs respectives (92) adjacentes respectivement à l'extrémité de sortie et à l'extrémité d'entrée, avec plus de préférence les extrémités de sortie et les extrémités d'entrée sont agencées dans

un motif prédéterminé.

19. Système selon l'une quelconque des revendications 13 à 18, dans lequel ledit système comprend un processeur de signal comprenant un ordinateur pour effectuer la détermination quantitative ou qualitative d'un ou plusieurs composants cibles dans un échantillon liquide sur la base d'un ou plusieurs signaux lus, dans lequel le processeur de signal est configuré pour multiplexer des signaux de différents groupes de fluorophores, de fluorophores d'essais parallèles et/ou de fluorophores dans des tests de référence d'échantillons liquides connus ou inconnus, de préférence le processeur de signal est configuré pour multiplexer des signaux de différents groupes de fluorophores appliqués au même essai.
20. Dispositif microfluidique selon la revendication 12, dans lequel le dispositif comprend un substrat (12, 22) avec une rainure pour le canal d'écoulement (11, 21) et une feuille (11a) recouvrant le canal d'écoulement (11, 21), le canal d'écoulement (11, 21) comprend la fenêtre transparente et l'entrée (13, 23) pour l'aspiration dans l'échantillon liquide, le dispositif microfluidique (31) comprend une section de paroi souple (15) du canal d'écoulement (11, 21) ou d'une section d'évier (14, 24) en liaison fluidique avec le canal d'écoulement (11, 21), la section de paroi souple (15) peut être déplacée de sorte que l'air soit pressé hors du canal d'écoulement (11, 21), après quoi la section de paroi souple (15) reprend sa position initiale, de préférence le canal d'écoulement (11, 21) étant en communication fluidique avec une section d'évier (14, 24) du dispositif microfluidique (31).

40

45

50

55

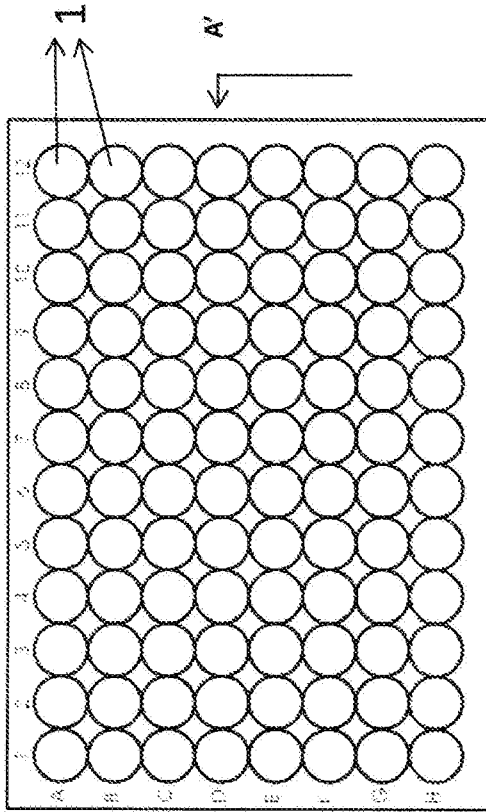

FIG. 1a

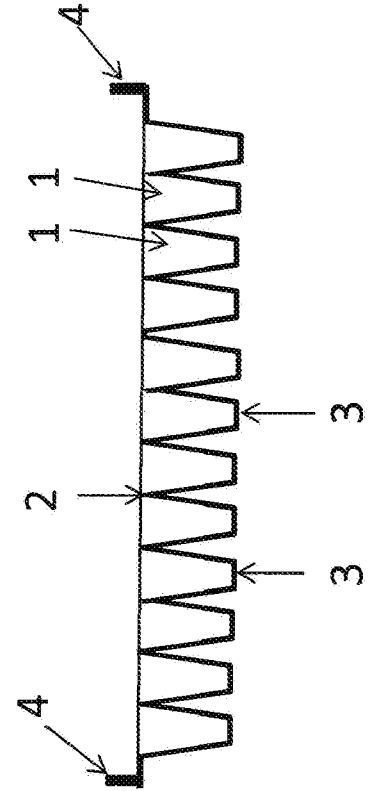

FIG. 1b

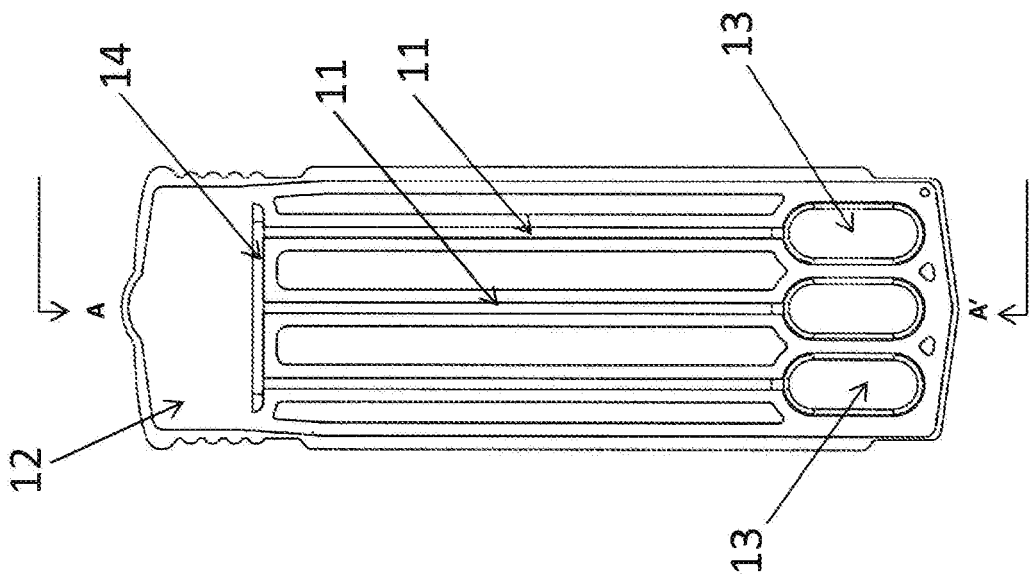
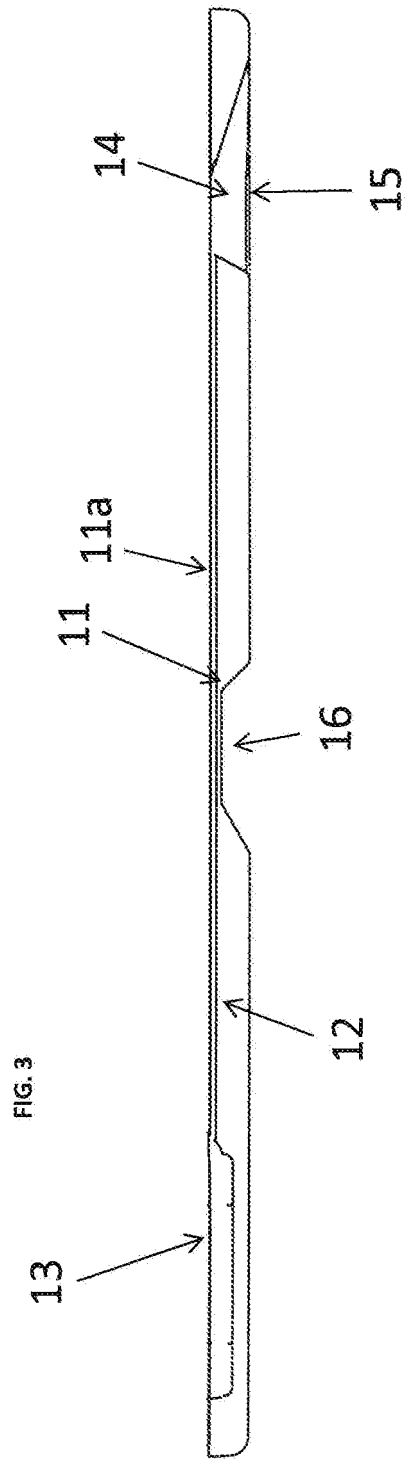
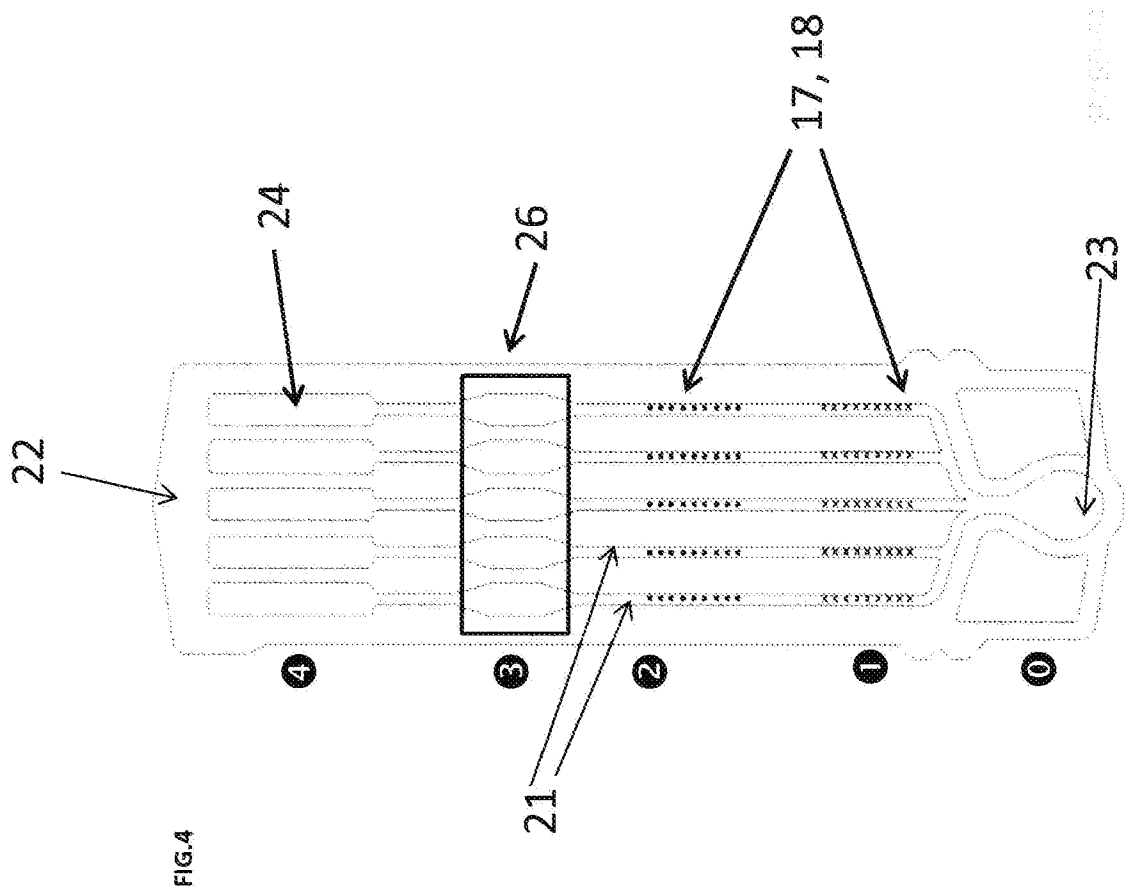

FIG. 2





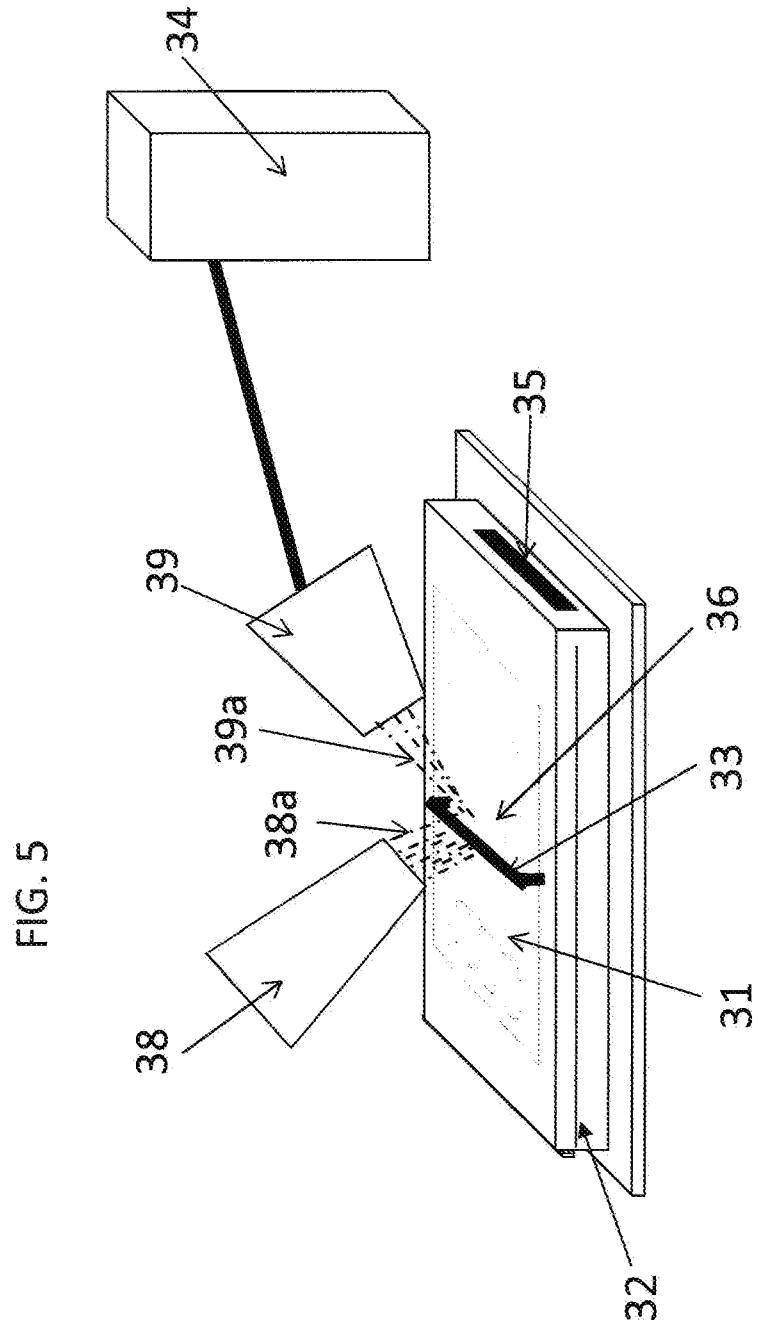
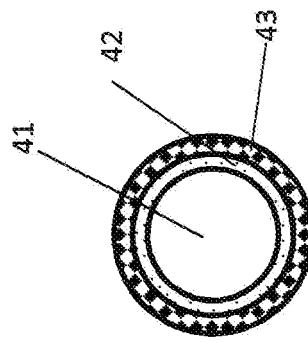
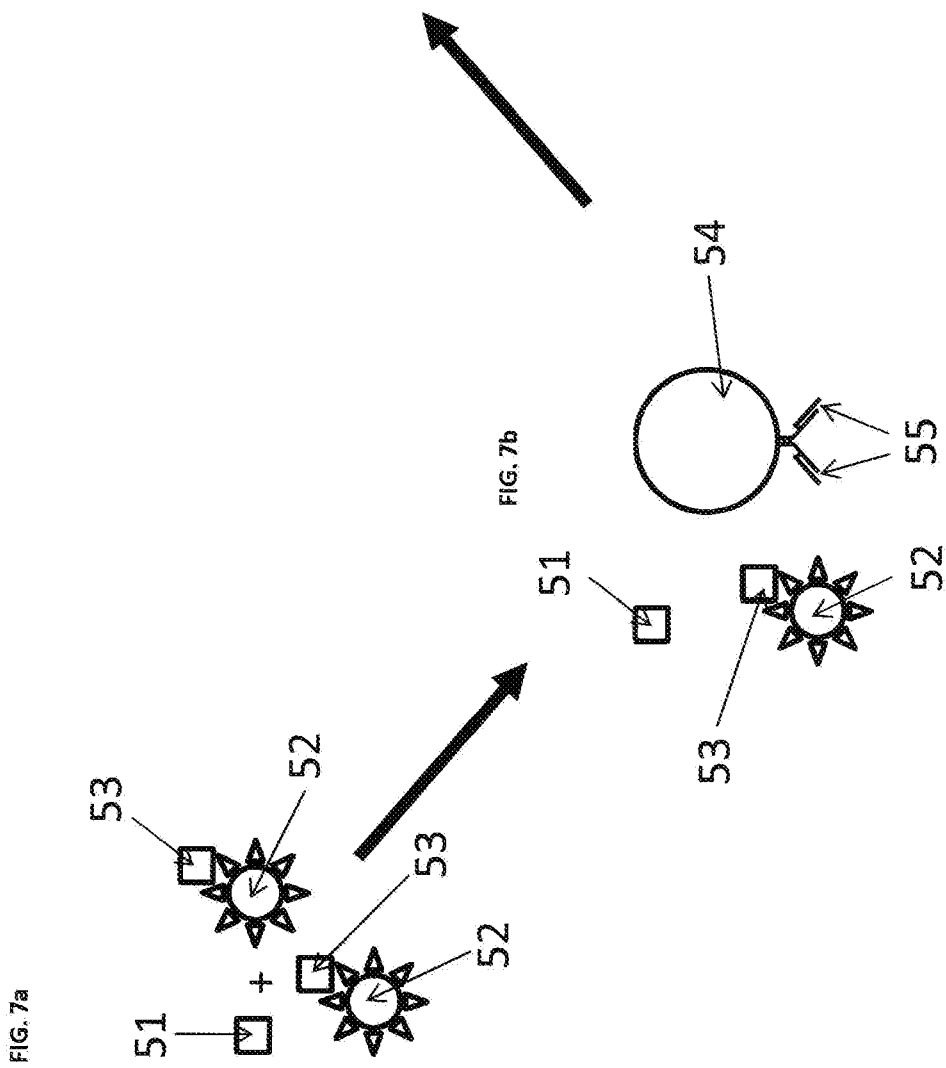
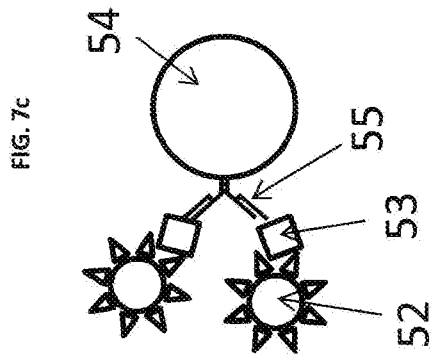
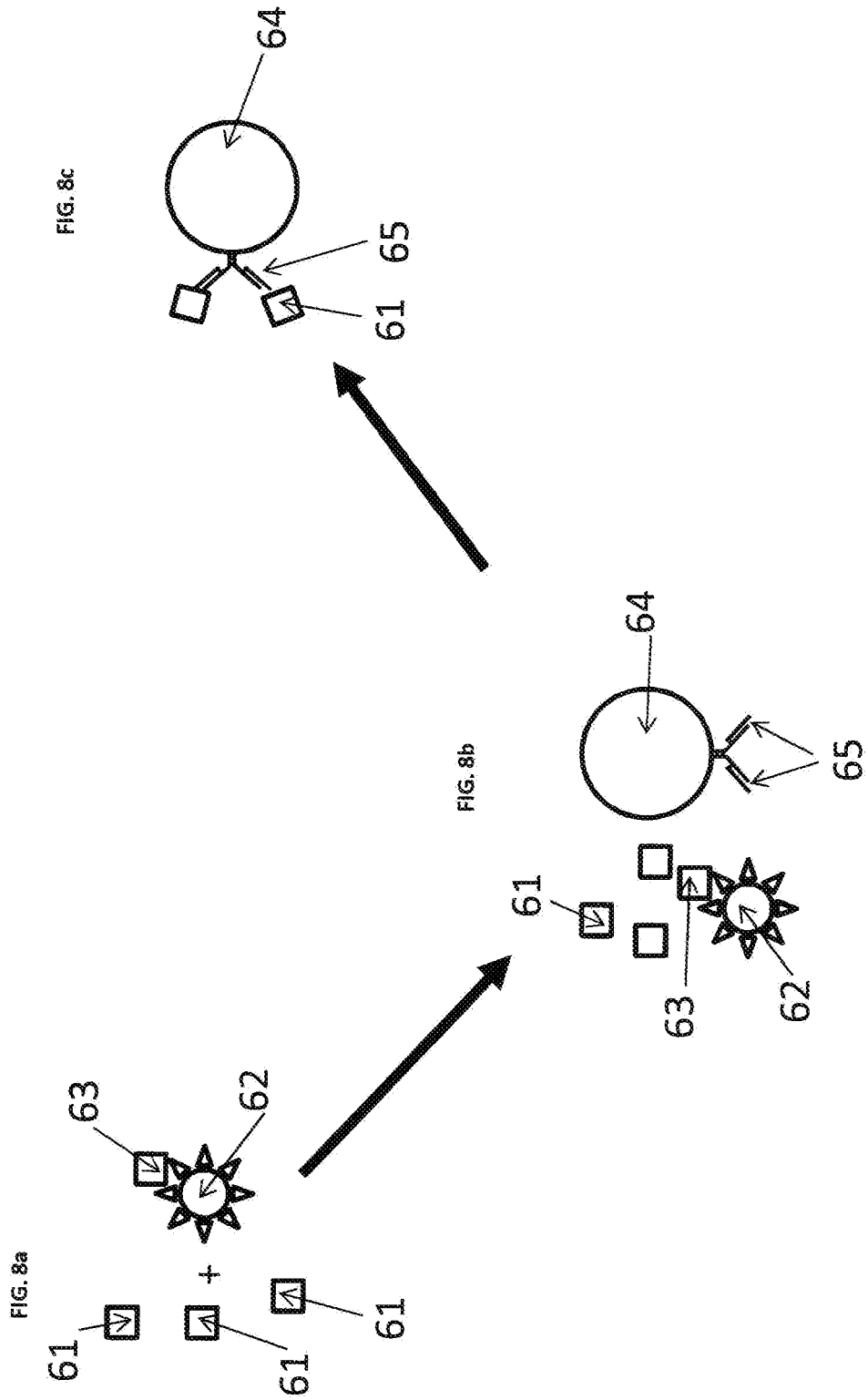

FIG. 6







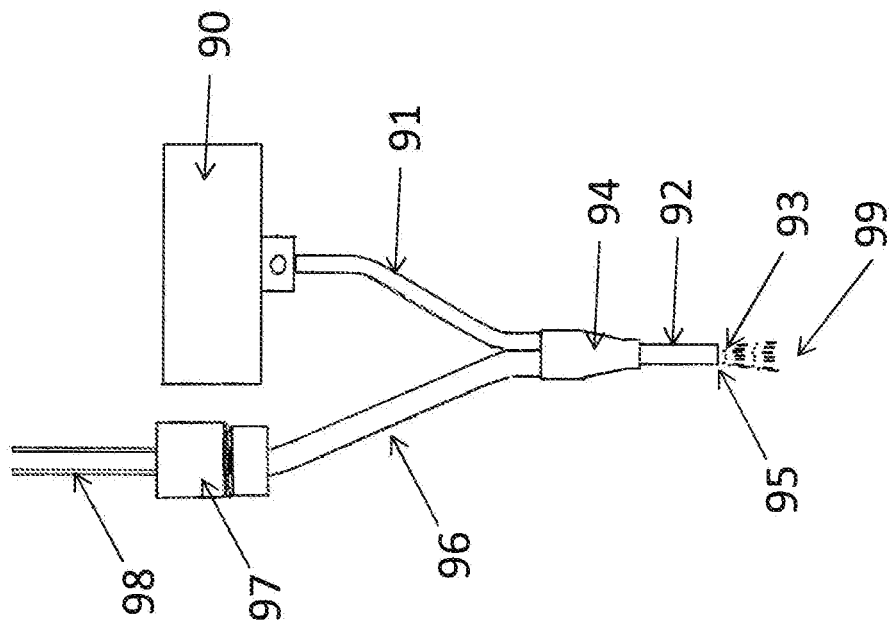

FIG. 9

REFERENCES CITED IN THE DESCRIPTION

This list of references cited by the applicant is for the reader's convenience only. It does not form part of the European patent document. Even though great care has been taken in compiling the references, errors or omissions cannot be excluded and the EPO disclaims all liability in this regard.

Patent documents cited in the description

- US 4731337 A [0004]
- WO 2010042242 A [0006]
- WO 2008109675 A [0007]
- US 20100248258 A [0008]
- US 4347312 A [0009]
- WO 2007092713 A [0010]
- WO 2012032294 A [0011]
- US 2004043512 A [0013]
- EP 2287611 A [0014]
- WO 2012016107 A [0052]
- US 7498177 B [0075]
- US 20100254858 A [0102]
- EP 1827693 A [0102]
- US 20090270269 A [0195]
- WO 2010141105 A [0195]

Non-patent literature cited in the description

- FUNCTIONALIZED EUROPIUM OXIDE NANOPARTICLES USED AS AFLUORESCENT LAEL IN AN IMMUNOASSAY FOR ATRAZINE. **FENG J et al.** Analytical chemistry. American chemical society, 01 October 2003, vol. 75, 5282-5286 [0012]
- **SAFARIK, I. ; SAFARIKOVA, M.** Magnetic techniques for the isolation and purification of proteins and peptides. *BioMagn. Res. Technol.*, 2004, 2 [0063]
- luminescent quantum dots for multiplexed biological detection and imaging. **CHAN et al.** Current Opinion in Biotechnology. Elsevier Science, 2002, vol. 13, 40-46 [0195]

专利名称(译)	用于定量或定性确定目标组分的方法和系统		
公开(公告)号	EP2864781B1	公开(公告)日	2017-12-13
申请号	EP2013807718	申请日	2013-06-21
申请(专利权)人(译)	斯堪的纳维亚MICRO BIODEVICES APS		
当前申请(专利权)人(译)	斯堪的纳维亚MICRO BIODEVICES APS		
[标]发明人	HELLER MARTIN OVERBY BENT BAU MADSEN NIELS KRISTIAN		
发明人	HELLER, MARTIN OVERBY, BENT BAU-MADSEN, NIELS KRISTIAN		
IPC分类号	G01N33/533 G01N33/50 G01N33/58 G01N21/64 B01L3/00		
CPC分类号	G01N33/54333 B01L3/502715 B01L3/50273 B01L3/502761 B01L2200/0668 B01L2300/0654 B01L2300/0663 B01L2300/0816 B01L2300/087 B01L2300/0877 B01L2300/123 B01L2300/18 B01L2400/043 B01L2400/0481 B01L2400/049 B82Y15/00 G01N21/6428 G01N21/6489 G01N33/04 G01N33/12 G01N33/5005 G01N33/53 G01N33/54326 G01N33/54386 G01N33/569 G01N33/582 G01N33/587 G01N33/588 G01N2021/6439 G01N2021/6441 G01N2021/6484 G01N2033/0095		
优先权	201270353 2012-06-22 DK		
其他公开文献	EP2864781A4 EP2864781A1		
外部链接	Espacenet		

摘要(译)

用于定量或定性测定液体样品中的目标组分的方法和系统包括：i) 在其各自的表面上提供多个磁性颗粒，所述磁性颗粒包括用于目标组分的一个或多个捕获位点；ii) 提供多个荧光团，其配置成与磁性粒子的捕获位点结合；iii) 使液体样品与包含透明窗口的微流体装置的流动通道中的荧光团和磁性颗粒接触；iv) 至少暂时使用磁铁固定邻近透明窗口的磁性颗粒，向固定的磁性颗粒发射激发的电磁束，读取由固定的磁性颗粒捕获的荧光团发出的信号，并对目标进行定量或定性测定基于读信号的分量。

