

(19) World Intellectual Property Organization  
International Bureau



(43) International Publication Date  
6 December 2001 (06.12.2001)

PCT

(10) International Publication Number  
WO 01/92567 A2

(51) International Patent Classification<sup>7</sup>: C12Q 1/68,  
A01Q 67/027

Birgit [DE/DE]; Heiterwangerstrasse 10, 81373 Munich (DE). **BECK, Joachim** [DE/DE]; Herterichstrasse 115, 81477 Munich (DE). **HENKEL, Thomas** [DE/DE]; Freienfelsstrasse 20a, 81249 Munich (DE).

(21) International Application Number: PCT/EP01/06165

(22) International Filing Date: 30 May 2001 (30.05.2001)

(74) Agents: **LEIDESCHER, Thomas** et al.; Zimmermann & Partner, Postfach 33 09 20, 80069 Munich (DE).

(25) Filing Language: English

(81) Designated States (national): AU, CA, JP, US.

(26) Publication Language: English

(84) Designated States (regional): European patent (AT, BE, CH, CY, DE, DK, ES, FI, FR, GB, GR, IE, IT, LU, MC, NL, PT, SE, TR).

(30) Priority Data:  
60/207,400 30 May 2000 (30.05.2000) US

(71) Applicant (for all designated States except US): **MEDI-GENE AG** [DE/DE]; Lochhamer Strasse 11, 82152 Planegg/Martinsried (DE).

**Published:**  
— without international search report and to be republished upon receipt of that report

(72) Inventors; and

(75) Inventors/Applicants (for US only): **BUNK, Daniela** [DE/DE]; Hofmark 8, 82393 Iffeldorf (DE). **REUNER,**

For two-letter codes and other abbreviations, refer to the "Guidance Notes on Codes and Abbreviations" appearing at the beginning of each regular issue of the PCT Gazette.

(54) Title: NOVEL TARGET GENES FOR DISEASES OF THE HEART

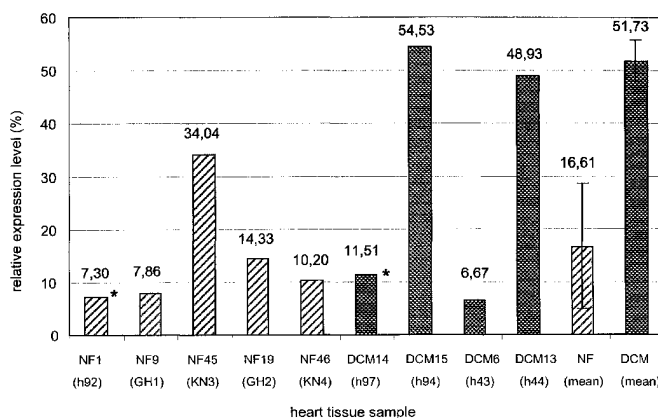

(57) Abstract: The present invention relates to a variety of genes abnormally expressed in heart tissue as well as to fragments of such genes. Assessment of the expression level of these genes may be used for testing the predisposition of mammals and preferably humans for a heart disease or for an acute state of such a disease. Preferred diseases in accordance with the invention are congestive heart failure, dilative cardiomyopathy, hypertrophic cardiomyopathy and ischemic cardiomyopathy. The present invention further relates to methods of identifying compounds capable of normalizing the expression level of the aforementioned genes and of further genes affected by the abnormal expression. The identified compounds may be used for formulating compositions, preferably pharmaceutical compositions for preventing or treating diseases. They may also be used as lead compounds for the development of medicaments having an improved efficiency, a longer half-life, a decreased toxicity etc. and to be employed in the treatment of heart diseases. Included in the invention are also somatic gene therapy methods comprising the introduction of at least one functional copy of any of the above-mentioned genes into a suitable cell. Finally, the invention relates to non-human transgenic animals comprising at least one of the aforementioned genes in their germ line. The transgenic animals of the invention may be used for the development of medicaments for the treatment of heart diseases.

WO 01/92567 A2

### Novel target genes for diseases of the heart

A variety of documents is cited throughout this specification. The disclosure content of said  
5 documents is herewith incorporated by reference.

The present invention is based on the finding that a variety of genes is abnormally  
expressed in diseased heart tissue. Assessment of the expression level of these genes may  
be used for testing the predisposition of mammals and preferably humans for a heart  
10 disease or for an acute state of such a disease. Diseases that preferably relate to the present  
invention are congestive heart failure, dilative cardiomyopathy, hypertrophic  
cardiomyopathy and ischemic cardiomyopathy. The present invention further relates to  
methods of identifying compounds capable of normalizing the expression level of the  
aforementioned genes and of further genes affected by the abnormal expression. The  
15 identified compounds may be used for formulating compositions, preferably  
pharmaceutical compositions, for preventing or treating diseases. They may also be used as  
lead compounds for the development of medicaments having an improved efficiency, a  
longer half-life, a decreased toxicity etc. and to be employed in the treatment of heart  
diseases. Included in the invention are also somatic gene therapy methods comprising the  
20 introduction of at least one functional copy of any of the above-mentioned genes into a  
suitable cell. Finally, the invention relates to non-human transgenic animals comprising at  
least one of the aforementioned genes in their germ line. The transgenic animals of the  
invention may be used for the development of medicaments for the treatment of heart  
diseases.

25

Referring to studies of the American Heart Association, about 60 million people in the  
USA suffer from Cardiovascular diseases like high blood pressure (50.0 mio), Coronary  
heart disease (12.4 mio), Myocardial infarction (7.3 mio), Angina pectoris (6.4 mio), Stroke  
(4.5 mio), Congenital cardiovascular defects (1.0 mio), and Congestive heart failure (4.7  
30 mio). Hence, it follows that 20 per cent of whole population is affected. The mortality was  
949,619 in 1998 in the USA, which means that about 40 % of all deaths were caused by

Cardiovascular diseases. Since 1900 Cardiovascular diseases are the number one cause of death (1918 was an exception) with one death every 33 seconds on average. At present there is no causal treatment for congestive heart failure available.

5 Accordingly, the technical problem underlying the present invention was to provide a new generation of tools useful in the diagnosis, prevention and treatment of heart-related diseases.

10 The solution to said technical problem is achieved by providing the methods of independent claims 1, 3, 12, 13, 15, 19, 21, 22, 23, 27, 29, 31, 32, 34, 35, 36, 40 to 44, and 46, the monoclonal antibody according to claim 14, the transgenic non-human mammal according to claim 16, and the use according to independent claim 47. Further advantageous features, aspects and details of the invention are evident from the dependent claims, the description, the examples and the drawings.

15

The invention is based upon the unexpected result that the certain genes coding for the protein sequences given in examples 2 to 11 are deregulated in the comparison of one or more failing heart samples to one or more non-failing heart samples and lead to an upregulation (examples 2, 5, 8, 9, 10) or downregulation (examples 3, 4, 6, 7) of the described polypeptides measured by their respective mRNAs or cDNAs. The significant changes in gene expression levels suggest a causative role in congestive heart failure.

20

However, such a causative role for one specific indication of the heart leads to the assumption that a deregulation of such gene(s) might play an important role in other diseases of the heart as well. Such involvement can easily be tested by methods well known in the art and described e. g. in example 1 of the present application by a comparison of the gene expression levels of such gene between a sample of a healthy mammal and of a mammal having the disease in question. Therefore the subject of this invention does not only relate to dilated cardiomyopathy but also to other diseases of the heart.

30

It is well accepted in the art that upregulation of gene expression of a downregulated target gene by means of a gene therapeutic intervention, compensatory molecules or specific activators, for example of transcription or translation, are potentially very promising therapeutic tools to treat a heart disease that is caused or promoted by the downregulation  
5 of such gene.

On the other hand, downregulation of gene expression and/or protein function of an upregulated target gene by means of specific inhibitors, antisense constructs, ribozymes, antibodies or any other compound (as hereinafter defined) are well accepted tools to treat  
10 a heart disease that is caused or promoted by the upregulation of such gene.

As one gene might be upregulated for one indication of the heart whereas the same gene might be downregulated for another indication of the heart, both upregulation of gene expression as well as downregulation of gene expression and/or protein function might be  
15 useful for the same target gene in different indications.

The same holds true for methods for identifying a subject at risk for a disease of the heart, a method for identifying a compound, a method for identifying one or a plurality of genes as well as methods to make transgenic non-human mammals. In all these various  
20 embodiments of the invention aberrant gene expression in either direction can be used for the given methods.

Thus, the present invention relates to a method for identifying a subject at risk for a disease of the heart, comprising the step of quantitating in the heart tissue of the subject the amount  
25 of at least one RNA encoding an amino acid sequence selected from the group consisting of:

(a) the amino acid sequence of SEQ ID NO: 1 [NP\_003961], the amino acid sequence of SEQ ID NO: 2 [41441pep], the amino acid sequence of SEQ ID NO: 3 [56461pep], the amino acid sequence of SEQ ID NO: 4 [AAA52025], the amino acid sequence of SEQ ID  
30 NO: 5 [61166pep], the amino acid sequence of SEQ ID NO: 6 [AAD45360], the amino acid sequence of SEQ ID NO: 7 [AAF63623], the amino acid sequence of SEQ ID NO: 8

[66214pep] or the amino acid sequence AAF19343, or the amino acid sequence of SEQ ID NO: 9 [CAA58676];

(b) an amino acid sequence that is at least 60%, preferably at least 80%, especially at least 90%, advantageously at least 99% identical to the amino acid sequence of (a);

5 (c) the amino acid sequence of (a) with at least one conservative amino acid substitution;

(d) an amino acid sequence that is an isoform of the amino acid sequence of any of (a) to (c);

(e) the RNA transcribed from the DNA sequence of SEQ ID NO: 10 [NM\_003970], the DNA sequence of SEQ ID NO: 11 [AW755252], the DNA sequence of SEQ ID NO: 12 [EST clone 52706], the DNA sequence of SEQ ID NO: 13 [EST clone 56461], the DNA sequence of SEQ ID NO: 14 [M14780], the DNA sequence of SEQ ID NO: 15 [61166contig], the DNA sequence of SEQ ID NO: 16 [AF161698], the DNA sequence of SEQ ID NO: 17 [65330contig], the DNA sequence of SEQ ID NO: 18 [66214cds] or the DNA sequence AF129505, or the DNA sequence of SEQ ID NO: 19 [X83703] or a degenerate variant thereof; and

(f) an amino acid that is encoded by a DNA molecule the complementary strand of which hybridizes in 4xSSC, 0.1% SDS at 65°C to the DNA molecule encoding the amino acid sequence of (a), (c) or (d).

The term "disease of the heart" means, in accordance with the present invention, any disease that affects the normal function of the heart. This definition includes hereditary as well as acquired diseases such as diseases induced by a pathogen or diseases due to lack of exercise.

Several diseases of the heart are, for example, rheumatic fever/ rheumatic heart disease, hypertensive heart disease, hypertensive heart and renal disease, ischemic heart disease (coronary heart disease), diseases of pulmonary circulation (which include acute and chronic pulmonary heart disease), arrhythmias, congenital heart disease, angina and congestive heart failure.

The term "quantitating the amount of at least one RNA" is intended to mean the determination of the amount of mRNA in heart tissue as compared to a standard value such as an internal standard. The (internal) standard would advantageously be the amount of a corresponding RNA produced by a heart tissue not affected by a disease. Said (internal)

standard would also include a mean value obtained from a variety of heart tissues not affected by a disease. A possible way to get samples of heart tissue would be to take a biopsy (catheter) from the ventricular wall. Optionally, a standard would take into account the genetic background of the subject under investigation. Thus, quantitation of said subject's RNA is effected in comparison to the amount of RNA of one or a variety of samples of the same or a similar genetic background. A variable number of "non-failing" humans (humans that do not show an indication for any heart disease) are compared with a variable number of patients that suffer a distinct heart disease like dilated cardiomyopathy. The determination can be effected by any known technology of analysing the amount of RNA produced in a sample such as a tissue sample. Techniques based on hybridisation like Northern-Blot, dot-blot, subtractive hybridisation, DNA-Chip analysis or techniques based on reverse transcription coupled to the polymerase chain reaction (RT-PCR) like differential display, suppression subtractive hybridisation (SSH), fluorescence differential display (FDD), serial analysis of gene expression (SAGE) or representational difference analysis (see e. g. Kozian, D.H., Kirschbaum, B.J.; Comparative gene-expression analysis. (1999) 17:73-77). Generally, it is preferred that the assay is performed as a high throughput assay. This holds also true for the further methods described herein and in accordance with this invention. Samples of RNA may be prepared as described in the appended examples.

The term "isoform" means a derivative of a gene resulting from alternative splicing, alternative polyadenylation, alternative promoter usage or RNA editing. Isoforms can be detected by

- (a) *in silico* analysis (e.g. by clustering analysis of any types of expressed sequences or the corresponding proteins, by alignment of expressed sequences with chromosomal DNA, by interspecies comparisons or by analysis of the coding as well as non-coding sequences like promoters or regulatory RNA processing sites for SNPs or known mutations causing a disease).
- (b) any type of hybridisation techniques (1,2) (e.g. Northern blots, nuclease protection assays, microarrays) starting from RNA.
- (c) PCR-applications as well as hybridisation techniques starting from single strand or double strand cDNA obtained by reverse transcription (3), as described for example in

Higgins, S.J., Hames, D. RNA Processing: A practical approach Oxford University Press (1994), Vol. 1 and 2; Sambrook, Fritsch, Maniatis, Molecular Cloning, a laboratory manual. (1989) Cold Spring Harbor Laboratory Press; Stoss, O. Stoilov, P., Hartmann, A.M., Nayler, O., Stamm, S., The *in vivo* minigene approach to analyse  
5 tissue-specific splicing. Brain Res. Brain Res. Protoc. (1999), 3:383-394.

Primers/probes for RT-PCR or hybridisation techniques are designed in a fashion that at least one of the primers/probes recognizes specifically one isoform. If differences in the molecular weight of isoforms are big enough to separate them with electrophoretical or chromatographical methods, it is also possible to detect multiple isoforms at once by  
10 employing primers/probes that flank the spliced regions. The isoforms are then sequenced and analysed as described in (a).

The term "DNA molecule the complementary strand of which hybridizes in 4xSSC, 0.1% SDS at 65°C to the DNA molecule encoding the amino acid sequence of (a), (c) or (d)"  
15 means that the two DNA molecules hybridize under these experimental conditions to each other. This term does not exclude that the two DNA sequences hybridize at higher stringency conditions such as 2xSSC, 0.1% SDS at 65°C nor does it exclude that lower stringency conditions such as 6xSSC, 0.1% SDS at 60°C allow a hybridization of the two DNA sequences.

20 Appropriate hybridization conditions for each sequence may be established on well-known parameters such as temperature, composition of the nucleic acid molecules, salt conditions etc.; see, for example, Sambrook et al., "Molecular Cloning, A Laboratory Manual"; CSH Press, Cold Spring Harbor, 1989 or Higgins and Harnes (eds.), "Nucleic acid hybridization, a practical approach", IRL Press, Oxford 1985, see in particular the chapter "Hybridization  
25 Strategy" by Britten & Davidson, 3 to 15.

In accordance with the present invention it has surprisingly been found that a variety of genes is aberrantly expressed in diseases associated with the heart and in particular in  
30 patients suffering from congestive heart failure. By performing the method of the invention which may be *in vivo*, *in vitro* or *in silico*, the diagnosis of a disease of the heart established

by a different methodology may be corroborated. Alternatively, it may be assessed whether a subject that is preferably throughout this specification a human displaying no sign of being affected by a disease of the heart is at risk of developing such a disease. This is possible in cases where the aberrant expression of the gene defined herein above is causative of the disease or is a member of a protein cascade wherein another gene/protein than the one identified herein above is causative for said disease. In this regard, the term "causative" is not limited to mean that the aberrant expression of one gene as identified above or which is a member of said protein cascade is the sole cause for the onset of the disease. Whereas this option is also within the scope of the invention, expression the invention also encompasses embodiments wherein said aberrant is one of a variety of causative events that lead to the onset of the disease.

There is causal correlation between altered cellular function of cardiomyocytes and its protein composition. The latter is regulated by three main mechanisms:

- a. Gene expression
- b. Alternative splicing
- c. Posttranslational modification

In a variation of the method of the invention quantitation of the above recited RNA is used to monitor the progress of a disease of the heart (said variation also applies to the method described herein below). This variation may be employed for assessing the efficacy of a medicament or to determine a time point when administration of a drug is no longer necessary or when the dose of a drug may be reduced and/or when the time interval between administrations of the medicament may be increased. This variation of the method of the invention may successfully be employed in cases where an aberrant expression of any of the aforementioned genes/genes as members of protein cascades is causative of the disease. It is also useful in cases where the aberrant expression of the gene/genes is the direct or indirect result of said disease.

When assessing the risk or the status of the disease, one or more of the RNA levels may be determined. Generally, the assessment of more than 1, such as 2, 3, 4, 5, 6, 7, 8, 9 or 10

different RNAs is expected to enhance the fidelity of the prognosis/diagnosis. However, the gain in fidelity would, as a rule, have to be weighted against the costs generated by such additional tests. Accordingly, it is preferred that one or two different RNA levels are determined for a first assessment. If deemed necessary or appropriate, further RNA levels  
5 may be determined.

In a preferred embodiment of the method of the invention the amount of the said RNA is quantitated using a nucleic acid probe which is a nucleic acid comprising a sequence selected from the group consisting of:

- 10 (a) the DNA sequence of SEQ ID NO: 10 [NM\_003970], the DNA sequence of SEQ ID NO: 11 [AW755252], the DNA sequence of SEQ ID NO: 12 [EST clone 52706], the DNA sequence of SEQ ID NO: 13 [EST clone 56461], the DNA sequence of SEQ ID NO: 14 [M14780], the DNA sequence of SEQ ID NO: 15 [61166contig], the DNA sequence of SEQ ID NO: 16 [AF161698], the DNA sequence of SEQ ID NO: 17 [65330contig], the  
15 DNA sequence of SEQ ID NO: 18 [66214cds] or the DNA sequence AF129505, or the DNA sequence of SEQ ID NO: 19 [X83703] or a degenerate variant thereof (b) a DNA sequence at least 60%, preferably 80%, especially 90%, advantageously 99% identical to the DNA sequence of (a); (c) a nucleic acid sequence that encodes the amino acid sequence  
20 SEQ ID NO: 1 [NP\_003961], the amino acid sequence of SEQ ID NO: 2 [41441pep], the amino acid sequence of SEQ ID NO: 3 [56461pep], the amino acid sequence of SEQ ID NO: 4 [AAA52025], the amino acid sequence of SEQ ID NO: 5 [61166pep], the amino acid sequence of SEQ ID NO: 6 [AAD45360], the amino acid sequence of SEQ ID NO: 7 [AAF63623], the amino acid sequence of SEQ ID NO: 8 [66214pep] or the amino acid  
25 sequence AAF19343, or the amino acid sequence of SEQ ID NO: 9 [CAA58676]; with at least one conservative amino acid substitution; (d) a nucleic acid sequence that encodes an amino acid sequence that is at least 60%, preferably 80%, especially 90%, advantageously 99% identical to the amino acid sequence of (b); (e) a nucleic acid sequence that encodes the amino acid sequence of (a) or (b) with at least one conservative amino acid substitution;  
30 (f) a nucleic acid sequence that hybridizes in 4xSSC, 0.1% SDS at 65°C to the complementary strand of the DNA molecule encoding the amino acid sequence of (a) or (c); and (g) a fragment of at least 15 nucleotides in length of (a) to (f).

Advantageously, the nucleic acid sequence which is preferably a DNA sequence is detectably labeled. Appropriate labels include radioactive labels, wherein the radioactivity conferring molecules may be, e.g.,  $^{32}\text{P}$ ,  $^{35}\text{S}$  or  $^3\text{H}$ . Appropriate labels further include  
5 fluorescent, phosphorescent or bioluminescent labels or nucleic acid sequences coupled to biotin or streptavidin in order to detect them via anti-biotin or anti-streptavidin antibodies. Whereas any of the above mentioned probes specifically hybridizing to the aforementioned RNAs may be employed, it is preferred that fragments of the full length coding sequence such as oligomers of a length between 15 and 25 nucleotides are used. Examples of such  
10 oligomers are oligomers of 18, 21 or 24 nucleotides. Alternatively, the double strand formed after hybridization can be detected by anti-double strand DNA specific antibodies or aptamers etc.

In this regard, it is understood that the probe of SEQ ID NO: 10 and the mentioned variants thereof are used for quantitating the RNA of SEQ ID NO: 1, but not to any of the other  
15 mentioned RNAs. In the following, appropriate pairs of RNAs and corresponding probes for assessing risks etc. of diseases of the heart are mentioned with the understanding that (i) appropriate variants of the probes as mentioned above may be used and (ii) said probes are specific for the corresponding RNA only but not for any of the other mentioned RNAs. These pairs are: SEQ ID NOs: 2/SEQ ID NO: 11; SEQ ID NO: 3/SEQ ID NO: 13; SEQ ID  
20 NO: 4/SEQ ID NO: 14; SEQ ID NO: 5/SEQ ID NO: 15; SEQ ID NO: 6/SEQ ID NO: 16; SEQ ID NO: 7/SEQ ID NO: 17; SEQ ID NOs: 8/SEQ ID NO: 18; SEQ ID NO: 9/SEQ ID NO: 19.

After hybridization, appropriate washing steps are performed in order to remove unspecific  
25 signals. Appropriate washing conditions include 2 wash steps at 65°C with 2xSSC, 0,1% SDS for 30 min (50 ml) and finally two wash steps with 50 ml of a solution containing 0.1xSSC, 0.1% SDS for 30 min.; see also Sambrook et al., *loc. cit.*, Higgins and Hames, *loc. cit.* After washing, the label is detected, depending on its nature. For example, a radioactive label may be detected by exposure to an X-ray film or by a phosphorimager.  
30 Alternatively, biotinylated probes can be detected by fluorescence, e.g. by using SAPE (streptavidin-phycoerythrin) with subsequent detection of the signal by a laser scanner.

In addition, the invention relates to a method for identifying a subject at risk for a disease of the heart, comprising the step of quantitating in the heart tissue of the subject the amount of a polypeptide selected from the group consisting of: (a) the polypeptide having amino acid sequence SEQ ID NO: 1 [NP\_003961], the amino acid sequence of SEQ ID NO: 2 [41441pep], the amino acid sequence of SEQ ID NO: 3 [56461pep], the amino acid sequence of SEQ ID NO: 4 [AAA52025], the amino acid sequence of SEQ ID NO: 5 [61166pep], the amino acid sequence of SEQ ID NO: 6 [AAD45360], the amino acid sequence of SEQ ID NO: 7 [AAF63623], the amino acid sequence of SEQ ID NO: 8 [66214pep] or the amino acid sequence AAF19343, or the amino acid sequence of SEQ ID NO: 9 [CAA58676]; (b) a polypeptide having an amino acid sequence that is at least 60%, preferably at least 80%, especially at least 90%, advantageously at least 99% identical to the amino acid sequence of (a); and (c) a polypeptide having the amino acid sequence of (a) with at least one conservative amino acid substitution. Further included are polypeptides encoded by any of the above recited nucleic acid sequences. This holds also true for any of the other embodiments in which the aforementioned polypeptides are employed.

This embodiment of the invention makes use of the option that detection may not only be at the level of the mRNA but also at the level of the polypeptide translated from the mRNA. Whereas it is not excluded that the level of mRNA strictly correlates with the level of polypeptide translated from the mRNA, this may not always be the case. Accordingly, it may be assessed whether the mRNA or the protein level, if different, is more appropriate to establish if the heart of a subject is prone to develop a disease of the heart. Factors that contribute to differences in the expression levels of mRNA and protein are well-known in the art and include differential mRNA-export to the protein-synthesis machinery as well as differences in the translation efficacy of different mRNA species. Other considerations influencing the choice of the detection level (in RNA or protein) include the availability of an appropriate screening tool, instrumentation of the lab, experience of the lab personnel and others.

30

In a preferred embodiment of the method of the invention, the amount of the said

polypeptide is quantitated using an antibody that specifically binds a polypeptide selected from the group consisting of: (a) the polypeptide having amino acid sequence of SEQ ID NO: 1 [NP\_003961], the amino acid sequence of SEQ ID NO: 2 [41441pep], the amino acid sequence of SEQ ID NO: 3 [56461pep], the amino acid sequence of SEQ ID NO: 4 [AAA52025], the amino acid sequence of SEQ ID NO: 5 [61166pep], the amino acid sequence of SEQ ID NO: 6 [AAD45360], the amino acid sequence of SEQ ID NO: 7 [AAF63623], the amino acid sequence of SEQ ID NO: 8 [66214pep] or the amino acid sequence AAF19343, or the amino acid sequence of SEQ ID NO: 9 [CAA58676]; (b) a polypeptide having an amino acid sequence that is at least 60%, preferably 80%, especially 90%, advantageously 99% identical to the amino acid sequence of (a); and (c) a polypeptide having the amino acid sequence of (a) with at least one conservative amino acid substitution, or an antigen-binding portion of said antibody.

The antibody used in accordance with the invention may be a monoclonal or a polyclonal antibody (see Harlow and Lane, „Antibodies, A Laboratory Manual“, CSH Press, Cold Spring Harbor, USA, 1988) or a derivative of said antibody which retains or essentially retains its binding specificity. Whereas particularly preferred embodiments of said derivatives are specified further herein below, other preferred derivatives of such antibodies are chimeric antibodies comprising, for example, a mouse or rat variable region and a human constant region. The term "specifically binds" in connection with the antibody used in accordance with the present invention means that the antibody etc. does not or essentially does not cross-react with (poly)peptides of similar structures. Cross-reactivity of a panel of antibodies etc. under investigation may be tested, for example, by assessing binding of said panel of antibodies etc. under conventional conditions (see, e.g., Harlow and Lane, *loc. cit.*) to the polypeptide of interest as well as to a number of more or less (structurally and/or functionally) closely related polypeptides. Only those antibodies that bind to the polypeptide of interest but do not or do not essentially bind to any of the other (poly)peptides which are preferably expressed by the same tissue as the polypeptide of interest, i.e. heart, are considered specific for the polypeptide of interest and selected for further studies in accordance with the method of the invention.

In a particularly preferred embodiment of the method of the invention, said antibody or antibody binding portion is or is derived from a human antibody or a humanized antibody.

5 The term "humanized antibody" means, in accordance with the present invention, an antibody of non-human origin, where at least one complementarity determining region (CDR) in the variable regions such as the CDR3 and preferably all 6 CDRs have been replaced by CDRs of an antibody of human origin having a desired specificity. Optionally, the non-human constant region(s) of the antibody has/have been replaced by (a) constant region(s) of a human antibody. Methods for the production of humanized antibodies are  
10 described in, e.g., EP-A1 0 239 400 and WO90/07861.

The specifically binding antibody etc. may be detected by using, for example, a labeled secondary antibody specifically recognizing the constant region of the first antibody. However, in a further particularly preferred embodiment of the method of the invention, the  
15 antibody, the binding portion or derivative thereof itself is detectably labeled.

Detectable labels include a variety of established labels such as radioactive ( $^{125}\text{I}$ , for example) or fluorescent labels (see, e.g. Harlow and Lane, *loc. cit.*). Binding may be detected after removing unspecific labels by appropriate washing conditions (see, e.g. Harlow and Lane, *loc. cit.*).  
20

In an additionally preferred embodiment of the method of the invention, said derivative of said antibody is an scFv fragment.

The term "scFv fragment" (single-chain Fv fragment) is well understood in the art and preferred due to its small size and the possibility to recombinantly produce such fragments.  
25

In a preferred embodiment of the method of the invention, said RNA is obtained from heart tissue.

A suitable way would be to take a biopsy (catheter) from the ventricular wall. The decision  
30 to do this is clearly affected by the severity of the disease and the general constitution of the patient. The cardiologist and the patient have to drive the final decision. In an additionally

preferred embodiment of the method of the invention, said polypeptide is quantitated in heart tissue.

5 In another preferred embodiment, the method of the invention further comprises the step of normalizing the amount of RNA against a corresponding RNA from a healthy subject or cells derived from a healthy subject.

The term "healthy subject" means a subject without any indication for heart disease.

The term "normalizing the amount of RNA against a corresponding RNA from a healthy subject or cells derived from a healthy subject" means, in accordance with the present  
10 invention, that levels of mRNA from a comparative number of cells from the heart of said subject under investigation and from the heart of an individual not affected by a disease of the heart are compared. Alternatively, cells from the heart of the subject under investigation may be compared in terms of the indicated mRNA levels with cells derived from the heart of a healthy individual which are kept in cell culture and optionally form a  
15 cell line. Optionally, different sources of cells such as from different individuals and/or different cell lines may be used for the generation of the standard against which the mRNA level of the subject under investigation is compared.

Using the Affymetrix Chip technology, there is also the possibility to use external standards (that are given separately to the hybridisation cocktail) in order to normalize the values of  
20 different oligonucleotide-chips.

In yet another preferred embodiment, the method of the invention further comprises the step of normalizing the amount of polypeptide against a corresponding polypeptide from a healthy subject or cells derived from a healthy subject.  
25

The same considerations as developed for the previous embodiment on the mRNA level apply here to the normalization of protein levels.

30 Additionally, the invention relates to a method for identifying a compound that increases or decreases the level in heart tissue of a polypeptide selected from the group consisting of: (a) the polypeptide having amino acid sequence of SEQ ID NO: 1 [NP\_003961], the amino

acid sequence of SEQ ID NO: 2 [41441pep], the amino acid sequence of SEQ ID NO: 3 [56461pep], the amino acid sequence of SEQ ID NO: 4 [AAA52025], the amino acid sequence of SEQ ID NO: 5 [61166pep], the amino acid sequence of SEQ ID NO: 6 [AAD45360], the amino acid sequence of SEQ ID NO: 7 [AAF63623], the amino acid sequence of SEQ ID NO: 8 [66214pep] or the amino acid sequence AAF19343, or the amino acid sequence of SEQ ID NO: 9 [CAA58676]; (b) a polypeptide having an amino acid sequence that is at least 60%, preferably at least 80%, especially at least 90%, advantageously at least 99% identical to the amino acid sequence of (a); and (c) a polypeptide having the amino acid sequence of (a) with at least one conservative amino acid substitution, comprising the steps of: (1) contacting a DNA encoding said polypeptide under conditions that would permit the translation of said polypeptide with a test compound; and (2) detecting an increased or decreased level of the polypeptide relative to the level of translation obtained in the absence of the test compound.

The term "compound" shall mean any biologically active substance that has an effect on heart tissue or a single heart cell, whereas such compound has a positive or negative influence upon such heart tissue or heart cell. Preferred compounds are nucleic acids, preferably coding for a peptide, polypeptide, antisense RNA or a ribozyme or nucleic acids that act independent from their transcription respective their translation as for example as an antisense RNA or ribozyme; natural or synthetic peptides preferably with a relative molecular mass of about 1.000, especially of about 500 peptide analogs polypeptides or compositions of polypeptides, proteins, protein complexes, fusion proteins, preferably antibodies, especially murine, human or humanized antibodies, single chain antibodies, F<sub>ab</sub> fragments or any other antigen binding portion or derivative of an antibody, including modifications of such molecules as for example glycosylation, acetylation, phosphorylation, farnesylation, hydroxylation, methylation or estrification hormones, organic or anorganic molecules or compositions, preferably small molecules with a relative molecular mass of about 1.000, especially of about 500.

The term "under conditions that would permit the translation of said polypeptide" denotes any conditions that allow the in vitro or in vivo translation of the polypeptide of interest. As regards in vitro conditions, translation may be effected in a cell-free system, as described, for example in Stoss, Schwaiger, Cooper and Stamm (1999). J. Biol. Chem. 274: 10951-

10962), using the TNT-coupled reticulocyte lysate system (Promega). With respect to in vivo conditions, physiological conditions such as conditions naturally occurring inside a cell are preferred.

5 Based on the finding that expression of genes encoding the above recited polypeptides is aberrant, the method of the invention allows the convenient identification or isolation of compounds that counteract such aberrant expression such that normal expression levels are restored or essentially restored.

10 The DNA encoding the polypeptide of interest would normally be contained in an expression vector. The expression vectors may particularly be plasmids, cosmids, viruses or bacteriophages used conventionally in genetic engineering that comprise the  
aforementioned polynucleotide. Preferably, said vector is a gene transfer or targeting  
vector. Expression vectors derived from viruses such as retroviruses, vaccinia virus, adeno-  
15 associated virus, herpes viruses, or bovine papilloma virus, may be used for delivery of the  
polynucleotides into targeted cell population. Methods which are well known to those  
skilled in the art can be used to construct recombinant viral vectors; see, for example, the  
techniques described in Sambrook et al., *Molecular Cloning A Laboratory Manual*, Cold  
Spring Harbor Laboratory (1989) N.Y. and Ausubel et al., *Current Protocols in Molecular*  
20 *Biology*, Green Publishing Associates and Wiley Interscience, N.Y. (1989). Alternatively,  
the polynucleotides and vectors can be reconstituted into liposomes for delivery to target  
cells. The vectors containing the polynucleotides can be transferred into the host cell by  
well-known methods, which vary depending on the type of cellular host. For example,  
calcium phosphate or DEAE-Dextran mediated transfection or electroporation may be used  
25 for eukaryotic cellular hosts; see Sambrook, supra.

Such vectors may comprise further genes such as marker genes which allow for the  
selection of said vector in a suitable host cell and under suitable conditions. The  
polynucleotide is operatively linked to expression control sequences allowing expression in  
eukaryotic cells. Expression of said polynucleotide comprises transcription of the  
30 polynucleotide into a translatable mRNA. Regulatory elements ensuring expression in  
eukaryotic cells, preferably mammalian cells, are well known to those skilled in the art.

They usually comprise regulatory sequences ensuring initiation of transcription and, optionally, a poly-A signal ensuring termination of transcription and stabilization of the transcript, and/or an intron further enhancing expression of said polynucleotide. Additional regulatory elements may include transcriptional as well as translational enhancers, and/or naturally-associated or heterologous promoter regions. Possible regulatory elements permitting expression in eukaryotic host cells are the AOX1 or GAL1 promoter in yeast or the CMV-, SV40-, RSV-promoter (Rous sarcoma virus), CMV-enhancer, SV40-enhancer or a globin intron in mammalian and other animal cells. Beside elements which are responsible for the initiation of transcription such regulatory elements may also comprise transcription termination signals, such as the SV40-poly-A site or the tk-poly-A site, downstream of the polynucleotide. Furthermore, depending on the expression system used leader sequences capable of directing the polypeptide to a cellular compartment or secreting it into the medium may be added to the coding sequence of the aforementioned polynucleotide and are well known in the art. The leader sequence(s) is (are) assembled in appropriate phase with translation, initiation and termination sequences, and preferably, a leader sequence capable of directing secretion of translated protein, or a portion thereof, into the periplasmic space or extracellular medium. Optionally, the heterologous sequence can encode a fusion protein including an C- or N-terminal identification peptide imparting desired characteristics, e.g., stabilization or simplified purification of expressed recombinant product. In this context, suitable expression vectors are known in the art such as Okayama-Berg cDNA expression vector pcDV1 (Pharmacia), pCDM8, pRc/CMV, pcDNA1, pcDNA3, the Echo<sup>TM</sup> Cloning System (Invitrogen), pSPORT1 (GIBCO BRL) or pRevTet-On/pRevTet-Off or pCI (Promega).

Preferably, the expression control sequences will be eukaryotic promoter systems in vectors capable of transforming or transfecting eukaryotic host cells. As mentioned above, the vector used in the method of the present invention may also be a gene transfer or targeting vector. Gene therapy, which is based on introducing therapeutic genes into cells by ex-vivo or in-vivo techniques, is one of the most important applications of gene transfer. Suitable vectors and methods for in-vitro or in-vivo gene therapy are described in the literature and

are known to the person skilled in the art; see, e.g., Giordano, *Nature Medicine* 2 (1996), 534-539; Schaper, *Circ. Res.* 79 (1996), 911-919; Anderson, *Science* 256 (1992), 808-813; Isner, *Lancet* 348 (1996), 370-374; Muhlhauser, *Circ. Res.* 77 (1995), 1077-1086; Wang, *Nature Medicine* 2 (1996), 714-716; WO94/29469; WO 97/00957 or Schaper, *Current*  
5 *Opinion in Biotechnology* 7 (1996), 635-640, and references cited therein. The polynucleotides and vectors may be designed for direct introduction or for introduction via liposomes, or viral vectors (e.g. adenoviral, retroviral) into the cell. Preferably, said cell is a germ line cell, embryonic cell, or egg cell or derived therefrom, most preferably said cell is a stem cell.

10

The vector comprising the DNA would be used to transform a suitable eukaryotic host cell. Upon expression of the DNA, which may be constitutive or induced, the test compound would be contacted with the DNA. This can be done by introducing the test compound into the cell. For example, if the test compound is a (poly)peptide, then introduction may be  
15 effected by transfection of the corresponding DNA, optionally comprised in a suitable expression vector. If the compound is a small molecule, preferably with a relative molecular weight of up to 1,000, especially up to 500, the introduction into the cell may be effected by direct administration, plus DMSO for hydrophobic compounds, probably liposomal transfer.

20

In the case that the method of the invention is carried out *in vitro*, for example, in a cell-free system, then introduction into a cell would not be necessary. Rather, the test compound would be admixed to the *in vitro* expression system and the effect of said admixture observed.

25

The effect of the contact of the DNA of interest with the test compound on the protein level may be assessed by any technology that measures changes in the quantitative protein level. Such technologies include Western blots, ELISAs, RIAs and other techniques referred to herein above.

30

The change in protein level, if any, as a result of the contact of said DNA and said test

compound is compared against a standard. This standard is measured applying the same test system but omits the step of contacting the compound with the DNA. The standard may consist of the expression level of the polypeptide after no compound has been added. Alternatively, the DNA may be contacted with a compound that has previously been demonstrated to have an influence on the expression level.

Compounds tested positive for being capable of enhancing or reducing the amount of polypeptide produced are prime candidates for the direct use as a medicament or as lead compounds for the development of a medicament. Naturally, the toxicity of the compound identified and other well-known factors crucial for the applicability of the compound as a medicament will have to be tested. Methods for developing a suitable active ingredient of a pharmaceutical composition on the basis of the compound identified as a lead compound are described elsewhere in this specification.

Additionally, the invention relates to a method for identifying a compound that specifically binds to a polypeptide having an amino acid sequence selected from the group consisting of SEQ ID NO: 1 [NP\_003961], the amino acid sequence of SEQ ID NO: 2 [41441pep], the amino acid sequence of SEQ ID NO: 3 [56461pep], the amino acid sequence of SEQ ID NO: 4 [AAA52025], the amino acid sequence of SEQ ID NO: 5 [61166pep], the amino acid sequence of SEQ ID NO: 6 [AAD45360], the amino acid sequence of SEQ ID NO: 7 [AAF63623], the amino acid sequence of SEQ ID NO: 8 [66214pep] or the amino acid sequence AAF19343, or the amino acid sequence of SEQ ID NO: 9 [CAA58676]; comprising the steps of (1) providing said polypeptide; and (2) identifying a compound that is capable of binding said polypeptide.

25

Based on the function of these proteins in DCM development a cell based assay can be developed to identify potential inhibitors or activators. The protein under investigation is expressed in cardiomyocytes (e. g. by infection with recombinant adenovirus). The expression of these proteins lead to characteristic morphological alterations. Reversal or reduction of these morphological alterations can be used in a HTS assay to identify

30

compounds which act as inhibitors or activators of these proteins. The system can be automated by use of digital image analysis systems.

Another possibility is to identify first proteins which are binding partners of the claimed proteins. This is especially important for structural proteins or adaptor proteins in signal transduction pathways.

Methods to identify compounds capable of binding are affinity chromatography with immobilised target protein and subsequent elution of bound proteins (e. g. by acid pH), co-immunoprecipitation and as a third method chemical crosslinking with subsequent analysis on SDS-PAGE.

The influence of compounds on these protein-protein interactions can be monitored by techniques like optical spectroscopy (e. g. fluorescence or surface plasmon resonance), calorimetry (isothermal titration microcalorimetry) and NMR. In the case of optical spectroscopy either the intrinsic protein fluorescence may change (in intensity and/or wavelength of emission maximum) upon complex formation with the binding compound or the fluorescence of a covalently attached fluorophore may change upon complex formation.

The claimed protein or its identified binding partner may be labelled on e. g. cysteine or lysine residues with a fluorophore (for a collection of fluorophores see catalogues of Molecular Probes or Pierce Chemical Company) which changes its optical properties upon binding. These changes in the intrinsic or extrinsic fluorescence may be applied for use in a HTS assay to identify compounds capable of inhibiting or activating the mentioned protein-protein interaction.

If the claimed protein exhibits enzymatic activity (e. g. Kinase, Protease, Phosphatase) the inhibition or activation of this activity may be monitored by using labelled (fluorescently, radioactively or immunologically) derivatives of the substrate. This activity assay which is based on labelled substrates can be used for development of a HTS assay to identify compounds acting as inhibitors or activators.

Further the invention relates to a monoclonal antibody or derivative thereof that specifically binds to polypeptide having an amino acid sequence selected from the group consisting of SEQ ID NO: 1 [NP\_003961], the amino acid sequence of SEQ ID NO: 2 [41441pep], the amino acid sequence of SEQ ID NO: 3 [56461pep], the amino acid sequence of SEQ ID

NO: 4 [AAA52025], the amino acid sequence of SEQ ID NO: 5 [61166pep], the amino acid sequence of SEQ ID NO: 6 [AAD45360], the amino acid sequence of SEQ ID NO: 7 [AAF63623], the amino acid sequence of SEQ ID NO: 8 [66214pep] or the amino acid sequence AAF19343, or the amino acid sequence of SEQ ID NO: 9 [CAA58676].

5

Moreover, the invention relates to a method for identifying a compound that increases or decreases the level in heart tissue of an mRNA encoding a polypeptide selected from the group consisting of: (a) the polypeptide having amino acid sequence of SEQ ID NO: 1 [NP\_003961], the amino acid sequence of SEQ ID NO: 2 [41441pep], the amino acid  
10 sequence of SEQ ID NO: 3 [56461pep], the amino acid sequence of SEQ ID NO: 4 [AAA52025], the amino acid sequence of SEQ ID NO: 5 [61166pep], the amino acid sequence of SEQ ID NO: 6 [AAD45360], the amino acid sequence of SEQ ID NO: 7 [AAF63623], the amino acid sequence of SEQ ID NO: 8 [66214pep] or the amino acid sequence AAF19343, or the amino acid sequence of SEQ ID NO: 9 [CAA58676]; (b) a  
15 polypeptide having an amino acid sequence that is at least 60%, preferably at least 80%, especially at least 90%, advantageously at least 99% identical to the amino acid sequence of (a); and (c) a polypeptide having the amino acid sequence of (a) with at least one conservative amino acid substitution, the method comprising the steps of (1) contacting a  
20 DNA giving rise to said mRNA under conditions that would permit transcription of said mRNA with a test compound; and (2) detecting an increased or decreased level of the mRNA relative to the level of transcription obtained in the absence of the test compound.

This embodiment of the invention is very similar to the previously discussed one with the exception that here mRNA levels are detected whereas in the previous embodiment protein levels are detected. Methods of assessing RNA levels which also apply to this embodiment  
25 have been described herein above.

Furthermore, the invention relates to a transgenic non-human mammal whose somatic and germ cells comprise at least one gene encoding a functional or disrupted polypeptide selected from the group consisting of: (a) the polypeptide having the amino acid sequence  
30 SEQ ID NO: 1 [NP\_003961], the amino acid sequence of SEQ ID NO: 2 [41441pep], the amino acid sequence of SEQ ID NO: 3 [56461pep], the amino acid sequence of SEQ ID

NO: 4 [AAA52025], the amino acid sequence of SEQ ID NO: 5 [61166pep], the amino acid sequence of SEQ ID NO: 6 [AAD45360], the amino acid sequence of SEQ ID NO: 7 [AAF63623], the amino acid sequence of SEQ ID NO: 8 [66214pep] or the amino acid sequence AAF19343, or the amino acid sequence of SEQ ID NO: 9 [CAA58676]; (b) a polypeptide having an amino acid sequence that is at least 60%, preferably at least 80%, especially at least 90%, advantageously at least 99% identical to the amino acid sequence of (a); and (c) a polypeptide having the amino acid sequence of (a) with at least one conservative amino acid substitution, that has been modified, said modification being sufficient to decrease or increase the amount of said functional polypeptide expressed in the heart tissue of said transgenic non-human mammal, wherein said transgenic non-human mammal exhibits a disease of the heart.

A method for the production of a transgenic non-human animal, for example transgenic mouse, comprises introduction of the aforementioned polynucleotide or targeting vector into a germ cell, an embryonic cell, stem cell or an egg or a cell derived therefrom. The non-human animal can be used in accordance with a screening method of the invention described herein. Production of transgenic embryos and screening of those can be performed, e.g., as described by A. L. Joyner Ed., *Gene Targeting, A Practical Approach* (1993), Oxford University Press. The DNA of the embryonal membranes of embryos can be analyzed using, e.g., Southern blots with an appropriate probe; see supra. A general method for making transgenic non-human animals is described in the art, see for example WO 94/24274. For making transgenic non-human organisms (which include homologously targeted non-human animals), embryonal stem cells (ES cells) are preferred. Murine ES cells, such as AB-1 line grown on mitotically inactive SNL76/7 cell feeder layers (McMahon and Bradley, *Cell* 62:1073-1085 (1990)) essentially as described (Robertson, E. J. (1987) in *Teratocarcinomas and Embryonic Stem Cells: A Practical Approach*. E. J. Robertson, ed. (Oxford: IRL Press), p. 71-112) may be used for homologous gene targeting. Other suitable ES lines include, but are not limited to, the E14 line (Hooper et al., *Nature* 326:292-295 (1987)), the D3 line (Doetschman et al., *J. Embryol. Exp. Morph.* 87:27-45 (1985)), the CCE line (Robertson et al., *Nature* 323:445-448 (1986)), the AK-7 line (Zhuang et al., *Cell* 77:875-884 (1994)). The success of generating a mouse line from ES cells bearing a specific targeted mutation depends on the pluripotency of the ES cells (i.

e., their ability, once injected into a host developing embryo, such as a blastocyst or morula, to participate in embryogenesis and contribute to the germ cells of the resulting animal). The blastocysts containing the injected ES cells are allowed to develop in the uteri of pseudopregnant nonhuman females and are born as chimeric mice. The resultant transgenic mice are chimeric for cells having either the recombinase or reporter loci and are backcrossed and screened for the presence of the correctly targeted transgene (s) by PCR or Southern blot analysis on tail biopsy DNA of offspring so as to identify transgenic mice heterozygous for either the recombinase or reporter locus/loci.

The transgenic non-human animals may, for example, be transgenic mice, rats, hamsters, dogs, monkeys, rabbits, pigs, or cows. Preferably, said transgenic non-human animal is a mouse.

In a preferred embodiment of the transgenic non-human mammal of the invention said functional or disrupted gene was introduced into the non-human mammal or an ancestor thereof, at an embryonic stage.

In a further preferred embodiment of the transgenic non-human mammal of the invention the modification is inactivation, suppression or activation of said gene(s) or leads to the reduction or enhancement of the synthesis of the corresponding protein(s).

This embodiment allows for example the study of the interaction of various mutant forms of the aforementioned polypeptides on the onset of the clinical symptoms of a disease related to disorders in the heart. All the applications that have been herein before discussed with regard to a transgenic animal also apply to animals carrying two, three or more transgenes for example encoding different aforementioned nucleic acid molecules. It might be also desirable to inactivate protein expression or function at a certain stage of development and/or life of the transgenic animal. This can be achieved by using, for example, tissue specific, developmental and/or cell regulated and/or inducible promoters which drive the expression of, e.g., an antisense or ribozyme directed against the RNA transcript encoding the corresponding RNA; see also supra. A suitable inducible system is for example tetracycline-regulated gene expression as described, e.g., by Gossen and Bujard (Proc. Natl. Acad. Sci. 89 USA (1992), 5547-5551) and Gossen et al. (Trends

Biotech. 12 (1994), 58-62). Similar, the expression of the mutant protein(s) may be controlled by such regulatory elements.

As mentioned, the invention also relates to a transgenic non-human animal, preferably mammal and cells of such animals which cells contain (preferably stably integrated into their genome) at least one of the aforementioned nucleic acid molecule(s) or part thereof, wherein the transcription and/or expression of the nucleic acid molecule or part thereof leads to reduction of the synthesis of (a) corresponding protein(s). In a preferred embodiment, the reduction is achieved by an anti-sense, sense, ribozyme, co-suppression and/or dominant mutant effect. "Antisense" and "antisense nucleotides" means DNA or RNA constructs which block the expression of the naturally occurring gene product.

Techniques how to achieve this are well known to the person skilled in the art. These include, for example, the expression of antisense-RNA, ribozymes, of molecules which combine antisense and ribozyme functions and/or of molecules which provide for a co-suppression effect; see also supra. When using the antisense approach for reduction of the amount of said proteins in cells, the nucleic acid molecule encoding the antisense-RNA is preferably of homologous origin with respect to the animal species used for transformation. However, it is also possible to use nucleic acid molecules which display a high degree of homology to endogenously occurring nucleic acid molecules encoding such a protein. In this case the homology is preferably higher than 60%, preferably higher than 80%, particularly higher than 90%, more preferably higher than 95% and especially higher than 99%.

In cases where more than one of the aforementioned genes are inactivated, interrelationships of gene products in the onset or progression of the diseases of the heart may be assessed. In this regard, it is also of interest to cross transgenic non-human animals having different transgenes for assessing further interrelationships of gene products in the onset or progression of said disease. Consequently, the offspring of such crosses is also comprised by the scope of the present invention.

In addition, the invention relates to a method for identifying in heart issue a compound that increases or decreases the expression of a polypeptide selected from the group consisting of: (a) the polypeptide having amino acid sequence SEQ ID NO: 1 [NP\_003961], the amino acid sequence of SEQ ID NO: 2 [41441pep], the amino acid sequence of SEQ ID NO: 3 [56461pep], the amino acid sequence of SEQ ID NO: 4 [AAA52025], the amino acid sequence of SEQ ID NO: 5 [61166pep], the amino acid sequence of SEQ ID NO: 6 [AAD45360], the amino acid sequence of SEQ ID NO: 7 [AAF63623], the amino acid sequence of SEQ ID NO: 8 [66214pep] or the amino acid sequence AAF19343, or the amino acid sequence of SEQ ID NO: 9 [CAA58676]; (b) a polypeptide having an amino acid sequence that is at least 60%, preferably at least 80%, especially at least 90%, advantageously at least 99% identical to the amino acid sequence of (a); and (c) a polypeptide having the amino acid sequence of (a) with at least one conservative amino acid substitution, said method comprising the steps of: (1) contacting a transgenic non-human mammal as described herein above with a test compound, and (2) detecting an increased/decreased level of expression of said polypeptide relative to the expression in the absence of said test compound.

The test compound which has preferably been tested beforehand for essentially lacking toxicity for the animal can be administered to the animal by any convenient route suitable for administration. These routes include injection, topical and oral administration. Intervals and doses of administration may vary and will be decided upon by the physician/researcher on a case-by-case basis.

Detection, if any, may be effected by a variety of means. For example, if the transgene includes a bioluminescent portion, increase of polypeptide production may be assessed as described, for example, in EP 95 94 1424.4 or in EP 99 12 4640.6. Alternatively, and if the polypeptides are present in the bloodstream, blood of the non-human transgenic animal may be assessed for the changing quantity of the protein. It is preferred in such a case that the gene encoding the polypeptide of interest carries an inducible promoter. Thus, by comparing the situations with and without induction, it can conveniently be determined whether the test compound has indeed an effect on the polypeptide produced or whether the

test compound causes an effect unrelated to the level of polypeptide produced. In certain embodiments of the invention, the non-human transgenic animal will have to be sacrificed in order to assess whether a change in the level of polypeptide expression has occurred. For example, heart tissue may be removed from the sacrificed animal and assessed, using standard technologies, for the expression level of the protein. For example, an antibody specific for the polypeptide may be contacted with the heart tissue and the test developed with a second labeled antibody that is directed to the first antibody. Alternatively, the first antibody itself may be labeled. Heart tissue of a non-human transgenic animal that has been contacted with the test compound would be compared with heart tissue of a non-human transgenic animal that has not been contacted with said test compound.

As mentioned herein above, the transgenic animal may carry more than one of the aforementioned nucleic acid molecules. Accordingly, the effect of a test compound on the expression level of any of these transgenes may be assessed. In addition, a variety of test compounds may be tested, at the same time, for the effect on one or a variety of said transgenes.

A test compound that has proven to be effective in increasing or decreasing the level of the polypeptide of interest and/or in decreasing or increasing the turnover of the polypeptide of interest may be either directly formulated into a medicament (if, for example, its structure is suitable for administration and if it has proven to be non-toxic) or may serve as a lead compound for downstream developments, the results of which may then be formulated into pharmaceutical compositions.

In a preferred embodiment of the method of the invention the test compound prevents or ameliorates a disease of the heart in said transgenic non-human mammal.

In this embodiment, the effect of the test compound may be assessed by observing the disease state of the transgenic animal. Thus, if the animal suffers from a disease of the heart prior to the administration of the test compound and the administration of the test compound results in an amelioration of the disease, then it can be concluded that this test

compound is a prime candidate for the development of a medicament useful also in humans. In addition the compound could also inhibit disease establishment by treatment in advance.

- 5 A further embodiment of the invention is a method for identifying one or a plurality of isogenes of a gene coding for a polypeptide selected from the group consisting of: the amino acid sequence of SEQ ID NO: 1 [NP\_003961], the amino acid sequence of SEQ ID NO: 2 [41441pep], the amino acid sequence of SEQ ID NO: 3 [56461pep], the amino acid sequence of SEQ ID NO: 4 [AAA52025], the amino acid sequence of SEQ ID NO: 5 [61166pep], the amino acid sequence of SEQ ID NO: 6 [AAD45360], the amino acid sequence of SEQ ID NO: 7 [AAF63623], the amino acid sequence of SEQ ID NO: 8 [66214pep] or the amino acid sequence AAF19343, or the amino acid sequence of SEQ ID NO: 9 [CAA58676]; the method comprising the steps of
- 10 (1) providing nucleic acid coding for said polypeptide or a part thereof; and
- 15 (2) identifying a second nucleic acid that (i) has a homology of 60%, preferably 80%, especially 90%, advantageously 99% or (ii) hybridizes in 4xSSC, 0.1 SDS at 45°C to the nucleic acid molecule encoding the amino acid sequence of (a), (c) or (d).

The term isogenes shall mean genes that are thought to be created by gene duplication.

20 They can be identified by comparing the homology of the DNA-, RNA-, or protein-sequence of interest with other DNA, RNA or protein-sequences of the same species from different databases. There might be strong differences in the degree of homology between isogenes of the same species. This may be dependent on the time-point, when the gene duplication event took place in evolution and the degree of conservation during evolution.

25 Isogenes can be identified and cloned by RT-PCR as has been demonstrated by Sreaton *et al.* (1995) EMBO J. 14:4336-4349 or Huang *et al.* (1998) Gene 211: 49-55. Isogenes can also be identified and cloned by colony hybridisation or plaque hybridization as described in Sambrook, Fritsch, Maniatis (1989), Molecular Cloning. Cold Spring Harbor Laboratory Press. In a first step, either a genomic or a cDNA library in bacteria or phages is generated.

30 In order to identify isogenes, colony hybridisation or plaque hybridization is slightly

modified in a way that cross-hybridizations are detectable under conditions of lower stringency. This can be achieved by lowering the calculated temperature for hybridisation and washing and/or by lowering the salt concentration of the washing solutions (Sambrook, Fritsch, Maniatis (1989) Cold Spring Harbor Laboratory Press). For example, a low-stringency washing condition may include 2 wash steps at a temperature between 45°C and 5 65°C with 4xSSC, 0,1% SDS for 30 min (50 ml) and finally two wash steps with 50 ml of a solution containing 2xSSC, 0.1% SDS for 30 min. After detection, signal intensity of colonies containing an isogene is dependent on the homology of a gene and its isogene(s).

10 Furthermore, the invention relates to a method for identifying one or a plurality of genes whose expression in heart tissue is modulated by inhibiting, decreasing or increasing the expression of a polypeptide selected from the group consisting of: (a) the polypeptide having amino acid sequence SEQ ID NO: 1 [NP\_003961], the amino acid sequence of SEQ ID NO: 2 [41441pep], the amino acid sequence of SEQ ID NO: 3 [56461pep], the amino acid sequence of SEQ ID NO: 4 [AAA52025], the amino acid sequence of SEQ ID NO: 5 15 [61166pep], the amino acid sequence of SEQ ID NO: 6 [AAD45360], the amino acid sequence of SEQ ID NO: 7 [AAF63623], the amino acid sequence of SEQ ID NO: 8 [66214pep] or the amino acid sequence AAF19343, or the amino acid sequence of SEQ ID NO: 9 [CAA58676]; (b) a polypeptide having an amino acid sequence that is at least 60%, preferably at least 80%, especially at least 90%, advantageously at least 99% identical to the amino acid sequence of (a); and (c) a polypeptide having the amino acid sequence of (a) with at least one conservative amino acid substitution, or of an mRNA encoding said polypeptide, said modulation being indicative of a disease of the heart, said method comprising the steps of: (1) contacting a plurality of heart tissue cells with a compound that 20 inhibits, decreases or increases the expression of said polypeptide under conditions that permit the expression of said polypeptide in the absence of a test compound, and (2) comparing a gene expression profile of said heart cell in the presence and in the absence of said compound.

The term "gene expression profile" shall mean all expressed genes of a cell or a tissue.

30 Such profile can be assessed using the methods well known in the art, for example isolation of total RNA, isolation of poly(A) RNA from total RNA, suppression subtractive

hybridization, differential display, preparation of cDNA libraries or quantitative dot blot analysis, as for example described in Example 1 of this application.

This embodiment of the method of the invention is particularly suitable for identifying further genes the expression level of which is directly affected by the aberrant expression of any of the aforementioned genes. In other words, this embodiment of the method of the invention allows the identification of genes involved in the same protein cascade as the aberrantly expressed gene. Typically, the method of the invention will be a method performed in cell culture.

10 The method of the invention allows for the design of further medicaments that use other targets than the aberrantly expressed gene. For example, if a potential target downstream of the aberrantly expressed gene is indeed targeted by a medicament, the negative effect of the aberrantly expressed gene may be efficiently counterbalanced. Compounds modulating other genes in the cascade may have to be refined or further developed prior to administration as a medicament as described elsewhere in this specification.

15 Additionally, the invention relates to a method for identifying one or a plurality of genes whose expression in heart tissue is modulated by the inhibition, decreasing or increasing of the expression of a polypeptide selected from the group consisting of: (a) the polypeptide having amino acid sequence SEQ ID NO: 1 [NP\_003961], the amino acid sequence of SEQ ID NO: 2 [41441pep], the amino acid sequence of SEQ ID NO: 3 [56461pep], the amino acid sequence of SEQ ID NO: 4 [AAA52025], the amino acid sequence of SEQ ID NO: 5 [61166pep], the amino acid sequence of SEQ ID NO: 6 [AAD45360], the amino acid sequence of SEQ ID NO: 7 [AAF63623], the amino acid sequence of SEQ ID NO: 8 [66214pep] or the amino acid sequence AAF19343, or the amino acid sequence of SEQ ID NO: 9 [CAA58676]; (b) a polypeptide having an amino acid sequence that is at least 60%, preferably at least 80%, especially at least 90%, advantageously at least 99% identical to the amino acid sequence of (a); and (c) a polypeptide having the amino acid sequence of (a) with at least one conservative amino acid substitution, or of an mRNA encoding said polypeptide, said modulation being indicative of a disease of the heart, said method comprising the steps of: (1) providing expression profiles of (i) a plurality of heart tissue cells from or derived from a heart of a subject suffering from a disease of the heart; and (ii)

a plurality of heart tissue cells from or derived from a subject not suffering from a disease of the heart; and (2) comparing the expression profiles (i) and (ii).

5 In variation to the method described herein above, this embodiment of the method of the invention compares the expression profiles of cells from a healthy subject and a subject suffering from a heart disease. In this regard, the term "cells derived from a heart" includes cells that are held in cell culture or even cell lines that autonomously grow in cell culture and that were originally derived from heart tissue. By comparing the two expression profiles, differences in expression levels of genes involved in the disease of the heart may be identified. As with the preceding embodiment, these genes may be part of a cascade involving the aberrantly expressed gene. Examples of such cascades are signaling cascades. Once genes are identified that are expressed at a different level in a diseased heart, they may be tested up-regulation or down-regulation by bringing them into contact with suitable test compounds. Again, these test compounds may then, with or without further development, be formulated into pharmaceutical compositions.

10  
15

In a preferred embodiment, the method of the invention further comprises the steps of (3) determining at least one gene that is expressed at a lower or higher level in the presence of said compound; and (4) identifying a further compound that is capable of raising or lowering the expression level of said at least one gene.

20

This preferred embodiment of the invention requires that one of the genes the expression of which may directly or indirectly be lowered or increased by the expression of the aberrant gene is identified. Then, a further panel of test compounds may be tested for the capacity to increase or decrease the expression of said further gene. Compounds that are successfully tested would be prime candidates for the development of medicaments for the prevention or treatment of a disease of the heart.

25

In another preferred embodiment, the method of the invention further comprises the steps of (3) determining at least one gene that is expressed at a lower or higher level in said heart tissue cells from or derived from a heart of a subject suffering from a disease of the heart;

30

and (4) identifying a further compound that is capable of raising or lowering the expression level of said at least one gene.

5 In variation of the previously discussed embodiment, this embodiment requires that at least one gene is identified by comparing the expression profiles of tissue or cells derived from a healthy subject and from a subject suffering from a disease of the heart. Subsequently, at least one compound is identified that is capable of increasing or decreasing the expression of said gene.

10 In yet another preferred embodiment, the method of the invention further comprises the steps of (3) determining at least one gene that is expressed at a higher or lower level in the presence of said compound; and (4) identifying a further compound that is capable of reducing or raising the expression level of said at least one gene.

15 In this and the following embodiment, the situation is covered that another gene in the cascade that also includes the aberrantly expressed gene has a higher or lower expression level that needs to be lowered or raised in order to effectively treat the disease of the heart. Again, once such a gene is identified, a compound is tested for its capacity to lower expression of said gene.

20

In still another preferred embodiment, the method of the invention further comprises the steps of (3) determining at least one gene that is expressed at a higher or lower level in said heart tissue cells from or derived from a heart of a subject suffering from a disease of the heart; and (4) identifying a further compound that is capable of reducing or enhancing the expression level of said at least one gene.

25

Additionally, the invention relates to a method for identifying proteins or a plurality of proteins whose activity is modulated by a polypeptide having the amino acid sequence selected from the group consisting of SEQ ID NO: 1 [NP 003961], the amino acid  
30 sequence of SEQ ID NO: 2 [41441pep], the amino acid sequence of SEQ ID NO: 3 [56461pep], the amino acid sequence of SEQ ID NO: 4 [AAA52025], the amino acid

sequence of SEQ ID NO: 5 [61166pep], the amino acid sequence of SEQ ID NO: 6 [AAD45360], the amino acid sequence of SEQ ID NO: 7 [AAF63623], the amino acid sequence of SEQ ID NO: 8 [66214pep] or the amino acid sequence AAF19343, or the amino acid sequence of SEQ ID NO: 9 [CAA58676]; the method comprising the steps of  
5 (1) providing said polypeptide and (2) identifying a further protein that is capable of interacting with said polypeptide.

One possible method to identify protein-protein interactions is the Yeast two-hybrid screen described by Golemis & Khazak (1997), *Methods Mol Biol.* 63:197-218. Other well  
10 established methods in order to identify protein-protein interactions are co-immunoprecipitations or in *vitro* protein interaction assays like GST-pulldown assays (such as described in Stoss, Schwaiger, Cooper and Stamm (1999). *J. Biol. Chem.* 274: 10951-10962).

15 In a further preferred embodiment of the method of the invention said compound is a small molecule or a peptide derived from an at least partially randomized peptide library.

Additionally, the invention relates to a method of refining a compound identified by the method as described herein above comprising the steps of (1) identification of the binding  
20 sites of the compound and the DNA or mRNA molecule by site-directed mutagenesis or chimeric protein studies; (2) identification of the binding-site of said polypeptide and the compound by site-directed mutagenesis of the corresponding DNA or by chimeric protein studies, (3) molecular modeling of both the binding site of the compound and the binding site of the DNA or mRNA molecule; and (4) modification of the compound to improve its  
25 binding specificity for the DNA or mRNA.

All techniques employed in the various steps of the method of the invention are conventional or can be derived by the person skilled in the art from conventional techniques without further ado. Thus, biological assays based on the herein identified nature of the  
30 polypeptides may be employed to assess the specificity or potency of the drugs wherein the increase of one or more activities of the polypeptides may be used to monitor said

specificity or potency. Steps (1) and (2) can be carried out according to conventional protocols. A protocol for site directed mutagenesis is described in Ling MM, Robinson BH. (1997) Anal. Biochem. 254: 157-178. The use of homology modelling in conjunction with site-directed mutagenesis for analysis of structure-function relationships is reviewed in Szklarz and Halpert (1997) Life Sci. 61:2507-2520. Chimeric proteins are generated by ligation of the corresponding DNA fragments via a unique restriction site using the conventional cloning techniques described in Sambrook, Fritsch, Maniatis. Molecular Cloning, a laboratory manual. (1989) Cold Spring Harbor Laboratory Press. A fusion of two DNA fragments that results in a chimeric DNA fragment encoding a chimeric protein can also be generated using the gateway-system (Life technologies), a system that is based on DNA fusion by recombination. A prominent example of molecular modelling is the structure-based design of compounds binding to HIV reverse transcriptase that is reviewed in Mao, Sudbeck, Venkatachalam and Uckun (2000). Biochem. Pharmacol. 60: 1251-1265.

For example, identification of the binding site of said drug by site-directed mutagenesis and chimerical protein studies can be achieved by modifications in the (poly)peptide primary sequence that affect the drug affinity; this usually allows to precisely map the binding pocket for the drug.

As regards step (2), the following protocols may be envisaged: Once the effector site for drugs has been mapped, the precise residues interacting with different parts of the drug can be identified by combination of the information obtained from mutagenesis studies (step (1)) and computer simulations of the structure of the binding site provided that the precise three-dimensional structure of the drug is known (if not, it can be predicted by computational simulation). If said drug is itself a peptide, it can be also mutated to determine which residues interact with other residues in the polypeptide of interest.

Finally, in step (3) the drug can be modified to improve its binding affinity or its potency and specificity. If, for instance, there are electrostatic interactions between a particular residue of the polypeptide of interest and some region of the drug molecule, the overall charge in that region can be modified to increase that particular interaction.

Identification of binding sites may be assisted by computer programs. Thus, appropriate

computer programs can be used for the identification of interactive sites of a putative inhibitor and the polypeptide by computer assisted searches for complementary structural motifs (Fassina, *Immunomethods* 5 (1994), 114-120). Further appropriate computer systems for the computer aided design of protein and peptides are described in the prior art, for example, in Berry, *Biochem. Soc. Trans.* 22 (1994), 1033-1036; Wodak, *Ann. N. Y. Acad. Sci.* 501 (1987), 1-13; Pabo, *Biochemistry* 25 (1986), 5987-5991. Modifications of the drug can be produced, for example, by peptidomimetics and other inhibitors can also be identified by the synthesis of peptidomimetic combinatorial libraries through successive chemical modification and testing the resulting compounds. Methods for the generation and use of peptidomimetic combinatorial libraries are described in the prior art, for example in Ostresh, *Methods in Enzymology* 267 (1996), 220-234 and Dorner, *Bioorg. Med. Chem.* 4 (1996), 709-715. Furthermore, the three-dimensional and/or crystallographic structure of activators of the expression of the polypeptide of the invention can be used for the design of peptidomimetic activators, e.g., in combination with the (poly)peptide of the invention (Rose, *Biochemistry* 35 (1996), 12933-12944; Rutenber, *Bioorg. Med. Chem.* 4 (1996), 1545-1558).

In accordance with the above, in a preferred embodiment of the method of the invention said compound is further refined by peptidomimetics.

20

The invention furthermore relates to a method of modifying a compound identified or refined by the method as described herein above as a lead compound to achieve (1) modified site of action, spectrum of activity, organ specificity, and/or (2) improved potency, and/or (3) decreased toxicity (improved therapeutic index), and/or (4) decreased side effects, and/or (5) modified onset of therapeutic action, duration of effect, and/or (6) modified pharmacokinetic parameters (resorption, distribution, metabolism and excretion), and/or (7) modified physico-chemical parameters (solubility, hygroscopicity, color, taste, odor, stability, state), and/or (8) improved general specificity, organ/tissue specificity, and/or (9) optimized application form and route by (i) esterification of carboxyl groups, or (ii) esterification of hydroxyl groups with carbon acids, or (iii) esterification of hydroxyl groups to, e.g. phosphates, pyrophosphates or sulfates or hemi succinates, or (iv) formation

30

of pharmaceutically acceptable salts, or (v) formation of pharmaceutically acceptable complexes, or (vi) synthesis of pharmacologically active polymers, or (vii) introduction of hydrophylic moieties, or (viii) introduction/exchange of substituents on aromates or side chains, change of substituent pattern, or (ix) modification by introduction of isosteric or bioisosteric moieties, or (x) synthesis of homologous compounds, or (xi) introduction of branched side chains, or (xii) conversion of alkyl substituents to cyclic analogues, or (xiii) derivatisation of hydroxyl group to ketales, acetals, or (xiv) N-acetylation to amides, phenylcarbamates, or (xv) synthesis of Mannich bases, imines, or (xvi) transformation of ketones or aldehydes to Schiff's bases, oximes, acetals, ketales, enolesters, oxazolidines, thiozolidines or combinations thereof.

The various steps recited above are generally known in the art. They include or rely on quantitative structure-action relationship (QSAR) analyses (Kubinyi, "Hausch-Analysis and Related Approaches", VCH Verlag, Weinheim, 1992), combinatorial biochemistry, classical chemistry and others (see, for example, Holzgrabe and Bechtold, Deutsche Apotheker Zeitung 140(8), 813-823, 2000).

The invention additionally relates to a method for inducing a disease of the heart in a non-human mammal, comprising the step of contacting the heart tissue of said mammal with a compound that inhibits, decreases or increases the expression of a polypeptide selected from the group consisting of: (a) the polypeptide having amino acid sequence SEQ ID NO: 1 [NP\_003961], the amino acid sequence of SEQ ID NO: 2 [41441pep], the amino acid sequence of SEQ ID NO: 3 [56461pep], the amino acid sequence of SEQ ID NO: 4 [AAA52025], the amino acid sequence of SEQ ID NO: 5 [61166pep], the amino acid sequence of SEQ ID NO: 6 [AAD45360], the amino acid sequence of SEQ ID NO: 7 [AAF63623], the amino acid sequence of SEQ ID NO: 8 [66214pep] or the amino acid sequence AAF19343, or the amino acid sequence of SEQ ID NO: 9 [CAA58676]; (b) a polypeptide having an amino acid sequence that is at least 60%, preferably at least 80%, especially at least 90%, advantageously at least 99% identical to the amino acid sequence of (a); and (c) a polypeptide having the amino acid sequence of (a) with at least one conservative amino acid substitution.

This embodiment of the invention is particularly useful for mimicking factors/developments leading to the onset of the disease. The fact, that differences in the expression of a protein contributes to heart failure has been shown for phospholamban, for example. Mice over-expressing phospholamban develop heart failure. This effect is thought to be due to the inhibition of Serca. (Minamisawa et al. (1999) Cell, 99:313-322).

In a preferred embodiment of the method of the invention said compound that decreases or increases is a small molecule, an antibody or an aptamer that specifically binds said polypeptide.

The terms "small molecule" as well as "antibody" have been described herein above and bear the same meaning in connection with this embodiment.

The invention moreover relates to a method of producing a pharmaceutical composition comprising formulating the compound identified, refined or modified by the method as described herein above, optionally with a pharmaceutically active carrier and/or diluent.

The pharmaceutical composition of the present invention may further comprise a pharmaceutically acceptable carrier and/or diluent. Examples of suitable pharmaceutical carriers are well known in the art and include phosphate buffered saline solutions, water, emulsions, such as oil/water emulsions, various types of wetting agents, sterile solutions etc. Compositions comprising such carriers can be formulated by well known conventional methods. These pharmaceutical compositions can be administered to the subject at a suitable dose. Administration of the suitable compositions may be effected by different ways, e.g., by intravenous, intraperitoneal, subcutaneous, intramuscular, topical, intradermal, intranasal or intrabronchial administration. The dosage regimen will be determined by the attending physician and clinical factors. As is well known in the medical arts, dosages for any one patient depends upon many factors, including the patient's size, body surface area, age, the particular compound to be administered, sex, time and route of administration, general health, and other drugs being administered concurrently. A typical dose can be, for example, in the range of 0.001 to 1000  $\mu\text{g}$  (or of nucleic acid for

expression or for inhibition of expression in this range); however, doses below or above this exemplary range are envisioned, especially considering the aforementioned factors. Generally, the regimen as a regular administration of the pharmaceutical composition should be in the range of 1  $\mu$ g to 10 mg units per day. If the regimen is a continuous  
5 infusion, it should also be in the range of 1  $\mu$ g to 10 mg units per kilogram of body weight per minute, respectively. Progress can be monitored by periodic assessment. Dosages will vary but a preferred dosage for intravenous administration of DNA is from approximately 10<sup>6</sup> to 10<sup>12</sup> copies of the DNA molecule. The compositions of the invention may be administered locally or systemically. Administration will generally be parenterally, e.g.,  
10 intravenously; DNA may also be administered directly to the target site, e.g., by biolistic delivery to an internal or external target site or by catheter to a site in an artery. Preparations for parenteral administration include sterile aqueous or non-aqueous solutions, suspensions, and emulsions. Examples of non-aqueous solvents are propylene glycol, polyethylene glycol, vegetable oils such as olive oil, and injectable organic esters such as  
15 ethyl oleate. Aqueous carriers include water, alcoholic/aqueous solutions, emulsions or suspensions, including saline and buffered media. Parenteral vehicles include sodium chloride solution, Ringer's dextrose, dextrose and sodium chloride, lactated Ringer's, or fixed oils. Intravenous vehicles include fluid and nutrient replenishers, electrolyte replenishers (such as those based on Ringer's dextrose), and the like. Preservatives and  
20 other additives may also be present such as, for example, antimicrobials, anti-oxidants, chelating agents, and inert gases and the like. Furthermore, the pharmaceutical composition of the invention may comprise further agents such as interleukins or interferons depending on the intended use of the pharmaceutical composition.

The invention also relates to a method for preventing or treating a disease of the heart in a  
25 subject in need of such treatment, comprising the step of increasing or decreasing the level of a polypeptide selected from the group consisting of: (a) the polypeptide having amino acid sequence SEQ ID NO: 1 [NP\_003961], the amino acid sequence of SEQ ID NO: 2 [41441pep], the amino acid sequence of SEQ ID NO: 3 [56461pep], the amino acid sequence of SEQ ID NO: 4 [AAA52025], the amino acid sequence of SEQ ID NO: 5  
30 [61166pep], the amino acid sequence of SEQ ID NO: 6 [AAD45360], the amino acid

sequence of SEQ ID NO: 7 [AAF63623], the amino acid sequence of SEQ ID NO: 8 [66214pep] or the amino acid sequence AAF19343, or the amino acid sequence of SEQ ID NO: 9 [CAA58676]; (b) a polypeptide having an amino acid sequence that is at least 60%, preferably at least 80%, especially at least 90%, advantageously at least 99% identical to the amino acid sequence of (a); and (c) a polypeptide having the amino acid sequence of (a) with at least one conservative amino acid substitution, in the heart tissue of the subject.

Further, the invention relates to a method of preventing or treating a disease of the heart in a subject in need of such treatment comprising the step of increasing or decreasing the level of mRNA encoding a polypeptide selected from the group consisting of: (a) the polypeptide having amino acid sequence SEQ ID NO: 1 [NP\_003961], the amino acid sequence of SEQ ID NO: 2 [41441pep], the amino acid sequence of SEQ ID NO: 3 [56461pep], the amino acid sequence of SEQ ID NO: 4 [AAA52025], the amino acid sequence of SEQ ID NO: 5 [61166pep], the amino acid sequence of SEQ ID NO: 6 [AAD45360], the amino acid sequence of SEQ ID NO: 7 [AAF63623], the amino acid sequence of SEQ ID NO: 8 [66214pep] or the amino acid sequence AAF19343, or the amino acid sequence of SEQ ID NO: 9 [CAA58676]; (b) a polypeptide having an amino acid sequence that is at least 60%, preferably at least 80%, especially at least 90%, advantageously at least 99% identical to the amino acid sequence of (a); and (c) a polypeptide having the amino acid sequence of (a) with at least one conservative amino acid substitution, in the heart tissue of the subject.

The invention in a preferred embodiment relates to a method wherein such increase/decrease is effected by administering the pharmaceutical composition obtained by the method as described herein above.

In a further preferred embodiment of the method of the invention such an increase/decrease is effected by introducing the DNA sequence recited herein above into the germ line or into somatic cells of a subject in need thereof.

Technologies for effecting such an introduction have been described herein above.

In a most preferred embodiment of the method of the invention, the disease of the heart to be treated is congestive heart failure, dilative cardiomyopathy, hypertrophic

cardiomyopathy, ischemic cardiomyopathy, specific heart muscle disease, rhythm and conduction disorders, syncope and sudden death, coronary heart disease, systemic arterial hypertension, pulmonary hypertension and pulmonary heart disease, valvular heart disease, congenital heart disease, pericardial disease or endocarditis.

5

In addition, the invention relates to a method for identifying subjects at risk for heart diseases, especially congestive heart failure comprising the step of detecting an increased level of MYOM2, the LIM domain, the muscle isoform of creatine kinase, YAP65, APOBEC-2, SMPX or C-193 (CARP) in the heart tissue of a subject.

10

The invention additionally relates to a method for preventing or treating heart diseases, especially congestive heart failure in a subject, said method comprising the step of contacting the heart tissue of said subject with a compound that decreases or increases the expression of MYOM2, the LIM domain, the muscle isoform of creatine kinase, YAP65, APOBEC-2, SMPX or C-193 (CARP).

15

In addition the invention relates to a method for identifying subjects at risk for heart diseases, especially congestive heart failure comprising the step of detecting decreased creatine kinase activity in the tissue of a subject, especially in a muscle tissue or from blood or serum. One possible method to detect the activity of creatine kinase would be a conventional kinetic UV-test as described by the International Federation of Clinical Chemistry and Laboratory Medicine (IFCC), 1991.

20

Moreover the invention relates to a method for identifying a subject at risk for heart diseases, especially congestive heart failure, said method comprising detecting increased levels of creatine phosphate in a subject, especially in the blood or serum of a subject.

25

The invention as well relates to a method for preventing or treating heart diseases, especially congestive heart failure in a subject, said method comprising the step of increasing the transfer of phosphoryl groups from creatine phosphate to ADP in the tissue of a subject, especially in a muscle tissue.

30

In a preferred embodiment of the method of the invention the activity of creatine kinase is increased in said tissue.

- 5 The invention additionally relates to a method for identifying a compound for preventing or treating heart diseases, especially congestive heart failure, said method comprising the steps of (a) contacting creatine kinase with a substrate for creatine kinase and a test compound, and (b) determining whether the transfer of phosphoryl groups from the substrate is increased in the presence of the test compound.

10

The figures show:

Fig. 1 a shows the cDNA sequence of clone 40399 (corresponds to SEQ ID NO: 20).

- 15 Fig. 1 b shows the sequence of the EST clone NM\_003970. Start and stop codons are marked by bold letters, the sequence of 40399 is marked in italic letters (corresponds to SEQ ID NO: 10).

20 Fig. 1 c shows the putative amino acid sequence M-PROTEIN (MYOMESIN) 2 (MYOM2) (corresponds to SEQ ID NO: 1).

25 Fig. 1 d shows a schematic alignment of the cDNA fragment 40399 identified in SSH with its homologous Genbank entree and the open reading frame of 1465 amino acids (aa). Not to scale. Homology scores were determined using blast2 algorithm of NCBI:  
40399-NM\_003970: Expect = 2e-88, Identities = 187/194 (96%), Positives = 187/194 (96%).

30 Fig. 1 e: Two filters were hybridized sequentially with [ $\alpha$ -33P]UTP labeled T3 transcripts from cDNA libraries prepared from mRNA of five control and

four DCM heart tissues as indicated. Experiments were normalized by adjusting the overall signal intensity of each hybridization to 100%, relative expression levels are given. A mean value and standard deviation was calculated from all NF samples and DCM sample 15 and 13, respectively. Asterisks mark samples used for SSH.

Fig. 2 a shows the cDNA sequence of clone 41441 (corresponds to SEQ ID NO: 2).

Fig. 2 b shows the sequence of the EST clone AW755252 (corresponds to SEQ ID NO: 11). Start and stop codons are marked in bold letters, the sequence of 41441 is given in italic letters.

Fig. 2 c shows the amino acid sequence 41441pep (corresponds to SEQ ID NO: 21). The first methionine of the open reading frame is marked in bold letters. Amino acids 11-62 of 41441pep encode a cysteine-rich LIM domain (PS00478, PS50023), which is composed of 2 special zinc fingers that are joined by a 2-amino acid spacer (consensus:

CX2CX15-21[FYWH]HX2[CH]X2CX2CX3[LIVMF]XnCX2H as

underlined). According to this analyses, we expect the start codon to be further upstream of the first methionine in frame 1 assuming that a sequencing error exists in the 5' region of AW755252.

Fig. 2 d shows a schematic alignment of the cDNA fragment 41441 identified in SSH with its homologous Genbank entree and the predicted open reading frame. Not to scale. Homology scores were determined using blast2 algorithm of NCBI:

41441-AW755252: Expect = 0.0, Identities = 369/385 (95%), Positives = 369/385 (95%), Gaps = 2/385 (0%)

Fig. 2 e: Two filters were hybridized sequentially with [ $\alpha$ -<sup>33</sup>P]UTP labeled T3 transcripts from cDNA libraries prepared from mRNA of five control and four DCM heart tissues as indicated. Experiments were normalized by adjusting the overall signal intensity of each hybridization to 100%, relative expression levels are given. Mean values and standard deviations were calculated from all NF and DCM samples, respectively. Asterisks mark samples used for SSH.

Fig. 3 a shows the cDNA sequence of clone 52706 (corresponds to SEQ ID NO: 12).

Fig. 3 b: Two filters were hybridized sequentially with [ $\alpha$ -<sup>33</sup>P]UTP labeled T3 transcripts from cDNA libraries prepared from mRNA of five control, and five DCM heart tissues as indicated. Experiments were normalized by adjusting the overall signal intensity of each hybridization to 100%, relative expression levels are given.

Fig. 4 a shows the cDNA sequence of clone 56461 (corresponds to SEQ ID NO: 13).

Fig. 4 b shows the sequence of the EST clone AF077035 (corresponds to SEQ ID NO: 22). Start and stop codons are marked in bold letters, the sequence of 56461 is marked in italic letters.

Fig. 4 c shows the putative amino acid sequence AAD27768 (corresponds to SEQ ID NO: 3). The first methionine of the open reading frame is marked in bold letters. Amino acids 27-79 of 56461 are highly homologous to the rRNA binding motif of 30S ribosomal protein S17 and 40S ribosomal protein S11 (PD001295). A cleavage site for mitochondrial presequences may be predicted for amino acids 57-61 KRK|TY (R2-motif).

Fig. 4 d shows a schematic alignment of the cDNA fragment 56461 identified in SSH with its homologous Genbank entree and the open reading frame of 130 amino acids (aa). Not to scale. Homology scores were determined using blast2 algorithm of NCBI:

5 56461-AF077035: Expect = 0.0, Identities = 498/502 (99%), Positives = 498/502 (99%), Gaps = 2/502 (0%).

Fig. 4 e: Two filters were hybridized sequentially with [ $\alpha$ -33P]UTP labeled T3 transcripts from cDNA libraries prepared from mRNA of five control and  
10 five DCM heart tissues as indicated. Experiments were normalized by adjusting the overall signal intensity of each hybridization to 100%, relative expression levels are given. A mean value and standard deviation was calculated from all NF samples and DCM15 and DCM13, respectively.

15 Fig. 5 a shows the cDNA sequence of clone 61105 (corresponds to SEQ ID NO: 23).

Fig. 5 b shows the sequence of the EST clone M14780 (corresponds to SEQ ID NO: 14). Start and stop codons are marked by bold letters, the sequence of 61105 is marked in italic letters.

20

Fig. 5 c shows the putative amino acid sequence AAA52025 (corresponds to SEQ ID NO: 4).

Fig. 5 d shows a schematic alignment of the cDNA fragment 61105 identified in SSH with its homologous Genbank entree and open reading frame of 381 amino  
25 acids (aa). Not to scale. Homology scores were determined using blast2 algorithm of NCBI:

61105-M14780: Expect = 0.0, Identities = 375/379 (98%), Positives = 375/379 (98%), Gaps = 1/379 (0%).

30

- Fig. 5 e: Two filters were hybridized sequentially with [ $\alpha$ -33P]UTP labeled T3 transcripts from cDNA libraries prepared from mRNA of five control heart tissues and five DCM heart tissues as indicated. Experiments were normalized by adjusting the overall signal intensity of each hybridization to 100%, relative expression levels are given. Mean values and standard deviations were calculated from relative expression levels.
- Fig. 6 a shows the cDNA sequence of clone 61166 (corresponds to SEQ ID NO: 24).
- Fig. 6 b shows the sequence 61166contig assembled from overlapping EST sequences, which are available from public databases (corresponds to SEQ ID NO: 15). Start and stop codons are marked by bold letters, the sequence of 61166 is marked in italic letters.
- Fig. 6 c shows the amino acid sequence of 61166pep (corresponds to SEQ ID NO: 5) Amino acids 40-46 of 61166pep encode a nuclear localization signal pattern 7 (PX1-3[KR][KR][KR], underlined) not present in human YAP65 (NP\_006097). Therefore this protein is expected to be located in the nucleus.
- Fig. 6 d shows a schematic alignment of the cDNA fragment 61166 identified in SSH with its overlapping contig of assembled EST sequences according to LabOnWeb (Compugen) analysis, accession numbers of homologous Genbank entrees and the longest open reading frame of 398 amino acids (aa). Not to scale. Homology scores were determined using blast2 algorithm of NCBI:
- Contig-61166: Expect = 0.0, Identities = 401/403 (99%), Positives = 401/403 (99%), Gaps = 1/403 (0%)
- Contig-AL050107: Expect = 0.0, Identities = 3058/3098 (98%), Positives = 3058/3098 (98%)

Contig-AI927050: Expect = 0.0, Identities = 532/532 (100%), Positives = 532/532 (100%)

Contig-AI745235: Expect = 0.0, Identities = 557/573 (97%), Positives = 557/573 (97%), Gaps = 1/573 (0%).

5

Fig. 6 e: Two filters were hybridized sequentially with [ $\alpha$ -33P]UTP labeled T3 transcripts from cDNA libraries prepared from mRNA of five control heart tissues and five DCM heart tissues as indicated. Experiments were normalized by adjusting the overall signal intensity of each hybridization to 100%, relative expression levels are given. Mean values and standard deviations are given on the right side. Asterisks mark samples used for SSH.

10

Fig. 7 a shows the cDNA sequence of clone 61244 (corresponds to SEQ ID NO: 25).

15

Fig. 7 b shows the sequence of the EST clone AF161698 (corresponds to SEQ ID NO: 16). Start and stop codons are marked by bold letters, the sequence of 61244 is marked in italic letters.

20

Fig. 7 c shows the putative amino acid sequence AAD45360 (corresponds to SEQ ID NO: 6).

Fig. 7 d shows a schematic alignment of the cDNA fragment 61244 identified in SSH with its homologous Genbank entry and open reading frame of 224 amino acids (aa). Not to scale. Homology scores were determined using blast2 algorithm of NCBI:

25

61244-AF161698: Expect = 3e-86, Identities = 168/168 (100%), Positives = 168/168 (100%).

30

Fig. 7 e: Two filters were hybridized sequentially with [ $\alpha$ -33P]UTP labeled T3 transcripts from cDNA libraries prepared from mRNA of five control heart

tissues and five DCM heart tissues as indicated. Experiments were normalized by adjusting the overall signal intensity of each hybridization to 100%, relative expression levels are given. Mean values and standard deviations were calculated from relative expression levels. Asterisks mark samples used for SSH.

5

Fig. 8 a shows the cDNA sequence of clone 65330 (corresponds to SEQ ID NO: 26).

Fig. 8 b shows the contig of assembled EST sequences (corresponds to SEQ ID NO: 17). Start and stop codons are marked by bold letters, the sequence of 65330 is marked in italic letters.

10

Fig. 8 c shows the putative amino acid sequence of clone 65330 (corresponds to SEQ ID NO: 7).

15

Fig. 8 d shows a schematic alignment of the cDNA fragment 65330 identified in SSH with its overlapping contig of assembled EST sequences according to LabOnWeb (Compugen) analysis, accession numbers of homologous Genbank entree and the longest open reading frame of 264 amino acids (aa). Not to scale. Homology scores were determined using blast2 algorithm of NCBI:

20

Contig-65330: Expect = 0.0, Identities = 334/334 (100%), Positives = 334/334 (100%)

Contig-AF249873: Expect = 0.0, Identities = 1020/1028 (99%), Positives = 1020/1028 (99%).

25

Fig. 8 e: Two filters were hybridized sequentially with [ $\alpha$ -33P]UTP labeled T3 transcripts from cDNA libraries prepared from mRNA of five control, five DCM and two ICM heart tissues as indicated. Experiments were normalized

by adjusting the overall signal intensity of each hybridization to 100%, relative expression levels are given.

Fig. 9 a shows the cDNA sequence of clone 66214 (corresponds to SEQ ID NO: 27).

5

Fig. 9 b shows the sequence of the EST clone 66214cds (corresponds to SEQ ID NO: 18). The poly(A) signal is underlined, start and stop codons are marked by bold letters, the sequence of 66214 is marked in italic letters.

10 Fig. 9 c shows the putative amino acid sequence 66214pep (corresponds to SEQ ID NO: 8).

Fig. 9 d shows a schematic alignment of the cDNA fragment 66214 identified in SSH with the Genbank entree and open reading frame of 88 amino acids (aa). Not to scale. Homology scores were determined using blast2 algorithm of NCBI: 66214-AF129505: Expect = e-157, Identities = 290/290 (100%), Positives = 290/290 (100%).

15

Fig. 9 e: Two filters were hybridized sequentially with [ $\alpha$ -33P]UTP labeled T3 transcripts from cDNA libraries prepared from mRNA of five control and five DCM heart tissues as indicated. Experiments were normalized by adjusting the overall signal intensity of each hybridization to 100%, relative expression levels are given. NF1 was not taken into account for calculation of mean values and standard deviations.

20

25 Fig. 10 a shows the cDNA sequence of clone 66268 (corresponds to SEQ ID NO: 28), 52474 (corresponds to SEQ ID NO: 29) and S1MC01-1 (corresponds to SEQ ID NO: 30).

Fig. 10 b shows the sequence of the EST clone X83703 (corresponds to SEQ ID NO: 19). Start and stop codons are marked by bold letters, the sequences of 66268 and S1MC01-1 are marked in italic letters. Multiple AU-rich mRNA decay elements are present in the 3'-noncoding region (underlined).

5

Fig. 10 c shows the putative amino acid sequence CAA58676 (corresponds to SEQ ID NO: 9). Amino acids 94-97 of 66268 encode a nuclear localization signal pattern 4 ([KR][KR][KR][KR]). The protein is described to be located in the nucleus. Moreover, a PEST-rich region (aa 108-126), a tyrosine phosphorylation site (aa 33) and a domain containing four tandem ankyrin-like repeats (aa 152-183) have also been found.

10

Fig. 10 d shows a schematic alignment of the cDNA fragments identified in SSH and FDD, respectively with their homologous Genbank entry and the open reading frame of 319 amino acids (aa). Not to scale. Homology scores were determined using blast2 algorithm of NCBI:

15

66268-X83703: Expect =  $9e-77$ , Identities = 152/152 (100%), Positives = 152/152 (100%)

52474-X83703: Expect =  $6e-23$ , Identities = 59/59 (100%), Positives = 59/59 (100%)

20

S1MC01-1-X83703: Expect =  $e-115$ , Identities = 227/234 (97%), Positives = 227/234 (97%).

Fig. 10 e shows RNA samples prepared from three control, four DCM, three ICM and one HCM heart tissue have been compared by fluorescence differential display using the primer combination [T7]T12MC and [M13r]ARP1 (with the arbitrary sequence CGACTCCAAG). The relative expression was calculated using ImageQuant Software and the lowest value set to 1 as reference for all values. Mean values and standard deviations were calculated from all NF and DCM samples, as well as from ICM75 and ICM96.

25

30

Fig. 10 f depicts the recombinant over expression of a 66268-YFP fusions protein in pCMs. The pCMs were transfected with an expression plasmid for a 66268-YFP fusions protein and stimulated with Phenylephrine (100  $\mu$ M). The YFP signal was detected with a fluorescence microscope (Axiovert 100S, Zeiss (Jena); YFP filter set, AF-Analysetechnik (Tübingen)) in combination with a digital camera (LAS-1000, Fuji; AIDA-software, Raytest).

## Examples

The following examples illustrate the invention. These examples should not be construed as limiting: the examples are included for purposes of illustration and the present invention is limited only by the claims.

### EXAMPLE 1

#### 1. Isolation of total RNA from heart tissue

Total RNA was isolated from tissue of explanted hearts of left ventricle of human non-failing and DCM patients, which are listed in TABLE 1, respectively, according to the protocol of Chomczynski and Sacchi with some minor modifications. 0.5 g tissue were disrupted using a mortar and pestle and grinded under liquid nitrogen. The suspension of tissue powder and liquid nitrogen was decanted into a cooled 50 ml polypropylene tube and nitrogen allowed to evaporate completely without thawing the sample. After addition of 10 ml solution D (4 M guanidinium thiocyanate, 25 mM sodium citrate pH 7.0, 0.5 % sodium-N-lauroyl-sarcosinat, 0.1 M 2-mercaptoethanol) the sample was homogenized immediately using a rotor-stator homogenizer (Ultra-Turrax T8, IKA Labortechnik) for 60 s at maximum speed. The sample was mixed with 1 ml 2 M NaOAc pH 4.0, 10 ml phenol (water saturated, pH 4.5-5) and 2 ml chloroform/isoamylalcohol (49/1). After incubation on ice for 15 min and centrifugation at 10000g for 30 min at 4 °C the aqueous phase was transferred to a fresh 50 ml polypropylene tube. RNA was precipitated with 1 vol isopropanol at -20 °C for at least one hour. After centrifugation at 10000g for 30 min at 4

°C the RNA pellet was redissolved in 5 ml Solution D and precipitated again with 1 vol isopropanol as described. The pellet was washed with cold 75% EtOH and dried at RT for 15 min. To completely dissolve RNA 500 µl DEPC-treated water were added and the sample was incubated at 60 °C for 10 min, final storage was at -80 °C. An aliquot was used  
5 for quantification by  $A_{260}$  measurement and separation on a formaldehyde agarose gel (Sambrook *et al.*) to check integrity and size distribution.

TABLE 1: Human heart samples

ID heart	ID library	diagnosis	sex	age	medication	explantation date
Normal controls						
GH1	NF9	cerebral hemorrhage	f	53	unknown	18.05.1995
GH2	NF19	unknown	m		unknown	
h92	NF1	(suspicion on hepatitis B)	f	50	unknown	20.07.1994
KN3	NF45	intracranial pressure at astrocytoma IV	f	41	Minirin, Dopamin, Rocephin, Dexamethason	30.08.1996
KN4	NF46	traumatic brain disease	m	33	Arterenol, KCl	08.06.1997
KN6	-	unknown			unknown	06.07.1997
KN7	-	unknown			unknown	02.01.1998
DCM samples						
h43	DCM6	DCM	f	54	Digitalis, diuretics, nitrates, ACEI	24.04.1990
h44	DCM13	DCM, Z.n. myocarditis	m	22	unknown	08.05.1990
h94	DCM15	DCM	m	16	Digitalis, ACEI, nitrate, catecholamines, diuretics	03.11.1994
h97	DCM14	DCM	m	62	Digitalis, diuretics, ACEI, Amiodaron, Marcumar	04.01.1995
h99	DCM49	DCM	m	64	Digitalis, diuretics, ACEI, Amiodaron, Marcumar, nitrate	17.05.1995
h100	-	DCM			unknown	20.09.1996
DHZM1	-	DCM	m	53	unknown	
ICM samples						
h75	-	ICM			unknown	05.10.1992
h79	-	ICM			unknown	20.04.1993
h80	ICM47	ICM			unknown	10.06.1993
h81	ICM48	ICM			unknown	17.06.1993
h96	-	ICM	m	39	Digitalis, ACEI, Amiodaron, Marcumar	13.12.1994
HCM samples						
h48	-	non-obstructive HCM	m	37	unknown	08.01.1991

## 2. Isolation of poly(A) RNA from total RNA

Poly(A) RNA was isolated from 300 µg total RNA (see 1.) using the PolyA Quick mRNA Isolation Kit (Stratagene) according to the manufacturers protocol. Purified mRNA was dissolved in 30 µl RNase-free water (Stratagene), quantified and analyzed on a formaldehyde agarose gel as described (see 1.).

## 3. Suppression subtractive hybridization (SSH)

### 3.1 Construction of a subtracted library

2 µg of tester mRNA and 2 µg of driver mRNA were used to construct a subtracted and normalized cDNA library using the PCR-Select cDNA Subtraction Kit and Advantage cDNA-Polymerase Mix (Clontech) according to the manufacturers protocol. In general, two libraries were constructed for each tester and driver combination, since only transcripts can be identified that are over-represented in the tester mRNA.

Both, the subtracted and non-subtracted cDNA population were analyzed on an agarose gel as described (Clontech) and transferred onto Zeta-Probe GT nylon membrane (BioRad) by capillary forces (Sambrook *et al.*). The membrane was UV crosslinked in a Stratalinker 2400 (Stratagene).

To analyze the subtraction efficiency the membrane was hybridized with a Digoxigenin-labeled probe synthesized from a housekeeping gene using the Dig-DNA Labeling and Detection Kit (Roche). For probe synthesis a 451 bp fragment of human GAPDH was amplified from 0.5-1 µg cDNA of a NF heart library (see 5.1.) in a 100 µl PCR reaction with the primer pair provided by the PCR-Select cDNA Subtraction Kit (Clontech). 100 ng of gel purified (QIAquick Gel Extraction Kit, Qiagen) GAPDH cDNA fragment then were used for Dig-labeling. The hybridized membrane was exposed to a X-ray film (X OMAT AR, Kodak) for 15 min. Only subtractions, where the GAPDH signal intensity of the subtracted cDNA population was at least four fold lowered compared to the corresponding non-subtracted cDNA-population, were selected for further analysis. 17 µl of the subtracted sample were purified using a PCR Purification Kit (Qiagen) and eluted in 20 µl ddH<sub>2</sub>O (Gibco BRL).

For addition of 3'-A overhangs 15.7 µl of the purified subtracted cDNA sample was incubated in the presence of PCR buffer, 1.5 U Taq DNA polymerase (APB) and 0.2 mM

dATP for 11 min at 72 °C. 3 µl of the sample was ligated into the pGEM-T easy vector (Promega) and competent *E. coli* cells were transformed as described by the manufacturer.

### 3.2 Amplification of subtracted cDNA clones

Subtracted cDNA clones were grown over night at 37 °C in 96 well microplates filled with  
5 100 µl LB medium (Sambrook *et al.*) and supplemented with 10 µg/ml Amp. 1 µl of the bacterial culture then was transferred into 99 µl PCR premix (1x PCR buffer, 2.5 U Taq DNA polymerase (APB), 0.2 mM dNTP) and directly amplified using the nested primer pair 1 and 2R provided by the PCR-Select cDNA Subtraction Kit (Clontech). Best results were obtained with 27 cycles and an annealing and polymerization temperature of 68 °C.  
10 The size distribution of PCR-products was analyzed on an 1% agarose gel (Sambrook *et al.*). Bacterial cultures were mixed with glycerol to a final concentration of 20% and stored at -80 °C.

## 4. Fluorescence differential display (FDD)

### 4.1 DNaseI digestion

Total RNA (see 1.) was digested using the MessageClean-Kit (GeneHunter) according to the manufacturers protocol.

### 4.2 Reverse transcription

Four degenerated primer pools [T7]-T<sub>12</sub>MA, [T7]-T<sub>12</sub>MC, [T7]-T<sub>12</sub>MG and [T7]-T<sub>12</sub>MT  
20 anchoring to poly(A) tails of mRNAs were used, where M is the degenerated position (a mixture of A, C, G). A 17 nt T7 RNA polymerase promoter-derived site (ACGACTCACTATAGGGC) is incorporated which allows the generation of an antisense transcript. For each RNA sample four separate reactions were performed.

200 ng of DNA-free RNA (see 4.1.) was denatured for 5 min at 70 °C in the presence of 0.2  
25 µM anchor primer [T7]-T<sub>12</sub>MX and 20 U rRNasin (Promega). After addition of RT buffer (Gibco), 10 mM DTT, 25 µM dNTP and 200 U SuperscriptII RTaseII (Gibco) on ice, the reaction with a final volume of 20 µl was performed for 5 min at 42 °C and 1 h at 50 °C. The reaction was stopped by heating 15 min at 70 °C.

### 4.3 PCR

Resulting cDNAs (see 4.2.) were reamplified in the presence of the same anchor primer labeled with Cy5 and a second primer with 10 nt of arbitrary chosen sequence. A 16 nt segment of the M13 universal reverse (-48) 24mer priming sequence (ACAATTTACACAGCA) is incorporated in the arbitrary primer [M13r]-ARPX<sub>10</sub> for direct sequencing.

1 µl of reverse transcription sample (see 4.2.) was mixed on ice with 1x PCR buffer (Qiagen), 3.75 mM MgCl<sub>2</sub>, 0.35 µM Cy5-[T7]-T<sub>12</sub>MX, 0.35 µM [M13r]-ARPX<sub>10</sub>, 50 µM dNTP and 0.5 U Taq polymerase (Qiagen) in a final volume of 20 µl. PCR was run in a Peltier Thermal Cycler PTC 200 (MJ Research) under the following conditions: 2 min 95 °C, [15 s 92 °C, 30 s 50 °C, 2 min 72 °C]<sub>4</sub>, [15 s 92 °C, 30 s 60 °C, 2 min 72 °C]<sub>25</sub>, 7 min 72 °C, 4 °C.

### 4.4 Electrophoresis on a 6% denaturing polyacrylamide gel

The PCR sample (20 µl, see 4.3.) was mixed with 6 µl gel loading dye (95% formamide, 20 mM EDTA, 0.005% BPB), denatured for 2 min at 80 °C and separated on a standard sequencing gel (6% polyacrylamide/8.3 M urea) at 55 W for 3 h. The gel was dried on Whatman 3MM paper and fluorescence signals read at 635 nm on a Storm fluorimager (Molecular Dynamics). Data analysis was performed using ImageQuant Software (Molecular Dynamics) as described below (see 6.3.).

### 4.5 Recovery of PCR fragments from the sequencing gel

Individual bands of interest (see 4.4.) were cut out of the gel with a scalpel. The gel slice attached to Whatman paper was soaked for 1 h at 37 °C (300 rpm) in 100 µl buffer EB (Qiagen) and incubated at 4 °C over night. Supernatant was purified using the QIAquick PCR purification Kit (Qiagen) as described by the manufacturer. DNA was eluted into 30 µl EB buffer (Qiagen).

### 4.6 Reamplification of differential display PCR fragments

All PCR fragments recovered from the differential display gel could be reamplified with a set of universal primers, M13r(-48) primer [AGCGGATAACAATTTACACAGGA] and T7 primer [GTAATACGACTCACTATAGGGC]. A 40 µl PCR was set up on ice with 3 µl template (see 4.5.), 1x PCR buffer, 1.5 mM MgCl<sub>2</sub>, 20 µM dNTP, 0.2 µM T7 primer, 0.2

$\mu$ M M13r(-48) primer and 2 U Taq polymerase (Qiagen) and run as described above (see 4.3.).

#### 4.7 Electrophoresis on a preparative 1.2% agarose gel

30  $\mu$ l of reamplified PCR sample were mixed with 6  $\mu$ l loading dye and separated on an  
5 1.2% agarose/1x TBE gel together with a size standard and a PCR marker (Promega). Bands were cut out with a scalpel and DNA extracted from agarose gel slice using QIAquick gel extraction Kit as described (Qiagen). 1  $\mu$ l of recovered DNA was used for sequencing.

### 10 5. Preparation of cDNA libraries and probe synthesis

Since the availability of heart material is very limiting, labeled *in vitro* transcripts of a cDNA library prepared from heart mRNA were used for dot blot hybridization instead of reverse transcribed mRNA itself.

#### 5.1 Preparation of a cDNA library

15 5  $\mu$ g of high quality mRNA (see 1., see 2.) were used to prepare a cDNA library using the cDNA Synthesis Kit and ZAP-cDNA Gigapack III Gold Cloning Kit (Stratagene) as described in the manual with the following modifications:

- (a) Packaging and titering: 2.5  $\mu$ l of the ligation reaction were packaged. If the library did not represent at least one million clones, the remaining 2.5  $\mu$ l were also packaged.  
20 After centrifugation of XL1-Blue MRF' culture (50 ml), the cells were gently resuspended in 10 mM MgSO<sub>4</sub> at 4 °C and immediately used for transduction or stored for max 40 h at 4 °C.
- (b) Determination of the insert size: 25 plaques were transferred from agar plates used for titering directly into 40  $\mu$ l PCR premix (1x PCR-buffer, 0.25  $\mu$ M T3 primer, 0.25  
25  $\mu$ M T7 primer, 200  $\mu$ M dNTP, 0.085 U Taq DNA-polymerase) and inserts amplified using 35 cycles and an annealing temperature of 48 °C. The insert size was checked on an agarose gel and was in the range of 1-2 kb.
- (c) Storage of the library: Libraries were transferred into 50 ml-polypropylene tubes, supplemented with 150  $\mu$ l 0.3 % chloroform and stored at 4 °C. A part of each library  
30 was stored in 7 % DMSO at -80 °C.

Mass *in vivo*-excision was done according to the protocol of the ZAP-cDNA Gigapack III Gold Cloning Kit with the following modifications:

Transfected XL1 Blue MRF' were grown in 25 ml LB. 5 ml of the supernatant containing single stranded phages was used to infect 20 ml of SOLR cells. Remaining 20 ml of single  
5 stranded phages were stored at 4 °C for up to two months. To determine the titer of excised phagemids 10 µl, 1 µl and 0.1 µl of infected SOLR cells were plated on LB/Amp dishes. If the titer was lower than one million, 5 ml or more of the remaining supernatant was used again to infect fresh SOLR cells. Infected SOLR cells (25 ml) were grown in 200 ml LB/Amp over night for plasmid isolation (Plasmid Midi Kit, Qiagen).

### 10 **5.2 Linearization of the template cDNA library for *in vitro* transcription**

200 µg plasmid DNA were digested with XhoI over night at 37 °C in a volume of 250 µl to linearize the plasmid at the 3' end of the insert. The sample was controlled for complete digestion on an agarose gel, treated with 10 µg/µl Proteinase K (Roche) at 37 °C for 30 min, extracted once with TE saturated phenol (pH 7.5-8) and once with  
15 chloroform/isoamylalcohol (24/1) and precipitated in the presence of 0.1 volume 3 M NaOAc (pH 5.2) and 3 volume EtOH. The pellet was washed with 500 µl 75% ethanol, dried at RT for 10 min, dissolved in 150 µl DEPC-treated water and quantified.

1 µg of linearized plasmid was used for an *in vitro* transcription as described (see 5.3.), omitting the radioactive labeled nucleotide and adding UTP to a final concentration of 10  
20 mM. Following DNaseI digestion, the RNA was extracted with phenol/chloroform/isoamylalcohol (24/23/1), precipitated with EtOH and dissolved in 15 µl DEPC-treated water. The yield was in the range of 15-22 µg RNA. 1.5 µl RNA were separated on a formaldehyde agarose gel. A smear of transcripts was visible between 0.5 kb and 10 kb with a peak at about 1 kb.

### 25 **5.3 *In vitro* transcription**

According to the RNA Transcription Kit (Stratagene) 1 µg of linearized template (see 5.2.) was incubated in the presence of 1x transcription buffer, 10 mM ATP, 10 mM CTP, 10 mM GTP, 1 mM UTP, 70 µCi [ $\alpha$ -<sup>33</sup>P]UTP (APB), 0.75 M DTT, 20 U rRNasin (Promega) and  
25 U T3 RNA polymerase for 30 min at 37 °C. After addition of 5 U RNase-free DNaseI  
30 (Roche) the sample was incubated for 15 min at 37 °C. 25 µl STE-buffer (APB) was added

to the probe and the reaction purified using G50 Micro Columns (APB) according to the manufacturers protocol.

#### 5.4 Prehybridization of *in vitro* transcripts

To suppress probe hybridization to human repetitive DNA, labeled RNA was prehybridized  
5 to cot1-DNA. 213  $\mu$ l DEPC-treated water, 100  $\mu$ l 20x SSC, 2  $\mu$ l 20% SDS and 40  $\mu$ l cot1-DNA (1  $\mu$ g/ $\mu$ l, Gibco BRL) were added to 45  $\mu$ l labeled RNA (see 5.3.), denatured at 95 °C for 2 min and incubated for 2 h at 65 °C.

### 6 Quantitative Dot Blot Analysis

#### 10 6.1 Transfer of PCR fragments onto nylon membrane

For spotting, approximately 300 ng PCR product (see 3.2.) or gene-specific control cDNA fragments were mixed with 140  $\mu$ l 0.4 M NaOH/10 mM EDTA pH 8.0 in 96 well microplates and denatured 10 min at 95 °C. 50  $\mu$ l of each PCR-fragment (at least 100 ng cDNA) were transferred on a nylon membrane (11.4x7.5 cm, BioRad) using a 384 hole  
15 vacuum apparatus (Keutz, custom-made). 50  $\mu$ l 0.4 M NaOH were added to each position and transferred. The membrane was washed in 2x SSC, dried for at least 1 h at RT and fixed by UV crosslinking (Stratalinker 2400, Stratagene). For each experiment two identical membranes were prepared in parallel.

#### 6.2 Dot blot hybridization and washing

20 The cDNA filter was soaked in 2x SSC and transferred into a hybridization flask. The membrane was hybridized with 10 ml hybridization solution (6x SSC, 5x Denhardts, 0.2 % SDS, 0.2 % sodium pyrophosphate) supplemented with 50  $\mu$ g/ml denatured salmon sperm DNA (Typ III, Sigma) at 65 °C for 2 h in an Unitherm 6/12 hybridization oven (UniEquip). The prehybridization mix was poured off. 200-400  $\mu$ l of cot1-hybridized probe (see 5.4.)  
25 were added to 8 ml of hybridization solution (including salmon sperm DNA) preheated to 65 °C. Dot blots were hybridized over night at 65 °C. For washing of cDNA filters all solutions were heated to 65 °C. The membrane was washed twice with 50 ml wash solution 1 (2x SSC, 0.1 % SDS) for 30 min, then twice with 50 ml wash solution 2 (0.1x SSC, 0.1 % SDS) for 30 min and wrapped in a keep-fresh foil. The filter was exposed to a phosphor

screen for two days and scanned at 450 nm using the Storm Phosphoimager (Molecular Dynamics).

### 6.3 Data analysis

Signal intensities were calculated using ImageQuant Software (Molecular Dynamics) by  
5 subtracting the local background. For comparison of different filters signal intensities were  
normalized by adjusting the overall intensity of each filter to 100%. In general, two cDNA  
filters were hybridized successively with 10 probes prepared from different human heart  
samples.

Dots which represented at least two fold changes in signal intensity comparing the group of  
10 DCM heart samples (y) with that of normal controls (x) were selected for further analysis.  
The probability of type 1 error was calculated to be less than 5% using the Wilcoxon test.  
This non-parametric statistic algorithm does not assume any distribution of x and y values.  
If the sample size of one group was smaller than 4 the Wilcoxon test could not be applied.  
Instead significance of gene regulation was confirmed by a t-test. The t-test assumes that  
15 standard deviations of both groups x and y are similar and values distributed according to  
normal distribution.

Independent of the disease individual differences between human samples are expected.  
They are the result of the different genetic background of individuals, sex, age,  
environmental and life conditions (e.g. smoking, drinking, nourishment), the status of  
20 disease and medical treatment. Especially DCM patients were treated by a number of drugs  
prior to heart transplantation. We laid down that the regulation has to be consistent in at  
least two DCM patients and more or less homogenous in all but one non-failing patient.

Selected clones were grown in 5 ml LB/Amp from glycerol stocks (see 3.2.). Plasmids were  
isolated using the Plasmid Mini Kit (Qiagen) and sequenced.

### 25 6.4 Stripping of dot blot membranes

cDNA filters were transferred into boiling stripping solution (0.1x SSC, 0.5 % SDS) and  
incubated for 1 h at RT. This procedure was repeated until no more radioactivity could be  
detected by a Geiger-Müller counter. The filter again was wrapped in keep-fresh foil and  
stored at RT.

## 7. Full-length cloning:

Full-length cloning was performed using RT-PCR with oligonucleotides priming to the 5'- and 3'- ends of the sequence encoding the open reading frame. PCR-fragments were then purified by agarose gel-electrophoresis followed by gel elution using the gel purification kit from Qiagen. PCR-fragments were finally cloned into p201-DONOR (Life Technologies) or pTOPO2.1 (Invitrogen).

The cloned cDNAs were verified by sequencing. In addition, *in vitro* translations were performed using the TNT Quick Coupled Transcription/Translation Systems (Promega) in order to verify the correct molecular weight of the proteins encoded by a given cDNA. The full-length clones were named according to their ID number provided with the suffix "-cgs" (xxxxx-cgs). The proteins were named according to their ID number provided with the suffix "-pep" (xxxxx-pep).

## 8. Yeast two-hybrid system

### 8.1 Two-hybrid screen protocol (Golemis et al., 1994).

The yeast two-hybrid vectors are described in section below. Yeast strains used were EGY48LacZ-GFP (*ura3::6\*LexOp-lacZ*, *lys2::6\*LexOpCYC1GFP*, *his3*, *trp1*, *6\*LexAOp-LEU2*, *mat $\alpha$* ) and EGY199UL (*ura3::6\*LexOp-lacZ*, *his3*, *trp1*, *6\*LexAOp-LEU2*, *mat a*). Yeast was grown in YPD or selective minimal medium (Sherman 1986). Transformations were done using the high-efficiency method of Gietz et al., 1992. The bait plasmids were first introduced in the yeast strain EGY48LacZ-GFP resulting in the strain EGY48LacZ-GFP-bait. Self activation of the bait was checked by plating the yeast on minimal glucose medium with or without X-Gal (5-bromo-4-chloro-3-indolyl- $\beta$ -D-galactopyranoside). In parallel protein expression was verified by western blot analysis using a polyclonal rabbit anti-LexA antiserum. A human heart cDNA library (pJG#19) cloned (EcoRI/XhoI) in the vector pJG4-5 was then introduced in the EGY48LacZ-GFP-bait strain. After transformation  $4 \times 10^4$  colonies per plate) yeast were plated on selective medium (-histidine, -tryptophane, +methionine, glucose). Colonies were harvested and an aliquot was plated on selective medium (-histidine, -tryptophane, -uracil, raffinose, galactose, X-gal). The interactions were assayed by colony growth on selective medium as

well as by  $\beta$ -galactosidase activity on the plate. Positive clones were plated over night on medium (-histidine, -tryptophane, -uracil, glucose, X-gal) in order to deactivate the expression of the prey. The verification of the interaction was performed by plating the colonies on medium A:(-histidine, -tryptophane, -uracil, glucose, X-gal) and medium B:  
5 (-histidine, -tryptophane, -uracil, raffinose, galactose, X-gal). Only blue colonies growing on medium B but not on medium A were further analysed by yeast-colony-PCR. Plasmids were rescued and introduced in *E.coli* (Robzyk and Kassir , 1992). DNA was isolated from the bacteria and sequenced. Interactions were finally verified by reintroducing the plasmid (prey) in the yeast strain EGY199UL. Mating of the EGY199UL (prey) with the  
10 corresponding EGY48LacZ-GFP (bait) was performed in order to get a diploid strain carrying bait and prey (Guthrie and Fink,1991; Pringle et al., 1997; Golemis and Khazak, 1997) . Protein interaction resulted in growth and blue colour of the diploid colonies on medium B but not on medium A. Interactions were further analysed by quantifying the relative activity of the GFP reporter in a FACS assay.

## 15 8.2 Two hybrid vectors description

### 8.2.1 Bait vectors

- 1) pSH2-1 (Hanes SD. and Brent R. 1989)
- 2) pEG202(U8996)
- 3) 413MetLexN0

20 The vector 413MetLexN0 was constructed by cloning a PCR generated full length LexA repressor cDNA (with XbaI/BamHI overhangs) into the vector 413Met25 (Mumberg et al., 1994) cut XbaI/BamHI.

- 4) 413MetLexN0.att

The destination vector 413MetLexN0.att was constructed by introducing the rfC cassette of  
25 the Gateway™ system (Invitrogen) into the vector 413MetLexN0. For this purpose a linear PCR fragment comprising the rfC-cassette and flanking homologies of 40 bp to the LexA gene or 40 bp(5-prime) of the CYC1 terminator(3-prime) of the vector 413MetLexN0 was used for homologous recombination to the EcoRI linearized vector 413MetLexN0 in yeast. One correct recombinant vectors was re isolated from yeast and can be used for cloning of  
30 cDNAs by in vitro recombination performing a LR-reaction of the Gateway™ system.

## 5) 413MetLexC0

The vector 413MetLexC0 was constructed by cloning a PCR generated full length LexA repressor cDNA (with HindIII-ClaI-XhoI/SalI overhangs) into the vector 413Met25 (Mumberg D et al., 1994) cut HindIII/XhoI.

## 5 6) 413MetLexC0.att

The destination vector 413MetLexC0.att was constructed analogous to the procedure described for the vector 413MetLexCN.att.

**8.2.2 Prey vectors**

## 1) pJG4-5(U89961)

## 10 2) 424GBN0

The vector 424GBN0 was constructed by cloning a PCR generated full length B42 transactivation domain cDNA (with XbaI/BamHI overhangs) derived from the vector pJG4-5 into the vector 424GAL1(Mumberg D et al., 1994) cut SpeI/BamHI.

## 3) 424GBN0.att

15 The destination vector 424GBN0.att was constructed by introducing the rfC cassette of the Gateway™ system (Invitrogen) into the vector 424GBN0. For this purpose a linear PCR fragment comprising the rfC-cassette and flanking homologies of 40 bp to the LexA gene or 40 bp(5-prime) of the CYC1 terminator(3-prime) of the vector 424GBN0 was used for homologous recombination to the EcoRI linearized vector 424GBN0 in yeast. One correct  
20 recombinant vector was re-isolated from yeast and can be used for cloning of cDNAs by in vitro recombination performing a LR-reaction of the Gateway™ system.

## 4) 424GBC0

The vector 424GBC0 was constructed by cloning a PCR generated full length B42 transactivation domain cDNA (with HindIII-ClaI-XhoI/SalI overhangs) into the vector  
25 424GAL1 (Mumberg D et al., 1994) cut HindIII/XhoI.

## 5) 424GBC0.att

The destination vector 424GBC0.att was constructed analogous to the procedure described for the vector 424GBCN.att.

**8.3 Two-hybrid interaction matrix (40K matrix)**

30 A collection of yeast two-hybrid 200 plasmids (baits and preys) made at Medigene was introduced in EGY48LacZ-GFP and EGY199UL respectively. Each EGY48LacZ-GFP-bait

were challenged against each EGY199UL-prey for interaction via mating (Golemis and Khazak, 1997). The resulting interactions tested were  $40 \cdot 10^3$ . This procedure correspond to the MediGene 40K matrix. Positive interaction were scored by growth on selective medium and  $\beta$ -galactosidase activity. Moreover, the strength of the interactions were quantified in a FACS assay. All interactions were stored in the programme CACI (Computer analysis of Complex Interactions). Matrix interaction analysis was performed using the programme CACI.

## 9. Recombinant gene expression in cardiomyocytes

### 9.1 Isolation of primary cardiomyocytes from neonatal rats

Neonatal rats (P2-P7) were sacrificed by cervical dislocation. The ventricles of the beating hearts were removed and cardiomyocytes were isolated with the "Neonatal Cardiomyocyte Isolation System" (Worthington Biochemicals Corporation, Lakewood , New Jersey) according to the protocol. Briefly, the ventricles were washed twice with ice cold Hank's Balanced Salt Solution without Potassium and Magnesium (CMF-HBBS) and minced with a scalpel to an average volume of one cubic millimeter . The heart tissue was further digested over night with trypsin at 10°C. Next morning trypsin inhibitor and collagenase were added. After an incubation at 37°C and mild agitation for 45 minutes the cells were dispersed by pipetting. The solution was further purified by 70  $\mu$ m mesh (Cell Strainer) and centrifuged twice for 5 minutes at 60 x g. The cell pellet was resuspended in plating medium and counted. Cells were seeded with a density of  $2 \times 10^4/\text{cm}^2$  on gelatine (Sigma, Deisenhofen) coated dishes. The next morning cells were washed twice with DMEM and maintenance medium was added.

Plating medium: DMEM/M-199 (4/1); 10% Horse serum, 5% Fetal calf serum;  
1 mM sodiumpyruvate; antibiotics and antimycotics  
Maintenance medium: DMEM/M-199 (4/1); 1 mM sodiumpyruvate

### 9.2 Construction of expression plasmids for cardiomyocytes

The pCI-vector (Promega) was cut with BsrGI. The linearized vector was incubated with the Klenow-fragment and dNTPs to generate blunt ends. The resulting vector was cut with

NheI and NotI after religation and gel purified. A PCR fragment comprising the entire open reading frame without the start codon of the yellow variant of the green fluorescent protein (YFP) was inserted into the NheI and NotI sites. The PCR was performed under standard conditions with the following primers to add several unique restriction site for further cloning:

5'-primer: SpeI-XbaI-EcoRI-XhoI-YFP

5'-GGA CTA GTT CTA GAG AAT TCC TCG AGG TGA GCA AGG  
GCG AGG AG-3'

3'-primer: YFP-STOP-NotI (the NotI site was derived from the vector)

5'-AGT TGG TAA TGG TAG CGA CC-3'

template: pEYFP-vector (Clontech)

The PCR product was gel purified and digested with SpeI and NotI the generate compatible ends. The resulting vector was linearized with XbaI and EcoRI and gel purified in order to insert a consensus Kozak-sequence, which was derived from oligo annealing.

5'-Kozak: 5'-CTA GAA CTA GTT CCA CCA TGG-3'

3'-Kozak 5'-AAT TCC ATG GTG GAA CTA GTT-3'

In the final construction step the plasmid was linearized with EcoRI and XhoI and gel purified. A PCR fragment comprising the entire open reading frame of 66268 flanked by an EcoRI site at the 5'-end and a XhoI site at the 3'-end was inserted.

### 9.3 Stimulation of isolated cardiomyocytes from neonatal rats

Stimulation of primary cardiomyocytes from neonatal rats (pCMs) was started two to six hours after medium was changed to maintenance medium. Directly after stimulation pCMs were infected with recombinant adenoviruses at a MOI of five. Cells were incubated for 48 hours at humidified atmosphere at 37°C and 5% CO<sub>2</sub> followed by an analysis of morphological alterations.

### 9.4 Transient transfection of isolated cardiomyocytes from neonatal rats

For each well of a six well plate 1 µg of plasmid DNA was combined with 20 µl 2 x BBS and 100 µl maintenance medium without antibiotics. Meanwhile 4 µl of LIPOFECTAMINE (Gibco/BRL) were mixed with 650 µl maintenance medium without antibiotics in a polystyrene tube. The DNA-sample was added after an incubation for 15' at room-temperature. The suspension was mix by inverting the tube twice and incubated for

15' at room-temperature. Meanwhile medium was changed to 1 ml maintenance medium without antibiotics. The transfection-mixture was added onto the cells and gene expression was analysed 48 hrs later.

2 x BBS:                    50 mM BES  
5                                280 mM NaCl  
                                  1.5 mM Na<sub>2</sub>HPO<sub>4</sub>  
                                  adjust to pH 6.95 by administration of NaOH

## EXAMPLE 2

10 EST 40399 (FIG. 1A) was identified by suppression subtractive hybridization comparing transcript levels of heart tissue explanted from normal control h92 with one from DCM patient h97 (see TABLE 1). The fragment was found to be over-represented in the DCM tissue.

15 As of FIG. 1 D the identified cDNA fragment is a part of the EST clone NM\_003970 (FIG. 1 B), which encodes the amino acid sequence NP\_003961 (identical to CAA48832; FIG. 1 C). This amino acid sequence encodes the 165 kDa M-protein, also known as myomesin 2 or MYOM2.

20 Z and M bands of the sarcomere are interconnected by the long titin molecules. The 165 kDa M-protein is one of two known titin-associated proteins, which seem responsible for the formation of a head structure on one end of the 0.9 micron long titin string (Vinkemeier *et al.*). M-protein may function in strengthening the links between thick filaments necessary to withstand the stronger tension during contraction in the heart and in fast fibers (van der Ven *et al.*)

25 Upregulation upon DCM was confirmed for two additional DCM patients compared to five normal control hearts by quantitative dot blot analysis (FIG. 1 E). The relative expression level of 40399 is induced by a factor of 3.1 upon disease. The probability of type 1 error is less than 5% as determined in a t-test.

30 Expression was not induced in two DCM patients, which may reflect individual differences throughout the population.

Significant upregulation of 40399 expression in heart tissue of two DCM patients compared to five normal controls indicates that an increased expression of 40399 is associated with dilated cardiomyopathy. Upregulation of titin-associated muscle M-protein by a factor of 3 may massively interfere with normal myofibril assembly and stabilization and decrease muscular activity. From our data we conclude that abnormalities in expression of this protein are associated with muscular abnormalities that result in cardiomyopathies. Therefore we expect the protein to play a causative role in heart diseases, especially congestive heart failure.

Mutations in other sarcomeric proteins have already been identified as causes of hypertrophic cardiomyopathy, suggesting that cytoskeletal proteins play a central role in cardiac function (Hein *et al.*). These findings support our general observation of a causative correlation between deregulation of sarcomeric proteins and reduced contractile function in end-stage heart failure. Therefore, 40399 can serve as a heart disease marker and a specific molecular target for drug development.

Downregulation of protein expression by specific inhibitors or antisense constructs seems to be a very promising therapeutic tool to treat heart diseases.

### EXAMPLE 3

EST 41441 (FIG. 2 A) was identified by suppression subtractive hybridization comparing transcript levels of heart tissue explanted from normal control h92 with one from DCM patient h97 (see TABLE 1). The fragment was found to be over-represented in the control tissue. The identified cDNA fragment is a part of the EST clone AW755252 (FIG. 2 B), which predicts an amino acid sequence 41441pep given in FIG. 2 C (schematic alignment FIG. 2 D).

Downregulation upon DCM was confirmed for four DCM patients compared to five normal control hearts by quantitative dot blot analysis. The relative expression level of 41441 is reduced by a factor of 4.5 upon disease (FIG. 2 E). The probability of type 1 error is less than 5% as determined in a Wilcoxon test.

The EST clone AW755252 (Walker *et al.*) was isolated from a human cardiac muscle expression library and found to be similar to cardiomyopathy associated gene 3 (CMYA3, unpublished).

The LIM sequence motif is a part of the cardiomyopathy associated gene 3.

5 The LIM sequence motif was first identified in homeodomain proteins Lin-11, Isl-1 and Mec-3. The LIM domain is a double zinc finger motif that mediates the protein-protein interactions of transcription factors, signaling- and cytoskeleton-associated proteins. There is no evidence, that LIM domains bind DNA directly. Instead, an increasing number of studies implicate LIM domains in protein-protein interactions that regulate development,  
10 cellular differentiation and the cytoskeleton (Bach).

#### **Yeast two-hybrid interactions**

Interactors with the protein coded by 41441pep were screened using 41441pep as a bait. A large screen was performed using 4 large plates for the library transformation which led to  
15 the analysis of  $2 \times 10^7$  clones. The two hybrid procedure described (protocol 22) led to the identification of 4 different interacting partners. The corresponding cDNAs were identified by homology search using the first 500 nucleotides sequence of the pray clone. The partners are: Hepatitis B virus interacting protein (AF029890), U6 snRNA-associated Sm-like protein LSm8 (AF182294), unknown protein HSPC297 (AF161415) and supervillin  
20 (AF051851).

#### Hepatitis B virus interacting protein or XIP

The identity with Hepatitis B virus interacting protein (AF029890) was found to be 100% over the first 400 amino acids. The homology starts at nucleotide 9 of the AF029890  
25 sequence. The XIP cDNA recognizes a single 0.7 kb transcript in all tissues studied and was particularly abundant in skeletal and cardiac muscles tissues (Melegari *et al.*, 1998). The XIP protein was also found to interact with the hepatitis B virus protein HBx (Melegari *et al.*, 1998). Interestingly, over-expression of the XIP protein prevented wild-type HBx activity on such promoters as well as reduced HBV replication to levels comparable to  
30 those observed with an HBx-minus variant strain (Klein *et al.*, 1999 )

### U6 snRNA-associated Sm-like protein LSm8

The sequence revealed 100% homology to Homo sapiens U6 snRNA-associated Sm-like protein LSm8 over 400 nucleotides. The homology starts at nucleotide 31 of the AF182294 sequence. The yeast homologue of Lsm8 seems to be play a role, together with Lhp1, as a molecular chaperone of polymerase III. Lsm8 might be implicated in the very early steps of the U6 snRNP assembly (Panome et al., 1998).

### Supervillin

Homology search using the interactor of clone 41441 led to the identification of supervillin (SVIL) (XM\_011894, AF109135) with 99% identity. Supervillin RNA are expressed ubiquitiously. The human supervillin gene is localized to a single chromosomal locus at 10p11.2 a region that is deleted in some prostate tumours as well as in so tumour cell lines (Pope et al., 1998). The cDNA sequence of this interactor showed identity to supervillin isoform 2, a membrane associated F-actin binding protein. This protein is also known as archvillin or p205. The identity starts at amino acid 1872 and stops at 1997. Alignment with clones of the database showed that the bait encodes the C-terminal part of the protein supervillin. In this sequence the motif GEL (Gelsolin homology domain) could be identified from amino acid 39 to 138. This domain was also found in Gelsolin/severin/villin. It is thought to exist both as a intra- and extracellular domain and and may be responsible for Calcium-binding as well as actin-binding. This protein is tightly associated with both actin filaments and plasma membrane specifically in focal adhesion plaques. Over-expression of full-length supervillin in these cells disrupts the integrity of focal adhesion plaques and results in increased levels of F-actin and vinculin. Moreover, supervillin contains nuclear targeting signals in the centre of the protein which seem to be functional. Therefore supervillin may contribute to cytoarchitecture in the nucleus as well as at the plasma membrane (Wulfkuhle et al., 1999).

Significant downregulation of 41441 expression in heart tissue of four DCM patients compared to five normal controls indicates that a lowered expression of 41441 is associated with dilated cardiomyopathy. Lowered expression of 41441 by a factor of 4-5 seems to

induce a cardiomyopathic phenotype. Therefore we expect the protein to play a causative role in heart diseases, especially congestive heart failure.

The predicted functional domain LIM\_1 also indicates a major role of 41441 in regulation of development, cellular differentiation or the cytoskeleton. From our data together with those from Genbank entree AW755252 we conclude that 41441 is predominantly expressed in cardiac muscle, which supports our idea that 41441 can serve as a marker for heart diseases and a specific molecular target for drug development.

Upregulation of protein expression by gene therapeutic intervention, compensatory molecules or specific activators seems to be a very promising therapeutic tool to treat heart diseases.

#### EXAMPLE 4

EST 52706 (FIG. 3 A) was identified by suppression subtractive hybridization comparing transcript levels of heart tissue explanted from normal control KN2 with one from DCM patient DHZM3 (see TABLE 1). The fragment was found to be over-represented in the diseased tissue.

EST 52706 (FIG. 3 A) was found to be repressed upon disease in screens for expression profiles using suppression subtractive hybridization (?). Transcript levels are significantly downregulated by a factor 27,3 in five DCM patients compared to five normal controls (FIG. 3 B). The probability of type 1 error is less than 5% as determined in a Wilcoxon test. Significant homologies to known sequences from Genbank were not found.

Significant downregulation of 52706 expression in heart tissue of six DCM patients compared to the same number of normal controls indicates that a lowered expression of 52706 is associated with dilated cardiomyopathy. The extreme decrease in expression of 52706 by a factor of 27 seems to induce a cardiomyopathic phenotype. Therefore we expect the protein to play a causative role in heart diseases, especially congestive heart failure. As a conclusion 52706 can serve as a marker for heart diseases and a specific molecular target for drug development.

Upregulation of protein expression by gene therapeutic intervention, compensatory molecules or specific activators may be a therapeutic tool to treat heart diseases.

#### EXAMPLE 5

5

EST 56461 (FIG. 4 A) was identified by suppression subtractive hybridization comparing transcript levels of heart tissue explanted from normal control KN5 with one from DCM patient h52 (see TABLE 1). The fragment was found to be over-represented in the DCM tissue.

10 The identified cDNA fragment was found to be overlapping with the EST clone AF077035 (FIG. 4 B), which encodes the amino acid sequence AAD27768 (FIG. 4 D). The predicted amino acid sequence for 56461 is shown in sequence 56461pep (FIG. 4 C).

AF077035 was isolated from CD34(+) hematopoietic stem and progenitor cells (HSPC, Zhou *et al.*). The amino acid sequence of AAD27768 is to 91% identical to one translated  
15 from EST AW785791, which was identified to be specifically expressed in pooled tissues from *Sus scrofa* embryos (Fahrenkrug *et al.*).

Upregulation upon DCM was confirmed for two additional DCM patients compared to five normal control hearts by quantitative dot blot analysis (FIG. 4 E). For these samples,  
20 DCM15 and DCM13, the relative expression level of 56461 is induced by a factor of 5,4. The probability of type 1 error is less than 1% as determined in a t-test.

The remaining three DCM patients did not show a significant change in 56461 expression, which may be the result of individual differences throughout the population.

25 Significant upregulation of 56461 expression in heart tissue of three DCM patients compared to six normal controls indicates that an increased expression of 56461 is associated with dilated cardiomyopathy. Increased expression of 56461 by a factor of 5-6 seems to induce a cardiomyopathic phenotype. Therefore we expect the protein to play a causative role in heart diseases, especially congestive heart failure.

Moreover, the homology to RNA binding domains may indicate a regulatory function for 56461. This finding supports our idea that 56461 can serve as a marker for heart diseases, especially congestive heart failure and a specific molecular target for drug development.

Downregulation of protein expression by specific inhibitors or antisense constructs seems to be a very promising therapeutic tool to treat heart diseases.

### EXAMPLE 6

EST 61105 (FIG. 5 A) was identified by suppression subtractive hybridization comparing transcript levels of heart tissue explanted from normal control KN4 with one from DCM patient h94 (see TABLE 1). The fragment was over-represented in the control tissue. The identified cDNA fragment was found to be a part of the EST clone M14780 (FIG. 5 B), which encodes the amino acid sequence AAA52025 (FIG. 5 C; schematic alignment FIG. 5 D). This amino acid sequence encodes the muscle isoform of creatine kinase (creatine kinase M, Perryman *et al.*), which is one of the important structural and energy metabolism components in skeletal muscle. It catalyzes the reversible transfer of phosphoryl group from creatine phosphate to ADP to form ATP to sustain contractile activity.

Downregulation upon DCM was confirmed for five DCM patients compared to the same number of normal control hearts by quantitative dot blot analysis (FIG. 5 E). The relative expression level of 61105 is significantly reduced by a factor of 4 upon disease. The probability of type 1 error is less than 5% as determined in a Wilcoxon test.

#### Yeast two-hybrid interaction

The interactors were identified using the 40K matrix of MediGene and analysed by MediGene CACI programme. The following three proteins interact with AAA52025: CapZa (P52907), c-Raf (P04049), FBP (AF049528).

### CapZ $\alpha$

CapZ  $\alpha$  has been localized on Chromosome 1 at position 1p36.13-q23.3. CapZ  $\alpha$  is an Actin capping protein which binds as heterodimer F-actin at the fast growing end in a Ca<sup>2+</sup>-independent manner.

5

### FBP11 (Formin binding protein):

Synonyms for FBP are: HYP A, huntingtin-interacting protein (AF049528, AF049524, AF049523) and Fas-ligand associated factor (U70667). FBP11 contains WW motifs that recognize PPXY or PPLP motifs to mediate the interaction (Bedford et al., 1997). Creatine-kinase-M contains a PPXY motif at position 143.

10

### c-Raf (isoforme of Raf-1)

c-Raf was localized on chromosome 3 at locus 3p25. This protein belongs to the Ser/Thr family of protein kinase, it contains a zinc-dependent phospholipase C and DAG binding domain. Moreover, a relationship between c-Raf and Creatine kinase has been shown by other groups in myoblasts (Coolican et al., 1997; Samuel, 1999) and in rhabdomyosarcoma (Ramp et al., 1992).

15

Significant downregulation of 61105 expression in heart tissue of five DCM patients compared to the same number of normal controls indicates that a lowered expression of 61105 is associated with dilated cardiomyopathy. Downregulation of creatine kinase M by a factor of 4 massively decreases the energy reservoir which is necessary to sustain muscle contractility. Therefore we expect the protein to play a causative role in heart diseases, especially congestive heart failure.

25

The protein expression was also observed to be deregulated upon canine rapid ventricular pacing, which produces a low output cardiomyopathic state similar to DCM (Heinke *et al.*). Taken together, these results strongly support the notion that energy production is impaired and mitochondrial dysfunction is involved in the development of heart failure. These findings support our general observation of a causative correlation between energy

30

depletion and end-stage heart failure. Therefore, 61105 is a marker and in our opinion also a specific molecular target for drug development.

Upregulation of protein expression by gene therapeutic intervention, compensatory molecules or specific activators seems to be a very promising therapeutic tool to treat heart diseases. In general, increasing the level of available energy sources for muscle contraction by increasing the concentration of free ATP or creatine phosphate would be of great benefit in treating heart failure.

#### EXAMPLE 7

EST 61166 (FIG. 6 A) was identified by suppression subtractive hybridization comparing transcript levels of heart tissue explanted from normal control KN4 with one from DCM patient h94 (see TABLE 1). The fragment was over-represented in the control tissue.

Using LabOnWeb (Compugen) it was possible to assemble 61166contig (FIG. 6 B) that codes for a predicted protein with the amino acid sequence of 61166pep (FIG. 6 C). The assembly of EST is shown in FIG. 6 D with examples of known ESTs (AI 745235,AL 050107, AI 927050)

61166 displays a significant homology to human 65 kDa yes-associated protein YAP65 (NM\_006106, Expect = 2e-84, Identity 57%, Wambutt *et al.*). YAP65 associates *in vitro* with the Src homology domain 3 (SH3) of the Yes proto-oncogene product (yes kinase) and other signaling molecules (Sudol *et al.*). The motif PVKQPPPLAP of human YAP65, which binds to SH3 domains is not conserved in 61166 (amino acids 201-210 marked in italic letters above).

Downregulation upon DCM was confirmed for five DCM patients compared to the same number of normal control hearts by quantitative dot blot analysis (FIG. 6 E). The relative expression level of 61166 is significantly reduced by a factor of 3.9 upon disease. The probability of type 1 error is less than 5% as determined in a Wilcoxon test.

Significant downregulation of 61166 expression in heart tissue of five DCM patients compared to five normal controls indicates that a lowered expression of 61166 is associated with dilated cardiomyopathy. Lowered expression of 61166 by a factor of 4 seems to

induce a cardiomyopathic phenotype. Therefore we expect the protein to play a causative role in heart diseases, especially congestive heart failure.

The high homology to a yes kinase associating protein suggests a central role for 61166 in signal transduction or development. This finding supports our idea that 61166 can be used  
5 as a specific molecular target for drug development and/or diagnostics.

Upregulation of protein expression by gene therapeutic intervention, compensatory molecules or specific activators may be a therapeutic tool to treat heart diseases.

### EXAMPLE 8

10 Screen for expression profiles using a dot blot ybridization in a higher number of patients clearly showed that 61244 is induced upon disease (FIG. 7 E). Transcript levels are significantly upregulated by a factor 3.6 in five DCM patients compared to five normal controls. The probability of type 1 error is less than 5% as determined in a Wilcoxon test.

15 EST 61244 (FIG. 7 A) was identified by suppression subtractive hybridization comparing transcript levels of heart tissue explanted from normal control KN4 with one from DCM patient h94 (see TABLE 1). The fragment was found to be over-represented in the control tissue. The identified cDNA fragment was found to be a part of the EST clone AF161698  
20 (FIG. 7 B), which encodes the amino acid sequence AAD45360 (FIG. 7 C). This amino acid sequence encodes the Apolipoprotein B mRNA editing protein 2 (APOBEC-2). An overview of the mentioned sequences is depicted in FIG. 7 D.

(APOBEC-2) is highly similar and evolutionarily related to APOBEC-1, which mediates the editing of apolipoprotein (apo) B mRNA (Liao *et al.*). Both proteins are members of C  
25 (cytidine)-->U (uridine) editing enzyme subfamily of the cytidine deaminase supergene family.

APOBEC-2 does not display detectable apoB mRNA editing activity. Like other editing enzymes of the cytidine deaminase superfamily, APOBEC-2 has low, but definite, intrinsic cytidine deaminase activity. APOBEC-2 mRNA and protein are expressed exclusively in  
30 heart and skeletal muscle.

**Yeast two-hybrid interaction**

The interaction of AAD45360 (APOBEC-2) was analysed by challenging this bait (against  $4 \times 10^4$  clones). The two-hybrid analysis procedure led to the identification of one interacting partner. This partner was identified by homology search using the first 500 nucleotides sequence of the prey clone. This partner is beta myosin heavy chain (M21665).

The prey cDNA showed 99% homology with beta myosin heavy chain (M21665). Kurabayashi et al., (1988) showed that the beta myosin heavy chain expression is predominantly expressed in the ventricle. Furthermore, the authors show that beta-form MHC mRNA is expressed in adult atrium at a low level but scarcely expressed in fetal atrium. Moreover, mutation of the beta myosin heavy chain have been reported to play a role in heart hypertrophy (Enjuto et al., 2000; Greber-Platzer et al., 2001).

Significant upregulation of 61244 expression in heart tissue of five DCM patients compared to five normal controls indicates that an increased expression of 61244 is associated with dilated cardiomyopathy. Increased expression of 61244 by a factor of 3-4 seems to induce a cardiomyopathic phenotype. Therefore we expect the protein to play a causative role in heart diseases, especially congestive heart failure.

Moreover, the protein is described to be specifically expressed in heart and skeletal muscle. Thus, 61244 may be a novel RNA editing enzyme with natural substrates in these tissues, that plays an important role in RNA modification. This finding supports our idea that 61244 is a specific molecular target for drug development and/or diagnostics.

Downregulation of protein expression by specific inhibitors or antisense constructs seems to be a very promising therapeutic tool to treat heart diseases.

**EXAMPLE 9**

Screen for expression profiles in a higher number of patients clearly showed that 65330 is induced upon disease (FIG. 8 E). Transcript levels are significantly upregulated by a factor 2.2 in five DCM patients and 1.8 in two ICM patients compared to five normal controls. The probability of type 1 error is less than 5% as determined in a Wilcoxon test and t-test.

EST 65330 (FIG. 8 A) was identified by suppression subtractive hybridization comparing transcript levels of heart tissue explanted from normal control KN6 with one from DCM patient h100 (see TABLE 1).

5 The identified EST was found to be a part of the EST clone AF249873 (FIG. 8 D), which is itself a part of a 65330contig of assembled EST sequences (FIG. 8 B). The EST clone AF249873 encodes the amino acid sequence AAF63623 (FIG. 8 C).

AF249873 encodes a novel gene located on human chromosome 4q with specific expression in cardiac and skeletal muscle (Ahmad *et al.*).

10

#### **Yeast two-hybrid interaction**

4 x 10<sup>4</sup> clones were challenged against the bait AAF 63623 (SMP). The all two-hybrid analysis procedure led to the identification of one interacting partner:  $\alpha$ -actinin 2 (M86406). This interactor was identified by homology search using the first 500  
15 nucleotides sequence of the prey clone.

#### $\alpha$ -actinin 2

Homology search with sequences in the database showed 100% identity with  $\alpha$ -actinin 2 (ACTN2) (NM\_001103). The homology starts at nucleotide 1469 of  $\alpha$ -actinin 2.  $\alpha$ -actinin  
20 2 was mapped on chromosome 1q42-q43 and was found to be expressed in skeletal muscle as well as in heart muscle (Beggs *et al.*, 1992).

Significant upregulation of 65330 expression in heart tissue of five DCM patients and two ICM patients compared to five normal controls indicates that an increased expression of  
25 65330 is associated with dilated cardiomyopathy. According to its interaction with  $\alpha$ -actinin, this protein might play a role in the cytoskeleton of a muscle cell. Therefore we expect the protein to play a causative role in heart diseases, especially in congestive heart failure.

Moreover, the protein is described to be specifically expressed in heart and skeletal muscle.  
30 This finding supports our idea that 65330 is a specific molecular target for drug

development or diagnostics. Downregulation of protein expression by specific inhibitors or antisense constructs seems to be a very promising therapeutic tool to treat heart diseases.

### EXAMPLE 10

5

EST 66214 (FIG. 9 A) was identified by suppression subtractive hybridization comparing transcript levels of heart tissue explanted from a normal control (KN6) with one from a DCM patient (h100, see TABLE 1). The fragment was found to be over-represented in the DCM tissue.

10 The identified cDNA fragment is a part of the EST clone AF129505; the sequence of the 66214cds is shown in FIG. 9 B.

AF129505 was described to be a novel X-chromosomal human gene (SMPX) encoding the amino acid sequence AAF19343 (9 D) which is a small muscular protein (Patzak *et al.*). The gene consists of five exons and four introns comprising together 52.1 kb and is  
15 preferentially and abundantly expressed in heart and skeletal muscle. The gene maps close to DXS7101 31.9 cM from the short arm telomere of the X-chromosome at Xp22.1. FIG. 9 C shows the amino acid sequence of 66214pep.

Upregulation upon DCM was confirmed for five DCM patients compared to four normal  
20 control hearts by quantitative dot blot analysis (FIG. 9 E). The relative expression level of 66214 is significantly induced by a factor of 4.2 upon disease. The probability of type 1 error is less than 5% as determined in a Wilcoxon test.

The elevated expression observed for healthy patient h92 may represent individual differences throughout the population.

25

#### Yeast two-hybrid interaction

The  $4 \times 10^4$  clones were analysed for the screen with 66214pep. The two-hybrid analysis procedure led to the identification of 3 different interactors: Daxx (AB015051), Rad6 (U38785), Ubc9 (P50550). These partners were identified by homology search using the  
30 first 500 nucleotides sequence of the pray clone.

Daxx

Search in the data base showed 99% identity with Daxx (AB015051) over the 400 nucleotides. The homology started at nucleotide 1936 of the Daxx sequence. Daxx was mapped on chromosome 6p21.3 (Kiriakidou et al., 1997). The identity found at nucleotide level was confirmed at amino acid level. Daxx was initially found as an interactor of Fas. (Yang et al.1997). Like Fas, it is believed to activate the JNK signal transduction cascade. Therefore, Daxx might play a role in apoptosis regulation.

Ubc9

The prey showed 100% identity with the human Ubc9 sequence. the clone covered the all Ubc9 sequence. Ubc9 is thought to be involved in the ubiquitin-dependent protein degradation system (Wang et al. 1996). A single copy of the hUBC9 gene was found and localised to human chromosome 16p13.3. Interestingly the interaction of Daxx (see above) was already found with the Ubc9 protein (Ryu et al., 2000).

Rad6

Homology search led to the identification of RAD6 (U38785). This result was confirmed by the amino acid analysis. The involvement of RAD6 in the degradation of endogenous inducible cAMP early repressor (ICER) protein in primary cardiomyocytes and myogenic cell lines has been reported (Folco and Koren, 1997 ). Moreover, recent data showed that Ubiquitin-Conjugating Enzymes (rad6) Target Repressors of Cyclic AMP-Induced Transcription for Proteolysis (Pati et al.,1999)

Significant upregulation of 66214 expression in heart tissue of six DCM patients compared to five normal controls indicates that an increased expression of 66214 is associated with dilated cardiomyopathy. Therefore we expect the protein to play a causative role in heart diseases, especially congestive heart failure.

Moreover, the protein is described to be preferentially and abundantly expressed in heart and skeletal muscle. This finding supports our idea that 66214 is a specific molecular target for drug development and/or diagnostics. Downregulation of protein expression by specific

inhibitors or antisense constructs seems to be a very promising therapeutic tool to treat heart diseases.

### EXAMPLE 11

5

66268 and 52474 (FIG. 10 A) were identified by suppression subtractive hybridization comparing transcript levels of heart tissue explanted from normal control KN6 with DCM patient h100, and KN2 with DHZM3 (see TABLE 1), respectively. Both fragments were found to be over-represented in the DCM tissue. Both identified fragments are parts of the  
10 EST clone X83703 (FIG. 10 B), which encodes the amino acid sequence CAA58676 (FIG. 10 C).

CAA58676 has been identified as a novel cytokine-inducible nuclear protein from human endothelial cells (C-193 or CARP, Chu *et al.*). C-193 represents a new member of the  
15 primary response gene family, since its mRNA expression is induced by IL1 $\alpha$ , TNF $\alpha$ , LPS and CHX.

Dot blot hybridizations showed a slight increase in mean expression intensities of DCM patients versus normal controls for both fragments, but the variability from patient to  
20 patient was high and the dot blot result statistically was not significant applying a Wilcoxon or t-test. FIG. 10 E depicts the example of the hybridization with clone 66268.

An overlapping fragment S1MC01-1 was identified to be induced upon DCM by means of differential display (FDD, see 4.). The differential display expression profile independently  
25 confirms upregulation of this gene by a factor of 2.2 upon DCM and ICM and 3.3 upon HCM. The probability of type 1 error for upregulation upon DCM is less than 5% as determined in a t-test.

**Recombinant over expression in primary cardiomyocytes from neonatal rats:**

A CAA58676-YFP fusion protein was over expressed in primary cardiomyocytes from neonatal rats (pCMs). The pCMs were stimulated with Phenylephrine (PE) which leads to flat cells with an extensive parallel sarcomer organization as could be detected in the upper left and lower right corner of figure 3. The cell over-expressing CAA58676 was detected by the fluorescence signal of the CAA58676-YFP fusion protein. The protein accumulated in litte aggregates in the nucleus. In addition, a thin, elongated shape of the cell was detectable, which pointed to the induction of a serial sarcomere organization after over expression of CAA58676. This observation augmented our opinion, that the over-expression of CAA58676 in the human failing heart has a causative role in disease establishment and progression, because the elongated shape of cardiomyocytes in combination with the serial sarcomere organization is a well known characteristic of diseased cells in the insufficient human heart.

Upregulation of 66268 and 52474 expression in heart tissue of DCM, ICM and HCM patients compared to normal controls indicates that an increased expression of 66268 and 52474 is associated with dilated, ischemic and hypertrophic cardiomyopathy. Increased expression of 66268 and 52474 by a factor of 2-3 seems to induce a cardiomyopathic phenotype. This was strongly supported by our functional analysis in pCMs. A recombinant over expression of a CAA58676-YFP fusion protein led to a serial sarcomere organization which is the main morphological characteristic of diseased cells in the failing human heart. Therefore we expect the protein to play a causative role in cardiomyopathies.

Moreover, the induction by cytokines as well as its mRNA and protein instability elements indicate an important regulatory function for 66268 and 52474 in signal transduction and control of secondary gene expression. Its ankyrin-like repeats may be involved in protein-protein interactions. These findings support our idea to use 66268 and 52474 as a specific molecular target for drug development and/or diagnostics.

Downregulation of protein expression by specific inhibitors or antisense constructs seems to be a very promising therapeutic tool to treat heart diseases.

**Claims**

1. A method for identifying a subject at risk for a disease of the heart, comprising the step of quantitating the amount of at least one RNA encoding an amino acid sequence selected from the group consisting of:
- 5
- (a) the amino acid sequence of SEQ ID NO: 1 [NP\_003961], the amino acid sequence of SEQ ID NO: 2 [41441pep], the amino acid sequence of SEQ ID NO: 3 [56461pep], the amino acid sequence of SEQ ID NO: 4 [AAA52025], the amino acid sequence of SEQ ID NO: 5 [61166pep], the amino acid sequence of SEQ ID NO: 6 [AAD45360], the amino acid sequence of SEQ ID NO: 7 [AAF63623], the amino acid sequence of SEQ ID NO: 8 [66214pep] or the amino acid sequence AAF19343, or the amino acid sequence of SEQ ID NO: 9 [CAA58676];
- 10
- (b) an amino acid sequence that is at least 60%, preferably at least 80%, especially at least 90%, advantageously at least 99% identical to the amino acid sequence of (a);
- 15
- (c) the amino acid sequence of (a) with at least one conservative amino acid substitution;
- (d) an amino acid sequence that is an isoform of the amino acid sequence of any of (a) to (c);
- 20
- (e) the RNA transcribed from the DNA sequence of SEQ ID NO: 10 [NM\_003970], the DNA sequence of SEQ ID NO: 11 [AW755252], the DNA sequence of SEQ ID NO: 12 [EST clone 52706], the DNA sequence of SEQ ID NO: 13 [EST clone 56461], the DNA sequence of SEQ ID NO: 14 [M14780], the DNA sequence of SEQ ID NO: 15 [61166contig], the DNA sequence of SEQ ID NO: 16 [AF161698], the DNA sequence of SEQ ID NO: 17 [65330contig], the DNA sequence of SEQ ID NO: 18 [66214cds] or the DNA sequence AF129505, or the DNA sequence of SEQ ID NO: 19 [X83703] or a degenerate variant thereof; and
- 25
- (f) an amino acid that is encoded by a DNA molecule the complementary strand of which hybridizes in 4xSSC, 0.1% SDS at 65°C to the DNA molecule
- 30

encoding the amino acid sequence of (a), (c) or (d),  
in the heart tissue of the subject.

2. The method according to claim 1, wherein the amount of the said RNA is  
5 quantitated using a nucleic acid probe which is a nucleic acid comprising a sequence  
selected from the group consisting of:

- (a) the DNA sequence of the RNA transcribed from the DNA sequence of SEQ  
ID NO: 10 [NM\_003970], the DNA sequence of SEQ ID NO: 11  
[AW755252], the DNA sequence of SEQ ID NO: 12 [EST clone 52706], the  
10 DNA sequence of SEQ ID NO: 13 [EST clone 56461], the DNA sequence of  
SEQ ID NO: 14 [M14780], the DNA sequence of SEQ ID NO: 15  
[61166contig], the DNA sequence of SEQ ID NO: 16 [AF161698], the DNA  
sequence of SEQ ID NO: 17 [65330contig], the DNA sequence of SEQ ID  
NO: 18 [66214cds] or the DNA sequence AF129505, or the DNA sequence  
15 of SEQ ID NO: 19 [X83703] or a degenerate variant thereof;
- (b) a DNA sequence at least 60%, preferably at least 80%, especially at least  
90%, advantageously at least 99% identical to the DNA sequence of (a);
- (c) a nucleic acid sequence that encodes the amino acid sequence SEQ ID NO: 1  
[NP\_003961], the amino acid sequence of SEQ ID NO: 2 [41441pep], the  
20 amino acid sequence of SEQ ID NO: 3 [56461pep], the amino acid sequence  
of SEQ ID NO: 4 [AAA52025], the amino acid sequence of SEQ ID NO: 5  
[61166pep], the amino acid sequence of SEQ ID NO: 6 [AAD45360], the  
amino acid sequence of SEQ ID NO: 7 [AAF63623], the amino acid  
sequence of SEQ ID NO: 8 [66214pep] or the amino acid sequence  
25 AAF19343, or the amino acid sequence of SEQ ID NO: 9 [CAA58676];  
each of said amino acid sequences having at least one conservative amino  
acid substitution;
- (d) a nucleic acid sequence that encodes an amino acid sequence that is at least  
60%, preferably at least 80%, especially at least 90%, advantageously at  
30 least 99% identical to the amino acid sequence of (c);
- (e) a nucleic acid sequence that encodes the amino acid sequence of (c) or (d)

with at least one conservative amino acid substitution;

(f) a nucleic acid sequence that hybridizes in 4xSSC, 0.1% SDS at 65°C to the complementary strand of the DNA molecule encoding the amino acid sequence of (c), (d) or (e); and

5 (g) a fragment of at least 15 nucleotides in length of (a) to (f), wherein the nucleic acid is detectably labeled; or

(h) a nucleic acid probe comprising a sequence that specifically hybridizes under physiological conditions to the nucleotide sequence selected from the group consisting of:

10 (i) the DNA sequence of the RNA transcribed from the DNA sequence of SEQ ID NO: 10 [NM\_003970], the DNA sequence of SEQ ID NO: 11 [AW755252], the DNA sequence of SEQ ID NO: 12 [EST clone 52706], the DNA sequence of SEQ ID NO: 13 [EST clone 56461], the DNA sequence of SEQ ID NO: 14 [M14780], the DNA  
15 sequence of SEQ ID NO: 15 [61166contig], the DNA sequence of SEQ ID NO: 16 [AF161698], the DNA sequence of SEQ ID NO: 17 [65330contig], the DNA sequence of SEQ ID NO: 18 [66214cds] or the DNA sequence AF129505, or the DNA sequence of SEQ ID NO: 19 [X83703]

20 (ii) a DNA sequence at least 60%, preferably at least 80%, especially at least 90%, advantageously at least 99% identical to the DNA sequence of (i);

(iii) a nucleic acid sequence that encodes the amino acid sequence SEQ  
25 ID NO: 1 [NP\_003961], the amino acid sequence of SEQ ID NO: 2 [41441pep], the amino acid sequence of SEQ ID NO: 3 [56461pep], the amino acid sequence of SEQ ID NO: 4 [AAA52025], the amino acid sequence of SEQ ID NO: 5 [61166pep], the amino acid sequence of SEQ ID NO: 6 [AAD45360], the amino acid sequence of SEQ ID NO: 7 [AAF63623], the amino acid sequence of SEQ ID  
30 NO: 8 [66214pep] or the amino acid sequence AAF19343, or the amino sequence of SEQ ID NO: 9 [CAA58676] with at least one

conservative amino acid substitution;

- 5 (iv) a nucleic acid sequence that encodes an amino acid sequence that is at least 60%, preferably at least 80%, especially at least 90%, advantageously at least 99% identical to the amino acid sequence of (iii);
- (v) a nucleic acid sequence that encodes the amino acid sequence of (iii) with at least one conservative amino acid substitution; and
- 10 (vi) a nucleic acid sequence that hybridizes in 2xSSC, 0.1% SDS at 65°C to the DNA molecule encoding the amino acid sequence of (iii), (iv) or (v),
- (vii) a fragment of at least 15 nucleotides in length of (i) to (vi).

3. A method for identifying a subject at risk for a disease of the heart, comprising the step of quantitating the amount of a polypeptide selected from the group consisting of:
- 15

- (a) the polypeptide having amino acid sequence SEQ ID NO: 1 [NP\_003961], the amino acid sequence of SEQ ID NO: 2 [41441pep], the amino acid sequence of SEQ ID NO: 3 [56461pep], the amino acid sequence of SEQ ID NO: 4 [AAA52025], the amino acid sequence of SEQ ID NO: 5 [61166pep],
- 20 the amino acid sequence of SEQ ID NO: 6 [AAD45360], the amino acid sequence of SEQ ID NO: 7 [AAF63623], the amino acid sequence of SEQ ID NO: 8 [66214pep] or the amino acid sequence AAF19343, or the amino acid sequence of SEQ ID NO: 9 [CAA58676];
- (b) a polypeptide having an amino acid sequence that is at least 60%, preferably at least 80%, especially at least 90%, advantageously at least 99%
- 25 identical to the amino acid sequence of (a); and
- (c) a polypeptide having the amino acid sequence of (a) with at least one conservative amino acid substitution,

in the heart tissue of the subject.

4. The method according to claim 3, wherein the amount of the said polypeptide is quantitated using an antibody or an antigen-binding portion of said antibody that specifically binds a polypeptide selected from the group consisting of:
- 5 (a) the polypeptide having amino acid sequence SEQ ID NO: 1 [NP\_003961], the amino acid sequence of SEQ ID NO: 2 [41441pep], the amino acid sequence of SEQ ID NO: 3 [56461pep], the amino acid sequence of SEQ ID NO: 4 [AAA52025], the amino acid sequence of SEQ ID NO: 5 [61166pep], the amino acid sequence of SEQ ID NO: 6 [AAD45360], the amino acid sequence of SEQ ID NO: 7 [AAF63623], the amino acid sequence of SEQ ID NO: 8 [66214pep] or the amino acid sequence AAF19343, or the amino acid sequence of SEQ ID NO: 9 [CAA58676];
- 10 (b) a polypeptide having an amino acid sequence that is at least 60%, preferably at least 80%, especially at least 90%, advantageously at least 99% identical to the amino acid sequence of (a); and
- 15 (c) a polypeptide having the amino acid sequence of (a) with at least one conservative amino acid substitution.
5. The method according to claim 4, wherein said antibody or antibody binding portion is or is derived from a human antibody or a humanized antibody.
- 20 6. The method according to claim 4 or claim 5, wherein the antibody, the binding portion or derivative thereof is detectably labeled.
7. The method of claim 6, wherein said derivative of said antibody is an scFv fragment.
- 25 8. The method of claim 1 or 2, wherein said RNA is obtained from heart tissue.
9. The method of any one of claims 3 to 7 wherein said polypeptide is quantitated in heart tissue.
- 30

10. The method of any one of claims 1, 2 and 8 further comprising the step of normalizing the amount of RNA against a corresponding RNA from a healthy subject or cells derived from a healthy subject.
- 5 11. The method of any one of claims 3 to 7 and 9 further comprising the step of normalizing the amount of polypeptide against a corresponding polypeptide from a healthy subject or cells derived from a healthy subject.
12. A method for identifying a compound that increases or decreases the level in heart  
10 tissue of a polypeptide selected from the group consisting of:
- (a) the polypeptide having amino acid sequence SEQ ID NO: 1 [NP\_003961], the amino acid sequence of SEQ ID NO: 2 [41441pep], the amino acid sequence of SEQ ID NO: 3 [56461pep], the amino acid sequence of SEQ ID NO: 4 [AAA52025], the amino acid sequence of SEQ ID NO: 5 [61166pep],  
15 the amino acid sequence of SEQ ID NO: 6 [AAD45360], the amino acid sequence of SEQ ID NO: 7 [AAF63623], the amino acid sequence of SEQ ID NO: 8 [66214pep] or the amino acid sequence AAF19343, or the amino acid sequence of SEQ ID NO: 9 [CAA58676];
- (b) a polypeptide having an amino acid sequence that is at least 60%, preferably  
20 at least 80%, especially at least 90%, advantageously at least 99% identical to the amino acid sequence of (a); and
- (c) a polypeptide having the amino acid sequence of (a) with at least one conservative amino acid substitution,
- said method comprising the steps of:
- 25 (1) contacting a DNA encoding said polypeptide under conditions that would permit the translation of said polypeptide with a test compound; and
- (2) detecting an increased or decreased level of the polypeptide relative to the level of translation obtained in the absence of the test compound.
- 30 13. A method for identifying a compound that specifically binds to a polypeptide having an amino acid sequence selected from the group consisting of SEQ ID NO: 1

[NP\_003961], the amino acid sequence of SEQ ID NO: 2 [41441pep], the amino acid sequence of SEQ ID NO: 3 [56461pep], the amino acid sequence of SEQ ID NO: 4 [AAA52025], the amino acid sequence of SEQ ID NO: 5 [61166pep], the amino acid sequence of SEQ ID NO: 6 [AAD45360], the amino acid sequence of  
5 SEQ ID NO: 7 [AAF63623], the amino acid sequence of SEQ ID NO: 8 [66214pep] or the amino acid sequence AAF19343, or the amino acid sequence of SEQ ID NO: 9 [CAA58676]; said method comprising the steps of

- (1) providing said polypeptide; and
- (2) identifying a compound that is capable of binding said polypeptide.

10

14. A monoclonal antibody or derivative thereof that specifically binds to a polypeptide having an amino acid sequence selected from the group consisting of SEQ ID NO: 1 [NP\_003961], the amino acid sequence of SEQ ID NO: 2 [41441pep], the amino acid sequence of SEQ ID NO: 3 [56461pep], the amino acid sequence of SEQ ID  
15 NO: 4 [AAA52025], the amino acid sequence of SEQ ID NO: 5 [61166pep], the amino acid sequence of SEQ ID NO: 6 [AAD45360], the amino acid sequence of SEQ ID NO: 7 [AAF63623], the amino acid sequence of SEQ ID NO: 8 [66214pep] or the amino acid sequence AAF19343, or the amino acid sequence of SEQ ID NO: 9 [CAA58676].

20

15. A method for identifying a compound that increases or decreases the level in heart tissue of an mRNA encoding a polypeptide selected from the group consisting of:
- (a) the polypeptide having amino acid sequence SEQ ID NO: 1 [NP\_003961], the amino acid sequence of SEQ ID NO: 2 [41441pep], the amino acid  
25 sequence of SEQ ID NO: 3 [56461pep], the amino acid sequence of SEQ ID NO: 4 [AAA52025], the amino acid sequence of SEQ ID NO: 5 [61166pep], the amino acid sequence of SEQ ID NO: 6 [AAD45360], the amino acid sequence of SEQ ID NO: 7 [AAF63623], the amino acid sequence of SEQ ID NO: 8 [66214pep] or the amino acid sequence AAF19343, or the amino acid sequence of SEQ ID NO: 9 [CAA58676];
  - (b) a polypeptide having an amino acid sequence that is at least 60%, preferably

30

at least 80%, especially at least 90%, advantageously at least 99% identical to the amino acid sequence of (a); and

- (c) a polypeptide having the amino acid sequence of (a) with at least one conservative amino acid substitution,

5 said method comprising the steps of

- (1) contacting a DNA giving rise to said mRNA under conditions that would permit transcription of said mRNA with a test compound; and  
(2) detecting an increased/decreased level of the mRNA relative to the level of transcription obtained in the absence of the test compound.

10

16. A transgenic non-human mammal whose somatic and germ cells comprise at least one gene encoding a functional or disrupted polypeptide selected from the group consisting of:

- (a) the polypeptide having amino acid sequence SEQ ID NO: 1 [NP\_003961],  
15 the amino acid sequence of SEQ ID NO: 2 [41441pep], the amino acid sequence of SEQ ID NO: 3 [56461pep], the amino acid sequence of SEQ ID NO: 4 [AAA52025], the amino acid sequence of SEQ ID NO: 5 [61166pep], the amino acid sequence of SEQ ID NO: 6 [AAD45360], the amino acid sequence of SEQ ID NO: 7 [AAF63623], the amino acid sequence of SEQ  
20 ID NO: 8 [66214pep] or the amino acid sequence AAF19343, or the amino acid sequence of SEQ ID NO: 9 [CAA58676];

- (b) a polypeptide having an amino acid sequence that is at least 60%, preferably at least 80%, especially at least 90%, advantageously at least 99% identical to the amino acid sequence of (a); and

- 25 (c) a polypeptide having the amino acid sequence of (a) with at least one conservative amino acid substitution,

that said functional or disrupted polypeptide has been modified, said modification being sufficient to decrease or increase the amount of said functional polypeptide expressed in the heart tissue of said transgenic non-human mammal, wherein said  
30 transgenic non-human mammal exhibits a disease of the heart.

17. The transgenic non-human mammal according to claim 16, wherein said disrupted or functional gene was introduced into the non-human mammal or an ancestor thereof, at an embryonic stage.
- 5 18. A transgenic non-human mammal according to claim 16 or 17, wherein the modification is inactivation, suppression or activation of said gene(s) or leads to the reduction or enhancement of the synthesis of the corresponding protein(s).
19. A method for identifying a compound that increases or decreases the expression of a  
10 polypeptide in heart tissue, the polypeptide being selected from the group consisting of:
- (a) the polypeptide having amino acid sequence SEQ ID NO: 1 [NP\_003961], the amino acid sequence of SEQ ID NO: 2 [41441pep], the amino acid sequence of SEQ ID NO: 3 [56461pep], the amino acid sequence of SEQ ID  
15 NO: 4 [AAA52025], the amino acid sequence of SEQ ID NO: 5 [61166pep], the amino acid sequence of SEQ ID NO: 6 [AAD45360], the amino acid sequence of SEQ ID NO: 7 [AAF63623], the amino acid sequence of SEQ ID NO: 8 [66214pep] or the amino acid sequence AAF19343, or the amino acid sequence of SEQ ID NO: 9 [CAA58676];
- 20 (b) a polypeptide having an amino acid sequence that is at least 60%, preferably at least 80%, especially at least 90%, advantageously at least 99% identical to the amino acid sequence of (a); and
- (c) a polypeptide having the amino acid sequence of (a) with at least one conservative amino acid substitution,
- 25 said method comprising the steps of:
- (1) contacting a transgenic non-human mammal according to any one of claims 14 to 16 with a test compound, and
- (2) detecting an increased or decreased level of expression of said polypeptide relative to the expression in the absence of said test compound.

20. The method according to claim 19, wherein the test compound prevents or ameliorates a disease of the heart in said transgenic non-human mammal.

21. A method for identifying one or a plurality of isogenes of a gene coding for a polypeptide selected from the group consisting of: the polypeptide having the amino acid sequence of SEQ ID NO: 1 [NP\_003961], the amino acid sequence of SEQ ID NO: 2 [41441pep], the amino acid sequence of SEQ ID NO: 3 [56461pep], the amino acid sequence of SEQ ID NO: 4 [AAA52025], the amino acid sequence of SEQ ID NO: 5 [61166pep], the amino acid sequence of SEQ ID NO: 6 [AAD45360], the amino acid sequence of SEQ ID NO: 7 [AAF63623], the amino acid sequence of SEQ ID NO: 8 [66214pep] or the amino acid sequence AAF19343, or the amino acid sequence of SEQ ID NO: 9 [CAA58676]; said method comprising the steps of

- (1) providing nucleic acid coding for said polypeptide or a part thereof; and
- (2) identifying a second nucleic acid that (i) has a homology of 60%, preferably at least 80%, especially at least 90%, advantageously at least 99% or (ii) hybridizes in 4xSSC, 0.1 SDS at 45°C to the nucleic acid molecule encoding said amino acid sequences.

22. A method for identifying one or a plurality of genes whose expression in heart tissue is modulated by inhibiting, decreasing or increasing the expression of a polypeptide selected from the group consisting of:

- (a) the polypeptide having amino acid sequence SEQ ID NO: 1 [NP\_003961], the amino acid sequence of SEQ ID NO: 2 [41441pep], the amino acid sequence of SEQ ID NO: 3 [56461pep], the amino acid sequence of SEQ ID NO: 4 [AAA52025], the amino acid sequence of SEQ ID NO: 5 [61166pep], the amino acid sequence of SEQ ID NO: 6 [AAD45360], the amino acid sequence of SEQ ID NO: 7 [AAF63623], the amino acid sequence of SEQ ID NO: 8 [66214pep] or the amino acid sequence AAF19343, or the amino acid sequence of SEQ ID NO: 9 [CAA58676];
- (b) a polypeptide having an amino acid sequence that is at least 60%, preferably

at least 80%, especially at least 90%, advantageously at least 99% identical to the amino acid sequence of (a); and

(c) a polypeptide having the amino acid sequence of (a) with at least one conservative amino acid substitution,

5 or of an mRNA encoding said polypeptide,

said modulation being indicative of a disease of the heart, said method comprising the steps of:

(1) contacting a plurality of heart tissue cells with a compound that inhibits, decreases or increases the expression of said polypeptide under conditions that permit the expression of said polypeptide in the absence of a test  
10 compound, and

(2) comparing a gene expression profile of said heart cell in the presence and in the absence of said compound.

15 23. A method for identifying one or a plurality of genes whose expression in heart tissue is modulated by the inhibition, decrease or increase of the expression of a polypeptide selected from the group consisting of:

(a) the polypeptide having amino acid sequence SEQ ID NO: 1 [NP\_003961], the amino acid sequence of SEQ ID NO: 2 [41441pep], the amino acid  
20 sequence of SEQ ID NO: 3 [56461pep], the amino acid sequence of SEQ ID NO: 4 [AAA52025], the amino acid sequence of SEQ ID NO: 5 [61166pep], the amino acid sequence of SEQ ID NO: 6 [AAD45360], the amino acid sequence of SEQ ID NO: 7 [AAF63623], the amino acid sequence of SEQ ID NO: 8 [66214pep] or the amino acid sequence AAF19343, or the amino  
25 acid sequence of SEQ ID NO: 9 [CAA58676];

(b) a polypeptide having an amino acid sequence that is at least 60%, preferably at least 80%, especially at least 90%, advantageously at least 99% identical to the amino acid sequence of (a); and

(c) a polypeptide having the amino acid sequence of (a) with at least one  
30 conservative amino acid substitution,

or of an mRNA encoding said polypeptide, said modulation being indicative of a

disease of the heart, said method comprising the steps of:

- (1) providing expression profiles of
  - (i) a plurality of heart tissue cells from or derived from a heart of a subject  
5 suffering from a disease of the heart; and
  - (ii) a plurality of heart tissue cells from or derived from a subject not  
suffering from a disease of the heart; and
- (2) comparing the expression profiles (i) and (ii).

10 24. The method of claim 22 further comprising the steps of

- (3) determining at least one gene that is expressed at a lower or higher level in the presence of said compound; and
- (4) identifying a further compound that is capable of raising or lowering the expression level of said at least one gene.

15

25. The method of claim 23 further comprising the steps of

- (3) determining at least one gene that is expressed at a lower or higher level in said heart tissue cells from or derived from a heart of a subject suffering from a disease of the heart; and
- (4) identifying a further compound that is capable of raising or lowering the  
20 expression level of said at least one gene.

20

26. The method of claim 23 further comprising the steps of

- (3) determining at least one gene that is expressed at a higher or lower level in  
25 said heart tissue cells from or derived from a heart of a subject suffering from a disease of the heart; and
- (4) identifying a further compound that is capable of reducing or raising the expression level of said at least one gene.

25

30 27. A method for identifying a protein or a plurality of proteins in heart tissue whose activity is modulated by a polypeptide having the amino acid sequence selected

from the group consisting of SEQ ID NO: 1 [NP\_003961], the amino acid sequence of SEQ ID NO: 2 [41441pep], the amino acid sequence of SEQ ID NO: 3 [56461pep], the amino acid sequence of SEQ ID NO: 4 [AAA52025], the amino acid sequence of SEQ ID NO: 5 [61166pep], the amino acid sequence of SEQ ID NO: 6 [AAD45360], the amino acid sequence of SEQ ID NO: 7 [AAF63623], the amino acid sequence of SEQ ID NO: 8 [66214pep] or the amino acid sequence AAF19343, or the amino acid sequence of SEQ ID NO: 9 [CAA58676];

said method comprising the steps of

- (1) providing said polypeptide; and
- (2) identifying a further protein that is capable of interacting with said polypeptide.

28. The method of any one of claims 12, 13, 15, 19, 20, 22 or 24 to 26, wherein said compound is a small molecule or a peptide derived from an at least partially randomized peptide library.

29. A method of refining a compound identified by the method of any one of claims 12, 13, 15, 19, 20, 22, 24 to 26 or 28; said method comprising the steps of

- (1) identification of the binding sites of the compound and the DNA or mRNA molecule by site-directed mutagenesis or chimeric protein studies;
- (2) molecular modeling of both the binding site of the compound and the binding site of the DNA or mRNA molecule; and
- (3) modification of the compound to improve its binding specificity for the DNA or mRNA.

30. The method of any one of claims 12, 13, 15, 19, 20, 22, 24 to 26, 28 or 29, wherein said compound is further refined by peptidomimetics.

31. A method of modifying a compound identified or refined by any one of claims 12, 13, 15, 19, 20, 22, 24 to 26, 28 to 30 as a lead compound to achieve

- (i) modified site of action, spectrum of activity, organ specificity, and/or
  - (ii) improved potency, and/or
  - (iii) decreased toxicity (improved therapeutic index), and/or
  - (iv) decreased side effects, and/or
  - 5 (v) modified onset of therapeutic action, duration of effect, and/or
  - (vi) modified pharmacokinetic parameters (resorption, distribution, metabolism and excretion), and/or
  - (vii) modified physico-chemical parameters (solubility, hygroscopicity, color, taste, odor, stability, state), and/or
  - 10 (viii) improved general specificity, organ/tissue specificity, and/or
  - (ix) optimized application form and route
- by
- (i) esterification of carboxyl groups, or
  - 15 (ii) esterification of hydroxyl groups with carbon acids, or
  - (iii) esterification of hydroxyl groups to, e.g. phosphates, pyrophosphates or sulfates or hemi succinates, or
  - (iv) formation of pharmaceutically acceptable salts, or
  - (v) formation of pharmaceutically acceptable complexes, or
  - 20 (vi) synthesis of pharmacologically active polymers, or
  - (vii) introduction of hydrophylic moieties, or
  - (viii) introduction/exchange of substituents on aromates or side chains, change of substituent pattern, or
  - (ix) modification by introduction of isosteric or bioisosteric moieties, or
  - 25 (x) synthesis of homologous compounds, or
  - (xi) introduction of branched side chains, or
  - (xii) conversion of alkyl substituents to cyclic analogues, or
  - (xiii) derivatisation of hydroxyl group to ketals, acetals, or
  - (xiv) N-acetylation to amides, phenylcarbamates, or
  - 30 (xv) synthesis of Mannich bases, imines, or
  - (xvi) transformation of ketones or aldehydes to Schiff's bases, oximes, acetals,

ketales, enolesters, oxazolidines, thiozolidines  
or combinations thereof.

- 5 32. A method for inducing a disease of the heart in a non-human mammal, comprising  
the step of contacting the heart tissue of said mammal with a compound that  
inhibits, decreases or increases the expression of a polypeptide selected from the  
group consisting of:
- 10 (a) the polypeptide having amino acid sequence SEQ ID NO: 1 [NP\_003961],  
the amino acid sequence of SEQ ID NO: 2 [41441pep], the amino acid  
sequence of SEQ ID NO: 3 [56461pep], the amino acid sequence of SEQ ID  
NO: 4 [AAA52025], the amino acid sequence of SEQ ID NO: 5 [61166pep],  
the amino acid sequence of SEQ ID NO: 6 [AAD45360], the amino acid  
sequence of SEQ ID NO: 7 [AAF63623], the amino acid sequence of SEQ  
ID NO: 8 [66214pep] or the amino acid sequence AAF19343, or the amino  
15 acid sequence of SEQ ID NO: 9 [CAA58676];
- (b) a polypeptide having an amino acid sequence that is at least 60%, preferably  
at least 80%, especially at least 90%, advantageously at least 99% identical  
to the amino acid sequence of (a); and
- 20 (c) a polypeptide having the amino acid sequence of (a) with at least one  
conservative amino acid substitution.
33. The method according to claim 32, wherein said compound that inhibits, decreases  
or increases is a small molecule, an antibody or an aptamer that specifically binds  
said polypeptide.
- 25 34. A method of producing a pharmaceutical composition comprising formulating the  
compound identified, refined or modified by the method of any of the preceding  
claims with a pharmaceutically active carrier or diluent.
- 30 35. A method for preventing or treating a disease of the heart in a subject in need of  
such treatment, comprising the step of increasing or decreasing the level of a

polypeptide in the heart tissue of a subject, said polypeptide being selected from the group consisting of:

- 5 (a) the polypeptide having amino acid sequence SEQ ID NO: 1 [NP\_003961], the amino acid sequence of SEQ ID NO: 2 [41441pep], the amino acid sequence of SEQ ID NO: 3 [56461pep], the amino acid sequence of SEQ ID NO: 4 [AAA52025], the amino acid sequence of SEQ ID NO: 5 [61166pep], the amino acid sequence of SEQ ID NO: 6 [AAD45360], the amino acid sequence of SEQ ID NO: 7 [AAF63623], the amino acid sequence of SEQ ID NO: 8 [66214pep] or the amino acid sequence AAF19343, or the amino acid sequence of SEQ ID NO: 9 [CAA58676];
- 10 (b) a polypeptide having an amino acid sequence that is at least 60%, preferably at least 80%, especially at least 90%, advantageously at least 99% identical to the amino acid sequence of (a); and
- 15 (c) a polypeptide having the amino acid sequence of (a) with at least one conservative amino acid substitution.

36. A method of preventing or treating a disease of the heart in a subject in need of such treatment comprising the step of increasing or decreasing the level of mRNA encoding a polypeptide in the heart tissue of a subject, said polypeptide being selected from the group consisting of:

- 20 (a) the polypeptide having amino acid sequence SEQ ID NO: 1 [NP\_003961], the amino acid sequence of SEQ ID NO: 2 [41441pep], the amino acid sequence of SEQ ID NO: 3 [56461pep], the amino acid sequence of SEQ ID NO: 4 [AAA52025], the amino acid sequence of SEQ ID NO: 5 [61166pep], the amino acid sequence of SEQ ID NO: 6 [AAD45360], the amino acid sequence of SEQ ID NO: 7 [AAF63623], the amino acid sequence of SEQ ID NO: 8 [66214pep] or the amino acid sequence AAF19343, or the amino acid sequence of SEQ ID NO: 9 [CAA58676];
- 25 (b) a polypeptide having an amino acid sequence that is at least 60%, preferably at least 80%, especially at least 90%, advantageously at least 99% identical to the amino acid sequence of (a); and
- 30

(c) a polypeptide having the amino acid sequence of (a) with at least one conservative amino acid substitution.

- 5 37. The method of claims 35 or 36, wherein such increase or decrease is effected by administering the pharmaceutical composition obtained by the method of claim 30.
38. The method of claim 35 or 36, wherein such an increase or decrease is effected by introducing the nucleic acid sequence recited in claim 2 into the germ line or into somatic cells of a subject in need thereof.
- 10 39. The method of any of the preceding claims, wherein said disease of the heart is congestive heart failure, dilative cardiomyopathy, hypertrophic cardiomyopathy, ischemic cardiomyopathy, specific heart muscle disease, rhythm and conduction disorders, syncope and sudden death, coronary heart disease, systemic arterial hypertension, pulmonary hypertension and pulmonary heart disease, valvular heart disease, congenital heart disease, pericardial disease or endocarditis.
- 15 40. A method for identifying subjects at risk for heart diseases, especially congestive heart failure, comprising the step of detecting an increased or decreased level of MYOM2, the LIM domain, the muscle isoform of creatine kinase, YAP65, APOBEC-2, SMPX or C-193 (CARP) in the heart tissue of a subject.
- 20 41. A method for preventing or treating heart diseases, especially congestive heart failure in a subject, said method comprising the step of contacting the heart tissue of said subject with a compound that decreases or increases the expression of MYOM2, the LIM domain, the muscle isoform of creatine kinase, YAP65, APOBEC-2, SMPX or C-193 (CARP).
- 25 42. A method for identifying subjects at risk for heart diseases, especially congestive heart failure, comprising the step of detecting decreased creatine kinase activity in the tissue of a subject especially in a muscle tissue or from blood or serum.
- 30

43. A method for identifying a subject at risk for heart diseases, especially congestive heart failure, said method comprising detecting increased levels of creatine phosphate in a subject, especially in the blood or serum of a subject.

5

44. A method for preventing or treating heart diseases, especially congestive heart failure in a subject, said method comprising the step of increasing the transfer of phosphoryl groups from creatine phosphate to ADP in the heart tissue of a subject.

10

45. The method according to claim 44, wherein the activity of creatine kinase is increased in said heart tissue.

46. A method for identifying a compound for preventing or treating heart diseases, especially congestive heart failure, said method comprising the steps of:

15

- (a) contacting creatine kinase with a substrate for creatine kinase and a test compound, and
- (b) determining whether the transfer of phosphoryl groups from the substrate is increased in the presence of the test compound.

20

47. Use of a compound of one of the claims 12, 13, 15, 19, 20, 24 to 26, 28, 41, 46, a refined or modified compound of one of the claims 29, 30 or 31, or a monoclonal antibody of the claim 14 for the manufacture of a pharmaceutical composition for the prophylaxis or treatment of heart diseases, especially congestive heart failure.

25

Length: 197 nt  
>40399  
1 ACAGACGAAA TGAAGTGAA CTGGTGTAC AAAGATGCTC AGACCTCATC CAGTGAGCAT  
61 ATGAGAAATCC GGGGAGTGA AGAGATGGCT TGGCTGCACA TATGTGAGCC GACTGACAAG  
121 GATAAAGGAA AATACACTTT TGAGATTTTC GATGGCTAAT ACAACCATCA ACGTCCCTT  
181 GACCTGTCCG GACACTG

FIG. 1 A

## FIG 1 B/I

Length: 4939 nt  
 >NM\_003970

```

1  ttctctctcc tccttgcaat ttcttttct gtctgggagc acgccaagat gtccttctgtg
61  actgtcccct tctaccagaa gagacatagg cacttcgacc agtcctaccg taatatcaaa
121 acacgggtacc tgctggacga atatgcgtca aaaagcgag cttccaccaca ggcattcttcc
181 cagaagtcct tgagtcagcg gtcgtcttca cagagagcct ccagccagac gtccttggga
241 ggaaccatct gcagggtctg tgcgaagcga gtgagcacgc aggaagatga ggagcaggag
301 aacagaagca ggtaccagtc cctggtgccc gcctatggtg aggccaaagcg acacggcttc
361 ctcagcgagc tggcccactt ggaggaggat gtcaccctgg cacgctccca ggcccgcgac
421 aagctggaca aatacgccat tcagcagatg atggaggaca agctggcctg ggagagacac
481 acatttgaag agcggataag cagggtcctt gagatcctgg tgcggctgcg atcccacacc
541 gtctgggaga ggatgtctgt gaaactctgc ttcaccgtgc aaggatttcc caccgcccgtg
601 gtgcagtggc acaaagatgg cagtctgatt tgccaggcgg ctgaaccggg aaagtacagg
661 attgagagca actatggcgt acacacactg gagatcaaca gggcagactt tgacgacact
721 gcgacatact cagcagtggc caccaatgcc caccgacaag tgtccaccaca cgcggcgggtg
781 gtggtgagaa ggttcggggg agacgaggaa ccattccggtt cggctgggact cccgattgga
841 ttgcccctgt catcगतatgat tccgtacacg cacttcgacg tccagttttt ggagaagttt
901 ggggtcacct tcaggagggga aggcgagacg gtcactctca agtgcaccat gctggtgacg
961 ccggacctga agcgggtgca gccgcgcgcc gagtgggtacc gcgatgactt gctgttgaaa
1021 gagtccaagt ggacgaaagat gttcttttggg gaaggccagg cctcccctgtc cttcagccac
1081 ctgcacaagg acgacgaggg cctgtacacc ctgcgcatcg tgtctcgggg cggcgtcacg
1141 gaccacagcg ccttcctgtt tgcagagat gctgaccgcg tggtcacagg ggcccccggt

```

FIG. 1 B/2

1201 gcaccatgg acttgcagtg ccacgacgcc aaccgggact acgtcatcgt gacctggaag  
 1261 ccgcccaca ccaccactga gagcccctc atgggctatt ttgtggaccg atgtgaagta  
 1321 ggaacgaata attgggtgca gtgcaatgat gcaccggtga aatctgcaa ataccgggtc  
 1381 acagggcttt ttgaaggaag gtcttacata ttccgagtga gggcagtgaa cagtgcgggc  
 1441 atcagccgac cctccagggt ctctgatgag gtggctgcac ttgacccctt ggacctcaga  
 1501 aggttacaag ccgttcattt ggagggagag aaggagatg ccatttatca ggatgacctt  
 1561 gaaggtgacg ccagggtcc agggcctccc accggtgtgc acgcttccga gatcagcaga  
 1621 aactatgtcg tcctcagctg ggagccaccc actcccctg gcaaggaccg gctcatgtac  
 1681 ttcatgtaga agtcggtggt ggggagcggc acgtggcaga ggtcaacgc ccagacggct  
 1741 gtgagatccc cgagatatgc cgtgtttgac ctcatggaag ggaagtctta tgtgttccga  
 1801 gtgctgtcag caaacggca tggcctgagc gaacctcgg agataacgtc cccattcag  
 1861 gccaggatg tgaccgttgt cccttctgct ccgggtcggg ttcttgctc ccgaaacacc  
 1921 aagacgtcgg tgggtggtgca gtggaccga cctaagcatg aggaggacct gctgggctac  
 1981 tacgtggact gctgtgtggc cggaaccaac ctctgggagc cctgcaacca caagcccatc  
 2041 ggatacaaca ggttcgtggt gcacggctta accacgggag agcagtacat cttccgagtc  
 2101 aaggcgttca atgctgtggg gatgagtga aattcccagg aatcagacgt cataaaagtg  
 2161 cagggccgac tcaccgtccc gtccatcct tatgggatta cgctcctcaa ctgtgacggc  
 2221 cactccatga ccctcggctg gaaggtcccg aaattcagtg gtggctcggc catcctgggc  
 2281 tactacctgg acaagcgtga agttcacccat aaaactggc acgaggtcaa ttcctcacc  
 2341 agcaaaccca caatccctaac ggtggacggc ttgacgggaag gctcactcta cgagttcaaa  
 2401 atcgccgccc tcaacctggc cggcatcggg gagccctcag atcccagtga gcacttcaag  
 2461 tgtgaggcct ggaccatgcc ggagcccggc cctgcctacg acttgacgtt ctgtgaggtc

FIG. 1 B/3

2521 agggacacgt ccttgggtcat gctgtggaag gcccttgtgt actccggcag cagccctgtt  
 2581 tctggatatt tctggactt cagggaggag gatgctggag agtggatcac tgtcgatcag  
 2641 acgacaacag ccagccgtta tttaaaggct tctgacctgc agcaaggtaa gacctatgtc  
 2701 ttcaggggcc gggcagtcaa tgcaaatggc gtgggaagc cctcagacac gtcggagcct  
 2761 gtgctggtag aggcgagacc aggcaccaag gaaatcagtg ctggtgtcga tgaacagggc  
 2821 aacatctatc tgggcttcca ctgccaggaa atgacagacg cgtctcagtt cacctggtgt  
 2881 aaatcctacg aggagatttc agatgatgag aggtttaaaa tcgaaaccgt gggggatcac  
 2941 tccaagctgt acttaagaa tccggataag gaggatttag ggacttactc cgtgtctgta  
 3001 agtgatacag acggagtgtc ctccagtttt gttctggacc cagaaagagct cgagcgtttg  
 3061 atggcattga gcaatgaaat aaagaacccc acaattcctc tgaaatcggg attagcttat  
 3121 gagattttg ataagggcg gtttcgcttc tggctccagg ctgagcactt atcaccagat  
 3181 gccagctacc gatttattat taatgacaga gaagtctctg acagcgagat acacagaatt  
 3241 aatgtgaca aagctactgg cattattgag atggtgatgg atcgatttag tattgaaaat  
 3301 gaggggacct aactgtgca gattcatgat gggaaagcca aaagtcagtc ttctctagtt  
 3361 cttattggag atgcattcaa gactgtgctg gaagaggctg agtttcaaag gaaagaattt  
 3421 ctcaggaaac aaggccctca ttttgctgag tacttgcaac accaagaaag aaaccgtttt caaatggctc  
 3481 gaagtctgac ttgtttgcaa ggttgcaaac accaagaaag ctgcctaacc tggagagggg aatctgtgag  
 3541 aaggatgatg ctctgtatga aacggagaca ctgcctaacc tggagagggg aatctgtgag  
 3601 ctccatcatcc caaagtgtc aaagaaggac cacggtgaat acaaggcaac cttgaaagat  
 3661 gacagaggcc aagatgtgtc catccttgaa atagctggca aagtgtatga tgatatgatt  
 3721 ttggcaatga gtagagtctg tgggaaatct gcttcgccac tgaaggctact ctgcacccca  
 3781 gaaggaatac gacttcagtg tttcatgaag tattttacag acgaaatgaa agtgaactgg

FIG. 1 B/4

3841 tgtcacaag atgctaagat dtcatccagt gagcatalga gaatcggggg gagtgaagag  
 3901 atggcttggc tgagatatg tgagccgact gagaaggata aaggaataa cacttttgag  
 3961 atttcgatg gcaaaagaca ccatcaacgc tcccttgacc tgcaggaca agcttttgat  
 4021 gaagcatttg cagaattcca gcaattcaaa gctgctgctt ttgcagagaa gaatcgtggc  
 4081 aggttgatcg gcggcttgcc tgacgtggtg accatcatgg aaggaagac cttgaatctg  
 4141 acctgcacgg tgtttgaaa ccctgacccc gaagtgat ttggtcaagaa cgaccaggac  
 4201 atccagctca gcgagcact ctgggtgaag gtggagcagg ccaagtacgt cagcatgacc  
 4261 atcaaaaggc tgacctcga ggactcggc aagtacagca tcaacatcaa gaataagtat  
 4321 ggcggggaga agatcgact gacggtgagc gtgtacaac acggggagaa gatcccggac  
 4381 atggccccc cccagcaag caagcccagg ctcatcccgc cgtctgcctc agcggcaggc  
 4441 cagtgaaggc gttttcctag cctggagatg ggaaaatatg cttggcagag acaggaatgc  
 4501 tgtgtgcttg ttccaaatga gcagctggca tccgagtgtg gtctgtgtg ggctgatagt  
 4561 tgatcacaca ttgtgctttt gatttttgc tttggtgatg aatattttat acccgtctaa  
 4621 gggagaaaagc taatgttttc cacaagactg aacaacgtgt atttacaga gggtagacgg  
 4681 cagatgcctg acagagagtg ggttggcaga caacacacta gcattttcac ggggtgtggc  
 4741 acatgggtgt ggcacctgga cgtgtgcagc atgtggcggc ctctgtgtga agccaccgtg  
 4801 cttctctttg gggggccgcg agatctagca tctctgaaat cctggctgtc gaggccttga  
 4861 agcatgtgtt acctggttaa gcttgtttc tcttgcttta ggcaataaa agtttaaaaa  
 4921 tcaaaaaaa aaaaaaaa

Length: 1465 amino acids

>NP\_003961

```

MSLVTVPFYQ KRHRHFDQSY RNIQTRYLLD EYASKKRAST QASSQKSLSQ 51
RSSSQRASSQ TSLGGTICRV CAKRVSTQED EEQENRSRYQ SLVAAYGEAK 101
RHGFLSELAH LEEDVHLARS QARDKLDKYA IQQMEDKLA WERHTFEERI 151
SRAPEILVRL RSHTVWERMS VKLCFTVQGF PTPVVQWYKD GSLICQAAEP 201
GKYRIESNYG VHTLEINRAD FDDTATYSAV ATNAHGQVST NAAVVVRRFR 251
GDEEPPFRSVG LPIGLPLSSM IPYTHFDVQF LEKFGVTFRR EGETVTLKCT 301
MLVTPDLKRV QPRAEWYRDD LLLKESKWK MFFGEGQASL SFSHLHKDDE 351
GLYTLRIVSR GGVTDHSAFL FVRDADPLVT GAPGAPMDLQ CHDANRDYVI 401
VTWKPPNTTT ESPVMGYFVD RCEVGTNNWV QCNDAPVKIC KYPVTGLFEG 451
RSYIFRVRV NSAGISRPSR VSDAVAALDP LDLRRLQAVH LEGEKEIAIY 501
QDDLEGDAQV PGPPTGVHAS EISRNYVVL S WEPPTPRGKD PLMYFIEKSV 551
VSGGTWQRVN AQTAVRSPRY AVFDLMEGKS YVFRVLSANR HGLSEPSEIT 601
SPIQAQDVTV VPSAPGRVLA SRNTKTSVVV QWDRPKHEED LLGYVDCCV 651
AGTNLWEPCN HKPIGYNRFV VHGLTTGEQY IFRVKAVNAV GMSENSQESD 701
VIKVQAALTV PSHPYGITLL NCDGHSMTLG WKVPKFSGGS PILGYLDKR 751
EVHKNWHEV NSSPSKPTIL TVDGLTEGSL YEFKIAAVNL AGIGEPSDPS 801
EHFKCEAWTM PEPGPAYDLT FCEVRDTSLV MLWKAPVYSG SSPVSGYFVD 851
FREEDAGEWI TVDQTTTASR YLKVSDLQQG KTYVFRVRV NANGVGKPSD 901
TSEPVLVEAR PGTKEISAGV DEQGNLYLGF DCQEMTDASQ FTWCKSYEEI 951
SDDERFKIET VGDHSLKLYLK NPDKEDLGT SVSVSDTDGV SSSFVLDPEE 1001
LERLMALSNE IKNPTIPLKS ELAYEIFDKG RVRFWLQAEH LSPDASYRFI 1051
INDREVS DSE IHRIKCDKAT GIEMVMDFR SIENEGTYTV QIHDGKAKSQ 1101
SSLVLIGDAF KTVLEEAQEF RKEFLRKQGP HFAEYLHWDV TEECEVRLVC 1151
KVANTKKETV FKWLKDDALY ETETLPNLER GICELLIPKL SKKDHEGYKA 1201
TLKDDRGQDV SILEIAGKVY DDMILAMSRV CGKSASPLKV LCTPEGIRLQ 1251
CFMKYFTDEM KVNWCHKDAK ISSSEHMRIG GSEEMAWLQI CEPTEKDKGK 1301
YTFEIFDGKD NHQRSLDL SG QAFDEAFAEF QQFKAAAF AE KNRGRLIGGL 1351
PDVVTIMEGK TLNLTCTVFG NPDPEVIWFK NDQDIQLSEH FSVKVEQAKY 1401
VSMTIKGVTS ED SGKYSINI KNKYGGEKID VTVSVYKHGE KIPDMAPPQQ 1451
AKPKLIPASA SAAGQ

```

FIG. 1 C

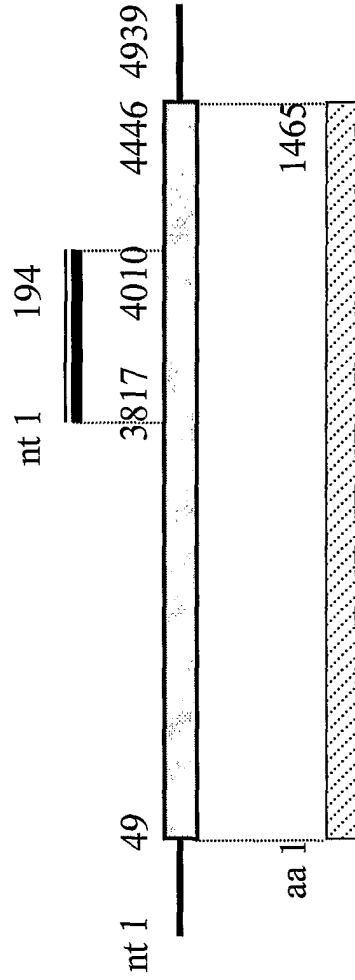

40399 (197 nt)

NM\_003970 (4939 nt)  
identical to X69089

NP\_003961 (1465 aa)  
identical to CAA48832

FIG. 1 D

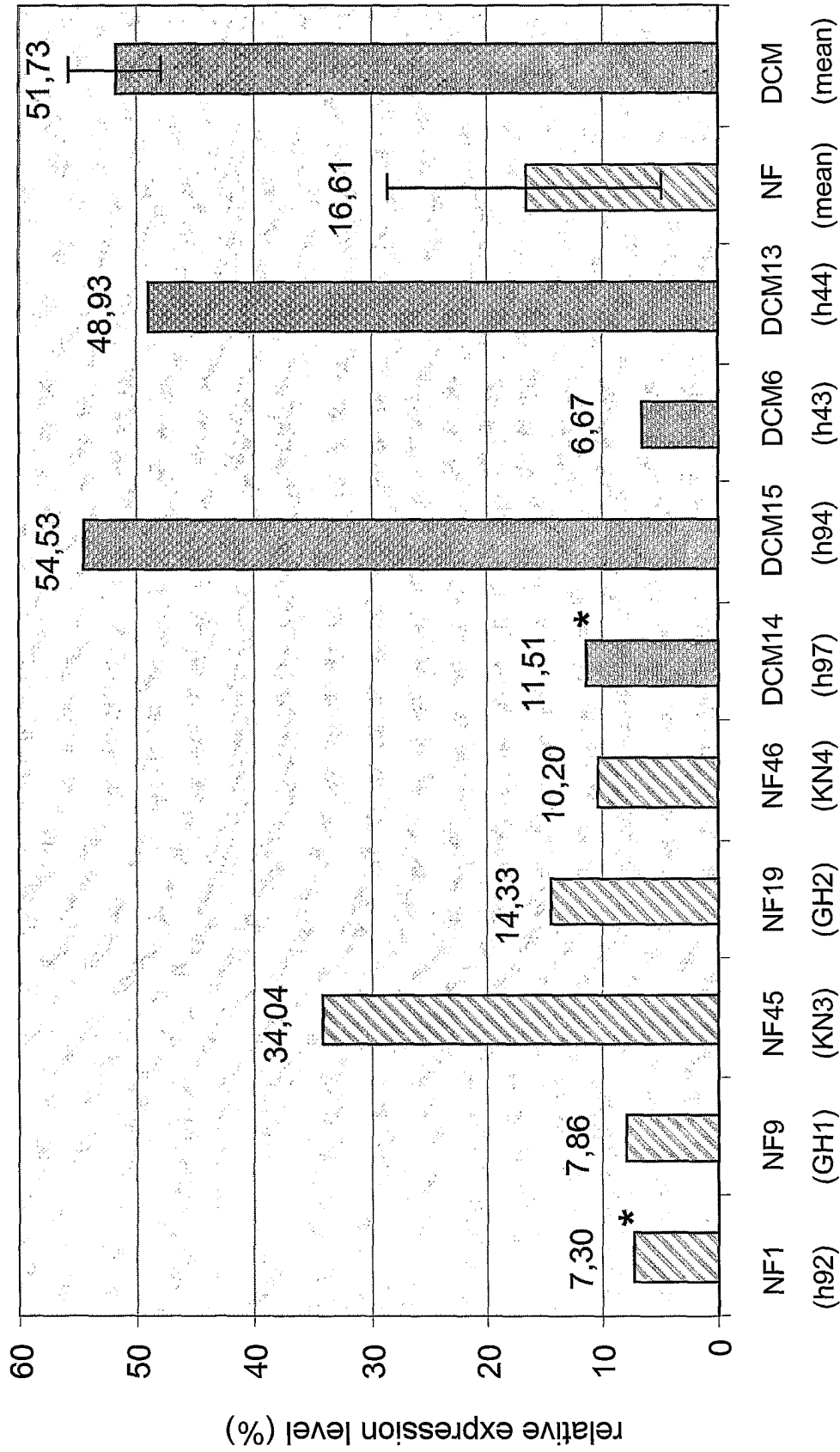

heart tissue sample

FIG. 1 E

Length: 403 nt  
>41441  
1 AAGAAGAAGA GATGTGCAAG GATAGGCCGA GTGAAGCTGA AGACACAAG AGTACAGGAA  
61 AAGTGCTATG GATCTTAATG ACAACAATAA TGTGATTGTG CAGAGTGCTG AAAAGGAGAA  
121 AAATGAAAAA ACTAACCAA CTAATGGTGC AGAAGTTTFA CAGGTTACTA AACTGATGA  
181 TGAGATGTGC CAGAAAATCA TAAAGAAAAT TTGAAATAAGA ATAATAATAA CAATTATGTA  
241 GCAGTCTCAT ATCTGAATAA TTGCAGGCAG AAGACATCTA TTTTAGAATT TCTTGATCTA  
301 TTACCCTTGT CGAGTGAAGC AAATGACACT GCAAATGAA ATGAAATTGA GAAGTTAGAA  
361 AATACATCTA GAATCTCAGA GTTACTTGGT AGATTTGAAT CTG

FIG. 2 A

Length: 2379 nt  
 >AW755252  
 1 cccaggatct gctctgaaac caggtctcta agtgaacatt tctcaggcat ggatgcattt  
 61 gagagtcaaa ttgttgagtc gaagatgaaa acctcttcat cacatagctc agaagctggc  
 121 aatctggct gtgacttcaa gcctgcccac ccaacctatg aggatgtcat tgctggacat  
 181 attttagata tctctgattc acctaaagaa gtaagaaaaa attttcaaaa gacgtggcaa  
 241 gagagtggaa gagtttttaa aggcctggga tatgcaaccg cagatgcttc tgcaacatga  
 301 gatgagaacc acctccaag aggaatctgc attataagt gaagctgctg ctccaagaca  
 361 aggaatatg tatactttgt caaaagacag ttatccaat ggagtccta gtggcagaca  
 421 agcagaattt tcataagtcc tgcttccgat gccaccattg caacagtaaa ctaagtttgg  
 481 gaaattatgc atcacttcat ggacaaatat actgtaaacc tcactttaaa caacttttca  
 541 aatccaaaagg aaattatgat gaaggttttg gacataagca gcataaagat agatggaact  
 601 gcaaaaacca aagcagatca gtggacttta tcctaatga agaaccfaat atgtgtaaaa  
 661 atattgcaga aacaccctt gtacctggag atcgtaatga acatttagat gctggtaaca  
 721 gtgaagggca aaggaatgat ttgagaaaaa taggggaaag gggaaaaatta aaagtcattt  
 781 ggcctccttc caaggagatc cctaagaaaa ccttaccctt tgaggaagag ctcaaaatga  
 841 gtaaacctaa gtggccacct gaaatgacaa cctgctatc ccctgaattt aaaagtgaat  
 901 ctctgctaga agatgtaga actccagaaa ataaaggaca aagacaagat cactttccat  
 961 ttttgcagcc ttatctacag tccaccctatg tttgtcagaa agaggatggt ataggaatca  
 1021 aagaaatgaa aatgcctgaa ggaagaaaaa atgaaaaagaa ggaaggaagg aagaatgtgc  
 1081 aagataggcc gagtgaagct gaaagacaaa agagtaacag gaaaaatgct atggatctta

FIG. 2 B/1

1141 atgacaacaa taatgtgatt gtgcagagtg ctgaaaagga gaaaaatgaa aaaactaacc  
 1201 aaactaatgg tgcagaagtt ttacaggtta ctaacactga tgatgagatg atgccagaaaa  
 1261 atcataaaga aatttgaat aagaataata ataacaatta thtagcagtc tcataatctga  
 1321 ataattgcag gcagaagaca tctatttag aatttcttga tctattacc tctgcagtg  
 1381 aagcaaatga cactgcaaat gaatatgaaa ttgagaagtt agaaaaataca tctagaatct  
 1441 cagagttact tggatatatt gaatctgaaa agacttattc gaggaatgta ctagcaatgg  
 1501 ctctgaagaa acagactgac agagcagctg ctggcagctc tgtcagcct gctccaaaaac  
 1561 caagcctcag cagagccctt atggtaaaagg ggggaagtc aatcatctct cctgatacaa  
 1621 atctcttaaa cattaaagga agccattcaa agagcaaaaa ttacacttt ttcttttcta  
 1681 acaccgtgaa aatcactgca tttccaaga aaatgagaa cattttcaat tgtgatttaa  
 1741 tagattctgt agatcaaat aaaaatatgc catgcttggg ttaagggaa tttggaaagg  
 1801 atgttaaac ttggcatgtt gaaacaacag aagctgcccg caataatgaa aacacaggtt  
 1861 ttgatgctct gagccatgaa tgtacagcta agcctttgtt tccagagtg gaggtgcagt  
 1921 cagaacaact cacggtggaa gagcagatta aaagaaacag gtgctacagt gacactgagt  
 1981 **aaa**aatatcta tggccactga cagtcacac ttaggcaactg agagatatatg atgttctgaa  
 2041 ataagathtt atgaatttg atacccttt gaggaacttg atgtaaacat ggtgttcaga  
 2101 aatctcgtgt ctatctcaat gggatatctc ttgtattaca cctgtcatt ttttcacaa  
 2161 tttatttaca tctactttg ttgaaactgg aatgaagaga tgaaacacta tggatatgtt  
 2221 ttccattcaa atggcacttt agcataattg tctgttttcc tgtaaacact catgggtgtg  
 2281 attttttatac tgctgctgct tgtcacaatt attataactt ctctgtaatt tcctctgaaa  
 2341 taaaattgaa tcacctgagg tgcaaaccaa aaaaaaaaa

FIG. 2 B/2

Length: 547 amino acids  
>41441pep

```

1  VKLLQDKEI  CILCQKTVYP  MECLVADKQN  FHKSCFRCHH  CNSKLSLGNY  ASLHGQIYCK
61  PHFKQLFKSK  GNYDEGFGHK  QHKDRWNCKN  QSRSVDFIPN  EEPNMCKNIA  ENTLVPGDRN
121  EHLDAGNSEG  QRNDLRKIGE  RGKLVWPP    SKEIPKKTLP  FEEELKMSKP  KWPEMTTLL
181  SPEFKSESLI  EDVRTPENKG  QRQDHFPLQ  PYLQSTHVCQ  KEDVIGIKEM  KMPEGRKDEK
241  KEGRKNVQDR  PSEADTKSN  RKSAMDNDN  NNVIQSAAEK  EKNEKTQTN  GAEVLQVTNT
301  DDEMMPENHK  ENLNKNNNN  YVAVSYLNC  RQKTSILEFL  DLLPLSSEAN  DTANEYEIEK
361  LENTSRISEL  LGIFESEKTY  SRNVLAMALK  KQTDRAAAGS  PVQPAPKPSL  SRGLMVKGGG
421  SIISPDTNLL  NIKGSHSKSK  NLHFFFSNTV  KITAFSKKNE  NIFNCDLIDS  VDQIKNMPCL
481  DLREFGKDVK  PWHVETTEAA  RNNENTGFDA  LSHECTAKPL  FPRVEVQSEQ  LTVEEQIKRN
541  RCYSDTE
    
```

FIG. 2 C

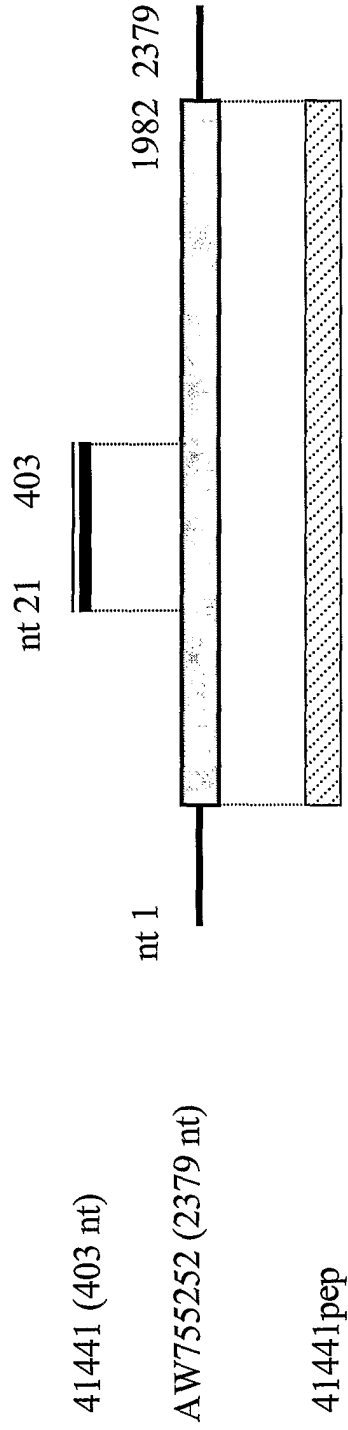
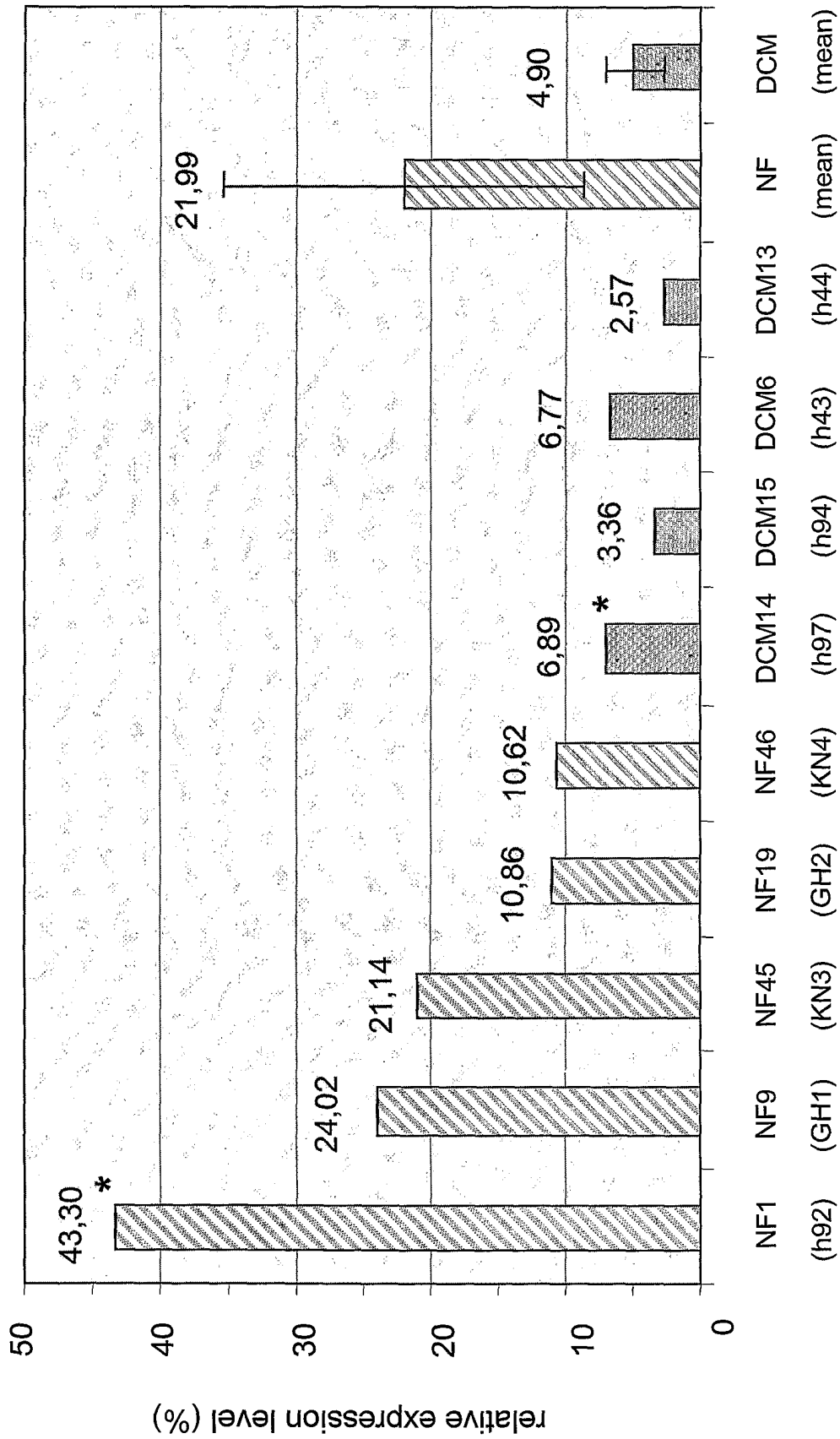

FIG. 2 D



heart tissue sample

FIG. 2 E

Length: 125 nt  
>52706  
1 ACAGCTTACA GAACGTGGG CCAATAAAC CTCCTTCTT TATAAATTAC CCAGCTTCAG  
61 ATATTCCCTT ATAGCGACAC AAATGGACTA AGGTGTCAAG ATCAATTGAT AGAGAAAGGC  
121 ATTGT

FIG. 3 A

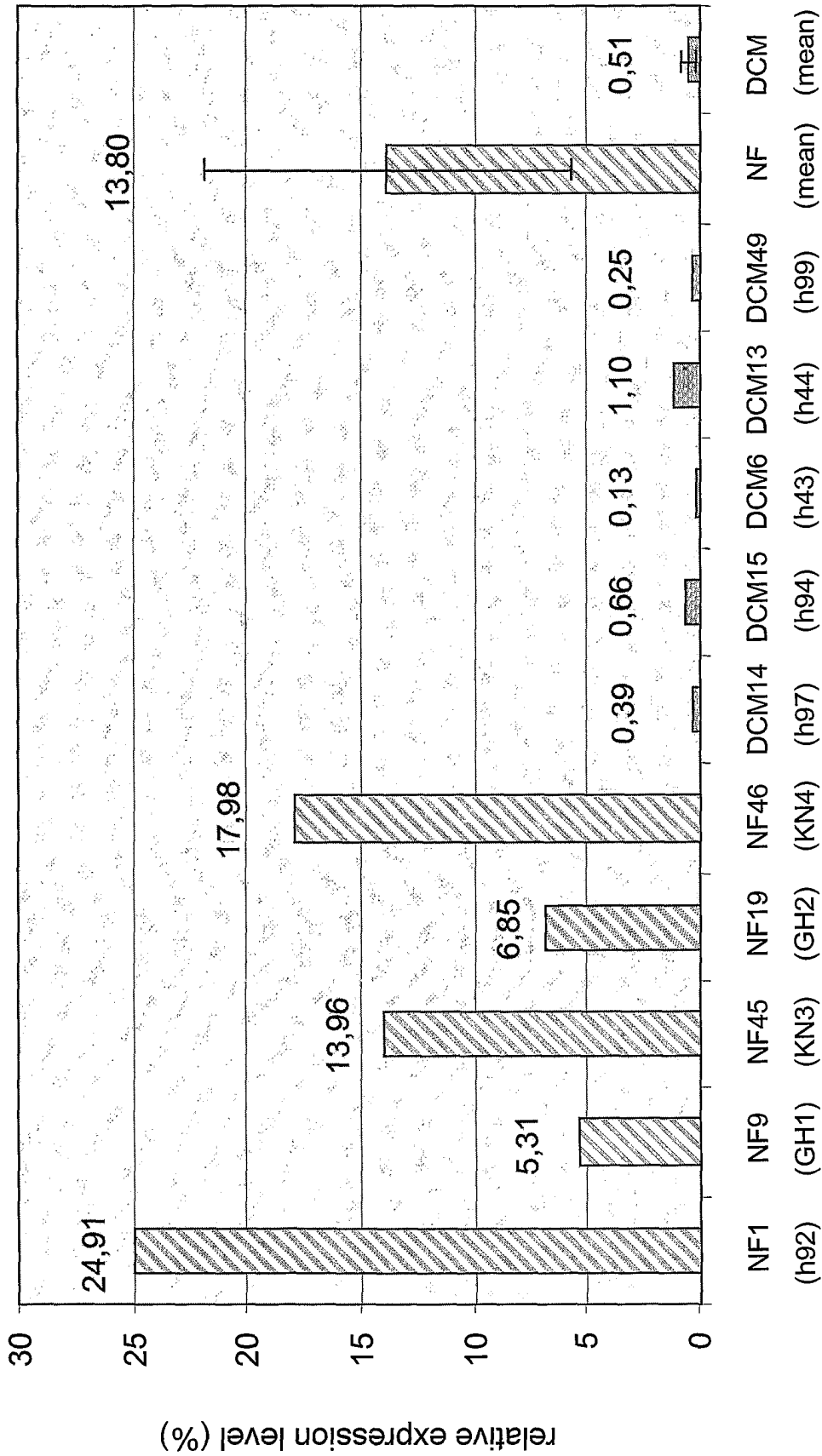

heart tissue sample

FIG. 3 B

Length: 508 nt  
>56461

```
1  GGCTGCATAG TCTTGGCGGA GGTGACCAA GCGCGTAAT GTCCGTAAGT CGCTCATCCG
61  TCCATGCCAG ATGGATTGTG GGAAGGTGA TTGGACAAA AATGCAAAA ACTGCTAAAAG
121 TGAGAGTGAC CAGGCTTGT TCCAGATGCC CTTACAGTGG GCATATTGTG CTTCTCAGAG
181 CCTACTTTGC TCCACGAGCA AAGCATGTGA AACATGAACT GGCTGAGATC GTTTTCAAAG
241 CTTTACCCTGT CATAGATCCA CCCAGCTAAG CAAAAATCTG GAAGAACTCA ATATCTCTTC
301 TTGGAAAAGT GTCCGTTGAG AGCGGGAGTG AAGAAGGATC TAAAGGGAAA AACTGACATG TTTATGTTAT
361 GTCCGTTGAG TCGGAAACCA CCCAGCTAAG CAAAAATCTG GAAGAACTCA ATATCTCTTC
421 AGCACAGTGA AGCGGGAGTG AAGAAGGATC TAAAGGGAAA AACTGACATG TTTATGTTAT
481 GGAAAAGAA ATTTTCTTAA GTTTCATC
```

FIG. 4 A

Length: 600 nt  
>AF077035

```
1 agtcttgcg gagtgacca aagccacgta atgtccgtag ttcgctcatc cgtccatgcc
61 agatggattg tggggaaggt gattgggaca aaaatgcaaa agactgctaa agtgagagtg
121 accaggcttg ttctggatcc ctatttatta aagtatttta ataagcggaa aacctacttt
181 gctcacgatg cccttcagca gtgcacagtt ggggatatg tgcttctcag agctttacct
241 gttccacgag caaagcatgt gaaacatgaa ctggctgaga tcgttttcaa agttggaaaa
301 gtcatagatc cagtacagg aaagccctgt gctggaacta cctacctgga ggtccggtg
361 agttcggaaa ccaccagct aagcaaaaat ctggaagaac tcaatatctc ttcagcacag
421 tgaagcggga gtggaagaag ggtctaaagg gaaaaactga catgtttatg ttatggaaaa
481 agaaaatttt ctaagtttca tcacaaactg tgtccagttt ctctgtggtg tttatgaaat
541 agctaaaagc aaatgaagta aagggcatac tatgggtttt cacaaaaaaa aaaaaaaaaa
```

FIG. 4 B

Length: 142 amino acids  
>56461pep  
1 LHSLGGDQS HMSVVRSSV HARWIVGKVI GTKMQKTAKV RVTRLVLDPY LLKYFNKRKT  
61 YFAHDALQQC TVGDIVLLRA LPVPRAKHKV HELAEIVFKV GKVIDPVTGK PCAGTTYLES  
121 PLSSETTQLS KNLEELNISS AQ

FIG. 4 C

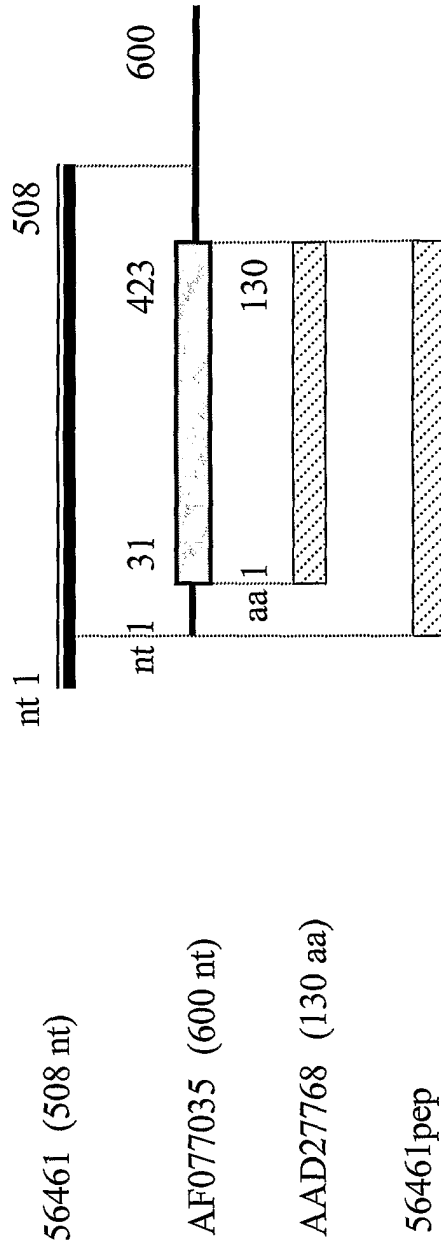
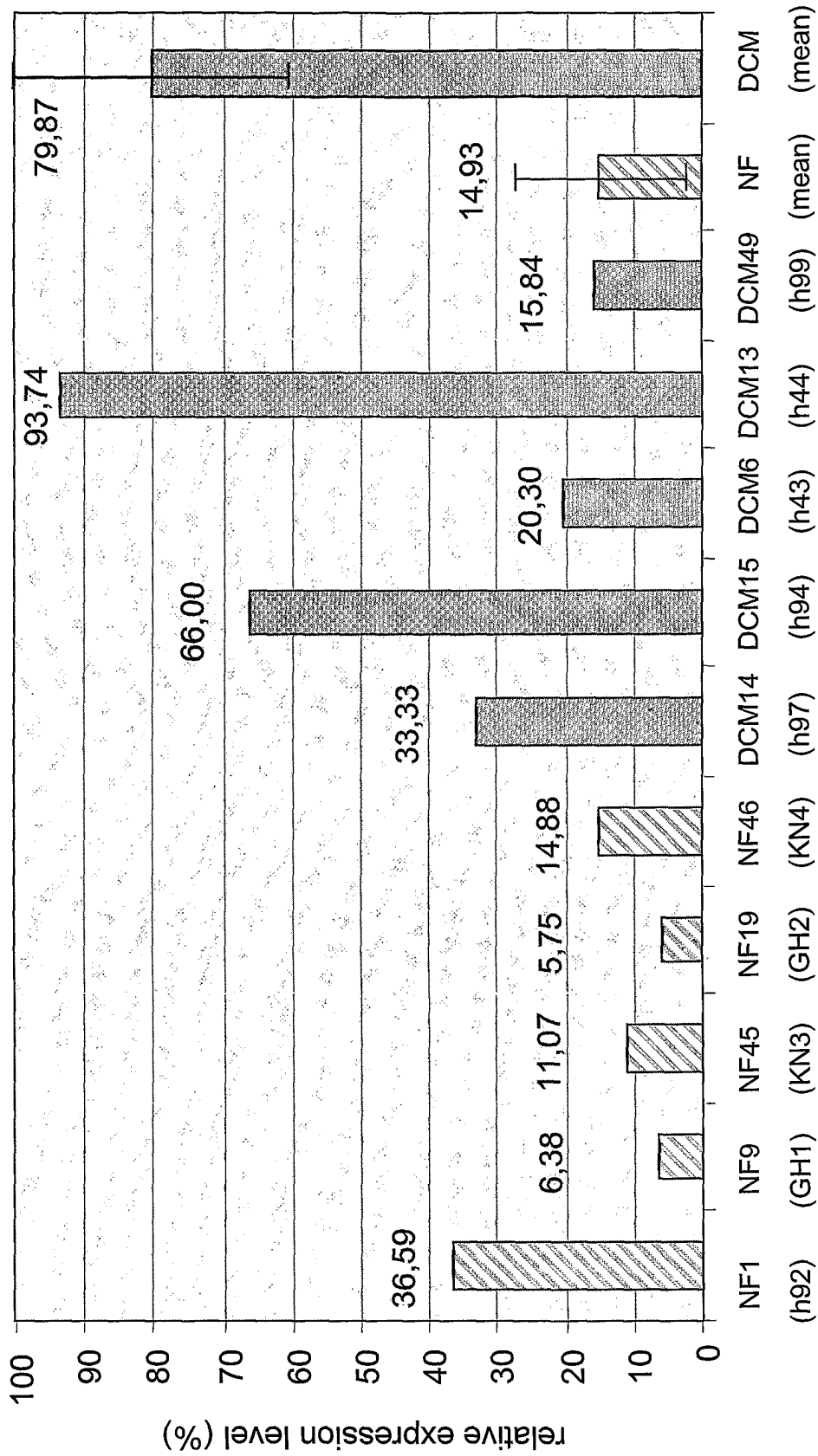

FIG. 4 D



heart tissue sample

FIG. 4 E

Length: 383 nt  
>611105  
1 ACCCCCTCTTC TGCAGACGCA GCGGGGTGAG GATCTCCTCG AAC TTGGGGT GCTTGCTCAG  
61 GTGCGCCAGC TTCACATGCA CGCCTCCACG CAGCCAGTG CCCAGGTGG ATGGGCAGGT  
121 GAGCACGTAG CCCAGGTGCT GGTCCACAT GAAGGGTGG CCAGCTTCT TAAAGATCTC  
181 CTCAATCTTC TGCAGCCCTA CGCAGAAGCG GCGGAAAACC TCCTTCATGT TGCCCCCCTT  
241 CTCCATGGAG ATGACCCGGA GGTGATCCTC CTCGTTACCC CACACCAGGA AGCTCTTGT  
301 GTCATTTGG CAGATGCCAC GGGCGTCGGG CCAGTCGCGG GCCATGCCCTG AGGCCAGCAG  
361 CAGCGGGGA CACGGCTTT GTC

FIG. 5 A

Length: 1562 nt  
>M14780

```

1  gtgggtcagc atgtcacctc caggatacag acagccccc ttcagcccag ccagccagg
61  tctccttaca cgcaccaccat gccattcggg aacaccaca acaagttcaa gctgaattac
121 aagcctgagg aggagtaccc cgacctcagc aaacataaca accacatggc caaggtactg
181 acccttgaac tctacaagaa gctgcgggac aaggagatcc catctggctt cactgtagac
241 gatgtcatcc agacaggagt ggacaaccca ggtcacccct tcatcatgac cgtgggctgc
301 gtggctggtg atgaggagtc ctacgaagtt tcaaggaaac tcttgacct catcatctcg
361 gatcgcacg ggggctaca accactgac aagcacaaga ctgacctcaa ccatgaaaac
421 ctcaagggtg gagacgacct ggaccccaac tacgtgctca gcagcccggg cgcactggc
481 cgcagcatca agggctacac gttgccccca cactgctccc gtggcgagcg ccgggcggtg
541 gagaagctct ctgtggaagc tctcaacagc ctgacgggcg agttcaaagg gaagtactac
601 cctctgaaga gcatgacgga gaaggagcag cagcagctca tcgatgacca cttccagttc
661 gacaagcccg tgtccccgct gctgctggcc tcaggcatgg cccgccactg gcccgacgcc
721 cctggcatct ggcaacaatga caacaagagc ttccctgggtg ggggtgaacga ggaggatcac
781 ctccgggtca tctccatgga gaaggggggc aacatgaagg aggttttccg ccgcttctgc
841 gtagggctgc agaagattga ggagatcttt aagaaagctg gccaccctt catgtggaac
901 cagcacctgg gctacgtgct cacctgcca tccaacctgg gcaactgggct gcgtggaggc
961 gtgcatgtga agctggcgca cctgagcaag caccacaagt tcgaggagat cctcaccgc
1021 ctgcgtctgc agaagagggg tacaggtgcg gtggacacag ctgccgtggg ctcagtattt
1081 gacgtgtcca acgctgatcg gctgggctcg tccgaagtag aacaggtgca gctgggtggtg

```

FIG. 5 B/1

1141 gatggtgtga agctcatggt ggaatggag aagaagtgg agaaaggcca gtccatcgac  
1201 gacatgatcc ccgccagaa **gtagg**gcct gccacctgc caccgactgc tggaaaccca  
1261 gccagtggga gggcctggcc caccagatc ctgctccctc actcctcgc ccgccccctg  
1321 tcccagagtc cacctggggg ctctctccac ccttctcaga gttccagttt caaccagagt  
1381 tccaaccaat gggctccatc ctctggattc tggccaatga aatatctccc tggcagggtc  
1441 ctcttctttt cccagagctc ctccccacc aggagctcta gttaatggag agctcccagc  
1501 acactcggac gcttgtgctt ttgtctccac gcaaacggat aaataaaagc attggtggcc  
1561 tt

**FIG. 5 B/2**

Length: 381 amino acids  
>AAA52025

```

1  MPFGNTHNKF  KLNYPKEEY  PDLSKHNNHM  AKVLTLELYK  KLRDKEIPSG  FTVDDVIQTG
61  VDNPGHPFIM  TVGCVAGDEE  SYEVFKELFD  PIISDRHGGY  KPTDKHKTDL  NHENLKGDD
121  LDPNYVLSSP  VRTGRSIKGY  TLPFHCSRGE  RRAVEKLSVE  ALNSLTGEFK  GKYYPLKSMT
181  EKEQQQLIDD  HFQFDKPVSP  LLLASGMARH  WPDAPGIWHN  DNKSFLVWVN  EEDHLRVISM
241  EKGGMKEVF  RRFVGLQKI  EEIFKKAGHP  FMWNQHLGYV  LTCPSNLGTG  LRGVHVKLA
301  HLSKHPKFE  ILLRLRLQKR  GTGAVDTAAV  GSVFDVSNAD  RIGSSEVEQV  QLVVDGVKLM
361  VEMKKLEKG  QSIDDMIPAQ  K

```

FIG. 5 C

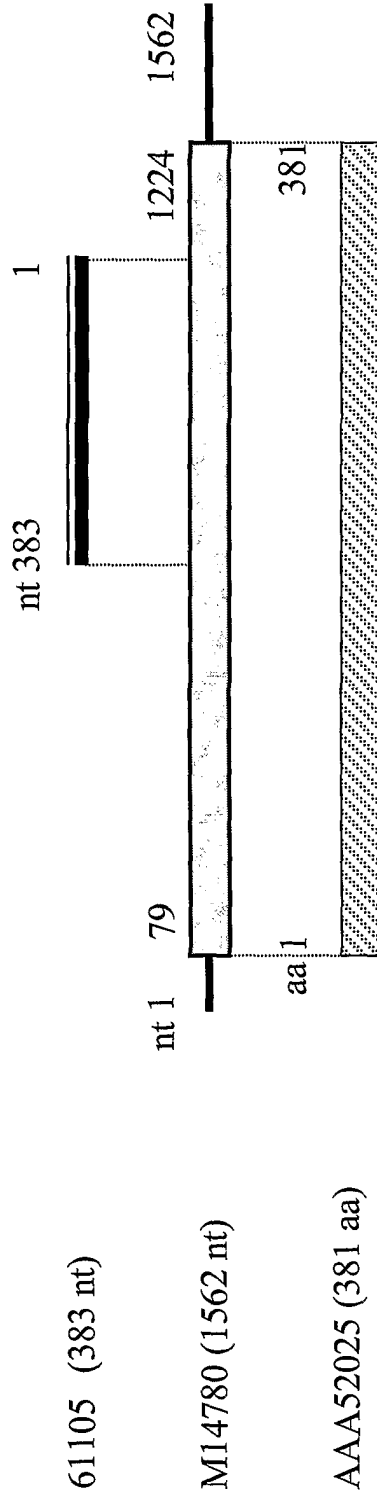
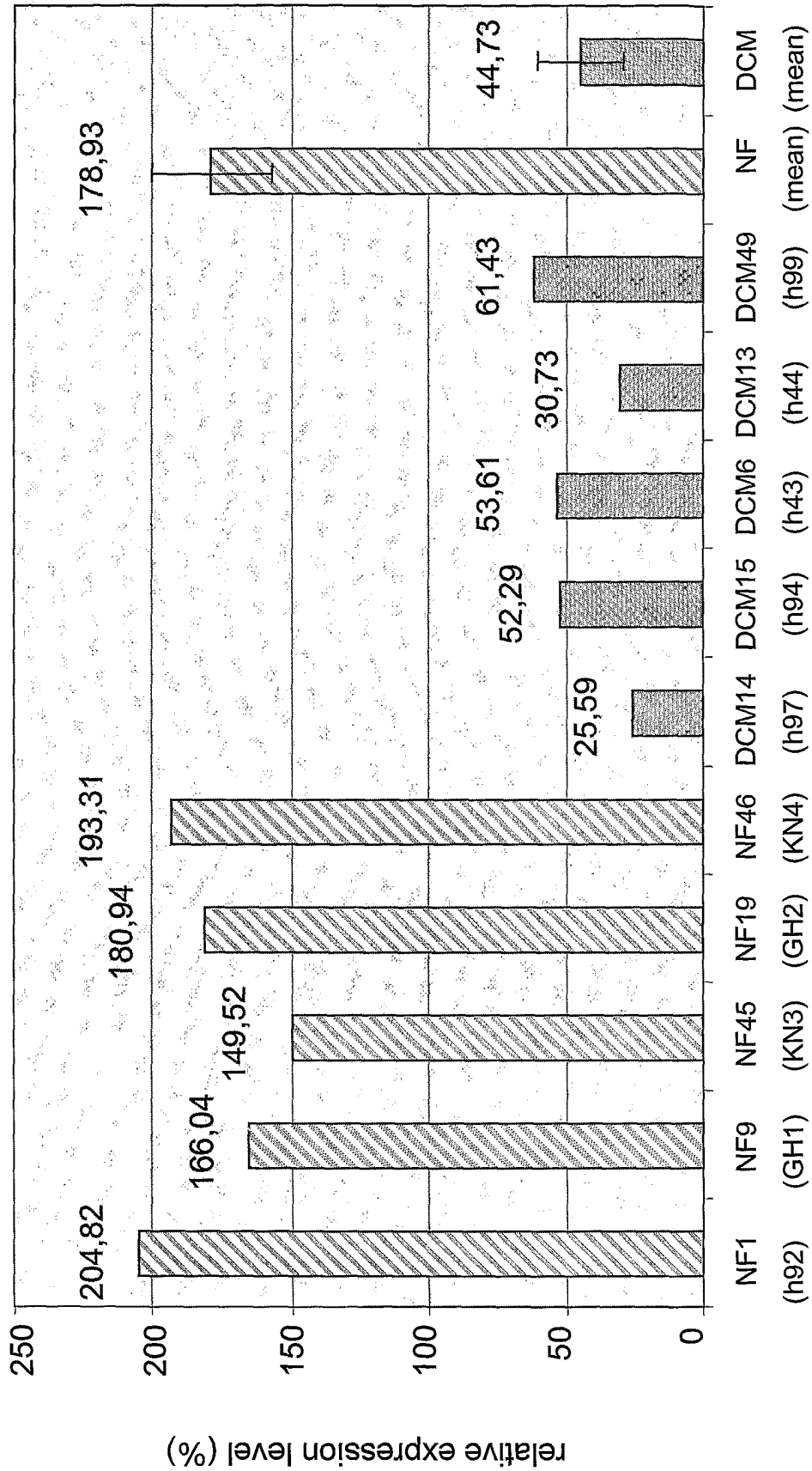

FIG. 5 D



heart tissue sample

FIG. 5 E

Length: 403 nt  
>61166

```
1  ACTTTGAGAA  GTTACTTTCT  AATTACGTCA  TGAGAACACA  ACTTGTAAAT  AGCAACACTT
61  CTGTCAGTCT  AGATCACTTC  TTCTGCAGAG  AGCTTTTCAA  CCAAGTTGGC  ATCAACCAGC
121  ACAATAAAGT  TTTCACTGTT  TTACCTGTTT  CCTGTAATG  GTGTAATCAG  TGAAGAATAA
181  GGCATTTTCC  ATCCTAAATA  ATACGGTGAA  ACACGTGCTA  AAAATTACTT  AGATTTAACA
241  GAATTGCAAT  TAGGTTTTGA  CAATGTATTT  ACTTCAAGAC  AATGTATTTT  ATCAGGAAAA
301  AATATCTTGA  AAGAAAGATC  TCTGAAATTA  TTTTTTCATTT  GATACGCCCTT  TTCTGTGACA
361  AAATTTGGG  GTGAAATGGA  TGATGTTTAC  TGATTGATTT  AGT
```

FIG. 6 A

Length: 4828 nt  
>61166contig

```
1  ttttccaagt  ggaagttaa  ttgtctttat  tttcttata  cagattcaga  gaagtaaaaa
61  ccagtaacca  actccaggta  aaatggtttg  atctgatcga  tttggctgca  tactttcggg
121 acgtataaca  ttctaactt  aaaatagaaa  tttttatatt  acaaaaacgta  gaagtaaaa
181 tttaaaaagt  taaagtacta  gcacatatat  gtgttaggaa  aatggtctct  gtcaattggc
241 cattttcca  attaaattaa  cctacgattt  cctttttta  acagcttatt  tttttcataa
301 aagtgtact  ttgagaagtt  actttctaata  tacgtcatga  gaacacaact  tgtaatttagc
361 aacacttctg  tcagtctaga  tcacttcttc  tgcagagagc  ttttcaacca  agttggcatc
421 aaccagcaca  ataaagtttt  cactgtttta  cctgtttcct  gtatatggtg  taatcagtgga
481 aagaaatggc  atttcacatc  ctaaataata  cggtgaaaca  ctgtctaaaa  attactttaga
541 tttaaacagaa  ttgcaattag  gttttgacaa  tgtatttact  tcaagacaat  gtatttttacc
601 agaaaaaaat  atcttgaag  aaagatctct  gaaattattt  ttcatttgat  acgccttttc
661 tgtgacaaaa  ttttggggtg  aaatgatgat  gtttgctgat  tgatttagta  ctaaaaaagac
721 tagtactaag  aagactaaag  acagttatct  tataataaga  aatatagtat  aaatagcacc
781 ttatcaagaa  ttctgcaggg  gttttaacac  ttacaataat  aggaaatagc  cattaanaag
841 ttgctctaac  tttagatttc  taactttagt  gttctttaac  aaaggccata  ttttgtggcc
901 ttaaaaaaaa  aaaattatat  ctggctttat  ctattagtaa  acacaaaagg  tccataattt
961 attctgaaaa  aatatttatt  atattcattc  ataatgttc  taactaattt  aactaaaaaa
1021 atcttctagt  attttctgat  gccacaagct  tactagaaaa  ttacttctaa  aaattggtaa
1081 tataaatcat  caatgattta  cctactttta  aaaagagggg  tatctgtttc  tcttacattt
```

FIG 6 B/1

1141 aataacctga aatgagct ataaaaatat ttttaaaaaa tacagtaaca ctgctgagtt  
1201 ttgttaggtc cttgtttttt ttaatttttt atttatttat ttatttttag caagaatgta  
1261 caattctttt tgcaattttt tgctaacaaa agacaaaaag aaatagtgct cccttcaatt  
1321 tagtagcaat aaaatcatct atcttcatct ctctcagagg gcttagggag agtgaaggga  
1381 attagaggaa cataaacccat gggtccttca ggtaaaaaaa gtcatttcat agtgatggag  
1441 gcaacagcag gctacgctct tgtctgcctg tacgctcagc atcagcatgc cctgcccctc  
1501 ctctcccac ataagggtga ccaaagcctt ctttcttctt acaacagagt cttccgggat  
1561 aaagggtggca acagaaaatt gttgctttgt ccttttgggg catctcttgc atctcctgct  
1621 tgttttgctt ttgggggtact ataacttctc tctttccatt tcacaactag tctcctttcc  
1681 acgatatctc ataacttctc tacttcatct ctgacctttt cacttgcctt ctttccaaca  
1741 tgatccaatg tactctgtac atgtatatc cggtagatca aaaggaatct tatttaagat  
1801 cccaacaaa taagtccccc atggaatgt aaagtatctt ctcagagact caaattatta  
1861 aagtcttca aaaaagatta aattcataga ttataataa tattagtca aaatattaa  
1921 cagttgagga cttcattggc aatgcaggca gactgcatgc cagttgaaca tgatgctctc  
1981 tcagtcctta aaagctaatt aaaaatggtt ttggttacat aagaggattt gaatacatat  
2041 ttcatgcctt ttataccaa ctgtagcaaa caggattagg ataataact taggaatcaa  
2101 ttttactgaa ttcagaaaca tttatctcca ccatacacc tcaaagggca tttttttta  
2161 catgtcagtc agagatctgc ttcatccttc agtttcatag atagaattat ttaaacact  
2221 tgaatctag gaagcaaac tgacaaggct tcagaattta aaagcaaca gctcactgtg  
2281 tgtgggtgtc tatcaggttg aaatctatgt tgtcctgatg ttttcagagt ttttcaaaa  
2341 gacaaaaata cagttgccac tgatttatca aaaacatttg gctgcctttt gtcatcagct

FIG. 6 B/2

2401 acaaaattac agtgctttat aaaataaaca tcaaggccgg gtgcggtggc tcacgccagt  
 2461 aatcccagca ctttggaagg ccgagatggg tggatcacct gagatcagga gtttgagaac  
 2521 agcctgacca ttatggtgaa acccgtctc tactcaaat acaaaaaatt agccggacgt  
 2581 ggtggcaggc gcctgtaac ccagctactc gggaggctaa ggcaggagaa tcgcttgaac  
 2641 ccagaaggca gaggttgca gaggccgaga ttgtgccatt gcattccagc ctggacaaca  
 2701 agagcaaaac tcgatctcaa aaacaacaa acaacatcaa gaaaaaaaa aaaccatcag  
 2761 attctaagct gcaatthttt aaatcccag ttgtaatat tcaaaaaactt ttgtttgaat  
 2821 aaatgctca taattagta ccaactggc tcttcacaa gatctgtagt gtaagaactg  
 2881 tgactaatgc tgctgctgct actttcacgc tggaggact aagttgtcta gatgctctgc  
 2941 agtaaaataa cgaagataa gctacaatag gactgtgtgc ctttataaat acagactaat  
 3001 aagagccatc agagccagca tggattcaaa attacattgt attccataca gtagaattht  
 3061 actatccata caatgattht taaagctcaa gttaaatagt ttttaaagca tttggacta  
 3121 ctgtcatcaa tacagthttt gaaactgtaa atcaggtcga attttgtgca catttcctgg  
 3181 accaagatgc cctcagaagt aactgcctgt ggtcagcttt ttatggtta aaatcaattg  
 3241 gtgtataaat ttcaattaac acccataaag cttagccatg gggcagcaga gaagaaagag  
 3301 aaaagtattc tgcataatca atcctgcaga cacaattctg tataatctgt cacaagaacg  
 3361 caggcttgca gaaaatgaaa atagaatat tatttatgtt taacttaagt tactctcaat  
 3421 caaaaccagg caatgatata actggcaaca taaaaggag ggagcacgag tcatggaggc  
 3481 ggggaagtgt gcacctgcag acttgctctg ctccatcact tttccaaga ggcccaggaa  
 3541 atgtaaggtc atggctacat ccaagttaca atggtagtga **tt**acagccag gttagaagg  
 3601 gctcacttht gttcagagca gactctacat cattgaagag ggggatcagg tcttcagatt

FIG. 6 B/3

3661 ccaagttcc taagtcaacg tttgttcctg gaagacagtc aaggaatca gggaaacggg  
 3721 tctgttggg attgatgttc atgggtgttt gtccctgcgtt ttctcctgta tccatctcat  
 3781 ccacattgct gaggaagtcc tccggagtgt tggggacact gtagaccct aaccacaggc  
 3841 cactgtcagt gctctgctcc ctgcaatgat atggccctcc attgagaaa ggatctgagc  
 3901 tattattagt gatggatctc atgtctgggg tcatcgtggg tgggttgaca gcagcctgaa  
 3961 ctggggcaag agtctcagct tccatgggga gctgtcgaca gagggcagct tcctgcctca  
 4021 tgagctcctc ttggcgcat tgaatccttt ctctctacat ctggattctc tgaagccgca  
 4081 gttctgctg ctgctgctgc tgagtggta gcgcatggg cactcatg agccctgcgg  
 4141 gtgggttctg agtgggtgg ttctgctggc tcagggact gggggccatc tctgctggt  
 4201 gttggtgatt catcacgaga tttggctggg atactgccat ggacctctga ggcactggtg  
 4261 tggaaactgac ggcaggtgg aggttcatat gattcagagg ctgattcatc gccttcctag  
 4321 ggtcttgcca tgtggtgatt tttctatgt gattgagaa gtacctctgg ccagtggcgg  
 4381 tgaaggtcat ctccagccc gggggcagtg gcagctctc ggtcacgtcg taggactgct  
 4441 ggcggagggtg cgcgtgctgc tgcgcggggc taccgcagc acccgccgg gtgccagct  
 4501 gcagggacgc gggcgacgag tgcgagcggg catgctgggc accccagcc agtcgaggcc  
 4561 ccgggtggcc gcccgacgag tcggtgctgg actggcgcca gtgcgagccc gaatcaggct  
 4621 ccttaaagaa agactccggc aggatcttct tccgccacga gctaggcttc ggattcatga  
 4681 cagagttgaa gagggcttcg aggtctgtgt ctaggctctg cgtgacgtgg atcacttgct  
 4741 gcccagggcg cgggagcggg gggggcgccg aggccggatt **catctctg** gcgggcagcg  
 4801 aagctgagcc tgagcgcgcg gcggccgc

FIG. 6 B/4

Length: 398 amino acids  
>61166pep

1 MNPASAPPP L PPPGQQVIHV TQDLTDLEA LFN<sup>S</sup>VMNPKP SSWRKKILPE SFFKEPDSGS  
61 HSRQSSITDSS GGHPGPRLAG GAQHVRSHSS PASLQIGTGA GAAGSPAQQH AHLRQQSYDV  
121 TDELPLPPGW EMTFTATGQR YFLNHIKIT TWQDPRKAMN QPLNHNMLHP AVSSTPVPQR  
181 SMAVSQPNLV MNHQHQQMA PSTLSQQNHP TQNPAGLMS MPNALT<sup>T</sup>TQQQ QQQKLR<sup>L</sup>QRI  
241 QMERERIRMR QEELMRQEAA LCRQLPMEAE TLAPVQAAVN PPTMT<sup>T</sup>PD<sup>M</sup>RS ITNNSSDPFL  
301 NGGPYHSREQ STDSGLGLGC YSVPTTPEDF LSNVDEMDTG ENAGQ<sup>T</sup>PMNI NPQQTRFPDF  
361 LDCLPGTNVD LGTLESEDLI PLFNDVESAL NKSEPFLL

FIG. 6 C



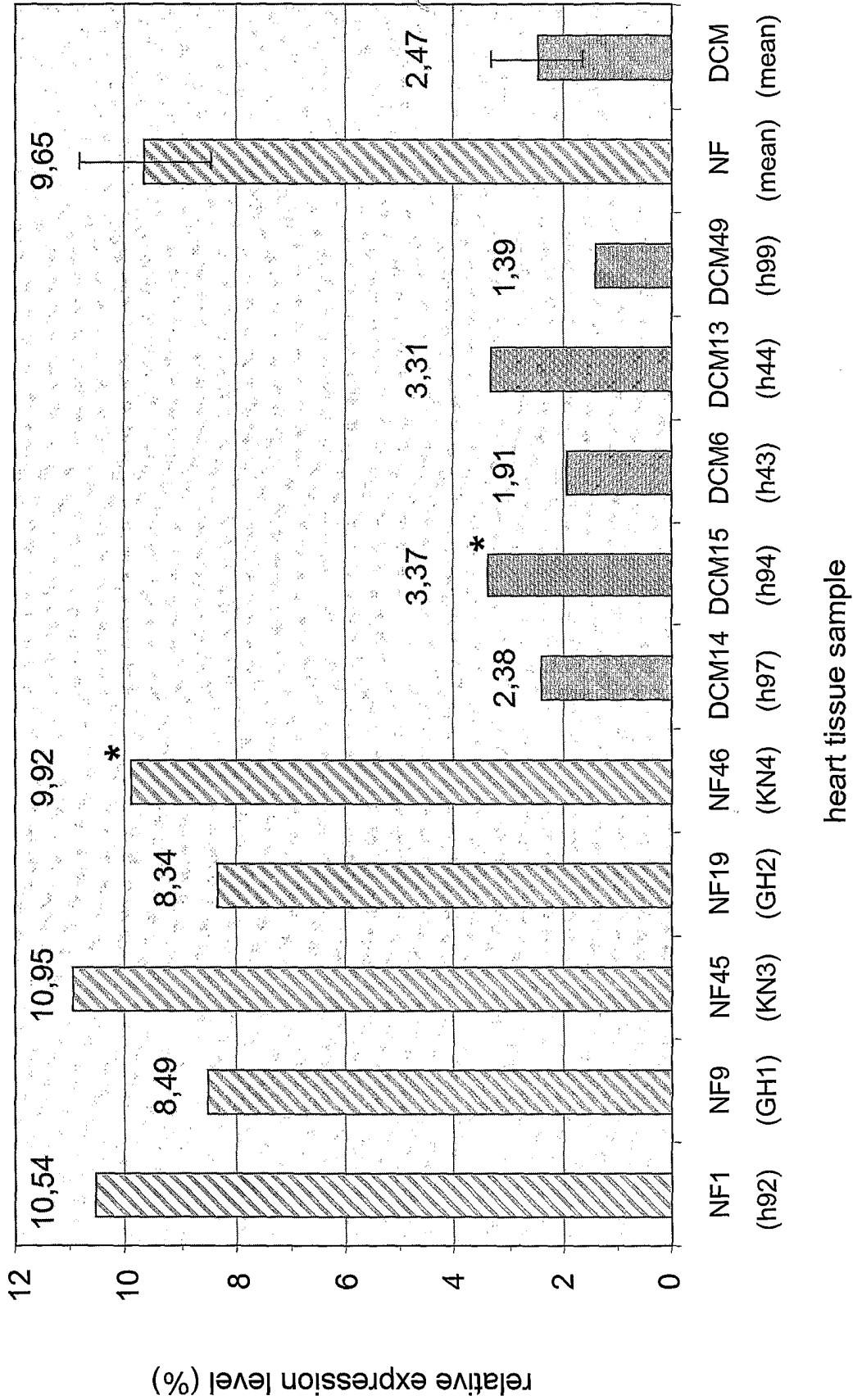

FIG. 6 E

Length: 168 nt  
>61244  
1 ACAGTTCCGG GAGGAACAAG ACCTTCCTCT GCTATGTGGT TGAAGCACAG GGCAAGGGG  
61 GCCAAGTGCA GGCATCTCGG GGATACCTAG AGGATGAGCA TGCGGCTGCC CATGCAGAGG  
121 AAGCTTTCTT CAACACCATC CTGCCAGCCT TCGACCCAGC CCTGCGGT

FIG 7 A

Length: 1164 nt  
 >AF161698

```

1  gaattccggc  gccctctctc  ctctccctca  gtgactcctg  agccacagcc  cctccatggc
61  ccagaaggaa  gaggctgctg  tggccactga  ggctgcctcc  cagaatgggg  aggatctgga
121  gaacctggac  gacctgaga  agctgaaaga  gctgattgag  ctgccgccct  ttgagattgt
181  cacaggagaa  cggctgcctg  ccaactcttt  taaattccag  ttccggaatg  tggagtacag
241  ttccgggagg  aacaagacct  tcctctgcta  tgtggtgaa  gcacaggga  aggggggcca
301  agtgcaggca  tctcggggat  acctagagga  tgagcatgcg  gctgcccctg  cagaggaaagc
361  tttcttcaac  accatcctgc  cagccttoga  ccagccctg  cggtaacaatg  tcacctggtc
421  tgtgtcctcc  agcccctgtg  cagcgtgtgc  tgaccgcatt  atcaaaaacc  ttagcaagac
481  caagaacctg  cgtctgctca  ttctggtggg  tcgactcttc  atgtgggagg  agccggagat
541  ccaggctgct  ctgaagaagc  tgaaggaggc  tggctgtaaa  ctgcgcatca  tgaagccccca
601  ggacttcgaa  tatgtctggc  agaatttgt  ggagcaagaa  gagggtgaa  ccaaggcctt
661  tcagccctgg  gaggacattc  aggagaactt  cctatactac  gaggagaagt  tggcagacat
721  cctgaagtag  ggcaactggg  cttgcctca  cgtattcctg  ctgccaccaa  gagacagcaa
781  tgacatgtac  agccatctgg  gacatgcctg  tcttcctaat  accatttggg  gctggacaac
841  atttgacacc  aaccaatcat  actggacaag  gcccttagag  gacttgaaat  atacttctca
901  tgctgtagtt  tatttaggct  gtgactctct  ctctaagtct  gctctcggga  aggacgaaag
961  tgacctgcaa  ggagagaaat  gcaaccatac  atgggctcca  gtcaactatg  ggactgaagg
1021  tcctaattgc  tcacccaagg  gggctgctta  acacaaaacag  cctcagacct  gaggtttaga
1081  tttctgaaat  atgcatttta  tgttaagtgt  ggtatttttt  taaaaaaga  aaaacagcaa
1141  cattaataaa  agaagtgggtg  tggc
  
```

FIG. 7 B

Length: 224 amino acids  
>AAD45360  
1 MAQKEEA AVA TEAASQNGED LENLDDPEKL KELIELPPFE IVTGERLPAN FFKFQFRNVE  
61 YSSGRNKTFI CYVVEAQKG GQVQASRGYL EDEHAAAHAE EAFFNTILPA FDPALRYNVT  
121 WYVSSSPCAA CADRIIKTIS KTKNLRLLIL VGRIFMWEEP EIQAAALKLK EAGCKLRIMK  
181 PQDFEYVWQN FVEQEEGESK AFQPWEDIQE NFLYYEEKLA DILK

FIG. 7 C

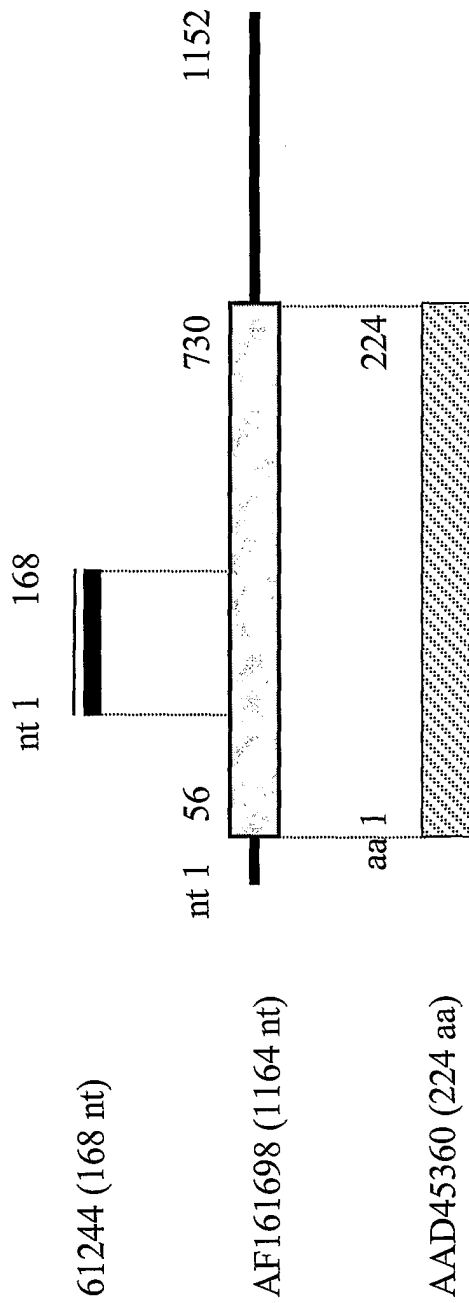
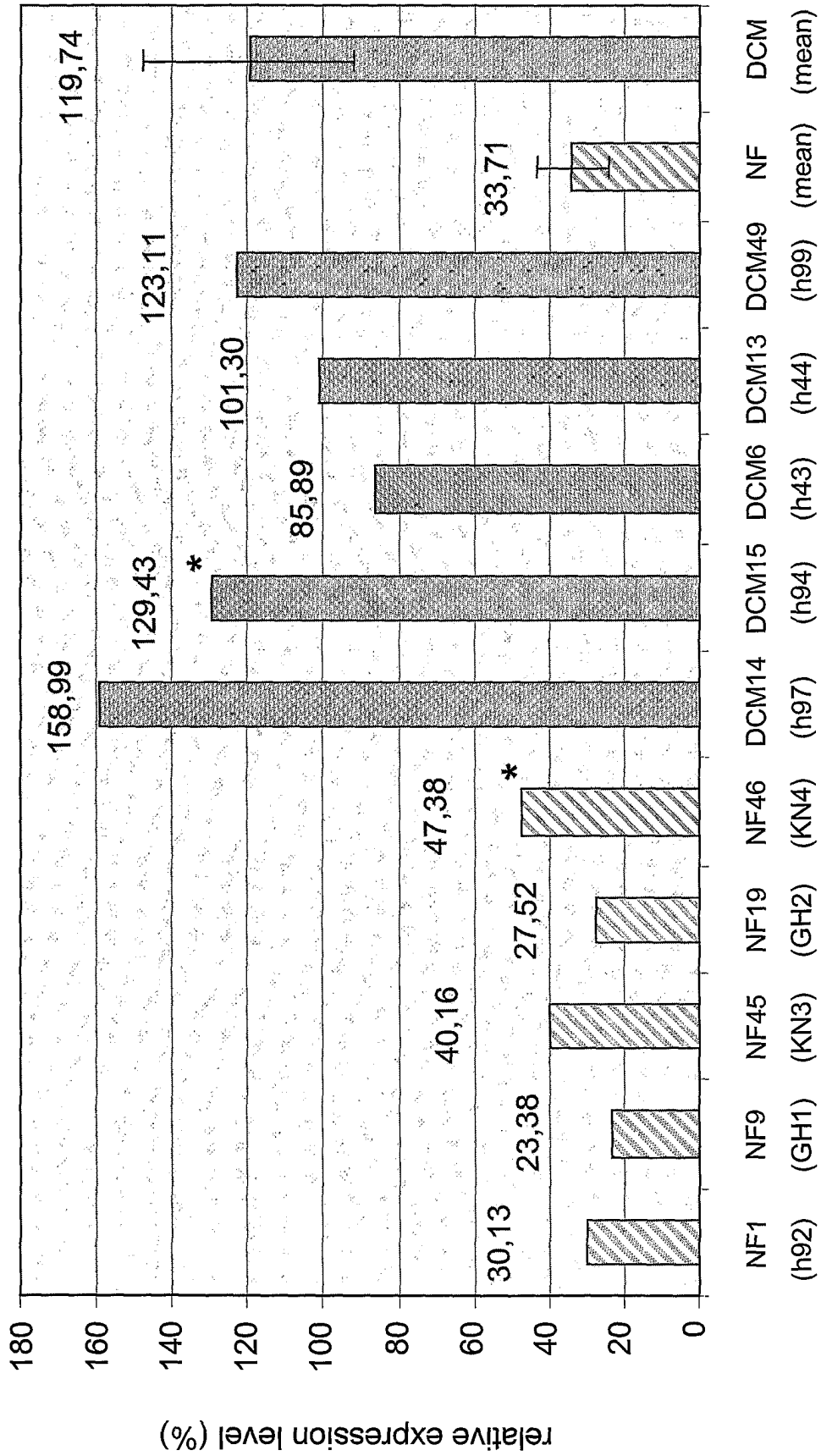

FIG. 7 D



heart tissue sample

FIG. 7 E

Length: 334 nt  
>65330  
1 ACTATCAATC TCCCTGGGAA CAAGCCATTA GCAATGATCC GGAGCTTTTA GAGGCTTTAT  
61 ATCCATAAAT TTTCAAGCCT GAAGGAAAGG CAGAACTGCC TGATTACAGG AGCTTTAACA  
121 GGGTTGCCAC ACCATTGGA GGTTTTGAAA AAGCATCAAG AATGGTTAAA TTTAAAGTTC  
181 CAGATTTTGA GCTACTATTG CTAACAGATC CCAGGTTTAT GTCCTTTGTG AATCCCCCTT  
241 CTGGCAGACG GTCCTTTAAAT AGGACTCCCTA AGGATGGAT ATCTGAGAAT ATTCCCTATAG  
301 TGATAACAAC CGAACCTACA GATGATACCA CTGT

FIG. 8 A

Length: 1590 nt  
 >65330contig  
 1 gtcagagtag ggaccatgct gtcccaggtt caaggataaa aaccatcagg cccaagtgcc  
 61 atccatagtc catctccaga gtcttcctcc acaaaactggg attcatcccc gctgaaaaaag  
 121 cacaatctaa cagcaagggg acaaaaaaac **catg**ctatca cataatacta tgatgaagca  
 181 gagaaaacag caagcaacag ccatcatgaa ggaagtccat ggaaatgatg ttgatggcat  
 241 ggacctgggc aaaaaggtca gcatccccag agacatcatg ttggaagaat tatcccatct  
 301 cagtaaccgt ggtgccaggc tattaagat gcgtcaaaga agatctgaca aatacacatt  
 361 tgaaaatttc cagtatcaat ctagagcaca aataaatcac agtattgcta tgcagaatgg  
 421 gaaagtggat ggaagtaact tggagggtgg ttcgcagcaa gcccccttga ctccctcccaa  
 481 caccocagat ccacgaagcc ctccaatcc agacaacatt gctccaggat attctggacc  
 541 actgaaggaa attcctcctg aaaaattcaa caccacagct gtccctaagt actatcaatc  
 601 tccctgggaa caagccatta gcaatgatcc ggagcttta gaggtttat atcctaaact  
 661 tttcaagcct gaaggaaaagg cagaactgcc tgattacagg agctttaaca gggttgccac  
 721 accatttggg ggttttgaaa aagcatcaag aatggttaaa tttaaagttc cagattttga  
 781 gctactattg ctaacagatc ccaggtttat gtcctttgtc aatccccctt ctggcagacg  
 841 gtcctttaat aggactccta agggatggat atctgagaat atcctatag tgataacaac  
 901 cgaacctaca gatgatacca ctgtaccaga atcagaagac ctat**g**aaaag aaagtgtat  
 961 gtgccacata aaactctgaa tataaaagt gctgttctac tattttaact actggcaaaag  
 1021 ccaattgcat ttttcattag tagcaacaat agcaatttag tgattttcct tttctgacat  
 1081 tcaatttcaa tctcagatca aatactaata aacaattaga aatcttactt taaaaaactt

FIG. 8 B/1

1141 ataactcact tgtcttcatt cataattttg tttcacctg gtttaaagaa tccagatatt  
1201 ttactgcaaa agttcagatg gaaaagtaat tgacagyttc acctttgtct cattttatat  
1261 gatttattac agtgtaagtt tttcaagtgg aatctagaat caaatatagag ggagagatat  
1321 gaagacctat tcagagtffc atctgggat gaaagctatg gaagatgatg tacaatgtt  
1381 attgatggag aaaatggttg gtgtgcctt tctggtgacc atgagaaata tatgtcttga  
1441 tgaagtcttt tcattagtca ctcttagaat tctaaagtgc tttgcacttt tncaatatgt  
1501 tttgaatcat taggtaattt attctgggnt gatattctcc aaaattcaat tcagttatta  
1561 tattcattta ggcattaagt caaggngact

**FIG. 8 B/2**

Length: 264 amino acids  
>AAF63623

1	MLSHNTMMKQ	RKQQTAIMK	EVHGNDVDGM	DLGKKVSI PR	DIMLEELSHL	SNRGARLFKM
61	RQRRSDKYTF	ENFYQSR AQ	INHSIAMQNG	KVDGSNLEGG	SQQAPLTFPN	TPDPRSPPNP
121	DNIAPGYSGP	LKEIPPEKFN	TTAVPKYYQS	PWEQAISNDP	ELLEALYPKL	FKPEGKAE L P
181	DYRSFN RVAT	PFGGFEKASR	MVKFKVPDFE	LLLLTDPRFM	SFVNPLSGRR	SFNRTPKGWI
241	SENIPIVIT T	EPTDDTTVPE	SEDL			

FIG. 8 C

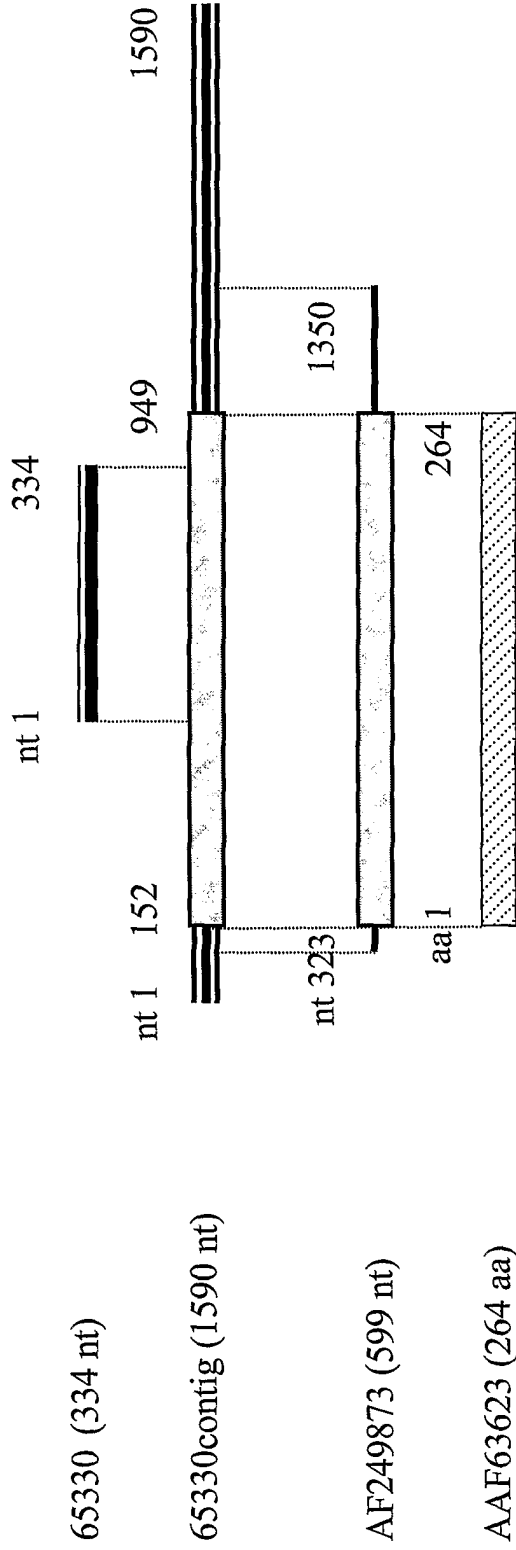
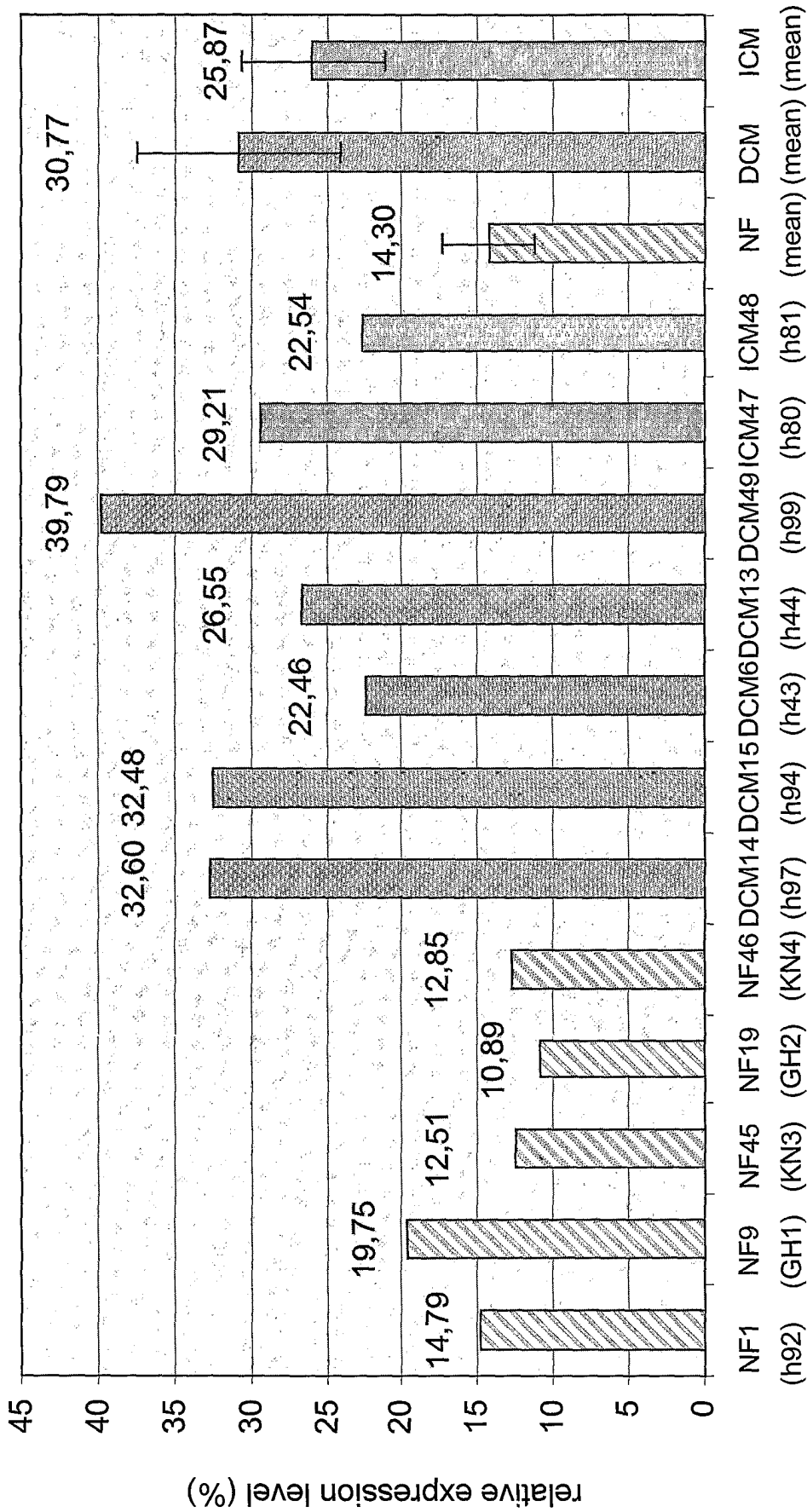

FIG. 8 D



heart tissue sample

FIG. 8 E

Length: 290 nt  
>66214  
1 ACTCCTGAAG TGGAGGAGGG TGTTCCTCCC ACCTCGGATG AGGAGAAGAA GCCAATTCCA  
61 GGAGCGAAGA AACTTCCAGG ACCTGCAGTC AATCTATCGG AAATCCAGAA TATTAAAAGT  
121 GAACTAAAAT ATGTCCCCCAA AGCTGAACAG TAGTAGGAAG AAAAAAGGAT TGATGTGAAG  
181 AAATAAAGAG GCAGAAGATG GATTCAATAG CTCACTAAAA TTTTATATAT TTGTATGATG  
241 ATTGTGAACC TCCTGAATGC CTGAGACTCT AGCAGAAATG GCCTGTTTGT

FIG. 9 A

Length: 886 nt  
 >66214cds  
 1 gttctcaata ccgggagagg cacagagcta tttcagccac atgaaaagca tcggaattga  
 61 gatcgagct cagaggacac cgggcgccc ttcacctc caaggagctt tgtattcttg  
 121 catctggctg cctgggactt cccttaggca gtaaacaaat acataaagca gggataagac  
 181 tgc**at**gtata tgtcgaaca gccagttcc aatgttagag ccatccaggc aaatatcaat  
 241 attccaatgg gagccttctg gccaggagca ggtcaacccc ccagaagaaa agaattgtact  
 301 cctgaagtgg aggaggtgt tcctcccacc tcggatgagg agaagaagcc aattccagga  
 361 gcgaagaaac tccaggacc tgcagtcaat ctatcggaaa tccagaatat taaaagtgaa  
 421 ctaaaatatg tcccaagc tgaacag**tag** taggaagaaa aaaggattga tgtgaagaaa  
 481 taaagaggca gaagatggat tcaatagctc actaaaattt tataatattg tatgatgatt  
 541 gtgaacctcc tgaatgcctg agactctagc agaaatggcc tgtttgtaca tttatatctc  
 601 ttccttctag ttggctgtat ttcttacttt atcttcattt ttggcacctc acagaacaaa  
 661 ttagcccata aattcaacac ctggagggtg tggttttgag gaggatag attttatgga  
 721 gaatgatatg gcaatgtgcc taacgatatt gatgaaaagt tcccaagc acttcctaca  
 781 gtattttggg caatattgg aatgcgtttt agttcttcac cttttaaatt atgtcactaa  
 841 actttgtatg agttcaata aatatttgac taaatgtaaa atgtga

FIG. 9 B

Length: 88 amino acids  
>66214pep

1 MYMSKQPVSN VRAIQANINI PMGAFRPGAG QPRRKECTP EVEEGVPPTS DEEKKPIPGA  
61 KKLPGPAVNL SEIQNIKSEL KYVPKAEQ

FIG. 9 C

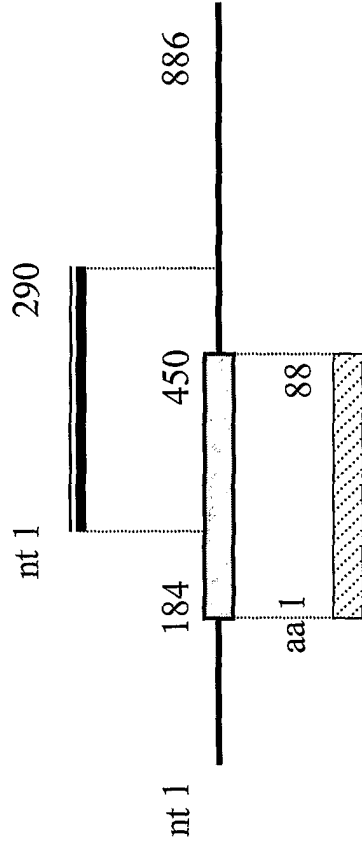

66214 (290 nt)

66214cds or  
AF129505 (886 nt)

66214pep or  
AAF19343 (88 aa)

FIG. 9 D

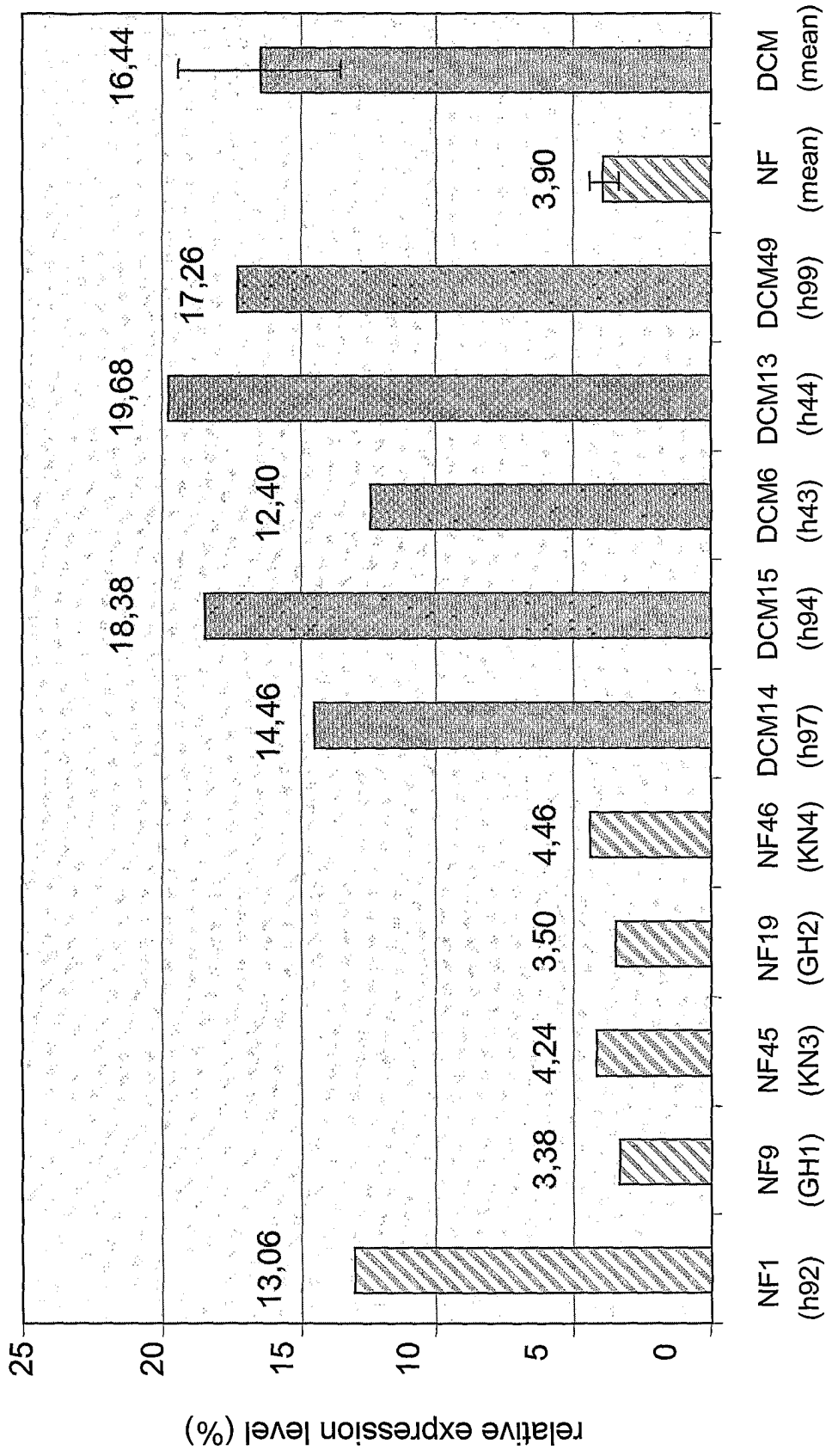

heart tissue sample

FIG. 9 E

Length: 152 nt, 59 nt and 234 nt  
>66268

```

1 CTGATTATCA CAGCCCTCTT TTCTCCTGAA TTTTAAATGC AGAAGTTTGA ATGAAGCAAG
61 GGAAGGCATG TAGGGACAGG AAAGGAAACA ATGGAAGGAA AGTGATTCTG TGAAAAGGAC
121 AGTGAAGCCA GCTATTTTAC CCCCAGGCTG GA

>52474
1 TCCAGGGATT CCTTCCACGA CAGAAAACA TACAAGACTC CTTCAGCCAA CATGATGGT

>S1MC01-1
1 TCCANGGATT CCTTCCACGA CAGAANAACA TACAAGACTC CTTCAGCCAA CATGATGGTA
61 CTGAAAGTAG AGGAACTGGT CACTGGAAG AACAAATGGCA ATGGGGAGGC AGGGGAATTC
121 CTTCCCTGAGG ATTTCAGAGA TGGACAGTNT GAAGCTGCTG TTACTTTAGA GAAGCAGGAG
181 GATCTGAAGA CACTTCTNGC CCACCCCTGTG ACCCTGGGGG AGCAACNGTG GAAA

```

FIG. 10 A

Length: 1901 nt  
 >X83703  
 1 aaaaaacagc agggtagct tgtccctccc ctccctcttc agttcccag aactgattc  
 61 tggaatgaaa attcacctgc ctctgagtg gctcctaag ggggtgggag tgttacttcg  
 121 gttcccaggt tggaagatta tctcaccgg tctcagctat cccagctac cgggtgtggag  
 181 gggcccagca gggccaactc caggattcc ttccacgaca gaaaaacata caagactcct  
 241 tcagccaaca **tg**atggtact gaaagtagag gaaactggtca ctggaagaa gaatggcaat  
 301 ggggaggcag ggaattcct tcctgaggat tcagagatg gagagtatga agctgctggt  
 361 actttagaga agcaggagga tctgaagaca cttctagccc accctgtgac cctgggggag  
 421 caacagtgga aaagcgagaa acaacgagag gcagagctcc caaagaaaaa actagaacaa  
 481 agatccaagc ttgaaaattt agaagacctt gaaataatca ttcaactgaa gaaaaggaaa  
 541 aaatacagga aaactaaagt tccagttgta aaggaaccag aacctgaaat cattacggaa  
 601 cctgtggatg tgcctacgtt tctgaaggct gctctggaga ataaactgcc agtagtagaa  
 661 aaattcttgt cagacaagaa caatccagat gtttgtgatg agtataaacg gacagctctt  
 721 catagagcat gcttggaagg acatttggca attgtggaga agttaatgga agctggagcc  
 781 cagatcgaat tccgtgatat gcttgaatcc acagccatcc actgggcaag ccgtggagga  
 841 aacctggatg ttttaaaatt gttgctgaaat aaaggagcaa aaattagcgc ccgagataag  
 901 ttgctcagca cagcctgca tgtggcgtg aggactggcc actatgagtg cgcggagcat  
 961 cttatgcct gtgaggcaga cctcaacgcc aaagacagag aaggagatac cccgttgcat  
 1021 gatgagggtga gactgaaccg ctataagatg atccgactcc tgattatgta tggcggcggat  
 1081 ctcaacatca agaactgtgc tgggaagacg ccgatggatc tggtgctaca ctggcagaat

FIG. 10 B/1

1141 ggaaccaaaag caatattcga cagcctcaga gagaactcct acaagacctc tcgcatagct  
 1201 acattct**gag** gcaaacgaca gactcttaat cagtaaatgt tcaactggcat tttgaaggca  
 1261 tggcccagga gaagagacac tagccataaa atctagtctc tattatcaa cgtgttgtag  
 1321 agatgtacct aatgaagtct tgagaaagca cagggttata ggtgtttaa tttcctttag  
 1381 tgaactctt attatttt atgtattcct gttatttat ttactgccac gctactgata  
 1441 ttcagacctt catgatcctc catctggtga gcagagcttc attgtatat aacactttca  
 1501 gagccttccc acccataggt agttcttaaa ccaggtgaaa gagcaaatg caagtgccta  
 1561 cttatgtgtc attcgctcat gtaagagtct ttaagagagg gctgattatc acagccctct  
 1621 ttctcctga atthtaatg cagaagtctg aatgaagcaa ggaaggcat gtagggacag  
 1681 gaaaggaaac aatggaagga aagtgattct gtgaaaagga cagtgaagcc agctatttta  
 1741 cccccaggct ggattttttt tttttttttt tttttaccga gtacacagag  
 1801 tacccaagtg aagagaacct catgagtgtg agtgcaaatc agtggaaagga gcggcaaac  
 1861 gggacatgca gaattgaatt tgctcaaaaa aaaaaaaaaa a

FIG 10 B/2

Length: 319 amino acids  
 >CAA58676

```

1  MMVLKVEELV  TGKKNNGEA  GEFLEDFRD  GEYEAAVTLE  KQEDLKTLLA  HPVTLGEQQW
61  KSEKQREAEI  PKKLEQRSK  LENLEDEII  IQLKKRKKYR  KTKVPVVKEP  EPEIITEPVD
121  VPTFLKAALE  NKLPVVEKFL  SDKNNPDVCD  EYKRTALHRA  CLEGHLAIVE  KLMEAGAQIE
181  FRDMLESTAI  HWASRGNLD  VLKLLLNKGA  KISARDKLLS  TALHVAVRTG  HYECAEHLIA
241  CEADLNAKDR  EGDTPLDHDAV  RLNRKYMIRL  LIMYGADLNI  KNCAGKTPMD  LVLHWQNGTK
301  AIFDSLRENS  YKTSRIATF

```

FIG. 10 C

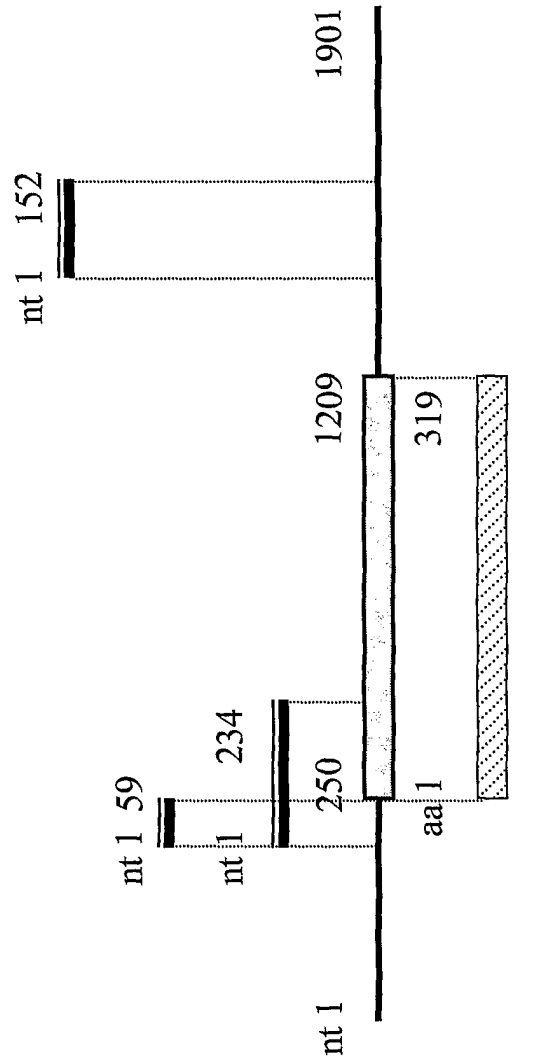

66268 (152 nt)

52474 (59 nt)

S1MC01-1 (234 nt)

X83703 (1901 nt)  
or 66268cds

CAA58676 (319 aa)  
or 66268pep

FIG. 10 D

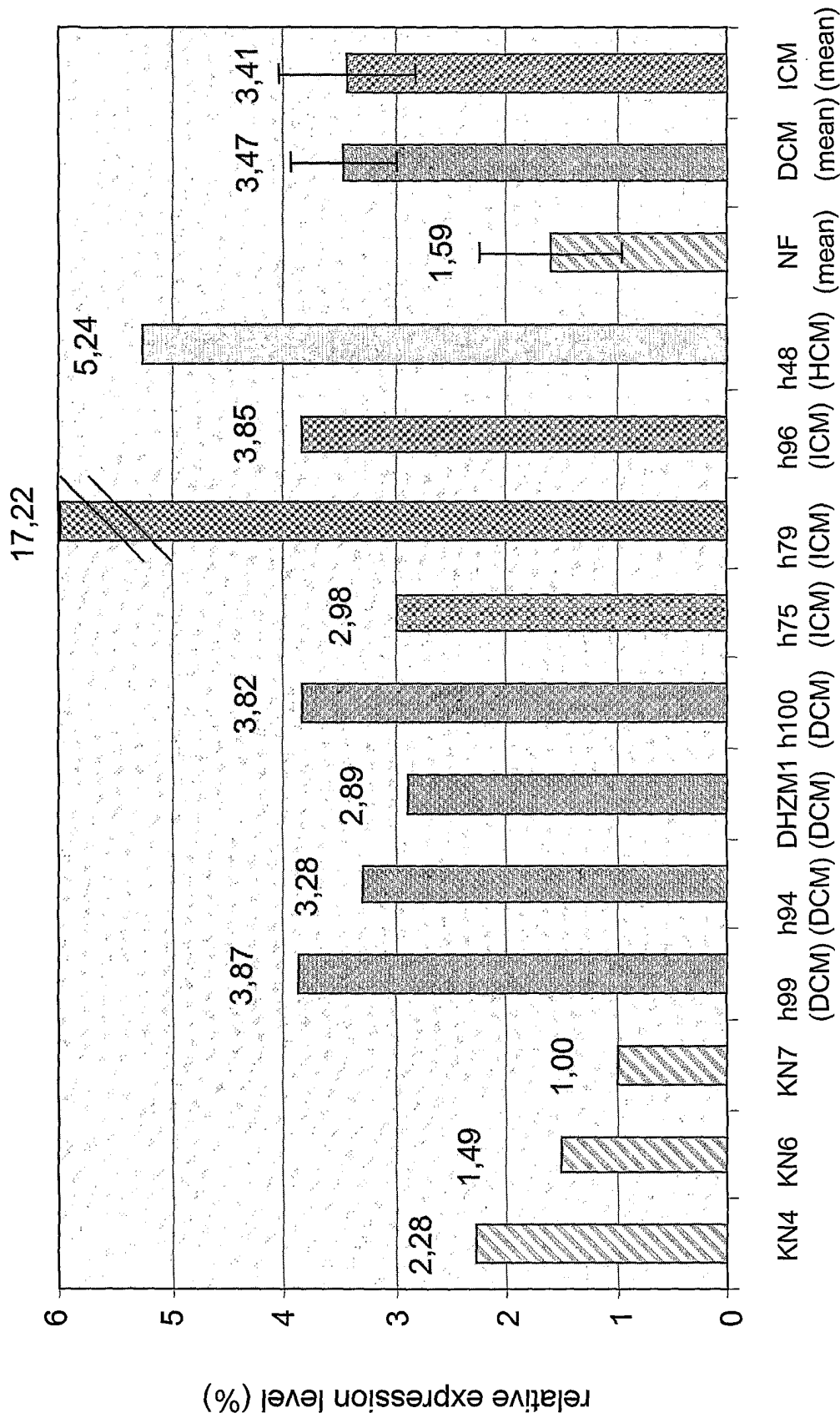

heart tissue sample

FIG. 10 E

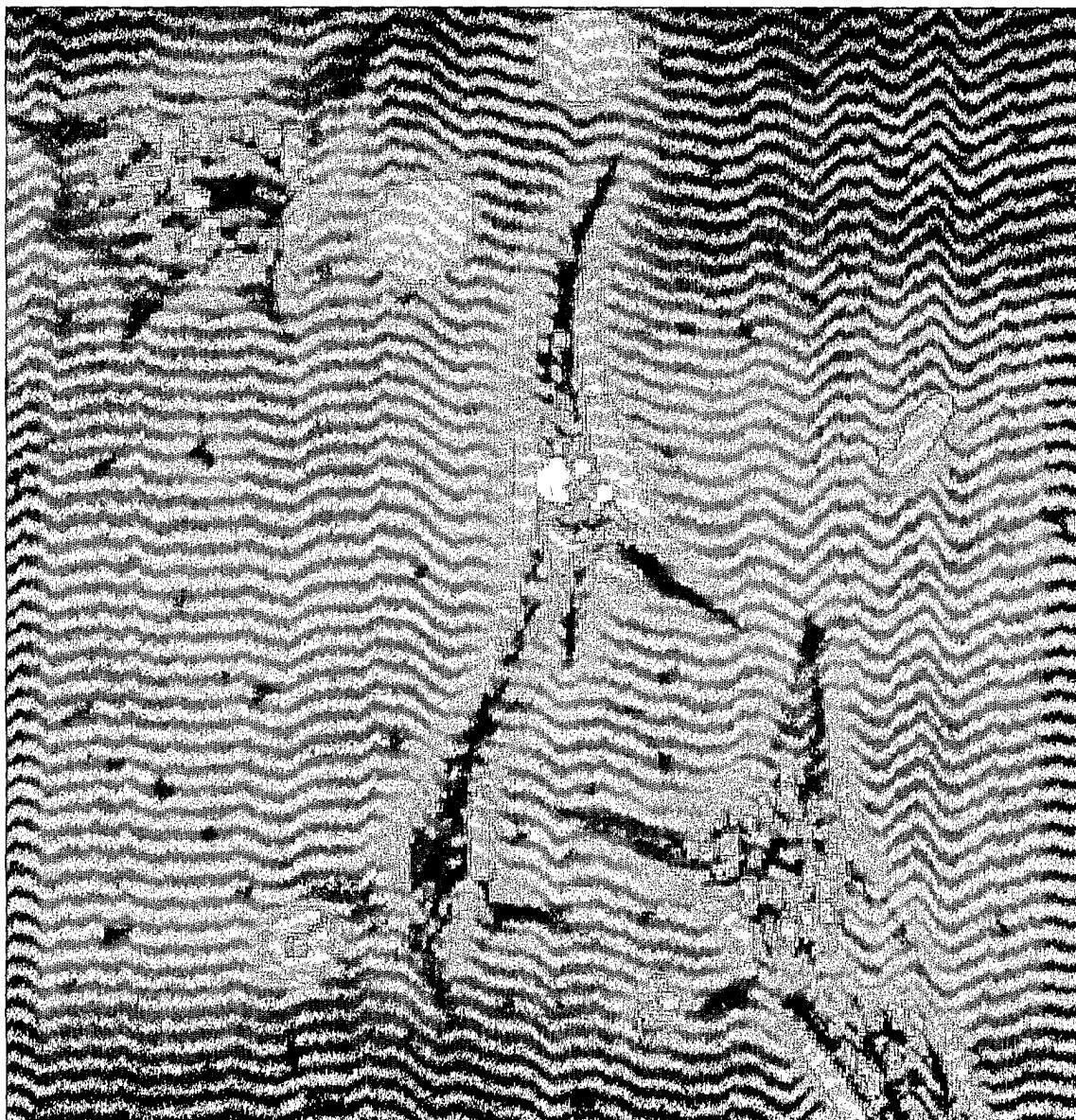

FIG. 10 F

专利名称(译)	用于心脏疾病的新靶基因		
公开(公告)号	<a href="#">EP1311704A2</a>	公开(公告)日	2003-05-21
申请号	EP2001940545	申请日	2001-05-30
[标]申请(专利权)人(译)	麦迪金股份公司		
申请(专利权)人(译)	MediGene公司AG		
当前申请(专利权)人(译)	MediGene公司AG		
[标]发明人	BUNK DANIELA REUNER BIRGIT BECK JOACHIM HENKEL THOMAS STOSS OLIVER		
发明人	BUNK, DANIELA REUNER, BIRGIT BECK, JOACHIM HENKEL, THOMAS STOSS, OLIVER		
IPC分类号	A01K67/027 A61K38/00 A61K45/00 A61K48/00 A61P9/00 A61P9/02 A61P9/04 A61P9/10 A61P9/12 C07K14/47 C12N15/09 C12N15/85 C12Q1/50 C12Q1/68 C12Q1/6883 G01N33/15 G01N33/50 G01N33 /53 G01N33/566 A61K49/00 C07K16/18		
CPC分类号	A01K2217/05 A01K2217/075 A01K2267/03 A01K2267/0375 A61P9/00 A61P9/02 A61P9/04 A61P9/10 A61P9/12 C07K14/47 C12N15/8509 C12Q1/6883 C12Q2600/136 C12Q2600/158		
优先权	60/207400 2000-05-30 US		
外部链接	<a href="#">Espacenet</a>		

#### 摘要(译)

本发明涉及在心脏组织中异常表达的多种基因以及这些基因的片段。评估这些基因的表达水平可用于测试哺乳动物和优选人类对心脏病或这种疾病的急性状态的易感性。根据本发明的优选疾病是充血性心力衰竭，扩张性心肌病，肥厚性心肌病和缺血性心肌病。本发明进一步涉及鉴定能够使上述基因和受异常表达影响的其他基因的表达水平正常化的化合物的方法。所鉴定的化合物可用于配制组合物，优选用于预防或治疗疾病的药物组合物。它们还可以用作先导化合物，用于开发具有改善的效率，更长的半衰期，降低的毒性等并用于治疗心脏病的药物。本发明还包括体细胞基因治疗方法，包括将任何上述基因的至少一个功能性拷贝引入合适的细胞中。最后，本发明涉及非人转基因动物，其在其中包含至少一种上述基因。本发明的转基因动物可用于开发治疗心脏病的药物。