

(19)



(11)

**EP 3 508 848 A1**

(12)

**EUROPEAN PATENT APPLICATION**

(43) Date of publication:  
**10.07.2019 Bulletin 2019/28**

(51) Int Cl.:  
**G01N 33/53** (2006.01)      **G01N 21/75** (2006.01)  
**C12M 1/34** (2006.01)      **G01N 33/558** (2006.01)  
**B01L 3/00** (2006.01)      **G01N 21/64** (2006.01)  
**G01N 33/569** (2006.01)      **G01N 21/03** (2006.01)

(21) Application number: **18215979.8**

(22) Date of filing: **17.12.2013**

(84) Designated Contracting States:  
**AL AT BE BG CH CY CZ DE DK EE ES FI FR GB GR HR HU IE IS IT LI LT LU LV MC MK MT NL NO PL PT RO RS SE SI SK SM TR**  
 Designated Extension States:  
**BA ME**

- **BRODER, Yehoshua**  
9777019 Jerusalem (IL)
- **DAVIS, Bruce**  
9777019 Jerusalem (IL)
- **GOLDMAN, Bruce**  
9777019 Jerusalem (IL)
- **GIRON, Boaz**  
9777019 Jerusalem (IL)
- **BOTESAZAN, Zion**  
9777019 Jerusalem (IL)
- **BLASBERG, Eliezer**  
9777019 Jerusalem (IL)
- **SEMMELE, Ilan**  
9777019 Jerusalem (IL)
- **ASCHKENASY, Jacques**  
9777019 Jerusalem (IL)

(30) Priority: **17.12.2012 US 201261737854 P**  
**17.12.2012 US 201261737856 P**  
**17.12.2012 US 201213716246**

(62) Document number(s) of the earlier application(s) in accordance with Art. 76 EPC:  
**13864008.1 / 2 932 266**

(71) Applicant: **Leukodx Ltd**  
**9777019 Jerusalem (IL)**

(74) Representative: **Pearl Cohen Zedek Latzer Baratz UK LLP**  
**The Gridiron Building**  
**One Pancras Square**  
**London N1C 4AG (GB)**

- (72) Inventors:
- **KASDAN, Harvey, Lee**  
9777019 Jerusalem (IL)
  - **MEISSONNIER, Julien**  
9777019 Jerusalem (IL)
  - **ZUTA, Yoav**  
9777019 Jerusalem (IL)
  - **ROSEN, Micha**  
9777019 Jerusalem (IL)
  - **HIMMEL, Yael**  
9777019 Jerusalem (IL)

Remarks:  
 This application was filed on 31.12.2018 as a divisional application to the application mentioned under INID code 62.

(54) **SYSTEMS AND METHODS FOR DETERMINING A CHEMICAL STATE**

(57) A self-contained system for performing an assay for determining a chemical state, the system including a stationary cartridge for performing the assay therein, at least one reagent adapted to react with a sample; and at least one reporter functionality adapted to report a reaction of the at least one reagent with said sample to report a result of the assay, wherein the at least one reagent, the sample and the at least one reporter functionality are contained within the cartridge.

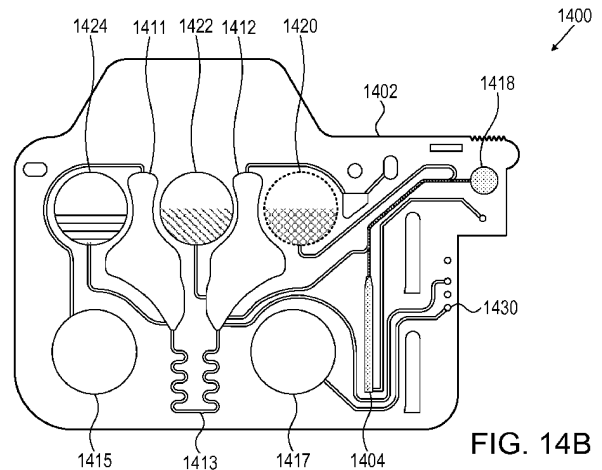

**FIG. 14B**

**EP 3 508 848 A1**

**Description****CROSS REFERENCE TO RELATED APPLICATIONS**

5 [0001] The present invention claims priority from US provisional patent application 61/737,854, to Kasdan et al, filed on December 17th, 2012, from US provisional patent application 61/737,856, to Kasdan et al., filed on December 17, 2012 and from US Patent Application no. 13/716,246 filed on December 17, 2012, incorporated herein by reference.

**FIELD OF THE INVENTION**

10 [0002] The present invention relates generally to apparatus and methods for detecting a biological condition, and more specifically to methods and apparatus for detecting a biological condition in small fluid samples.

**BACKGROUND OF THE INVENTION**

15 [0003] There are numerous medical conditions which are hard to diagnose. Often diagnosis by a physician is based on the physician's observation of combinations of symptoms in a patient. This sometimes leads to misdiagnosis. Furthermore, the patient's response to a treatment, whether drug or other modality is often followed up by physician's observation.

20 [0004] Many laboratory tests are performed in the diagnostic arena on a bodily specimen or fluid to determine a biological condition in a patient. However, these tests are performed off-line in diagnostic laboratories. Often, the laboratory services are only provided during a single 8-hour shift during the day and tend to be labor intensive.

[0005] Some prior art publications in the field include, *inter alia*,

25 [0006] US 8,116,984 to Davis et al., discloses a method of quantifying CD64 and CD163 expression in leukocytes and, specifically to a kit for use with a flow cytometer including a suspension of quantitative fluorescent microbead standards, fluorescent labeled antibodies directed to CD64 and CD163, and analytical software. The software is used to take information on the microbead suspension and fluorescent labeled antibodies from a flow cytometer and analyze data, smooth curves, calculate new parameters, provide quality control measures and notify of expiration of the assay system.

30 [0007] Several developments have been published in the micro-fluidics field, such as: US2006215155A, which describes a flow cell comprising a layered arrangement of three plates (3 - 5) in which an intermediate plate (4) consisting of a flexible material is inserted between plates (3, 5) consisting of a more solid material, and at least one of the plates comprises at least one recess (15, 17) for receiving fluid, that is bordered by another plate (3, 5) of the layered arrangement. Such recesses are especially microchannels and reaction chambers. According to the invention, the plates are inter-

35 [0008] WO12019599A describes a microfluidic device for transporting a fluid, in particular a micropump or microvalve. The device according to the invention is characterized by films (2, 3), which lie against each other at film surfaces facing each other and are connected to each other in such a way that a transport channel (19) to be formed between the films (2, 3) is defined, and by deflecting apparatuses for forming the transport channel (19) by jointly deflecting the films (2, 3) lying against each other in a direction perpendicular to the film surfaces, wherein a deflecting surface region (12) of the rear film (2) in the deflection direction lies within the deflecting surface region (14) of the front film (3) in the deflection direction defined by the connection (15) between the films (2, 3).

40 [0009] US2012187117A discloses a fluid reservoir, in particular a fluid reservoir to be integrated into a miniaturized flow cell, comprising a reservoir space, which is enclosed by two bodies (6,7) that lie against each other in a fluid-tight manner. According to the invention, in addition to a stored liquid (9), a solid filling body (12) that fills the remaining reservoir space is arranged in the reservoir space. A part of the reservoir space filled by the stored liquid is preferably bounded predominately by one of the two bodies (6,7) and the solid filling body (12).

45 [0010] Typical turnaround times for diagnostic prior art assays are 30-120 minutes. Often, the time lost in waiting for laboratory results can lead to a further deterioration in a patient, and sometimes death. In some cases, the physician has to act without having the laboratory results. This can lead to providing the patient with the wrong treatment. There is thus a need to provide rapid assays to save lives and provide fast correct treatments to a patient. Despite the inventions described hereinabove, there still remains an unmet need to provide improved apparatus and methods for detecting and diagnosing biological conditions in a patient.

50 [0011] There are many other diagnostic tests, such as to water samples, to detect toxins and contaminants that currently have a long turnaround. There still is an unmet need to provide systems, kits and methods to provide quantitative and/or qualitative tests for determining a chemical state.

## SUMMARY OF THE INVENTION

**[0012]** It is an object of some aspects of the present invention to provide improved apparatus and methods for detecting a chemical state of a sample.

**[0013]** In some embodiments of the present invention, improved methods, systems, apparatus and kits are provided for detecting and diagnosing a biological condition in a patient.

**[0014]** In other embodiments of the present invention, a method and system are described for providing rapid detection of biological moieties in a sample from a patient.

**[0015]** In further embodiments of the present invention, a method and kit are disclosed for providing detection of biological moieties in a small fluid sample from a patient.

**[0016]** It is an object of some aspects of the present invention to provide improved apparatus and methods for detecting a chemical entity in small fluid samples.

**[0017]** In some embodiments of the present invention, improved rapid methods, apparatus and kits are provided for detecting chemical entities.

**[0018]** In some embodiments of the present invention, improved rapid methods, apparatus and kits are provided for detecting biological entities.

**[0019]** In further embodiments of the present invention, a method and kit are disclosed for providing detection of biological and/or chemical moieties in a small fluid samples.

**[0020]** In further embodiments of the present invention, a microfluidics method, apparatus and kit are disclosed for providing detection of biological and/or chemical moieties in a small fluid samples.

**[0021]** There is thus provided according to an embodiment of the present invention, a self-contained system for performing an assay for determining a chemical state, the system including;

- a. a stationary cartridge for performing the assay therein;
- b. at least one reagent adapted to react with a sample; and
- c. at least one reporter functionality adapted to report a reaction of the at least one reagent with the sample to report a result of the assay;

wherein the at least one reagent, the sample and the at least one reporter functionality are contained within the cartridge.

**[0022]** Additionally, according to an embodiment of the present invention, the assay is a flow cytometric assay.

**[0023]** Furthermore, according to an embodiment of the present invention, the chemical state is a biochemical state.

**[0024]** Moreover, according to an embodiment of the present invention, the biochemical state is indicative of a biological condition.

**[0025]** Further, according to an embodiment of the present invention, the sample is a biological sample.

**[0026]** Yet further, according to an embodiment of the present invention, the biological sample is a bodily sample.

**[0027]** Additionally, according to an embodiment of the present invention, the bodily sample is selected from a the group consisting of blood, serum, plasma, urine, saliva, cerebrospinal fluid (CSF), serous fluid, peritoneal fluid and synovial fluid blood, urine, plasma, serum and saliva.

**[0028]** Importantly, according to an embodiment of the present invention, the cartridge is valveless.

**[0029]** Notably, according to an embodiment of the present invention, the cartridge is a disposable microfluidics cartridge.

**[0030]** Additionally, according to an embodiment of the present invention, the at least one reagent includes at least one of;

- a. at least one target antibody;
- b. at least one positive control identifying antibody; and
- c. at least one negative control identifying detection moiety.

**[0031]** Furthermore, according to an embodiment of the present invention, the at least one reagent includes at least one reference composition including at least one of;

- a. a target signal reference composition; and
- b. a reference identifier composition.

**[0032]** There is thus provided according to another embodiment of the present invention, a method for performing an assay for determining a chemical state in a self-contained stationary cartridge, the method including;

- a. introducing a sample into the cartridge;

- b. reacting at least one reagent with the sample; and
- c. detecting a signal associated with at least one reporter functionality, the at least one reporter functionality adapted to report a reaction of the at least one reagent with the sample, thereby determining the chemical state.

5 [0033] Additionally, according to an embodiment of the present invention, the method further includes forming at least one product and detecting a signal associated with the product.

[0034] Moreover, according to an embodiment of the present invention, the assay is a flow cytometric assay.

[0035] Furthermore, according to an embodiment of the present invention, the chemical state is a biochemical state.

10 [0036] Notably, according to an embodiment of the present invention, the biochemical state is indicative of a biological condition.

[0037] Further, according to an embodiment of the present invention, the sample is a biological sample.

[0038] Yet further, according to an embodiment of the present invention, the biological sample is a bodily sample.

[0039] Additionally, according to an embodiment of the present invention, the bodily sample is selected from the group consisting of blood, serum, plasma, urine, saliva, cerebrospinal fluid (CSF), serous fluid, peritoneal fluid and synovial fluid.

15 [0040] Furthermore, according to an embodiment of the present invention, the at least one reagent includes;

- a. a cell surface marker;
- b. a cell stain;
- c. a reagent bound to a solid support;
- 20 d. a chemical indicator; and
- e. a biological cell indicator.

[0041] Additionally, according to an embodiment of the present invention, the cell surface marker is selected from the group consisting of CD64, CD4, CD8, a stem cell indicator, a Minimal Residual Disease indicator and a lymphocyte subtype indicator.

25 [0042] Moreover, according to an embodiment of the present invention, the cell stain is selected from the group consisting of a white blood cell differential indicator, an apoptosis indicator.

[0043] Furthermore, according to an embodiment of the present invention, the reagent bound to the solid support is selected from the group consisting of an immobilized enzyme, an immobilized substrate, a plasma protein bead, an antibody bead, an antigen bead and an ELISA assay.

30 [0044] Further, according to an embodiment of the present invention, the chemical indicator is selected from the group consisting of a color indicator, a turbidity indicator, a pH indicator, an adsorption indicator, an emission indicator and a chemical reaction indicator.

[0045] Yet further, according to an embodiment of the present invention, the biological cell indicator is selected from the group consisting of a cell cycle stage indicator, a cell proliferation indicator, a cytokine indicator, a metabolic indicator and an apoptosis indicator.

35 [0046] Additionally, according to an embodiment of the present invention, the at least one reagent includes at least two reagents.

[0047] Furthermore, according to an embodiment of the present invention, the at least two reagents include at least one of;

- a. a cell surface marker and a cell element stain;
- b. a cell surface marker and a plasma protein bead assay;
- c. a cell surface marker and a solution change marker;
- 45 d. a cell element stain and a plasma protein bead assay; and
- e. a cell element stain and a solution change marker.

[0048] Additionally, according to an embodiment of the present invention, the biological condition is selected from blood diseases such as leukemia, thrombocytopenia immune system disorders, local infections, urinary tract disorders, autoimmune diseases and sepsis.

50 [0049] There is thus provided, according to an additional embodiment of the present invention, a method for forming a chemical reaction in a stationary cartridge, the method including;

- a. storing at least one composition in the cartridge; and
- 55 b. activating at least one inflatable chamber to provide at least one pressure force to the at least one composition thereby inducing the chemical reaction.

[0050] Additionally, according to an embodiment of the present invention, the cartridge is a valveless cartridge.

**[0051]** Additionally, according to an embodiment of the present invention, the at least one composition includes at least two compositions.

**[0052]** Furthermore, according to an embodiment of the present invention, the at least one pressure force is a positive pressure force.

5 **[0053]** Further, according to an embodiment of the present invention, the at least one pressure force is a negative pressure force.

**[0054]** Importantly, according to an embodiment of the present invention, the at least one pressure force includes at least one positive pressure force and at least one negative pressure force.

10 **[0055]** Additionally, according to an embodiment of the present invention, the at least one positive pressure force and at least one negative pressure force include alternating positive and negative pressure forces.

**[0056]** Furthermore, according to an embodiment of the present invention, the at least one inflatable chamber includes two one inflatable chambers.

**[0057]** Further, according to an embodiment of the present invention, the chemical reaction includes at least one intermediate.

15 **[0058]** Additionally, according to an embodiment of the present invention, the at least one pressure force is provided sequentially to a several combinations of compositions of the at least one composition.

**[0059]** According to an embodiment of the present invention, the method further includes introducing a specimen to the cartridge before the activating step.

**[0060]** Additionally, according to an embodiment of the present invention, the specimen is a bodily sample.

20 **[0061]** Moreover, according to an embodiment of the present invention, the chemical reaction provides a flow cytometric assay result to the bodily sample.

**[0062]** Furthermore, according to an embodiment of the present invention, the chemical reaction is for determining a biological condition in a mammalian subject.

25 **[0063]** Additionally, according to an embodiment of the present invention, the method further includes;

- c) incubating a specimen from the subject in the cartridge for a predetermined period of time; and
- d) receiving an indication responsive to at least one reporter element thereby providing the indication of the biological condition in the subject.

30 **[0064]** Additionally, according to an embodiment of the present invention, the biological condition is selected from blood diseases such as leukemia, thrombocytopenia immune system disorders, local infections, urinary tract disorders, autoimmune diseases and sepsis.

**[0065]** Furthermore, according to an embodiment of the present invention, at least one composition disposed in the cartridge includes a sepsis biomarker.

35 **[0066]** Further, according to an embodiment of the present invention, the biomarker includes at least one of CD64 and CD163.

**[0067]** Additionally, according to an embodiment of the present invention, the indication is quantitative.

**[0068]** Importantly, according to an embodiment of the present invention, the sample is of a volume of less than 200 microliters ( $\mu\text{L}$ ).

40 **[0069]** Additionally notably, according to an embodiment of the present invention, the method is completed within twenty minutes. In some cases, the method is completed within fifteen minutes, ten minutes or five minutes.

**[0070]** There is thus provided according to an embodiment of the present invention, a method for determining a biological condition in a mammalian subject, the method including;

- 45 a) incubating a specimen from the subject with at least one composition in a stationary cartridge as described herein, for a predetermined period of time to form at least one reaction product, when the subject has the biological condition; and
- b) receiving an indication of the at least one reaction product responsive to at least one reporter element in the method thereby providing the indication of the biological condition in the subject.

50 **[0071]** There is thus provided according to an embodiment of the present invention, a microfluidics kit for detecting a chemical entity, the kit comprising;

- 55 a) a disposable element for receiving a sample and for combining said sample with at least one composition;
- b) at least one composition comprising at least one detector moiety adapted to react with said sample to form a reaction product; and
- c) at least one reporter element adapted to provide an indication of reaction product thereby providing the indication of the presence of the chemical entity.

[0072] Additionally, according to an embodiment of the present invention, the kit further comprises;

d) instructions for using the kit.

5 [0073] There is thus provided according to an embodiment of the present invention, a kit for evaluating a biological condition in a patient, the kit comprising;

a) a disposable element for receiving a biological specimen and for combining said specimen with at least one composition;

10 b) at least one composition comprising at least one detector moiety adapted to react with said specimen to form a reaction product, when said patient has said biological condition; and

c) at least one reporter element adapted to provide an indication of reaction product thereby providing the indication of the biological condition.

15 [0074] Additionally, according to an embodiment of the present invention, the kit further comprises;

d) instructions for using the kit.

[0075] Furthermore, according to an embodiment of the present invention, the disposable element is a disposable cartridge.

20 [0076] Moreover, according to an embodiment of the present invention, the disposable cartridge is a disposable microfluidics cartridge.

[0077] Additionally, according to an embodiment of the present invention, the disposable microfluidics cartridge comprises at least one of the following elements;

25

a) a reservoir;

b) a pump;

c) a conduit;

d) a miniaturized flow cell;

30 e) a transport channel;

f) a microfluidic element;

g) a compressed gas holding element

h) a compressed gas releasing element;

i) a nozzle element;

35 j) a mixing element;

k) a bellows element.

l) software adapted to activate said elements according to a specific sequence; and

m) hardware to activate said elements according to a specific sequence.

40 [0078] Additionally, according to an embodiment of the present invention, the disposable microfluidics cartridge comprises at least two of the elements.

[0079] Additionally, according to an embodiment of the present invention, the disposable microfluidics cartridge comprises at least three of the elements.

45 [0080] Additionally, according to an embodiment of the present invention, the disposable microfluidics cartridge comprises at least four of the elements.

[0081] Additionally, according to an embodiment of the present invention, the disposable microfluidics cartridge comprises at least five of the elements.

[0082] Additionally, according to an embodiment of the present invention, the disposable microfluidics cartridge comprises at least ten of the elements.

50 [0083] Additionally, according to an embodiment of the present invention, the disposable microfluidics cartridge comprises at least twenty of the elements.

[0084] Additionally, according to an embodiment of the present invention, the disposable microfluidics cartridge comprises at least thirty of the elements.

55 [0085] According to an embodiment of the present invention, the microfluidics kit is configured to provide the rapid indication with one hour.

[0086] According to another embodiment of the present invention, the microfluidics kit is configured to provide the rapid indication with thirty minutes.

[0087] According to another embodiment of the present invention, the microfluidics kit is configured to provide the

rapid indication with fifteen minutes.

**[0088]** According to another embodiment of the present invention, the microfluidics kit is configured to provide the rapid indication with ten minutes.

5 **[0089]** According to another embodiment of the present invention, the microfluidics kit is configured to provide the rapid indication with five minutes.

**[0090]** According to another embodiment of the present invention, the microfluidics kit is configured to provide the rapid indication with one minute.

**[0091]** According to another embodiment of the present invention, the microfluidics kit is configured to provide the rapid indication with thirty seconds.

10 **[0092]** According to another embodiment of the present invention, the microfluidics kit is configured to provide the rapid indication with ten seconds.

**[0093]** According to another embodiment of the present invention, the microfluidics kit is configured to provide the rapid indication with one second.

15 **[0094]** There is thus provided according to an embodiment of the present invention, a microfluidics assay kit for performing a rapid biological assay, the kit comprising;

a) a disposable element comprising a reactant, the disposable element being adapted to receive a sample comprising a biological entity and for combining said reactant with said biological entity to form a reaction product; and

20 b) at least one reporter element adapted to provide a rapid indication of disappearance of said reactant thereby providing rapid assay of the biological entity.

**[0095]** There is thus provided according to an embodiment of the present invention, a microfluidics assay kit for performing a rapid assay of a biological entity, the kit comprising;

25 a) a disposable element comprising a reactant, the disposable element being adapted to receive a sample comprising the biological entity and for combining said reactant with said biological entity to form a reaction product; and

b) at least one reporter element adapted to provide a rapid indication of appearance of said reaction product thereby providing rapid assay of the biological entity.

30 **[0096]** There is thus provided according to an embodiment of the present invention, a composition for evaluating a biological condition, the composition comprising;

a. a sample composition comprising at least one of;

35 i. a bodily specimen comprising a target moiety;

ii. a positive control moiety; and

iii. a negative control moiety;

b. a detection composition comprising at least one of;

40

i. at least one target antibody;

ii. at least one positive control identifying antibody; and

iii. at least one negative control identifying detection moiety or characteristic; and

45 c. at least one reference composition comprising at least one of;

i. a target signal reference composition; and

ii. a reference identifier composition.

50 **[0097]** There is thus provided according to another embodiment of the present invention a composition for evaluating a biological condition, the composition comprising;

a. a sample composition comprising at least one of;

55 i. a bodily specimen comprising a target moiety;

ii. a positive control moiety; and

iii. a negative control moiety;

- b. an antibody composition comprising at least one of;
- i. at least one target antibody (CD64 antibody);
  - ii. at least one positive control identifying antibody (CD163); and
  - iii. at least one negative control identifying antibody or characteristic; and

- c. at least one reference composition comprising at least one of;

- i. a target signal reference composition; and
- ii. a reference identifier composition.

**[0098]** Additionally, according to an embodiment of the present invention, the composition further comprises at least one conditioning moiety comprising;

- d. at least one lysis reagent; and
- e. at least one diluent.

**[0099]** Furthermore, according to an embodiment of the present invention, the biological condition is selected from a group consisting of blood diseases such as leukemia, thrombocytopenia immune system disorders, local infections, urinary tract disorders, autoimmune diseases and sepsis.

**[0100]** Moreover, according to an embodiment of the present invention the bodily specimen is selected from a group consisting of blood, serum, plasma, urine, saliva, cerebrospinal fluid (CSF), serous fluid, peritoneal fluid and synovial fluid.

**[0101]** According to another embodiment of the present invention, the target moiety includes a CD64 surface antigen on neutrophils.

**[0102]** Additionally, according to a further embodiment of the present invention, the positive control moiety includes monocytes and the negative control includes lymphocytes.

**[0103]** Additionally, according to an embodiment of the present invention, the target moiety is CD64 on neutrophils, the positive control moiety includes CD64 expression on monocytes, and the negative control moiety includes lymphocytes without CD64 expression.

**[0104]** Further, according to an embodiment of the present invention, the target indicator is bound to a signaling moiety on the at least one target antibody.

**[0105]** Yet further, according to an embodiment of the present invention, the at least one reference composition includes beads.

**[0106]** Additionally, according to an embodiment of the present invention, the beads include polystyrene microbeads.

**[0107]** Moreover, according to an embodiment of the present invention, the target antibody reference composition includes a first fluorescent signal and the reference identifier composition includes a second fluorescent signal.

**[0108]** Furthermore, according to an embodiment of the present invention, the first fluorescent signal includes FITC and the second fluorescent signal includes Starfire Red fluor.

**[0109]** There is thus provided according to an embodiment of the present invention, a method of quantifying a biomarker in a sample, comprising;

- a. contacting the sample with a fluorescently-labeled binding moiety that specifically binds to the biomarker;
- b. detecting a first fluorescent signal from at least a portion of the labeled sample;
- c. detecting a second fluorescent signal from a population of fluorescently-labeled particles, wherein the population includes a known fluorescent intensity over a fixed time; and
- d. normalizing the first fluorescent signal to the second fluorescent signal, thereby quantifying the biomarker, wherein the normalizing includes using a device comprising software capable of comparing the first and second fluorescent signal.

**[0110]** Furthermore, according to an embodiment of the present invention, the biomarker is a sepsis biomarker.

**[0111]** Moreover, according to an embodiment of the present invention, the biomarker is CD64 or CD163.

**[0112]** Additionally, according to an embodiment of the present invention, the sample is a blood sample.

**[0113]** According to another embodiment of the present invention, the fluorescent label of the binding moiety and the fluorescent label of the particles is the same fluorescent label.

**[0114]** Further, according to an embodiment of the present invention, the binding moiety is an antibody.

**[0115]** According to an embodiment of the present invention, the software is capable of recognizing a specific lot of fluorescently-labeled particles.

**[0116]** Moreover, according to an embodiment of the present invention, the individual fluorescent signals include at

least one first fluorescent signal and at least one second fluorescent signal.

**[0117]** Additionally, according to an embodiment of the present invention the fluorescently-labeled binding moiety targets a first cell population and a second cell population in the sample.

5 **[0118]** According to another embodiment of the present invention the detection of binding of the binding moiety to the second cell population provides an internal positive control for the sample.

**[0119]** Furthermore, according to an embodiment of the present invention, the binding moiety is anti-CD64 antibody and the first cell population includes neutrophil leukocytes.

**[0120]** Yet further, according to an embodiment of the present invention, the second cell population includes monocytes.

10 **[0121]** According to an embodiment of the present invention, the method further comprises the step of determining the presence of at least one cell population in the sample that is not bound by the binding moiety, thus providing an internal negative control for the sample.

**[0122]** There is thus provided according to another embodiment of the present invention, a composition for evaluating a biological condition, the composition comprising;

15 a. a sample comprising at least one of;

- i. a bodily specimen comprising a target moiety;
- ii. a positive control moiety; and
- iii. a negative control moiety;

20

b. an antibody composition comprising at least one of;

- i. at least one target antibody (cd64 antibody);
- ii. at least one positive control identifying antibody (CD163) ; and
- iii. at least one negative control identifying antibody or characteristic (scatter); and

25

c. at least one reference composition (beads) comprising at least one of;

- i. a target antibody reference composition; and
- ii. a reference identifier composition.

30

**[0123]** According to an embodiment of the present invention, the composition further comprises at least one conditioning moiety comprising;

- 35 a) at least one lysis reagent; and  
b) at least one diluent.

**[0124]** There is thus provided according to another embodiment of the present invention, a method of determining the presence or absence of sepsis in a subject, the method including;

40

- a) contacting a blood sample from the subject with a fluorescently-labeled binding moiety specific to a sepsis marker, wherein the volume of the blood sample is 50  $\mu$ L or smaller; and
- b) detecting the presence, absence or level of the binding moiety in the sample, thereby determining the presence or absence of sepsis in the subject.

45

**[0125]** There is thus provided according to another embodiment of the present invention, a method of quantifying a biomarker in a sample, comprising;

- a) contacting the sample with a fluorescently-labeled binding moiety that specifically binds to the biomarker;
- b) detecting a first fluorescent signal from at least a portion of the labeled sample;
- c) detecting a second fluorescent signal from a population of fluorescently-labeled particles, wherein the population includes a known fluorescent intensity over a fixed time; and
- d) normalizing the first fluorescent signal to the second fluorescent signal, thereby quantifying the biomarker, wherein the normalizing includes using a device comprising software capable of comparing the first and second fluorescent signal.

55

**[0126]** There is thus provided according to an embodiment of the present invention, a method of quantifying a second biomarker in a sample, comprising;

- a. contacting the sample with a first fluorescently-labeled binding moiety that specifically binds to a first biomarker;
- b. contacting the sample with a second fluorescently-labeled binding moiety that specifically binds to a second biomarker;
- c. detecting a first fluorescent signal from at least a portion of the labeled sample;
- d. detecting a second fluorescent signal from a population of fluorescently-labeled particles, wherein the population includes a known fluorescent intensity over a fixed time; and
- e. normalizing the first fluorescent signal to the second fluorescent signal, thereby quantifying the second biomarker, wherein the normalizing includes using a device comprising software capable of comparing the first and second fluorescent signal.

**[0127]** According to some embodiments, the sample may be liquid, according to other embodiments, the sample may be a colloid or suspension. According to further embodiments, the sample may be a solid, such as in a powder or crystal form.

**[0128]** There is thus provided according to an embodiment of the present invention, a microfluidics kit for performing a chemical reaction, the kit comprising;

- a) a disposable element for receiving a sample and for combining said sample with at least one composition;
- b) at least one composition comprising at least one detector moiety adapted to react with said sample to form a reaction product; and
- c) at least one reporter element adapted to provide an indication of said reaction product

**[0129]** There is thus provided according to an embodiment of the present invention, a microfluidics kit for performing a chemical reaction, the kit comprising;

- a) a disposable element for receiving a sample and for combining said sample with at least one composition;
- b) at least one composition comprising at least one detector moiety adapted to react with said sample to form a reaction product; and
- c) at least one reporter element adapted to provide an indication of disappearance of a reactant in said sample thereby providing the indication of the presence of the reaction product.

**[0130]** There is thus provided according to an embodiment of the present invention, a microfluidics kit for performing a chemical reaction, the kit comprising;

- a) a disposable element for receiving a first reactant and for combining said first reactant with at least one composition;
- b) at least one composition comprising at least one detector moiety adapted to react with a reaction product; and
- c) at least one reporter element adapted to provide an indication said of at least one detector moiety thereby providing the indication of the presence of the reaction product.

**[0131]** There is thus provided according to an embodiment of the present invention, a microfluidics kit for performing a rapid detection of a chemical entity, the kit comprising;

- a) a disposable element for receiving a first reactant and for combining said sample with at least one composition;
- b) at least one composition comprising at least one detector moiety adapted to react with a reaction product; and
- c) at least one reporter element adapted to provide a rapid indication said of at least one detector moiety thereby providing rapid detection of the chemical entity.

**[0132]** There is thus provided according to an embodiment of the present invention, a microfluidics kit for performing a rapid detection of a chemical entity, the kit comprising;

- a) a disposable element for receiving a first reactant and for combining said sample with at least one composition to form a reaction product;
- b) at least one detector moiety adapted to react with a reaction product; and
- c) at least one reporter element adapted to provide a rapid indication said of at least one detector moiety thereby providing rapid detection of the chemical entity.

**[0133]** There is thus provided according to an embodiment of the present invention, a microfluidics kit for performing a rapid detection of a chemical entity, the kit comprising;

- a) a disposable element for receiving a first reactant and for combining said sample with at least one composition to form a reaction product; and  
b) at least one reporter element adapted to provide a rapid indication said of reaction product thereby providing rapid detection of the chemical entity.

5

**[0134]** There is thus provided according to an embodiment of the present invention, a microfluidics kit for performing a rapid detection of a chemical entity, the kit comprising;

- a) a disposable element for receiving a first reactant and for combining said sample with at least one composition to form a reaction product; and  
b) at least one reporter element adapted to provide a rapid indication of disappearance of said chemical entity thereby providing rapid detection of the chemical entity.

10

**[0135]** According to an embodiment of the present invention, the microfluidics kit is configured to provide the rapid indication with one hour.

15

**[0136]** According to another embodiment of the present invention, the microfluidics kit is configured to provide the rapid indication with thirty minutes.

**[0137]** According to another embodiment of the present invention, the microfluidics kit is configured to provide the rapid indication with fifteen minutes.

20

**[0138]** According to another embodiment of the present invention, the microfluidics kit is configured to provide the rapid indication with ten minutes.

**[0139]** According to another embodiment of the present invention, the microfluidics kit is configured to provide the rapid indication with five minutes.

**[0140]** According to another embodiment of the present invention, the microfluidics kit is configured to provide the rapid indication with one minute.

25

**[0141]** According to another embodiment of the present invention, the microfluidics kit is configured to provide the rapid indication with thirty seconds.

**[0142]** According to another embodiment of the present invention, the microfluidics kit is configured to provide the rapid indication with ten seconds.

30

**[0143]** According to another embodiment of the present invention, the microfluidics kit is configured to provide the rapid indication with one second.

**[0144]** There is thus provided according to an embodiment of the present invention, a microfluidics kit for performing a rapid detection of a chemical entity, the kit comprising;

- a) a disposable element for receiving a first reactant and for combining said sample with at least one composition to form a reaction product; and  
b) at least one reporter element adapted to provide a rapid indication said of reaction product thereby providing rapid detection of the chemical entity.

35

**[0145]** There is thus provided according to an embodiment of the present invention, a microfluidics kit for performing a rapid detection of a chemical entity, the kit comprising;

40

- a) a disposable element for receiving a first reactant and for combining said sample with at least one composition to form a reaction product; and  
b) at least one reporter element adapted to provide a rapid indication of disappearance of said chemical entity thereby providing rapid detection of the chemical entity.

45

**[0146]** There is thus provided according to an embodiment of the present invention, a microfluidics assay kit for assaying a chemical entity, the kit comprising;

50

- a) a disposable element for receiving a sample and for combining said sample with at least one composition;  
b) at least one composition comprising at least one detector moiety adapted to react with said sample to form a reaction product; and  
c) at least one reporter element adapted to provide an indication of reaction product thereby providing the assay of the chemical entity.

55

**[0147]** Additionally, according to an embodiment of the present invention, the kit further comprises;

d) instructions for using the kit.

**[0148]** Furthermore, according to an embodiment of the present invention, the disposable element is a disposable cartridge.

5 **[0149]** Moreover, according to an embodiment of the present invention, the disposable cartridge is a disposable microfluidics cartridge.

**[0150]** There is thus provided according to another embodiment of the present invention, a method of quantifying a biomarker in a sample, comprising;

- 10 a) contacting the sample with a fluorescently-labeled binding moiety that specifically binds to the biomarker;  
 b) detecting a first fluorescent signal from at least a portion of the labeled sample;  
 c) detecting a second fluorescent signal from a population of fluorescently-labeled particles, wherein the population includes a known fluorescent intensity over a fixed time; and  
 15 d) normalizing the first fluorescent signal to the second fluorescent signal, thereby quantifying the biomarker, wherein the normalizing includes using a device comprising software capable of comparing the first and second fluorescent signal.

**[0151]** There is thus provided according to an embodiment of the present invention, a method of quantifying a second biomarker in a sample, comprising;

- 20 a. contacting the sample with a first fluorescently-labeled binding moiety that specifically binds to a first biomarker;  
 b. contacting the sample with a second fluorescently-labeled binding moiety that specifically binds to a second biomarker;  
 c. detecting a first fluorescent signal from at least a portion of the labeled sample;  
 25 d. detecting a second fluorescent signal from a population of fluorescently-labeled particles, wherein the population includes a known fluorescent intensity over a fixed time; and  
 e. normalizing the first fluorescent signal to the second fluorescent signal, thereby quantifying the second biomarker, wherein the normalizing includes using a device comprising software capable of comparing the first and second fluorescent signal.

**[0152]** There is thus provided according to an embodiment of the present invention, a method for performing a microfluidic chemical reaction on a sample, the method comprising;

- 30 a) combining the sample with at least one composition comprising at least one detector moiety adapted to react with said sample to form a reaction product; and  
 35 b) detecting said at least one detector moiety to provide an indication of said reaction product.

**[0153]** There is thus provided according to an embodiment of the present invention, a method for performing a chemical reaction on a microfluidic scale, the method comprising;

- 40 a) receiving a sample into a microfluidic element;  
 b) combining said sample with at least one composition comprising at least one detector moiety disposed in said microfluidic element; and  
 45 c) detecting said at least one detector moiety.

**[0154]** There is thus provided according to an embodiment of the present invention, a method for performing a chemical reaction on a microfluidic scale, the method comprising;

- 50 a) reacting a sample with at least one composition disposed in a microfluidics element to form a reaction product in said microfluidics element; and  
 b) detecting at least one detector moiety adapted to react with said sample to provide an indication of appearance of said reaction product thereby providing the indication of the chemical reaction.

**[0155]** There is thus provided according to an embodiment of the present invention, a method for performing a chemical reaction, the method comprising;

- 55 a) receiving a first reactant in a microfluidics disposable element;  
 b) combining said first reactant with at least one composition comprising at least one detector moiety to form a

reaction product, said detector moiety being adapted to react with a reaction product; and  
c) providing an indication of said chemical reaction responsive to said detector moiety.

5 [0156] There is thus provided according to an embodiment of the present invention, a method for performing a chemical reaction, the method comprising;

- 10 a) receiving a first reactant in a microfluidics disposable element;  
b) combining said first reactant with at least one composition comprising at least one detector moiety to form a reaction product, said detector moiety being adapted to react with the first reactant product; and  
c) providing an indication of said chemical reaction responsive to said detector moiety.

[0157] There is thus provided according to an embodiment of the present invention, a method for performing a rapid detection of a chemical entity, the method comprising;

- 15 a) receiving a sample comprising a first reactant in a disposable element;  
b) reacting said sample with a composition disposed in said disposable element to form at least one reaction product; and  
c) detecting said disappearance of said first reactant responsive to activation of a reporter element disposed in said disposable element thereby providing rapid detection of said chemical entity.

20 [0158] There is thus provided according to an embodiment of the present invention, a method for performing a rapid detection of a chemical entity, the method comprising;

- 25 a) receiving a said sample comprising the chemical entity into a disposable element;  
b) reacting at least part of the sample with at least one composition disposed in said disposable element to form at least one reaction product; and  
c) detecting at least one detector moiety in said at least one composition responsive to said reacting step thereby detecting said chemical entity.

30 [0159] There is thus provided according to an embodiment of the present invention, a method for performing a rapid detection of a chemical entity, the method comprising;

- 35 a) receiving a sample comprising a first reactant in a disposable element;  
b) combining said sample with at least one composition disposed in said disposable element to form a reaction product; and  
c) detecting at least one detector moiety disposed in said disposable element, said at least one detector moiety being adapted to react with a reaction product thereby providing rapid detection of the chemical entity.

40 [0160] There is thus provided according to an embodiment of the present invention, a method for performing a rapid detection of a chemical entity, the method comprising;

- 45 a) receiving a first reactant in a sample into a disposable element;  
b) reacting at least one composition with at least part of said sample to form a reaction product; and  
c) detecting at least one reporter element disposed in said disposable element, said at least one reporter element being adapted to provide a rapid indication said of reaction product thereby providing rapid detection of the chemical entity.

50 [0161] There is thus provided according to an embodiment of the present invention, a method for performing a rapid detection of a chemical entity, the method comprising;

- 55 a) receiving a first reactant in a sample into a microfluidics element;  
b) reacting at least part of said sample with at least one composition disposed in said microfluidics element to form a reaction product; and  
c) detecting at least one reporter element disposed in said microfluidics element, said at least one reporter element being adapted to provide a rapid indication of disappearance of said chemical entity thereby providing rapid detection of the chemical entity.

[0162] According to an embodiment of the present invention, the microfluidics method is configured to provide the

rapid indication with one hour.

**[0163]** According to another embodiment of the present invention, the microfluidics method is configured to provide the rapid indication with thirty minutes.

**[0164]** According to another embodiment of the present invention, the microfluidics method is configured to provide the rapid indication with fifteen minutes.

**[0165]** According to another embodiment of the present invention, the microfluidics method is configured to provide the rapid indication with ten minutes.

**[0166]** According to another embodiment of the present invention, the microfluidics method is configured to provide the rapid indication with five minutes.

**[0167]** According to another embodiment of the present invention, the microfluidics method is configured to provide the rapid indication with one minute.

**[0168]** According to another embodiment of the present invention, the microfluidics method is configured to provide the rapid indication with thirty seconds.

**[0169]** According to another embodiment of the present invention, the microfluidics method is configured to provide the rapid indication with ten seconds.

**[0170]** According to another embodiment of the present invention, the microfluidics method is configured to provide the rapid indication with one second.

**[0171]** There is thus provided according to an embodiment of the present invention, a microfluidics method for performing a rapid detection of a biological entity, the method comprising;

- a) receiving a sample comprising a biological entity into a disposable element comprising a reactant;
- b) reacting said sample with said reactant to form a reaction product; and
- c) detecting at least one reporter element in said disposable element thereby providing a rapid indication of disappearance of said reactant so as to provide rapid detection of the biological entity.

**[0172]** There is thus provided according to an embodiment of the present invention, a microfluidics method for performing a rapid detection of a biological entity, the method comprising;

- a) receiving a sample comprising a biological entity into a disposable element comprising a reactant;
- b) reacting said sample with said reactant to form a reaction product; and
- c) detecting at least one reporter element in said disposable element thereby providing a rapid indication of appearance of said reaction product so as to provide rapid detection of the biological entity.

**[0173]** There is thus provided according to an embodiment of the present invention, a microfluidics method for performing a rapid detection of a chemical entity, the method comprising;

- a) receiving a sample comprising a first reactant into a disposable element;
- b) combining at least part of said sample with at least one composition in said disposable element to form a reaction product;
- c) reacting at least one detector moiety, disposed in said disposable element with said reaction product; and
- d) detecting said at least one detector moiety thereby providing rapid detection of the chemical entity.

**[0174]** There is thus provided according to an embodiment of the present invention, a microfluidics method for performing a rapid detection of a chemical entity, the method comprising;

- a) a receiving a sample comprising a first reactant into a disposable element;
- b) combining said sample with at least one composition to form a reaction product; and
- c) detecting at least one reporter element, said at least one reporter element being adapted to provide a rapid indication said of reaction product thereby providing rapid detection of the chemical entity.

**[0175]** There is thus provided according to an embodiment of the present invention, a microfluidics method for performing a rapid detection of a chemical entity, the method comprising;

- a) receiving a sample comprising a first reactant into a disposable element;
- b) combining said sample with at least one composition, disposed in said disposable element, to form a reaction product; and
- c) detecting at least one reporter element adapted to provide a rapid indication of disappearance of said chemical entity thereby providing rapid detection of the chemical entity.

[0176] According to some embodiments, the sample may be liquid, according to other embodiments, the sample may be a colloid or suspension. According to further embodiments, the sample may be a solid, such as in a powder or crystal form.

[0177] The present invention will be more fully understood from the following detailed description of the preferred embodiments thereof, taken together with the drawings.

## BRIEF DESCRIPTION OF THE DRAWINGS

[0178] The invention will now be described in connection with certain preferred embodiments with reference to the following illustrative figures so that it may be more fully understood.

[0179] With specific reference now to the figures in detail, it is stressed that the particulars shown are by way of example and for purposes of illustrative discussion of the preferred embodiments of the present invention only and are presented in the cause of providing what is believed to be the most useful and readily understood description of the principles and conceptual aspects of the invention. In this regard, no attempt is made to show structural details of the invention in more detail than is necessary for a fundamental understanding of the invention, the description taken with the drawings making apparent to those skilled in the art how the several forms of the invention may be embodied in practice.

[0180] In the drawings:

Fig. 1 is a simplified schematic illustration showing an apparatus for detecting a biological condition, in accordance with an embodiment of the present invention;

Fig. 2 is a simplified flow chart of a method for detecting a biological condition, in accordance with an embodiment of the present invention;

Fig. 3 is a simplified schematic illustration showing a methodology for detecting a biological condition associated with a CD64 cell surface antigen, in accordance with an embodiment of the present invention;

Fig. 4 is a simplified flow chart of a method for detecting a biological condition associated with a CD64 cell surface antigen, in accordance with an embodiment of the present invention;

Fig 5A is a graphical output of a fluorescent detection assay of a non-activated neutrophil signature associated with the method of Figs. 3-4, in accordance with an embodiment of the present invention;

Fig 5B is a graphical output of a fluorescent detection assay of an activated neutrophil signature, associated with the method of Figs. 3-4, in accordance with an embodiment of the present invention;

Fig 5C is a graphical output of a fluorescent detection assay of a monocyte signature, associated with the method of Figs. 3-4, in accordance with an embodiment of the present invention;

Fig 5D is a graphical output of a fluorescent detection assay of a reference bead signature, associated with the method of Figs. 3-4, in accordance with an embodiment of the present invention;

Fig. 6 is a simplified schematic illustration showing a methodology for detecting a biological condition associated with a plasma protein, in accordance with an embodiment of the present invention;

Fig. 7 is a simplified flow chart of a method for detecting a biological condition associated with a plasma protein, in accordance with an embodiment of the present invention;

Fig 8A is a graphical output of a fluorescent detection assay of plasma protein beads with a no target binding signature, associated with the method of Figs. 6-7, in accordance with an embodiment of the present invention;

Fig 8B is a graphical output of a fluorescent detection assay of an unbound tagged antibody signature, associated with the method of Figs. 6-7, in accordance with an embodiment of the present invention;

Fig 8C is a graphical output of a fluorescent detection assay of plasma protein target beads with target binding, associated with the method of Figs. 6-7, in accordance with an embodiment of the present invention;

Fig 8D is a graphical output of a fluorescent detection assay of a reference bead signature, associated with the

method of Figs. 6-7, in accordance with an embodiment of the present invention;

5 Fig. 9 is a simplified schematic illustration showing another microfluidics apparatus for detecting a chemical entity, in accordance with an embodiment of the present invention;

Fig. 10 is another simplified flow chart of a method for detecting a chemical entity, in accordance with an embodiment of the present invention;

10 Fig. 11 is a simplified schematic illustration showing a methodology for detecting and quantifying glucose, protein and albumin in a serum sample, in accordance with an embodiment of the present invention;

Fig. 12A is a simplified three dimensional front view of a reader assembly and cartridge for detecting a biological condition, in accordance with an embodiment of the present invention;

15 Fig. 12B is a simplified three dimensional inner front view of a reader assembly for detecting a biological condition, in accordance with an embodiment of the present invention;

Fig. 13A is an outer side view of a cartridge assembly, in accordance with an embodiment of the present invention;

20 Fig. 13B is an inner side view of a cartridge assembly, in accordance with an embodiment of the present invention;

Figs. 14A-14O show a sequence of process events in a cartridge assembly, in accordance with an embodiment of the present invention;

25 Fig. 15 is a schematic illustration of a micro flow spectrometer reading, in accordance with an embodiment of the present invention;

Fig. 16 is a simplified blown up diagram of an optical reader assembly for detecting a biological condition, in accordance with an embodiment of the present invention;

30 Fig. 17 is another simplified blown up diagram of a photomultiplier tube of the optical reader assembly for detecting a biological condition, in accordance with an embodiment of the present invention;

35 Fig. 18A shows a reader optics assembly, a cartridge handling unit, and a forward scatter detection unit, in accordance with an embodiment of the present invention;

Fig. 18B shows a right side view of a reader optics assembly, in accordance with an embodiment of the present invention;

40 Fig. 18C shows a left side view of a reader optics assembly, in accordance with an embodiment of the present invention;

Fig. 18D is a forward scatter detection assembly, in accordance with an embodiment of the present invention;

45 Fig. 18E is a side view of the forward scatter detection assembly, in accordance with an embodiment of the present invention;

Fig. 19A shows a cutaway view of a reader assembly, in accordance with an embodiment of the present invention;

50 Fig. 19B shows an exploded right side view of a reader assembly, in accordance with an embodiment of the present invention;

Fig. 19C shows a left side blown up view of the reader assembly, in accordance with an embodiment of the present invention;

55 Fig. 19D shows a rear view of a cartridge handling unit (CHU), in accordance with an embodiment of the present invention;

Fig. 19E shows a front view of a cartridge handling unit (CHU), in accordance with an embodiment of the present invention;

5 Fig. 19F is a simplified illustration of a disposable cartridge of the system of Fig. 12A, in accordance with an embodiment of the present invention;

Fig. 20 is a simplified illustration of a disposable cartridge for rapid determination of a medical condition, in accordance with an embodiment of the present invention;

10 Fig. 21A is a simplified schematic illustration of an optical arrangement of a reader optics assembly, in accordance with an embodiment of the present invention;

Fig. 21B is another simplified schematic illustration of optical arrangement of a reader optics assembly, in accordance with an embodiment of the present invention;

15 Fig. 22A is a schematic representation of one example of multi-wavelength excitation in the optical unit of Fig. 21A or 21B, in accordance with an embodiment of the present invention;

20 Fig. 22B shows a graphical output of transmission as a function of wavelength for a dichroic filter of Fig. 21B, employing the multi-wavelength excitation of Fig. 22A, in accordance with an embodiment of the present invention;

Fig. 22C is a schematic representation of part of the optical unit employing multi-wavelength excitation of Fig. 22A and the dichroic filter of Fig. 21A, in accordance with an embodiment of the present invention.

25 Fig. 23A is a schematic view of a sampling cartridge of the system of Fig. 1, in accordance with an embodiment of the present invention;

Fig. 23B shows a schematic view of disposable cartridge in flow-cytometer device, in accordance with an embodiment of the present invention;

30 Fig. 24 is a simplified flowchart of a method for rapid determination of a medical condition, in accordance with an embodiment of the present invention;

35 Fig. 25 is a three-dimensional graph showing the optical output over time of reference beads (RM) relative to a sample from a human patient (PMN), in accordance with an embodiment of the present invention; and

Figs. 26A-26C show graphs of optical outputs over time of the reference beads and the sample from a human patient, in accordance with an embodiment of the present invention.

40 **[0181]** In all the figures similar reference numerals identify similar parts.

## **DETAILED DESCRIPTION OF PREFERRED EMBODIMENTS**

45 **[0182]** In the detailed description, numerous specific details are set forth in order to provide a thorough understanding of the invention. However, it will be understood by those skilled in the art that these are specific embodiments and that the present invention may be practiced also in different ways that embody the characterizing features of the invention as described and claimed herein.

**[0183]** International patent application publication no. WO2011/128893 to Kasdan et al., describes a device, system and method for rapid determination of a medical condition and is incorporated herein by reference.

50 **[0184]** The microfluidic cartridges of the present invention may be any suitable cartridge as shown in the figures or any of the prior art cartridges described or cited herein, such as, but not limited to, those described in USD669191 S1, US20120266986 A1, EP1846159 A2, US2012275972, WO11094577A, US2007292941A and EP1263533 B1.

**[0185]** Reference is now made to Fig. 1, which is a simplified schematic illustration showing an apparatus 100 for detecting a biological condition, in accordance with an embodiment of the present invention.

55 **[0186]** Apparatus 100 is a kit comprising a cartridge 102 and a number of chemical/biochemical reactants termed herein, treatment compositions. The treatment compositions are adapted to react, at least in part, with biological specimen, such as a body specimen, to be introduced to the apparatus. The body specimen may be a bodily fluid such as, but not limited to, blood, serum, plasma, urine, saliva, cerebrospinal fluid (CSF), serous fluid, peritoneal fluid and synovial fluid.

Additionally or alternatively, the body specimen may be a solid such as a hair, a tooth part, a bone part or a piece of cartilage.

[0187] Apparatus 100 comprises a specimen receiving element 118, adapted to transfer the specimen to a sample composition chamber 104. The sample composition chamber comprises on or more transfer elements 105, adapted to transfer the specimen from the sample composition chamber to one or more other locations in the cartridge. In the non-limiting example shown in Fig. 1, transfer element 105 is a conduit in fluid connection with a treatment chamber 112. These conduits may appear in other figures herein, and are, in some cases, microfluidic channels. The microfluidic channels may have, in some embodiments, a cross-section of 0.1 to 2 mm<sup>2</sup>.

[0188] Additionally, the cartridge comprises a number of treatment composition chambers 106, 108, 110, adapted to respectively house a corresponding number of treatment compositions 120, 122, 124. These chambers are also termed "blisters" herein. These treatment compositions may be liquid, solid or combinations thereof. Apparatus 100 is typically sold commercially as a kit with the treatment compositions disposed therein. In some cases, the kit may be adapted for a one-off test and may be a disposable kit. In other cases, the kit may be re-used. A re-usable kit may be adapted to receive additional external compositions (not shown) or may have a plurality of treatment compositions, wherein only a portion is used for each test.

[0189] The apparatus may be constructed and configured such that the treatment composition comprises proteins attached to a surface, such as to beads. A plurality of beads or other structural elements with proteins attached to their surfaces by any one or more of the following methodologies:-

- simple attachment such as by adsorption via electrostatic or hydrophobic interactions with the surface, entrapment in immobilized polymers, etc.
- covalent bonding of the protein to the bead surface
- biological recognition (e. g., biotin/streptavidin).
- requires two steps: a first layer is formed by silane chemistry such that the surface presents a reactive group (e. g., epoxy, amino, thiol, etc.), and a second layer (e. g., the protein to be immobilized or a linker molecule) is covalently attached via the immobilized reactive groups.
- covalent attachment to functionalized polymer coatings on the interior of the device or linkage to the free end of a self-assembled monolayer (SAM) on a gold surface.

[0190] The reaction type may include any one or more of antigen-antibody binding, sandwich (such as antibody-antigen-antibody), physical entrapment, receptor-ligand, enzyme-substrate, protein-protein, aptamers, covalent bonding or biorecognition.

[0191] Cartridge 102 further comprises at least one transfer element 107, 109, 111 in fluid communication with each respective of treatment composition chamber, each transfer element also being in fluid communication with treatment chamber 112.

[0192] Various methodologies for transferring the contents of the treatment composition chambers and the sample composition chamber via the transfer elements to the treatment chamber may be employed, some of which are known in microfluidics technologies. These include air blowing, suction, vacuuming, mechanical transfer, pumping and the like.

[0193] Cartridge 102 further comprises at least one transfer element 113 in fluid communication with treatment chamber 112 and with an evaluation chamber 114.

[0194] Optionally, evaluation chamber 114 is further in fluid communication with a transfer element 115, adapted to remove the contents of the evaluation chamber for disposal outside the cartridge. Alternatively, the evaluation chamber may have no external disposal means.

[0195] Table 1 shows some representative applications of apparatus 100 and methods of the present invention.

Table 1 Some Biological Applications of the apparatus and methods of this invention.

Application	Type of Test	Relevant Figures in this invention	Typical Prior Art Laboratory Turnaround time (TAT)-see references	This invention Turnaround time (TAT)	References
Application #1 - CD64 Infection & Sepsis	Surface Marker	Figs. 1-2 and 3-5D	4 hours	10 minutes	US 8,116,984, Davis, BH et al., (2006)

EP 3 508 848 A1

(continued)

Application	Type of Test	Relevant Figures in this invention	Typical Prior Art Laboratory Turnaround time (TAT)-see references	This invention Turnaround time (TAT)	References
1 - Fetal Hemoglobin Test	Plasma Protein	Figs. 1-2 and 6-8D	4 hours	10 minutes	Dziegiel et al. (2006)
2 - Low Platelet Count	Surface Marker	Figs. 1-2 and 3-5D	4 hours	10 minutes	Segal, H. C., et al. (2005):
3 - Resolving BLAST Flag for hematology Lab	Surface Marker	Figs. 1-2 and 3-5D	4 hours	10 minutes	Guerti, K., et al.
4 - CD34 Stem Cell Enumeration Assay	Surface Marker	Figs. 1-2 and 3-5D	4 hours	10 minutes	Sutherland et al. (1996)
5 - Platelets Activation Assay CD62	Surface Marker	Figs. 1-2 and 3-5D	4 hours	10 minutes	Graff et al. (2002) Divers, S. G., et al. (2003)
6 - D-dimer (Bead based protein)	Plasma Protein	Figs. 1-2 and 6-8D	4 hours	10 minutes	Stein et al. (2004) Rylatt, D. B., et al. (1983):
7 - Chorioamnioitis CD64	Surface Marker	Figs. 1-2 and 3-5D	4 hours	10 minutes	Hillier et al. (1988)
8 - CD20 Cell Quantitation (Therapy Monitoring)	Surface Marker	Figs. 1-2 and 3-5D	4 hours	10 minutes	Rawstron et al. (2001) Cheson et al. (1996)
9 - CD52 Cell quantitation (Therapy Monitoring)	Surface Marker	Figs. 1-2 and 3-5D	4 hours	10 minutes	Rawstron et al. (2001)
10 - Circulating Tumor Cells	Surface Marker	Figs. 1-2 and 3-5D	4 hours	10 minutes	Cristofanilliet al. (2004)
11 - Reticulated Platelet Assay	Surface Marker	Figs. 1-2 and 3-5D	4 hours	10 minutes	Matic et al. (1998) Ault et al (1993) Wang et al. (2002)
12 - Bacteria Detection in platelet packs			4 hours	10 minutes	Blajchman et al (2005) McDonald et al. (2005)
13 - Platelet Associated Antibodies	Surface Marker	Figs. 1-2 and 3-5D	4 hours	10 minutes	Michelson (1996)
14 - Residual Leukocyte Count in blood products	Surface Marker	Figs. 1-2 and 3-5D	4 hours	10 minutes	Bodensteiner, (2003)
15 - CD4 HIV AIDS	Surface Marker	Figs. 1-2 and 3-5D	4 hours	10 minutes	Rodriguez (2005). Dieye et al. (2005)

(continued)

Application	Type of Test	Relevant Figures in this invention	Typical Prior Art Laboratory Turnaround time (TAT)-see references	This invention Turnaround time (TAT)	References
16 - Leukemia Panels - Very complex	Surface Marker	Figs. 1-2 and 3-5D	4 hours	10 minutes	Drexler et al (1986)
17 - Bladder Cancer Screening in Urine - Urine sample	Surface Marker	Figs. 1-2 and 3-5D	4 hours	10 minutes	Ramakumar et al (1999) Lotan et al. (2009)
18 - HLA DR Sepsis and Immunosuppression	Surface Marker	Figs. 1-2 and 3-5D	4 hours	10 minutes	Hershman et al. (2005) Perry et al (2003)
19 - RECAF Protein for Canine and other Cancers	Plasma Protein	Figs. 1-2 and 6-8D	4 hours	10 minutes	Moro et al. (2005).
20 - CytImmuno - Cervical Screening			4 hours	10 minutes	Hilfrich et al. (2008)
21 - Procalcitonin (Bead Based Protein) + Feasibility	Plasma Protein	Figs. 1-2 and 6-8D	4 hours	10 minutes	Assicot et al. (1993) Christ-Crain et al. (2004)

**[0196]** Reference is now made to Fig. 2, which is a simplified flow chart 200 of a method for detecting a biological condition, in accordance with an embodiment of the present invention.

**[0197]** It should be understood that each of the steps of the method may take a predetermined period of time to perform, and in between these steps there may be incubation and/or waiting steps, which are not shown for the sake of simplicity.

**[0198]** In a sample transferring step 202, a sample, such as a bodily specimen is transferred from outside apparatus 100 via receiving element 118 into sample composition chamber 104. According to some embodiments, the volume of the specimen or sample is less than 200  $\mu\text{L}$ , less than 100  $\mu\text{L}$ , less than 50  $\mu\text{L}$ , less than 25  $\mu\text{L}$  or less than 11  $\mu\text{L}$ .

**[0199]** Thereafter, treatment composition 120 is transferred via transfer element 107 to the treatment chamber in a composition transfer step 204. In some cases, there may be a treatment composition or liquid (not shown) disposed in the treatment chamber.

**[0200]** Depending on the nature of the treatment composition and sample/specimen type, there may be a requirement to mix or agitate the treatment chamber contents in an optional mixing step 206. This may be performed by using a small stir-bar (not shown) disposed in the chamber. Additionally or alternatively, this may be effected by the fluid dynamics of kit. Additionally or alternatively, stirbars may be disposed in any of the other chambers in the apparatus.

**[0201]** The sequence of transfer of the various treatment compositions may be important to the reaction sequence and is typically predefined. Steps 204-206 may be performed, for example on treatment composition chamber 106, thereafter on treatment composition chamber 108 and thereafter on treatment composition chamber 110. In some cases, some of these steps may be performed concurrently.

**[0202]** In a checking step 208, it is ascertained whether all the compositions required for the sample treatment have been transferred to the treatment chamber. If any compositions remain, then steps 204-206 are performed on the subsequent treatment composition chamber(s). If no further treatment compositions require transfer, then the sample/specimen is transferred from chamber 104 into the treatment chamber.

**[0203]** Thereafter, in a second sample transfer step 210, the sample is transferred from the sample composition chamber into the treatment chamber.

**[0204]** According to some embodiments, step 210 may be performed before steps 204-208.

**[0205]** If required, an optional mixing step 212 to the contents of the treatment chamber may be performed.

**[0206]** In a transferring step 214, the contents of the treatment chamber are transferred to the evaluation chamber.

**[0207]** The evaluation chamber 114 is configured and constructed for one or more evaluation steps 216. These may

include any combination or permutation of the following:

- a) transfer of radiation there-through,
- b) impinging radiation thereupon;
- 5 c) detecting reflected and/or refracted radiation,
- d) detecting emitted radiation;
- e) capturing one or more images thereof;
- f) performing image analysis on the captured images;
- g) measuring electrical characteristics of the treated specimen;
- 10 h) impinging sonic energy thereon;
- i) detecting sonic energy therefrom; and
- j) analyzing the outputs of any one or more of the above steps.

15 **[0208]** According to some embodiments, the cartridge is introduced into a system as described in International patent application publication no. WO2011/128893, to Kasdan et al., incorporated herein by reference.

**[0209]** The results of the evaluation step are then outputted in a results outputting step 218.

**[0210]** According to some embodiments; the apparatus may have on-board means for showing a result, such as a colorimetric strip (not shown). Additionally or alternatively, the results are displayed in a display unit, separate and remote from apparatus 100.

20 **[0211]** The time required to complete an assay using apparatus 100 varies depending on a number of factors, with non-limiting examples that include described herein. In some embodiments, the time required to complete an assay is from about 0.5 to 100 minutes. In other embodiments, the time required to complete an assay is from about 1 to 20 minutes. In still other embodiments, the time required to complete an assay is from about 1 to 10 minutes. In some examples, the time required to complete an assay is from about 1, 2, 3, 4, 5, 6,7, 8, 9, 10,15, 20,25, 30, 35,40, 50, 60,

25 80, or 100 minutes.  
**[0212]** Reference is now made to Fig. 3, which is a simplified schematic illustration showing a methodology 300 for detecting a biological condition associated with a CD64 cell surface antigen, in accordance with an embodiment of the present invention.

30 **[0213]** According to some embodiments, the method is carried out in the apparatus shown in Fig. 1 and as described herein. A biological specimen, such as a blood sample, is aspirated via specimen receiving element 118 to sample composition chamber 104, and then to treatment chamber 112. The sample is typically of a volume in the range of 10-200  $\mu$ L.

35 **[0214]** The blood sample is typically whole blood recently removed from a patient. The whole blood comprises mainly red blood cells (also called RBCs or erythrocytes), platelets and white blood cells (also called leukocytes), including lymphocytes and neutrophils. Increased number of neutrophils, especially activated neutrophils are normally found in the blood stream during the beginning (acute) phase of inflammation, particularly as a result of bacterial infection, environmental exposure and some cancers.

40 **[0215]** A cocktail 304 comprising antibodies to CD64 and antibodies to CD163 is introduced to the treatment chamber (see Davis et al. (2006)). Each antibody type is typically tagged by a specific fluorescent tag. The fluorescent tag is designed, in some cases, to be activated when the antibody binds to its antigen. In other cases, it is always active.

**[0216]** The contents of the chamber are incubated and/or mixed as is required to bind the activated blood neutrophils with the CD64 tagged antibody (also called a marker) to form activated neutrophils with CD64 marker 310, and/or monocyte with a CD64 tagged antibody and a CD163 tagged antibody 312. Lymphocytes with no markers 314 are present in the contents, as well as unaffected RBCs 316.

45 **[0217]** Thereafter, a lysis reagent or diluent 306 is introduced into treatment chamber 112. In the case of a lysis reagent, it is adapted to lyse red blood cells to form lysed red blood cells 324. Additionally, reference/calibration beads 308 are added to the treatment chamber. These are used to calibrate the outputs, as is explained with reference to Figs. 5A-5D hereinbelow.

50 **[0218]** CD64 (Cluster of Differentiation 64) is a type of integral membrane glycoprotein known as an Fc receptor that binds monomeric IgG-type antibodies with high affinity. Neutrophil CD64 expression quantification provides improved diagnostic detection of infection/sepsis compared with the standard diagnostic tests used in current medical practice.

**[0219]** CD163 (Cluster of Differentiation 163) is a human protein encoded by the CD163 gene. It has also been shown to mark cells of monocyte/macrophage lineage.

55 **[0220]** Reference is now made to Fig. 4, which is a simplified flow chart 400 of a method for detecting a biological condition associated with a CD64 cell surface antigen, in accordance with an embodiment of the present invention.

**[0221]** According to some embodiments, the method is carried out in the apparatus shown in Fig. 1 and as described herein. In a first transferring step 402, a biological specimen, such as a blood sample is aspirated via specimen receiving element 118 to sample composition chamber 104 and then to the treatment chamber 112. The sample is typically of a

volume in the range of 10-200  $\mu$ L.

**[0222]** In an addition step 404, a cocktail of tagged antibodies to CD64 and to CD163 is added to the treatment chamber 112 and is mixed and incubated with the blood sample. In the incubation phase of this step, the antibodies bind activated neutrophils with CD64 marker 310, and/or monocytes activated with a CD64 tagged antibody and a CD163 tagged antibody 312.

**[0223]** In a lysis reagent addition step 406, the lysis reagent is added to the treatment chamber and thereby lyses at least some of the RBCs in the chamber.

**[0224]** At any suitable time, typically following lysis step 406, reference beads are added to the contents of the treatment chamber in a reference bead adding step 408.

**[0225]** After a predefined period of time, an analysis step 410 is performed to analyze the fluorescent emission signatures from the contents. This is described in further detail with reference to Figs. 5A-5D. According to some examples, the evaluation chamber 114 is constructed and configured to allow cells to pass through a reading zone 130 such that each cell passing therethrough is analyzed individually.

**[0226]** Reference is now made to Fig 5A, which is a graphical output of a fluorescent detection assay of a non-activated neutrophil signature 500 associated with the method of Figs. 3-4, in accordance with an embodiment of the present invention. The non-activated tagged neutrophils each emit a signal 502 at wavelength  $W_1$  of an intensity  $I_1$ .

**[0227]** Fig 5B shows a graphical output of a fluorescent detection assay of an activated neutrophil signature 510, associated with the method of Figs. 3-4, in accordance with an embodiment of the present invention. Each activated tagged neutrophil emits an activated neutrophil signature 512 at wavelength  $W_1$  of an intensity  $I_2$ . Typically  $I_2$  is greater than  $I_1$ . In some cases the difference in signatures 512 and 510 may be detected by an image analysis, a fluorescent emission radiation count or by other qualitative or quantitative methods known in the art. The current example is not meant to be limiting.

**[0228]** Turning to Fig 5C, there can be seen a graphical output of a fluorescent detection assay of a monocyte signature 520, associated with the method of Figs. 3-4, in accordance with an embodiment of the present invention. The monocyte signature comprises a first signal 522 at a first wavelength  $W_1$  of an intensity  $I_3$  and a second signal 524 at a second wavelength  $W_2$  of an intensity  $I_4$ .

**[0229]** Fig 5D shows a graphical output of a fluorescent detection assay of a reference bead signature 530, associated with the method of Figs. 3-4, in accordance with an embodiment of the present invention. The reference bead signature comprises a first signal 532 at a first wavelength  $W_1$  of an intensity  $I_1$  (similar or equal to non-activated tagged neutrophils' signal 502) and a second signal 534 at a second wavelength  $W_3$  of an intensity  $I_5$ .

**[0230]** This methodology enables the identification and quantification of activated neutrophils by intensity of signature 512 of the CD64 tag. Monocytes are identified by the double signal signature 522, 524, acting as a positive control. Reference beads are identified by the unique signal 534 at wavelength  $W_3$ . The intensity of signal 532 at wavelength  $W_1$  provides a reference level of the CD64 tag for the comparison of intensity of 512 of the neutrophils.

**[0231]** Lymphocytes with no markers 330 (Fig. 3) act as a negative control and should provide no fluor signature, but may be detected by their scattering or other characteristics. Further details of some embodiment of this assay procedure are described in US 8,116,984 and in Davis, BH et al., (2006).

**[0232]** Reference is now made to Fig. 6, which is a simplified schematic illustration showing a methodology 600 for detecting a biological condition associated with a plasma protein, in accordance with an embodiment of the present invention;

**[0233]** According to some embodiments, the method is carried out in the apparatus shown in Fig. 1 and as described herein. A biological specimen, such as a blood sample 602, is aspirated via specimen receiving element 118 to sample composition chamber 104, and then to treatment chamber 112. The sample is typically of a volume in the range of 10-200  $\mu$ L.

**[0234]** The blood sample is typically whole blood recently removed from a patient. The whole blood comprises mainly red blood cells (also called RBCs or erythrocytes), platelets and white blood cells, including lymphocytes and neutrophils. The blood sample contains at least one protein target antigen. Beads covered in protein antibodies 604 are prepared, for example in accordance with Bangs Laboratories Product Data Sheet 854 procedure for Flow Cytometry Protein G Antibody Binding Beads catalog number 554..

**[0235]** Beads 604 are introduced to treatment chamber 112 and the blood sample 602 is also introduced. Thus at this stage of the treatment, there are some beads which have bound the (plasma) protein target 612, some beads which remain without any bound protein target antigen 610, unaffected white blood cells 614, unaffected platelets 616 and unaffected RBCs 618.

**[0236]** Each antibody type is typically tagged by a specific fluorescent tag. The fluorescent tag is designed, in some cases, to be activated when the antibody binds to its antigen. The contents of the chamber are incubated and/or mixed as is required to induce the antigen-antibody binding.

**[0237]** Thereafter, a plasma protein fluor tagged antibody composition 606 is added to the chamber and mixed/incubated, thereby forming plasma protein captured on antibody beads with fluor marker 620, as well as unbound beads

619, similar or identical to unbound beads 610. Additionally, unaffected white blood cells 622 similar or identical to 614, unaffected platelets 624, similar or identical to 616 and unaffected RBCs 626, similar or identical to 618.

5 [0238] Additionally, reference/calibration beads 608 are added to the treatment chamber. These are used to calibrate the outputs, as is explained with reference to Figs. 8A-8D hereinbelow. The plasma protein captured on antibody beads with fluor marker 628 (similar or identical to 620), and the other components unbound beads 629 (similar or identical to 619), unaffected white blood cells 630 (similar or identical to 622), unaffected platelets 624 (similar or identical to 624) and reference beads 636 (similar or identical to 608) are now ready for evaluation in accordance with the method of Fig. 7 described in further detail hereinbelow.

10 [0239] Fig. 7 shows a simplified flow chart of a method 700 for detecting a biological condition associated with a plasma protein, in accordance with an embodiment of the present invention.

[0240] According to some embodiments, the method is carried out in the apparatus shown in Fig. 1 and as described herein. In a first transferring step 702, a biological specimen, such as a blood sample is aspirated via specimen receiving element 118 to sample composition chamber 104 and then on to treatment chamber 112. The sample is typically of a volume in the range of 10-200  $\mu$ L.

15 [0241] In an addition step 704, a beads covered in plasma protein antibody 604 are added to the treatment chamber 112 and is incubated with the blood sample. In the incubation phase of this step, the antibodies on the beads bind some or all of the protein target antigen forming bound plasma protein on antibody beads 612.

[0242] In a plasma protein fluor tagged antibody addition step 708, plasma protein fluor tagged antibody 606 is added to the treatment chamber.

20 [0243] At any suitable time, typically following addition step 706, reference beads are added to the contents of the treatment chamber in a reference bead adding step 708.

[0244] After a predefined period of time, an analysis step 710 is performed to analyze the fluorescent emission signatures from the contents. This is described in further detail with reference to Figs. 8A-8D. According to some examples, the evaluation chamber 114 is constructed and configured to allow cells to pass through a reading zone 130 such that 25 each cell passing therethrough is analyzed individually.

[0245] Reference is now made to Fig 8A, which is a graphical output of a fluorescent detection assay of plasma protein beads with a no target binding signature 800, associated with the method of Figs. 6-7, in accordance with an embodiment of the present invention. The plasma protein target beads with no binding of target antigen 604 each emit a signal 802 at wavelength  $W_1$  of an intensity  $I_1$ .

30 [0246] Reference is now made to Fig 8B, which is a graphical output of a fluorescent detection assay of an unbound tagged antibody signature 810, associated with the method of Figs. 6-7, in accordance with an embodiment of the present invention.

[0247] Each unbound tagged target antibody 606 emits an unbound tagged target antibody signature 810 at wavelength  $W_2$  of an intensity  $I_2$ .

35 [0248] Fig 8C is a graphical output of a fluorescent detection assay of plasma protein target beads with target binding signature 820, associated with the method of Figs. 6-7, in accordance with an embodiment of the present invention.

[0249] Signature 820 comprises a first signal 822 at a first wavelength  $W_1$  of an intensity  $I_3$  and a second signal 824 at a second wavelength  $W_2$  of an intensity  $I_4$ . Typically  $I_4$  is greater than  $I_2$ . In some cases the difference in signatures 812 and 810 may be detected by an image analysis, a fluorescent emission radiation count or by other qualitative or 40 quantitative methods known in the art. The current example is not meant to be limiting.

[0250] Fig 8D is a graphical output of a fluorescent detection assay of a reference bead signature 830, associated with the method of Figs. 6-7, in accordance with an embodiment of the present invention.

[0251] The reference bead signature comprises a first signal 832 at a first wavelength  $W_2$  of an intensity  $I_5$  (similar to unbound tagged target antibody 606 that emits an unbound tagged target antibody signature 810 at wavelength  $W_2$ ) and a second signal 834 at a second wavelength  $W_3$  of an intensity  $I_6$ .

45 [0252] In summary of analysis step 710 (Fig. 7), the cells may be passed through reading zone 710 individually. Beads 604 without bound target protein are identified by the presence of target bead fluor signal 802 at  $W_1$ . The overall level of fluorescence determines the level of protein in the sample. Beads with bound target protein emit signature 820 both the bead fluor signal  $W_1$ , 822 (similar or identical to 802) and sandwich fluor tag  $W_2$ , 824, as is shown in Fig8C.

50 [0253] Reference beads 608 are identified by a unique fluor  $W_3$  signal 834. The level/intensity of  $W_2$  in the plasma protein target beads with target binding signature 820 is compared to that of first signal 832 at a first wavelength  $W_2$  of an intensity  $I_5$  of the reference beads to determine the overall level of target protein concentration in the sample.

**EXAMPLES****EXAMPLE 1**

5 Application No. 1 - CD64 Infection & Sepsis

10 **[0254]** A cartridge 102 (Fig. 1) is prepared for receiving a blood sample. The cartridge comprises a number of treatment composition chambers 106, 108, 110, adapted to respectively house a corresponding number of treatment compositions 120, 122, 124. These compositions are described in further detail in US 8,116,984 and in Davis, BH et al., (2006), incorporated herein by reference. In brief, Reagent A comprises a mixture of murine monoclonal antibodies (contains buffered saline), Reagent B - 10X Concentrated Trillium Lyse solution (contains ammonium chloride), Reagent C - suspension of 5.2  $\mu\text{m}$  polystyrene beads labeled with Starfire Red and fluorescein isothiocyanate (FITC), (contains < 0.1% sodium azide and 0.01% Tween 20).

15 **[0255]** In a sample transferring step 202 (Fig. 2), a 10 $\mu\text{L}$  blood sample, is transferred from outside apparatus 100 via receiving element 118 into sample composition chamber 104, and then on to treatment chamber 112 in a transferring step 214.

**[0256]** An antibody composition (Reagent A) 120 comprising CD64 antibodies is transferred via transfer element 107 to the treatment chamber in a composition transfer step 204.

20 **[0257]** These two steps combined with mixing step 206 take around four minutes using cartridge 102 of the present invention.

**[0258]** A lysis buffer (Reagent B) 122 is also added and mixed with the resultant mixed composition. This step and mixing all the compositions takes around three minutes using cartridge 102 of the present invention. Reference beads (Reagent C) 308 are added to the treatment chamber.

**[0259]** The evaluation chamber 114 is configured and constructed for one or more evaluation steps 216.

25 **[0260]** According to some embodiments, the cartridge is introduced into a system as described in International patent application publication no. WO2011/128893 to Kasdan et al., incorporated herein by reference. This system has software associated therewith for computing the CD64 and CD163 indices on leukocytes.

30 **[0261]** The results of the evaluation step are then outputted in a results outputting step 218. According to this example, the time taken from the introduction of the small blood sample to obtaining an indication of sepsis is less than 15 minutes, typically around 10 minutes (see comparison of prior art and the present invention methodologies in Table 2).

**[0262]** From a user point of view, the following steps are performed:

1) The user adds drop of blood to the cartridge 102 and seals it. (10  $\mu\text{L}$  are metered out by microfluidics)

35 2) Blister A (106) is pressed, releasing 100  $\mu\text{L}$  of Reagent A. Mixing in the cartridge is controlled by the cartridge handling unit (CHU), followed by a 4-minutes incubation.

3) Blister B (108) is pressed, releasing ~250  $\mu\text{L}$  of Reagent B. Mixing in the cartridge is controlled by the CHU, followed by a 3-5-minutes incubation.

40 4) Magnetic stirbar is activated, stirring the bead suspension (Reagent C)

45 5) Blister C (110) is pressed, releasing 100  $\mu\text{L}$  of Reagent C. Mixing in the cartridge is controlled by the CHU. According to one example, Reagent A is a mixture of murine monoclonal antibodies- diluted 1:5 in buffered saline (PBS+0.5% BSA); Reagent B is a Trillium Lyse solution (at working concentration); Reagent C is a suspension of 5.2  $\mu\text{m}$  polystyrene beads labeled with Starfire Red and FITC, diluted 1:100 in PBS + 0.01% Tween 20.

6) The sample is read by the optoelectronics core, and the data is collected.

50 7) Data is analyzed automatically and result is presented.

8) The cartridge is disposed as biohazard.

55

Table 2 Comparison of Prior art methodology with the methodology of the present invention for detecting sepsis using CD64 and CD163 antibodies.

Trillium kit (FACS)- (prior art US 8,116,984, Davis, BH et al., (2006))				LeukoDx device-present invention		
Step	Description	Volume (uL)	Duration (min)	Volume (uL)	Duration (min)	comments
1	Mixing blood and antibodies	Blood-50 Abs-50	10	Blood-10 Abs-50	4	
2	Adding RBC lysis buffer	900		250	3	Might require heating the buffer to 37C
3	Incubating, Vortexing		15		3	
4	Adding normalization beads	5	Less than 1	2	Less than 1	
5	Reading		1		Less than 1	
	Total	1005	26-30 min.	312	10 min.	

EXAMPLE 2

Application No. 2 - Fetal Hemoglobin Test

**[0263]** A fetal hemoglobin test is performed using a cartridge comprising compositions as described in Dziegiel et al. (2006). The test is performed using the methodology described in Figs. 1-2 and 6-8D.

**[0264]** According to some embodiments, the cartridge is introduced into a system as described in International patent application publication no. WO2011/128893 to Kasdan et al., incorporated herein by reference. This system uses LeukoDx Software - to analyze data collected and stored in a format similar to flow cytometric listmode files. The test takes around 10-15 minutes from the introduction of the sample to receiving a result from the system.

**[0265]** It should be understood that all of the examples listed in Table 1 can be performed using the cartridge of the present invention in combination with the system of WO2011/128893. For each application, a different cartridge is prefabricated using the compositions for the assays, as described in the relevant references (Table 1). The quantities and dilutions thereof are optimized. Typically, the total sample volumes are in the range of 10 to 1000 μL, 100 to 900 μL, 200 to 800 μL, 300 to 700 μL, 400 to 600 μL, or 420 to 500 μL.

**[0266]** According to some embodiments, the volume of the treatment composition chambers 106, 108, 110 (also called blisters) is from about 1 μL to 1000 μL. According to other embodiments, the volume of the specimen is from about 10 μL to 200 μL. According to other embodiments, the volume of the specimen is about 1, 10, 20, 30, 40, 50, 60, 70, 80, 90, 100, 120, 140, 160, 180, 200, 250, 300, 350, 400, 450, or 500 μL.

**[0267]** According to some embodiments, the volume of the treatment compositions 120, 122, 124 is at most about 500 μL. According to other embodiments, the volume of the specimen is at most about 200 μL. According to other embodiments, the volume of the specimen at most about 500, 450, 400, 350, 300, 250, 200, 180, 160, 140, 120, 100, 90, 80, 70, 60, 50, 40, 30, 20, 10, or 1 μL.

**[0268]** According to some embodiments, the volume of a reactant is at least about 1 μL. According to other embodiments, the volume of the specimen is from about 10 μL. According to other embodiments, the volume of the specimen is at least about 1, 10, 20, 30, 40, 50, 60, 70, 80, 90, 100, 120, 140, 160, 180, 200, 250, 300, 350, 400, 450, or 500 μL.

**[0269]** Cartridge 102 may be constructed and configured to enable running multiplex tests on parallel microchannels.

**[0270]** One embodiment of the current design as is suitable for three blisters, representing three different treatments. These treatments could be, for example: a) Direct staining by a fluorescent antibody (or antibody fragments, Fabs); b) Lysis of RBCs and c) Adding internal controls.

**[0271]** Other embodiments disclose two-stage staining, by primary and secondary antibodies, resulting in stronger signals, adding beads (for example magnetic, metallic, polymeric, and antigen-bound beads) for selection or detection of specific cells, proteins, antibodies, auto-antibodies and other biological molecules; tissue sample disintegration cell permeabilization (allowing detection of intracellular proteins); DNA-staining (enables cell counting); RNA-staining (using thiazole orange, enables reticulocyte counts since reticulocytes can be distinguished from erythrocytes by their high content of RNA.); fluorescent staining and/or tagging by aptamers (single-stranded DNA or RNA molecules that can bind to selected targets including proteins and peptides with high affinity); adding substances for enzyme-coupled re-

actions (stored in separate blisters and mixed upon adding the reagent, for example HRP-conjugated antibodies for chemiluminescent reactions); and adding buffers for washes (note that washing steps will require further design of the cartridge).

5 **[0272]** Additionally, the present invention includes treatments on the cartridge itself, such as, but not limited to immobilized selective beads can be utilized by passing the solution back and forth on the bed to increase the capture efficiency; filters for cell size, molecule size, and ligand-bound filters (enabling washing steps and/or population selection).

10 **[0273]** The sample may also include biological tissues, which will require a further step of mechanically disintegrating the tissue sample. For example a skin biopsy: the sample is added to a dedicated port. The port is sealed, and a blister adds a liquid buffer. A dedicated bellow pushes this mixture and disintegrates the tissue either by several push-pull circles, or by pressing it through a mesh.

**[0274]** The cartridge of the present invention may also be used for food/environment safety evaluations: Food/beverage samples for bacteria detection (possibly also allergens detection) and measuring viable bacteria in an environmental sample.

15 **[0275]** According to some embodiments, the readout may comprise an optoelectronics core, which enables identification and detection of fluorescent signals.

**[0276]** The CCD in the core, used for focusing, can also be used to read chemiluminescent signals. The readout to user may also indicate where the result falls relative to reference ranges.

**[0277]** As can be seen in the Tables herein, there are a large number of applications to the systems, apparatus, cartridges and methods of the present invention and the examples described herein should not be deemed limiting.

20 **[0278]** Reference is now made to Fig. 9, which is a simplified schematic illustration showing a microfluidics apparatus 900 for detecting a chemical or biochemical entity, in accordance with an embodiment of the present invention.

25 **[0279]** Apparatus 900 is a kit comprising a cartridge 902 and a number of chemical/biochemical reactants termed herein, treatment compositions. The treatment compositions are adapted to react, at least in part, with a chemical or biological specimen 970, such as a body specimen, to be introduced to the apparatus. The body specimen may be a bodily fluid such as, but not limited to, blood, serum, plasma, urine, saliva, cerebrospinal fluid (CSF), serous fluid, peritoneal fluid and synovial fluid. Additionally or alternatively, the body specimen may be a solid such as a hair, a tooth part, a bone part or a piece of cartilage.

**[0280]** The chemical specimen may be selected, for example, from a liquid sample, a solid sample, a suspension, a colloid, a composition, an ionic solution or any other suitable sample, known in the art.

30 **[0281]** Apparatus 900 comprises a specimen receiving element 918, adapted to transfer the specimen to a sample composition chamber 904. The sample composition chamber comprises on or more transfer elements 905, adapted to transfer the specimen from the sample composition chamber to one or more other locations in the cartridge. In the non-limiting example shown in Fig. 9, transfer element 905 is a conduit in fluid connection with a treatment chamber 912 at a first end 913 thereof.

35 **[0282]** Additionally, the cartridge comprises a number of treatment composition chambers 906, 908, 919, adapted to respectively house a corresponding number of treatment compositions 920, 922, 924. These treatment compositions may be liquid, solid or combinations thereof. Apparatus 900 is typically sold commercially as a kit with the treatment compositions disposed therein. In some cases, the kit may be adapted for a one-off test and may be a disposable kit. In other cases, the kit may be re-used. A re-usable kit may be adapted to receive additional external compositions (not shown) or may have a plurality of treatment compositions, wherein only a portion is used for each test.

40 **[0283]** Cartridge 902 further comprises a gas holding compartment 901, adapted to contain air 950 and/or other gases. In some cases, the gas may be inert, such as nitrogen.

**[0284]** Each treatment composition chamber 906, 908 and 919 has at least one respective conduit 907, 909, 910 in fluid communication with treatment chamber 912.

45 **[0285]** According to one embodiment, conduits 907, 909 and 910 are disposed in parallel at fixed equal intervals to the treatment chamber.

**[0286]** According to another embodiment, conduits 907, 909 and 910 are disposed in parallel at fixed unequal intervals to the treatment chamber.

50 **[0287]** Various methodologies for transferring the contents of the treatment composition chambers and the sample composition chamber via the transfer elements to the treatment chamber may be employed, some of which are known in microfluidics technologies. These include air blowing, suction, vacuuming, mechanical transfer, pumping and the like.

**[0288]** Cartridge 902 further comprises at least one transfer element 913 in fluid communication with treatment chamber 912 and with an evaluation chamber 914.

55 **[0289]** Optionally, evaluation chamber 914 is further in fluid communication with a transfer element 915, adapted to remove the contents of the evaluation chamber for disposal outside the cartridge. Alternatively, the evaluation chamber may have no external disposal means.

**[0290]** According to some examples, the evaluation chamber 914 is constructed and configured to allow some or all of the treated samples to pass through a reading zone 930.

**[0291]** According to some embodiments, fluid transfer element 915 is fluidly connected to at least one vacuum pump or bellows 940.

**[0292]** Apparatus 900 is constructed and configured to introduce a small volume of gas into the treatment chamber, typically by activating the pump 940. Thereafter a small volume of the sample 966 is introduced into the treatment chamber. The alternating introduction of air and further small volumes of samples 964, 962, 960 may be performed a number of times.

**[0293]** According to some embodiments, the treatment chamber is constructed and configured to receive a specific treatment composition for only one small volume of sample. For example, as illustrated in the figure, composition 924 is introduced into small volume of sample 966, composition 922 is introduced into small volume of sample 964, and composition 920 is introduced into small volume of sample 962. Small volume of sample 960 remains untreated and may serve as a control.

**[0294]** According to some additional embodiments, the treatment chamber is constructed and configured to receive a specific treatment composition for all of the small volume of samples sequentially. For example, small volume of sample 966 enters the treatment chamber at first end 913 and is pulled by pump 940 to a position in fluid connectivity with conduit 907 and receives a small amount of treatment composition 920. It is then moved to a position in fluid connectivity with conduit 909 and composition 922 is introduced thereto. Thereafter, sample 966 is moved to another position in fluid connectivity with conduit 910 and composition 924 is introduced into small volume of sample 966. Thereafter small volume of sample 966 is brought via conduit 913 to reading zone 930 in the evaluation chamber.

**[0295]** The reading zone is constructed and configured to enable a number of different detection mechanisms to be effected. Some non-limiting examples of detection mechanisms include:

- image capture
- image analysis
- optical detection
- kinetic study detection
- sound detection
- volume detection
- gas detection
- chromatography

**[0296]** The optical detection may be human visual detection, human microscopic examination, or automated machine optical detection. The optical detection may involve one or more of detecting at least optical output signal. The output signal may be selected from a transmitted signal, an absorbed signal, a reflected signal, a refracted signal or combinations thereof.

**[0297]** The optical detection may use optical elements and systems external to the cartridge. These may include, for example, optical microscopes, image analyzers, electron microscopes or any other systems known in the art.

**[0298]** After the evaluation has been performed, the small volume of sample may be retained in the chamber or discarded via conduit 915.

**[0299]** Reference is now made to Fig. 10, which is a simplified flow chart 1000 of a method for detecting a chemical or biochemical entity, in accordance with an embodiment of the present invention.

**[0300]** It should be understood that each of the steps of the method may take a predetermined period of time to perform, and in between these steps there may be incubation and/or waiting steps, which are not shown for the sake of simplicity.

**[0301]** In a sample transferring step 1002, a sample, such as a chemical sample specimen 970 is transferred from outside apparatus 900 via receiving element 918 into sample composition chamber 904. According to some embodiments, the volume of the specimen or sample is less than 200  $\mu\text{L}$ , less than 100  $\mu\text{L}$ , less than 50  $\mu\text{L}$ , less than 25  $\mu\text{L}$  or less than 11  $\mu\text{L}$ .

**[0302]** In a pump activating step, pump 940 is activated for a period of time.

**[0303]** In a sample introduction step 906, a first small volume of sample 966 is introduced to the treatment chamber. The volume of the sample 966 may be, for example, less than in the range of 50-100  $\mu\text{L}$ , 25-50  $\mu\text{L}$ , 10-25  $\mu\text{L}$ , or 0-10  $\mu\text{L}$ .

**[0304]** Apparatus may comprise hardware and software elements (not shown), which enable the pre-programming of pump 940, as is known in the art. For example, the pump may be switched on and off at regular predetermined time

intervals such that only a small volume of sample 970 can be introduced at any time into the treatment chamber, such as small volume 960. The pump may be further actuated to introduce air 380 into the chamber in small volume samples 950 to clean and separate between different small volumes of samples 960, 962, 964 and 966.

5 [0305] In an air introduction step 1008, a small volume of air 950 is transferred from container 901 via an air line 903 into the treatment chamber. The volume of the small volume of air sample 950 may be, for example, less than in the range of 50-100  $\mu\text{L}$ , 25-50  $\mu\text{L}$ , 10-25  $\mu\text{L}$ , or 0-10  $\mu\text{L}$ . The air separates the treated aliquots and cleans the channel to prevent carryover as is known in the art, Skeggs, 1964, 1966.

[0306] Steps 1006, 1008 may be repeated a number of times. There may be a decision step 1010 to decide on whether to repeat these steps.

10 [0307] In a treatment composition transfer step 1012, one or more treatment compositions is transferred to a specific region of the treatment chamber via transfer elements/lines 907, 909, 910. The number of treatment compositions introduced into each small volume of sample depends on the nature of the assay/test being performed. As was mentioned hereinabove, each small volume of sample may be treated with one specific composition or a combination of compositions in sequence. Moreover, each treatment composition 920, 922, 924 may each comprises a number of different reagents, markers, cofactors, catalysts, enzymes and combinations thereof.

15 [0308] In some cases, there may be at least one other treatment composition or liquid (not shown) disposed in the treatment chamber.

[0309] Depending on the nature of the treatment composition and sample/specimen type, there may be a requirement to mix or agitate the treatment chamber contents in an optional mixing step 413 (not shown).

20 [0310] In some cases, some of these steps 1006, 1008, 1010, 1012 may be performed concurrently.

[0311] In a first transferring step 1014, the first small sample 966 after treatment with composition 924 is transferred to the evaluation chamber.

[0312] The evaluation chamber 914 is configured and constructed for one or more evaluation steps 1016. These may include any combination or permutation of the following:

- 25
- transfer of radiation there-through,
  - impinging radiation thereupon;
  - detecting reflected and/or refracted radiation,
  - detecting emitted radiation;

30

  - capturing one or more images thereof;
  - performing image analysis on the captured images;
  - measuring electrical characteristics of the treated specimen;
  - impinging sonic energy thereon;
  - detecting sonic energy therefrom; and

35

  - analyzing the outputs of any one or more of the above steps.

[0313] According to some embodiments, the cartridge is introduced into a system as described in International patent application publication no. WO2011/128893 to Kasdan et al., incorporated herein by reference.

40 [0314] Steps 1014, 1016 may be repeated a number of times. There may be a decision step 1018 to decide on whether to repeat these steps. For example, the evaluation step 1016 may be performed on each small volume of sample 966, 964, 962 and 960 sequentially. Additionally or alternatively, evaluation step may be performed a number of times of the same sample, so as to determine kinetic data and the like.

[0315] Additionally or alternatively, the evaluation step may be performed at one location in the reading zone or may be performed at a number of sequential locations in the reading zone.

45 [0316] The results of the evaluation step are then outputted in a results outputting step 1020.

[0317] According to some embodiments; the apparatus may have on-board means for showing a result, such as a colorimetric strip (not shown). Additionally or alternatively, the results are displayed in a display unit, separate and remote from apparatus 900.

50 [0318] The time required to complete an assay using apparatus 100 or apparatus 900 varies depending on a number of factors, with non-limiting examples that include described herein. In some embodiments, the time required to complete an assay is from about 0.5 to 100 minutes. In other embodiments, the time required to complete an assay is from about 1 to 20 minutes. In still other embodiments, the time required to complete an assay is from about 1 to 10 minutes. In some examples, the time required to complete an assay is from about 1, 2, 3, 4, 5, 6, 7, 8, 9, 10, 15, 20, 25, 30, 35, 40, 50, 60, 80, or 100 minutes.

55 [0319] Reference is now made to Fig. 11, which is a simplified schematic illustration showing a methodology 1100 for detecting and quantifying glucose, protein and albumin in a serum sample, in accordance with an embodiment of the present invention. These tests are for exemplification and should not be deemed as limiting. Details of these tests are found in Schwartz et al., 1974.

[0320] According to some embodiments, the method is carried out in the apparatus 900 shown in Fig. 9 and as described herein. A specimen, such as a serum sample, is aspirated via specimen receiving element 918 to sample composition chamber 904, and then to treatment chamber 912. The sample is typically of a volume in the range of 10-200  $\mu$ L.

[0321] The serum sample is typically prepared from a whole blood sample, recently removed from a patient. Air 901 is also introduced into the treatment chamber.

[0322] As is seen in Fig. 9, a first small volume of sample (serum 966) appears near to a second end 917 of the treatment chamber. At time zero ( $T_0$ ), no treatment compositions have been mixed with sample 966.

[0323] At time  $T_1$  after time zero ( $T_0$ ), a first composition (glucose color producing reagent GCPR 1124) is reacted in the sample 1166, (possibly) with glucose therein to form glucose reacted with the GCPR 1166. Any protein 1164, albumin 1162 and other analytes 1160 remain untreated and hence unaffected.

[0324] At a time later than  $T_1$ , such as  $T_2$ , a protein color producing reagent PCPR 1122) is reacted with another sample 1164, (possibly) with protein therein to form protein reacted with the PCPR 1104. Any glucose 1102, albumin 1106 and other analytes 1108 remain untreated and hence unaffected.

[0325] At a time later than  $T_2$ , such as  $T_3$ , an albumin color producing reagent ACPR 1120) is reacted with another sample 1162, (possibly) with albumin therein, to form albumin reacted with the ACPR 1116. Any glucose 1112, protein 1114 and other analytes 1118 remain untreated and hence unaffected.

[0326] Detection of glucose reacted with the GCPR 1166 in sample 1166, protein reacted with the PCPR 1104 in sample 1164 and albumin reacted with the ACPR 1116 in sample 1162 are then detected using the colorimetric methods described in Schwartz, et al., 1974, for example, in the detection zone 930 of the evaluation chamber 914. The detection may be performed using the systems described in International patent application publication no. WO2011/128893 to Kasdan et al.

[0327] Table 3 shows some representative chemical applications of apparatus 100 and methods of the present invention.

Table 3. Chemical Applications of the apparatus and methods of this invention.

Application	Type of Test	Relevant Figs.	Literature References
Blood chemistry parameters, such as albumin, total protein, chloride, carbon dioxide, sodium, potassium, glucose, and urea and nitrogen	Blood chemistry	1-5	Skegg et al. 1964
Blood chemistry parameters such as glucose, urea nitrogen, creatinine, carbon dioxide content, total bilirubin, calcium, phosphorus, cholesterol, iron, uric acid, chloride, sodium, potassium, total protein, albumin, creatine kinase, alkaline phosphatase, lactate dehydrogenase, and aspartate and alanine aminotransferases)	Blood chemistry	1-5	Schwartz et al. (1974)
Blood chemistry parameters such as glucose, urea nitrogen, creatinine, carbon dioxide content, total bilirubin, calcium, phosphorus, cholesterol, iron, uric acid, chloride, sodium, potassium, total protein, albumin, creatine kinase, alkaline phosphatase, lactate dehydrogenase, and aspartate and alanine aminotransferases)	Blood chemistry	1-5	Westgard et al. (1976)
pH, protein, glucose, ketone, bilirubin, blood, Urobilinogen, nitrite, leukocytes, specific gravity	Urinalysis	1-5	Free et al., (1972)

[0328] Reference is now made to Fig. 12A, which is a simplified three dimensional front view 1201 of a reader assembly 1200 and cartridge 1210 for detecting a biological condition, in accordance with an embodiment of the present invention.;

[0329] Shown in Fig. 12A are the reader assembly 1200 and the cartridge 1210. The cartridge is inserted in the reader assembly as shown. Once the cartridge is inserted in the reader assembly all assay pre-analytical processing and analysis are performed automatically. Results of the analysis are displayed on a user interface touchscreen 1215, which is also used to control operation of the reader.

[0330] Fig. 12B shows a simplified three dimensional inner front view 1203 of reader assembly 1200 for detecting a biological condition, in accordance with an embodiment of the present invention.

[0331] The internal components of the reader assembly are shown in Fig. 12B. There is seen left side view 1220, showing an ITX computer, 1222, a Galil motor controller, 1224, an electronics power supply 1226, cartridge, 110, inserted into a cartridge handling unit (CHU) 128 and a forward scatter detector 1230. Also seen is a right side view 1240 showing reader optics 1242, a data acquisition board 1244 and a general electronics printed circuit board 1246.

**[0332]** Fig. 13A is an outer side view of a cartridge assembly 1300, in accordance with an embodiment of the present invention and Fig. 13B shows an inner side view 1350 of a cartridge assembly 1300, in accordance with an embodiment of the present invention.

**[0333]** Figs. 14A-14O show a sequence of process events in a cartridge assembly 1400, of the operation of an apparatus 100 (Fig. 1), for detecting a biological condition, in accordance with an embodiment of the present invention.

**[0334]** In Fig. 14A, a blood sample 1401 enters a specimen receiving element 1418 and fills a chamber 1404.

**[0335]** In Fig. 14B, a blister 1420 comprising a treatment composition 120 (Fig. 1) is pressed an antibody cocktail is mixed with 10 micro-liters ( $\mu\text{L}$ ) of the blood sample.

**[0336]** In Fig. 14C, a mixing bellows 1415 is pressed and this effects mixing of the antibody cocktail and the 10 microliters of the blood sample in a first mixing chamber 1412 to form a first mixture 1403.

**[0337]** In Fig. 14D, the bellows is released and mixture 1403 is siphoned along a tortuous channel 1413 and into a second mixing chamber 1411. Upon release of the bellows, the first mixture returns from the second mixing chamber, back along the tortuous channel to the first mixing chamber. Every time the bellows is pressed the mixture moves towards the second chamber and every time it is released, it returns, wholly or in part to the first chamber. This mixing may be performed multiple times.

**[0338]** In Figs. 14E-14G, a second composition blister 1422 is pressed, releasing a second composition 122 (Fig. 1), such as a lysis composition thereby forming a second mixture 1405. The second mixture is mixed by pressing of bellows 1415, the second mixture returns from the second mixing chamber, back along tortuous channel 1413 to the first mixing chamber. Every time the bellows is pressed the mixture moves towards the second chamber 1411 and every time it is released, it returns, wholly or in part to the first chamber 1412. This mixing may be performed multiple times.

**[0339]** In Figs. 14H-14J, a third blister 1424 is released comprising a third composition 124 (Fig. 1), such as a control reference, into the second mixing chamber, thereby forming a third composition 1407. The third mixture is mixed by pressing of bellows 1415, the third mixture returns from the second mixing chamber, back along a tortuous channel 1413 to the first mixing chamber. Every time the bellows is pressed the mixture moves towards the second chamber 1411 and every time it is released, it returns, wholly or in part to the first chamber 1412. This mixing may be performed multiple times.

**[0340]** In Figs. 14J-14M, a reading bellows 1417 is pressed, which forces some of the third composition towards a reading cuvette 1430.

**[0341]** In Figs. 14N-14O, particles 1460 from the third composition flow from the cuvette 1430 along a channel 1452 to a reading region 1450. The cells pass through the reading region and are excited by one or more lasers 1462, 1463. At least one excitation laser beam 1464 impinges on cell 1460 and an emission beam 1466 is detected by a detector 1470. In one example, this is cell emission fluorescence and detector 1470 is a spectrometer.

**[0342]** Fig. 15 is a schematic illustration of a micro flow spectrometer reading, in accordance with an embodiment of the present invention;

**[0343]** An individual cell 1505 flows through a detection region 1510 in a microfluidic channel. Additionally, tagged cells 1520 labeled with antibodies conjugated with multiple wavelength fluorescent tags flow through the detection region. A diode laser 1530 impinges a ray/beam 1510 onto the cells and tagged cells. The cells and tagged cells emit different emission spectra (not shown). An optical grating 1540 disperses emission spectra via a grating 1540 into its constituent wavelengths 1550.

**[0344]** A photomultiplier tube (PMT) array 1560 or avalanche diode array detects fluorescence at 8 different spatial locations corresponding to 8 spectral regions.

**[0345]** Fig. 16 shows the main modular components of the reader optics assembly. A complete side view 1620 of the optical assembly is seen, in addition to a top view 1622. A laser unit 1603 includes a laser and beam expander in its heatsink assembly. An excitation and emission collection optics 1604. A photomultiplier (PMT) assembly 1602.....

**[0346]** Fig. 17 shows details of the photomultiplier (PMT) assembly. A side view and an end view of the PMT assembly are shown as side view 1770 and end view 1772 respectively. The major elements of the PMT assembly include a PMT box 1751, a PMT grating assembly 1752, a PMT bridge assembly 1755, a PMT cover 1758, a PMT unit 1759, a PMT lens assembly 1760, a PMT pinhole nut 1761, a pinhole 1762, a pinhole hood 1763 and an adjustment bar 1765.

**[0347]** Fig. 18A shows a reader optics assembly 1810, a cartridge handling unit 1812 and a forward scatter detection unit 1814, in accordance with an embodiment of the present invention.

**[0348]** Fig. 18B shows a right side view of a complete reader optics assembly 1842, in accordance with an embodiment of the present invention.

**[0349]** Fig. 18C shows a left side view of the reader optics assembly, in accordance with an embodiment of the present invention.

**[0350]** Fig. 18D is a forward scatter detection assembly 1830, in accordance with an embodiment of the present invention. This assembly contains LEDs, 1852, to illuminate a reading channel (reading zone 130, Fig. 1) during an autofocus process, a stop 1858, to block low angle scatter and a lens 1856 to collect the desired forward scatter for the detection photodiode (such as (PMT) array 1560, Fig. 15).

**[0351]** Fig. 18E is a side view of forward scatter detection assembly 1830, in accordance with an embodiment of the present invention. Shown in this view are an illumination lens 1850, an collection lenses 1856, 1857, and 1858, as well as a detection photodiode 1860.

**[0352]** Fig. 19A shows a cutaway view of reader assembly 1930, in accordance with an embodiment of the present invention. This cutaway view of the reader assembly showing its components in its front and on a left side. These components include an ITX board 1922, a cartridge handling unit 1928, and the forward scatter detection assembly, 1930.

**[0353]** Fig. 19B shows an exploded right side view of a reader assembly 1905, in accordance with an embodiment of the present invention. The three major components in this view are a reader optics assembly 1942, a cartridge handling unit 1928, and a forward scatter detection module 1930.

**[0354]** Fig 19C shows a left side blown up view of the reader assembly, in accordance with an embodiment of the present invention. Shown in this view are ITX computer board 1922, cartridge handling unit 1928, forward scatter detection assembly 1930, and the other side of the reader optics assembly 1942.

**[0355]** Fig 19D shows a rear view of cartridge handling unit (CHU) 1928, in accordance with an embodiment of the present invention. In this view, a handle 1901 of the inserted cartridge, 1910, can be seen. Sensors 1912 are configured therein to detect the position of motors 1910, and actuators 1914, which are adapted to crush the blisters, 106, 108, 110 (Fig. 1) or 1420, 1422, 1424 (Figs. 14A-14L) as well as an actuator 1916 to operate the bellows (940, Fig. 9, 1415, 1417 Figs. 14A-L), can be seen on the shafts of the motor. An opening 1918 is provided for the microscope objective 2138 (Fig. 21A) to view the reading channel on the cartridge.

**[0356]** Fig. 19E shows a front view of a cartridge handling unit (CHU), in accordance with an embodiment of the present invention. This figure shows the front view of the cartridge handling unit (CHU) 1928. In this view, the handle in the upper portion of cartridge 1910 can be seen. A port 1920 to view the microfluidic path is provided. This port is viewed by a camera 1930, in order to ensure that the correct operation occurs within the cartridge. Another opening 1940 is provided for the forward scatter to exit the cartridge handling unit and be observed by the forward scatter detection assembly 1930.

**[0357]** Fig. 19F shows an exploded view of a reader optics assembly 1999, in accordance with an embodiment of the present invention.

**[0358]** Fig. 20 is a simplified illustration of a disposable cartridge 2050 for rapid determination of a medical condition, in accordance with an embodiment of the present invention;

Disposable cartridge 2050 is adapted to receive a bodily fluid, such as, but not limited to, blood, urine, serum or plasma. The disposable cartridge is constructed and configured to have several different sections 2052, 2054, 2056 and 2058. Section 2052 is a body fluid aspiration section, which is adapted to receive the body fluid directly or indirectly from the patient (or animal) and this section acts as a reservoir of the body fluid.

**[0359]** Disposable cartridge 2050 comprises fluid conveying means between the sections, such as, but not limited to, air pressure, liquid pressure, mechanical means and combinations thereof. Body fluid aspiration section 2052 is adapted to convey a predetermined quantity of the body fluid (a body fluid sample 2051) to a pre-analytical sample processing section 2054.

**[0360]** In pre-analytical sample processing section 2054, at least one preparatory step is performed on the body fluid such as, but not limited to:

- a) incubation with at least one antibody;
- b) incubation with at least one antigen;
- c) staining of at least one cell type in the body fluid;
- d) enzymatic lysing of at least one cell type of the body fluid;
- e) osmotic lysing of at least one cell type of the body fluid;
- f) heat or cool at least part of the bodily fluid;
- g) addition of reference material to the bodily fluid; and
- h) chemical reaction with at least one element of the body fluid.

**[0361]** The pre-treated sample of bodily fluid is then conveyed from pre-analytical sample processing section 2054 to a sample excitation/interaction zone or section 2056. This pre-treated sample may be conveyed continuously or in a batch mode to sample excitation/interaction section 2056.

**[0362]** Fig. 21A is a simplified schematic illustration of an optical arrangement of a reader optics assembly 2100, in accordance with an embodiment of the present invention;

**[0363]** A laser 2140 or other appropriate light source provides a light beam 2142, which may be directed towards a plurality of optical elements, including a dichroic filter 2143, a beam splitter 2144, a focusing lens 2145, a pinhole 2146 and a silicon reader unit 2147, for recording a signal from a beam 2142 directed through the objective 2138 towards a sample 2150 and returned to the optical unit. Additional optical elements may include an optional attenuator 2148, a high-pass filter 2149, a focusing lens 2151, a slit 2152, a concave grating 2153, and a PMT array 2154.

**[0364]** This arrangement of elements, representing an embodiment of the present invention, allows for generation of

excitation light, focusing it on a sample, collecting reflected and emitted light signal resulting from the interaction of the excitation light and fluorophores in the sample and recording said returned light so as to determine fluorescence of sample in response to light illumination from laser 2140.

[0365] With respect to Fig. 21A, the laser illumination 2142 is reflected by the dichroic filter 2143 through the objective 2138 and focused on the channel containing the flowing particles 2158. This illumination excites the fluorophores attached to the protein markers that are bound to the cells. The resulting fluorescent illumination is collected by the objective 2138 and because of the longer wavelength of this emission passes through the dichroic filter 2143 and is reflected by the beam splitter 2144 through the high pass filter 2149. The high pass filter blocks any reflected laser illumination. The focusing lens 2151 focuses the multi-wavelength emission illumination on the slit 2152. The concave grating 2153 images the slit at multiple wavelengths on the elements of the PMT array 2154. This completes the process of creating a multispectral detection of the fluorescent emission. While most of the illumination collected by the objective is reflected by the beam splitter 2144 a small fraction is allowed to pass through and is focused by focusing lens 2145 through a pinhole 2146 on the silicon reader unit 2147, which may be a single photodiode or a focal plane array such as CCD sensor.

[0366] During the focusing operation, best focus is achieved when the signal on this reader unit 2147 is maximized. When this signal is maximized, the intensity of the signal on the PMT array 2154 is also maximized.

[0367] Reference is now made to Fig. 22A, which is a schematic representation 2200 of one example of multi-wavelength excitation in the optical unit of Fig. 21A or 21B, in accordance with an embodiment of the present invention. Figs. 22A-22C show an extension of the optical configuration in Figs. 21A and 21B, to allow multiple excitation wavelengths.

[0368] Fig. 22A shows the configuration for combining multiple lasers of different wavelengths to yield a single coaxial beam 2214 (see fig) containing all of the wavelengths. Two different wavelengths, such as green 2202 and red 2206, may be combined using a dichroic mirror 2204. One of the beams, red 2206 is reflected by the dichroic mirror, while the second beam, green 2202 passes through the dichroic mirror to yield a single beam 2208, yellow, containing both wavelengths. This combined wavelength beam is now used as one of the inputs to a second dichroic mirror 2210 with the third wavelength 2212 being reflected by the second dichroic mirror to yield a single coaxial beam 2216 containing all three wavelengths.

[0369] Reference is now made to Fig. 22B, which shows a graphical output 2220 of transmission as a function of wavelength for a dichroic filter 2200 of Fig. 7B, employing the multi-wavelength excitation of Fig. 22A, in accordance with an embodiment of the present invention. A multiband dichroic mirror (not shown) similar, or identical to, mirror 2252 of Fig. 22C is used to illuminate the sample through an objective 2254 (Fig. 8C), while allowing the resulting emission to pass through dichroic mirror 2252 at all wavelengths, except those of multibeam excitation 2214 (Fig. 8A). In this way the same epi-configuration used with a single wavelength can, in fact, be used with appropriate changes to dichroic mirror 2252 and the addition of multiple lasers 2202, 2206, 2212 to provide multi-wavelength excitation, while maintaining virtually all of the detection wavelengths of a single excitation system.

[0370] Turning to Fig. 22C, a schematic representation of part 2250 of the optical unit is seen, employing multi-wavelength excitation of Fig. 22A and the dichroic filter of Fig. 22B, in accordance with an embodiment of the present invention. Part 2250 may, in some cases, replace subsystem 2175 (Fig. 21B).

Table 4. Representative values for representative components for use in the present invention.

Laser Wavelength	405nm	488nm
Laser Power	50mW	20mW
Sensing Spectral Range	200nm	200nm
Spectral Resolution	25nm	25nm
Number of Detectors	8	8
Collecting Optics	Microscope Objective N.A.>0.4, W.D. ≈ 6mm	Microscope Objective N.A.>0.4, W.D. ≈ 6mm
Detector Type	S.S. PMT 8 ch	S.S. PMT 8 ch

[0371] While much of the previous discussion has focused on the optical elements of some embodiments of the present invention, one of the key components of the diagnostic system herewith presented is a disposable sample cartridge.

[0372] Reference is now made to Fig. 23A, which is a schematic view of a sampling cartridge 110 of Fig. 19A, or 102 (Fig. 1) in accordance with an embodiment of the present invention. The cartridge 2350 includes a pre-analytical component 2352 into which a sample (not shown) may be introduced.

[0373] The sample will generally be blood, either whole or a component (serum, etc.) thereof. Other liquid samples may additionally or alternatively be employed. In the pre-analytical component 2352, the sample is allowed to interact

with chemicals prepackaged into component 2352. The interaction may be either passive or include active mixing.

**[0374]** The chemicals included in the analytical component 2352 may be either wet or dry, and generally include antibodies associated with fluorescent probes. Antibodies are pre-selected for their ability to bind with predetermined biological markers or the like. In a typical experiment, a predetermined volume (generally less than 50 microliters) of blood is introduced into the pre-analytical component 2352 of a disposable cartridge 2350.

**[0375]** The sample is actively mixed with chemical reagents present in the pre-analytical component 2352 for a predetermined period of time, generally less than ten minutes. The sample is then moved through a capillary region 2353 by means to be discussed, where it is exposed to a light beam 2342 delivered from an objective 2338. Direction of sample flow is as shown by the arrow in the capillary region 2353.

**[0376]** The capillary region 2353 is designed to allow flow of particles in a single-file past the light beam 2342. Such an arrangement allows both for counting the number of particles as well as individual interrogation of particles to determine the presence of biological markers (via their associated fluorescent tags) on each particle. Such a physical arrangement allows for detection of one or more biological markers (independent of particle-specific properties such as size, shape, and number) on each particle.

**[0377]** Finally, there is a collection component 2354 which receives sample after exposure to light beam 2342. This is a waste region and allows for a completely self-contained disposable for sample preparation, analysis and waste collection. It is noted that the disposable cartridge may be of any relevant shape and is shown as it is in Fig. 20 for ease of understanding of its components and functionality.

**[0378]** As mentioned above, the sample, after pre-analytical treatment to allow for binding of fluorescent tag to cells/particles, must flow under a light beam 2342, produced by an optical unit (not shown). The flow is generally "single file" so as to allow for accurate determination of cell-specific markers on each analyzed cell. Methods to induce flow include but are not limited to electrical stimulation, chemical induction, and vacuum pull. In an electrical stimulation system, charge is applied across the capillary region 2353 so as to induce charged particles to move from the pre-analytical component 2352 towards the collection component 2354. The charge could be supplied by the cytometer in which the disposable cartridge 2350 is placed or from an external source.

**[0379]** Alternatively, the capillary region may include chemical features (hydrophilic/hydrophobic; positive/negative charge) to encourage sample to move from left to right as shown in Fig. 23A. Alternatively, a vacuum from the collection component 2354 could be applied to pull sample from the pre-analytical component 2352 through the capillary region 2353. Other methods may be employed to get liquid sample to move underneath the light beam 2342 for analysis.

**[0380]** As described herein, the optics and sample handling have been handled separately. Such an arrangement is not mandatory, as some of the optical features needed for proper sample analysis may be included in a disposable cartridge.

**[0381]** Reference is now made to Fig. 23B, which shows a schematic view of disposable cartridge 2300 in flow-cytometer device, such as system 100 in accordance with an embodiment of the present invention. Attention is currently turned to Fig. 23B which shows an expanded view of a capillary region 2353. In the capillary region 2353, particles 2390 flow in the direction as suggested by the arrow 2380.

**[0382]** Particles 2390 flow past an objective 2338 that shines light 2342 through the capillary 2353. Flow restriction elements 2394 may be present in the capillary region 2353 so as to encourage particles 2390 to move past the light 2342 in a nearly single-file manner. Passage of multiple particles together may be resolved through processing software.

**[0383]** A molecular marker 2395 on a particle 2390 may be illuminated by light 2342 and its fluorescence will be captured by a proximate photomultiplier tube 2399. The photomultiplier tube 2399 may distinguish the wavelength of the fluorescence and thus which biological marker 2395 is present on particle 2390. Thus, the systems of the present invention may determine which biological markers are present on particles 2390, which are detected in the systems of the present invention. A photomultiplier tube 2399 may have a plurality of tubes or an array of elements for fine wavelength discrimination and alternatively may be replaced with film, CCD or other appropriate light-receiving reader unit. It should be understood that Fig. 23B shows one embodiment of the configuration of system 1200 (Fig. 12) in a transmissive configuration, wherein detector (photomultiplier tube 2399) is disposed on an opposing side of the cartridge 2300 to objective 2338.

**[0384]** The systems of the present invention comprise controller software which are adapted to run a diagnostic process. It is understood that the controller software may be an integral part of the flow-cytometer or alternatively be installed on an associated computing device (see Figs 1 & 12A), which may include, but not be limited to, a laptop computer, iPod, iPad, cell phone or mainframe computer.

**[0385]** Reference is now made to Fig. 24, which is a simplified flowchart 2400 of a method for rapid determination of a medical condition, in accordance with an embodiment of the present invention. It is to be understood that the method described herein depicts one non-limiting embodiment of the present invention for determining the health state of a patient. Further embodiments are also construed to be part of the present invention.

**[0386]** In a body fluid provision step 2402, a body fluid, such as blood, urine, serum or plasma is provided from a human or animal patient. Typically, the sample is fresh, but may also be a stored, refrigerated or frozen-thawed sample.

The fluid is typically liquid and at a temperature of 4-37 °C.

**[0387]** In a body fluid introduction step 2404, part or all of the body fluid sample 2051 (Fig. 20) is introduced into disposable cartridge (102, Fig. 1).

**[0388]** In a reacting step 2406, the fluid sample is reacted with at least one reactant in the cartridge forming a treated sample. According to some embodiments, this step is performed in pre-analytical sample processing section 2054 (Fig. 20) as described in detail hereinabove.

**[0389]** In an impinging step 2408, radiation is impinged on the treated sample, such as, but not limited to, in sample excitation/interaction section 2056, thereby generating a plurality of spectrally distinct signals in the direction of optics unit 1242 (Fig. 12C, see description hereinabove).

**[0390]** In a spectral emissions detection step 2410, a plurality of spectrally distinct signals is detected by multiple emission detector 2154 (Fig. 21A). The detector outputs data.

**[0391]** Thereafter, in a data processing step 2412, the outputted data is processed by signal processor 2036 (Fig. 20) and/or by computer 1222 (Fig. 12C) to provide an output indicative of a medical condition.

**[0392]** Fig. 25 is a three-dimensional graph showing the optical output over time of reference beads (RM) relative to a sample from a human patient (PMN), in accordance with an embodiment of the present invention.

**[0393]** Fig. 25 shows a three-dimensional graph showing the optical output over time of reference beads (RM) relative to a sample from a human patient (PMN), in accordance with an embodiment of the present invention. The emission amplitude in the six bands, 500-525 nm, 525-550 nm, 550-575 nm, 575-600 nm, 600-625 nm and 625 to 650 nm is displayed in the graph for each sample time. Different fluorophores have different emission spectra. It can be appreciated that both spectral content or shape and amplitude at individual wavelengths are significantly different for neutrophils stained with Acridine Orange (AO) and reference beads (RM) containing a bright broad spectrum fluorophore. The peak of the AO emission is in the 525-550 nm band, while that of RM is in the 500-525 nm band and is of a significantly greater amplitude than AO in any band.

**[0394]** Figs. 26A-26C show graphs of optical outputs over time of the reference beads and the sample from a human patient, in accordance with an embodiment of the present invention.

**[0395]** Turning to Figs. 26A-26C, there can be seen graphs of optical outputs over time of the reference beads and the sample from a human patient, in accordance with an embodiment of the present invention. In these two-dimensional figures, the traces from each of the bands are overlaid on the same graph. Fig. 26A shows the boxed pulses from neutrophils in Fig. 26B.

**[0396]** It is seen from these graphs that the amplitude in the 525-550 nm channel exceeds the amplitude in the 500-525 nm channel, which is the characteristic of AO.

**[0397]** Fig. 26C shows a comparison of the AO stained neutrophil emission spectrum to that of the RM emission spectrum. The relative amplitude of the spectrum in the 500-525 nm band to that of the amplitude in the 525-550 nm band clearly distinguishes the two fluorophores. In addition, the maximum amplitude of the RM emission is significantly greater than that of AO.

**[0398]** The systems of the present invention, as described and shown herein provide uses, such as, but not limited to, at least one of the four following scenarios:

- a) When multiple pieces of information, such as biological markers and white cell state are required in order to make an accurate diagnostic determination;
- b) When multiple sequential measurements must be made in order to determine the position of a patient on an illness curve;
- c) When white cell and similar data are needed quickly and in a POC environment; and
- d) When fluorescent signals overlap in wavelength and there is need to determine relative contribution of each signal for a given wavelength range.

**[0399]** The systems, kits, methods, apparatus and cartridges of the present invention and priority documents provides a very useful platform for many laboratory applications. The following listing hereinbelow is meant to be exemplary and not to be deemed limiting.

**[0400]** The systems, kits, methods, apparatus and cartridges of the present invention can be applied to cell Surface Markers, such as a CD64 Assay (see US 8,116,984 and Davis, Bruce H., et al. "Neutrophil CD64 is an improved indicator of infection or sepsis in emergency department patients." Archives of pathology & laboratory medicine 130.5 (2006): 654-661.;Hoffmann, Johannes JML. "Neutrophil CD64 as a sepsis biomarker."Biochemia Medica 21.3 (2011): 282-290.

**[0401]** The systems, kits, methods, apparatus and cartridges of the present invention can be applied to cell Surface Markers, such as a CD64 Assay cell Surface Markers, such as a CD4/CD8 Assay (see Crowe, Suzanne, et al. "Monitoring of human immunodeficiency virus infection in resource-constrained countries." Clinical infectious diseases 37.Supplement 1 (2003): S25-S35.).

**[0402]** The systems, kits, methods, apparatus and cartridges of the present invention can be applied to stem cell

identification (see Nielsen, Julie S., and Kelly M. McNagny. "Novel functions of the CD34 family." *Journal of Cell Science* 121.22 (2008): 3683-3692.).

**[0403]** The systems, kits, methods, apparatus and cartridges of the present invention can be applied to Minimal Residual Disease Assays (see Rawstron, A. C., et al. "International standardized approach for flow cytometric residual disease monitoring in chronic lymphocytic leukaemia." *Leukemia* 21.5 (2007): 956-964; Rawstron, Andy C., et al. "Report of the European Myeloma Network on multiparametric flow cytometry in multiple myeloma and related disorders." *haematologica* 93.3 (2008): 431-438.; Brüggemann, M., et al. "Standardized MRD quantification in European ALL trials: proceedings of the Second International Symposium on MRD assessment in Kiel, Germany, 18-20 September 2008." *Leukemia* 24.3 (2009): 521-535.; Rawstron, A. C., et al. "Improving efficiency and sensitivity: European Research Initiative in CLL (ERIC) update on the international harmonised approach for flow cytometric residual disease monitoring in CLL." *Leukemia* 27.1 (2012): 142-149.; Böttcher, Sebastian, Matthias Ritgen, and Michael Kneba. "Flow cytometric MRD detection in selected mature B-cell malignancies." *Lymphoma*. Humana Press, 2013. 149-174.; Stehlíková, O., et al. "Detecting minimal residual disease in patients with chronic lymphocytic leukemia using 8-color flow cytometry protocol in routine hematological practice." *International journal of laboratory hematology* (2013).; Mullier, François, and Bernard Chatelain. "Immunophenotyping by flow cytometry." *Belgian Haematological Society: Postgraduate seminar of the on Laboratory Techniques*. 2013.; Wiestner, Adrian, et al. "ZAP-70 expression identifies a chronic lymphocytic leukemia subtype with unmutated immunoglobulin genes, inferior clinical outcome, and distinct gene expression profile." *Blood* 101.12 (2003): 4944-4951.

**[0404]** The systems, kits, methods, apparatus and cartridges of the present invention can be applied to lymphocyte subtyping (see Blue, MARIE-LUISE, et al. "Coexpression of T4 and T8 on peripheral blood T cells demonstrated by two-color fluorescence flow cytometry." *The Journal of immunology* 134.4 (1985): 2281-2286.; Lanier, Lewis L., and Michael R. Loken. "Human lymphocyte subpopulations identified by using three-color immunofluorescence and flow cytometry analysis: correlation of Leu-2, Leu-3, Leu-7, Leu-8, and Leu-11 cell surface antigen expression." *The Journal of Immunology* 132.1 (1984): 151-156.; Mercolino, Thomas J., et al. "Immunologic differentiation of absolute lymphocyte count with an integrated flow cytometric system: a new concept for absolute T cell subset determinations." *Cytometry* 22.1 (1995): 48-59.; Comans-Bitter, W. Marieke, et al. "Immunophenotyping of blood lymphocytes in childhood Reference values for lymphocyte subpopulations." *The Journal of pediatrics* 130.3 (1997): 388-393.; Inghirami, G., et al. "Flow cytometric and immunohistochemical characterization of the gamma/delta T-lymphocyte population in normal human lymphoid tissue and peripheral blood." *The American journal of pathology* 136.2 (1990): 357.).

**[0405]** The systems, kits, methods, apparatus and cartridges of the present invention can be applied to subtyping T subtypes and and natural killer (NK) subtypes.

**[0406]** The systems, kits, methods, apparatus and cartridges of the present invention can be applied to BO21 White Blood Cell Differential analysis (see Kass, Lawrence. "Metachromatic dye sorption and fluorescent light emissive means for differential determination of developmental stages of neutrophilic granulocytic cells and other leukocytes." U.S. Patent No. 4,500,509. 19 Feb. 1985.).

**[0407]** The systems, kits, methods, apparatus and cartridges of the present invention can be applied to cell cycle analysis, cell proliferation detection, cytokine detection and the like.

**[0408]** The systems, kits, methods, apparatus and cartridges of the present invention can be applied to detecting apoptosis using propidium iodide and/or other stains.

**[0409]** The systems, kits, methods, apparatus and cartridges of the present invention can be applied to plasma protein bead assays (see Cheng, Ann-Joy, et al. "Oral cancer plasma tumor marker identified with bead-based affinity-fractionated proteomic technology." *Clinical Chemistry* 51.12 (2005): 2236-2244.).

**[0410]** The systems, kits, methods, apparatus and cartridges of the present invention can be applied to solution changes (color, turbidity etc.- see Bonini, Pierangelo, et al. "Errors in laboratory medicine." *Clinical Chemistry* 48.5 (2002): 691-698.; Legrand, C., et al. "Lactate dehydrogenase (LDH) activity of the number of dead cells in the medium of cultured eukaryotic cells as marker." *Journal of biotechnology* 25.3 (1992): 231-243. LDH, LACTATE DEHYDROGENASE, and Green Top. "Lactate Dehydrogenase (LDH)." (1980).; Canning, D. M., and R. G. Huntsman. "An assessment of Sickledex as an alternative to the sickling test." *Journal of Clinical Pathology* 23.8 (1970): 736-737.

**[0411]** The systems, kits, methods, apparatus and cartridges of the present invention can be applied to combination analyses, such as, but not limited to:

1. Cell Surface Markers and Cell Element Staining

2. Apoptosis with Annexin (see Bossy-Wetzel, Ella, and Douglas R. Green. "Detection of apoptosis by annexin V labeling." *Methods in enzymology* 322 (2000): 15-18.).

3. Cell Surface Markers and Plasma Protein Bead Assays

4. Cell Element Staining and Plasma Protein Bead Assays

5. Cell Surface Markers and Solution Changes

5 6. 5. Cell Element Staining and Solution Changes

7. 2. Cell Cycle Analysis

10 **[0412]** The instant invention includes software and algorithms for proper data analysis and conversion of raw fluorescence data into actual concentrations of relative biological markers.

**[0413]** The references cited herein teach many principles that are applicable to the present invention. Therefore the full contents of these publications are incorporated by reference herein where appropriate for teachings of additional or alternative details, features and/or technical background.

15 **[0414]** It is to be understood that the invention is not limited in its application to the details set forth in the description contained herein or illustrated in the drawings. The invention is capable of other embodiments and of being practiced and carried out in various ways. Those skilled in the art will readily appreciate that various modifications and changes can be applied to the embodiments of the invention as hereinbefore described without departing from its scope, defined in and by the appended claims.

20 **REFERENCES**

**[0415]**

25 Assicot, Marcel, et al. "High serum procalcitonin concentrations in patients with sepsis and infection." *The Lancet* 341.8844 (1993): 515-518.

Aulesa, C., et al. "Validation of the Coulter LH 750 in a hospital reference laboratory." *Laboratory Hematology* 9.1 (2003): 15-28. Hawkins, Robert C. "Laboratory turnaround time." *The Clinical Biochemist Reviews* 28.4 (2007): 179.

30 Ault, Kenneth A. "Flow cytometric measurement of platelet function and reticulated platelets." *Annals of the New York Academy of Sciences* 677.1 (1993): 293-308.

35 Blajchman, Morris A., et al. "Bacterial detection of platelets: current problems and possible resolutions." *Transfusion medicine reviews* 19.4 (2005): 259-272.

Bodensteiner, David C. "A flow cytometric technique to accurately measure post-filtration white blood cell counts." *Transfusion* 29.7 (1989): 651-653.

40 Cheson, Bruce D., et al. "National Cancer Institute-sponsored Working Group guidelines for chronic lymphocytic leukemia: revised guidelines for diagnosis and treatment." *Blood* 87.12 (1996): 4990-4997.

Christ-Crain, Mirjam, et al. "Effect of procalcitonin-guided treatment on antibiotic use and outcome in lower respiratory tract infections: cluster-randomised, single-blinded intervention trial." *Lancet* 363.9409 (2004): 600-607.

45 Cristofanilli, Massimo, et al. "Circulating tumor cells, disease progression, and survival in metastatic breast cancer." *New England Journal of Medicine* 351.8 (2004): 781-791.

50 Davis, Bruce H., et al. "Neutrophil CD64 is an improved indicator of infection or sepsis in emergency department patients." *Archives of pathology & laboratory medicine* 130.5 (2006): 654-661.

Dieye, Tandakha Ndiaye, et al. "Absolute CD4 T-cell counting in resource-poor settings: direct volumetric measurements versus bead-based clinical flow cytometry instruments." *JAIDS Journal of Acquired Immune Deficiency Syndromes* 39.1 (2005): 32-37.

55 Divers, S. G., et al. "Quantitation of CD62, soluble CD62, and lysosome-associated membrane proteins 1 and 2 for evaluation of the quality of stored platelet concentrates." *Transfusion* 35.4 (2003): 292-297.

Drexler, Hans G., et al. "Diagnostic value of immunological leukemia phenotyping." *Acta haematologica* 76.1 (1986):

1-8.

Dziegiel, Morten Hanefeld, Leif Kofoed Nielsen, and Adela Berkowicz. "Detecting fetomaternal hemorrhage by flow cytometry." *Current opinion in hematology* 13.6 (2006): 490.

Fischer, Johannes C., et al. "Reducing costs in flow cytometric counting of residual white blood cells in blood products: utilization of a single platform bead free flow rate calibration method." *Transfusion* 51.7 (2011): 1431-1438.

Free, A. H., and H. M. Free. "Urinalysis, critical discipline of clinical science." *Critical Reviews in Clinical Laboratory Sciences* 3.4 (1972): 481-531.

Frengen, Jomar, et al. "Demonstration and minimization of serum interference in flow cytometric two-site immunoassays." *Clinical chemistry* 40.3 (1994): 420-425.

Frengen, J., et al. "Homogeneous immunofluorometric assays of alpha-fetoprotein with macroporous, monosized particles and flow cytometry." *Clinical chemistry* 39.10 (1993): 2174-2181.

Gosling, James P. "A decade of development in immunoassay methodology." *Clinical chemistry* 36.8 (1990): 1408-1427.

Graff, Jochen, et al. "Close relationship between the platelet activation marker CD62 and the granular release of platelet-derived growth factor." *Journal of Pharmacology and Experimental Therapeutics* 300.3 (2002): 952-957.

Guerti, K., et al. "Performance evaluation of the PENTRA 60C+ automated hematology analyzer and comparison with the ADVIA 2120." *International journal of laboratory hematology* 31.2 (2009): 132-141.

Hawkins, Robert C. "Laboratory turnaround time." *The Clinical Biochemist Reviews* 28.4 (2007): 179.

Hershman, M. J., et al. "Monocyte HLA-DR antigen expression characterizes clinical outcome in the trauma patient." *British Journal of Surgery* 77.2 (2005): 204-207.

Hilfrich, Ralf, and Jalil Hariri. "Prognostic relevance of human papillomavirus L1 capsid protein detection within mild and moderate dysplastic lesions of the cervix uteri in combination with p16 biomarker." *Analytical and Quantitative Cytology and Histology* 30.2 (2008): 78-82.

Hillier, Sharon L., et al. "A case-control study of chorioamnionic infection and histologic chorioamnionitis in prematurity." *New England Journal of Medicine* 319.15 (1988): 972-978.

Kibe, Savitri, Kate Adams, and Gavin Barlow. "Diagnostic and prognostic biomarkers of sepsis in critical care." *Journal of Antimicrobial Chemotherapy* 66.suppl 2 (2011): ii33-ii40.

LaRosa, Steven P., and Steven M. Opal. "Biomarkers: the future." *Critical care clinics* 27.2 (2011): 407.

Liu, N. I. N. G., A. H. Wu, and Shan S. Wong. "Improved quantitative Apt test for detecting fetal hemoglobin in bloody stools of newborns." *Clinical chemistry* 39.11 (1993): 2326-2329.

Lotan, Yair, et al. "Bladder cancer screening in a high risk asymptomatic population using a point of care urine based protein tumor marker." *The Journal of urology* 182.1 (2009): 52-58.

Masse, M., et al. "Validation of a simple method to count very low white cell concentrations in filtered red cells or platelets." *Transfusion* 32.6 (2003): 565-571.

Matic, Goran B., et al. "Whole blood analysis of reticulated platelets: improvements of detection and assay stability." *Cytometry* 34.5 (1998): 229-234.

McDonald, C. P., et al. "Use of a solid-phase fluorescent cytometric technique for the detection of bacteria in platelet concentrates." *Transfusion Medicine* 15.3 (2005): 175-183.

Michelson, Alan D. "Flow cytometry: a clinical test of platelet function." Open Access Articles (1996): 290.

Miller, E.M.; Freire, S.L.S.; Wheeler, A.R. "Proteomics in Microfluidic Devices" In Encyclopedia of Micro- and Nanofluidics; Li, D. Q., Ed.; Springer: Heidelberg, Germany, 2008; Vol. 3, pp 1749-1758..

5

Moro, Ricardo, et al. "A new broad-spectrum cancer marker." Vitro Diagnostic Technology (2005).

Ozanich Jr, Richard M., et al. "Rapid multiplexed flow cytometric assay for botulinum neurotoxin detection using an automated fluidic microbead-trapping flow cell for enhanced sensitivity." Analytical chemistry 81.14 (2009): 5783-5793.

10

Pál, József, et al. "Sandwich type ELISA and a fluorescent cytometric microbead assay for quantitative determination of hepatitis B virus X antigen level in human sera." Journal of immunological methods 306.1 (2005): 183-192.

15

Perry, Sara E., et al. "Is low monocyte HLA-DR expression helpful to predict outcome in severe sepsis?." Intensive care medicine 29.8 (2003): 1245-1252.

Ramakumar, Sanjay, et al. "Comparison of screening methods in the detection of bladder cancer." The Journal of urology 161.2 (1999): 388-394.

20

Rawstron, Andy C., et al. "Quantitation of minimal disease levels in chronic lymphocytic leukemia using a sensitive flow cytometric assay improves the prediction of outcome and can be used to optimize therapy." Blood 98.1 (2001): 29-35.

25

Rodriguez, William R., et al. "A microchip CD4 counting method for HIV monitoring in resource-poor settings." PLoS medicine 2.7 (2005): e182.

Rylatt, D. B., et al. "An immunoassay for human D dimer using monoclonal antibodies." Thrombosis research 31.6 (1983): 767-778.

30

Sacks, David B., et al. "Guidelines and recommendations for laboratory analysis in the diagnosis and management of diabetes mellitus." Clinical Chemistry 48.3 (2002): 436-472.

Schwartz, Morton K., et al. "Chemical and Clinical Evaluation of the Continuous-flow Analyzer" SMAC." Clinical Chemistry 20.8 (1974): 1062-1070.

35

Segal, H. C., et al. "Accuracy of platelet counting haematology analysers in severe thrombocytopenia and potential impact on platelet transfusion." British Journal of Haematology 128.4 (2005): 520-525.

Skeggs, Leonard T. "Method and apparatus for sequentially performing analyses on a plurality of fluid samples." U.S. Patent No. 3,241,432. 22 Mar. 1966.

40

Skeggs, Leonard T., and Harry Hochstrasser. "Multiple automatic sequential analysis." Clinical Chemistry 10.10 (1964): 918-936.

Stein, Paul D., et al. "D-dimer for the exclusion of acute venous thrombosis and pulmonary embolism: a systematic review." Annals of internal medicine 140.8 (2004): 589.

45

Sutherland, D. Robert, et al. "The ISHAGE guidelines for CD34+ cell determination by flow cytometry." Journal of hematotherapy 5.3 (1996): 213-226.

Wang, Chao, et al. "Reticulated platelets predict platelet count recovery following chemotherapy." Transfusion 42.3 (2002): 368-374.

50

Westgard, J. O., et al. "Performance studies on the Technicon" SMAC" analyzer: Precision and comparison of values with methods in routine laboratory service." Clinical chemistry 22.4 (1976): 489-496.

55

**[0416]** Embodiments of the invention, corresponding to the original claims of PCT/IL2013/000092 (WO 2014/097286), include the following:

## EP 3 508 848 A1

1. A self-contained system for performing an assay for determining a chemical state, the system comprising:
- a. a stationary cartridge for performing the assay therein;
  - b. at least one reagent adapted to react with a sample; and
  - c. at least one reporter functionality adapted to report a reaction of said at least one reagent with said sample to report a result of said assay;

wherein said at least one reagent, said sample and said at least one reporter functionality are contained within said cartridge.

2. A system according to embodiment 1, wherein said assay is a flow cytometric assay.
3. A system according to embodiment 1, wherein said chemical state is a biochemical state.
4. A system according to embodiment 3, wherein said biochemical state is indicative of a biological condition.
5. A system according to embodiment 1, wherein said sample is a biological sample.
6. A system according to embodiment 5, wherein said biological sample is a bodily sample.
7. A system according to embodiment 6, wherein said bodily sample is selected from the group consisting of blood, serum, plasma, urine, saliva, cerebrospinal fluid (CSF), serous fluid, peritoneal fluid and synovial fluid blood, urine, plasma, serum and saliva.
8. A system according to embodiment 1, wherein said cartridge is valveless.
9. A system according to embodiment 1, wherein said cartridge is a disposable microfluidics cartridge.
10. A system according to embodiment 1, wherein said at least one reagent comprises at least one of:
  - a. at least one target antibody;
  - b. at least one positive control identifying antibody; and
  - c. at least one negative control identifying detection moiety.

11. A system according to embodiment 1, wherein said at least one reagent comprises at least one reference composition comprising at least one of:

- a. a target signal reference composition; and
- b. a reference identifier composition.

12. A method for performing an assay for determining a chemical state in a self-contained stationary cartridge, the method comprising:

- a. introducing a sample into said cartridge;
- b. reacting at least one reagent with said sample; and
- c. detecting a signal associated with at least one reporter functionality, said at least one reporter functionality adapted to report a reaction of said at least one reagent with said sample, thereby determining said chemical state.

13. A method according to embodiment 12, further comprising forming at least one product and detecting a signal associated with said product.

14. A method according to embodiment 12, wherein said assay is a flow cytometric assay.
15. A method according to embodiment 12, wherein said chemical state is a biochemical state.
16. A method according to embodiment 12, wherein said biochemical state is indicative of a biological condition.
17. A method according to embodiment 12, wherein said sample is a biological sample.
18. A method according to embodiment 17, wherein said biological sample is a bodily sample.
19. A method according to embodiment 18, wherein said bodily sample is selected from the group consisting of blood, serum, plasma, urine, saliva, cerebrospinal fluid (CSF), serous fluid, peritoneal fluid and synovial fluid.
20. A method according to embodiment 12, wherein said at least one reagent comprises:

- a. a cell surface marker;
- b. a cell stain;
- c. a reagent bound to a solid support;
- d. a chemical indicator; and
- e. a biological cell indicator.

21. A method according to embodiment 20, wherein said cell surface marker is selected from the group consisting of CD64, CD4, CD8, a stem cell indicator, a Minimal Residual Disease indicator and a lymphocyte subtype indicator.

22. A method according to embodiment 20, wherein said cell stain is selected from the group consisting of a white blood cell differential indicator, an apoptosis indicator.
23. A method according to embodiment 20, wherein said reagent bound to said solid support is selected from the group consisting of an immobilized enzyme, an immobilized substrate, a plasma protein bead, an antibody bead, an antigen bead and an ELISA assay.
24. A method according to embodiment 20, wherein said chemical indicator is selected from the group consisting of a color indicator, a turbidity indicator, a pH indicator, an adsorption indicator, an emission indicator and a chemical reaction indicator.
25. A method according to embodiment 20, wherein said biological cell indicator is selected from the group consisting of a cell cycle stage indicator, a cell proliferation indicator, a cytokine indicator, a metabolic indicator and an apoptosis indicator.
26. A method according to embodiment 20, wherein said at least one reagent comprises at least two reagents.
27. A method according to embodiment 26, wherein said at least two reagents comprise at least one of:
- a. a cell surface marker and a cell element stain;
  - b. a cell surface marker and a plasma protein bead assay;
  - c. a cell surface marker and a solution change marker;
  - d. a cell element stain and a plasma protein bead assay; and
  - e. a cell element stain and a solution change marker.
28. A method according to embodiment 16, wherein the biological condition is selected from blood diseases such as leukemia, thrombocytopenia immune system disorders, local infections, urinary tract disorders, autoimmune diseases and sepsis.
29. A method for forming a chemical reaction in a stationary cartridge, the method comprising:
- a. storing at least one composition in said cartridge; and
  - b. activating at least one inflatable chamber to provide at least one pressure force to said at least one composition thereby inducing said chemical reaction.
30. A method according to embodiment 29, wherein said cartridge is a valveless cartridge.
31. A method according to embodiment 29, wherein said at least one composition comprises at least two compositions.
32. A method according to embodiment 29, wherein said at least one pressure force is a positive pressure force.
33. A method according to embodiment 29, wherein said at least one pressure force is a negative pressure force.
34. A method according to embodiment 29, wherein said at least one pressure force comprises at least one positive pressure force and at least one negative pressure force.
35. A method according to embodiment 34, wherein said at least one positive pressure force and at least one negative pressure force comprise alternating positive and negative pressure forces.
36. A method according to embodiment 29, wherein said at least one inflatable chamber comprises two one inflatable chambers.
37. A method according to embodiment 29, wherein said chemical reaction comprises at least one intermediate.
38. A method according to embodiment 29, wherein said at least one pressure force is provided sequentially to a several combinations of compositions of said at least one composition.
39. A method according to embodiment 29, further comprising introducing a specimen to said cartridge before said activating step.
40. A method according to embodiment 39, wherein said specimen is a bodily sample.
41. A method according to embodiment 40, wherein said chemical reaction provides a flow cytometric assay result to said bodily sample.
42. A method according to embodiment 41, wherein said chemical reaction is for determining a biological condition in a mammalian subject.
43. A method according to embodiment 42, further comprising:
- c) incubating a specimen from the subject in said cartridge for a predetermined period of time; and
  - d) receiving an indication responsive to at least one reporter element thereby providing the indication of the biological condition in said subject.
44. A method according to embodiment 43, wherein the biological condition is selected from blood diseases such as leukemia, thrombocytopenia immune system disorders, local infections, urinary tract disorders, autoimmune

diseases and sepsis.

45. A method according to embodiment 44, wherein said at least one composition disposed in said cartridge comprises a sepsis biomarker.

46. A method according to embodiment 45, wherein said biomarker comprises at least one of CD64 and CD163.

47. A method according to embodiment 43, wherein said indication is quantitative.

48. A method according to embodiment 43, wherein the sample is of a volume of less than 200 microliters ( $\mu\text{L}$ ).

49. A method according to embodiment 29, wherein the method is completed within twenty minutes.

50. A method according to embodiment 49, wherein the method is completed within fifteen minutes.

51. A method for determining a biological condition in a mammalian subject, the method comprising:

a) incubating a specimen from the subject with at least one composition in a stationary cartridge according to embodiment 1, for a predetermined period of time to form at least one reaction product, when said subject has said biological condition; and

b) receiving an indication of said at least one reaction product responsive to at least one reporter element in said method thereby providing the indication of the biological condition in said subject.

## Claims

1. A biological assay system comprising:

a cartridge for sample processing, the cartridge comprising

a sample chamber (1404);

a first blister comprising a first composition (1420);

a second blister comprising a second composition (1422);

a third blister comprising a third composition (1424);

a first mixing chamber (1412);

a second mixing chamber (1411);

first bellows (1415);

second bellows (1417);

a tortuous conduit (1413) connecting the first and second mixing chambers;

a chamber for processed sample (1430); and

a reading zone (1450), and

a reader assembly unit (1200), the unit comprising:

a cartridge handling unit (1228) for insertion of said cartridge;

an optical illuminator (1462); and

an optical detector (1470),

wherein

the sample chamber, first blister and second blister are each connected to the first mixing chamber;

the first bellows is connected to the second mixing chamber;

the chamber for processed sample is connected to the first mixing chamber;

the chamber for processed sample is connected to the reading zone; and

the optical detector comprises detection elements for independent detection of different wavelengths.

2. The system of claim 1, wherein said cartridge is disposable.

3. The system of claim 1, wherein at least one of said first composition, said second composition, and said third composition comprises at least one of:

a. at least one target antibody;

b. at least one positive control identifying antibody;

c. at least one negative control identifying detection moiety;

d. a lysis reagent;

e. a diluent; and

f. reference beads.

4. The system of claim 3, wherein:

- 5 a. said target antibody comprises CD64 antibody; and  
 b. said positive control identifying antibody is CD163.

5. The system of claim 1, wherein said reader assembly unit further comprises a data processor [2036] and a display [1215].

10 6. A method for performing a biological assay in the biological assay system of any of claims 1-5, the method comprising:

- 15 introducing a sample to the sample chamber;  
 inserting the cartridge into the cartridge handling unit;  
 pressing the first blister;  
 pressing and releasing the first bellows;  
 pressing the second blister;  
 pressing and releasing the first bellows;  
 pressing the third blister;  
 20 pressing and releasing the first bellows thereby forming a processed sample in the first mixing chamber;  
 pressing the second bellows thereby transferring the processed sample to the processed sample chamber;  
 illuminating the reading zone by the optical illuminator;  
 transferring the processed sample through the reading zone;  
 detecting optical signals from the reading zone using the optical detector; and  
 25 processing the detected optical signals.

7. The method of claim 6, wherein the steps of illuminating the reading zone and the step of transferring the sample through the reading zone are performed at least partially in parallel.

30 8. The method of claim 6, wherein the pressing steps are performed automatically within the reader assembly unit and the inserting the cartridge step is performed prior to the pressing steps.

9. The method of claim 6, wherein said assay is indicative of a blood disease, an immune system disorder, a local infection, a urinary tract disorder, an autoimmune disease or sepsis.

35 10. The method of claim 9, wherein said blood disease is leukemia or thrombocytopenia.

11. The method of claim 6, wherein the assay is completed within 1 to 20 minutes and wherein the sample is of a volume of 10 to 200 microliters ( $\mu\text{L}$ ).

40 12. The method of claim 6, wherein said sample is a bodily sample selected from blood, serum, plasma, urine, saliva, cerebrospinal fluid (CSF), serous fluid, peritoneal fluid and synovial fluid blood.

13. The method of claim 12, wherein the bodily sample comprises a target moiety.

45 14. The method of claim 6, wherein at least one of said first composition, said second composition, and said third composition comprises at least one of:

- 50 a. at least one target antibody;  
 b. at least one positive control identifying antibody;  
 c. at least one negative control identifying detection moiety;  
 d. a lysis reagent;  
 e. a diluent; and  
 f. fluorescently-labeled beads.

55 15. The method of claim 14, wherein said first composition comprises CD64 and CD163 antibodies, said second composition comprises a lysis reagent and/or a diluent and said third composition comprises reference/calibration beads.

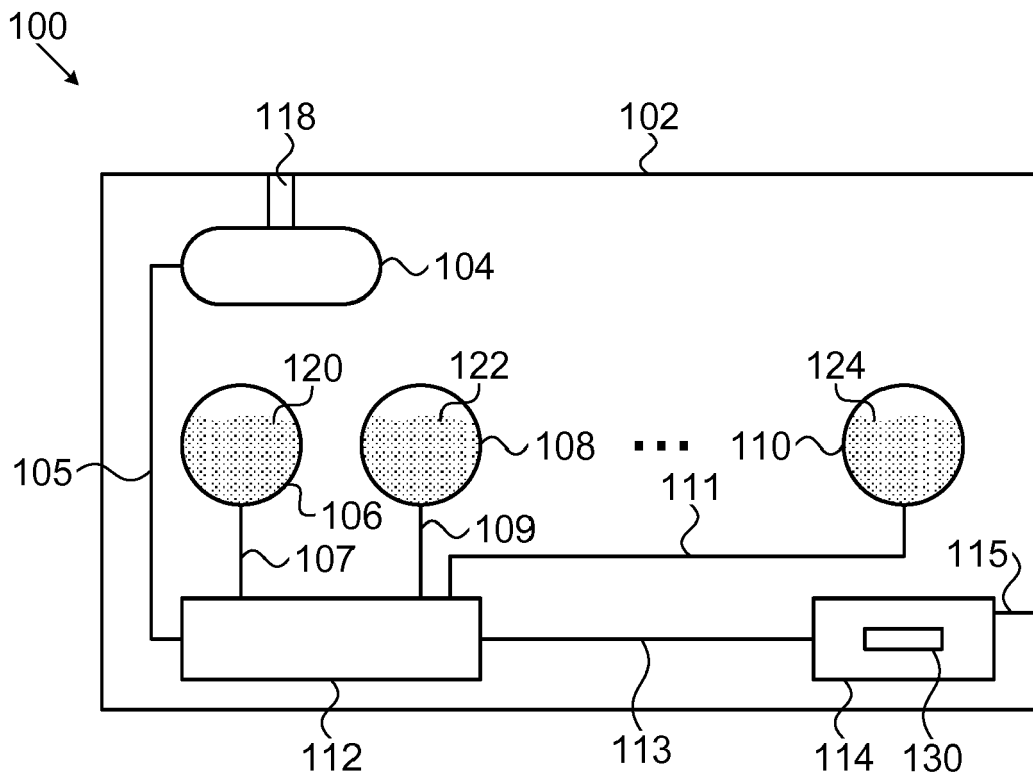

FIG. 1

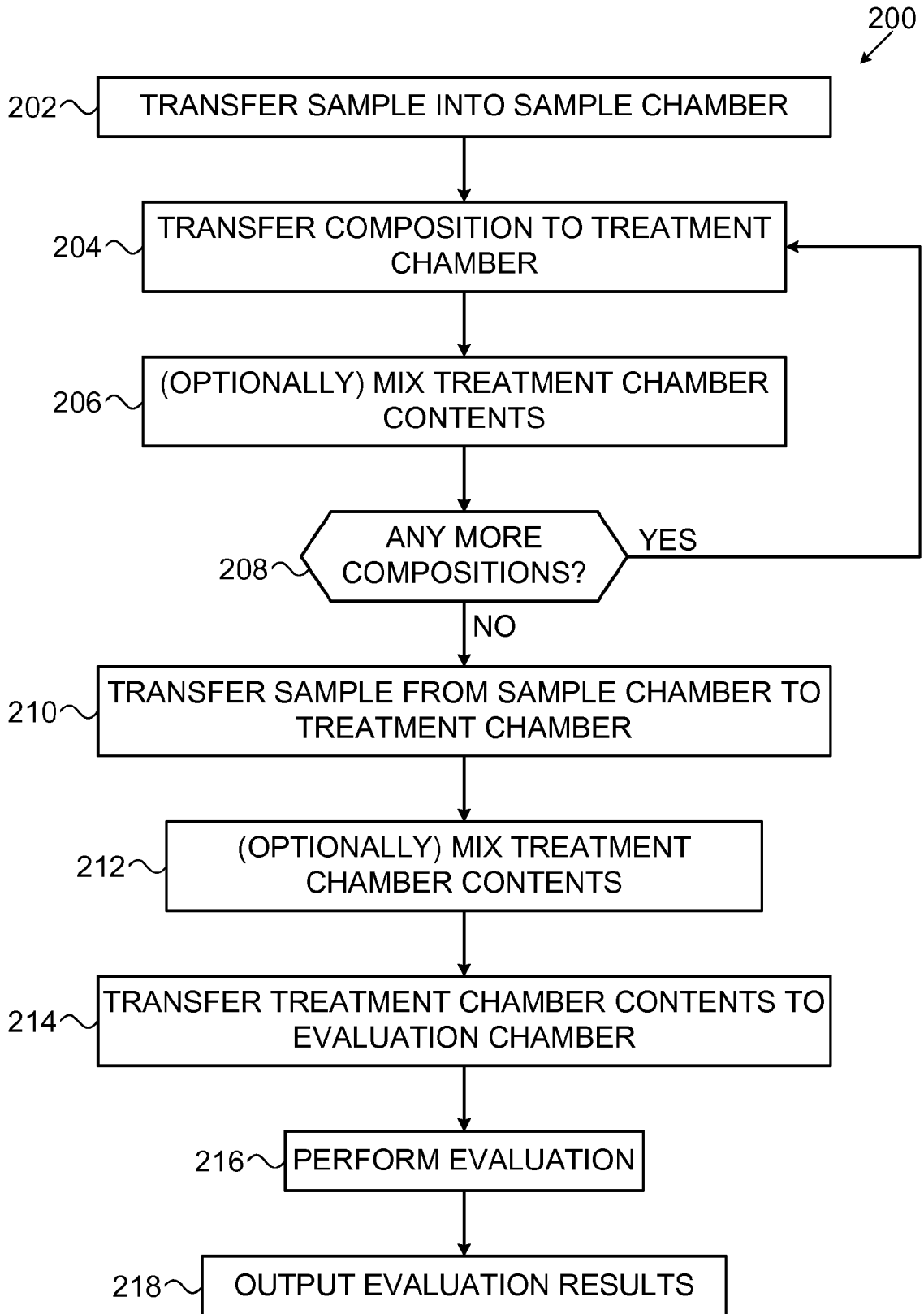

FIG. 2

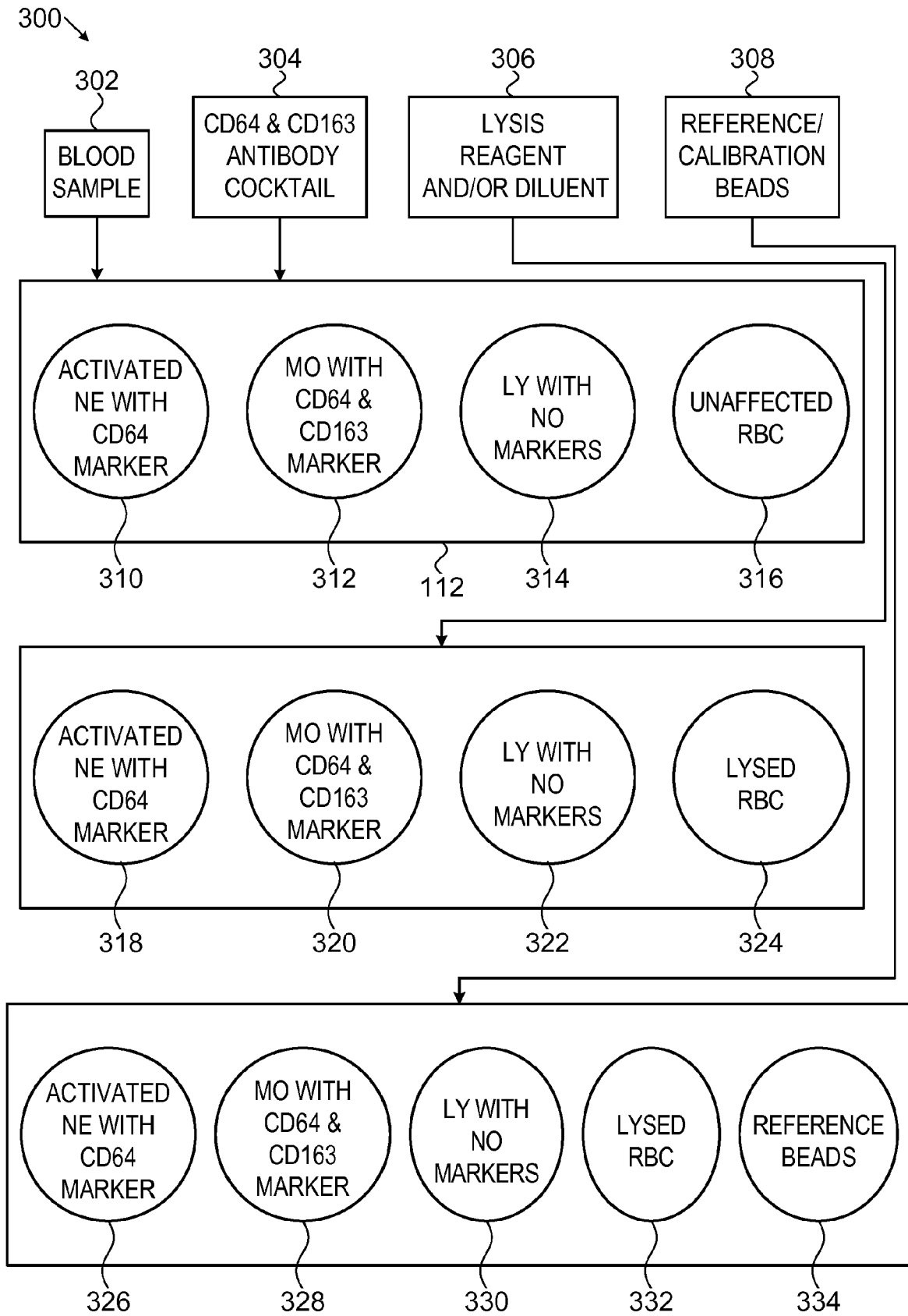

FIG. 3

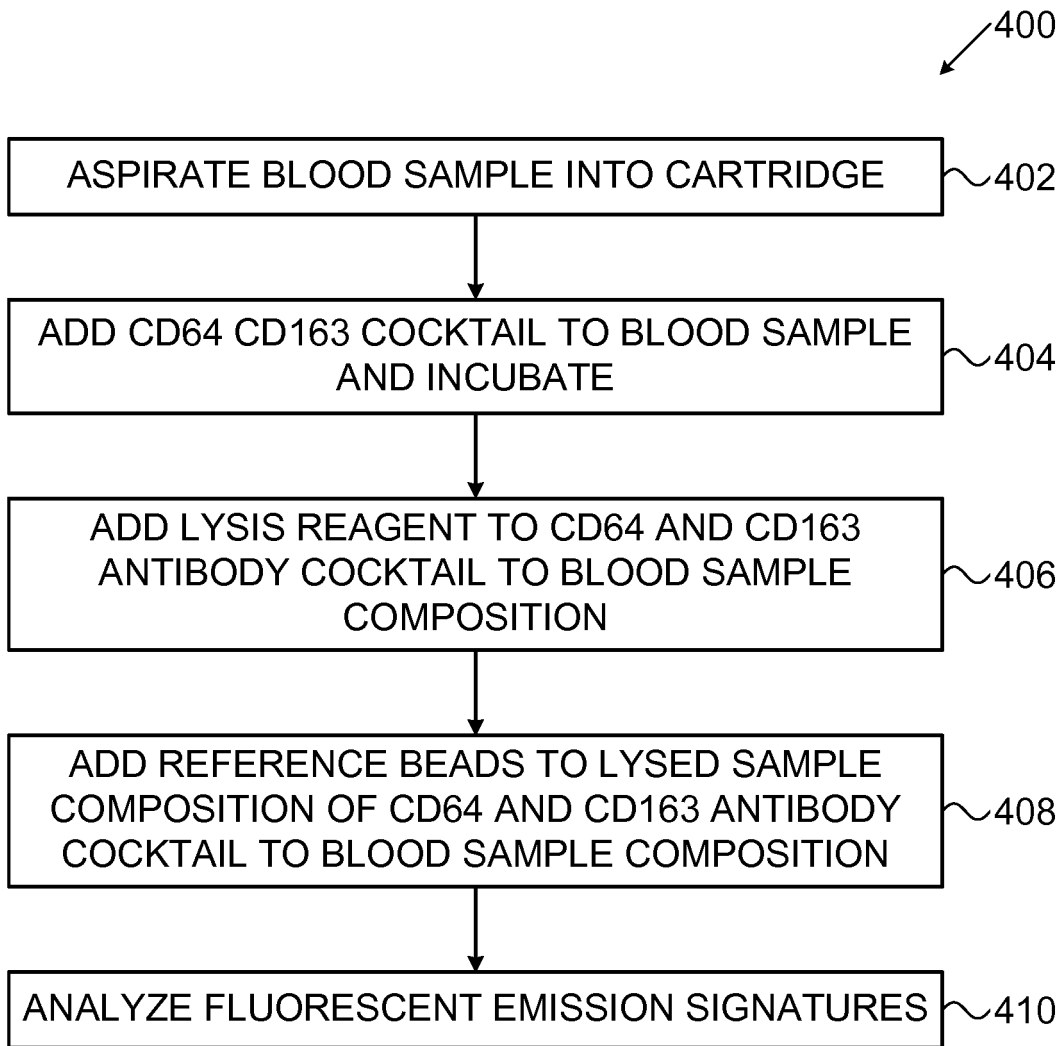

FIG. 4

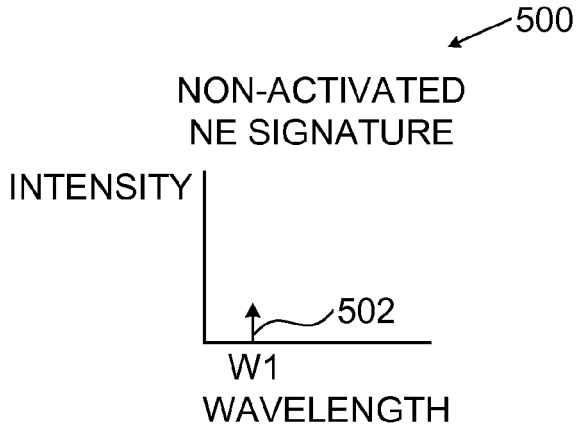

FIG. 5A

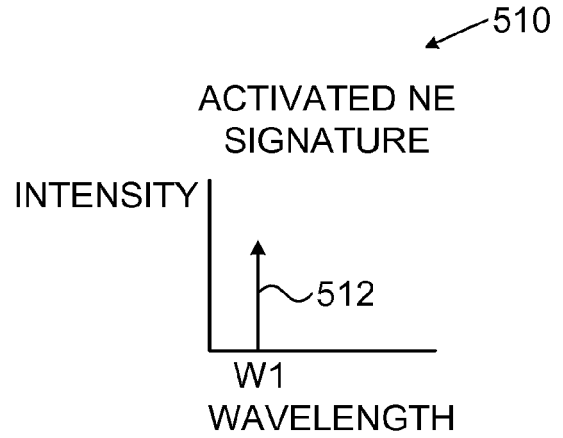

FIG. 5B

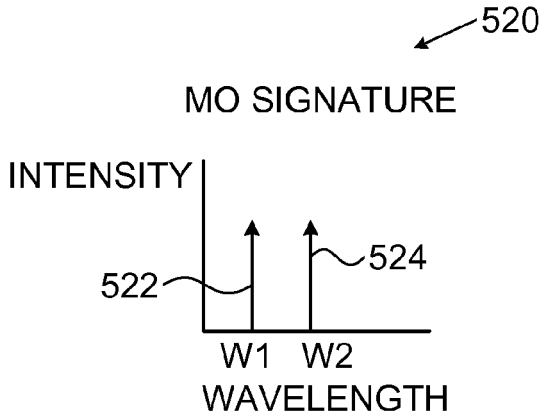

FIG. 5C

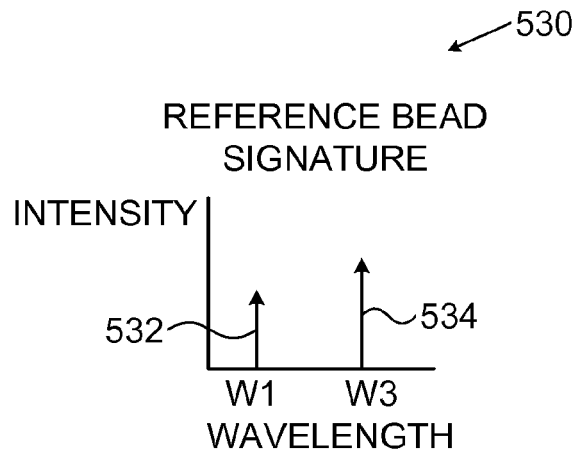

FIG. 5D

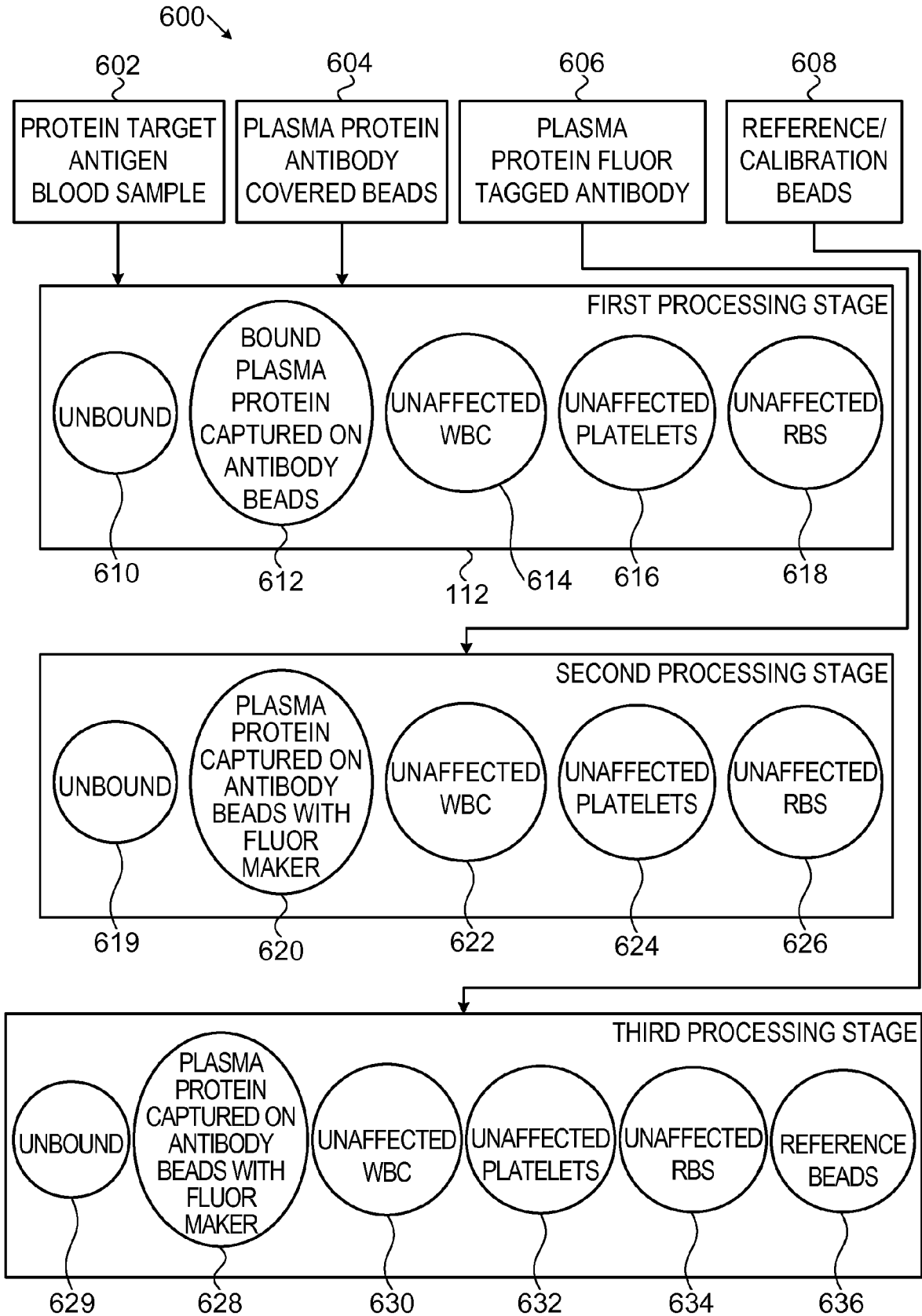

FIG. 6

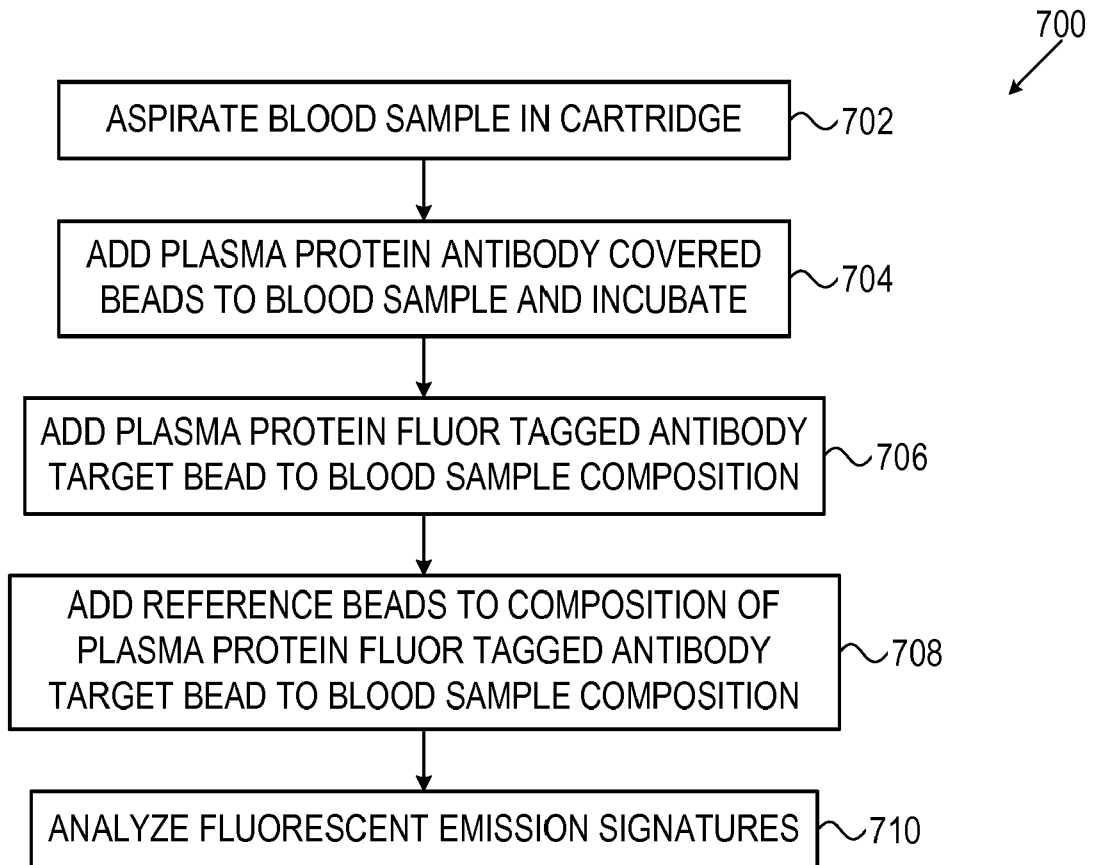

FIG. 7

PLASMA PROTEIN  
TARGET BEADS WITH NO  
TARGET BINDING (NO Ab)

800

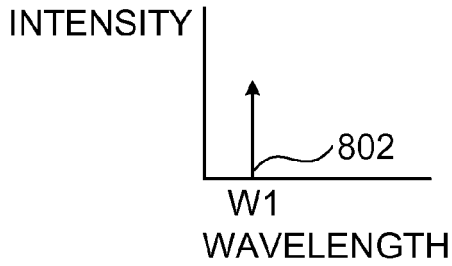

FIG. 8A

UNBOUND TAGGED TARGET  
ANTIBODY SIGNATURE

810

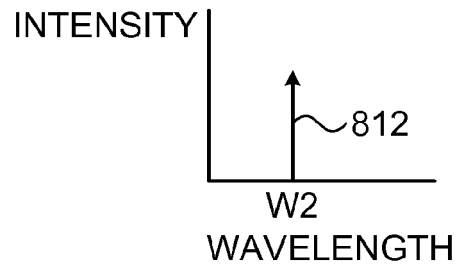

FIG. 8B

PLASMA PROTEIN TARGET  
BEADS WITH TARGET BINDING

820

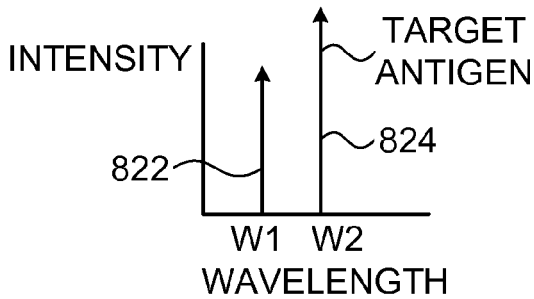

FIG. 8C

REFERENCE BEAD  
SIGNATURE

830

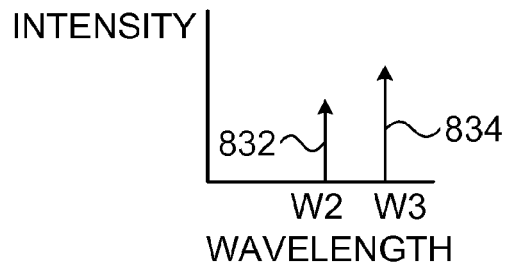

FIG. 8D

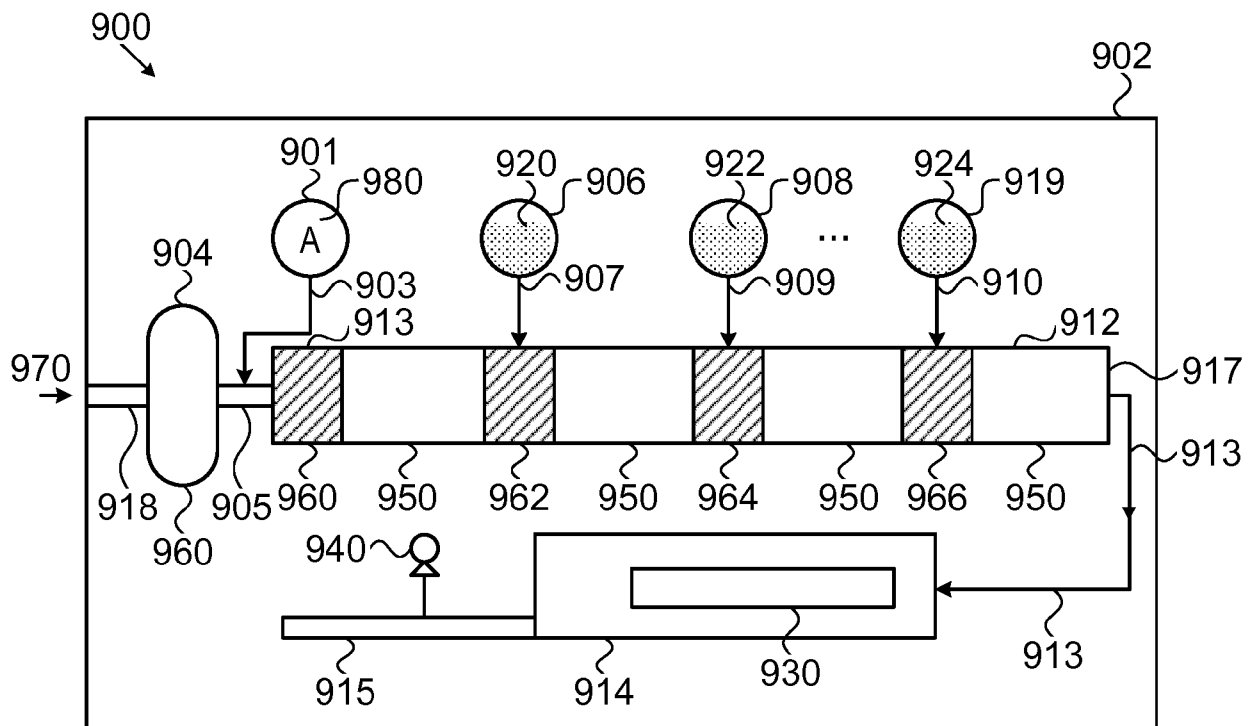

FIG. 9

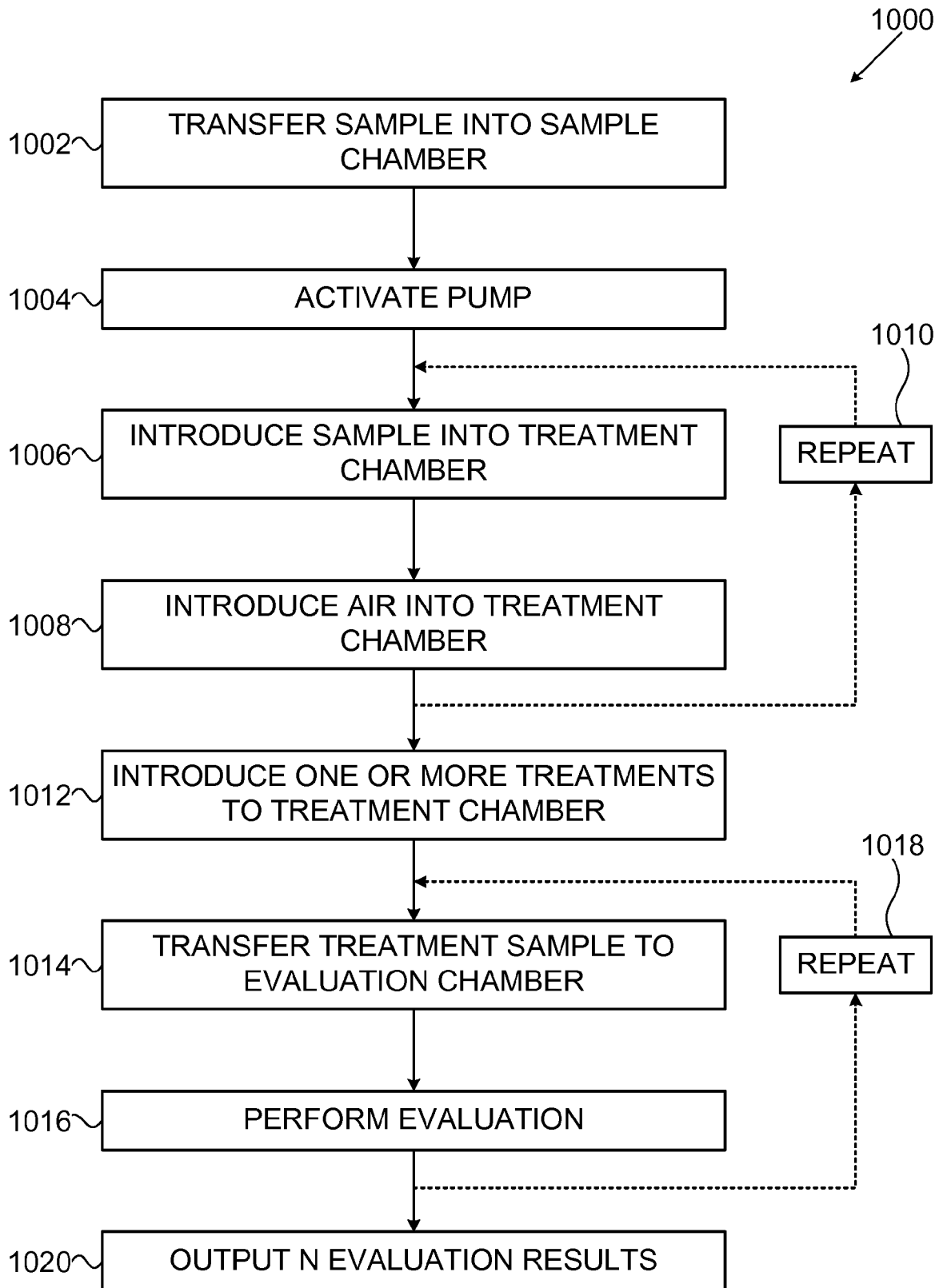

FIG. 10

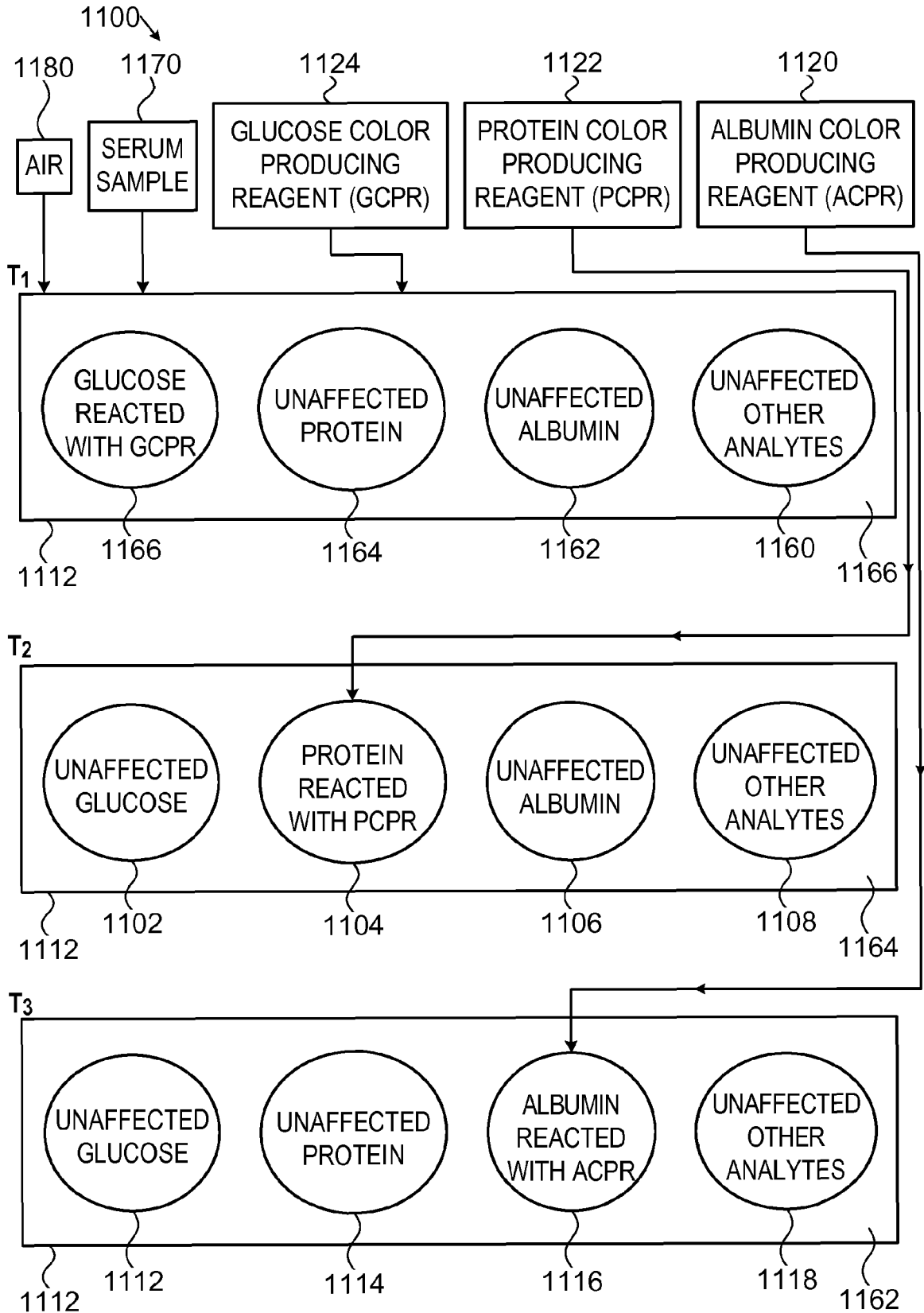

FIG. 11

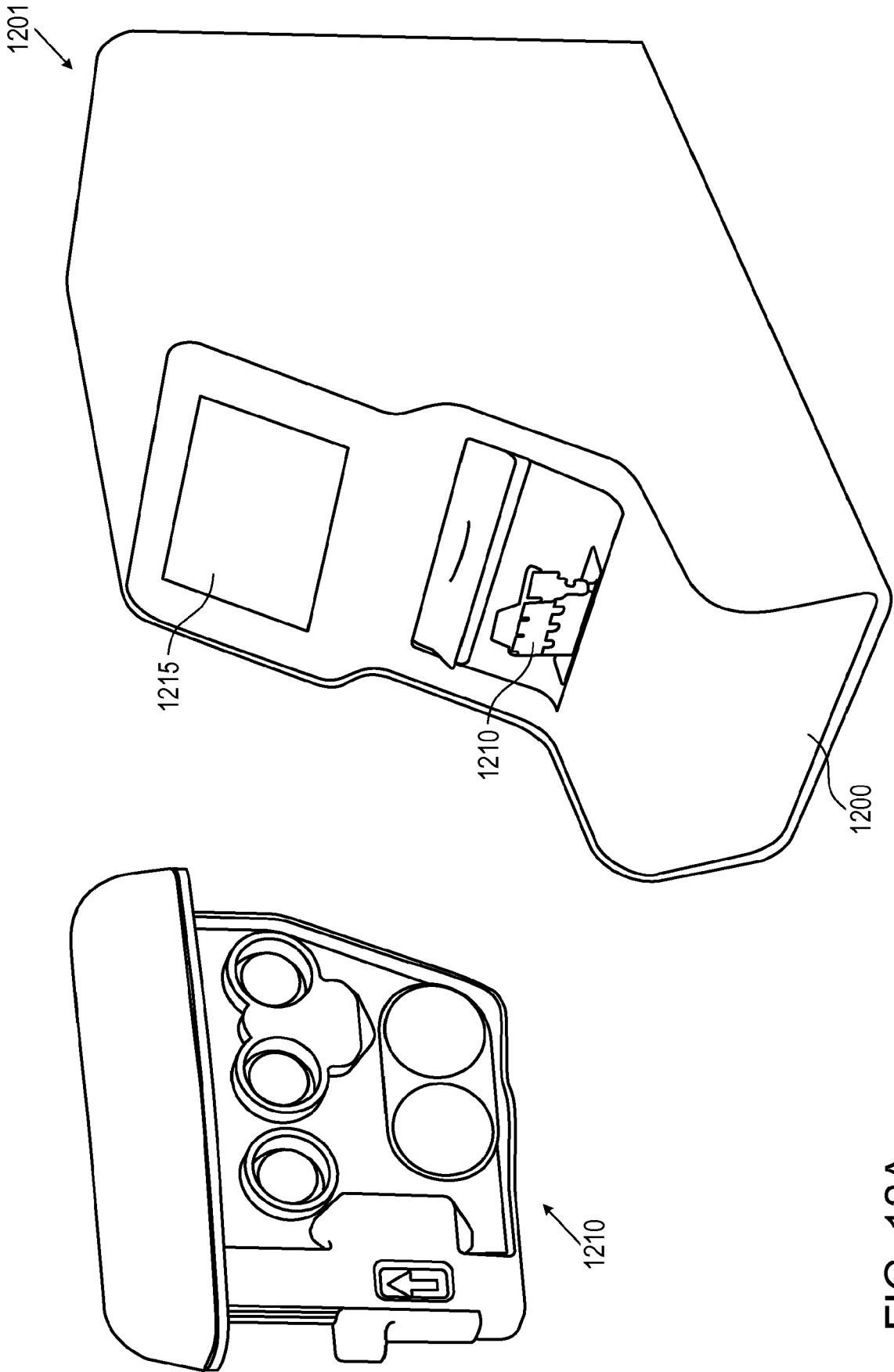

FIG. 12A

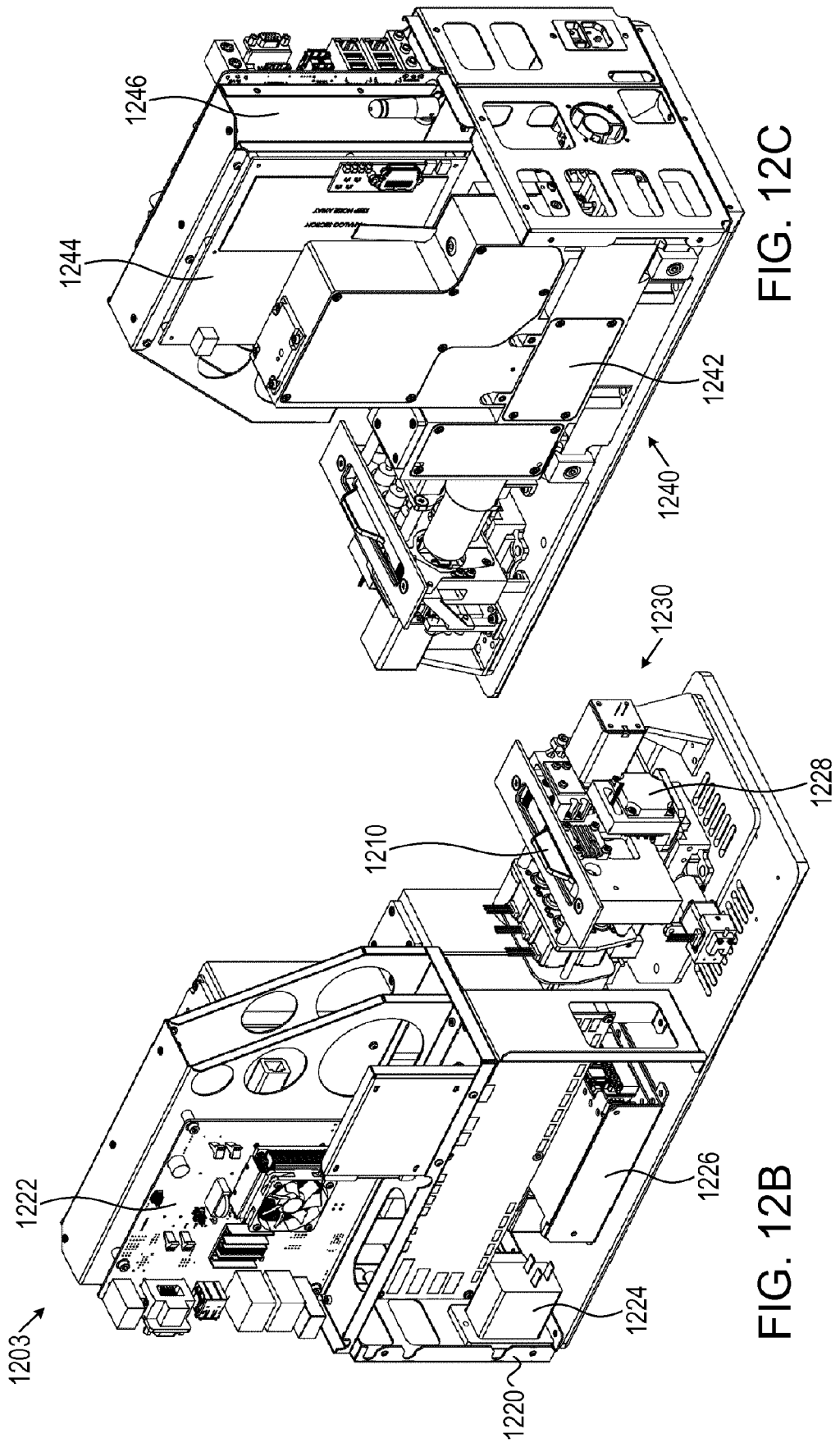
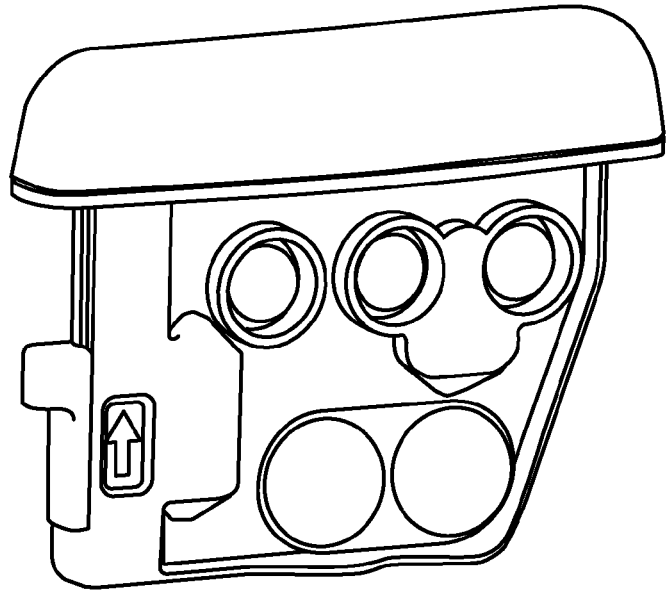

FIG. 12C

FIG. 12B

FIG. 13A



1300

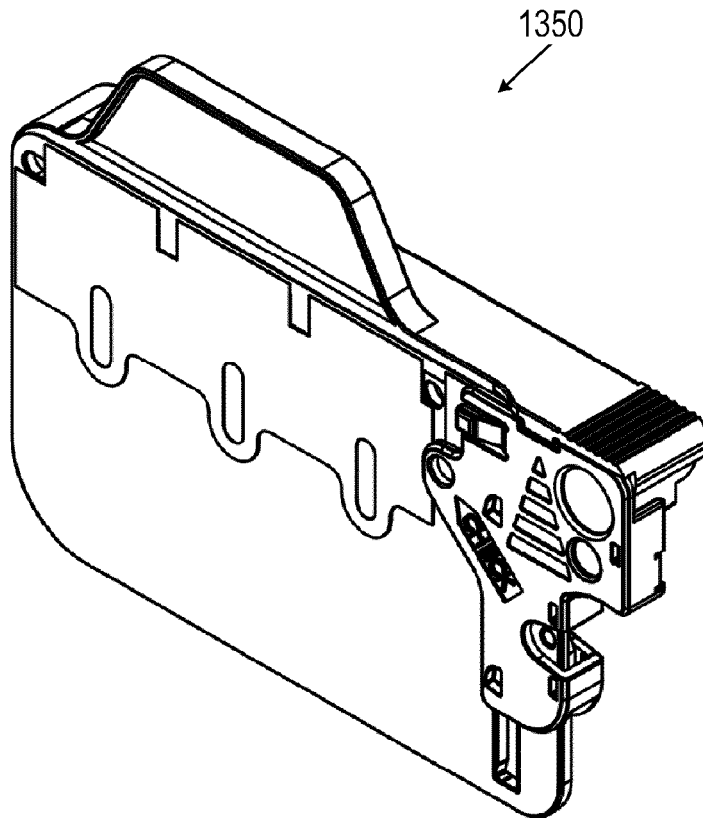

1350

FIG. 13B

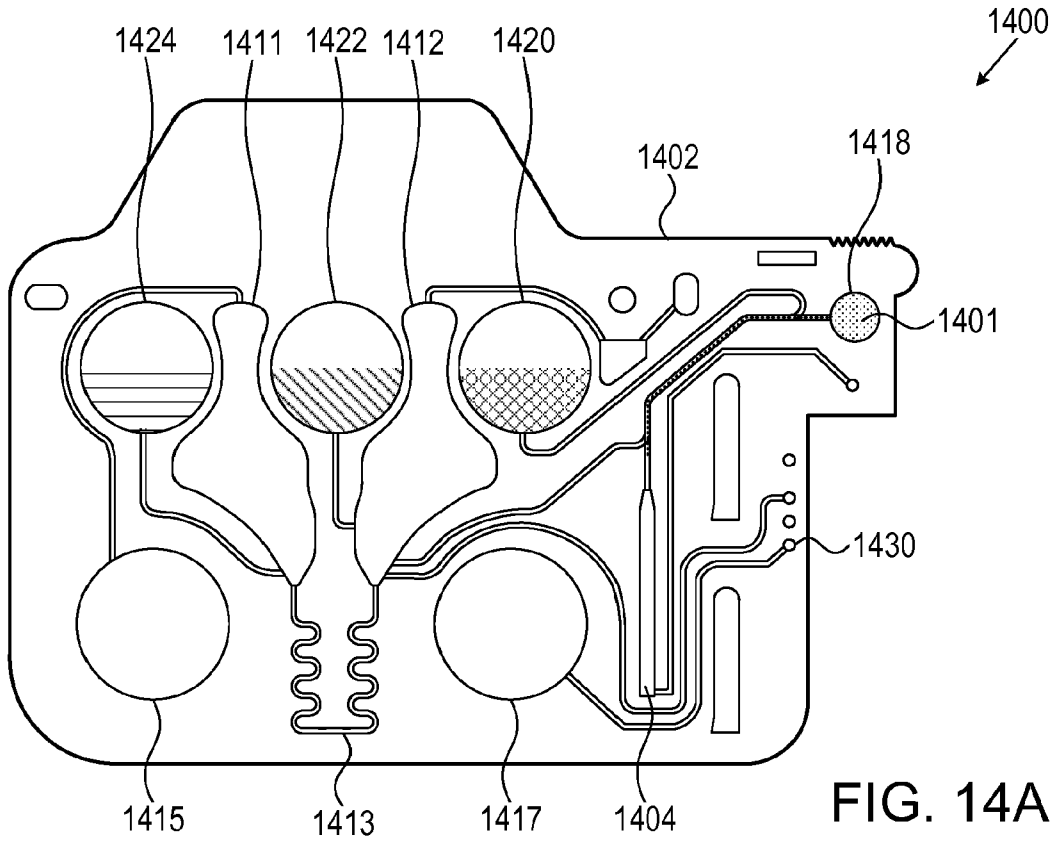

FIG. 14A

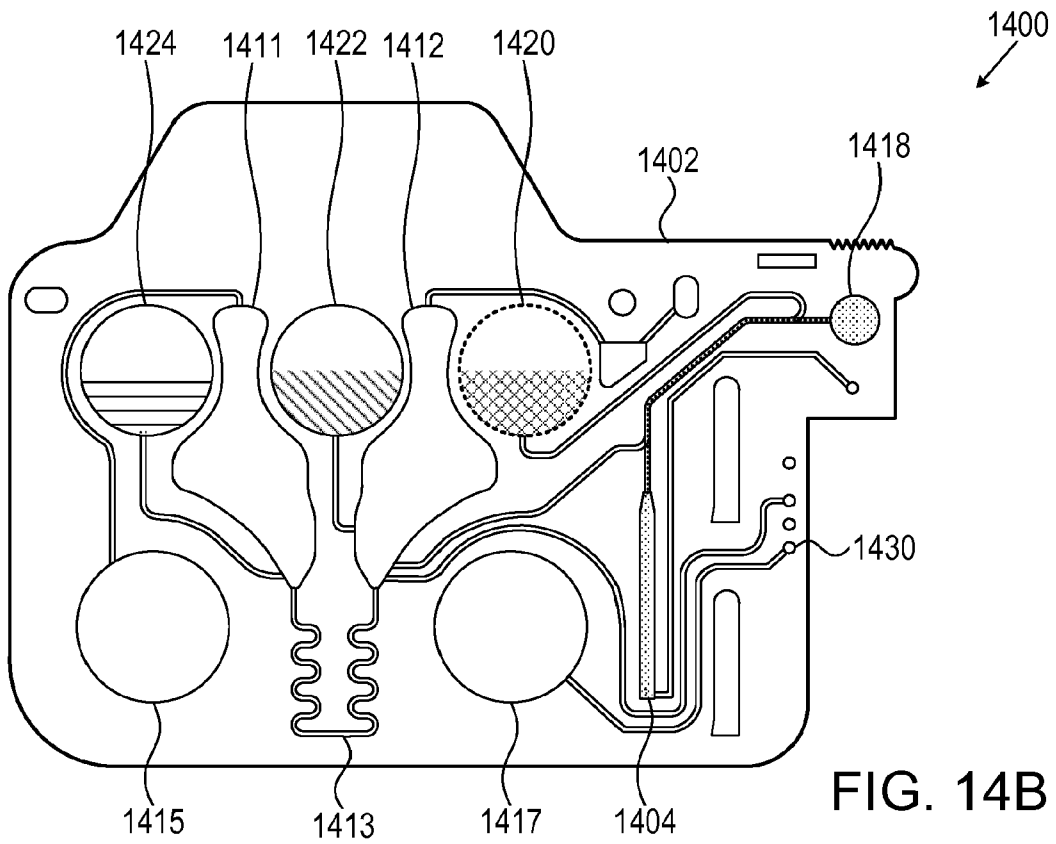

FIG. 14B

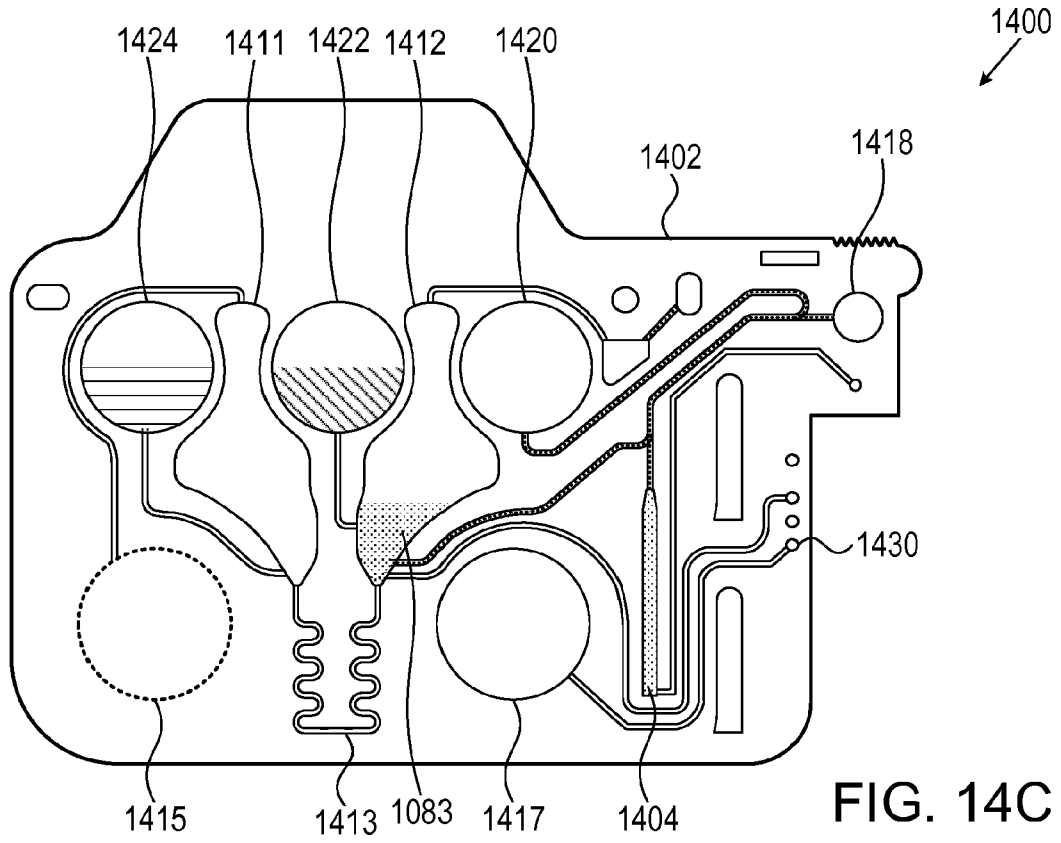

FIG. 14C

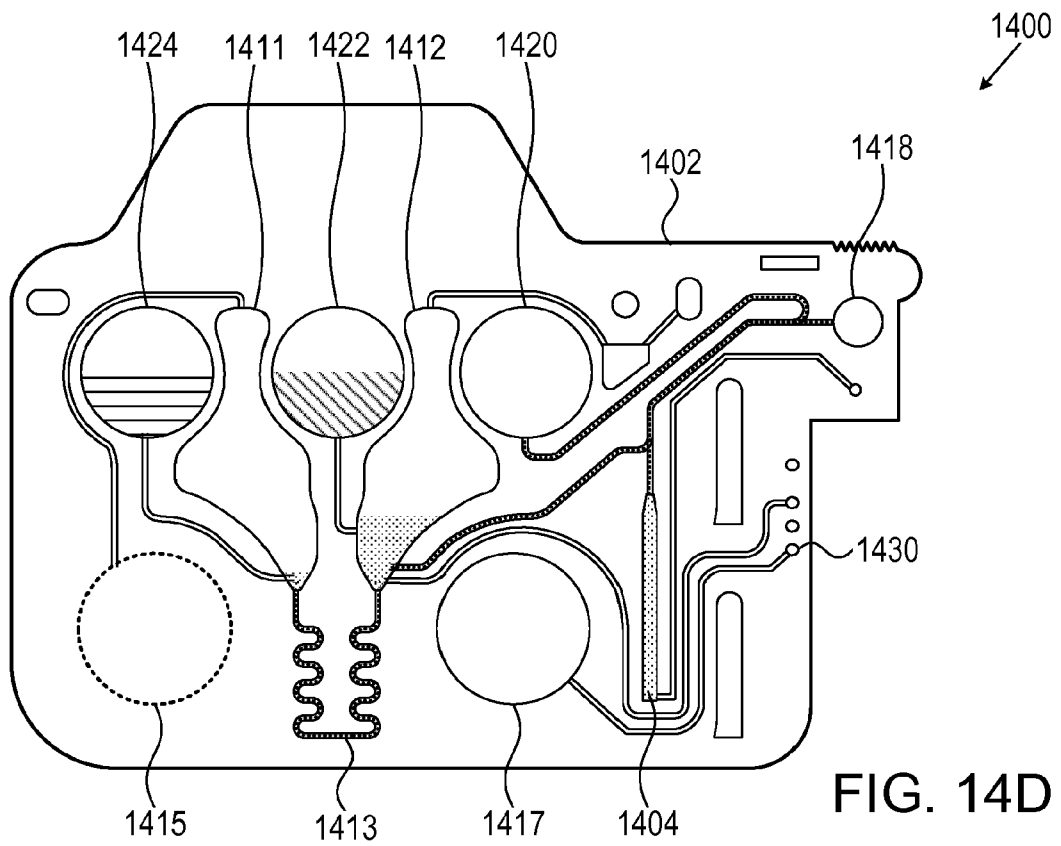

FIG. 14D

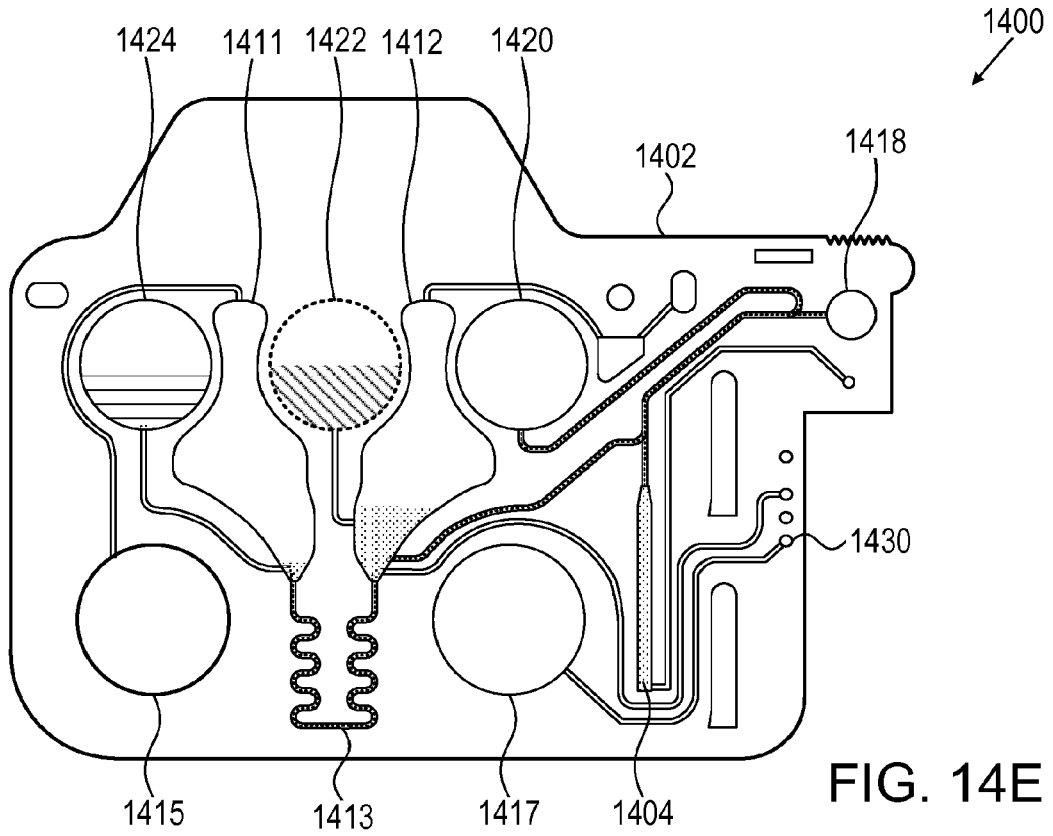

FIG. 14E

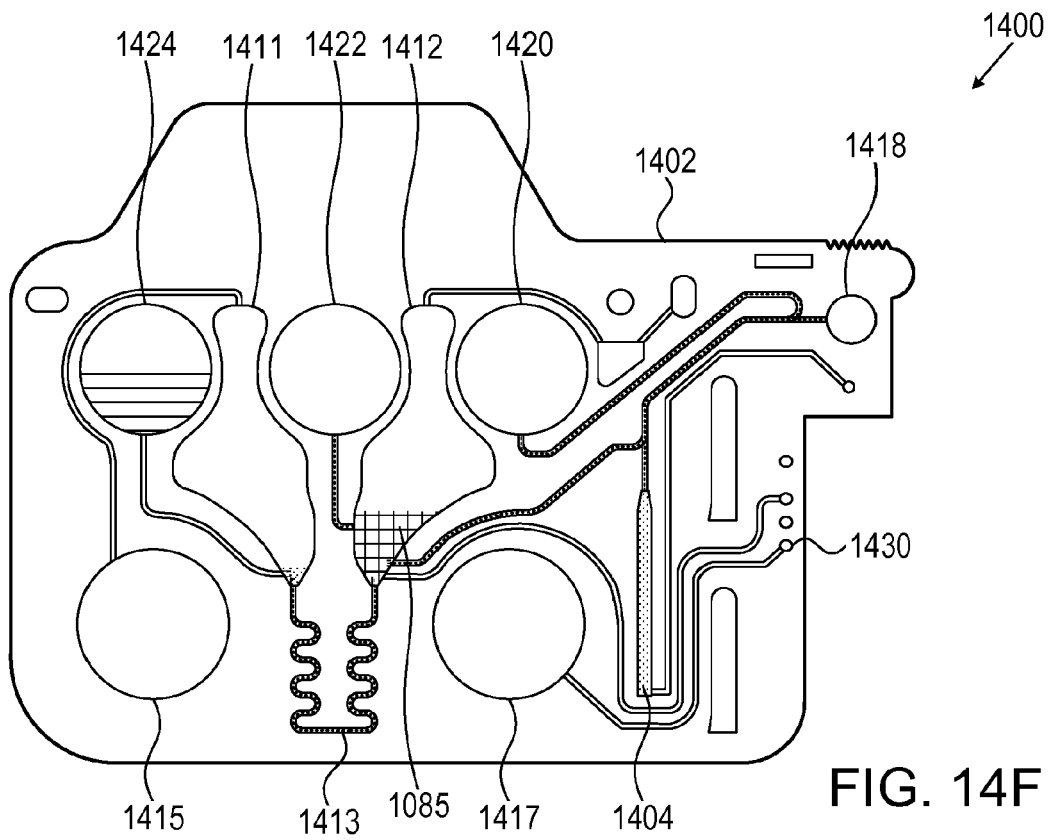

FIG. 14F

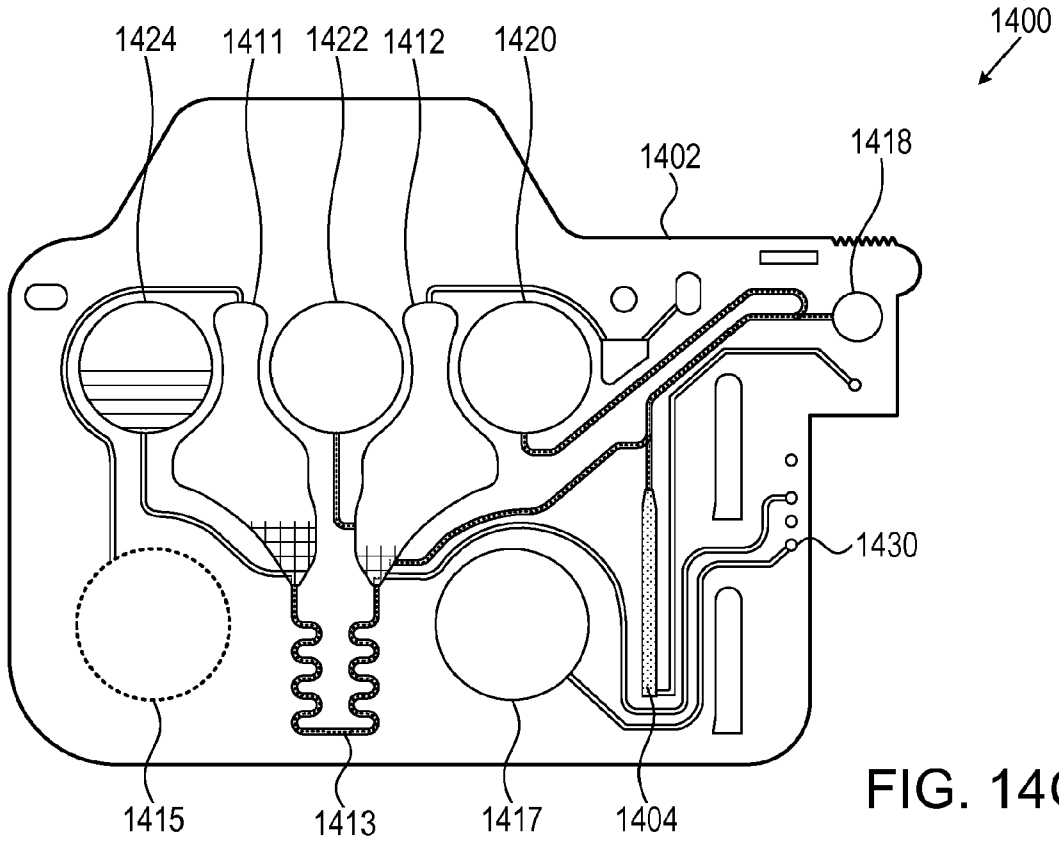

FIG. 14G

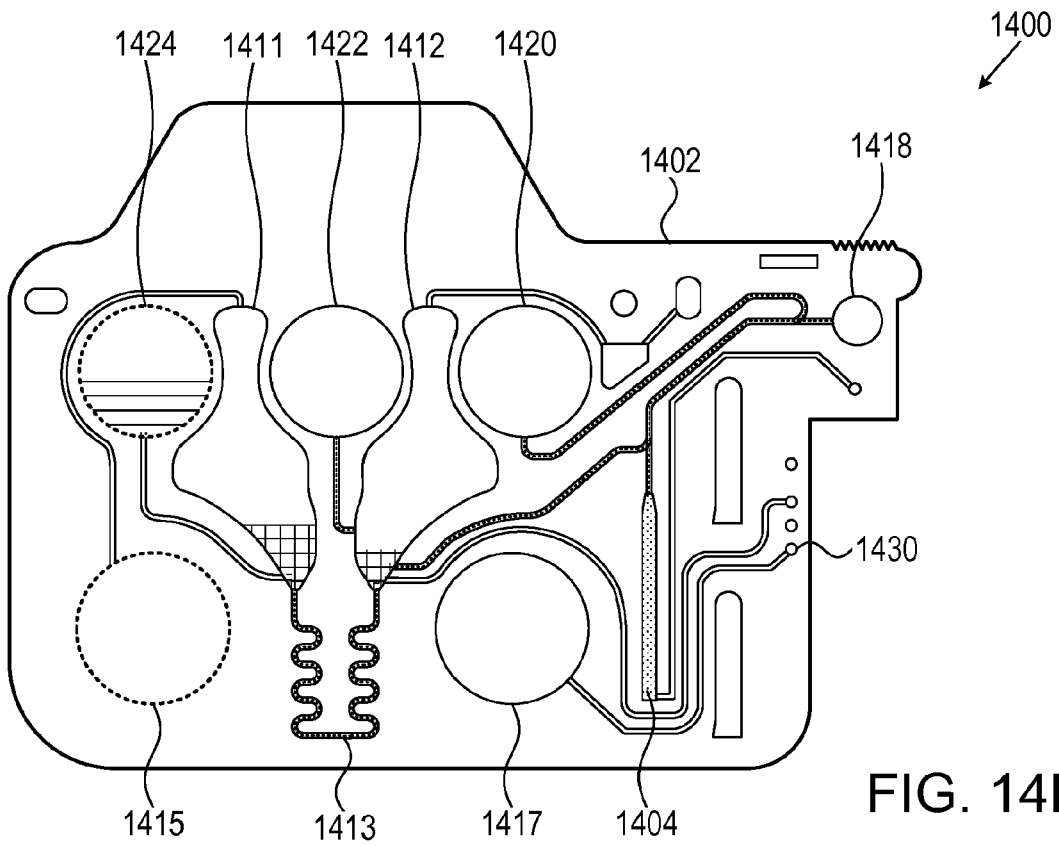

FIG. 14H

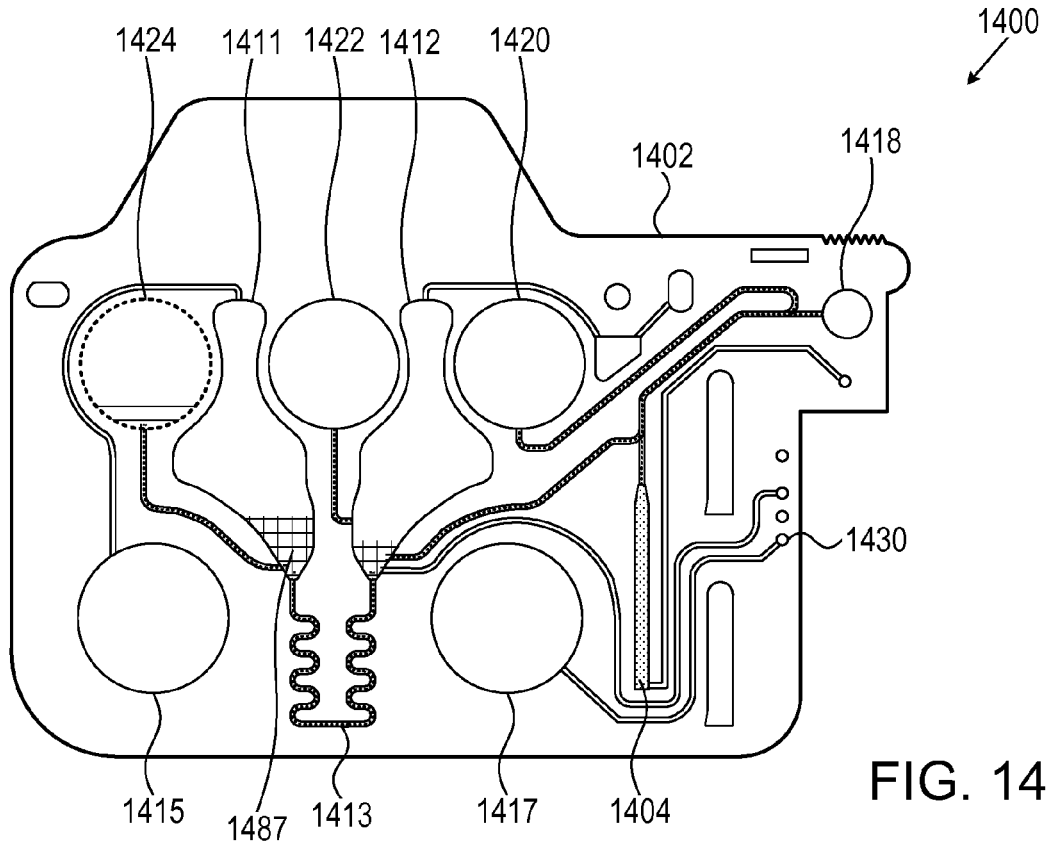

FIG. 14I

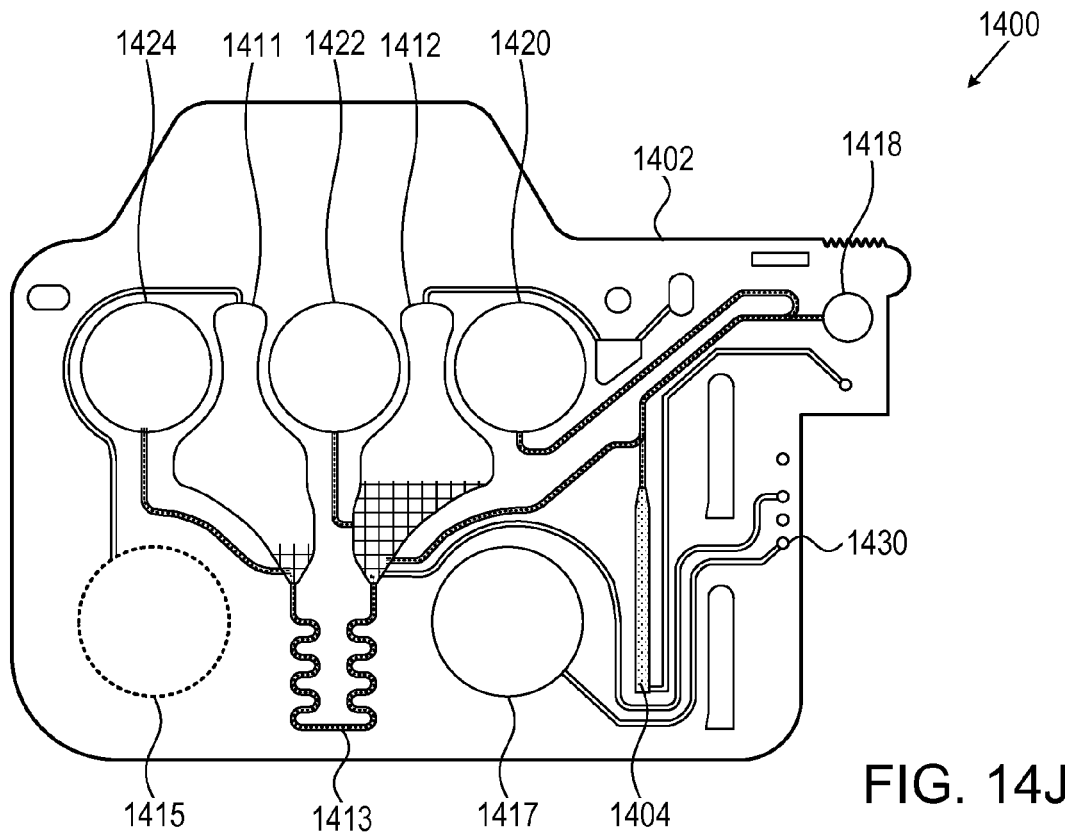

FIG. 14J

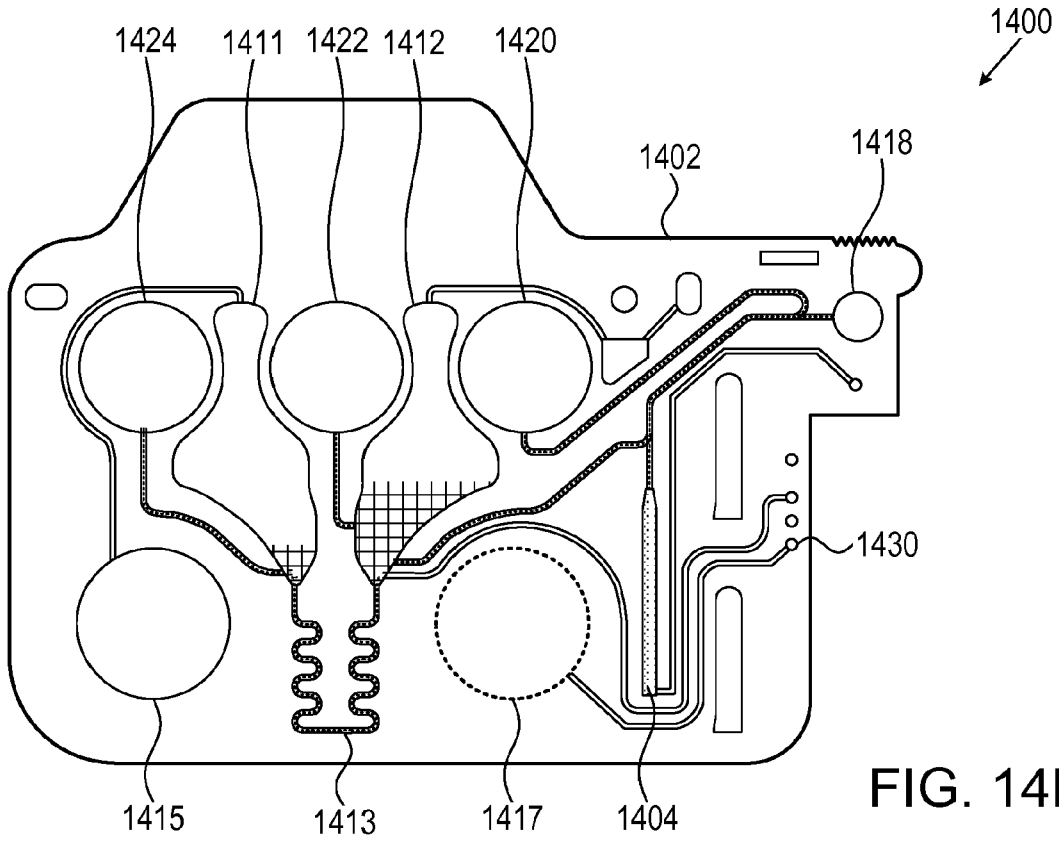

FIG. 14K

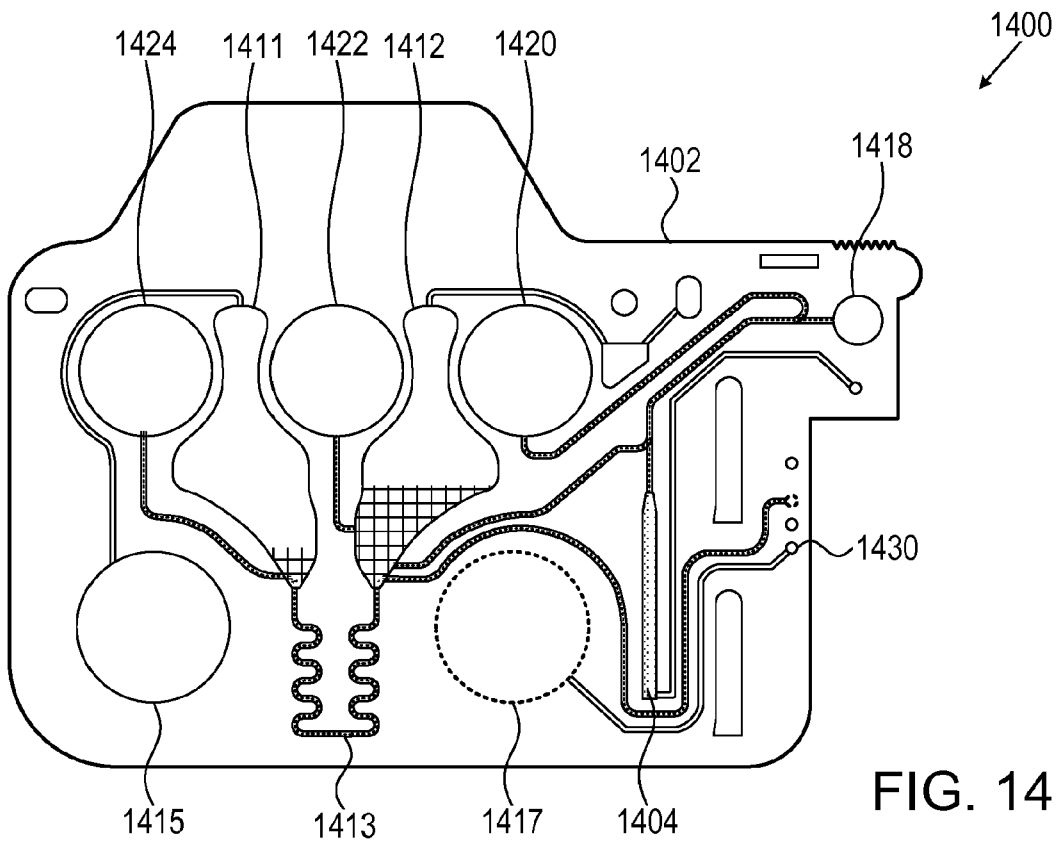

FIG. 14L

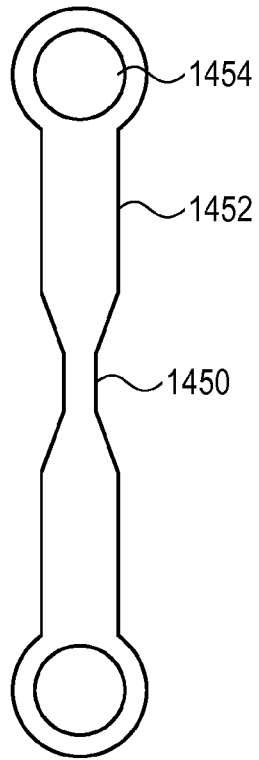

FIG. 14M

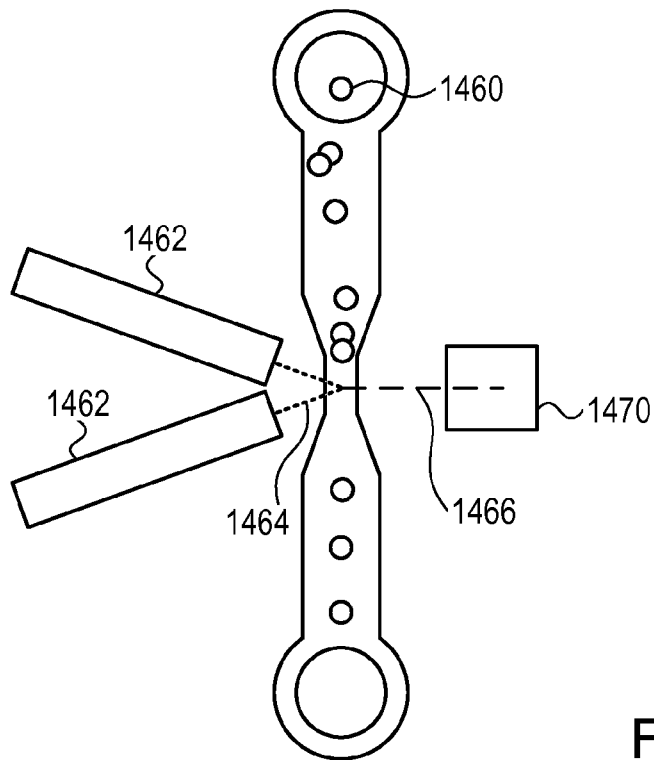

FIG. 14N

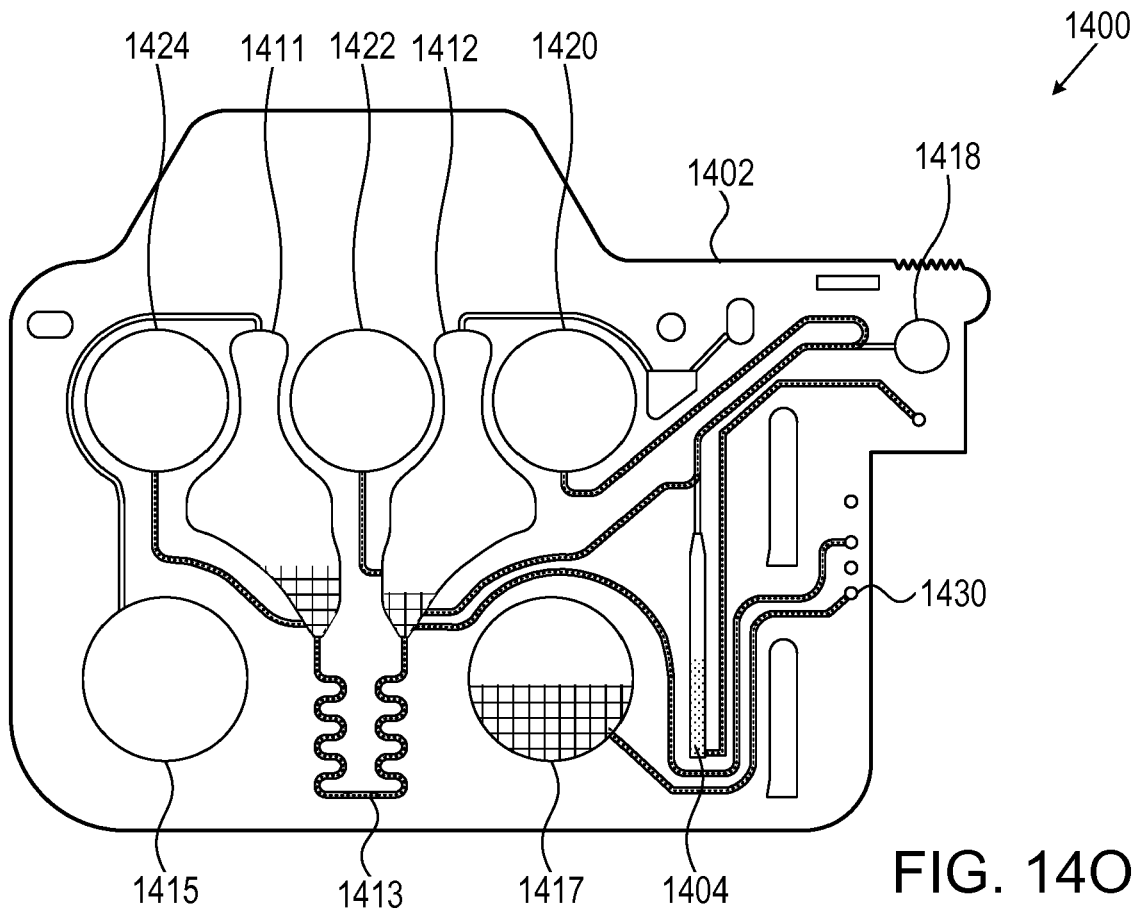

FIG. 140

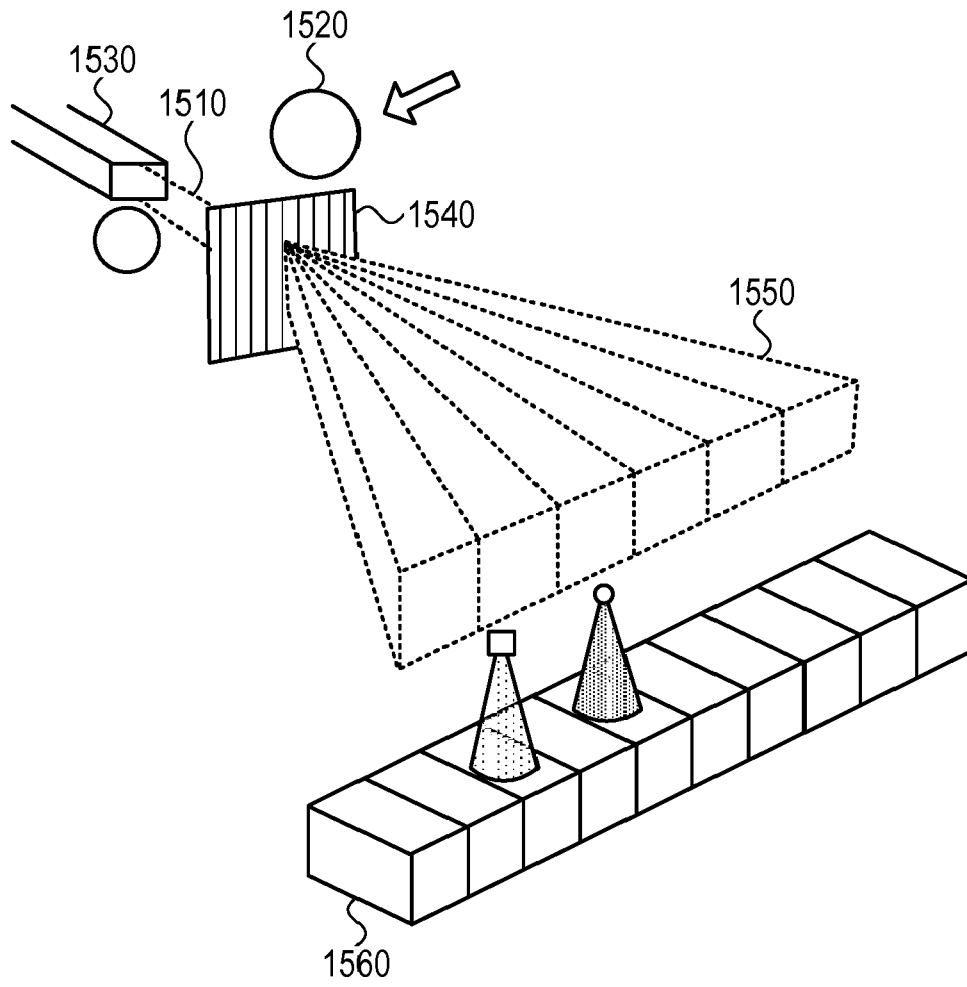

FIG. 15

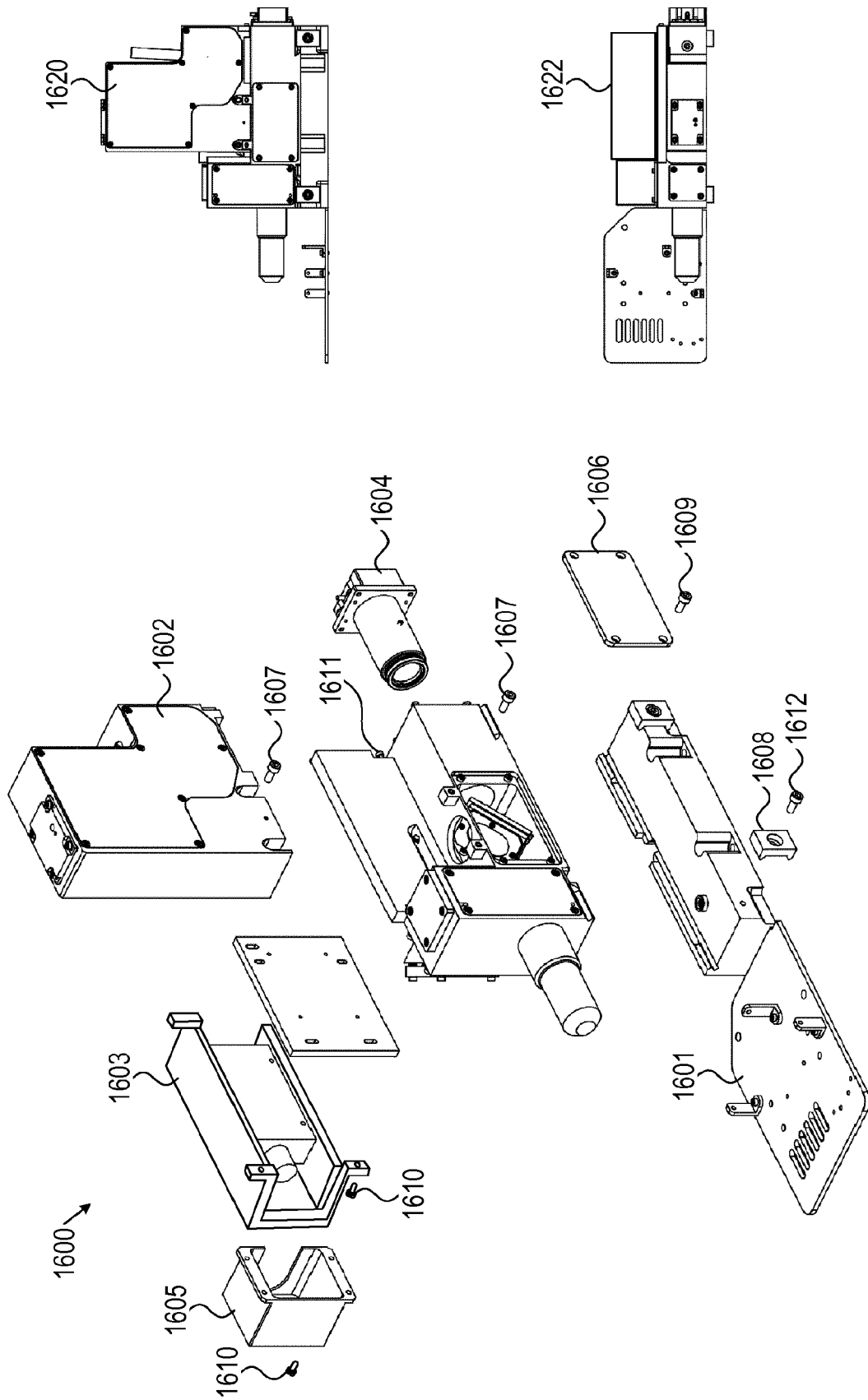

FIG. 16A

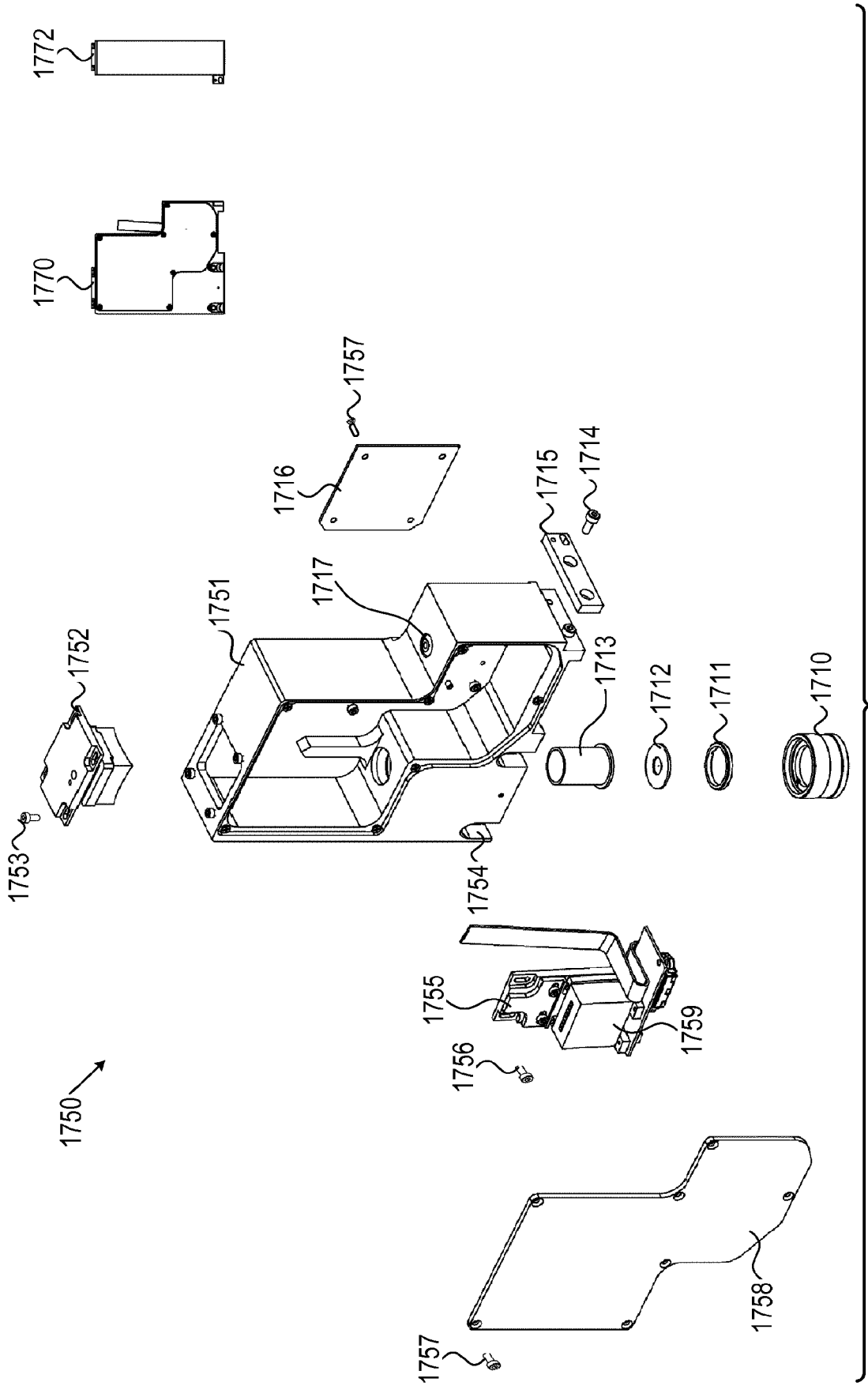

FIG. 17

FIG. 18A

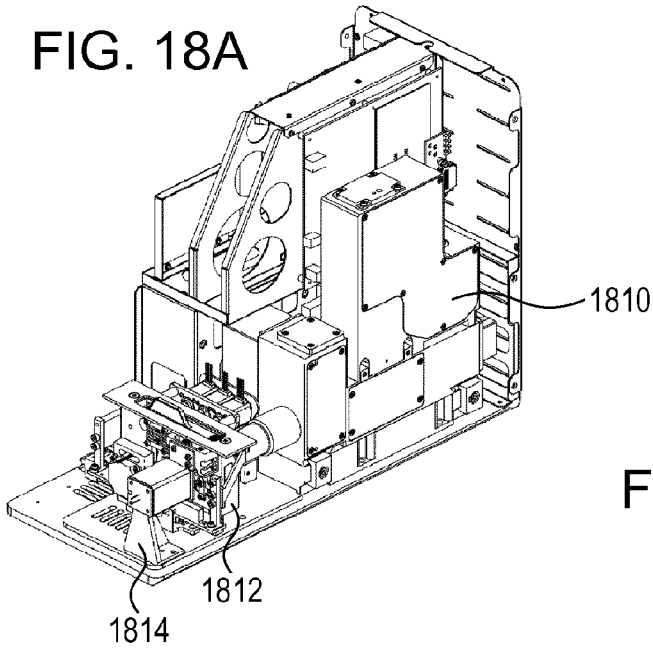

FIG. 18B

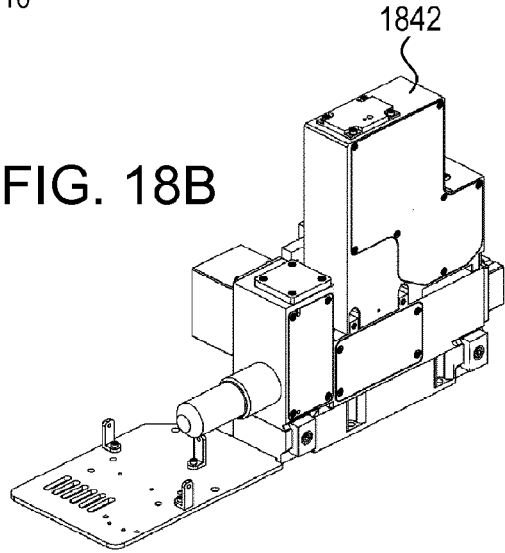
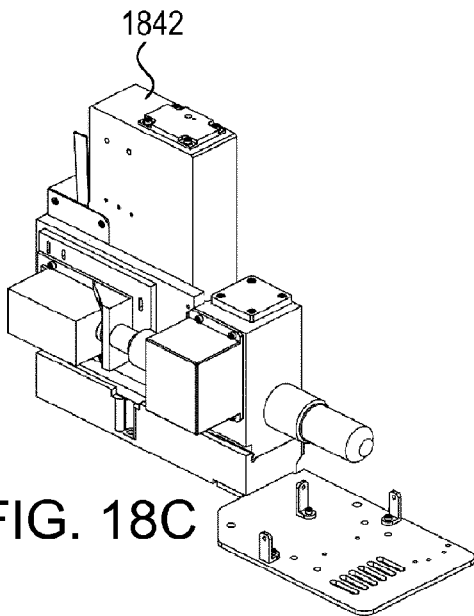

FIG. 18C



1830

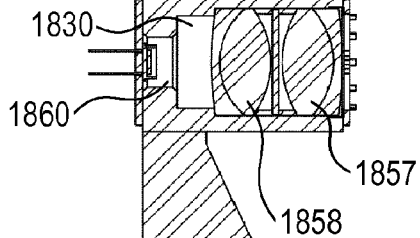
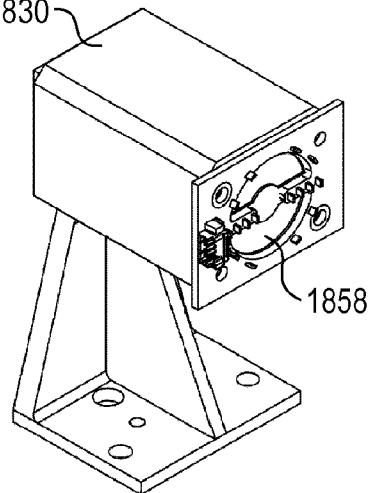

FIG. 18E

FIG. 18D

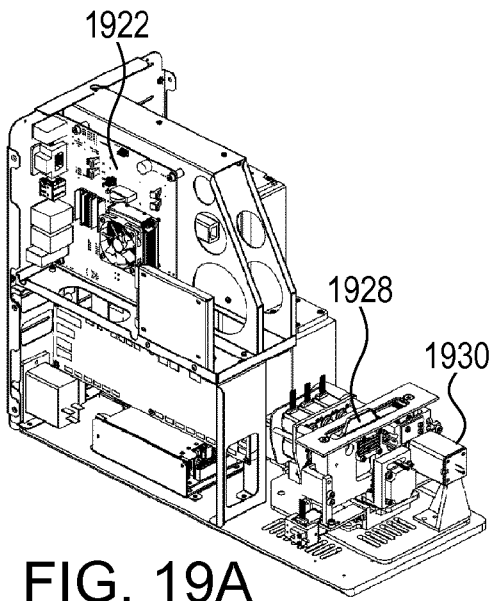

FIG. 19A

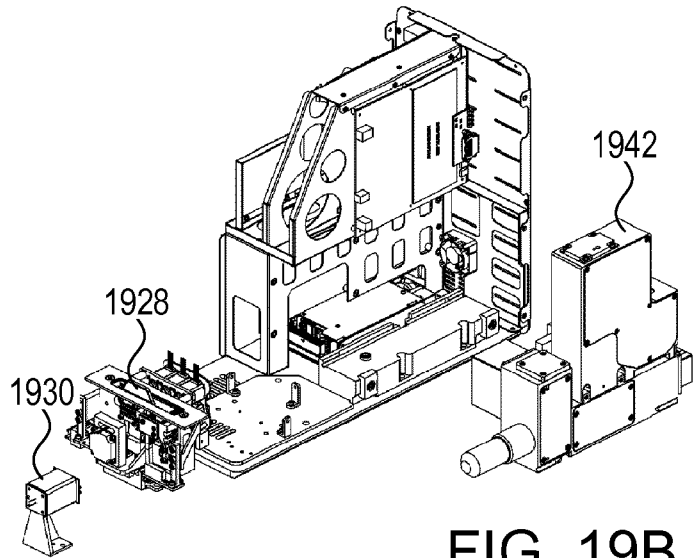

FIG. 19B

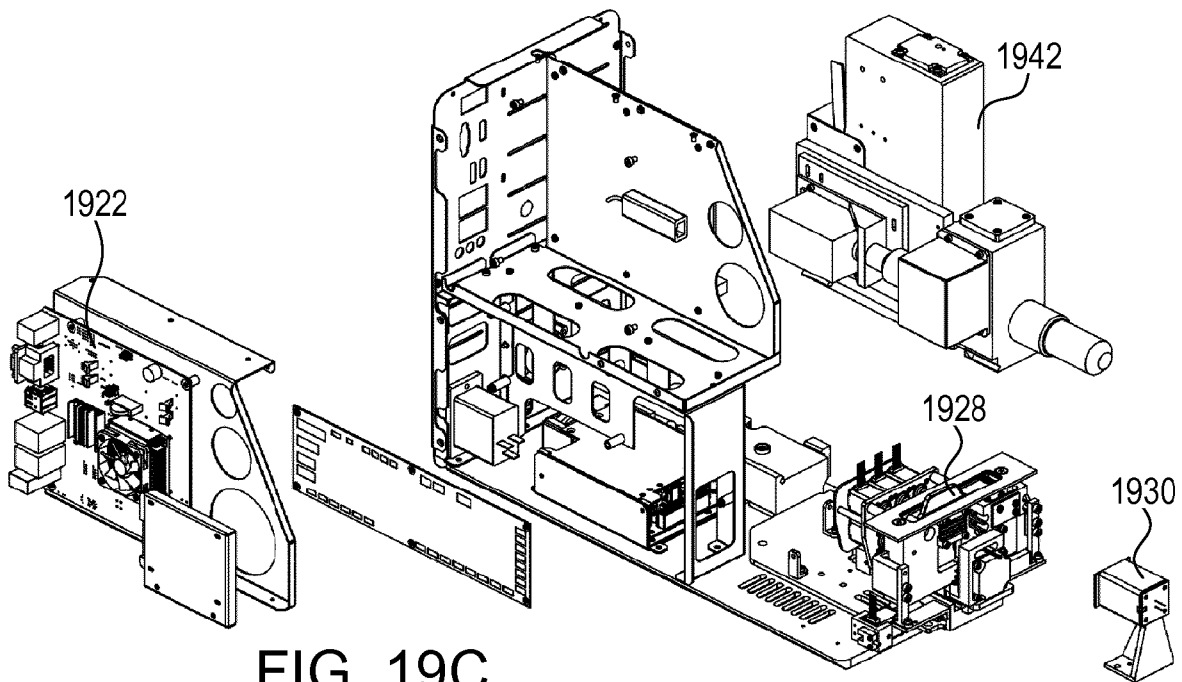
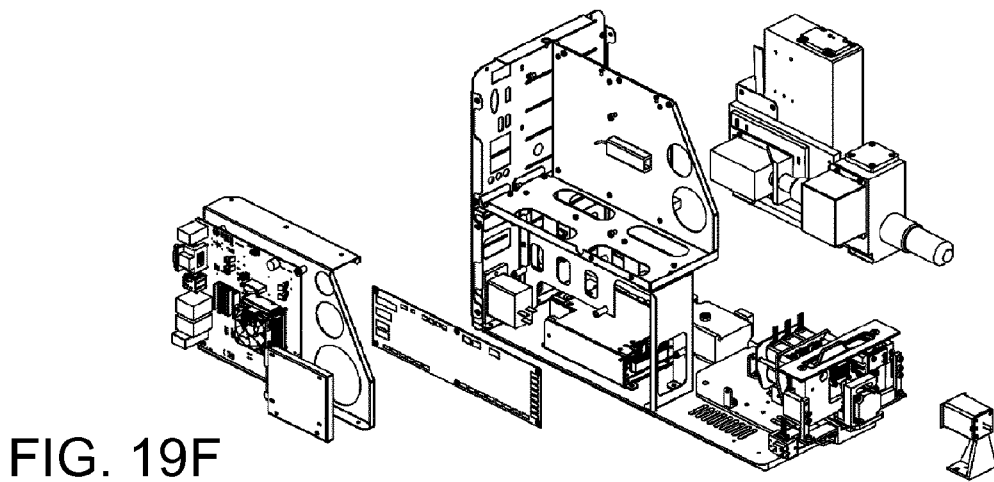
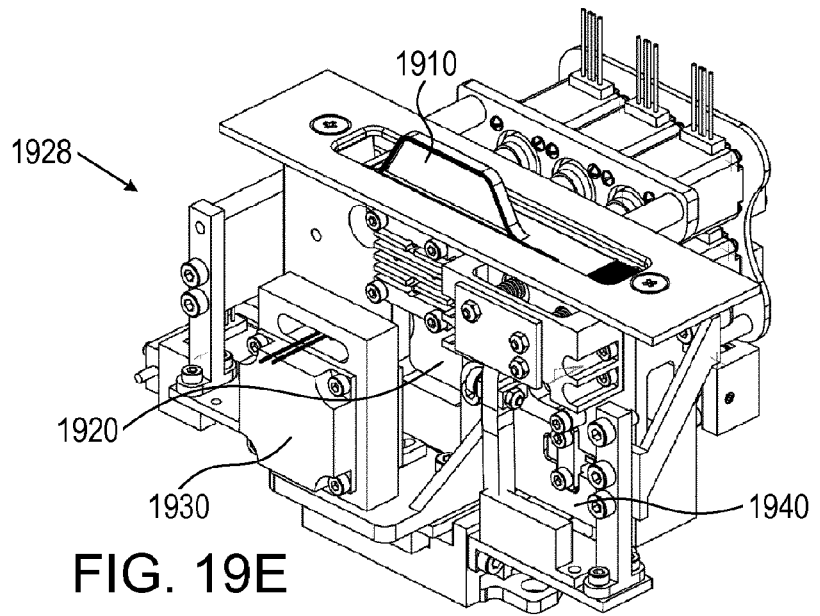
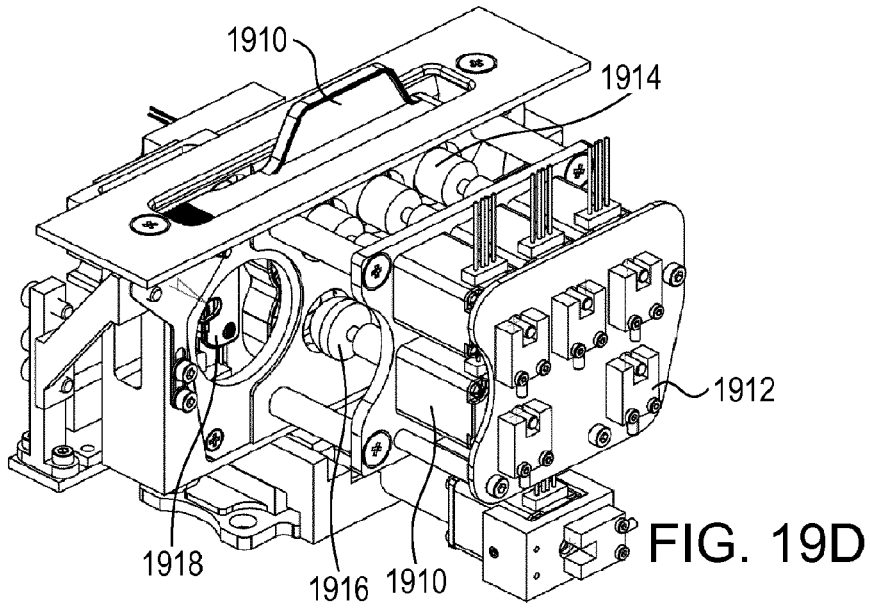

FIG. 19C



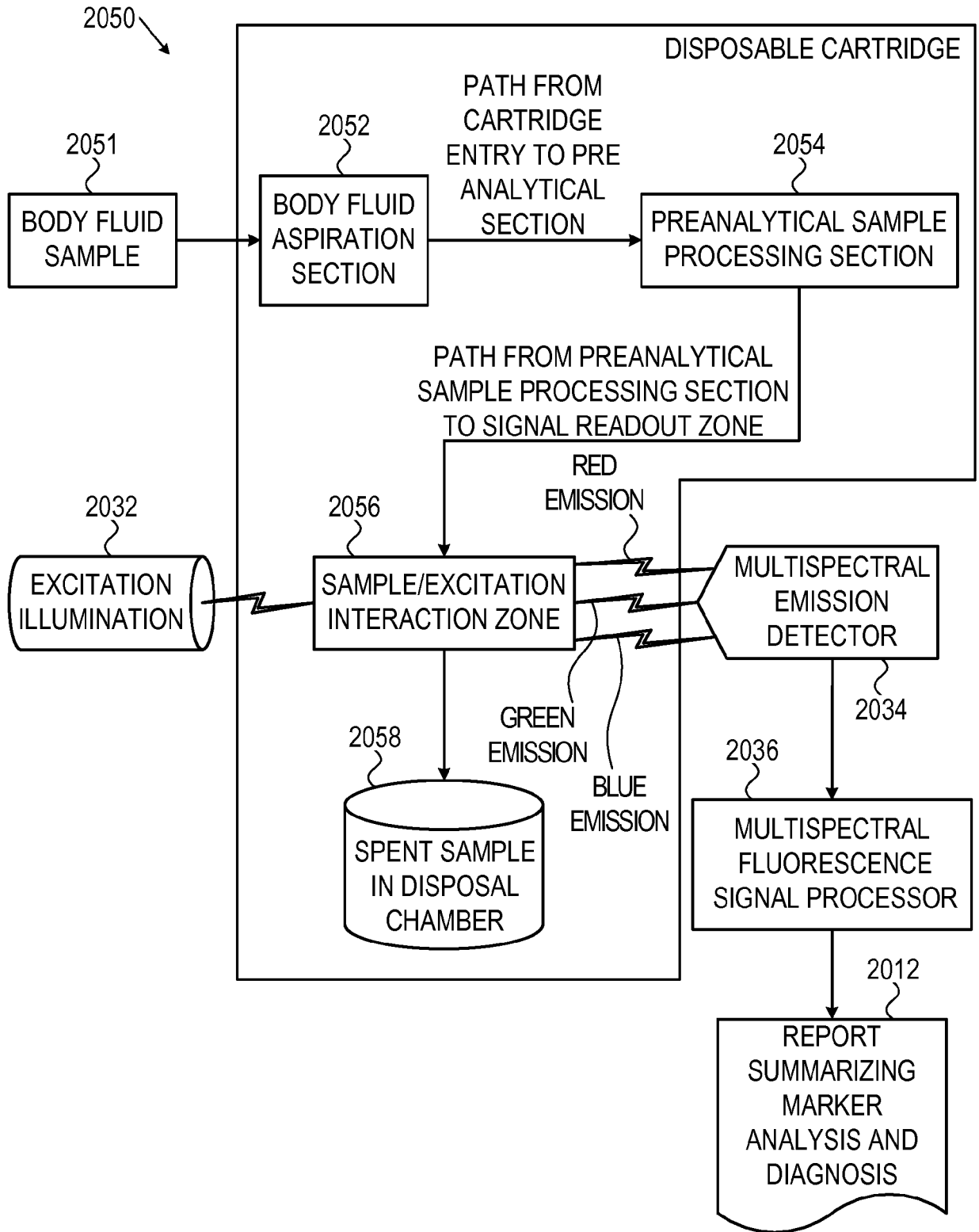

FIG. 20

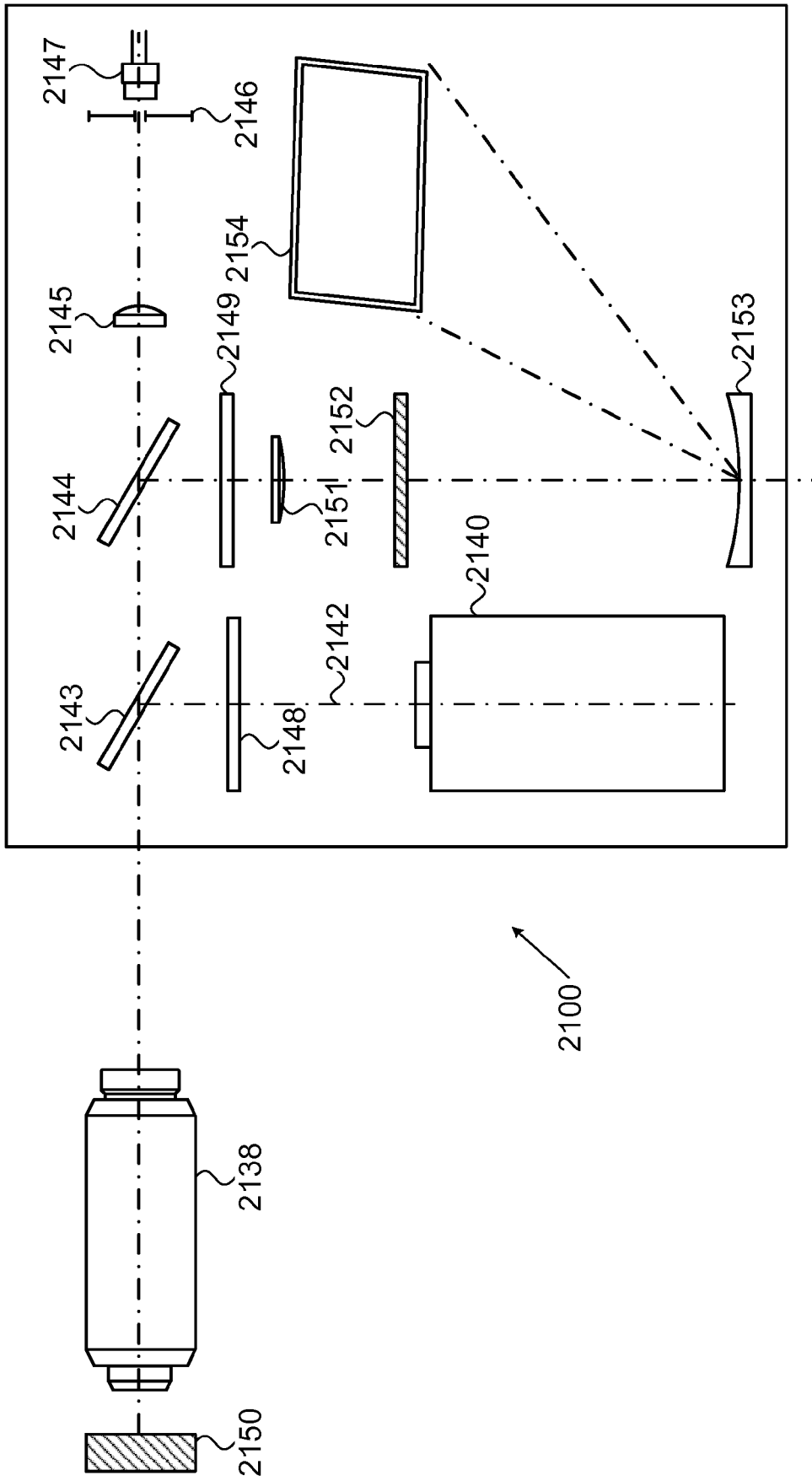

FIG. 21A

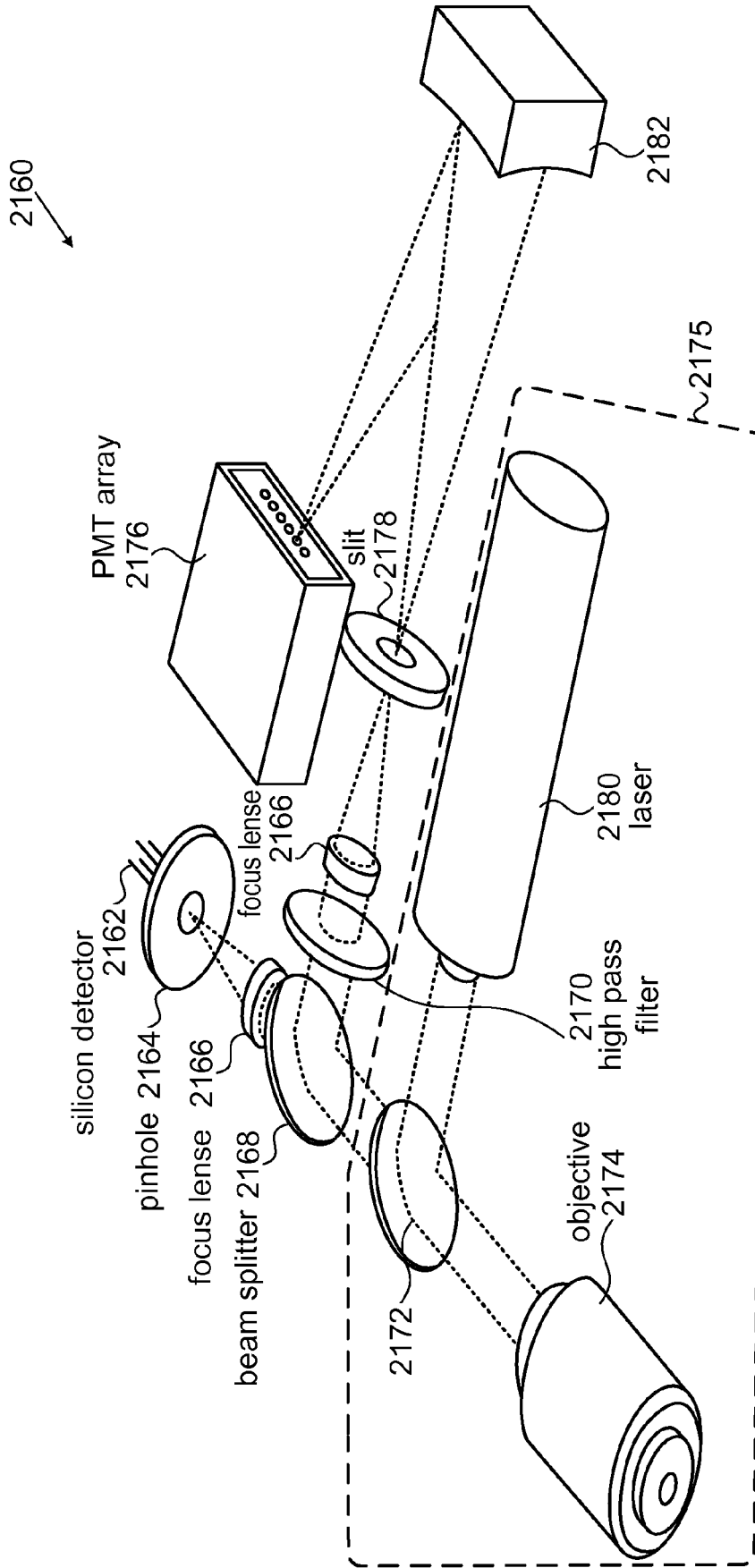
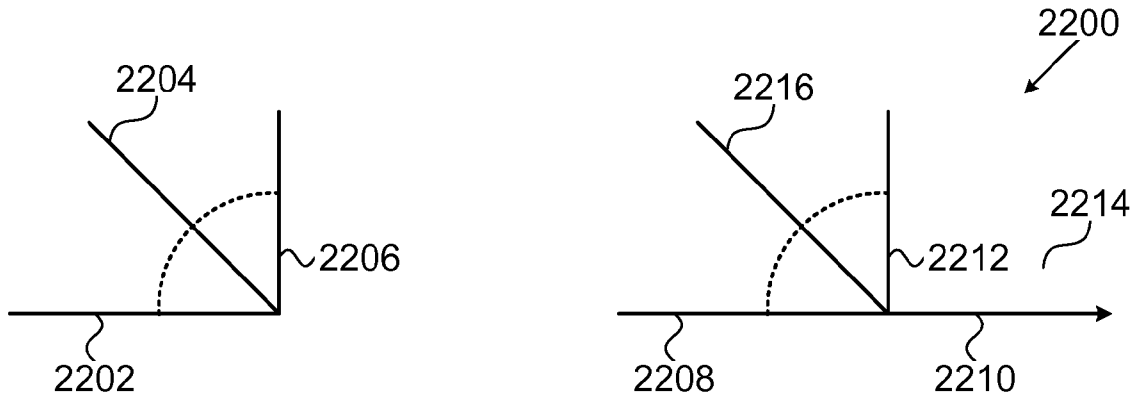

FIG. 21B



The setup for RGB lasers

FIG. 22A

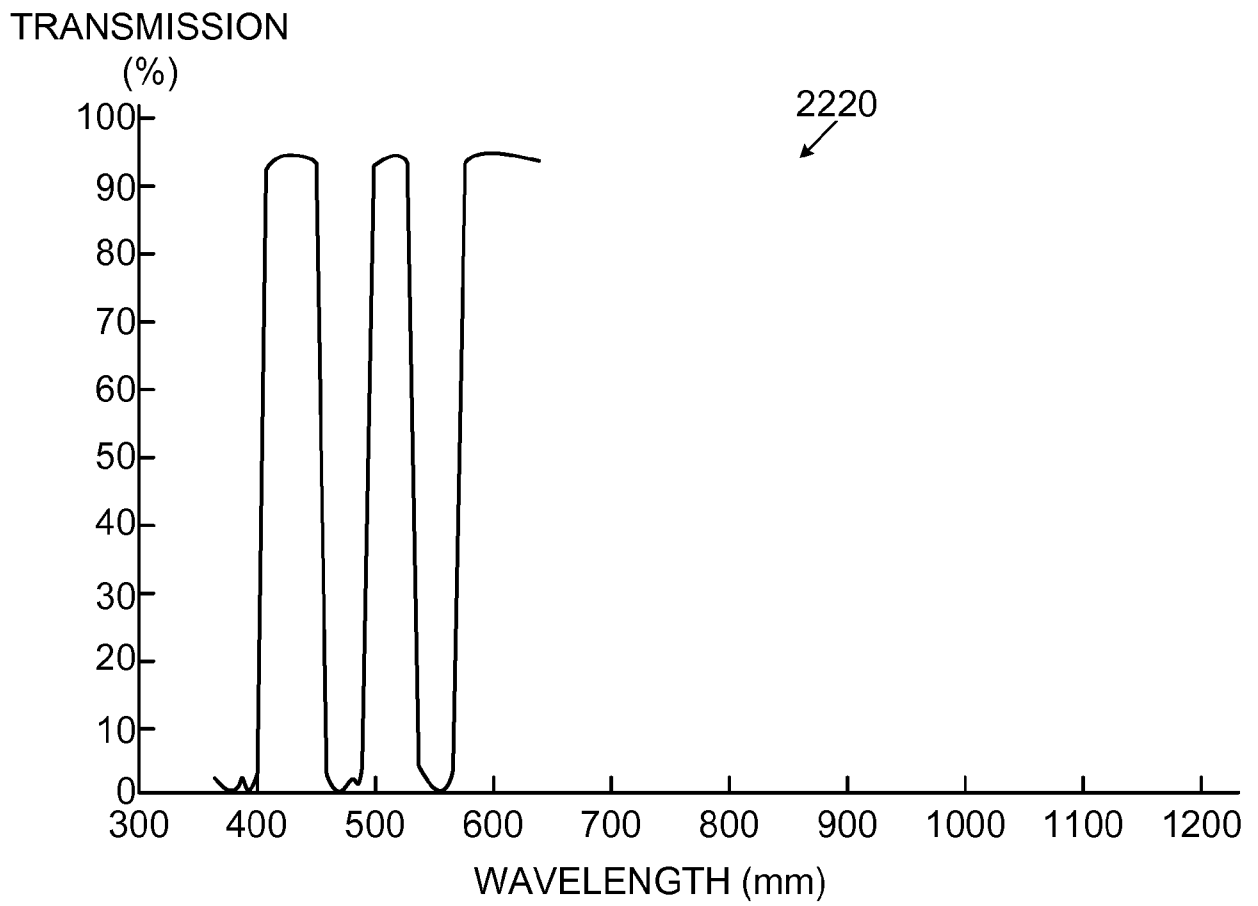

FIG. 22B

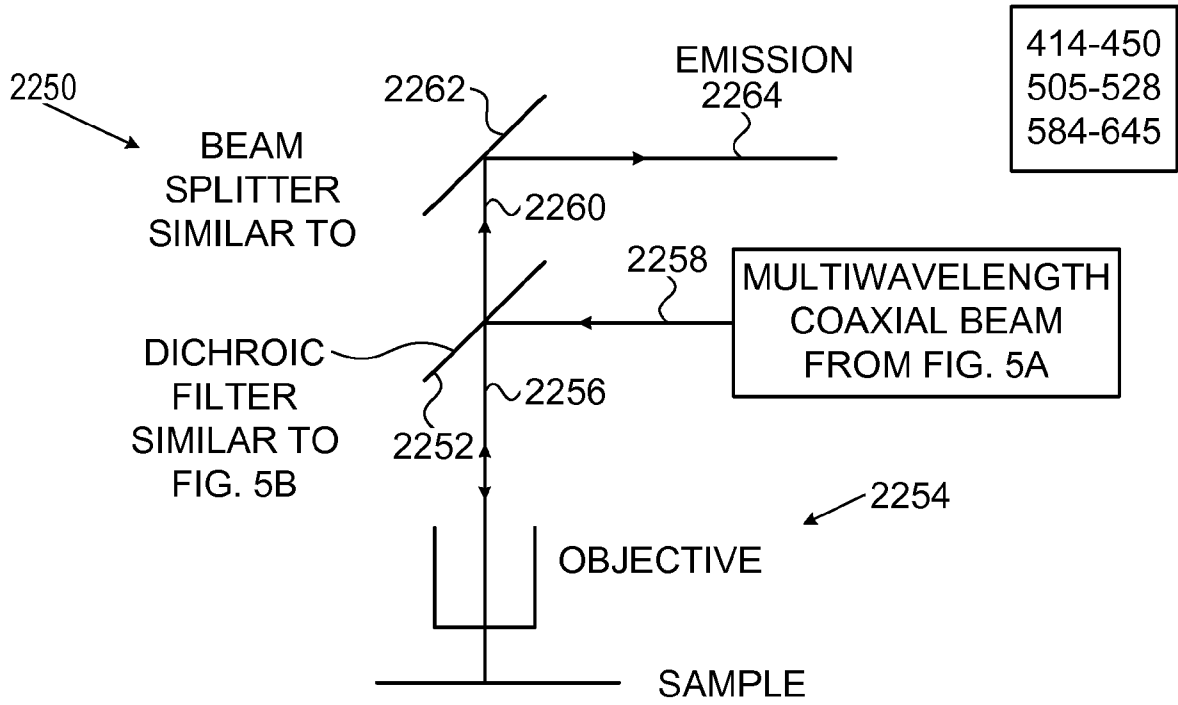

FIG. 22C

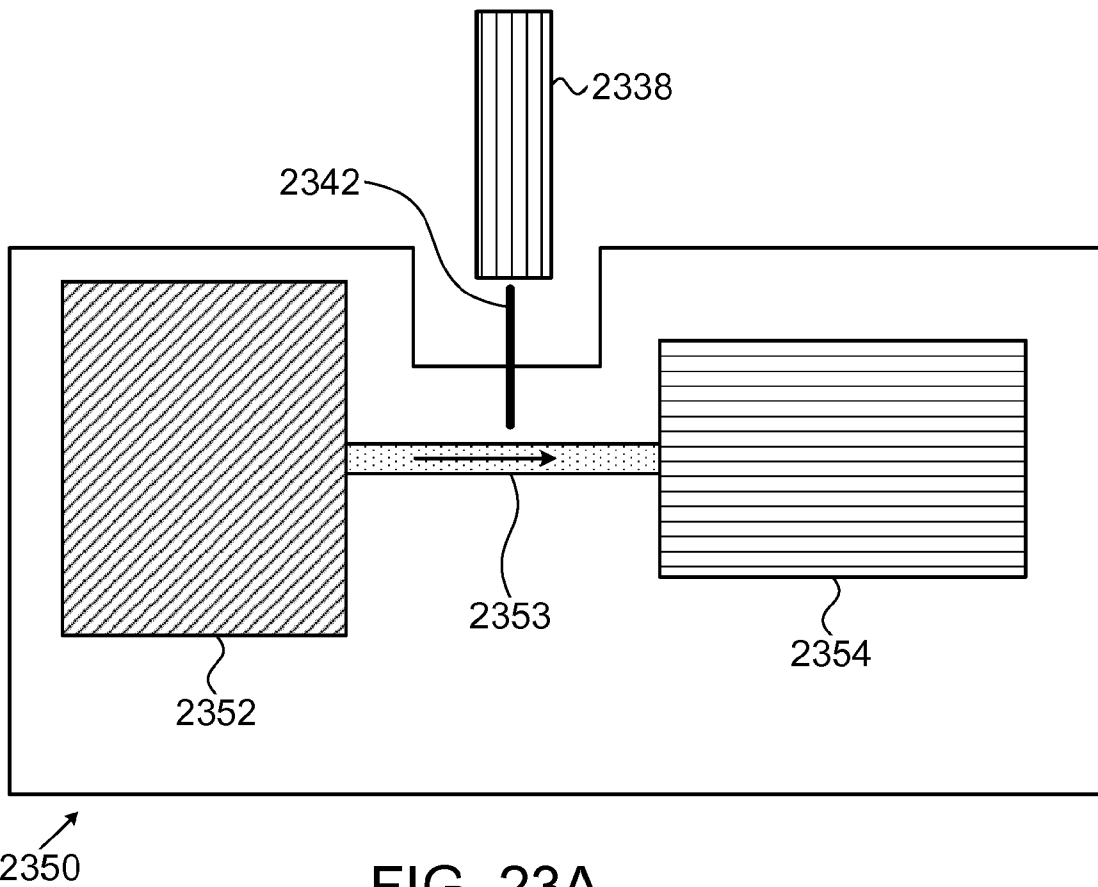

FIG. 23A

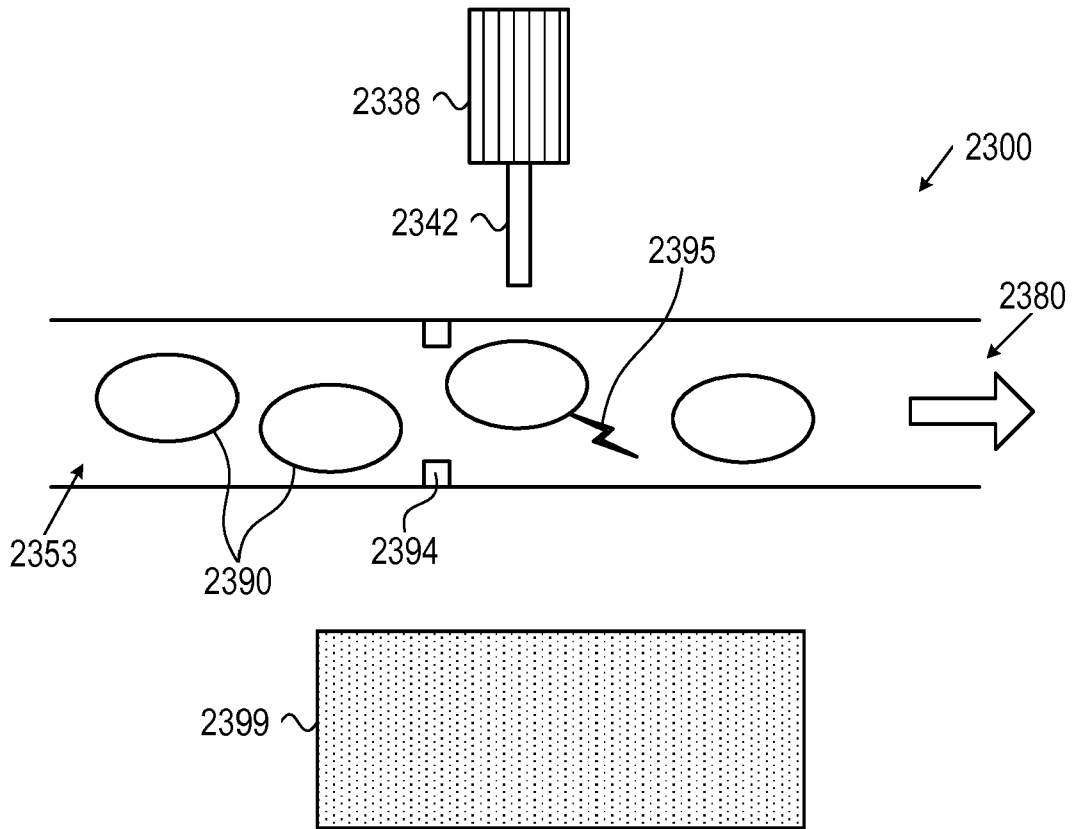

FIG. 23B

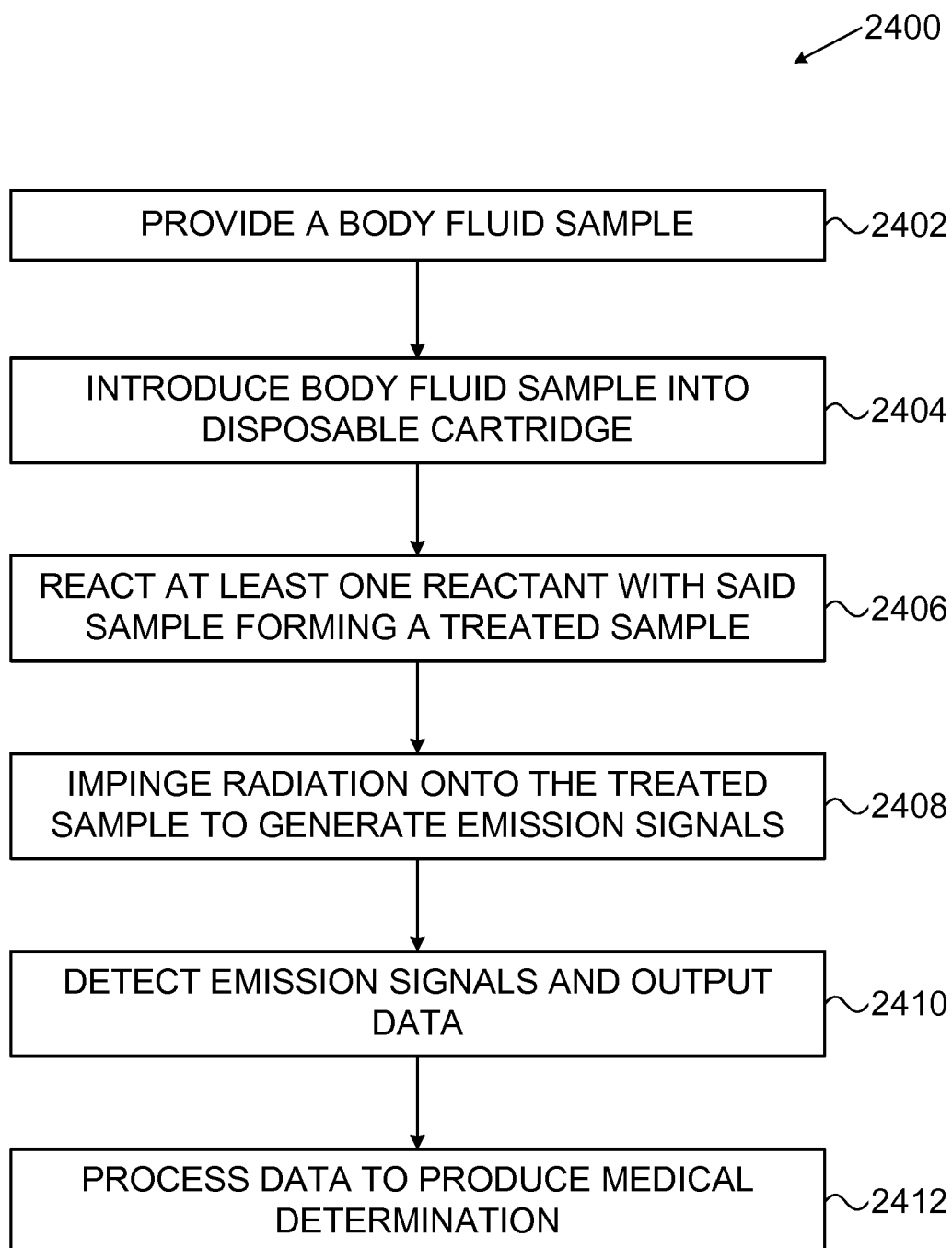

FIG. 24

- Objective: Nikon 20x/0.5NA
- Peristaltic pump = 20
- Attenuator = 2

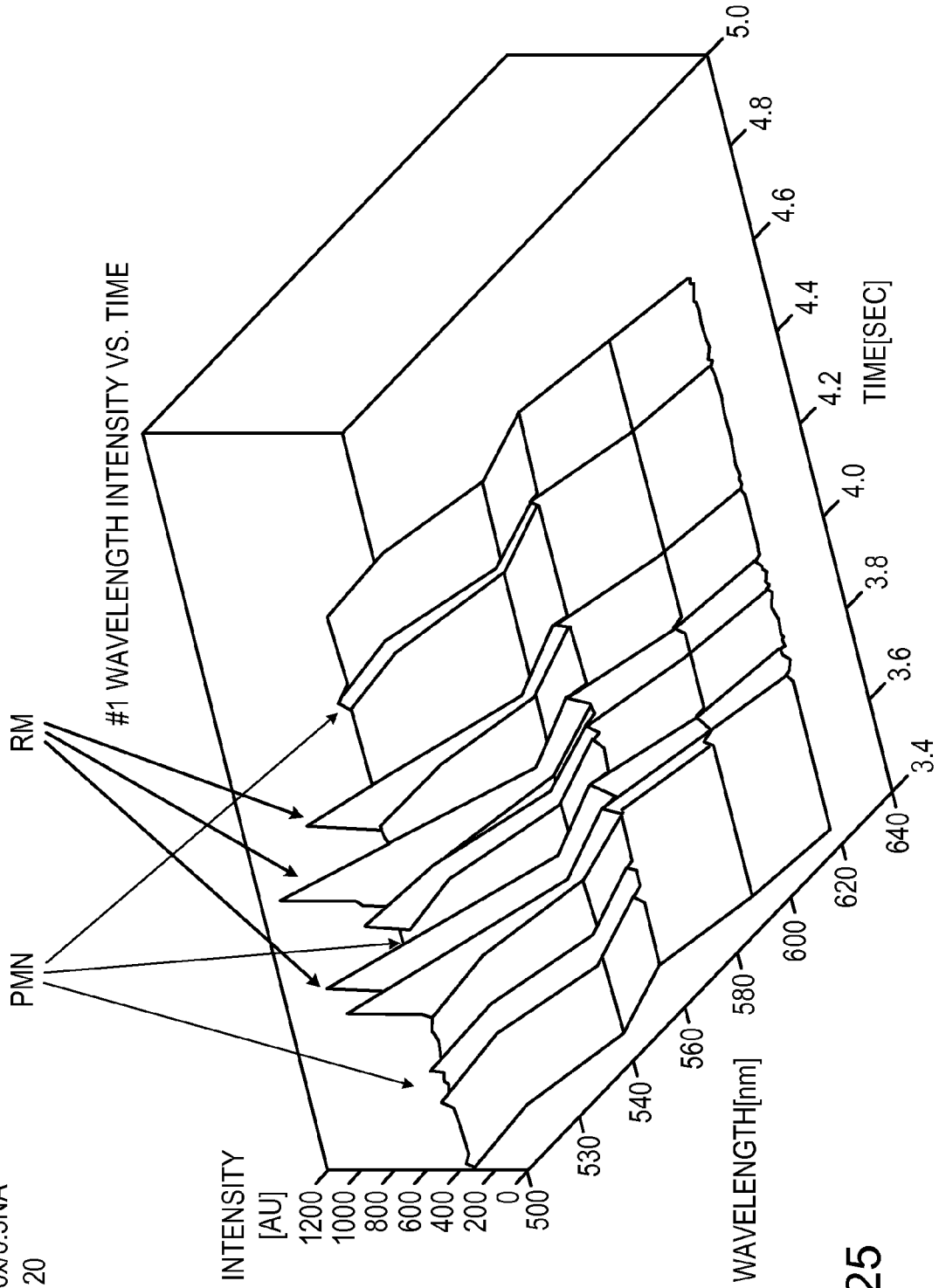
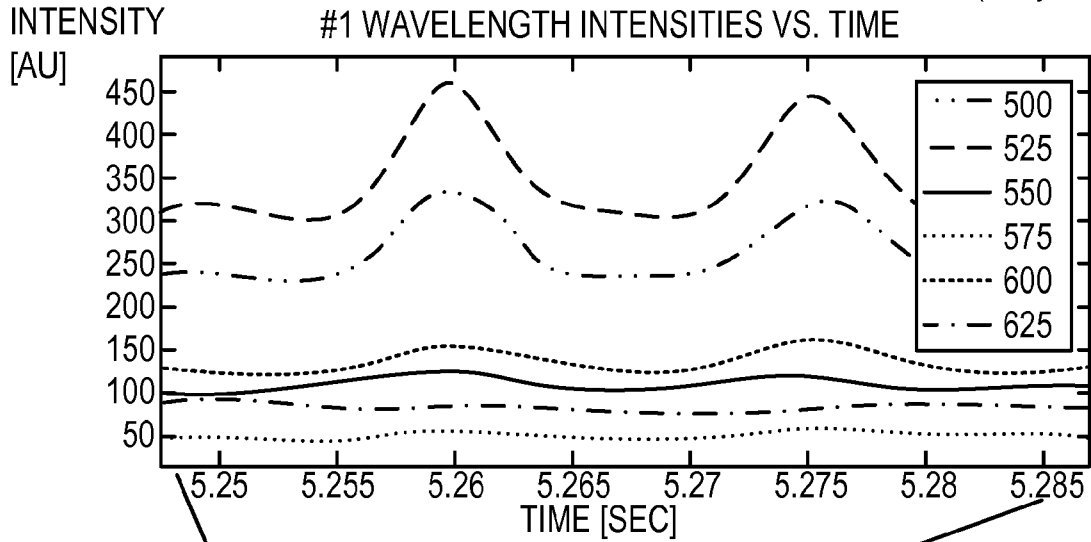

FIG. 25

**FIG. 26A**  
(Grayscale)

**PMN PULSE SHAPE:**  
INTENSITY



**PMN SIGNALS:**  
INTENSITY

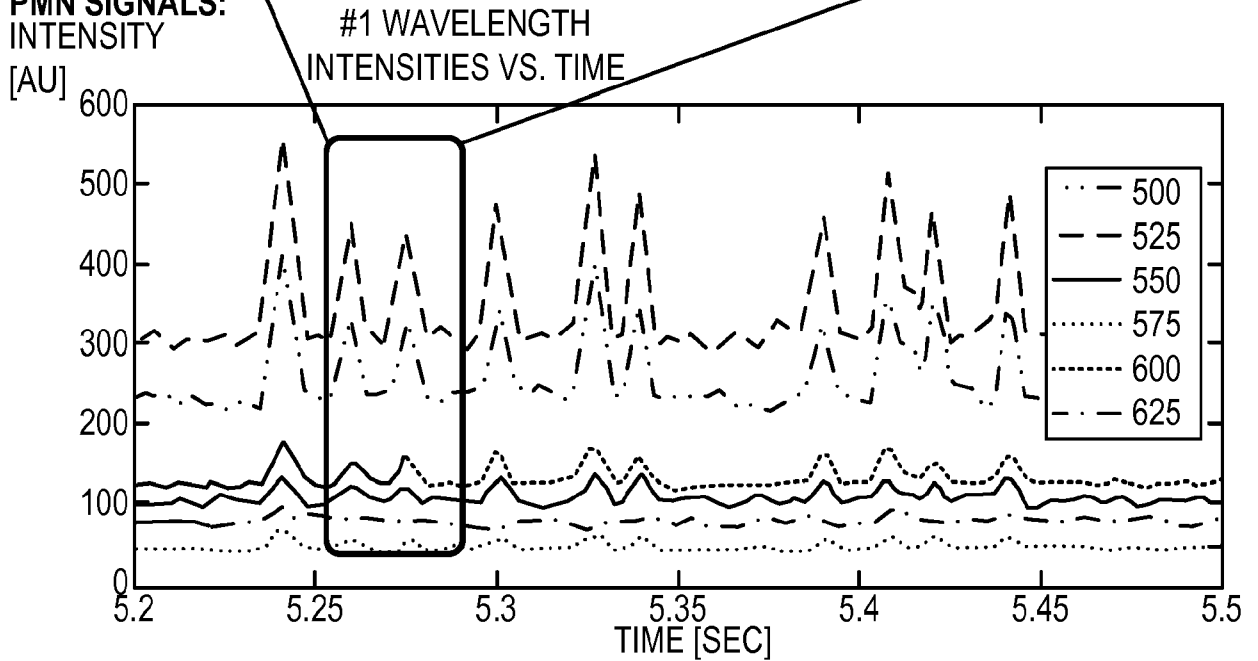

**FIG. 26B**

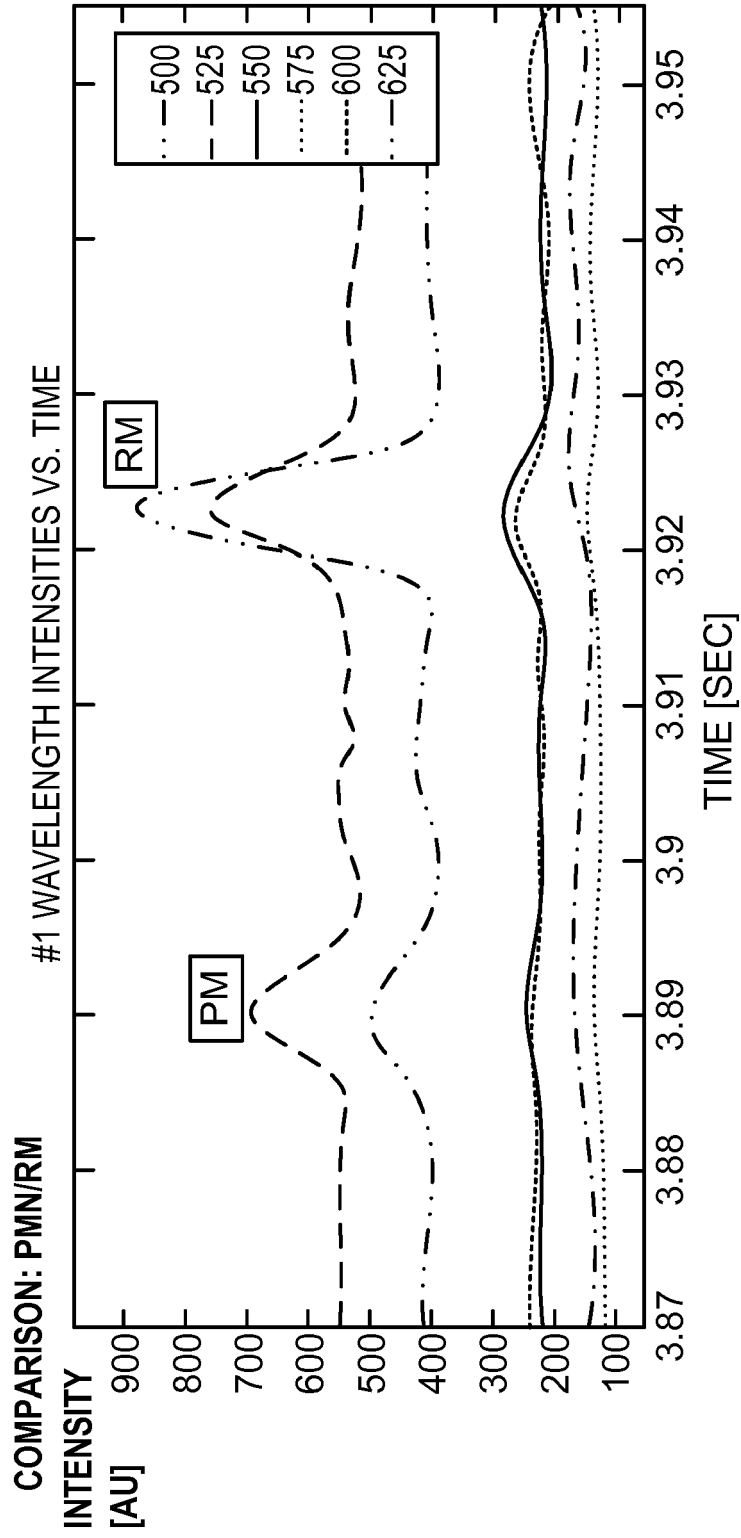

FIG. 26C



EUROPEAN SEARCH REPORT

Application Number  
EP 18 21 5979

5

10

15

20

25

30

35

40

45

50

55

DOCUMENTS CONSIDERED TO BE RELEVANT			
Category	Citation of document with indication, where appropriate, of relevant passages	Relevant to claim	CLASSIFICATION OF THE APPLICATION (IPC)
Y	WO 2011/094577 A2 (MICRONICS INC [US]; BATTRELL C FREDERICK [US]; SPRAGUE ISAAC [US]; BRA) 4 August 2011 (2011-08-04) * abstract * * page 4, line 29 - page 7, line 14 * * page 8, line 28 - page 9, line 20 * -----	1-15	INV. G01N33/53 G01N21/75 C12M1/34 G01N33/558 B01L3/00 G01N21/64 G01N33/569 G01N21/03
A	US 2003/233827 A1 (KUO YUAN-FONG [TW] ET AL) 25 December 2003 (2003-12-25) * abstract; figure 1 * * paragraphs [0009] - [0011], [0023], [0029] - [0032] * -----	1-15	
A	WO 2012/120506 A2 (PIXCELL MEDICAL TECHNOLOGIES LTD [IL]; BRANSKY AVISHAY [IL]; SHLOMO LI) 13 September 2012 (2012-09-13) * abstract * * page 5, lines 18-20 * * * -----	1-15	
Y	WO 2006/055816 A2 (TRILLIUM DIAGNOSTICS LLC; DAVIS BRUCE H [US]; BAGWELL C BRUCE [US]; HU) 26 May 2006 (2006-05-26) * pages 1-5 * -----	4,9,12,15	TECHNICAL FIELDS SEARCHED (IPC) G01N B01L
Y	WO 2011/128893 A2 (LEUKODX LTD [IL]; KASDAN HARVEY LEE [IL]; RAJUAN MENASHE [IL]; BRODER) 20 October 2011 (2011-10-20) * the whole document * -----	4,9,12,15	
A	US 2012/071342 A1 (LOCHHEAD MICHAEL J [US] ET AL) 22 March 2012 (2012-03-22) * abstract * -----	1-15	
		-/--	
1 The present search report has been drawn up for all claims			
Place of search Munich		Date of completion of the search 24 May 2019	Examiner Meacher, David
CATEGORY OF CITED DOCUMENTS X : particularly relevant if taken alone Y : particularly relevant if combined with another document of the same category A : technological background O : non-written disclosure P : intermediate document		T : theory or principle underlying the invention E : earlier patent document, but published on, or after the filing date D : document cited in the application L : document cited for other reasons ----- & : member of the same patent family, corresponding document	

EPO FORM 1503 03.02 (P04001)



EUROPEAN SEARCH REPORT

Application Number  
EP 18 21 5979

5

10

15

20

25

30

35

40

45

50

55

DOCUMENTS CONSIDERED TO BE RELEVANT			
Category	Citation of document with indication, where appropriate, of relevant passages	Relevant to claim	CLASSIFICATION OF THE APPLICATION (IPC)
Y	WO 2007/076549 A2 (HONEYWELL INT INC [US]; GU YUANDONG [US]; PADMANABHAN ARAVIND [US]) 5 July 2007 (2007-07-05) * page 31 *	10	
Y	US 6 852 284 B1 (HOLL MARK R [US] ET AL) 8 February 2005 (2005-02-08) * abstract; figure 9 *	1-15	
The present search report has been drawn up for all claims			TECHNICAL FIELDS SEARCHED (IPC)
Place of search Munich		Date of completion of the search 24 May 2019	Examiner Meacher, David
CATEGORY OF CITED DOCUMENTS X : particularly relevant if taken alone Y : particularly relevant if combined with another document of the same category A : technological background O : non-written disclosure P : intermediate document		T : theory or principle underlying the invention E : earlier patent document, but published on, or after the filing date D : document cited in the application L : document cited for other reasons ..... & : member of the same patent family, corresponding document	

1  
EPO FORM 1503 03 02 (P04C01)

ANNEX TO THE EUROPEAN SEARCH REPORT  
ON EUROPEAN PATENT APPLICATION NO.

EP 18 21 5979

5 This annex lists the patent family members relating to the patent documents cited in the above-mentioned European search report.  
The members are as contained in the European Patent Office EDP file on  
The European Patent Office is in no way liable for these particulars which are merely given for the purpose of information.

24-05-2019

Patent document cited in search report	Publication date	Patent family member(s)	Publication date
WO 2011094577 A2	04-08-2011	CA 2786569 A1	04-08-2011
		CN 102740976 A	17-10-2012
		EP 2528687 A2	05-12-2012
		JP 5791634 B2	07-10-2015
		JP 2013518289 A	20-05-2013
		KR 20130033345 A	03-04-2013
		US 2013130262 A1	23-05-2013
		US 2016193603 A1	07-07-2016
		WO 2011094577 A2	04-08-2011
		-----	-----
US 2003233827 A1	25-12-2003	NONE	
-----	-----	-----	-----
WO 2012120506 A2	13-09-2012	CN 103608110 A	26-02-2014
		CN 107367406 A	21-11-2017
		EP 2683483 A2	15-01-2014
		JP 6116490 B2	19-04-2017
		JP 6310980 B2	11-04-2018
		JP 2014511494 A	15-05-2014
		JP 2017049256 A	09-03-2017
		KR 20140025380 A	04-03-2014
		RU 2013145080 A	20-04-2015
		US 2014033809 A1	06-02-2014
		US 2017146434 A1	25-05-2017
		US 2018328821 A1	15-11-2018
		WO 2012120506 A2	13-09-2012
-----	-----	-----	-----
WO 2006055816 A2	26-05-2006	EP 1836557 A2	26-09-2007
		JP 5047803 B2	10-10-2012
		JP 2008520247 A	19-06-2008
		US 2009117605 A1	07-05-2009
		US 2012084013 A1	05-04-2012
		US 2013230867 A1	05-09-2013
		WO 2006055816 A2	26-05-2006
		-----	-----
WO 2011128893 A2	20-10-2011	CN 102859365 A	02-01-2013
		CN 105424665 A	23-03-2016
		CN 105572019 A	11-05-2016
		EP 2558870 A2	20-02-2013
		EP 3239717 A1	01-11-2017
		US 2013102087 A1	25-04-2013
		WO 2011128893 A2	20-10-2011
		-----	-----
US 2012071342 A1	22-03-2012	EP 2616797 A1	24-07-2013
		TW 201217783 A	01-05-2012
		US 2012071342 A1	22-03-2012
		WO 2012037369 A1	22-03-2012

EPC FORM P/VI/59

For more details about this annex : see Official Journal of the European Patent Office, No. 12/82

55

ANNEX TO THE EUROPEAN SEARCH REPORT  
ON EUROPEAN PATENT APPLICATION NO.

EP 18 21 5979

5 This annex lists the patent family members relating to the patent documents cited in the above-mentioned European search report.  
The members are as contained in the European Patent Office EDP file on  
The European Patent Office is in no way liable for these particulars which are merely given for the purpose of information.

24-05-2019

Patent document cited in search report	Publication date	Patent family member(s)	Publication date	
WO 2007076549	A2	05-07-2007	CN 101389947 A	18-03-2009
			EP 1966588 A2	10-09-2008
			JP 5431732 B2	05-03-2014
			JP 2009522556 A	11-06-2009
			US 2007190525 A1	16-08-2007
			WO 2007076549 A2	05-07-2007
US 6852284	B1	08-02-2005	AU 3771599 A	06-12-1999
			CA 2320296 A1	25-11-1999
			EP 1046032 A1	25-10-2000
			US 6537501 B1	25-03-2003
			US 6576194 B1	10-06-2003
			US 6712925 B1	30-03-2004
			US 6852284 B1	08-02-2005
			US 2003096430 A1	22-05-2003
			US 2003152487 A1	14-08-2003
			US 2006127275 A1	15-06-2006
			WO 9960397 A1	25-11-1999

EPC FORM P0159

For more details about this annex : see Official Journal of the European Patent Office, No. 12/82

## REFERENCES CITED IN THE DESCRIPTION

This list of references cited by the applicant is for the reader's convenience only. It does not form part of the European patent document. Even though great care has been taken in compiling the references, errors or omissions cannot be excluded and the EPO disclaims all liability in this regard.

## Patent documents cited in the description

- US 61737854 B, Kasdan [0001]
- US 61737856 B, Kasdan [0001]
- US 13716246 B [0001]
- US 8116984 B, Davis [0006] [0195] [0231] [0254] [0262] [0400]
- US 2006215155 A [0007]
- WO 12019599 A [0008]
- US 2012187117 A [0009]
- WO 2011128893 A, Kasdan [0183] [0208] [0260] [0264] [0265] [0313] [0326]
- US 669191S1 D [0184]
- US 20120266986 A1 [0184]
- EP 1846159 A2 [0184]
- US 2012275972 A [0184]
- WO 11094577 A [0184]
- US 2007292941 A [0184]
- EP 1263533 B1 [0184]
- US 4500509 A [0406]
- US 3241432 A [0415]
- WO IL2013000092 A [0416]
- WO 2014097286 A [0416]

## Non-patent literature cited in the description

- **DAVIS ; BRUCE H. et al.** Neutrophil CD64 is an improved indicator of infection or sepsis in emergency department patients. *Archives of pathology & laboratory medicine*, 2006, vol. 130.5, 654-661 [0400] [0415]
- **HOFFMANN ; JOHANNES JML.** Neutrophil CD64 as a sepsis biomarker. *Biochemia Medica*, 2011, vol. 21.3, 282-290 [0400]
- **CROWE ; SUZANNE et al.** Monitoring of human immunodeficiency virus infection in resource-constrained countries. *Clinical infectious diseases*, 2003, vol. 37 (1), S25-S35 [0401]
- **NIELSEN ; JULIE S. ; KELLY M. MCNAGNY.** Novel functions of the CD34 family. *Journal of Cell Science*, 2008, vol. 121.22, 3683-3692 [0402]
- **RAWSTRON, A. C. et al.** International standardized approach for flow cytometric residual disease monitoring in chronic lymphocytic leukaemia. *Leukemia*, 2007, vol. 21.5, 956-964 [0403]
- **RAWSTRON ; ANDY C. et al.** Report of the European Myeloma Network on multiparametric flow cytometry in multiple myeloma and related disorders. *haematologica*, 2008, vol. 93.3, 431-438 [0403]
- **BRÜGGEMANN, M. et al.** Standardized MRD quantification in European ALL trials: proceedings of the Second International Symposium on MRD assessment in Kiel, Germany. *Leukemia*, 18 September 2008, vol. 24.3, 521-535 [0403]
- **RAWSTRON, A. C. et al.** Improving efficiency and sensitivity: European Research Initiative in CLL (ERIC) update on the international harmonised approach for flow cytometric residual disease monitoring in CLL. *Leukemia*, 2012, vol. 27.1, 142-149 [0403]
- Flow cytometric MRD detection in selected mature B-cell malignancies. **BÖTTCHER ; SEBASTIAN ; MATTHIAS RITGEN ; MICHAEL KNEBA.** Lymphoma. Humana Press, 2013, 149-174 [0403]
- **STEHLÍKOVÁ, O. et al.** Detecting minimal residual disease in patients with chronic lymphocytic leukemia using 8-color flow cytometry protocol in routine hematological practice. *International journal of laboratory hematology*, 2013 [0403]
- Postgraduate seminar of the on Laboratory Techniques. **MULLIER ; FRANÇOIS ; BERNARD CHATELAIN.** Immunophenotyping by flow cytometry. Haematological Society, 2013 [0403]
- **WIESTNER ; ADRIAN et al.** ZAP-70 expression identifies a chronic lymphocytic leukemia subtype with unmutated immunoglobulin genes, inferior clinical outcome, and distinct gene expression profile. *Blood*, 2003, vol. 101.12, 4944-4951 [0403]
- **BLUE ; MARIE-LUISE et al.** Coexpression of T4 and T8 on peripheral blood T cells demonstrated by two-color fluorescence flow cytometry. *The Journal of immunology*, 1985, vol. 134.4, 2281-2286 [0404]
- **LANIER ; LEWIS L. ; MICHAEL R. LOKEN.** Human lymphocyte subpopulations identified by using three-color immunofluorescence and flow cytometry analysis: correlation of Leu-2, Leu-3, Leu-7, Leu-8, and Leu-11 cell surface antigen expression. *The Journal of Immunology*, 1984, vol. 132.1, 151-156 [0404]
- **MERCOLINO ; THOMAS J. et al.** Immunologic differentiation of absolute lymphocyte count with an integrated flow cytometric system: a new concept for absolute T cell subset determinations. *Cytometry*, 1995, vol. 22.1, 48-59 [0404]

- **COMANS-BITTER ; W. MARIEKE et al.** Immunophenotyping of blood lymphocytes in childhood. Reference values for lymphocyte subpopulations. *The Journal of pediatrics*, 1997, vol. 130.3, 388-393 [0404]
- **INGHIRAMI, G. et al.** Flow cytometric and immunohistochemical characterization of the gamma/delta T-lymphocyte population in normal human lymphoid tissue and peripheral blood. *The American journal of pathology*, 1990, vol. 136.2, 357 [0404]
- **CHENG ; ANN-JOY et al.** Oral cancer plasma tumor marker identified with bead-based affinity-fractionated proteomic technology. *Clinical Chemistry*, 2005, vol. 51.12, 2236-2244 [0409]
- **BONINI ; PIERANGELO et al.** Errors in laboratory medicine. *Clinical Chemistry*, 2002, vol. 48.5, 691-698 [0410]
- **LEGRAND, C. et al.** Lactate dehydrogenase (LDH) activity of the number of dead cells in the medium of cultured eukaryotic cells as marker. *Journal of biotechnology*, 1992, vol. 25.3, 231-243 [0410]
- **CANNING, D. M. ; R. G. HUNTSMAN.** An assessment of Sickledex as an alternative to the sickling test. *Journal of Clinical Pathology*, 1970, vol. 23.8, 735-737 [0410]
- **BOSSY-WETZEL ; ELLA ; DOUGLAS R. GREEN.** Detection of apoptosis by annexin V labeling. *Methods in enzymology*, 2000, vol. 322, 15-18 [0411]
- **ASSICOT ; MARCEL et al.** High serum procalcitonin concentrations in patients with sepsis and infection. *The Lancet*, 1993, vol. 341 (8844), 515-518 [0415]
- **AULESA, C. et al.** Validation of the Coulter LH 750 in a hospital reference laboratory. *Laboratory Hematology*, 2003, vol. 9.1, 15-28 [0415]
- **HAWKINS ; ROBERT C.** Laboratory turnaround time. *The Clinical Biochemist Reviews*, 2007, vol. 28.4, 179 [0415]
- **AULT ; KENNETH A.** Flow cytometric measurement of platelet function and reticulated platelets. *Annals of the New York Academy of Sciences*, 1993, vol. 677.1, 293-308 [0415]
- **BLAJCHMAN ; MORRIS A. et al.** Bacterial detection of platelets: current problems and possible resolutions. *Transfusion medicine reviews*, 2005, vol. 19.4, 259-272 [0415]
- **BODENSTEINER ; DAVID C.** A flow cytometric technique to accurately measure post-filtration white blood cell counts. *Transfusion*, 1989, vol. 29.7, 651-653 [0415]
- **CHESON ; BRUCE D. et al.** National Cancer Institute-sponsored Working Group guidelines for chronic lymphocytic leukemia: revised guidelines for diagnosis and treatment. *Blood*, 1996, vol. 87.12, 4990-4997 [0415]
- **CHRIST-CRAIN ; MIRJAM et al.** Effect of procalcitonin-guided treatment on antibiotic use and outcome in lower respiratory tract infections: cluster-randomised, single-blinded intervention trial. *Lancet*, 2004, vol. 363.9409, 600-607 [0415]
- **CRISTOFANILLI ; MASSIMO et al.** Circulating tumor cells, disease progression, and survival in metastatic breast cancer. *New England Journal of Medicine*, 2004, vol. 351.8, 781-791 [0415]
- **DIEYE ; TANDAKHA NDIAYE et al.** Absolute CD4 T-cell counting in resource-poor settings: direct volumetric measurements versus bead-based clinical flow cytometry instruments. *JAIDS Journal of Acquired Immune Deficiency Syndromes*, 2005, vol. 39.1, 32-37 [0415]
- **DIVERS, S. G. et al.** Quantitation of CD62, soluble CD62, and lysosome-associated membrane proteins 1 and 2 for evaluation of the quality of stored platelet concentrates. *Transfusion*, 2003, vol. 35.4, 292-297 [0415]
- **DREXLER ; HANS G. et al.** Diagnostic value of immunological leukemia phenotyping. *Acta haematologica*, 1986, vol. 76.1, 1-8 [0415]
- **DZIEGIEL ; MORTEN HANEFELD ; LEIF KOFOED NIELSEN ; ADELA BERKOWICZ.** Detecting fetomaternal hemorrhage by flow cytometry. *Current opinion in hematology*, 2006, vol. 13.6, 490 [0415]
- **FISCHER ; JOHANNES C. et al.** Reducing costs in flow cytometric counting of residual white blood cells in blood products: utilization of a single platform bead free flow rate calibration method. *Transfusion*, 2011, vol. 51.7, 1431-1438 [0415]
- **FREE, A. H. ; H. M. FREE.** Urinalysis, critical discipline of clinical science. *Critical Reviews in Clinical Laboratory Sciences*, 1972, vol. 3.4, 481-531 [0415]
- **FRENGEN ; JOMAR et al.** Demonstration and minimization of serum interference in flow cytometric two-site immunoassays. *Clinical chemistry*, 1994, vol. 40.3, 420-425 [0415]
- **FRENGEN, J. et al.** Homogeneous immunofluorometric assays of alpha-fetoprotein with macroporous, monosized particles and flow cytometry. *Clinical chemistry*, 1993, vol. 39.10, 2174-2181 [0415]
- **GOSLING ; JAMES P.** A decade of development in immunoassay methodology. *Clinical chemistry*, 1990, vol. 36.8, 1408-1427 [0415]
- **GRAFF ; JOCHEN et al.** Close relationship between the platelet activation marker CD62 and the granular release of platelet-derived growth factor. *Journal of Pharmacology and Experimental Therapeutics*, 2002, vol. 300.3, 952-957 [0415]
- **GUERTI, K. et al.** Performance evaluation of the PENTRA 60C+ automated hematology analyzer and comparison with the ADVIA 2120. *International journal of laboratory hematology*, 2009, vol. 31.2, 132-141 [0415]

- **HERSHMAN, M. J. et al.** Monocyte HLA-DR antigen expression characterizes clinical outcome in the trauma patient. *British Journal of Surgery*, 2005, vol. 77.2, 204-207 [0415]
- **HILFRICH ; RALF ; JALIL HARIRI.** Prognostic relevance of human papillomavirus L1 capsid protein detection within mild and moderate dysplastic lesions of the cervix uteri in combination with p16 biomarker. *Analytical and Quantitative Cytology and Histology*, 2008, vol. 30.2, 78-82 [0415]
- **HILLIER ; SHARON L. et al.** A case-control study of chorioamniotic infection and histologic chorioamnionitis in prematurity. *New England Journal of Medicine*, 1988, vol. 319.15, 972-978 [0415]
- **KIBE ; SAVITRI ; KATE ADAMS ; GAVIN BARLOW.** Diagnostic and prognostic biomarkers of sepsis in critical care. *Journal of Antimicrobial Chemotherapy*, 2011, vol. 66 (2), ii33-ii40 [0415]
- **LAROSA ; STEVEN P. ; STEVEN M. OPAL.** Biomarkers: the future. *Critical care clinics*, 2011, vol. 27.2, 407 [0415]
- **LIU ; N. I. N. G. ; A. H. WU ; SHAN S. WONG.** Improved quantitative Apt test for detecting fetal hemoglobin in bloody stools of newborns. *Clinical chemistry*, 1993, vol. 39.11, 2326-2329 [0415]
- **LOTAN ; YAIR et al.** Bladder cancer screening in a high risk asymptomatic population using a point of care urine based protein tumor marker. *The Journal of urology*, 2009, vol. 182.1, 52-58 [0415]
- **MASSE, M. et al.** Validation of a simple method to count very low white cell concentrations in filtered red cells or platelets. *Transfusion*, 2003, vol. 32.6, 565-571 [0415]
- **MATIC ; GORAN B. et al.** Whole blood analysis of reticulated platelets: improvements of detection and assay stability. *Cytometry*, 1998, vol. 34.5, 229-234 [0415]
- **MCDONALD, C. P. et al.** Use of a solid-phase fluorescent cytometric technique for the detection of bacteria in platelet concentrates. *Transfusion Medicine*, 2005, vol. 15.3, 175-183 [0415]
- **MICHELSON ; ALAN D.** Flow cytometry: a clinical test of platelet function. *Open Access Articles*, 1996, 290 [0415]
- Proteomics in Microfluidic Devices. **MILLER, E.M. ; FREIRE, S.L.S. ; WHEELER, A.R.** In *Encyclopedia of Micro- and Nanofluidics*. Springer: Heidelberg, 2008, vol. 3, 1749-1758 [0415]
- **MORO ; RICARDO et al.** A new broad-spectrum cancer marker. *Vitro Diagnostic Technology*, 2005 [0415]
- **OZANICH JR ; RICHARD M. et al.** Rapid multiplexed flow cytometric assay for botulinum neurotoxin detection using an automated fluidic microbead-trapping flow cell for enhanced sensitivity. *Analytical chemistry*, 2009, vol. 81.14, 5783-5793 [0415]
- **PÁL ; JÓZSEF et al.** Sandwich type ELISA and a fluorescent cytometric microbead assay for quantitative determination of hepatitis B virus X antigen level in human sera. *Journal of immunological methods*, 2005, vol. 306.1, 183-192 [0415]
- **PERRY ; SARA E. et al.** Is low monocyte HLA-DR expression helpful to predict outcome in severe sepsis. *Intensive care medicine*, 2003, vol. 29.8, 1245-1252 [0415]
- **RAMAKUMAR ; SANJAY et al.** Comparison of screening methods in the detection of bladder cancer. *The Journal of urology*, 1999, vol. 161.2, 388-394 [0415]
- **RAWSTRON ; ANDY C. et al.** Quantitation of minimal disease levels in chronic lymphocytic leukemia using a sensitive flow cytometric assay improves the prediction of outcome and can be used to optimize therapy. *Blood*, 2001, vol. 98.1, 29-35 [0415]
- **RODRIGUEZ ; WILLIAM R. et al.** A microchip CD4 counting method for HIV monitoring in resource-poor settings. *PLoS medicine*, 2005, vol. 2.7, e182 [0415]
- **RYLATT, D. B. et al.** An immunoassay for human D dimer using monoclonal antibodies. *Thrombosis research*, 1983, vol. 31.6, 767-778 [0415]
- **SACKS ; DAVID et al.** Guidelines and recommendations for laboratory analysis in the diagnosis and management of diabetes mellitus. *Clinical Chemistry*, 2002, vol. 48.3, 436-472 [0415]
- **SCHWARTZ ; MORTON K. et al.** Chemical and Clinical Evaluation of the Continuous-flow Analyzer" SMAC. *Clinical Chemistry*, 1974, vol. 20.8, 1062-1070 [0415]
- **SEGAL, H. C. et al.** Accuracy of platelet counting haematology analysers in severe thrombocytopenia and potential impact on platelet transfusion. *British Journal of Haematology*, 2005, vol. 128.4, 520-525 [0415]
- **SKEGGS ; LEONARD T. ; HARRY HOCHSTRASSER.** Multiple automatic sequential analysis. *Clinical Chemistry*, 1964, vol. 10.10, 918-936 [0415]
- **STEIN ; PAUL D. et al.** D-dimer for the exclusion of acute venous thrombosis and pulmonary embolism: a systematic review. *Annals of internal medicine*, 2004, vol. 140.8 [0415]
- **SUTHERLAND ; D. ROBERT et al.** The ISHAGE guidelines for CD34+ cell determination by flow cytometry. *Journal of hematotherapy*, 1996, vol. 5.3, 213-226 [0415]
- **WANG ; CHAO et al.** Reticulated platelets predict platelet count recovery following chemotherapy. *Transfusion*, 2002, vol. 42.3, 368-374 [0415]
- **WESTGARD, J. O. et al.** Performance studies on the Technicon" SMAC" analyzer: Precision and comparison of values with methods in routine laboratory service. *Clinical chemistry*, 1976, vol. 22.4, 489-496 [0415]

专利名称(译)	用于确定化学状态的系统和方法		
公开(公告)号	<a href="#">EP3508848A1</a>	公开(公告)日	2019-07-10
申请号	EP2018215979	申请日	2013-12-17
[标]申请(专利权)人(译)	LEUKODX		
申请(专利权)人(译)	LEUKODX LTD		
当前申请(专利权)人(译)	LEUKODX LTD		
[标]发明人	KASDAN HARVEY LEE MEISSONNIER JULIEN ZUTA YOAV ROSEN MICHA HIMMEL YAEL BRODER YEHOASHUA DAVIS BRUCE GOLDMAN BRUCE GIRON BOAZ BOTESAZAN ZION BLASBERG ELIEZER SEMMEL ILAN ASCHKENASY JACQUES		
发明人	KASDAN, HARVEY, LEE MEISSONNIER, JULIEN ZUTA, YOAV ROSEN, MICHA HIMMEL, YAEL BRODER, YEHOASHUA DAVIS, BRUCE GOLDMAN, BRUCE GIRON, BOAZ BOTESAZAN, ZION BLASBERG, ELIEZER SEMMEL, ILAN ASCHKENASY, JACQUES		
IPC分类号	G01N33/53 G01N21/75 C12M1/34 G01N33/558 B01L3/00 G01N21/64 G01N33/569 G01N21/03		
CPC分类号	B01L3/502761 B01L2200/10 G01N15/1459 G01N15/1484 G01N21/03 G01N21/6428 G01N21/75 G01N33/5302 G01N33/56972 G01N2015/1006 G01N2021/0328 G01N2021/6439 G01N2021/6482 G01N2035/00158 G01N2333/70535 B01L3/502 B01L3/5027 B01L3/502715 B01L3/50273 B01L2200 /025 B01L2300/041 B01L2300/0654 B01L2300/0816 B01L2300/0867 B01L2300/0877 B01L2300/0883 B01L2300/123 B01L2300/18 B01L2400/0406 B01L2400/0481 B01L2400/0487 G01N33/5091 G01N33 /54386 G01N33/569 G01N33/582 G01N33/68 G01N33/6872 G01N2333/70596 G01N2800/26		
优先权	61/737854 2012-12-17 US 61/737856 2012-12-17 US 13/716246 2012-12-17 US PCT/IL2013/000092 2013-12-17 WO		
外部链接	<a href="#">Espacenet</a>		

摘要(译)

一种用于进行测定以确定化学状态的测定的独立系统，该系统包括用于在其中进行测定的固定盒，至少一种适于与样品反应的试剂；至少一种报告官功能适于报告所述至少一种试剂与所述样品的反应以报告所述测定结果，其中所述至少一种试剂，所述样品和所述至少一种报道官功能包含在所述盒内。

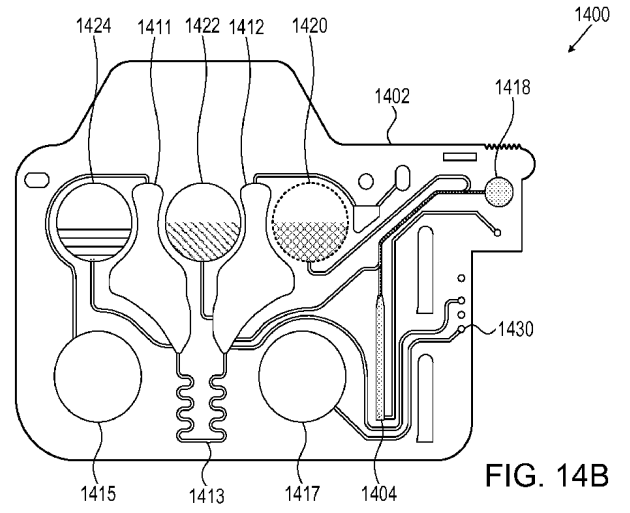

FIG. 14B