



(12) **EUROPEAN PATENT APPLICATION**

(43) Date of publication: **23.07.2003 Bulletin 2003/30** (51) Int Cl.⁷: **G01N 33/92, G01N 33/558, G01N 33/543**

(21) Application number: **02004339.4**

(22) Date of filing: **01.03.2002**

<p>(84) Designated Contracting States: AT BE CH CY DE DK ES FI FR GB GR IE IT LI LU MC NL PT SE TR Designated Extension States: AL LT LV MK RO SI</p> <p>(30) Priority: 18.01.2002 US 349926 P</p> <p>(71) Applicant: CHOLESTECH CORPORATION Hayward, CA 94545-3808 (US)</p> <p>(72) Inventors: <ul style="list-style-type: none"> • Jones, Ronald M. Mountain View, CA 94040 (US) </p>	<ul style="list-style-type: none"> • Worthy, Thomas E. Walnut Creek, CA 94598 (US) • Nugent, Antony Fremont, CA 94555 (US) <p>(74) Representative: Hess, Peter K., Dipl.-Phys. Patent- und Rechtsanwälte Bardehle . Pagenberg . Dost . Altenberg . Geissler Postfach 86 06 20 81633 München (DE)</p>
---	---

(54) **High-density lipoprotein assay device and method**

(57) An assay device and method for measuring the concentration of HDL-associated cholesterol in a blood-fluid sample are described. The device allows multiple assays to be run simultaneously on a controlled amount of a single sample, while minimizing the risk of sample contamination by precipitating reagents.

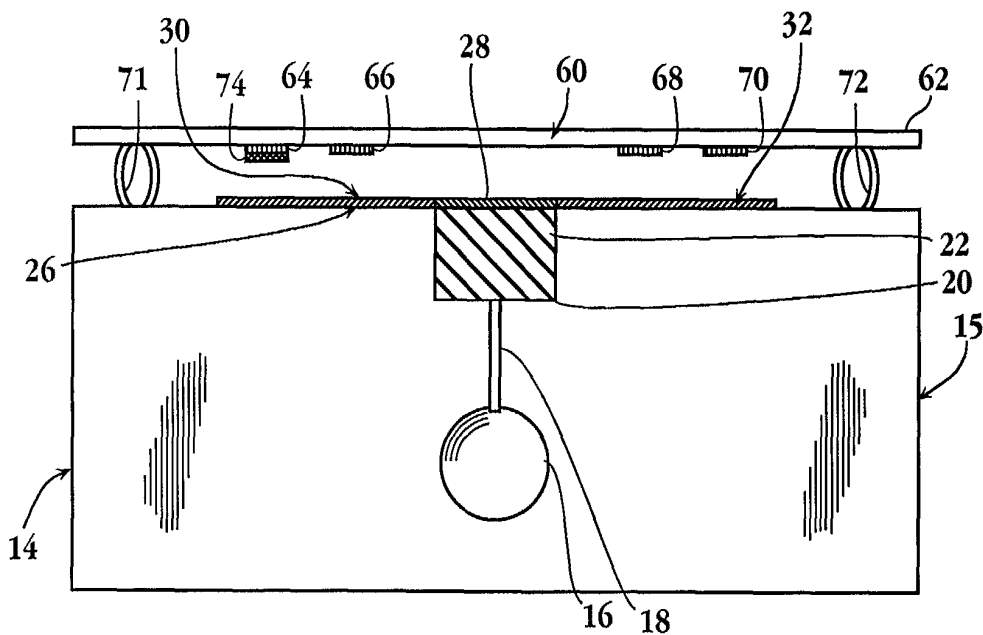

Fig. 1

Description

1. Field of the Invention.

[0001] The present invention relates to a method of determining the concentration of high density lipoprotein (HDL)-associated cholesterol in a blood-fluid sample, and a diagnostic assay device for carrying out the method.

2. Background of the Invention

[0002] The amount of cholesterol present in the blood is known to be related to the risk of coronary artery disease. Cholesterol circulates in the blood predominantly in protein-bound form. The proteins which transport cholesterol are the lipoproteins, which are subdivided into three classes based on their density. The very-low density lipoproteins (VLDL) are triglyceride-rich lipoproteins which are synthesized in the liver and ultimately converted to low-density lipoproteins (LDL), which transport most of the plasma cholesterol in humans. The high-density lipoproteins (HDL) are lipoproteins which are involved in the catabolism of triglyceride-rich lipoproteins, and in the removal of cholesterol from peripheral tissues and transport to the liver. An inverse relationship between serum HDL levels and risk of coronary disease has been established. In particular, if the proportion of serum cholesterol associated with HDL is low, the risk of coronary disease is increased.

[0003] In view of the importance of relative serum cholesterol levels in risk assessment and management of atherogenic disease, considerable effort has been spent screening large populations of both normal and high-risk individuals for serum levels of HDL, LDL, as well as total cholesterol and triglycerides. The effectiveness of treatments of high-risk individuals has been monitored by regular testing of serum levels of cholesterol in the various lipoprotein compartments.

[0004] One method for specific HDL cholesterol testing is based on the selective precipitation of non-HDL lipoproteins in serum by polyanionic compounds, such as dextran sulfate, heparin, and phosphotungstate, in the presence of a group-II cation, such as Mg^{2+} , Mn^{2+} , and Ca^{2+} . The specificity and degree of precipitation are dependent on a variety of factors, including the type and concentration of the polyanion/metal agent. In general, the order of precipitation of serum cholesterol particles, with increasing concentration of polyanion, is VLDL, LDL, and HDL. HDL usually remains soluble at concentrations of heparin or dextran sulfate which completely precipitate lower density particles, although minor apoE species of HDL may be co-precipitated with lower density particles. By selective precipitation of lower density particles, HDL serum cholesterol levels can be determined.

[0005] In a typical lipid assay procedure, a small volume of blood is drawn and centrifuged to produce a clear

plasma or serum sample fluid. The sample fluid is then aliquoted into several assay tubes, for determination of (a) total serum cholesterol, (b) triglycerides, and (c) HDL cholesterol. The HDL sample is precipitated, as above, and the lower density particles are removed by filtration or centrifugation prior to cholesterol detection. The samples are then reacted with an enzyme mix containing cholesterol esterase, cholesterol oxidase, peroxidase and a dye which can be oxidized to a distinctly colored product in the presence of H_2O_2 . The tubes may be read spectrophotometrically, and the desired total, HDL and LDL cholesterol values determined.

[0006] Despite the accuracy and reliability which can be achieved with the liquid-phase cholesterol assay just described, the assay has a number of limitations for use in widespread screening. First, the method uses a venous blood sample, requiring a trained technician to draw and fractionate the blood sample, and aliquot the treated blood to individual assay tubes. At least one of the sample tubes (for HDL determination) must be treated with a precipitating agent, and further processed to remove precipitated material. Although some of these procedures can be automated, analytical machines designed for this purpose are expensive and not widely available outside of large hospitals.

[0007] Co-owned U.S. Patent Nos. 5,213,964, 5,213,965, 5,316,196 and 5,451,370, each of which is incorporated herein by reference, disclose methods and assay devices which substantially overcome many of the above-mentioned problems associated with liquid-assay procedures for measuring serum cholesterol levels. In one embodiment, the device is designed for measuring the concentration of HDL-associated cholesterol in a blood sample also containing LDL and VLDL particles. The device includes a sieving matrix capable of separating soluble and precipitated lipoproteins as a fluid sample migrates through the matrix. A reservoir associated with the matrix is designed to release a precipitating agent, for selectively precipitating LDL and VLDL, as fluid sample is drawn into and through the matrix. This allows HDL separation from the precipitated lipoproteins, based on faster HDL migration through the sieving matrix. The fluid sample, thus depleted of non-HDL lipoproteins, then migrates to a test surface where it is assayed for cholesterol.

[0008] It was found that treatment of blood with reagents used in selectively precipitating non-HDL blood lipoproteins resulted in binding of a proportion of the HDL present in the sample to non-coated glass fibers, and that such binding of HDL to the glass fibers during filtering or transport often resulted in spuriously low HDL cholesterol values. This problem was addressed, in co-owned U.S. Patent No. 5,451,370, by coating the glass fibers in the matrix used for precipitation/sieving and transport of the filtered sample with a hydrophilic polymer or silylating reagent.

[0009] In addition to the necessity for such coating to minimize HDL loss, the above-referenced devices also

present the possibility of contamination of the flow transport path with the precipitating reagents. Such reagents could interfere with other assay chemistry taking place on other regions of the multi-assay device. The present invention addresses and overcomes these problems.

[0010] Further methods and devices for measuring HDL cholesterol in blood samples are disclosed in the EP-A-0 408 223 and the EP 0 415 298. Similar to the teaching of EP-A-0 408 223, the EP 0 415 298 describes a continuous method carried out on a test strip comprising the following steps and corresponding elements.

[0011] The blood sample is applied to a separation layer for separating cellular blood constituents. Driven by capillary forces or gravity, the sample flows through a further carrier containing soluble precipitating agents. After solved by said blood sample passing by, said precipitating agents precipitate non-HDL lipoproteins contained in the blood sample. In the next carrier allowing through-flow, three different functions are carefully executed at the same time. Said precipitated constituents are filtered from the blood sample to prevent their interference with the later HDL quantification. Further, the blood sample is transported to a position in front of the HDL-quantification carrier. Finally, said blood sample is stored in said carrier until the HDL-quantification step is started. Based on the simultaneous execution of these functions and their mutual interference, different disadvantages are related to this concept which affects the later HDL-quantification. Said carrier functioning as a reservoir allows further migration of the precipitated constituents to disturb the quantification. Following from the long-term storing of the blood sample, HDL is trapped by the carrier fibers and the carrier is partly clogged by the drying blood sample. As a further consequence, impregnated precipitating agents and addition agents may cause further reactions based on the long-term blood contact. Finally, said blood sample is quantified by an enzymatic reaction in a HDL-quantification layer where the content of HDL lipoproteins are determined. Based on the conceptual configuration of the HDL test method and the corresponding device including the storing before quantification of the blood sample, the HDL results are erroneously estimated.

[0012] It is therefore the problem of the present invention to provide a HDL assay device and method overcoming the above prior art disadvantages.

3. Summary of the Invention

[0013] The above problem is solved by an assay device according to claim 1 and 2 as well as a method according to claim 20 and 21 for the separation of non-HDL lipoproteins from biological liquids as e. g. a blood sample which realize a completely different concept compared to the prior art.

[0014] Said assay device for measuring serum cholesterol associated with high-density lipoproteins (HDL) in a blood fluid sample also containing low density lipo-

proteins (LDL) or very low density lipoproteins (VLDL), the device comprising a sample distribution matrix for distributing the blood fluid sample in said assay device; and a reagent pad containing a reagent effective to selectively remove non-HDL lipoproteins from the blood fluid sample; and a HDL assay element in which HDL concentration can be assayed, in direct contact with said reagent pad; wherein said reagent pad may be brought in fluid contact with said sample distribution matrix.

[0015] Compared to the prior art, a completely new concept for evaluating the HDL content in biological liquids is provided. As a main feature, the biological liquid, e. g. a blood sample, is processed as fast as possible. To this end, said reagent pad containing said reagent for selectively removing non-HDL lipoproteins from the blood fluid sample as well as said HDL assay element for HDL quantification are arranged in close proximity to limit the temporal contact of the blood sample with the present chemical reagents. By this arrangement, the new assay is qualified by a completely different dynamic of sample through-flow. This through-flow dynamic guarantees an optimized contact between the sample and the chemical reagents which is as time effective as needed. Further, said reagent pad is optimally adapted to support removing, e. g. precipitation and separation or binding, of non-HDL compounds. Although, a time-effective HDL testing is realized, the test method can be adapted to required environmental conditions. This means that the test method can be stopped after the sample application and pre-preparation for a desired time to e. g. adjust the surrounding atmosphere or adapt the environmental temperature to support the testing. To this end, the configuration of the sample distribution matrix is designed to additionally serve as a reservoir if needed.

[0016] According to a further preferred embodiment of the present invention, an assay device is disclosed for measuring serum cholesterol associated with high-density lipoproteins (HDL) in a blood fluid sample also containing low density lipoproteins (LDL) or very low density lipoproteins (VLDL), said device comprising a sample distribution matrix effective to distribute a blood fluid sample from a sample application region within the matrix to one or more sample collection regions within the matrix; a HDL assay element, in which HDL concentration can be assayed, spaced apart from said sample distribution matrix, a reagent pad, disposed between said HDL assay element and said sample distribution matrix, and spaced apart from said matrix, said reagent pad containing a reagent effective to selectively remove non-HDL lipoproteins from the fluid sample, and mounting means effective (a) to maintain said device in a sample-distribution position, wherein said HDL assay element and reagent pad are spaced apart from said matrix, and (b) to transfer said device to a test position, whereby the HDL assay element is placed or maintained in contact with the reagent pad, and the reagent pad is, concurrent with or subsequent to said contact, brought

into contact with said matrix.

[0017] Furthermore preferred, the device comprises a reaction bar which is fixed by mounting means to said main body to establish a displacement of said reaction bar between a sample distribution position in which said HDL assay element and said reagent pad are spaced apart from said sample distribution matrix and a test position in which said HDL assay element in contact with said reagent pad is brought into contact with said sample distribution matrix; and additional test pads attached together with said reagent pad and said HDL assay element to a lower surface of said reaction bar, such that said pads are brought into fluid contact with said sample distribution matrix when said reaction bar is transferred to a test position and that said fluid contact is interrupted when said reaction bar is displaced in said spaced position.

[0018] The above cassette or main body comprises a reaction bar which can be moved from spaced apart from the test pad (spaced position) in the test position e. g. by putting said device in a corresponding analyzer. Based on this displacement from the spaced position to the test position, the HDL assay element as well as the reagent pad is brought into fluid contact with said sample distribution matrix containing the blood sample to start said non-HDL removing as well as said HDL determination during flow-through of the blood fluid sample through said reagent pad and said HDL assay element. The test is then automatically completed.

[0019] According to a preferred embodiment of said assay device, a lower surface of the HDL assay element is attached to an upper surface of the reagent pad.

[0020] Based on this configuration, a fast through-flow of the sample is realized which limits the temporal contact of the blood sample with the corresponding reagents. Further, a space saving arrangement is guaranteed by not using further sandwiched layers between said HDL assay element and said reagent pad.

[0021] It is furthermore preferred according to the invention that said sample distribution matrix is connected to a sieving pad.

[0022] This arrangement allows the provision of an appropriate blood fluid sample reservoir by means of said sieving pad and said sample distribution matrix as well as an upstream filter for filtering said cellular blood components by means of said sieving pad.

[0023] Further preferably according to the invention, said device comprises a main body having a well for containing said blood fluid sample, in fluid communication with said sieving pad and said sample distribution matrix to which said blood fluid sample is transferred.

[0024] The above device is according to a preferred embodiment accommodated in a cassette forming the main body. Said body has a well for receiving e. g. the drop-like blood sample. Said well cooperates with said sample distribution matrix via said sieving matrix so that the blood sample is separated from cellular components. Further, some kind of a channel system is pro-

vided which transports said blood sample from said dwell to said sample distribution matrix.

[0025] According to a further preferred embodiment of the present invention, said reaction bar is optically transparent, includes optically transparent windows or openings through which said test pads and said HDL assay element are visible. Correspondingly, said HDL assay element contains reagents which, in the presence of HDL cholesterol, produce a change in the HDL assay element which can be detected optically. Thus, the HDL content in the blood sample is preferably evaluated using color reactions which can be easily evaluated.

[0026] It is preferred to provide said reagent pad as well as said HDL assay element like an asymmetric polymeric membrane, having a smaller pored surface and an opposite, larger pored surface wherein the larger pored surface of said HDL assay element faces the reagent pad.

[0027] Further according to a preferred embodiment of the present invention, said reagent for selectively removing non-HDL lipoproteins from the blood sample is immobilized to said reagent pad.

[0028] In another preferred embodiment of the present invention, the HDL assay element comprises a biosensor. Preferably, the biosensor is effective to electrochemically measure production of oxygen or hydrogen peroxide, which is in turn dependent on HDL-associated cholesterol concentration within the sample fluid. Additional assay elements may also comprise biosensors, effective to electrochemically measure production of oxygen or hydrogen peroxide, which is in turn dependent on analyte concentration within the sample fluid.

[0029] Additionally, the present invention provides a method of measuring serum cholesterol associated with high-density lipoproteins (HDL) in a blood fluid sample also containing low density lipoproteins (LDL) or very low density lipoproteins (VLDL), comprising the following steps: applying said blood fluid sample to a sample distribution matrix; guiding said blood fluid sample through a reagent pad containing a reagent effective to selectively remove non-HDL lipoproteins from the blood fluid sample; and determining the content of HDL lipoproteins in said blood fluid sample by a HDL assay element in which HDL concentration can be assayed; wherein the fluid contact is selectively establishable between said sample matrix and said reagent pad which is connected to said HDL assay element.

[0030] As already explained above, the present invention realizes a different concept compared to the prior art. It is qualified by the essential features that the sample preparation as well as the HDL evaluation are carried out in separated steps. The preparation step guarantees that the biological liquid, e. g. the blood sample, is prepared and adapted to the subsequently following HDL evaluation step. Sample preparation includes for example filtering of cellular blood components as well as storing of the blood sample and adaptation of

the blood sample to the test requirements/conditions as temperature, pressure and environmental atmosphere. The HDL evaluation step realizes a time-effective removing, i. e. precipitation or binding, of non-HDL constituents and additionally a reliable HDL quantification. By this measure, the temporal contact of the blood sample with the different reagents is reduced and any chemical interference with the HDL evaluation is prevented. Further, said blood sample is not stored in a small pored carrier adapted to filtering, since the HDL evaluation step is executed in a short period.

[0031] According to a further preferred embodiment of the present invention, a method is disclosed of measuring serum cholesterol associated with high-density lipoproteins (HDL) in a blood fluid sample also containing low density lipoproteins (LDL) or very low density lipoproteins (VLDL), comprising the following steps: contacting the sample with an absorptive sample distribution matrix through which said sample is distributed to one or more sample collection sites; bringing into contact with such a sample collection site, a first surface of a reagent pad, to which said sample is transferred, containing a reagent effective to selectively remove non-HDL lipoproteins from the fluid sample, wherein an opposite surface of said reagent pad is in simultaneous contact with an HDL assay element, in which HDL concentration can be assayed, such that successive sample volumes proceed from said reagent pad to said HDL assay element, and determining the level of HDL cholesterol in said sample by optical detection at said HDL assay element.

[0032] According to a preferred embodiment of the present invention, a step of breaking said contact between the sample collection site and said reagent pad is incorporated when a desired amount of sample has been transferred.

[0033] By the above measures, on the one hand an effective sample distribution is realized and on the other hand a sample overload of the corresponding pads is prevented.

[0034] Furthermore preferred, said reagent pad and said HDL assay element comprises an asymmetric polymeric membrane, having a smaller pored surface and an opposite, larger pored surface wherein said reagent pad is oriented such that its smaller pored surface faces said HDL assay element. The larger pored surface of the HDL assay element faces said reagent pad.

[0035] In another preferred embodiment of the present invention, a biosensor for determining the HDL content of said blood fluid sample is used which is comprised in said HDL assay element, as described above.

[0036] These and other objects and features of the invention will become more fully apparent when the following detailed description of the invention is read in conjunction with the accompanying drawings.

3. Brief Description of the Drawings

[0037]

5 Figure 1 is a side view of a multi-analyte assay device constructed in accordance with one embodiment of the invention;

10 Figure 2 is a perspective view, in exploded form, of a multi-analyte assay device constructed in accordance with one embodiment of the invention; and

15 Figure 3 is a cross section view of two contacting asymmetric membranes, for use as precipitating reagent pad and HDL assay element in one embodiment of the invention, in a preferred orientation.

4. Detailed Description of the Invention

I. Assay Device

[0038] Figures 1 and 2 illustrate two embodiments of a multiple-analyte assay device 14 constructed in accordance with the present invention, with Figure 2 shown in exploded format. The device is designed particularly for determining serum cholesterol associated with HDL (also referred to as HDL-associated cholesterol or simply HDL cholesterol) using a small volume of blood sample, typically between 10-50 μ l of blood. Other assays, such as total cholesterol or triglyceride level, can be determined simultaneously from the same sample. Determination of HDL-associated cholesterol may also be referred to simply as determination of HDL or an HDL assay.

25 **[0039]** The apparatus includes a main body or support 15 which defines a well 16 dimensioned and sized to receive a quantity of a blood sample, typically between about 25-50 μ l. The well is in fluid contact with a sieving pad 22, which may be carried in a notched region 20 formed in the upper edge of the support. The fluid contact may be direct, or as in the device shown in Fig. 1, provided by a capillary conduit 18 formed in the plate at the base of the well. The support is preferably a plastic plate, with the well, notched region and/or capillary conduit formed by standard molding or machining methods.

35 **[0040]** Sieving pad 22 carried in region 20 functions to partially remove large particulate matter (including blood cells) as the sample migrates through the pad matrix in a bottom-to-top direction as shown in the figure. Pad 22 is preferably formed of a glass fibrous matrix of material designed to draw aqueous fluid by surface wetting, and to retard the movement of blood cells as the blood sample is drawn through the matrix. That is, the pad serves as a chromatographic medium for separating cell-size particles from soluble serum components on the basis of different migration rates through the medium. One exemplary pad is a glass fiber filter, such as a GF/D or PD008 filter supplied by Whatman, having a

packing density of about 0.16 g/cm³. The pad is cut to side dimensions of about 3 X 8 mm, and a thickness of about 1 mm. The pad is dimensioned to absorb a defined volume of sample fluid, preferably between about 15-25 μ l. Sieving pad 22 may additionally contain red blood cell capture reagents, such as lectins, antibodies specific for red blood cell surface membrane proteins, thrombin, or ion exchange agents.

[0041] The sieving pad, 22, in turn, contacts an elongate strip or sample distribution matrix 26 which extends along the upper edge of plate 15. This strip may also be supported by foam cushions 27 or other supports, as shown in Fig. 2. Matrix 26 serves to distribute sample fluid from a central sample-application region 28 of the strip, which is in fluid contact with pad 22, to opposite sample-collection regions 30, 32 adjacent the ends of the matrix. The matrix is preferably formed of glass fibers. The packing density and thickness of the matrix are such as to absorb and distribute volumes of sample fluid, e.g., 10-25 μ l, supplied to the sample-application region of the strip to the sample-collection regions of the strip. The matrix has a preferred packing density between about 0.16 g/cm³ and 4.0 g/cm³. One exemplary strip material is a F-165-25A glass fiber filter available from Whatman, having a packing density of about 0.2 gm/cm³, a width of about 3 mm, a length of about 3 cm, and a thickness of about 0.12 mm.

[0042] Because the sample does not contact the glass fibers used for the sieving pad and sample distribution matrix in the presence of precipitation or binding reagent, coating as described in U.S. Patent No. 5,451,370, is not required to prevent adhesion of HDL. However, if desired, the glass fibers may be coated, e.g. with 5% polyvinyl alcohol by weight.

[0043] Device 14 also includes a reaction bar 60 composed of an elongate support 62, and multiple wettable, absorbent reaction test pads 66, 68, 70 and a HDL assay element 64, carried on the lower surface of the support, at the positions shown. Support 62 is transparent or has transparent windows, e.g. window 76 (Fig. 2), which allow the pads and said HDL assay element to be viewed through the support. According to a further preferred embodiment of the present invention, said support 62 has openings through which the pads can be viewed. The reaction test pads in the reaction bar are attached to the support by a transparent or translucent adhesive material, or by sonic welding or other suitable bonding method. Each pad used in a particular assay contains analyte-dependent reagents effective to produce an analyte-dependent change in the pad which can be detected optically, either visually or by a detector, in a known manner, as described further below. All or any integral subset of the pads may be employed in a particular assay.

[0044] Desirably, the reaction test pads are porous polymer membranes, preferably having a thickness of about 100-150 μ m and side dimensions of about 3 mm. The absorption volume of each pad is preferably be-

tween about 0.5-1.0 μ l. In a preferred embodiment, the reaction pads, and in particular the HDL assay element 64 used for HDL assay, are asymmetric membranes; that is, membranes having a porosity gradient across the thickness of the membrane, as described further below.

[0045] The reaction bar is mounted on support 15 by mounting means effective to (a) maintain the device in a sample-distribution position, wherein the test pads and reagent pads are spaced apart from the matrix, and to (b) transfer the device to a test position, where the HDL assay element is placed (or maintained, if the two pads are attached together) in contact with the reagent pad, and the reagent pad is, concurrently or subsequently, brought into contact with matrix 26 at a sample collection site. The mounting means can also be used to break such contact after a desired amount of sample has entered the test pads and said HDL assay element 64, and/or after a determined contact time, by transferring the device from the test position to a position in which the test pads, said HDL assay element 64 and said reagent pads are spaced apart from the matrix (which may be the same as the "sample-distribution" position). Such transferring can be controlled by monitoring the reflectance at the top surface of the test pad, which reflects extent of wetting, as described in co-owned U.S. Patent No. 5,114,350. Alternatively, when the absorption capacity and rate of sample uptake of the pad material are known, the quantity of sample can be controlled with sufficient accuracy simply by using a predetermined contact time.

[0046] The mounting means can include, for example, a pair of resilient members, such as elastomeric blocks 71, 72, which act to bias the pads toward a non-transfer or sample-distribution position, at which the pads are spaced apart from the sample distribution matrix, with a spacing typically of between about 0.5 to 1.0 mm. By compression or release of the resilient members, contact between sample distribution matrix 26 and reagent pad 74 and HDL assay element 64 can be selectively established and separated. The support blocks could be compressed by means of springs or a piston-like action. Alternatively, external mechanical devices could engage the main body 15 and/or support 62 and move one towards the other. Such devices may include conventional components such as clamps, pistons, stepper motors, worm gears, or the like. An exemplary system is the Cholestech LDX[®] Analyzer, a self-contained, automated analyzer advantageous for use with assay devices such as described herein.

[0047] In a preferred embodiment, said HDL assay element 64 placed at an arbitrary position and used for assaying HDL, has affixed thereto a reagent pad 74, as shown in the Figures. Alternatively, such a reagent pad 74 may be supported in a substantially coplanar position between the HDL assay element 64, with which it may or may not be in direct contact, and a sample collection region of matrix 26. For example, a compressible sup-

port element could support the reagent pad above the matrix, such that movement of the reaction bar towards the main body (or vice versa) would first bring said HDL assay element 64 into contact with the upper surface of reagent pad 74, and would then bring the lower surface of the reagent pad into contact with the sample distribution matrix. The reagent pad preferably has a thickness of about 100-150 μm , side dimensions of about 3 mm, and an absorption volume of about 0.5-1.0 μl .

[0048] Reagent pad 74, preferably in contact with said HDL assay element 64 contains a reagent used to selectively remove LDL and VLDL particles from the fluid sample. Such reagents, which are known in the art as precipitating reagents, include polyanionic compounds, such as sulfonated polysaccharides, heparin, or phosphotungstate, in the presence of a group-II cation, such as Mg^{2+} , Mn^{2+} , and Ca^{2+} . A preferred reagent is a sulfonated polysaccharide, such as dextran sulfate, having a typical molecular weight of 50,000 to 500,000 daltons, in combination with magnesium acetate or chloride, buffered to maintain neutral pH.

[0049] The reagent pad is effective to entrap bound or precipitated non-HDL lipoproteins within the reagent pad and prevent them from entering HDL assay element 64. While a glass fiber filter can be used for such a purpose, such glass fibers should be coated to prevent binding HDL in the presence of the reagents, as described in U.S. Patent No. 5,451,370, cited above. In a preferred embodiment, reagent pad 74 is composed of a porous polymeric membrane, as described further below.

[0050] The reagent pad contains reagents for selective removal of non-HDL lipoproteins, as described above. In one embodiment, a membrane is impregnated with such reagents. For example, a polysulfone asymmetric membrane, as described below, is impregnated with an aqueous solution containing dextran sulfate and a magnesium salt, such as magnesium acetate, and dried. An exemplary procedure for preparing such membranes for incorporation into the device is described in Example 1. In this case, the soluble precipitating reagents are released into the sample solution as it penetrates the membrane.

[0051] In another embodiment, the reagents are immobilized to the membrane. Preferably, the negatively charged reagent, e.g. dextran sulfate, is immobilized by electrostatic forces and/or covalently to a membrane having positively charged surface groups. An exemplary material for this purpose is a nylon membrane having surface quaternary ammonium groups, such as the AM080 membrane provided by Cuno Corp. (Meridian, CT).

[0052] In this case, the membrane acts as an affinity separation medium, such that non-HDL lipoproteins bind to the reagent affixed to the membrane, rather than precipitating, and are thereby separated from the sample fluid.

[0053] Other commercial polymeric membranes hav-

ing a cationic surface include Immobilon-Ny+™ (Millipore Corp., Bedford, MA), Zetabind® (also from Cuno Corp.), GeneScreen® (NEN/DuPont, Boston, MA), Hybond N+ (Amersham, Piscataway, NJ) and Posidyne® (Pall Corp., Glen Cove, NY). U.S. Patent No. 5,543,054 (Charkoudian *et al.*) describes a method for covalently binding negatively charged carbohydrates to a membrane having reactive moieties in proximity to positively charged moieties on its surface. The membrane is, for example, a porous polymer, e.g. polytetrafluoroethylene, polyvinylidene fluoride, polyester, polyamide, polycarbonate, polypropylene, polymethylmethacrylate, polymethacrylate, polysulfone, or polystyrene, coated with Hercules R-4308™, a polyamido-polyamine epichlorohydrin resin.

[0054] In one embodiment, reagent pad 74 is composed of an asymmetric membrane; that is, a membrane having a pore size gradient across its thickness. An asymmetric membrane is particularly preferred for use with precipitating reagents incorporated into the membrane in soluble form, for optimum entrapment of precipitate. The preparation of asymmetric membranes is described, for example, in U.S. Patent Nos. 4,629,563, 5,171,445, 5,886,059, 5,536,408, 5,562,826, and 4,774,192; in D. R. Lloyd, "Materials Science of Synthetic Membranes", ACS Symposium 269: 1-21 (1985). They are commercially available in a variety of pore sizes and pore size ratios. Materials of fabrication include polysulfones, polyethersulfones, polyamides, polyether amides, polyurethanes, cellulose acetate, polyvinyl pyrrolidone, polystyrenes and modified polystyrenes, as well as blends, copolymers, and laminar composites. An exemplary asymmetric membrane is a polysulfone or polyethersulfone membrane, such as FILTERITE™ membranes provided by USF Filtration and Separations (San Diego, CA). Minimum pore sizes typically range from 0.01 to 1.0 μm , with maximum/minimum pore size ratios up to 100 or more. Thickness is typically 100-150 μm .

[0055] The asymmetric membrane is preferably oriented with its larger pored surface facing the sample application region; that is, facing downward in Figures 1 and 2, and its smaller pored surface facing, and preferably contacting, a reaction test pad, e.g. HDL assay element 64, containing reagents for assaying HDL level, as described further below. This orientation allows free access of sample into the pad through the larger pores, and prevents passage of precipitated material, formed as the solution contacts soluble precipitating agent, through the smaller pores, which are generally 1 μm or less in diameter. This pore size is also preferred for non-asymmetric membranes.

[0056] In one embodiment, reagent pad 74 consists of a single membrane. The invention also contemplates the use of multiple stacked membranes, i.e. up to about six, where at least one and preferably each membrane contains reagents for binding or precipitation of non-HDL lipoproteins, for reagent pad 74. They may

contain immobilized reagent, as described above, or they may be impregnated with soluble reagent. In the latter case, asymmetric membranes are preferred, and are preferably oriented such that the smaller pored surface of the uppermost membrane faces HDL assay element 64, and the larger pored surface of the lowest membrane faces the sample application region.

[0057] In one preferred embodiment, said HDL assay element 64 is also a polymeric membrane, containing reagents for assaying HDL level, and may be an asymmetric membrane as described above. In order to present the more uniform surface for optical scanning and quantitation of assay results, an asymmetric membrane employed for said HDL assay element 64 is oriented with its smaller pored surface facing upward, and its larger pored surface facing reagent pad 74.

[0058] Alternatively, an asymmetric membrane employed for said HDL assay element 64 may be oriented with its larger pored surface facing upward and its smaller pored surface facing reagent pad 74. This orientation is more suitable for assays in which a visual, qualitative reading is to be made from the upper surface.

[0059] If desired, HDL assay reagents, such as peroxidase, may be immobilized to said HDL assay element membrane, according to well known methods for enzyme immobilization. (See e.g. U.S. Patent No. 4,999,287; U.S. Patent No. 5,419,902; Blum, L.J. *et al.*, *Anal. Lett.* 20(2):317-26 (1987); Kiang, S.W. *et al.*, *Clin. Chem.* 22(8):1378-82 (1976); Guilbault, G.G., Ed., *Modern Monographs in Analytical Chemistry, Vol. 2: Analytical Uses of Immobilized Enzymes* (1984); Torchilin, V. P., *Progress in Clinical Biochemistry and Medicine, Vol. 11: Immobilized Enzymes in Medicine* (1991).) In another embodiment, a reagent, such as catalase, which is effective to decompose any generated hydrogen peroxide that might diffuse downward from said HDL assay element 64, may be included in reagent pad 74.

[0060] In a preferred embodiment, where two attached polymeric membranes are employed for said HDL assay element 64 and reagent pad 74, respectively, the appropriate reagents are impregnated or immobilized, and the membranes are processed as a two-membrane layer for incorporation into the assay device during manufacture. An exemplary two-membrane layer comprising two asymmetric membranes is shown in cross section in Fig. 3, with the preferred orientation shown, with larger pores at 78 and smaller pores at 80.

[0061] In a further embodiment, the HDL assay element 64 comprises a biosensor, as described, for example, in PCT Pubn. No. WO 9958966 (Dobson *et al.*), which is incorporated herein by reference. This document discloses a microscale biosensor device, comprising a conducting surface, a layer of dielectric material overlying the conducting surface, and a plurality of pores extending through the dielectric layer. Each of the pores can act as a microelectrode, converting a chemical response into an electrical signal, by virtue of a biopolymer within the pore in contact with the conducting surface.

In use, a fluid containing an analyte to be assayed is applied to the pores so as to be in contact with the biopolymer. In the present HDL assay device, this can be achieved by placing reagent pad 74 in fluid contact with the HDL assay element 64; that is, the pore-containing surface of the biosensor.

[0062] A counter electrode is provided which is in electrical contact with the conducting surface via the sample fluid. A voltage is applied between the counter electrode and the conducting surface, and the current that flows therebetween is measured. The measured current is indicative of the amount of a chosen analyte in the assayed fluid.

[0063] The microelectrodes preferably function as amperometric biosensors. Briefly, an amperometric biosensor functions by the production of a current when a potential is applied between two electrodes. An example is the Clark oxygen electrode, which measures current produced by reduction of oxygen or oxidation of hydrogen peroxide.

[0064] The dependence of such biosensors on dissolved oxygen concentration can be overcome by the use of 'mediators', which transfer the electrons directly to the electrode, bypassing the reduction of the oxygen co-substrate. Ferrocenes represent a commonly used family of mediators.

[0065] The biopolymer within the microelectrode pores is typically an enzyme, such as, for the measurement of HDL-associated cholesterol, cholesterol oxidase. Cholesterol is oxidized by cholesterol oxidase to the corresponding ketone, liberating hydrogen peroxide, which can then be converted to water and oxygen by the enzyme peroxidase. Either oxygen or hydrogen peroxidase is then measured electrochemically at the biosensor.

II. Assay Method

[0066] In operation, a blood sample is placed into well 16, and is imbibed by capillary action through sieving matrix 22, where large particulates, including red blood cells, are removed, and thence into sample distribution matrix 26. These steps take place while the device is in a "sample-distribution" position, such that the sample distribution matrix does not contact the reagent or test pads or HDL assay element. When the serum sample reaches the sample-collection sites, such as sites 30 and 32 adjacent the ends of matrix 26, the device is adjusted to a test position, preferably by moving reaction bar 60, to place test pads 66, 68, and 70 and reagent pad/HDL assay element 74/64 (in the embodiment shown in the Figures) in contact with the matrix. In this position, sample fluid in the matrix is drawn into each contacted pad by capillary flow, with fluid movement occurring in a direction normal to the pad surfaces. The plate is held at this position until a desired degree of wetting of the pads is achieved. The plate is then moved, if desired, to break contact between the sample distri-

bution matrix and the test pads/HDL assay element and reagent pad(s), when a desired amount of sample fluid has entered the test pads/HDL assay element, and/or after an appropriate contact time, e.g. as described in Example 2 below.

[0067] In embodiments of the device in which reagent pad 74 is not affixed to HDL assay element 64, respective movement of the reaction bar and main body toward each other, typically by moving the reaction bar downward, first places HDL assay element 64 in contact with reagent pad 74, to approximate the arrangement of elements shown in the Figures, and further movement then places the reagent pad in contact with the sample distribution matrix. Contact is maintained until a desired degree of wetting is achieved, as described above. In a further preferred embodiment of the device, the reagent pad 74 is in direct contact with said HDL assay element 64. Said reagent pad 74 and said HDL assay element 64 are brought into contact with said sample distribution matrix 26 by correspondingly moving said reaction bar 60 toward said sample distribution matrix 26.

[0068] Sample serum entering reagent pad 74 contacts precipitating or binding reagent contained in the membrane, such that non-HDL lipoproteins are selectively precipitated and retained by filtration, in the case of soluble reagent, or bound to the membrane, in the case of immobilized reagent. The membrane is thus effective to entrap non-HDL lipoproteins, while allowing passage of serum containing liquid-phase HDL to HDL assay element 64. The HDL assay element 64 contains reagents for quantification of HDL-associated cholesterol. Preferably, these include cholesterol esterase, for releasing free cholesterol from HDL, cholesterol oxidase, for producing H_2O_2 by reaction with free cholesterol, peroxidase, and a coupled dye system which is converted, in the presence of peroxidase and H_2O_2 , to a distinctively colored signal reaction product.

[0069] During operation, as sample fluid passes through the HDL assay path, comprising pads 74 and 64, its leading edge passes in an upward direction through pad 74, where non-HDL lipoproteins react and are entrapped, and directly to adjacent assay pad 64, where HDL reacts with the assay reagents therein, for measurement of HDL-associated cholesterol. Further portions of sample continue to be in contact with pad 74 during this time, and proceed from pad 74 to pad 64 in a like manner, until the absorption capacity of pad 64 is reached. Accordingly, quantification of HDL-associated cholesterol in the HDL assay element 64 occurs concurrently with the precipitation or binding reaction taking place in reagent pad 74. Preferably, the volume of sample fluid transferred to the HDL assay path (comprising pad 74 and element 64) from the sample distribution matrix is equal to or greater than the absorption capacity of HDL assay element 64, and less than or equal to the combined absorption capacity of HDL assay element 64 and reagent pad 74.

[0070] The remaining test pads also contain assay re-

agents which produce a change in the pad which can be detected optically, either visually or by a detector, in a known manner. One advantage of the current device and method is that the sample distribution path does not contain non-HDL precipitating or binding reagents; such reagents are present only in reagent pad 74. Therefore, the possibility of interference from these reagents, in assays of analytes other than HDL, is eliminated.

[0071] Preferably, each of the test pads contains reagent components for converting H_2O_2 to a colored signal reaction product. Such components include peroxidase and a coupled dye system which is converted by the peroxidase, in the presence of H_2O_2 , to a distinctively colored signal reaction product. Enzymatic color reactions which employ a variety of substrate-specific oxidases, for enzymatic generation of H_2O_2 , and subsequent oxidation of a dye to form a colored reaction product, are well known.

[0072] Preferably according to a further embodiment of the present invention, each of the test pads and the HDL assay element contains reagent components for producing H_2O_2 via reaction of the analyte with an enzyme; the H_2O_2 subsequently converts a substrate reagent to a colored signal reaction product, or is measured electrochemically, as described above.

[0073] A device having four or more reaction pads can be used to simultaneously measure HDL cholesterol (HDL), glucose, total cholesterol (TCh), and triglyceride lipid (TG). Each pad contains the above-described common pathway components (peroxidase and a coupled dye system) such that generated H_2O_2 produces a distinctively colored signal reaction product. The total cholesterol test pad, which is exposed to serum without exposure to a precipitating or binding reagent, and the HDL assay element 64 each include, in addition to the common pathway components, cholesterol esterase, for releasing esterified cholesterol in free-cholesterol form from serum lipoproteins, including HDL, LDL, and VLDL particles, and cholesterol oxidase, for producing H_2O_2 by reaction with free cholesterol in the sample fluid, as described above. The glucose assay pad includes glucose oxidase, in addition to the common-pathway components. The triglyceride pad includes, in addition to the common-pathway components, lipase, L-glycerol kinase, and L-glycerol-3-phosphate oxidase, for generating H_2O_2 from triglyceride, via the intermediate L-glycerol-3-phosphate. The serum sample drawn into the TG pad is not exposed to precipitating or binding reagents, and thus contains all of the serum lipoproteins, so the TG signal represents total serum triglycerides.

[0074] Reference standard pads may also be employed; see, for example, the system described in co-owned U.S. Patent No. 5,114,350, which is incorporated herein by reference.

[0075] As noted above, one advantage of the current device and method is that the sample distribution matrix does not contain non-HDL precipitating or binding reagents; such reagents are present only in reagent pad

74. Therefore, the possibility of interference by these reagents, in assays of analytes such as total serum cholesterol and total triglycerides, is eliminated.

Example 1: Preparation of Reagent Membrane with Soluble Precipitant and HDL Test Membrane

[0076] To prepare a reagent membrane with soluble precipitant, an aqueous solution containing 1 mg/ml dextran sulfate (500,000 MW) and 12.5 mM Mg(OAc)₂ is dispensed onto a polysulfone asymmetric membrane 0.22 inches in width. The membrane thickness is 127 +/- 5 μm, with a bubble point of 85 +/- 5 psi. The reagent is dispensed at a rate of 16.6 ul/inch, and the membrane is dried for 20 minutes at 50°C in a continuous roll process. Lengths of e.g. 100 feet are prepared in this manner and cut to fit the assay devices.

[0077] To prepare an HDL reaction membrane, a similar asymmetric polysulfone membrane is impregnated with the following aqueous formulation: cholesterol oxidase 36.5 Units/ml, cholesterol esterase 215 Units/ml, peroxidase 200 Units/ml, 4-aminoantipyrine 1.88 μm/ml, and TOOS (3-[ethyl(3-methylphenyl)amino]-2-hydroxy propanesulfonic acid) 12.05 μm/ml. Dispense rate and drying time are as for the reagent membrane, above.

[0078] The two membranes may be attached separately (sequentially) to the reaction bar by ultrasonic welding, or they may be attached simultaneously with a single ultrasonic weld step.

Example 2. Assay Procedure

[0079] The following assays were carried out in an LDX® analyzer, using reagent pads and HDL assay elements prepared essentially as described in Example 1. Sample (35 μl of serum or whole blood) was applied to the sample well and allowed to distribute through the sample distribution matrix for 2 minutes. The reaction bar was then contacted with the matrix for 3 seconds, a time sufficient to transfer enough serum to fill the reagent pad and test pad/HDL assay element (combined capacity about 1.5 μl), after which the bar was returned to its original position. Reflectance readings were taken from the upper surface of the HDL assay element every 3 seconds for 150 seconds, to monitor the progress of the HDL assay reaction. The minimum reflectance value attained was then converted to mg/dL of HDL cholesterol according to a previously established calibration curve.

[0080] The concentration values below (mg/dL) are from five serum samples analyzed as described above and on a Beckman reference analyzer, showing excellent correlation.

Sample No.	HDL assay	Beckman reference
A010904	23.8	24.5

(continued)

Sample No.	HDL assay	Beckman reference
10906	43.0	41.9
10502	61.5	59.6
10801	80.6	78.7
10805	92.4	87.2

Claims

1. An assay device (14) for measuring serum cholesterol associated with high-density lipoproteins (HDL) in a blood fluid sample also containing low density lipoproteins (LDL) or very low density lipoproteins (VLDL), the device comprising
 - a. a sample distribution matrix (26) for distributing the blood fluid sample in said assay device (14); and
 - b. a reagent pad (74) containing a reagent effective to selectively remove non-HDL lipoproteins from the fluid sample; and
 - c. a HDL assay element (64) in which HDL concentration can be assayed, in direct contact with said reagent pad (74); wherein
 - d. said reagent pad (74) may be brought in fluid contact with said sample distribution matrix (26).

2. An assay device (14) for measuring serum cholesterol associated with high-density lipoproteins (HDL) in a blood fluid sample also containing low density lipoproteins (LDL) or very low density lipoproteins (VLDL), the device comprising:
 - a. a sample distribution matrix (26) effective to distribute a blood fluid sample from a sample application region within the matrix (26) to one or more sample collection regions (30, 32) within the matrix (26);
 - b. an HDL assay element (64), in which HDL concentration can be assayed, spaced apart from said sample distribution matrix (26),
 - c. a reagent pad (74), disposed between said HDL assay element (64) and said sample distribution matrix (26), and spaced apart from said matrix (26), said reagent pad (74) containing a reagent effective to selectively remove non-HDL lipoproteins from the fluid sample, and

- d. mounting means (71, 72) effective (a) to maintain said device (14) in a sample-distribution position, wherein said HDL assay element (64) and reagent pad (74) are spaced apart from said matrix (26), and (b) to transfer said device (14) to a test position, whereby the HDL assay element (64) is placed or maintained in contact with the reagent pad (74), and the reagent pad (74) is, concurrent with or subsequent to said contact, brought into contact with said matrix (26).
3. The device (14) of claim 1, further comprising a reaction bar (60) which is fixed by mounting means (71, 72) to said main body (15) to establish a displacement of said reaction bar (60) between a sample distribution position in which said HDL assay element (64) and said reagent pad (74) are spaced apart from said sample distribution matrix (26) and a test position in which said HDL assay element (64) in contact with said reagent pad (74) is brought into contact with said sample distribution matrix (26); and additional test pads (66, 68, 70) attached together with said reagent pad (74) and said HDL assay element (64) to a lower surface of said reaction bar (60), such that said pads (66, 68, 70) are brought into fluid contact with said sample distribution matrix (26) when said reaction bar (60) is transferred to a test position and that said fluid contact is interrupted when said reaction bar (60) is displaced in said spaced position.
 4. The device (14) of one of the preceding claims, wherein a lower surface of the HDL assay element (64) is attached to an upper surface of the reagent pad (74).
 5. The device (14) of one of the preceding claims, wherein said sample distribution matrix (26) is connected to a sieving pad (22).
 6. The device (14) of claim 5, further comprising a main body (15) having a well (16) for containing said sample, in fluid communication with said sieving pad (22) and said sample distribution matrix (26) to which said blood fluid sample is transferred.
 7. The device (14) of claim 6, wherein said reaction bar (60) is optically transparent or includes optically transparent windows or openings through which said test pads (66, 68, 70)/ HDL assay element (64) are visible.
 8. The device (14) of one of the preceding claims, wherein said reagent includes a sulfonated polysaccharide.
 9. The device (14) of one of the preceding claims, wherein said HDL assay element (64) contains agents which, in the presence of HDL cholesterol, produce a change in said HDL assay element (64) which can be detected optically.
 10. The device (14) of one of the preceding claims, wherein said reagent pad (74) comprises a porous polymeric membrane.
 11. The device (14) of claim 10, wherein said reagent pad (74) is an asymmetric polymeric membrane, having a smaller pored surface and an opposite, larger pored surface.
 12. The device (14) of claim 11, wherein said membrane is oriented such that its smaller pored surface faces the HDL assay element (64).
 13. The device (14) of one of the preceding claims, wherein said HDL assay element (64) is a porous polymeric membrane.
 14. The device (14) of claim 13, wherein said HDL assay element (64) is an asymmetric polymeric membrane, having a smaller pored surface and an opposite, larger pored surface.
 15. The device (14) of claim 14, wherein said membrane is oriented such that its larger pored surface faces the reagent pad (74).
 16. The device (14) of claim 15, wherein each of said HDL assay element (64) and said reagent pad (74) is an asymmetric polymeric membrane, and said membranes are laminated such that the smaller pored surface of the reagent pad (74) contacts a larger pored surface of the HDL assay element (64).
 17. The device (14) of one of the preceding claims, wherein said reagent is immobilized to said reagent pad (74).
 18. The device (14) of claim 1, wherein said HDL assay element (64) comprises a biosensor.
 19. The device (14) of claim 18, wherein said biosensor (64) is effective to measure production of oxygen or hydrogen peroxide which is dependent on HDL-associated cholesterol concentration within said element (64).
 20. A method of measuring serum cholesterol associated with high-density lipoproteins (HDL) in a blood fluid sample also containing low density lipoproteins (LDL) or very low density lipoproteins (VLDL), comprising the following steps:

- a. applying said blood fluid sample to a sample distribution matrix (26);
- b. guiding said blood fluid sample through a reagent pad (74) containing a reagent effective to selectively remove non-HDL lipoproteins from the blood fluid sample; and
- c. determining the content of HDL lipoproteins in said blood fluid sample by a HDL assay element (64) in which HDL concentration can be assayed; wherein
- d. the fluid contact is selectively establishable between said sample distribution matrix (26) and said reagent pad (74) which is connected to said HDL assay element (64).
21. A method of measuring serum cholesterol associated with high-density lipoproteins (HDL) in a blood fluid sample also containing low density lipoproteins (LDL) or very low density lipoproteins (VLDL), comprising the following steps:
- a. contacting the sample with an absorptive sample distribution matrix (26) through which said sample is distributed to one or more sample collection sites (30, 32);
- b. bringing into contact with such a sample collection site (30, 32), a first surface of a reagent pad (74), to which said sample is transferred, containing a reagent effective to selectively remove non-HDL lipoproteins from the fluid sample, wherein an opposite surface of said reagent pad (74) is in simultaneous contact with an HDL assay element (64), in which HDL concentration can be assayed, such that successive sample volumes proceed from said reagent pad (74) to said HDL assay element (64), and
- c. determining the level of HDL cholesterol in said sample by optical detection at said HDL assay element (64).
22. The method of claim 20 or 21, further comprising the step of breaking said contact between the sample distribution matrix (26) and said reagent pad (74), when a desired amount of sample has been transferred.
23. The method of claim 22, wherein said reagent pad (74) comprises an asymmetric polymeric membrane, having a smaller pored surface and an opposite, larger pored surface.
24. The method of claim 23, wherein said membrane is oriented such that its smaller pored surface faces said HDL assay element (64).
25. The method of claim 24, wherein said HDL assay element (64) is an asymmetric polymeric membrane, having a smaller pored surface and an opposite, larger pored surface.
26. The method of claim 25, wherein said membrane is oriented such that its larger pored surface faces said reagent pad (74).
27. The method of claim 26, wherein each of said HDL assay element (64) and said reagent pad (74) is an asymmetric polymeric membrane, and said membranes are laminated such that the smaller pored surface of the reagent pad contacts a larger pored surface of the HDL assay element (64).
28. The method of claim 20 or 21, wherein said reagent effective to selectively remove non-HDL lipoproteins is immobilized to said reagent pad (74).
29. The method of claim 20 or 21, wherein said HDL assay element (64) comprises a biosensor.
30. The method of claim 29, wherein said biosensor (64) is effective to measure production of oxygen or hydrogen peroxide which is dependent on HDL-associated cholesterol concentration within said element (64).

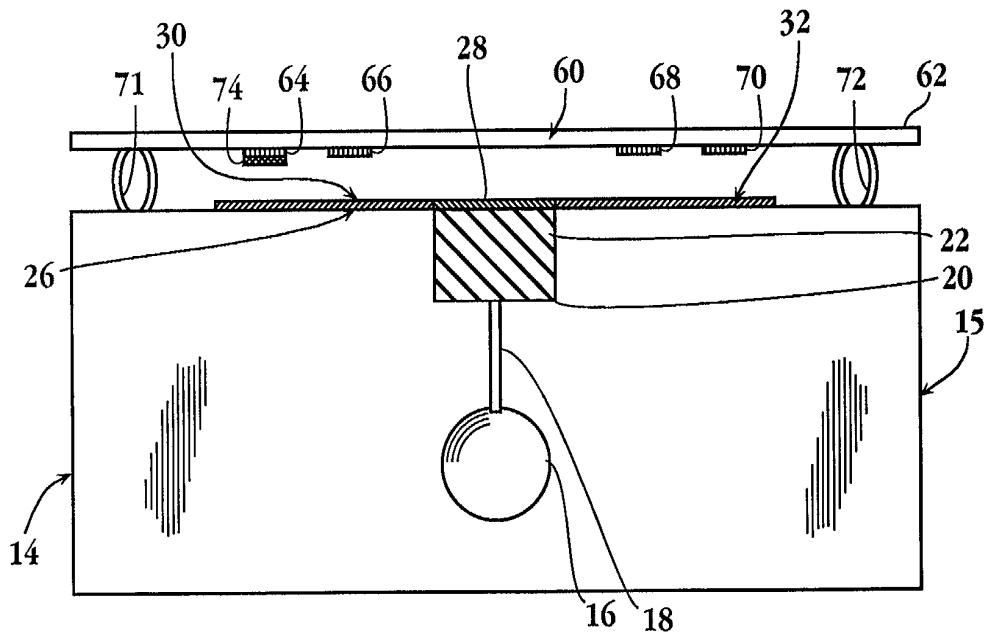

Fig. 1

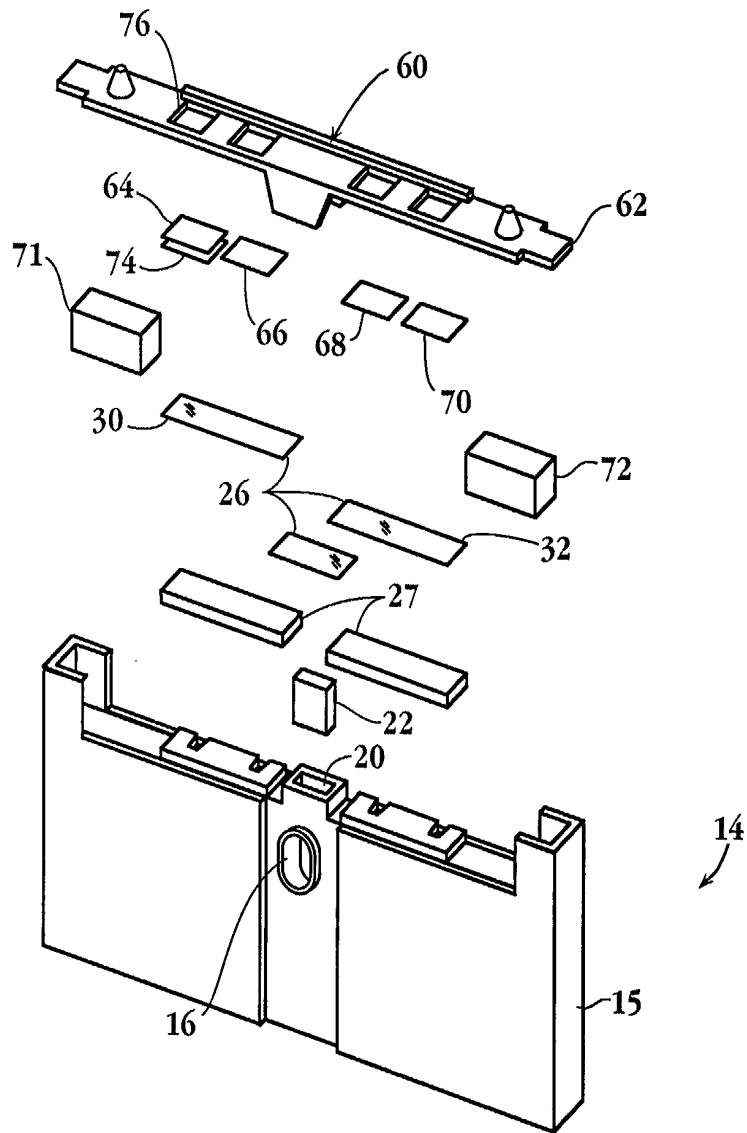

Fig. 2

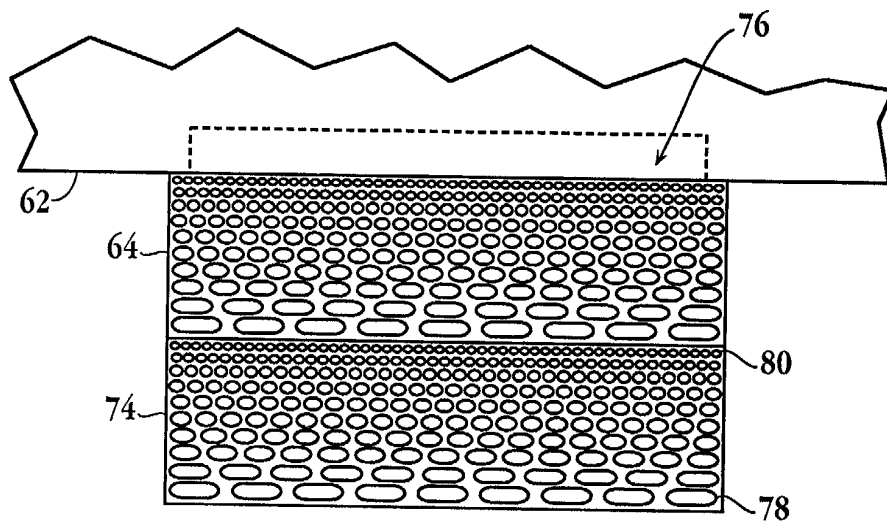

Fig. 3

专利名称(译)	高密度脂蛋白测定装置和方法		
公开(公告)号	EP1329724A2	公开(公告)日	2003-07-23
申请号	EP2002004339	申请日	2002-03-01
申请(专利权)人(译)	CHOLESTECH CORPORATION		
当前申请(专利权)人(译)	CHOLESTECH CORPORATION		
[标]发明人	JONES RONALD M WORTHY THOMAS E NUGENT ANTONY		
发明人	JONES, RONALD M. WORTHY, THOMAS E. NUGENT, ANTONY		
IPC分类号	G01N33/48 G01N33/50 G01N33/53 G01N33/543 G01N33/558 G01N33/92		
CPC分类号	G01N33/5302 G01N33/54366 G01N33/558 G01N33/92 G01N2800/044 Y10T436/25125 Y10T436/25375 Y10T436/255		
优先权	60/349926 2002-01-18 US		
其他公开文献	EP1329724A3 EP1329724B1		
外部链接	Espacenet		

摘要(译)

描述了用于测量血液样品中HDL相关胆固醇浓度的测定装置和方法。该装置允许在受控量的单个样品上同时进行多次测定，同时通过沉淀试剂使样品污染的风险最小化。

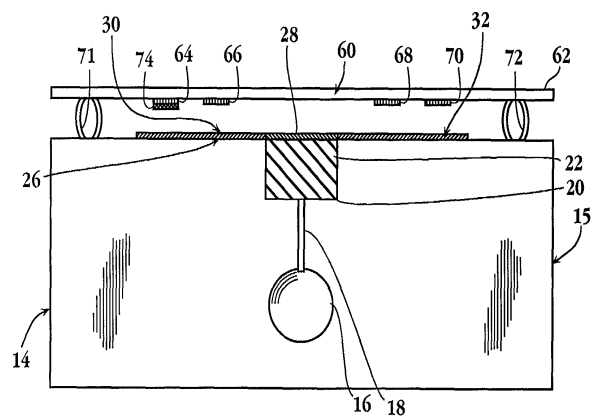

Fig. 1