



(51) International Patent Classification:

G01N 21/01 (2006.01) G01N 33/53 (2006.01)
G01N 33/52 (2006.01) B01L 3/00 (2006.01)

(21) International Application Number:

PCT/FI2013/000006

(22) International Filing Date:

1 February 2013 (01.02.2013)

(25) Filing Language:

English

(26) Publication Language:

English

(30) Priority Data:

20120036 3 February 2012 (03.02.2012) FI

(72) Inventor; and

(71) Applicant : KORPELA, Timo Kalevi [FI/FI];
Kraatarinkatu 1 D 42, FI-20610 Turku (FI).

(81) Designated States (unless otherwise indicated, for every kind of national protection available): AE, AG, AL, AM, AO, AT, AU, AZ, BA, BB, BG, BH, BN, BR, BW, BY, BZ, CA, CH, CL, CN, CO, CR, CU, CZ, DE, DK, DM,

DO, DZ, EC, EE, EG, ES, FI, GB, GD, GE, GH, GM, GT, HN, HR, HU, ID, IL, IN, IS, JP, KE, KG, KM, KN, KP, KR, KZ, LA, LC, LK, LR, LS, LT, LU, LY, MA, MD, ME, MG, MK, MN, MW, MX, MY, MZ, NA, NG, NI, NO, NZ, OM, PA, PE, PG, PH, PL, PT, QA, RO, RS, RU, RW, SC, SD, SE, SG, SK, SL, SM, ST, SV, SY, TH, TJ, TM, TN, TR, TT, TZ, UA, UG, US, UZ, VC, VN, ZA, ZM, ZW.

(84) Designated States (unless otherwise indicated, for every kind of regional protection available): ARIPO (BW, GH, GM, KE, LR, LS, MW, MZ, NA, RW, SD, SL, SZ, TZ, UG, ZM, ZW), Eurasian (AM, AZ, BY, KG, KZ, RU, TJ, TM), European (AL, AT, BE, BG, CH, CY, CZ, DE, DK, EE, ES, FI, FR, GB, GR, HR, HU, IE, IS, IT, LT, LU, LV, MC, MK, MT, NL, NO, PL, PT, RO, RS, SE, SI, SK, SM, TR), OAPI (BF, BJ, CF, CG, CI, CM, GA, GN, GQ, GW, ML, MR, NE, SN, TD, TG).

Published:

— with international search report (Art. 21(3))

(54) Title: MECHANICAL WASHING AND MEASURING DEVICE FOR PERFORMING ANALYSES

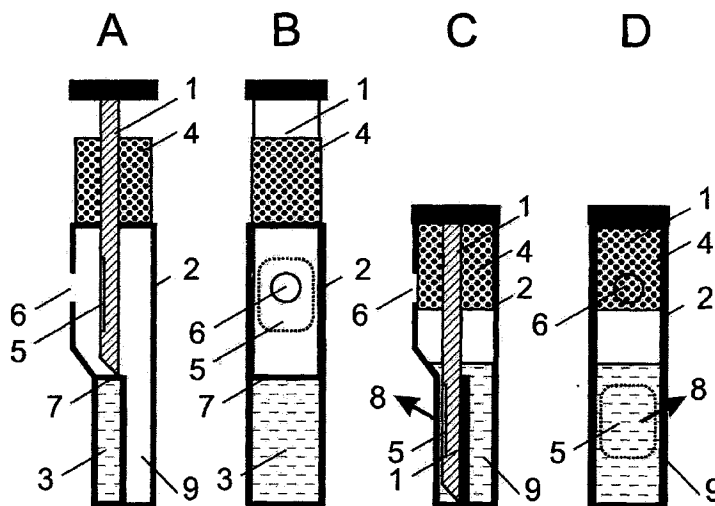

Figure 1 (A-D)

(57) Abstract: The invention describes simple and reliable cartridge constructions for carrying out analytical procedures in a closed system, especially for carrying out bioaffinity analyses. The cartridge exploits a measuring component, or a test strip (1 in Fig 1) and its cover (2 in Fig 1) as well as the motion between these two components to achieve liquid flow and events which are necessary for the analysis.

WO 2013/113983 A1

MECHANICAL WASHING AND MEASURING DEVICE FOR PERFORMING ANALYSES

5

FIELD OF INVENTION

10 The invention is focused to deal with a mechanical device, which performs analyses in a chamber which enables washing and measuring steps to be done so that liquid is not added or removed from the chamber. The described invention can be exploited as a single-use analytical device especially in hospital laboratories and doctors' offices.

15 BACKGROUND OF THE INVENTION

When diagnosing human and animal diseases, as well as, performing various other analytical tasks in laboratories, each individual analysis is often attempted to be done in a separate closed measuring cell (chamber, cassette, or cartridge are also used as the synonyms). This will reduce the contamination risk between different samples (e.g. DNA analyses) and increase the safety of the personnel (microbiological samples, poisons).

20 Measuring cell is defined as a relatively small device to which the sample to be analyzed will be introduced. After the sample, various processes are made which effect movements of reacting components and liquids by employing pumps from outside or inside of the cell; or capillary, centrifugal, electrical, or magnetic forces are exploited. After these procedures, the measurement itself can take place inside or from outside of the cell. The measuring cell should be small and the measuring procedure must be reproducible even the samples are from different sources and therefore having different properties. For example, different human individuals may have body fluids which differ in viscosity or capillary properties and this can harm or prevent getting reproducible results. The drawback of applying outside pumps (suction or pressure) lies in their complexity since the pump must be mechanically joined to the measuring cell. Contamination risks may also appear at this stage. The drawback of internal micro pumps is their high price and poor reliability. When using small channels in transferring liquids, viscosity and capillary forces always interfere even if the liquid movement is forced by pumps or centrifugal forces.

35 Several projects are globally underway targeting to analyses made in closed cassettes or cells including liquids and reagents stored inside the cell ("all-in-one" cassette). Such projects are usually based on applying microfluidistic technologies. The gathered experience, however, shows that microfluidistic devices are very difficult to produce industrially so that they equally from cell to cell and especially from batch to batch of then devices. Very small channels in the devices bring drawbacks which origin from qualitatively different laws of micro/nano world compared to the usual macro world. The phenomena are difficult to control because they are result from many parameters

40
45

including surface tension, capillary forces, viscosity, osmotic pressure, electrolyte composition, temperature and/or material surface changes. The colligative properties of liquids always deviate from ideal solutions, especially in the case of complex biological samples.

The analytical tests which especially benefit from closed measuring cells are those dealing with substances which cause big risks for infection, for example, when dealing with blood samples from patients carrying potentially dangerous microbes or viruses. In such cases, no material must not escape from the measuring cell. Biological and chemical toxins belong to the same category. The methods based on nucleic acids recognition are extremely interference-sensitive and even micro or nano droplets can contaminate the laboratory and hence cause occasional false results for a long future time. To overcome the problems necessitate performing of a profound cleaning process in the laboratory. The diagnostic tests made at doctors' offices (so-called point-of-care, POC) do not necessarily belong to very dangerous ones, but thereby the use of measuring cells can make the performance of the analyses simple and uneducated technical assistants can do the test. The small size of the measuring cell used in POC need not to be advantageous because the cell must be convenient to be manipulated. According to the present invention, the small size of the measuring cell is not the special objective but to have a handy device which can be easily manipulated. Therefore, the drawbacks originating from micro and nano structures can be in a great extent avoided by the present invention.

The closest inventions to the present one could be illustrated by the following patent publications. US 2005186111A1 (2005, Wang Naishu et al) describes an interrupted immunological testing device. WO 2011003281 A1 (2011, Alere Switzerland GMBH) describes a construction of detection device having two vessels which can be mechanically inserted to each other. US 2003180815 A1 (2003, Rawson Keith et al.) describes a lateral flow test strip and a reagent storage blister. Constructions in US 5744096 A (1998; Jones Rold et al.) and US 2011290669 A1 (2011, Davis Graham et al.) applied movable components to carry out immunoassays. The drawback in all these five related inventions is that they are technically very demanding to manufacture and therefore the advantages over the existing micro-fluidistic measuring cells remain marginal. In addition, the cited patent publications do not describe all the essential technical features of the present invention.

The before-described problems of washing, measurement, and contamination can be avoided, according to the present invention, by a closed single-use measuring cell, which does not contain microchannels and which is made enough large in size to be easily manipulated. The invention exploits a simple, easily fabricable mechanical pump for moving liquids. The pump itself serves as an active part of performing the analysis. The pump contains two parts, which can be described as a "cylinder" and a "piston". The pumping effect is achieved by pressing the piston into a liquid reservoir inside the cylinder part. This process includes events which are required to fulfill the analysis. The

process leads to obtaining of analytically meaningful results. The typical features of the invention are further described in the patent claims.

5

BRIEF DESCRIPTION OF FIGURES

- 10 **Figure 1.** Fig. A is the front-view of the measuring cell before analysis. Fig. B shows the side-view. Fig. C (front view) shows the cell before the measurement (i.e. at the end of the movements) and Fig.D is the same from side. The terms of “up” and “down” are used thereafter only for clarity reasons assuming that the device stands as drawn in the Figs. The numbering is as follows: 1, the part of the measuring cell (test strip) which functions like a piston. It can be plunged into the vessel 2 (i.e. the container for 1, cartridge casing or “cylinder”) down to liquid container, blister, or reservoir (3). Leakage of liquid from (2) is prevented with liquid-absorbing material (4) which moves together with the cover of (2) down inside of (2) when (1) is pressed down. The piston (1) contains active surface (5) necessary to the analytical procedures. The sample is inserted onto (5) through a hole or slot (6) of (2). The reservoir (3) can contain one or more of liquid compartments preferably separated with a film which can be broken when the piston (1) is pressed forward (usually down). The tip of the lower part of (1) is shaped in such a way that when the piston is pushed down, the protruding liquid is directed to wash the active surface (5). In the measurement position (C and D), the analytically active surface (5) locates in front of the sample window allowing light detection through the window. The side of the piston (1) moves in a respective groove in the cylinder (2) which guides smooth and accurate movement of (2; not shown in Figs). When the piston is at the down position (measurement position) and extension on the piston (just above the active surface, not drawn in the Figs for clarity) will lock the liquid reservoir. The Figures do not define the sizes and exact relations of the measures of the components. They can be altered according to the applications and methods of measurement. The drain holes above and/or sides of the active surface (5) are not also shown in Fig.1 for clarity. In Fig 1, C and D, the arrow 8 describes the light generated from the measuring step, for example, luminescence after excitation of luminophoric label molecules. In Fig. 1, A and D, part 9 illustrates the space where the washing liquid can be introduced (illustrated in Fig 3 by arrows). Reservoir 9 may contain a liquid absorbing material. In Fig A, the used washing liquid can also locate in the space in the chamber above the active surface or the liquid can be absorbed into material (4), and thereby (2) can be realized more simply.
- 15
20
25
30
35
- 40 **Figure 2.** Measuring cell made of two cylinders inserted one inside the other. The measuring cell functions as in Fig. 1. In Fig 2 A, the cell is up and ready for sample application. Fig. 2 B illustrates the cell ready for the measurement. In the Fig 2, the active surface (5) can be around the whole cylinder. The active surface is preferably in a niche of the piston and then the surface will not be prone to mechanical scratches from movements of the inserted tubes. The sample is applied through hole (6) to the active
- 45

surface (5). The hole is covered with a stopper which is taken off when the sample is applied. This construction allows penetration of the sample by capillary forces over the space between the two cylinders. The distance between piston and cylinder is optimally 0.1-2.5 mm. Extra sample is leaking through holes (9) into the inner cylinder (serving as the waste storage). The inner cylinder is closed in down part but the upper part has a small hole for air (8) and a porous absorbing stopper which prevents liquid to spill off if the cell is turned upside down. In Fig. 2 the liquid reservoir (3) is tightened between the inserted cylinders with a waxy substance at the down part of piston (1) at position (7). When the piston (1) is pushed down, the liquid in reservoir 3 flows up through the space between the cylinders and leaks through holes (9) into the waste storage inside the inner tube and simultaneously rinses the surface (5). When the piston is down, the measurement is carried out.

Figure 3. Fig. 3 A (the cross-section is rectangular as in Fig. 1) describes the starting position as in Fig. 1 from side. In Fig. B, the piston is being pressed down so that the liquid from reservoir (3) flows through a thin channel in such a way that it effectively rinses the analytical surface (5). Fig. 3 exemplifies a construction of a liquid-proof tightening of the down tip of piston. This can be achieved by an distal extension of the piston and tightening material like rubber or plastic with a fit snug. The down part of the piston fits exactly against the outer wall deviating in this respect from constructions in Figs 1 and 2. In Fig. 3 B, the pathway of the liquid from storage reservoir (3) to waste reservoir (8) is illustrated with arrows. For the liquid flow, the piston has hole (9). The very initial movement of the piston is allowed by either a small amount of air in the storage reservoir (3) or a flexible bellows in the liquid. For clarity, Fig. 3 does not show the liquid absorbing material as in Fig. 1.

30

DETAILED DESCRIPTION OF THE INVENTION

The invention describes a measuring cell (chamber, cassette, or cartridge) which can be used for performing an analysis in a sealed chamber. The cell consists of two parts, outer (cover, cylinder part, cartridge casing) and inner parts (piston or test chip, or test strip). The piston can be pushed inside the cylinder in such way that cylinder and piston form an integral unity which does not leak liquid outside. When the piston is at the down position the system can be subjected to a measuring process. Such a measuring cell can be also stored for a later measurement or to be sent elsewhere to be measured. Figures 1-3 illustrate three different ways of realizing the same principle. The Figures describe only the principles of realization and do not consider the exact or relative measures of the acting parts. An essential feature of the present invention is a piston and a cylinder, relative movements of which are exploited for achieving the desired measurement process.

45

The piston part or inner part is related to normal test strips commonly used for performing rapid tests. For example, sugar analyses of urine or pregnancy tests often use a plastic strip furnished with structures which contain the needed reagents and label compounds allowing to estimate the amount of the analyte in sample by a color change.

Analyses requiring high accuracy and reproducibility are often made on the surface of a plastic plate with the principle of bioaffinity. The plastic is coated with antibodies or other biomolecules, like DNA probes, which can selectively bind the analytes. In the present invention, such a surface is called as analytically active surface or active surface. It is often created on a surface of a vessel, like a microtiter plate wells. The sample and needed reagents are brought into the vessel and the reaction is allowed to complete followed by washing the unused reagents away.

The next reactions and measurement can be carried out in the same vessel with proper solutions. An example for such a test concept is the DELFIA technology of PerkinElmer-Wallac (PerkinElmer Finland Co., Turku, Finland) employing luminescent label molecules excited with light pulses. The luminescent labels can also be excited with electrical pulses as illustrated with the CECL-technique (Cathodic Electro Chemi Luminescence, www.Labmaster.fi). Commonly used ELISA method is based the use of enzymes for the multiplication of the measurable signal. Often produced color is measured photometrically. In all these techniques vessels and test strips are prone to contaminations in the measuring conditions. The measuring includes many steps and more than one technical device in addition to the measuring instrument (e.g. photometer, fluorometer, luminometer).

Devices containing various complex capillary and micro technical details have been developed for carrying out the above-described analyses. Their drawback is the very demanding production technology and the false results originating from the tiny dimensions.

It was found in the present invention that the objective of applying micro and nano technical details is not sensible in majority of cases and simple closed contamination-free measuring cells can be elaborated to solve complicated analytical problems. In the present invention, the traditional role of the measuring vessel and the analytically active surface has been interchanged. The passive parts, which are used in the common test chip to make the manipulation easier, are employed in the present invention to carry out processes needed for the analysis: the test chips are used for moving liquids in addition to chips' normal use.

The cover part (chassis) of the test chip (2 in Figs 1-3), or outer part of the cell, is equally well employed as an active part. Instead of special expensive and complex washing systems, the present invention exploits the mechanical movement between the test chip (1, in Figs 1-3) and its cover (2, in Figs 1-3) to provide the washing. A resulting thin liquid, preferably of turbulent rather than laminar, flow obtained by the movement of (1)

and (2) makes it possible to achieve very effective washing of a surface and/or to use only tiny liquid volumes. When using small liquid volumes for washing, considerably savings in reagent costs will be achieved.

5

According to the present invention the "piston" (1) is composed of a flat or cylindrical component (test chip, strip) containing the analytically active area (5). This area may have been prepared by introducing, for example, antibody or DNA probe onto a plastic strip by adsorption or by covalent coating. The details of preparation of the active area depend on the physico-chemical method by which the measurement itself is realized. For example, a plastic plate or related material is covered with a drop of antibody solution and antibody is allowed to attach to the surface. Unbound antibody is then washed off after a certain time. Depending on the assay principle also other reagents can be brought onto the surface. So-called sandwich assay exploits, in addition, another type of monoclonal (secondary) antibody which is labeled with a luminescent compound or an enzyme. These labeled secondary antibodies can be brought onto the surface also after the sample or as mixed with the sample. If the label substances are excited with light, no other special part in the measuring cell is required. If the label is excited by electricity (anodic or cathodic pulses), the test strip must contain also anode and cathode and their wiring to the excitation electronics.

10
15
20

The analytically active surface (5, in Figs 1-3) can be covered by a filter material which removes particles from the sample and/or introduces the sample smoothly onto the surface. If removal of the filter is required, the present invention teaches to direct the liquid flow in such a way that it will push the filter away from the surface and allow the active surface to be free during the excitation and light measurement.

25

The sample to be analyzed is placed onto the analytically active surface (containing a filter or not). The test strip is placed inside the cell so that the sample can be introduced through a small hole in the cell (6 in Fig. 1). The hole is preferably opened only for the period of application; otherwise it is closed with an adhesive tape or stopper. After the application of the sample, a predetermined time will be waited to allow reaction to take place. After that, the piston is pushed downwards so that piston will replace liquid in the reservoir and concomitantly push the liquid primarily over the analytically active surface thereby washing the surface. The washing liquid is constantly fresh as opposite to the usual batch washing. Since the moving liquid layer is relatively small (0.1-2.5 mm), the axial diffusion velocity of the sample component is negligible compared to horizontal diffusion of the reacting components.

30
35

The efficiency of the washing can be adjusted by adjusting the thickness of the liquid layer and/or changing the axial velocity of the piston. The increase of the velocity of the piston changes the liquid flow from laminar to turbulent. Typical specific feature of the invention is the extremely efficient controllable washing of the active surface that is significantly better than with the mode of batch washing. The batch washing means that a certain amount of liquid is injected and sucked away several times. With batch washing

40
45

the consumption of washing liquid is significantly higher as regards to washing result than with the method of the present invention.

- 5 The piston can be pushed manually but it is also feasible to construct an electrical motor-driven instrument and to include timing automatics in it. All this can be included in the measuring instrument.

10 When the piston reaches its lowest position, the measurement can be in many cases done immediately. In the case of luminescence or absorbance, the measuring cell must contain proper windows transmitting the required wavelengths of light. It may be advantageous to make the whole outer part (i.e. cover or chassis, 2) of the cell of transparent material like polystyrene. The window material of the chassis can also be dyed which can serve as filter for the light. The efficiency of the light detection can be improved with reflectors and mirrors inside the measuring cell and/or instrument's measuring chamber. In a
15 cylindrical construction, illustrated in Fig. 2, analytically active part can be the whole ring (band) around the cylinder. This is not any hindrance since the generated light can be readily guided to a light sensor (e.g. photomultiplier) with reflectors. For radioactive labels, annular detectors can be used.

20 When the invention is applied to ELISA or related tests, wherein the label is an enzyme, the liquid reservoir can involve two or more of compartments. The first chamber can contain a washing liquid while the next contains the substrate solution of the enzyme. The compartments can be separated with a breach-able membrane, for example.

25 Figures 1-3 indicate the mode of realization of the invention when the analytically active surface is of plane form. The surface can also include grooves, papillae, bars etc., which increase the effective surface area. Especially with ELISA tests using absorbance measurement, it may be advantageous to use a cylindrical (or any other form) hole (or
30 holes) as the source the active surface. For example in Fig. 1 A, it could have been bored horizontally, partly or totally, through the test strip (piston). In such a construction the piston can fit rather exactly into the liquid reservoir. The washing liquid and substrate solution flow is arranged through the horizontal chamber with the aid of vertically bored hole(s) in the piston to the waste reservoir. At the end of the process, the horizontal
35 chamber is full of substrate solution of the enzyme. The enzyme activity (proportional to the amount of the analyte) is measured through the chamber with the generated color intensity after a suitable time interval.

40 An essential feature of the present invention is that the construction of the cell is simple and integral. Its manipulations are safe to the user even with dangerous samples, like body fluids of diseased people. Furthermore, the measuring cell tolerates different storage conditions. The devices are preferably packed into sealed individual packages. The hole for the sample application is closed and is opened only for the application of the sample. To prevent any kind of leakages from the cell, it is preferably further supplied with a
45 liquid absorbing material, like soft plastic, polyethylene glycol, or cotton. When the

upper end of the liquid reservoir closes the space of the analytically active area (not drawn in Figs 1-3 for clarity) while the cap of the piston closes the whole cell. The measuring cell can be stored for longer periods of time without significant changes in the properties even when it contains the analytical samples.

Figure 1 illustrates a construction wherein the liquid storage is closed with a thin membrane (drawn also in Fig.4) which is broken by the down-movement of the piston. Figure 2 illustrates a construction wherein the respective point is circularly tightened with a waxy substance which decomposes by the movement of the piston. In Fig. 3, the tip of the piston is snugly fitted into the chamber which closes the channels for liquids.

A large variety of materials can be chosen to make the measuring cells. The choice depends on the specific applications and on the detection technology. In general polystyrene and other transparent plastics are preferable. The technologies which suit to manufacturing of the measuring cells from plastic are injection molding and casting.

As implied above, the measuring cell of the present invention is adaptable to many kinds of analyses and measuring techniques. The invention is further described below with non-limiting examples. The examples illustrate a detection technology using electrical excitation of luminescent label molecules on a routine test strip of the technology (www.Labmaster.fi) and ELISA method using a polystyrene strip as the piston. Both examples exploited a separately fabricated cover part (chamber).

EXAMPLE 1

A piece of doped 1-mm silicon (4x9 mm) was mounted into a polystyrene plate of about 3 mm thickness (length 5 cm, width 1.2 cm). The silicon piece was oxidized to make resistor film of 4 nm thickness on it (www.Labmaster.fi). The test strip was biochemically prepared in such a way that it can analyze C-reactive protein (CRP) from human blood. The silicon piece was covered with a filter membrane including dried secondary antibody labeled with a terbium chelate. The test strip was equipped with electrical contact to cathode with an adhesive copper film while anode was a stainless steel spike pushed through the bottom of the liquid reservoir (device as in Fig 1).

The liquid reservoir contained 1 ml of standard electrolyte solution which served as washing as measuring buffer. The first prototypes were prepared by using commercially available cuvettes for spectrophotometry which were essentially like the cover part of the cells described in Fig. 1. Hole was bored in the wall of the cover part (as 6 in Fig.1). The tip of the test strip was machined diagonal (45 degree) as in Fig 1 to optimize the liquid flow to focus onto the silicon surface. The gap between the cylinder and piston at the place of analytically active area was 1.5 mm and at the opposite site of the piston 0.1 mm. The piston was pressed manually simultaneously observing the liquid flow. When the flow reached the membrane above the silicon piece, membrane was detached and was directed upwards with the liquid flow. The piston was pressed down and the

mode (Labmaster Ltd., Turku, Finland). When measuring unknown patient samples and CRP standard solutions, similar results were obtained within experimental errors as those obtained when the test strip were extensively washed batchwisely.

EXAMPLE 2

The experiment of Example 1 was made with a test strip wherein anode and cathode were integrated onto same level on the plastic strip. From both of the poles electrical contacts were made onto the top of the (piston) strip. The function and results of the experiment were similar to those of Example 1.

EXAMPLE 3

The function of device with construction of Fig. 2 was tested with the ELISA method. The analytically active circular surface was coated with CRP-catching antibodies, washed and saturated with albumin solution with standard methods in literature. A sample and a secondary antibody labeled with alkaline phosphatase were mixed and were pipetted onto the active area through hole 6 (Fig.2) so that the liquid started to spill over through holes 9. After 20 min the piston was pushed down during 5 seconds into liquid 3 which was 1 ml of substrate solution of alkaline phosphatase. A part of the substrate served as the washing liquid. After 15 min, the generated yellow color was measured with absorption photometry directly through the plastic tubes. Since the optical thickness in this construction was only about 2 mm, and the width of the light beam was narrow, this method was poor in sensitivity. These drawbacks can be avoided with proper arrangements which a person skilled in the art can make. Therefore, the constructions of the present invention are useful also for ELISA measurements.

EXAMPLE 4

Figure 3 illustrates a construction which employs tight fitting between cylinder (cover part) and piston (test strip) at the tip of the strip. The construction in Fig 3 is not symmetrical but the piston situates in the front part of the cover. A thin rectangular channel exists in front of the strip piston which is in contact to the liquid reservoir from down. When the piston is down (in measuring stage), a thin layer of liquid in front of measuring window does not interfere the results, especially if the liquid is colorless. The construction of Fig. 3 showed good washing properties.

CLAIMS

5

1. A construction of a measuring cell for carrying out chemical and biochemical analyses, the construction composed of two movable parts wherein:

10

i) the measuring cell contains two parts (1 and 2; in Figures 1-2) which can move in respect to each other so that the inner part (1), or piston, can move inside the outer part, or cylinder, (2) from the initial preparedness position (A,B) to measuring position (C,D),

15

ii) the inner part (1, in Figs 1-3) is solid material and contains components in dry stage needed to carry out the analytical procedure,

20

iii) the outer part (2, in Figs 1-3) has a liquid reservoir (3, in Figs 1-3) which contains liquid needed to perform the analytical process,

25

iv) the inner part (1, in Figs 1-3) contains the active surface (5, in Figs 1-3) and in the initial preparedness stage (A,B, in Figs 1-2) a sample to be analyzed can be introduced through the hole (6 in Figs 1-2) onto the active surface (5 in Fig 1-3),

30

v) when the device is changed from stage A,B (Figs 1-2) to stage C,D (Figs 1-2), the tip of the inner part (7 in Figs 1-2) protrudes into liquid reservoir (3 in Figs 1-3) while the liquid in the reservoir erupts off onto the active surface (5 in Figs 1-3) and is washing it,

35

vi) the liquid erupting from the liquid reservoir (3 in Figs 1-3) over the active surface (5 in Figs 1-3) flows through the holes (9 in Figs 2-3) into waste reservoir (9 in Fig 1) or is absorbed into a porous material (4 in Fig 1) around the active surface,

40

vii) the analytes bound to the active surface (5 in Figs 1-3) are measured through the outer part (2, Figs 1-3) of the cell,

45

viii) optionally, the change of the inner part (1) from stage A,B to C,D (Figs 1-2) is carried out by movement of the piston (1) through more than one liquid chambers of the liquid reservoir (3 in Figs 1-3), the reservoir being separated with mixing barriers separating different solutions from each other, and the different solutions interact with the active surface (5, in Figs 1-3) in the order of penetration of the piston (1, in Figs 1-3) through the chambers.

- 5 2. The measuring cell according to Claim 1 wherein the sample to be analyzed is of biological origin.
- 10 3. The measuring cells according to Claim 1 wherein the active surface (5 in Figs 1-3) is coated with specific materials to carry out an immuno or a nucleic acid bioaffinity reaction.
- 15 4. The measuring cell according to Claim 1 wherein the measurement is carried out with electrical excitation of label molecules and the analysis results are expressed as the luminescence intensity.
- 20 5. The measuring cell according to Claim 1 wherein the measurement is carried out by using electromagnetic radiation.
6. The measuring cell according to Claim 1 wherein an enzyme reaction is exploited in expressing the amount of an analyte in the sample.
- 25 7. The measuring cell according to Claim 1 wherein radioactive label components are measured.
- 30 8. Construction of an analytical measuring cell involving two moving parts according to Claim 1, wherein the piston-like inner part (1 in Figs 1-3) can be mechanically moved inside the outer part (2 in Figs 1-3) of the cell in such a way that the liquid in the reservoir (3 in Figs 1-3) is transported by the action of the piston to a new reservoir of the measuring cell while the moving liquid flow rinses the active surface (5 in Figs 1-3).
- 35 9. Construction of an analytical measuring cell according to Claims 1 and 8 wherein the measuring cell contains liquid reservoir (3 in Figs 1-3) which is separated into more than one compartments to carry out at least washing, chemical or enzymatic reaction, and measurement steps while the piston involving an active surface (5) moves through the compartments and replaces liquid in the compartments of the reservoir.
- 40 10. Construction of an analytical measuring cell according to Claim 1 wherein the active surface (5 in Figs 1-3) is covered with a filter, which is removed by the eruption of liquid from liquid reservoir (3) generated by the movement of the inner part (1) into the outer part (2).
- 45

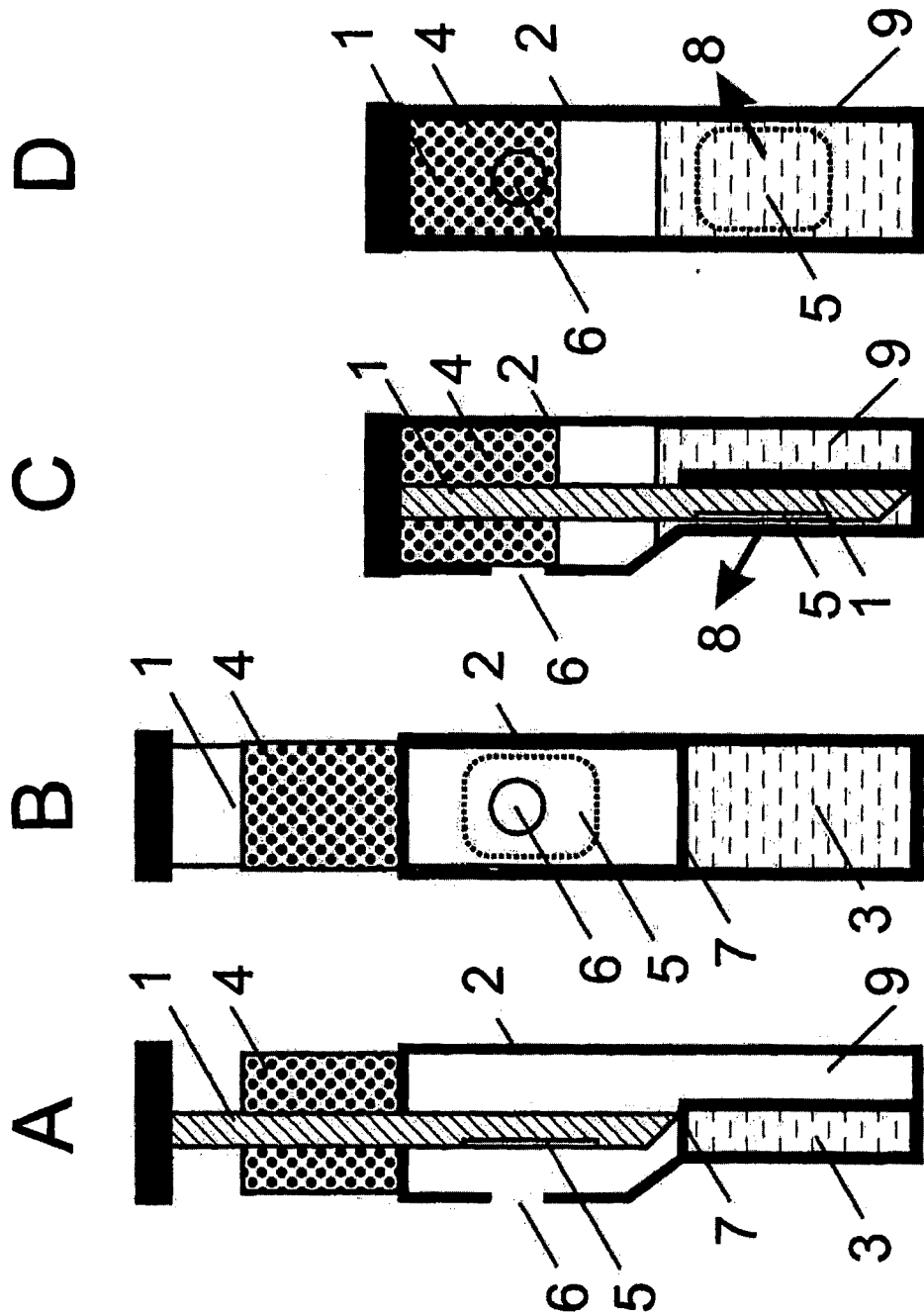

Figure 1 (A-D)

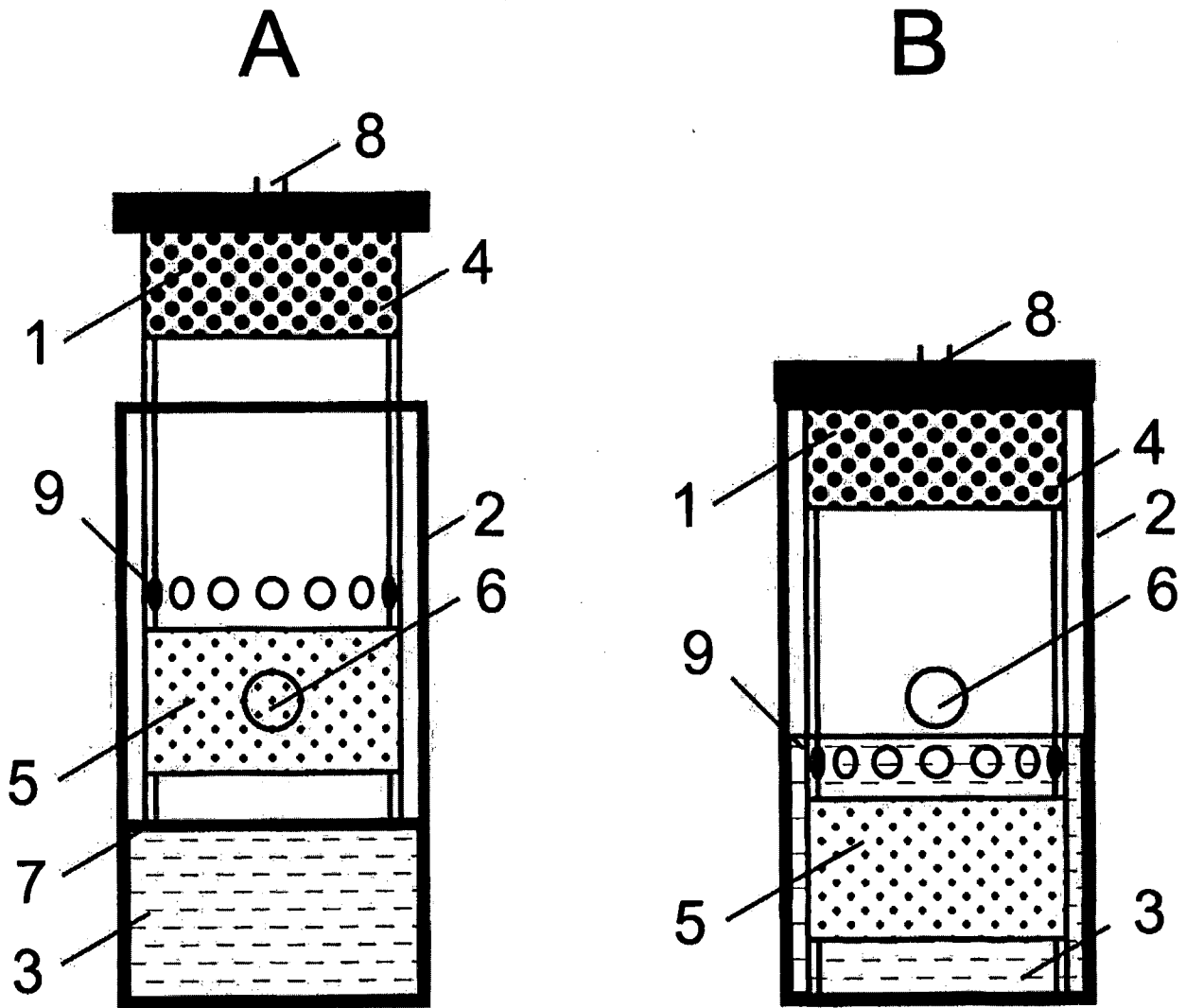

Figure 2 (A and B)

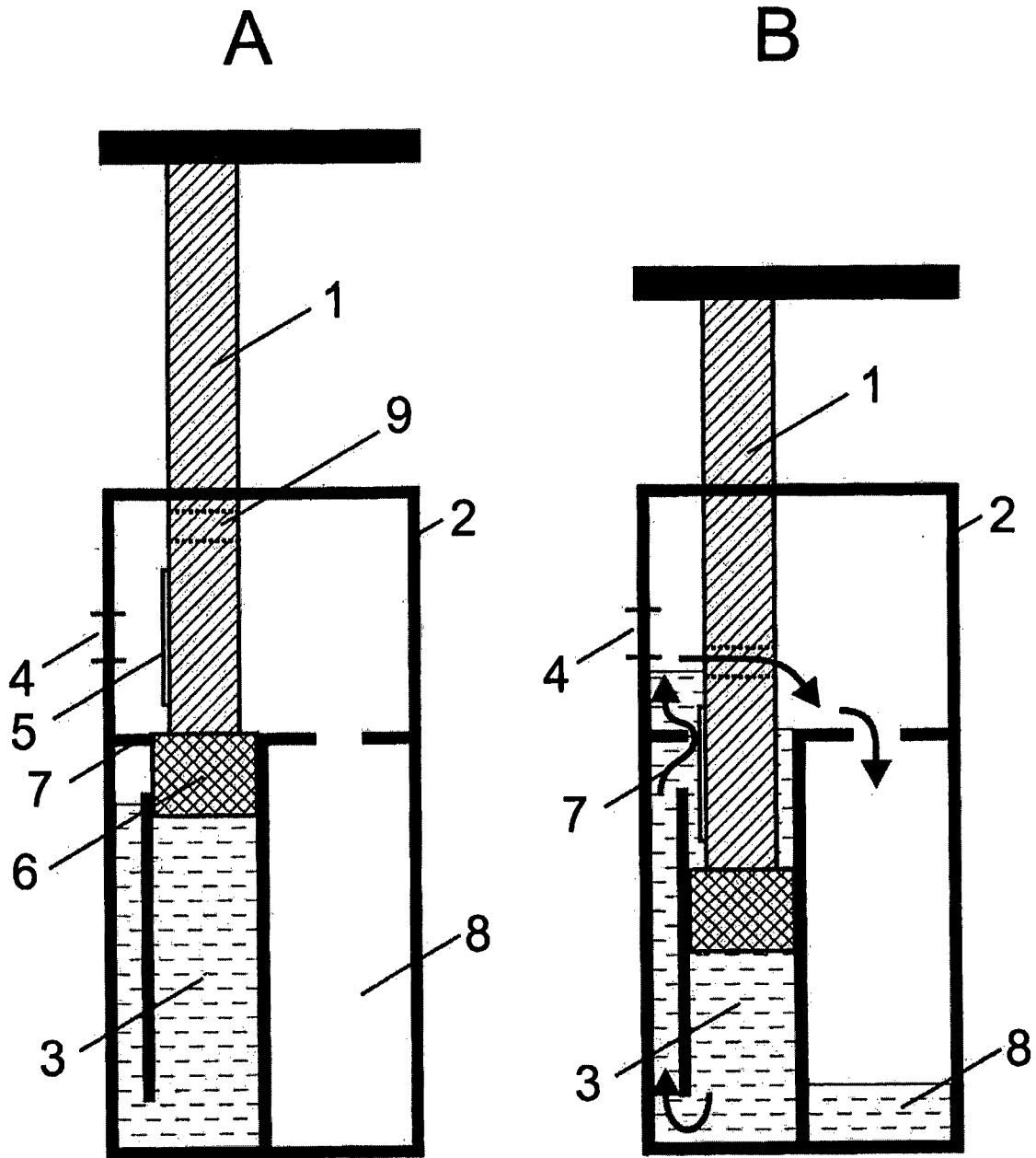

Figure 3 (A and B)

INTERNATIONAL SEARCH REPORT

International application No.

PCT/FI2013/000006

A. CLASSIFICATION OF SUBJECT MATTER

See extra sheet

According to International Patent Classification (IPC) or to both national classification and IPC

B. FIELDS SEARCHED

Minimum documentation searched (classification system followed by classification symbols)

IPC: G01N, B01L

Documentation searched other than minimum documentation to the extent that such documents are included in the fields searched

FI, SE, NO, DK

Electronic data base consulted during the international search (name of data base and, where practicable, search terms used)

EPO-Internal, WPI, INSPEC, XPESP, XPESP2, CAPLUS

C. DOCUMENTS CONSIDERED TO BE RELEVANT

Category*	Citation of document, with indication, where appropriate, of the relevant passages	Relevant to claim No.
A	WO 2011003281 A1 (ALERE SWITZERLAND GMBH [CH]) 13 January 2011 (13.01.2011) abstract; claims 1-7, 14, 27 and 28; page 22, second paragraph; Figures 1-3	1-10
A	EP 0378353 A2 (CANCER DIAGNOSTICS INC [US]) 18 July 1990 (18.07.1990) column 8, lines 2-13; Figures 13 and 14	1-10
A	WO 9706428 A1 (POOLE BRENT W [US]) 20 February 1997 (20.02.1997) claim 1	1-10

 Further documents are listed in the continuation of Box C.
 See patent family annex.

* Special categories of cited documents:

"A" document defining the general state of the art which is not considered to be of particular relevance

"E" earlier application or patent but published on or after the international filing date

"L" document which may throw doubts on priority claim(s) or which is cited to establish the publication date of another citation or other special reason (as specified)

"O" document referring to an oral disclosure, use, exhibition or other means

"P" document published prior to the international filing date but later than the priority date claimed

"T" later document published after the international filing date or priority date and not in conflict with the application but cited to understand the principle or theory underlying the invention

"X" document of particular relevance; the claimed invention cannot be considered novel or cannot be considered to involve an inventive step when the document is taken alone

"Y" document of particular relevance; the claimed invention cannot be considered to involve an inventive step when the document is combined with one or more other such documents, such combination being obvious to a person skilled in the art

"&" document member of the same patent family

Date of the actual completion of the international search

20 May 2013 (20.05.2013)

Date of mailing of the international search report

23 May 2013 (23.05.2013)

 Name and mailing address of the ISA/FI
 National Board of Patents and Registration of Finland
 P.O. Box 1160, FI-00101 HELSINKI, Finland

Facsimile No. +358 9 6939 5328

 Authorized officer
 Petra Vartiainen

Telephone No. +358 9 6939 500

INTERNATIONAL SEARCH REPORT
Information on patent family members

International application No.
PCT/FI2013/000006

Patent document cited in search report	Publication date	Patent family members(s)	Publication date
WO 2011003281 A1	13/01/2011	CN 101943696 A	12/01/2011
		CN 102012421 A	13/04/2011
		CN 201583537 U	15/09/2010
		CN 201654027 U	24/11/2010
		EP 2451576 A1	16/05/2012
		US 2012192628 A1	02/08/2012
.....			
EP 0378353 A2	18/07/1990	AT 119071 T	15/03/1995
		AT 158706 T	15/10/1997
		AT 159588 T	15/11/1997
		AT 253216 T	15/11/2003
		AT 258979 T	15/02/2004
		AU 630653 B2	05/11/1992
		AU 642884 B2	04/11/1993
		AU 642904 B2	04/11/1993
		AU 644096 B2	02/12/1993
		AU 645689 B2	20/01/1994
		AU 736841 B2	02/08/2001
		AU 755416 B2	12/12/2002
		AU 1778992 A	02/11/1992
		AU 1781492 A	17/11/1992
		AU 4777693 A	03/03/1994
		AU 4789590 A	19/07/1990
		AU 5767890 A	03/01/1991
		AU 6117490 A	28/02/1991
		AU 6252290 A	21/03/1991
		AU 6300690 A	28/03/1991
		AU 6316994 A	11/08/1994
		AU 8046791 A	23/01/1992
		AU 8245291 A	20/02/1992
		AU 8771498 A	01/03/1999
		AU 9117798 A	16/03/1999
		BR 9306818 A	08/12/1998
		BR 9811919 A	20/11/2001
		BR 9811919 B1	30/11/2010
		CA 1335787 C	06/06/1995
		CA 2025261 A1	23/03/1991
		CA 2046833 A1	19/01/1992
		CA 2049098 A1	16/02/1992
		CA 2084778 A1	09/10/1992
		CA 2085741 A1	19/10/1992
		CA 2085741 C	11/07/2000
		CA 2299629 A1	18/02/1999
CA 2299629 C	13/05/2008		
CA 2301551 A1	04/03/1999		
CA 2301551 C	30/10/2007		
CN 1277672 A	20/12/2000		
CN 1108518 C	14/05/2003		

INTERNATIONAL SEARCH REPORT
Information on patent family members

International application No.
PCT/FI2013/000006

Patent document cited in search report	Publication date	Patent family members(s)	Publication date
		CN 1271381 A	25/10/2000
		CN 1272426 C	30/08/2006
		DE 69017334 D1	06/04/1995
		DE 69017334 T2	29/06/1995
		DE 69031507 D1	06/11/1997
		DE 69031507 T2	19/03/1998
		DE 69222826 D1	27/11/1997
		DE 69222826 T2	19/02/1998
		DE 69331878 D1	06/06/2002
		DE 69331878 T2	12/12/2002
		DE 69819342 D1	04/12/2003
		DE 69819342 T2	29/07/2004
		DE 69821494 D1	11/03/2004
		DE 69821494 T2	16/09/2004
		DK 1003832 T3	10/05/2004
		DK 1007937 T3	15/03/2004
		EP 0378353 B1	01/10/1997
		EP 0404527 A2	27/12/1990
		EP 0414513 A2	27/02/1991
		EP 0419168 A2	27/03/1991
		EP 0419168 B1	01/03/1995
		EP 0425093 A2	02/05/1991
		EP 0468672 A1	29/01/1992
		EP 0471570 A1	19/02/1992
		EP 0533912 A1	31/03/1993
		EP 0535212 A1	07/04/1993
		EP 0535212 B1	22/10/1997
		EP 0654972 A1	31/05/1995
		EP 0654972 B1	02/05/2002
		EP 0654972 B8	18/09/2002
		EP 0737443 A2	16/10/1996
		EP 0787987 A2	06/08/1997
		EP 1003832 A1	31/05/2000
		EP 1003832 B1	04/02/2004
		EP 1007937 A1	14/06/2000
		EP 1007937 B1	29/10/2003
		ES 2072399 T3	16/07/1995
		IL 134404 D0	30/04/2001
		IL 134404 A	23/11/2003
		JP H03197864 A	29/08/1991
		JP 3012262 B2	21/02/2000
		JP H06500403 A	13/01/1994
		JP 3179785 B2	25/06/2001
		JP H06501101 A	27/01/1994
		JP 3244504 B2	07/01/2002
		JP H08508395 A	10/09/1996
		JP 3479300 B2	15/12/2003
		JP 2001512669 A	28/08/2001
		JP 3996736 B2	24/10/2007

INTERNATIONAL SEARCH REPORT
Information on patent family members

International application No.
PCT/FI2013/000006

Patent document cited in search report	Publication date	Patent family members(s)	Publication date
		JP 2001514383 A	11/09/2001
		JP 4024476 B2	19/12/2007
		JP H03128461 A	31/05/1991
		JP H03131760 A	05/06/1991
		JP H03170059 A	23/07/1991
		JP H03170060 A	23/07/1991
		JP H06308126 A	04/11/1994
		NZ 503084 A	27/07/2001
		US RE39457 E1	02/01/2007
		US 4953561 A	04/09/1990
		US 4960130 A	02/10/1990
		US 4961432 A	09/10/1990
		US 5003988 A	02/04/1991
		US 5016644 A	21/05/1991
		US 5022411 A	11/06/1991
		US 5024237 A	18/06/1991
		US 5024238 A	18/06/1991
		US 5038793 A	13/08/1991
		US 5042502 A	27/08/1991
		US 5077012 A	31/12/1991
		US 5133363 A	28/07/1992
		US 5137031 A	11/08/1992
		US 5139031 A	18/08/1992
		US 5224489 A	06/07/1993
		US 5301685 A	12/04/1994
		US 5358690 A	25/10/1994
		US 5429803 A	04/07/1995
		US 5471994 A	05/12/1995
		US 5849505 A	15/12/1998
		US 5998214 A	07/12/1999
		US 6106483 A	22/08/2000
		US 6149871 A	21/11/2000
		US 6210909 B1	03/04/2001
		US 6309362 B1	30/10/2001
		US 6423237 B1	23/07/2002
		US 6509164 B1	21/01/2003
		US 6589749 B1	08/07/2003
		WO 9217110 A1	15/10/1992
		WO 9218844 A1	29/10/1992
		WO 9403103 A1	17/02/1994
		WO 9907823 A1	18/02/1999
		WO 9910723 A1	04/03/1999
		ZA 9807007 A	15/02/2000
.....			
WO 9706428 A1	20/02/1997	AU 3323495 A	05/03/1997
.....			

CLASSIFICATION OF SUBJECT MATTER

Int.Cl.

G01N 21/01 (2006.01)

G01N 33/52 (2006.01)

G01N 33/53 (2006.01)

B01L 3/00 (2006.01)

专利名称(译)	用于执行分析的机械清洗和测量装置		
公开(公告)号	EP2810044A1	公开(公告)日	2014-12-10
申请号	EP2013742961	申请日	2013-02-01
[标]申请(专利权)人(译)	KORPELA TIMO卡莱维·		
申请(专利权)人(译)	KORPELA , TIMO卡莱维		
当前申请(专利权)人(译)	KORPELA , TIMO卡莱维		
[标]发明人	KORPELA TIMO KALEVI		
发明人	KORPELA, TIMO KALEVI		
IPC分类号	G01N21/01 G01N33/52 G01N33/53 B01L3/00 G01N21/03 G01N33/543		
CPC分类号	B01L3/502 B01L3/5023 B01L3/5082 B01L2300/044 B01L2300/0636 B01L2300/0867 B01L2300/087 B01L2400/0478 G01N33/54366 G01N2021/0325 G01N21/01 G01N33/52 G01N33/53		
优先权	2012000036 2012-02-03 FI		
其他公开文献	EP2810044A4		
外部链接	Espacenet		

摘要(译)

本发明描述了简单可靠的盒式结构，用于在封闭系统中进行分析程序，特别是用于进行生物亲和性分析。该盒利用测量部件或测试条（图1中的1）及其盖（图1中的2）以及这两个部件之间的运动以实现液体流动和分析所需的事件。