



(11) **EP 3 056 156 B1**

(12) **EUROPEAN PATENT SPECIFICATION**

(45) Date of publication and mention of the grant of the patent:  
**13.12.2017 Bulletin 2017/50**

(51) Int Cl.:  
**A61B 17/072<sup>(2006.01)</sup> A61B 17/32<sup>(2006.01)</sup>**

(21) Application number: **16154792.2**

(22) Date of filing: **09.02.2016**

---

(54) **SURGICAL STAPLING INSTRUMENT HAVING ULTRASONIC ENERGY DELIVERY**  
CHIRURGISCHES KLAMMERINSTRUMENT MIT ULTRASCHALLENERGIEVERABREICHUNG  
INSTRUMENT D'AGRAFAGE CHIRURGICALE AYANT UNE DISTRIBUTION D'ÉNERGIE  
ULTRASONORE

---

(84) Designated Contracting States:  
**AL AT BE BG CH CY CZ DE DK EE ES FI FR GB GR HR HU IE IS IT LI LT LU LV MC MK MT NL NO PL PT RO RS SE SI SK SM TR**

(30) Priority: **10.02.2015 US 201514618255**

(43) Date of publication of application:  
**17.08.2016 Bulletin 2016/33**

(60) Divisional application:  
**17169332.8 / 3 225 191**

(73) Proprietor: **Covidien LP**  
**Mansfield, MA 02048 (US)**

(72) Inventors:  
• **CENICCOLA, Anthony**  
**Hamden, CT 06514 (US)**  
• **RACENET, David**  
**Killingsworth, CT 06419 (US)**

- **SNOW, Joshua**  
**Clinton, CT 06413 (US)**
- **NELSON, Anne**  
**Guilford, CT 06437 (US)**
- **CHOWANIEC, Matthew**  
**Middletown, CT 06457 (US)**
- **HODGKINSON, Gerald**  
**Guilford, CT 06437 (US)**
- **GLEIMAN, Seth**  
**Guilford, CT 06437 (US)**
- **SCHMITT, Jeffrey**  
**Trumbull, CT 06611 (US)**

(74) Representative: **Soames, Candida Jane**  
**Maschio & Soames IP Limited**  
**30 Carlton Crescent**  
**Southampton SO15 2EW (GB)**

(56) References cited:  
**EP-A1- 0 695 535 WO-A1-2013/119463**  
**US-A1- 2013 153 635 US-A1- 2015 011 988**

**EP 3 056 156 B1**

---

Note: Within nine months of the publication of the mention of the grant of the European patent in the European Patent Bulletin, any person may give notice to the European Patent Office of opposition to that patent, in accordance with the Implementing Regulations. Notice of opposition shall not be deemed to have been filed until the opposition fee has been paid. (Art. 99(1) European Patent Convention).

---

## Description

### BACKGROUND

#### 1. *Technical Field*

[0001] The present disclosure relates generally to surgical stapling instruments. More specifically, the present disclosure relates to stapling instruments including ultrasonic energy delivery.

#### 2. *Background of Related Art*

[0002] Surgical stapling instruments configured to join tissue portions during a surgical procedure are well known. These stapling instruments include linear end effectors which are oriented parallel or transverse to a longitudinal axis of the instrument. These stapling instruments also include circular end effectors.

[0003] Stapling instruments can include a knife that cuts tissue between staple lines. Alternatively, some stapling instruments include ultrasonic blades that cut tissue between the staple lines.

[0004] Surgical buttress material may be used in combination with stapling instruments to reinforce the staple lines to promote proper staple formation, reduce bleeding, and promote anastomosis of tissue.

[0005] EP 0 695 535 A1 describes an ultrasonic instrument for hemostatic cutting and/or cauterizing of tissue. WO 2013/119463 relates to the reinforcement of tissue.

### SUMMARY

[0006] The present invention provides an end effector that includes first and second jaws, first and second buttresses, and an ultrasonic blade. The first jaw includes a fastener cartridge that has a first tissue contacting surface and a plurality of fasteners arranged in rows parallel to a longitudinal axis of the first jaw. The second jaw includes a second tissue contacting surface. The first and second jaws are moveable relative to one another and are configured to grasp tissue therebetween. The first buttress is attached to the first tissue contacting surface. The second buttress is attached to the second tissue contacting surface. The ultrasonic blade is activatable to cut the first and second buttresses and tissue grasped between the first and second jaws and to subsequently weld the first buttress to the second buttress.

[0007] In aspects, the ultrasonic blade has a first portion that is disposed on the first tissue contacting surface between two rows of the plurality of fasteners. The ultrasonic blade may have a second portion that is disposed on the second tissue contacting surface opposing the first portion of the ultrasonic blade. The second portion may be parallel to a longitudinal axis of the second jaw.

[0008] In some aspects, the plurality of fasteners are ejectable from the fastener cartridge and are configured to secure the first and second buttresses about tissue

grasped between the first and second jaws. The plurality of fasteners may be staples and the second jaw may include an anvil for deforming the staples as the staples are ejected from the fastener cartridge.

5 [0009] In another aspect of the present disclosure, an end effector includes a first jaw, a second jaw, and an ultrasonic blade. The first jaw includes a fastener cartridge that has a first tissue contacting surface and a plurality of fasteners that are arranged in rows parallel to a longitudinal axis of the first jaw. The fastener cartridge defines a blade channel along its longitudinal axis. The second jaw includes a second tissue contacting surface and a protrusion that opposes the blade channel. The first and second jaws are moveable relative to one another and are configured to grasp tissue therebetween. The ultrasonic blade has first and second portions that are disposed within the blade channel. The first and second portions are each adjacent one of the opposing walls defining the blade channel. The first and second portions define a gap therebetween along the longitudinal axis of the first jaw. The protrusion is disposed within the gap when the first and second jaws are in an approximated configuration.

15 [0010] In aspects, the end effector includes a first buttress attached to the first tissue contacting surface and a second buttress attached to the second tissue contacting surface. The plurality of fasteners may be staples and the second jaw may include an anvil for deforming the staples as the staples are ejected from the fasteners cartridge.

20 [0011] The present disclosure is useful in a method of dissecting tissue that includes clamping tissue between opposing jaws of an end effector, ejecting fasteners from one of the opposing jaws, and activating an ultrasonic blade. Each of the opposing jaws may include a buttress attached to a tissue contacting surface. Ejecting the fasteners from one of the opposing jaws includes ejecting the fasteners through each of the buttresses to fasten the clamped tissue together. The fasteners are disposed in rows parallel to a longitudinal axis of the end effector. The ultrasonic blade is disposed in a blade channel disposed along the longitudinal axis of the end effector. Activating the ultrasonic blade cuts the tissue and welds the buttresses together. Clamping tissue between the opposing jaws of the end effector may include a protrusion on one jaw urging a portion of the tissue into the blade channel of the opposing jaw.

25 [0012] Further, to the extent consistent, any of the aspects described herein may be used in conjunction with any or all of the other aspects described herein.

### BRIEF DESCRIPTION OF THE DRAWINGS

30 [0013] Various aspects of the present disclosure are described hereinbelow with reference to the drawings, which are incorporated in and constitute a part of this specification, wherein:

FIG. 1A is a perspective view of a manually actuated handle assembly and a loading unit in accordance with the present disclosure;

FIG. 1B is a perspective view of an electromechanical instrument, an adaptor, and the loading unit of FIG. 1A;

FIG. 2 is an enlarged view of the indicated area of detail of FIG. 1A;

FIG. 3 is a cross-sectional view taken along the section line 3-3 with jaws approximated of FIG. 2;

FIG. 4 is a cross-sectional view taken along the section line 4-4 of FIG. 3;

FIG. 5 is a side cross-sectional view of tissue joined with the end effector of FIG. 2; and

FIG. 6 is a cross-sectional view similar to FIG. 4 of another end effector provided in accordance with the present disclosure.

#### DETAILED DESCRIPTION OF EMBODIMENTS

**[0014]** Embodiments of the present disclosure are now described in detail with reference to the drawings in which like reference numerals designate identical or corresponding elements in each of the several views. As used herein, the term "clinician" refers to a doctor, a nurse, or any other care provider and may include support personnel. Throughout this description, the term "proximal" refers to the portion of the device or component thereof that is closest to the clinician and the term "distal" refers to the portion of the device or component thereof that is farthest from the clinician.

**[0015]** FIGS. 1A and 1B illustrate a loading unit 10 having an end effector 20 in accordance with an embodiment of the present disclosure. The loading unit 10 is configured for connection to a manually actuated handle assembly or stapling instrument 100 such as described in U.S. Patent No. 8,789,737 ("the '737 Patent"). Alternatively, the loading unit 10 can be configured for selective connection to a powered hand held electromechanical instrument 200 via the adaptor 210. In such an embodiment, the adaptor 210 of the electromechanical instrument 200 may have a configuration similar to that of the elongated body portion 110 of the stapling instrument 100 as shown in FIG. 1A. The loading unit 10 is releasably coupled to a distal end 112 of the elongated body portion 110 of the manually actuated handle assembly 100 or to a distal end 212 of the adaptor 210 of the electromechanical instrument 200. The end effector 20 is operatively associated with an ultrasonic generator 300. As shown in FIG. 1A, the ultrasonic generator 300 may be external to the stapling instrument (e.g., stapling instrument 100 or electromechanical instrument 200). Alternatively, as

shown in FIG. 1B, the ultrasonic generator 300 may be incorporated into the stapling instrument (e.g., stapling instrument 100 or electromechanical instrument 200).

**[0016]** For a detailed description of the structure and function of an exemplary adaptor and loading unit, please refer to commonly owned U.S. Patent Publication No. 2012/0089131. For a detailed description of the structure and function of an exemplary electromechanical instrument, please refer to commonly owned U.S. Patent Publication Nos. 2012/0253329 and 2012/0323226. For a detailed description of the structure and function of an exemplary ultrasonic generator, please refer to commonly owned U.S. Patent No. 8,419,758.

**[0017]** Referring to FIGS. 2 and 3, the loading unit 10 includes a first or lower jaw 22 and a second or upper jaw 24. The upper and lower jaws 22, 24 are moveable relative to one another between a spaced-apart configuration (FIG. 2) and an approximated configuration (FIG. 3). The lower jaw 22 includes a fastener cartridge 30 having a plurality of staples 32 arranged in rows 33 on either side of a knife or lower blade channel 26 (FIG. 4). The fastener cartridge 30 may be releasably coupled to the lower jaw 22. The upper jaw 24 includes an anvil 40 that is configured to deform the staples 32 into formed staples as the staples 32 are ejected through openings 31 of the fastener cartridge 30 when the jaws 22, 24 are in the approximated configuration as detailed below.

**[0018]** Alternatively, the fastener cartridge 30 of the lower jaw 22 may include a plurality of fasteners (not explicitly shown) and the upper jaw 24 may include a retainer cartridge (not shown) that includes a plurality of retainers (not shown). As the fasteners are ejected from the fastener cartridge 30 of the first jaw 22, each of the fasteners forms a two-part fastener with one of the retainers of the retainer cartridge.

**[0019]** With additional reference to FIG. 4, the fastener cartridge 30 and the anvil 40 each include a tissue contacting surface 23, 25, respectively. The end effector 20 includes a buttress 50 releasably disposed on each of the tissue contacting surfaces 23, 25. The buttress 50 may be fabricated from a suitable biocompatible and bioabsorbable material. The buttress 50 may be fabricated from a non-absorbent material which does not retain fluid, or the buttress can be made from an absorbent material. For a detailed description of suitable materials for surgical buttresses, please refer to commonly owned U.S. Patent Nos. 5,542,594 ; 5,908,427 ; 5,964,774 ; 6,045,560 ; 7,823,592 ; and 7,938,307 , and commonly assigned U.S. Patent Publication No. 2010/0092710. As detailed below, the buttress 50 detaches from the tissue contacting surfaces 23, 25 of the fastener cartridge 30 and the anvil 40 when the staples 32 are ejected from the fastener cartridge 30. As discussed in greater detail below, the buttresses 50 may promote anastomosis, reduce bleeding, provide support for the tissue to facilitate a higher burst pressure, and distribute pressure from the fasteners to a larger area of tissue.

**[0020]** The anvil 40 defines an upper blade channel 28

that opposes the lower blade channel 26 of the fastener cartridge 30. An ultrasonic blade 54 is disposed in each of the blade channels 26, 28. The ultrasonic blades 54 are operatively associated with an ultrasonic generator 300 (FIG. 1A). The ultrasonic generator 300 provides ultrasonic energy to the ultrasonic blades 54 to ultrasonically translate the ultrasonic blades 54 within the blade channels 26, 28. As detailed below, the ultrasonic blades 54 are configured to cut tissue between the jaws 22, 24 along a cut line CL (FIG. 4) in the approximated configuration and to weld the buttress 50 attached to the tissue contacting surface 23 of the lower jaw 22 to buttress 50 attached to the tissue contacting surface 25 of the upper jaw 24.

**[0021]** Referring to FIGS. 4 and 5, the end effector 20 is used to fasten and divide tissue T in accordance with the present disclosure. The jaws 22, 24 of the end effector 20 are approximated over tissue T to be fastened and divided. With layers of the tissue T positioned between the jaws 22, 24, the staples 32 are ejected from the fastener cartridge 30 of the lower jaw 22 towards the anvil 40 of the upper jaw 24. The staples 32 pass through the buttresses 50 and are formed in staple pockets 41 defined by the anvil 40 such that the staples 32 are disposed on either side of the tissue to urge the buttresses 50 towards one another. The staple pockets 41 deform legs of the staples 32 towards one another such that the staples 32 fasten the layers of tissue T to one another. The buttresses 50 compress the layers of tissue T therebetween to promote anastomosis of the tissue T. The ultrasonic blades 54 are then supplied with ultrasonic energy to cut the layers of tissue T between the ultrasonic blades 54 along the cut line CL. As the ultrasonic blades 54 cut the tissue T between the ultrasonic blades 54, the ultrasonic blades 54 weld the buttresses 50 together adjacent the central cut line CL. The weld W (FIG. 5) of the buttresses 50 helps seal the cut portion of the tissue T.

**[0022]** By welding the buttresses 50 together adjacent the cut line CL of the tissue T, bleeding of the tissue T may be reduced when compared to anastomosis from stapling alone. Further, by stapling through the buttresses 50 adjacent the cut line CL, the ultrasonic blades 54 may be used to cut and seal tissue T having a greater thickness when compared to an ultrasonic dissector alone.

**[0023]** Referring now to FIG. 6, another end effector 120 is provided in accordance with the present disclosure. The end effector 120 is similar to the end effector 20 detailed above with like structures represented with similar labels, as such only the differences will be discussed in detail below. A lower jaw 122 includes a fastener cartridge 130 and has a stepped tissue contacting surface 123. It is within the scope of this disclosure, that the tissue contacting surface 125 of the anvil 140 may also have a stepped configuration similar to the stepped configuration of the tissue contacting surface 123 of the fastener cartridge 130. The stepped configuration of the tissue contacting surfaces 123, 125 compress tissue T

between the jaws 122, 124 in a step like manner which may allow tissue having a greater thickness to be stapled and cut. The fastener cartridge 130 defines a blade channel 126 between rows of fasteners 132. Two ultrasonic blades 154 are disposed within the blade channel 126 adjacent walls defining the blade channel 126.

**[0024]** The tissue contacting surface 125 of the upper jaw 124 includes a protrusion 156 opposing the blade channel 126 of the fastener cartridge 130. The protrusion 156 extends into the blade channel 126 when the jaws 122, 124 are in the approximated configuration as shown in FIG. 6. The protrusion 156 urges the tissue T into the blade channel 126 and may compress the tissue T into the blade channel 126. As shown, the protrusion 156 has a triangular cross-sectional shape; however, the protrusion 156 may have a variety of shapes that fit within the blade channel 126 of the lower jaw 122 (e.g., semi-circular, rectangular, pentagonal, etc.). When the tissue T is within the blade channel 126, the fasteners 132 are ejected from the fastener cartridge 130 and the ultrasonic blades 154 are activated to cut and seal the tissue T. The protrusion 156 being received within the blade channel 126 may also align the fastener cartridge 130 and the anvil 140.

**[0025]** It is contemplated that the tissue contacting surfaces 123, 125 of the fastener cartridge 130 and the anvil 140 may include buttresses (not explicitly shown) as detailed above to provide additional support to the tissue T as the tissue is stapled and cut. The buttresses may also be welded together adjacent the cutlines of the ultrasonic blades 154 as detailed above.

**[0026]** It is also contemplated that the protrusion 156 may include an ultrasonic blade such that after the tissue T is stapled and sealed, the ultrasonic blade of the protrusion 156 is activated to cut the tissue along a tip 156a of the protrusion 156.

**[0027]** While several embodiments of the disclosure have been shown in the drawings, it is not intended that the disclosure be limited thereto, as it is intended that the disclosure be as broad in scope as the art will allow and that the specification be read likewise. For example, in any of the embodiments disclosed herein, the surgical instrument can include one or more electrosurgical components, such as monopolar or bipolar components for cutting, cauterizing, and/or sealing tissue or buttress material. Therefore, the above description should not be construed as limiting, but merely as exemplifications of particular embodiments. Those skilled in the art will envision other modifications within the scope of the claims appended hereto.

## Claims

1. An end effector (20) comprising:

a first jaw (22) including a fastener cartridge (30) having a first tissue contacting surface (23) and

a plurality of fasteners (32) arranged in rows (33) parallel to a longitudinal axis of the first jaw; a second jaw (24) including a second tissue contacting surface (25), the first and second jaws movable relative to one another and configured to grasp tissue therebetween; and an ultrasonic blade (54) activatable to cut tissue grasped between the first and second jaws;  
**characterized by:**

- a first buttress (50) attached to the first tissue contacting surface; and  
 a second buttress (50) attached to the second tissue contacting surface;  
 wherein the ultrasonic blade is activatable to cut the first and second buttresses and tissue grasped between the first and second jaws and to subsequently weld the first buttress to the second buttress.
2. The end effector according to claim 1, wherein the ultrasonic blade (54) has a first portion disposed on the first tissue contacting surface between two rows of the plurality of fasteners.
  3. The end effector according to claim 2, wherein the ultrasonic blade (54) has a second portion disposed on the second tissue contacting surface opposing the first portion of the ultrasonic blade.
  4. The end effector according to any preceding claim, wherein the ultrasonic blade (54) has a second portion disposed on the second tissue contacting surface parallel to a longitudinal axis of the second jaw.
  5. The end effector according to any preceding claim, wherein the plurality of fasteners (32) are ejectable from the fastener cartridge (30) and are configured to secure the first and second buttresses (50) about tissue grasped between the first and second jaws.
  6. The end effector according to any preceding claim, wherein the plurality of fasteners (32) are staples and the second jaw (24) includes an anvil (40) for deforming the staples as the staples are ejected from the fastener cartridge.
  7. An end effector according to claim 1 wherein the fastener cartridge defines a blade channel (126) along its longitudinal axis;  
 the second jaw includes a protrusion (156) opposing the blade channel, and  
 the ultrasonic blade (154) has first and second portions disposed within the blade channel, the first and second portions each adjacent one of opposing walls defining the blade channel, the first and second portions defining a gap therebetween along the longitudinal axis of the first jaw, the protrusion disposed

within the gap when the first and second jaws are in an approximated configuration.

## 5 Patentansprüche

### 1. Ein Endeffektor (20), umfassend:

eine erste Backe (22), die eine Befestigungselement-Kartusche (30) aufweist, mit einer ersten, Gewebe kontaktierenden Fläche (23) und mehreren Befestigungselementen (32), die in Reihen (33) parallel zu einer Längsachse der ersten Backe angeordnet sind;

eine zweite Backe (24), die eine zweite Gewebe kontaktierende Fläche (25) aufweist, wobei erste und zweite Backe relativ zueinander bewegt werden können und konfiguriert sind, Gewebe zwischen ihnen zu erfassen; und

eine Ultraschallklinge (54), die aktivierbar ist, um zwischen der ersten und zweiten Backe erfasstes Gewebe zu schneiden;

#### **gekennzeichnet durch:**

eine erste Gegenstütze (50) die an der ersten, Gewebe kontaktierenden Fläche befestigt ist; und

eine zweite Gegenstütze (50), die an der zweiten, Gewebe kontaktierenden Fläche befestigt ist;

wobei die Ultraschallklinge aktiviert werden kann, um erste und zweite Gegenstütze und zwischen der ersten und zweiten Backe erfasstes Gewebe zu schneiden und nachfolgend die erste Gegenstütze an die zweite Gegenstütze anzuschweißen.

2. Endeffektor nach Anspruch 1, wobei die Ultraschallklinge (54) einen ersten Abschnitt hat, der auf der ersten, Gewebe kontaktierenden Fläche zwischen zwei Reihen der mehreren Befestigungselemente angeordnet ist.

3. Endeffektor nach Anspruch 2, wobei die Ultraschallklinge (54) einen zweiten Abschnitt hat, der auf der zweiten Gewebe kontaktierenden Fläche gegenüber dem ersten Abschnitt der Ultraschallklinge angeordnet ist.

4. Endeffektor nach einem vorhergehenden Anspruch, wobei die Ultraschallklinge (54) einen zweiten Abschnitt hat, der auf der zweiten, Gewebe kontaktierenden Fläche parallel zu einer Längsachse der zweiten Backe angeordnet ist.

5. Endeffektor nach einem vorhergehenden Anspruch, wobei die mehreren Befestigungselemente (32) aus der Befestigungselement-Kartusche (30) ausgestoßen werden können und konfiguriert sind, die erste und zweite Gegenstütze (50) um zwischen erster und zweiter Backe erfasstes Gewebe herum zu befestigen.
6. Endeffektor nach einem vorhergehenden Anspruch, wobei die mehreren Befestigungselemente (32) Heftklammern sind und die zweite Backe (24) einen Amboss (40) zum Verformen der Heftklammern aufweist, wenn die Heftklammern aus der Befestigungselement-Kartusche ausgestoßen werden.
7. Endeffektor nach Anspruch 1, wobei die Befestigungselement-Kartusche einen Klingenkana1 (126) entlang ihrer Längsachse definiert; die zweite Backe einen Vorsprung (156) gegenüber dem Klingenkana1 aufweist und die Ultraschallklinge (154) einen ersten und zweiten Abschnitt hat, die innerhalb des Klingenkana1 angeordnet sind, wobei der erste und zweite Abschnitt, jeweils einer der gegenüberliegenden Wände angrenzend, den Klingenkana1 definieren und der erste und zweite Abschnitt eine Lücke dazwischen entlang der Längsachse der ersten Backe definieren, und der Vorsprung innerhalb der Lücke angeordnet ist, wenn die erste und zweite Backe sich in einer approximierten Konfiguration befinden.

## Revendications

1. Effecteur terminal (20) comprenant :

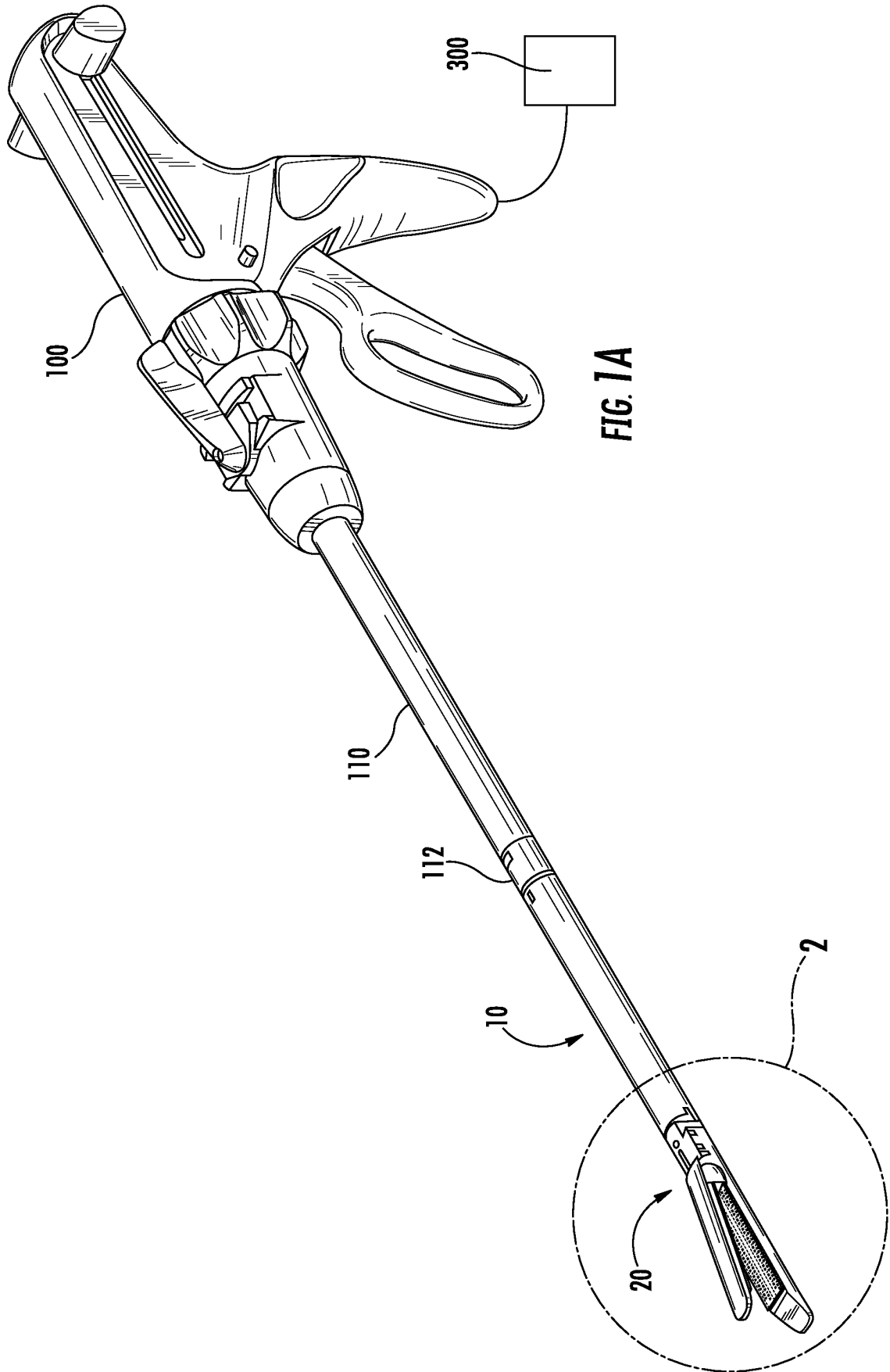
un premier mors (22) comprenant une cartouche d'attaches (30) ayant une première surface (23) en contact avec un tissu et une pluralité d'attaches (32) agencées en rangées (33) parallèlement à un axe longitudinal du premier mors ;  
 un second mors (24) comprenant une seconde surface (25) en contact avec le tissu, le premier et le second mors pouvant se déplacer l'un par rapport à l'autre et étant configurés pour saisir le tissu entre eux ; et  
 une lame ultrasonique (54) activable pour couper le tissu saisi entre le premier et le second mors ;

### caractérisé par :

un premier support (50) fixé à la première surface en contact avec le tissu ; et  
 un second support (50) fixé à la seconde surface en contact avec le tissu ;  
 dans lequel la lame ultrasonique est activable pour couper le premier et le second sup-

port ainsi que le tissu saisi entre le premier et le second mors et pour souder ensuite le premier support au second support.

2. Effecteur terminal selon la revendication 1, dans lequel la lame ultrasonique (54) a une première partie disposée sur la première surface en contact avec le tissu entre deux rangées de la pluralité d'attaches.
3. Effecteur terminal selon la revendication 2, dans lequel la lame ultrasonique (54) a une seconde partie disposée sur la seconde surface en contact avec le tissu à l'opposé de la première partie de la lame ultrasonique.
4. Effecteur terminal selon l'une quelconque des revendications précédentes, dans lequel la lame ultrasonique (54) a une seconde partie disposée sur la seconde surface en contact avec le tissu parallèlement à un axe longitudinal du second mors.
5. Effecteur terminal selon l'une quelconque des revendications précédentes, dans lequel la pluralité d'attaches (32) est éjectable de la cartouche d'attaches (30) et est configurée pour fixer le premier et le second support (50) autour du tissu saisi entre le premier et le second mors.
6. Effecteur terminal selon l'une quelconque des revendications précédentes, dans lequel la pluralité d'attaches (32) est formée d'agrafes et le second mors (24) comprend une enclume (40) pour déformer les agrafes à mesure que les agrafes sont éjectées de la cartouche d'attaches.
7. Effecteur terminal selon la revendication 1, dans lequel la cartouche d'attaches définit un canal de lame (126) le long de son axe longitudinal ; le second mors comprend une saillie (156) opposée au canal de lame et la lame ultrasonique (154) a une première et une seconde partie disposées dans le canal de lame, la première et la seconde partie étant adjacentes chacune de l'une des parois opposées définissant le canal de lame, la première et la seconde partie définissant un espacement entre elles le long de l'axe longitudinal du premier mors, la saillie étant disposée dans l'espacement lorsque le premier et le second mors sont en configuration rapprochée.



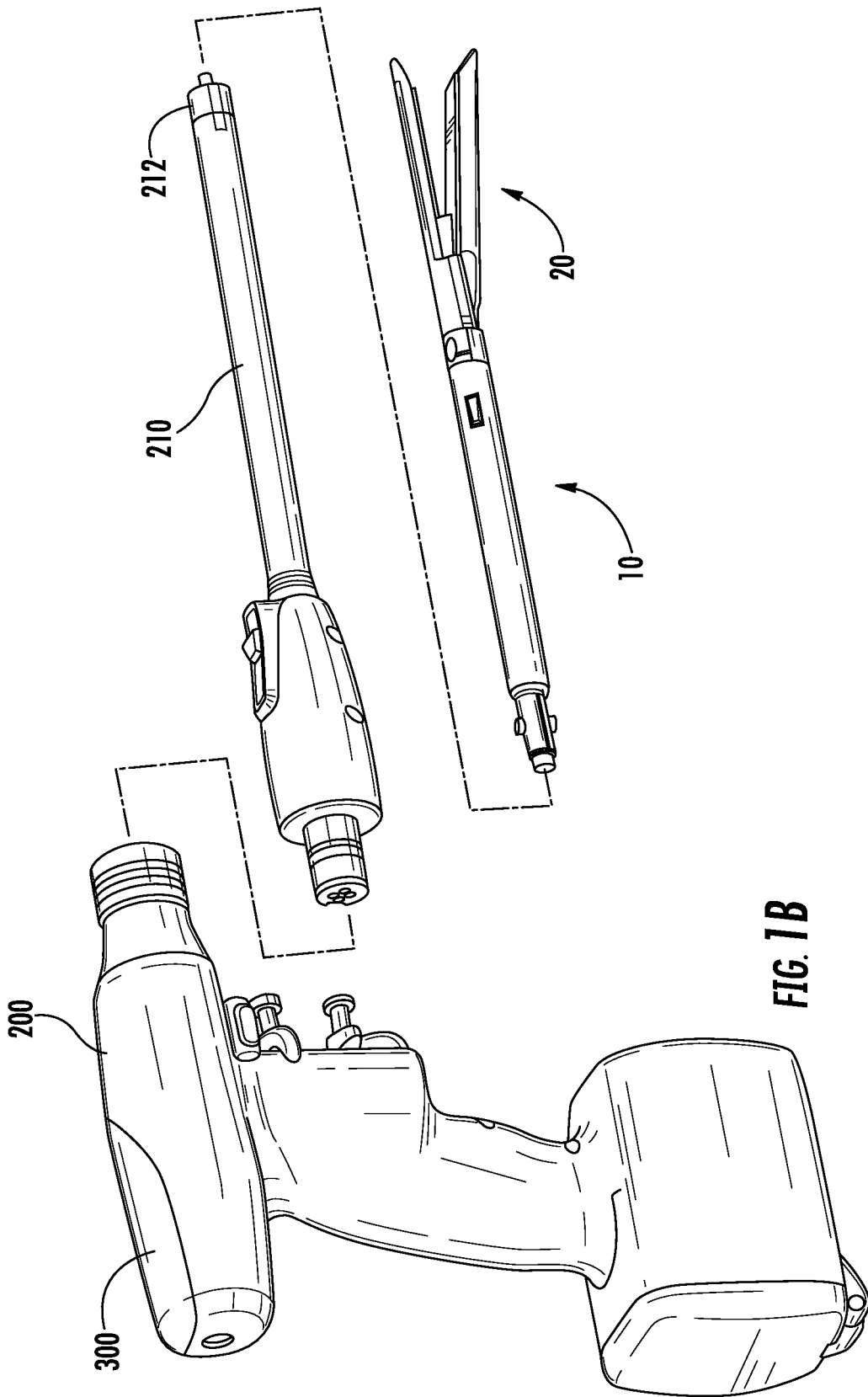
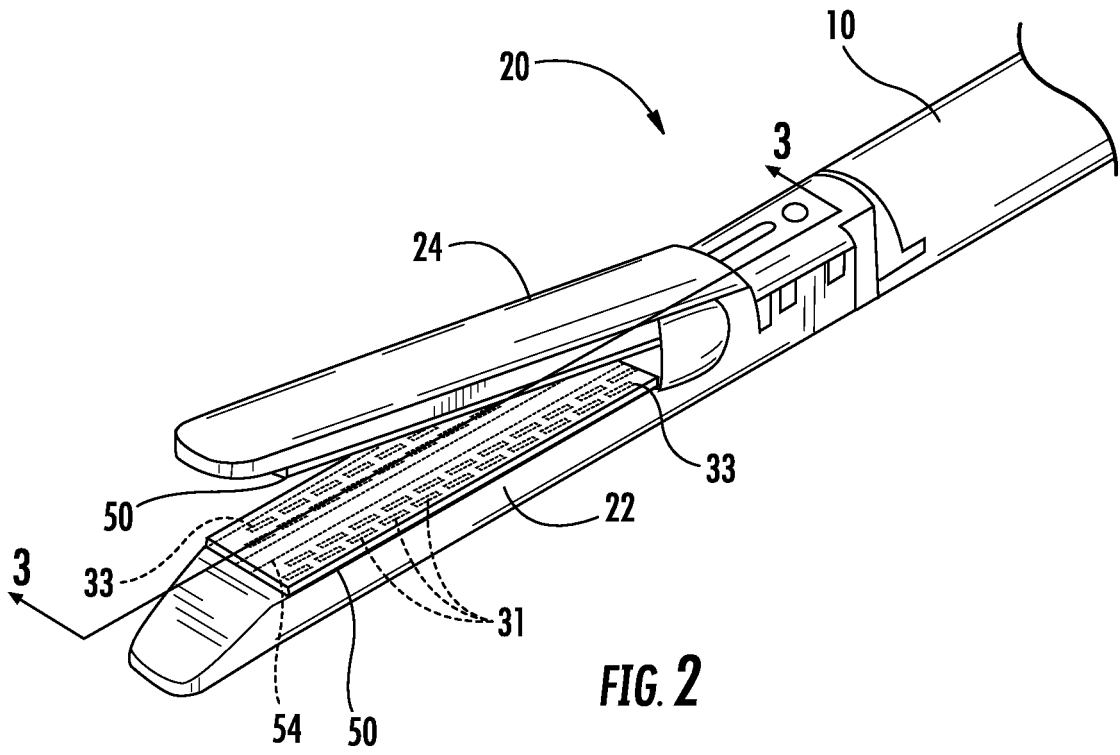
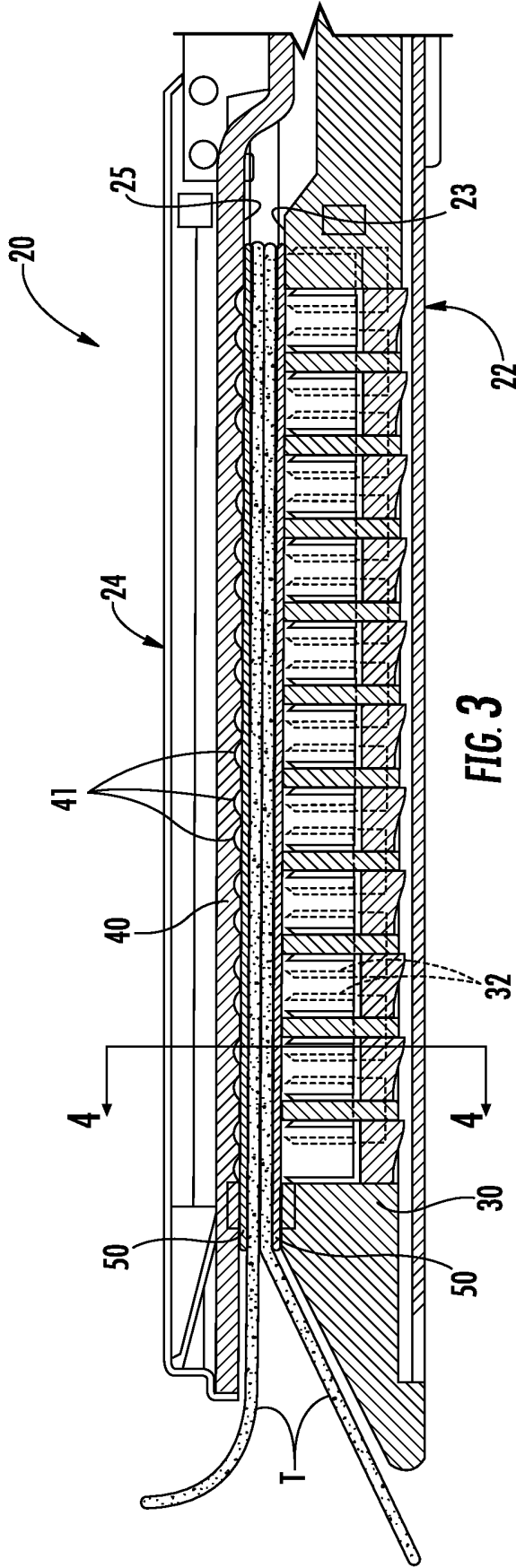
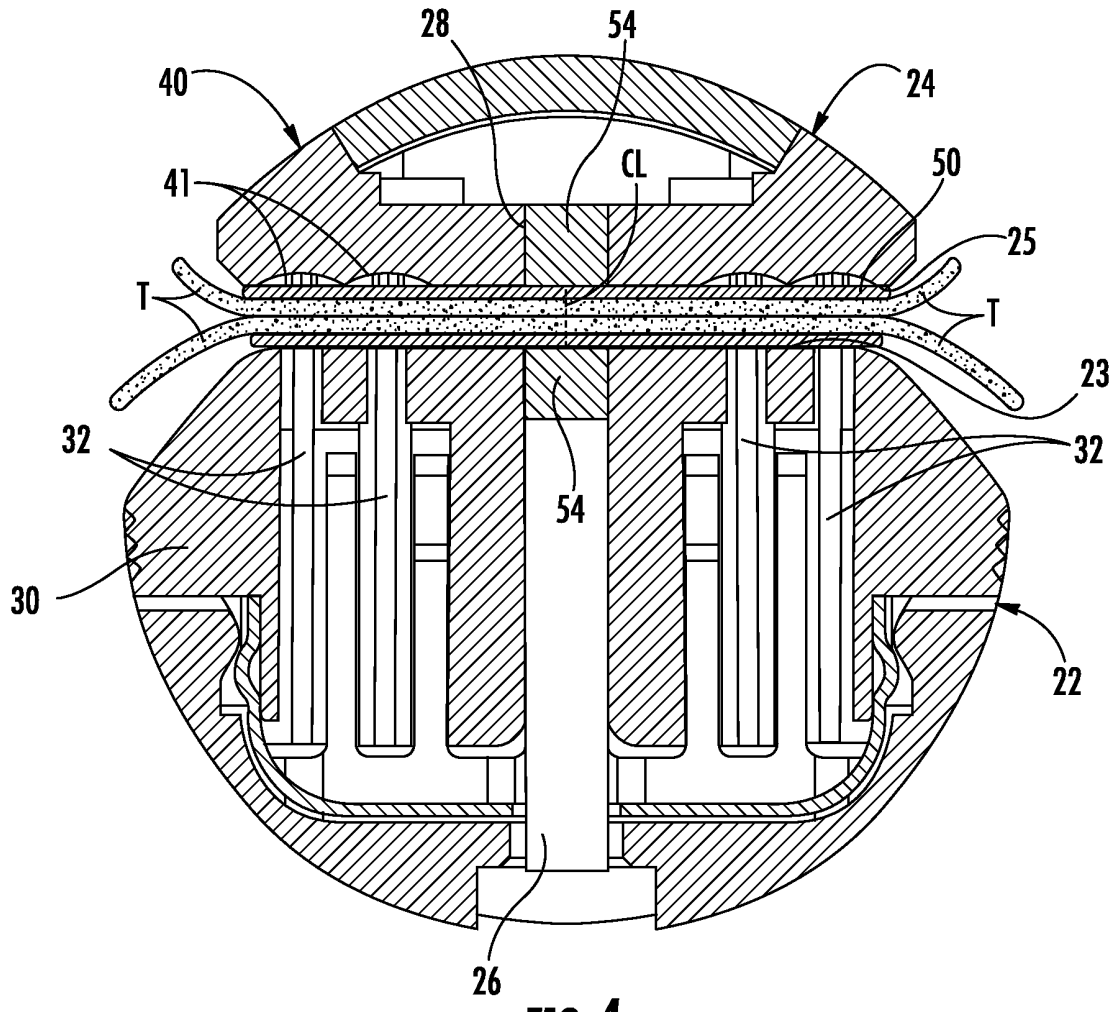


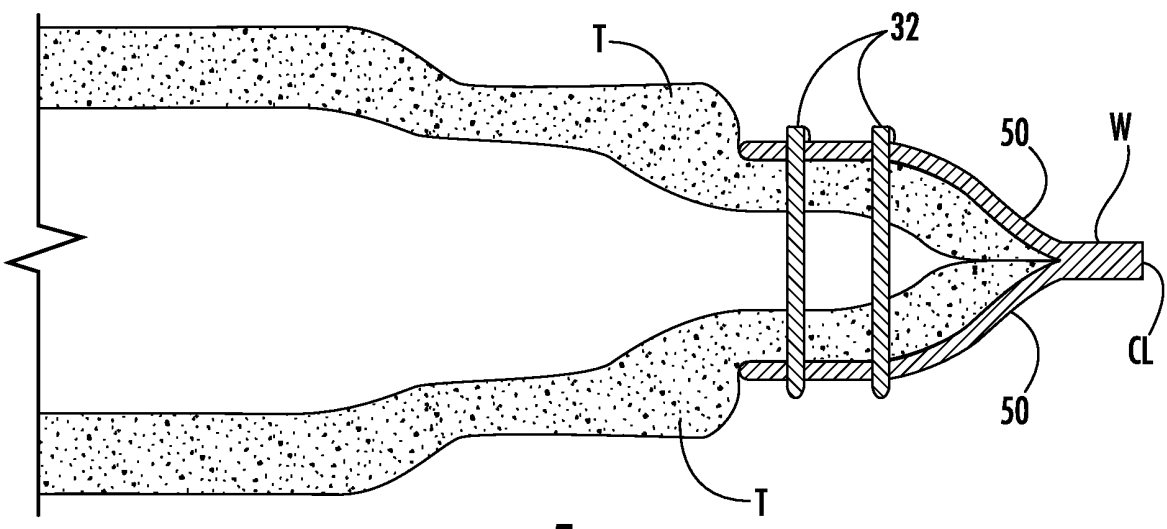
FIG. 1B



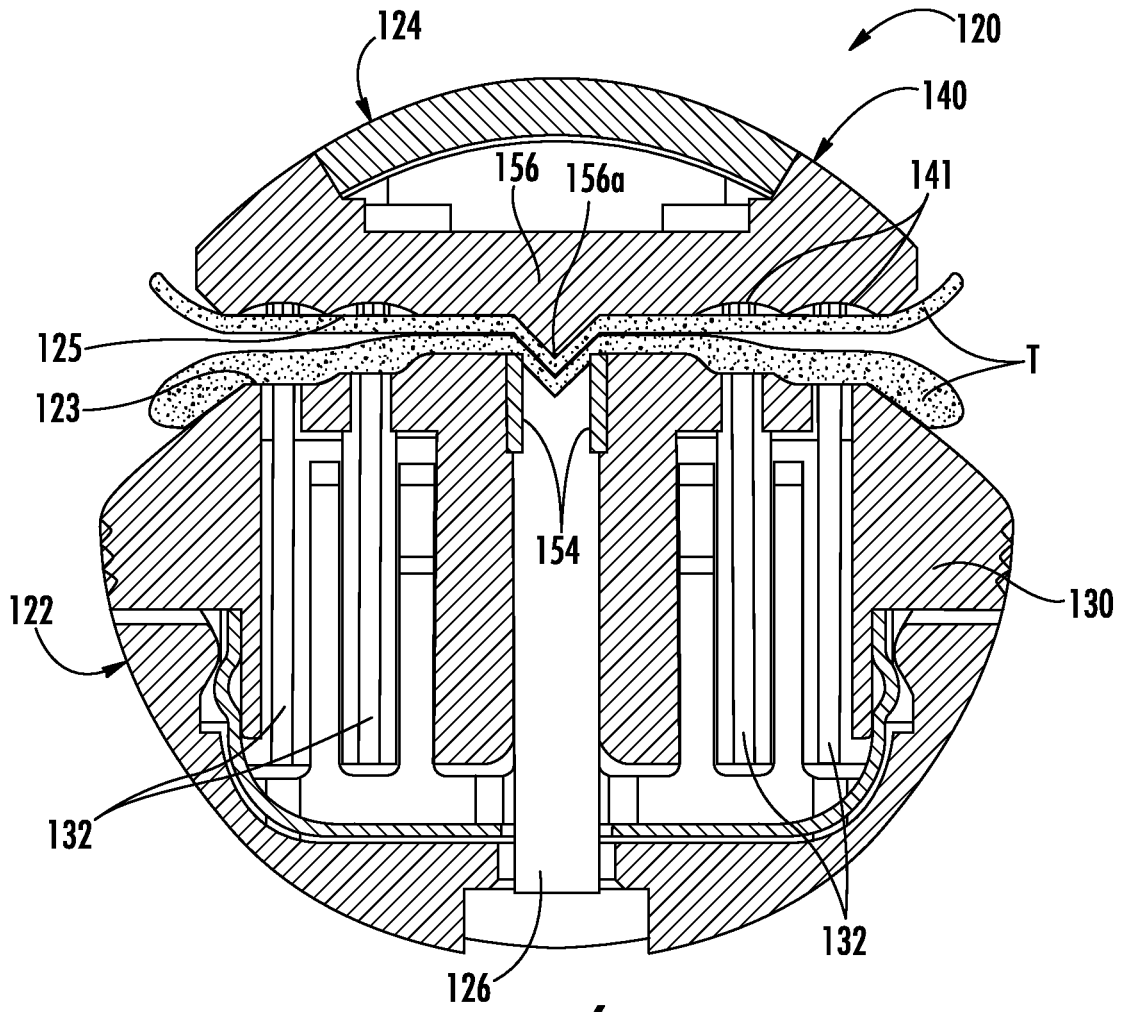




**FIG. 4**



**FIG. 5**



**FIG. 6**

**REFERENCES CITED IN THE DESCRIPTION**

*This list of references cited by the applicant is for the reader's convenience only. It does not form part of the European patent document. Even though great care has been taken in compiling the references, errors or omissions cannot be excluded and the EPO disclaims all liability in this regard.*

**Patent documents cited in the description**

- EP 0695535 A1 [0005]
- WO 2013119463 A [0005]
- US 8789737 B [0015]
- US 20120089131 A [0016]
- US 20120253329 A [0016]
- US 20120323226 A [0016]
- US 8419758 B [0016]
- US 5542594 A [0019]
- US 5908427 A [0019]
- US 5964774 A [0019]
- US 6045560 A [0019]
- US 7823592 B [0019]
- US 7938307 B [0019]
- US 20100092710 A [0019]

专利名称(译)	具有超声能量输送的外科缝合器械		
公开(公告)号	<a href="#">EP3056156B1</a>	公开(公告)日	2017-12-13
申请号	EP2016154792	申请日	2016-02-09
[标]申请(专利权)人(译)	柯惠有限合伙公司		
申请(专利权)人(译)	COVIDIEN LP		
当前申请(专利权)人(译)	COVIDIEN LP		
[标]发明人	CENICCOLA ANTHONY RACENET DAVID SNOW JOSHUA NELSON ANNE CHOWANIEC MATTHEW HODGKINSON GERALD GLEIMAN SETH SCHMITT JEFFREY		
发明人	CENICCOLA, ANTHONY RACENET, DAVID SNOW, JOSHUA NELSON, ANNE CHOWANIEC, MATTHEW HODGKINSON, GERALD GLEIMAN, SETH SCHMITT, JEFFREY		
IPC分类号	A61B17/072 A61B17/32		
CPC分类号	A61B17/07207 A61B17/320016 A61B17/320068 A61B17/320092 A61B17/3209 A61B2017/07257 A61B2017/07285 A61B17/0643 A61B17/07292 A61B2017/07242 A61B2017/320094 A61B2017/ /320095 A61B2017/320097		
优先权	14/618255 2015-02-10 US		
其他公开文献	EP3056156A3 EP3056156A2		
外部链接	<a href="#">Espacenet</a>		

#### 摘要(译)

末端执行器包括第一和第二钳口，第一和第二支柱，以及超声刀。第一钳口包括紧固件盒，紧固件盒具有第一组织接触表面和多个紧固件，所述紧固件成行布置成平行于第一钳口的纵向轴线。第一支撑件附接到第一组织接触表面，第二支撑件附接到第二钳口的第二组织收缩表面。第一钳口和第二钳口可相对于彼此移动，并构造造成抓住其间的组织。超声波可被激活以将第一支撑件焊接到第二支撑件并随后切割焊接的第一和第二支撑件以及夹在第一和第二钳口之间的组织。

