



US 20160022257A1

(19) **United States**

(12) **Patent Application Publication**  
**Bonadio et al.**

(10) **Pub. No.: US 2016/0022257 A1**  
(43) **Pub. Date: Jan. 28, 2016**

(54) **WOUND RETRACTOR DEVICE**

Oct. 14, 1999 (IE) ..... 990861

Dec. 16, 1999 (IE) ..... 991053

(71) Applicant: **Atropos Limited**, County Wicklow (IE)

Feb. 18, 2000 (EP) ..... 00650010

(72) Inventors: **Frank Bonadio**, County Wicklow (IE);  
**John Butler**, County Mayo (IE); **Trevor**  
**Vaugh**, County Offaly (IE); **Shane J.**  
**MacNally**, County Wicklow (IE); **Alan**  
**Reid**, Dublin (IE)

**Publication Classification**

(51) **Int. Cl.**  
**A61B 17/02** (2006.01)  
**A61B 17/34** (2006.01)

(21) Appl. No.: **14/753,796**

(52) **U.S. Cl.**  
CPC ..... **A61B 17/0293** (2013.01); **A61B 17/3498**  
(2013.01); **A61B 17/3423** (2013.01); **A61B**  
**2017/0225** (2013.01); **A61B 2017/3443**  
(2013.01); **A61B 2017/0212** (2013.01)

(22) Filed: **Jun. 29, 2015**

**Related U.S. Application Data**

(63) Continuation of application No. 13/655,286, filed on Oct. 18, 2012, now Pat. No. 9,095,300, which is a continuation of application No. 12/426,438, filed on Apr. 20, 2009, now Pat. No. 8,317,691, which is a continuation of application No. 10/678,653, filed on Oct. 6, 2003, now Pat. No. 7,559,893, which is a continuation-in-part of application No. 10/133,979, filed on Apr. 29, 2002, now Pat. No. 6,846,287, which is a continuation of application No. 09/801,826, filed on Mar. 9, 2001, now abandoned, which is a continuation of application No. PCT/IE99/00122, filed on Dec. 1, 1999, said application No. 10/678,653 is a continuation-in-part of application No. 10/374,523, filed on Feb. 27, 2003, now Pat. No. 7,445,597, which is a continuation of application No. 09/849,341, filed on May 7, 2001, now Pat. No. 6,582,364, which is a continuation of application No. 09/688,138, filed on Oct. 16, 2000, now Pat. No. 6,254,534.

(57) **ABSTRACT**

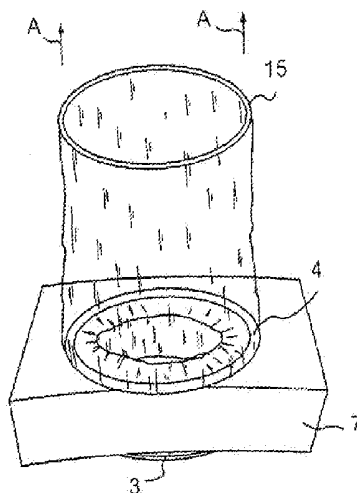
A wound protector and retractor device **1** comprises a sleeve **2**, a distal member provided by a distal ring **3** of resilient material and a proximal member provided by a proximal ring **4**. The sleeve **2** is led around the ring **3** and is free to move axially relative to the distal ring **3** somewhat in the manner of a pulley. The proximal ring **4** is fixed to the sleeve **2**, in this case at the proximal inner end thereof. The sleeve **2** terminates in a handle or gripping portion which is reinforced by a gripping ring **15**. The sleeve extends from the proximal ring **4** and the distal ring **3** is contained between inner and outer layers **2a**, **2b** of the sleeve **2**. The resilient distal ring **3** is scrunched up and inserted through the incision **6**. The sleeve **2** is then pulled upwardly. On pulling of the sleeve **2** upwardly the outer layer **2b** is pulled up while the inner layer **2a** is drawn around the proximal ring **3**. This results in shortening the axial extent between the proximal ring **4** and the distal ring **3**, tensioning the sleeve and applying a retraction force to the margins of the incision **6**. As the incision is being retracted the margins are also protected by the sleeve. On retraction, an access port is provided, for example for a surgeon to insert his hand and/or an instrument to perform a procedure. The device may be used as a retractor in open surgery or as a base for a valve/seal to allow it to be used in hand assisted laparoscopic surgery or for instrument access or hand access generally.

(60) Provisional application No. 60/415,780, filed on Oct. 4, 2002, provisional application No. 60/428,215, filed on Nov. 22, 2002, provisional application No. 60/490,909, filed on Jul. 30, 2003.

(30) **Foreign Application Priority Data**

Dec. 1, 1998 (IE) ..... 980997

Feb. 15, 1999 (IE) ..... 990111



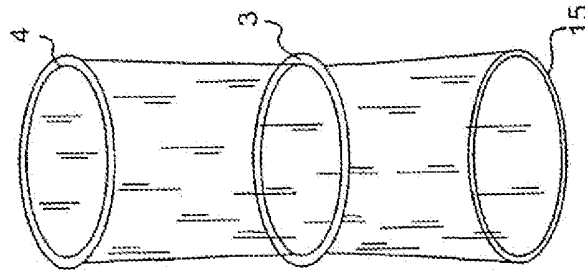
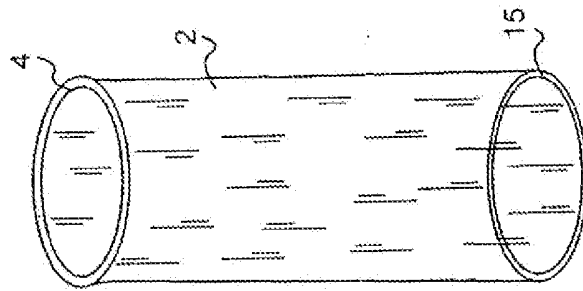
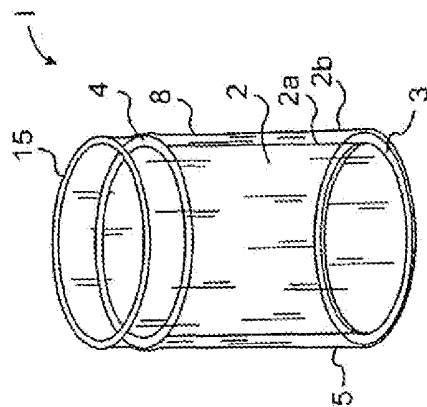


FIG. 1

FIG. 3

FIG. 4

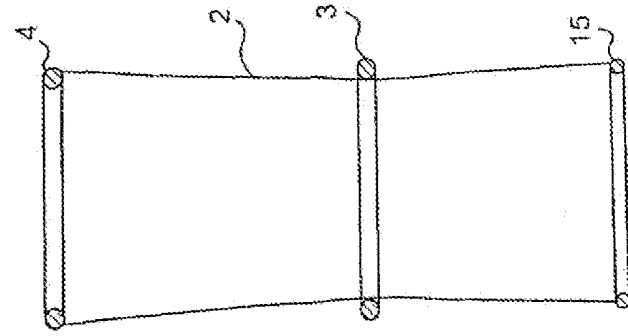


FIG. 2

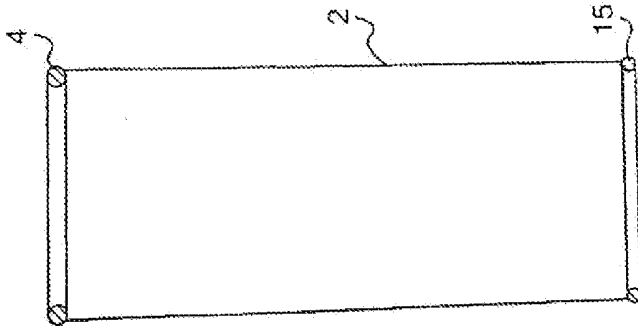


FIG. 5

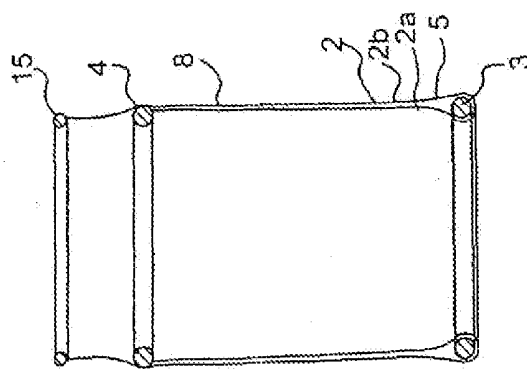


FIG. 6

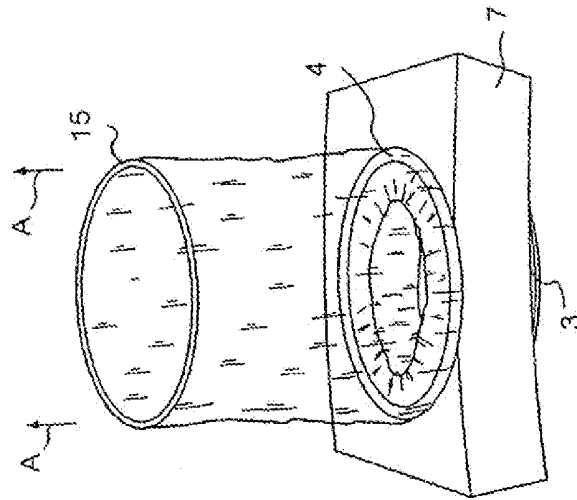


FIG. 8

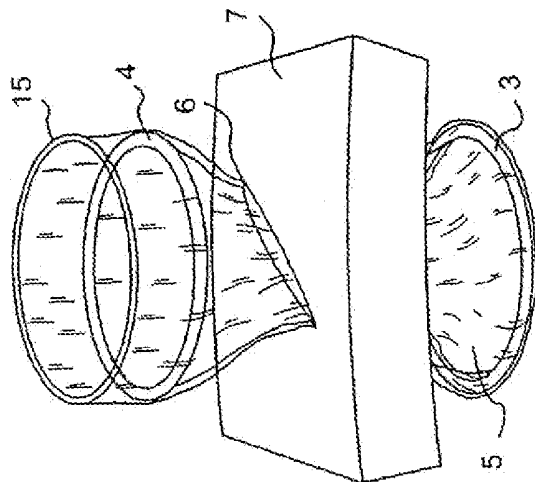


FIG. 7

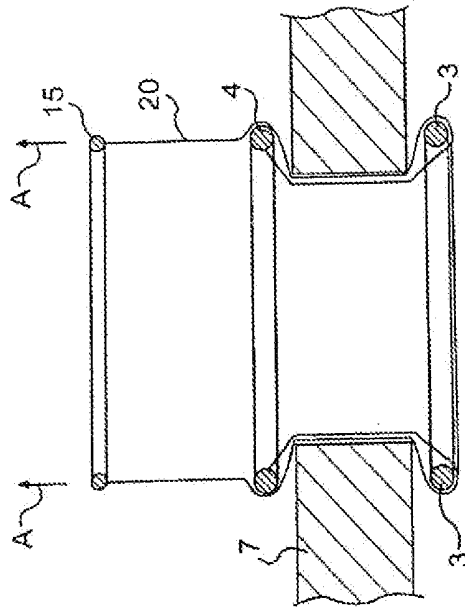


FIG. 9

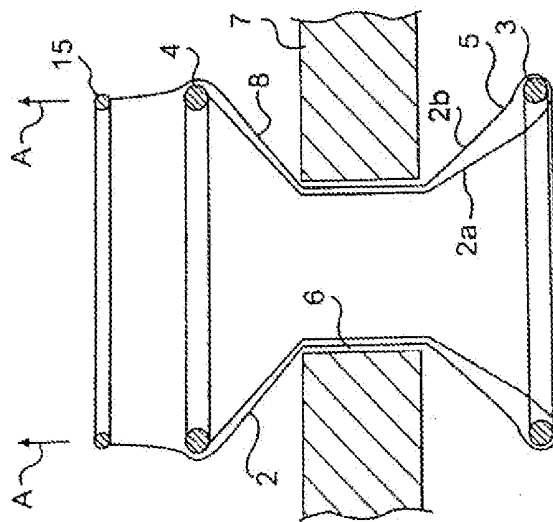
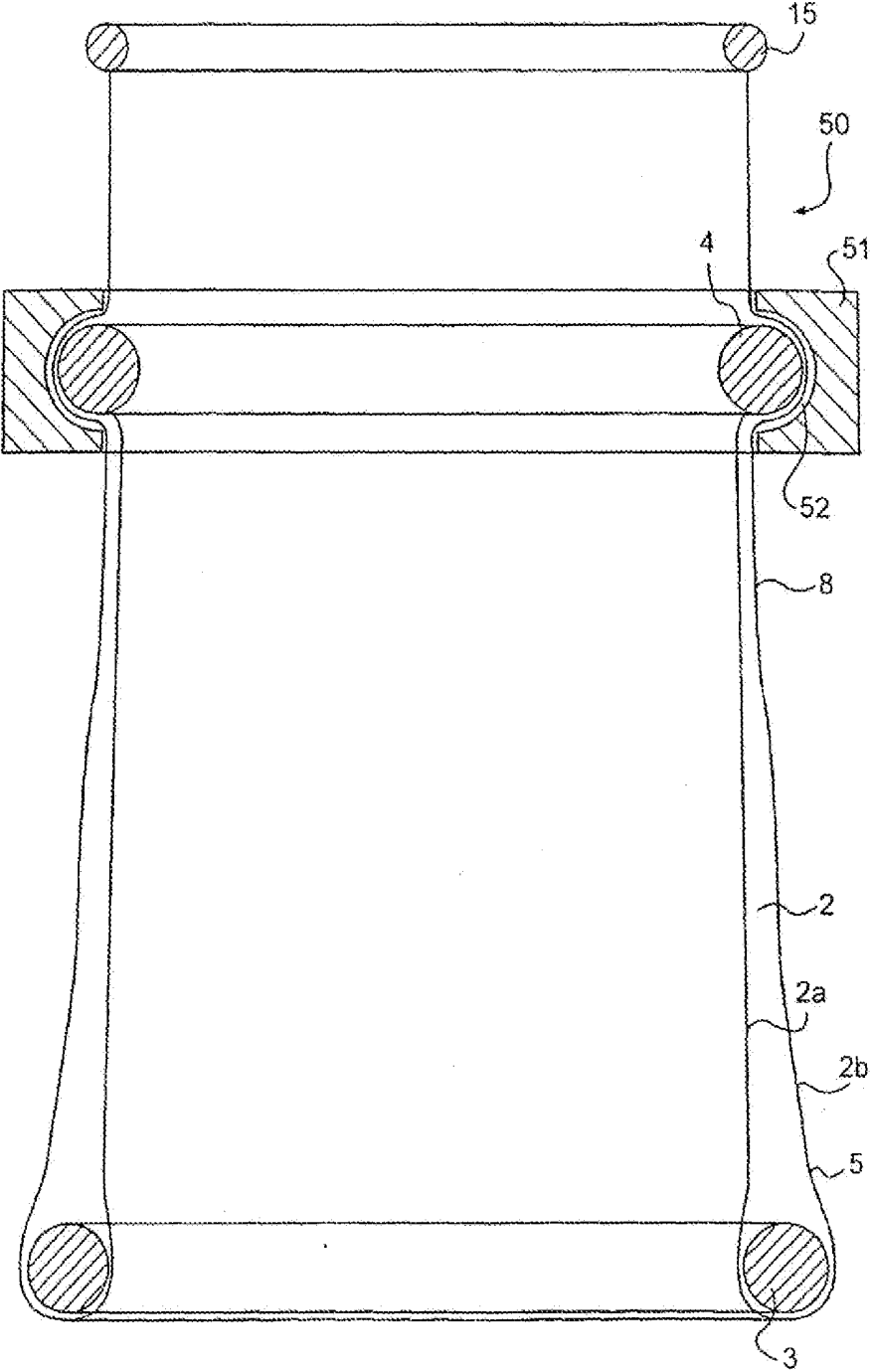
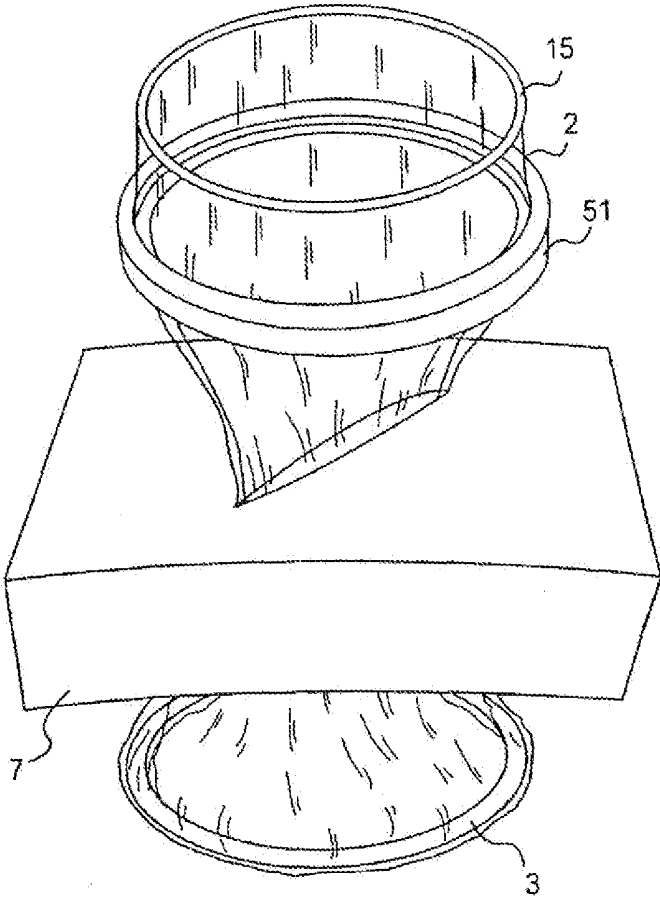


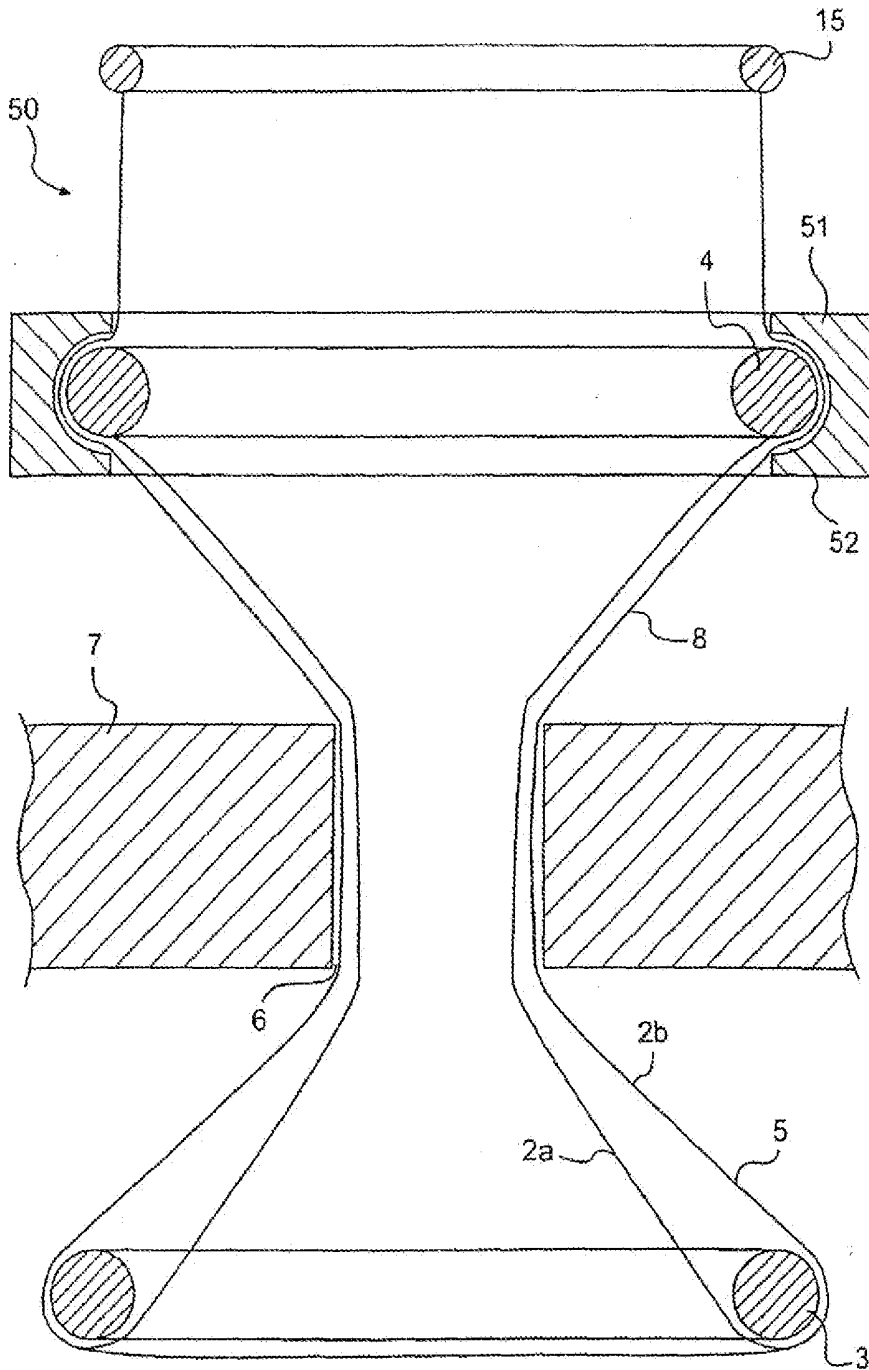
FIG. 10



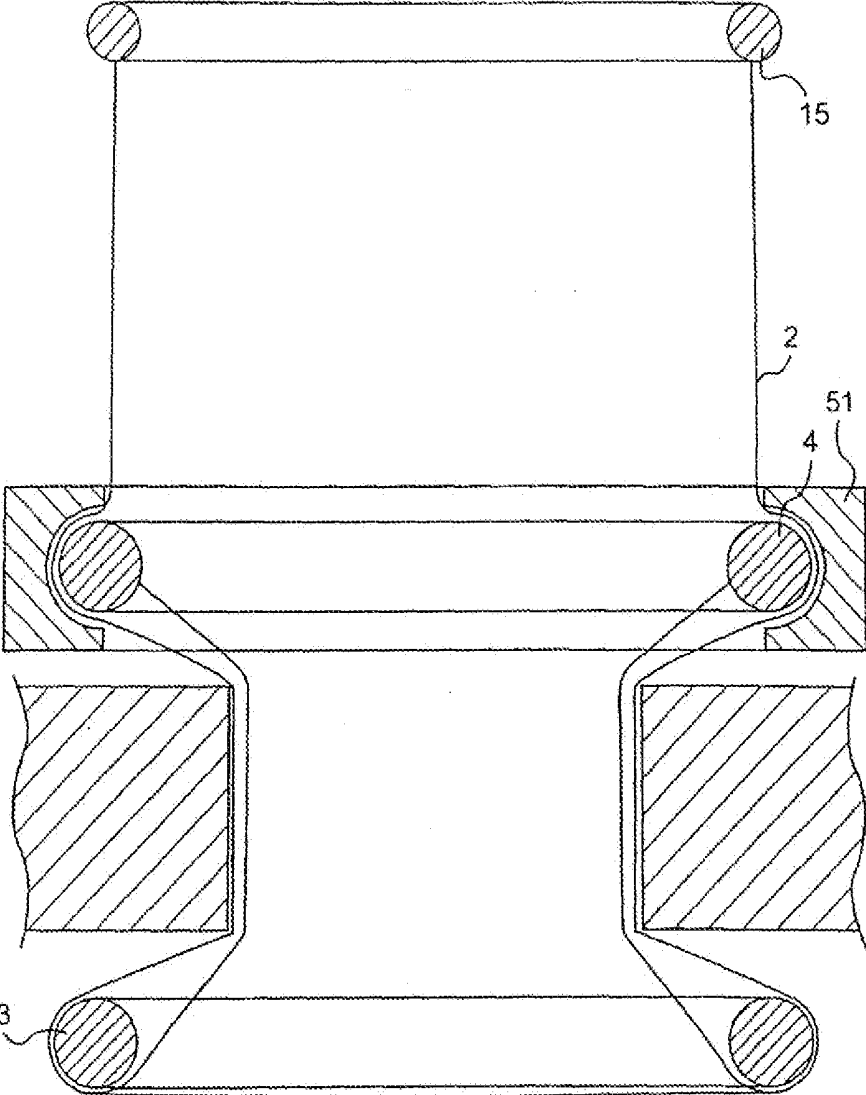
**FIG. 11**



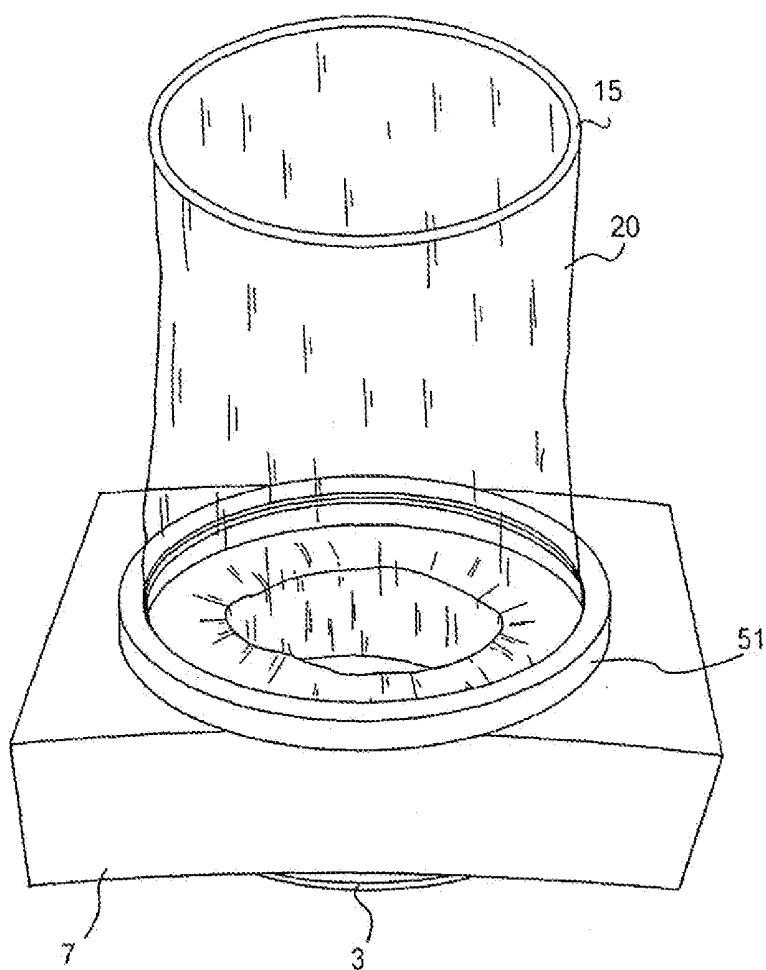
**FIG. 12**



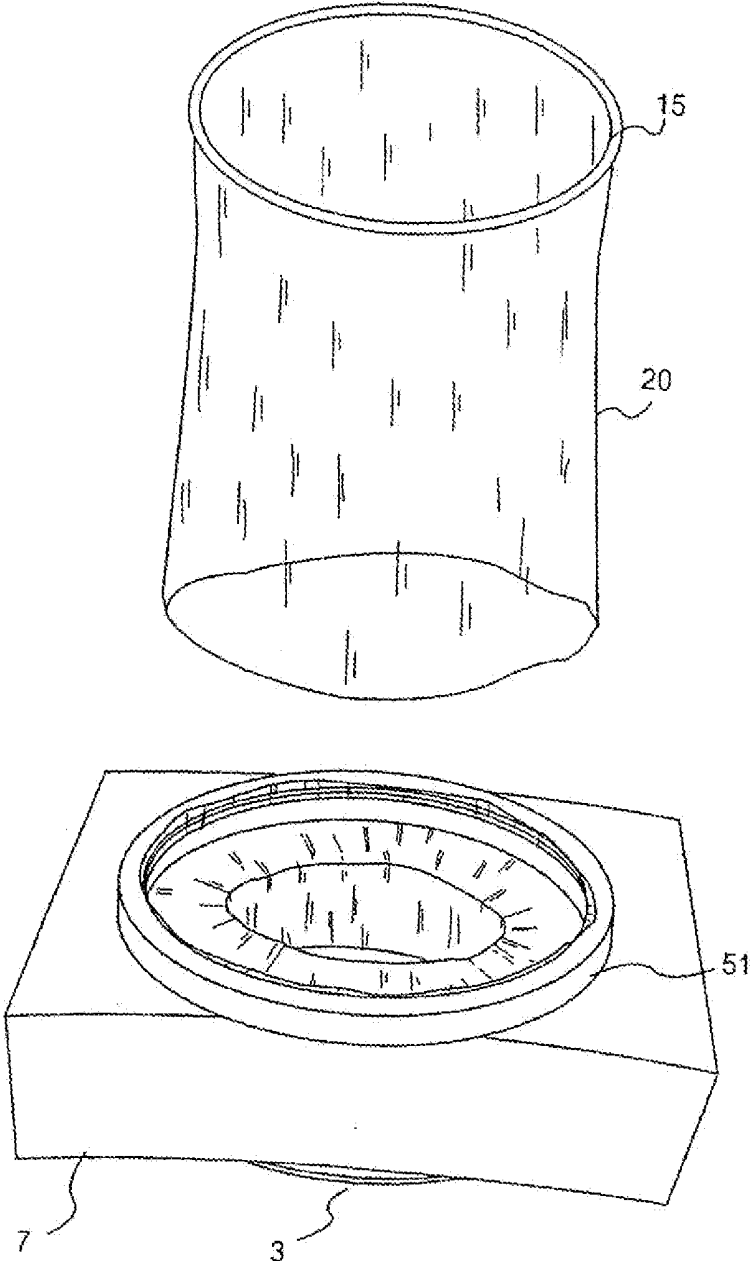
**FIG. 13**



**FIG. 14**



**FIG. 15**



**FIG. 16**

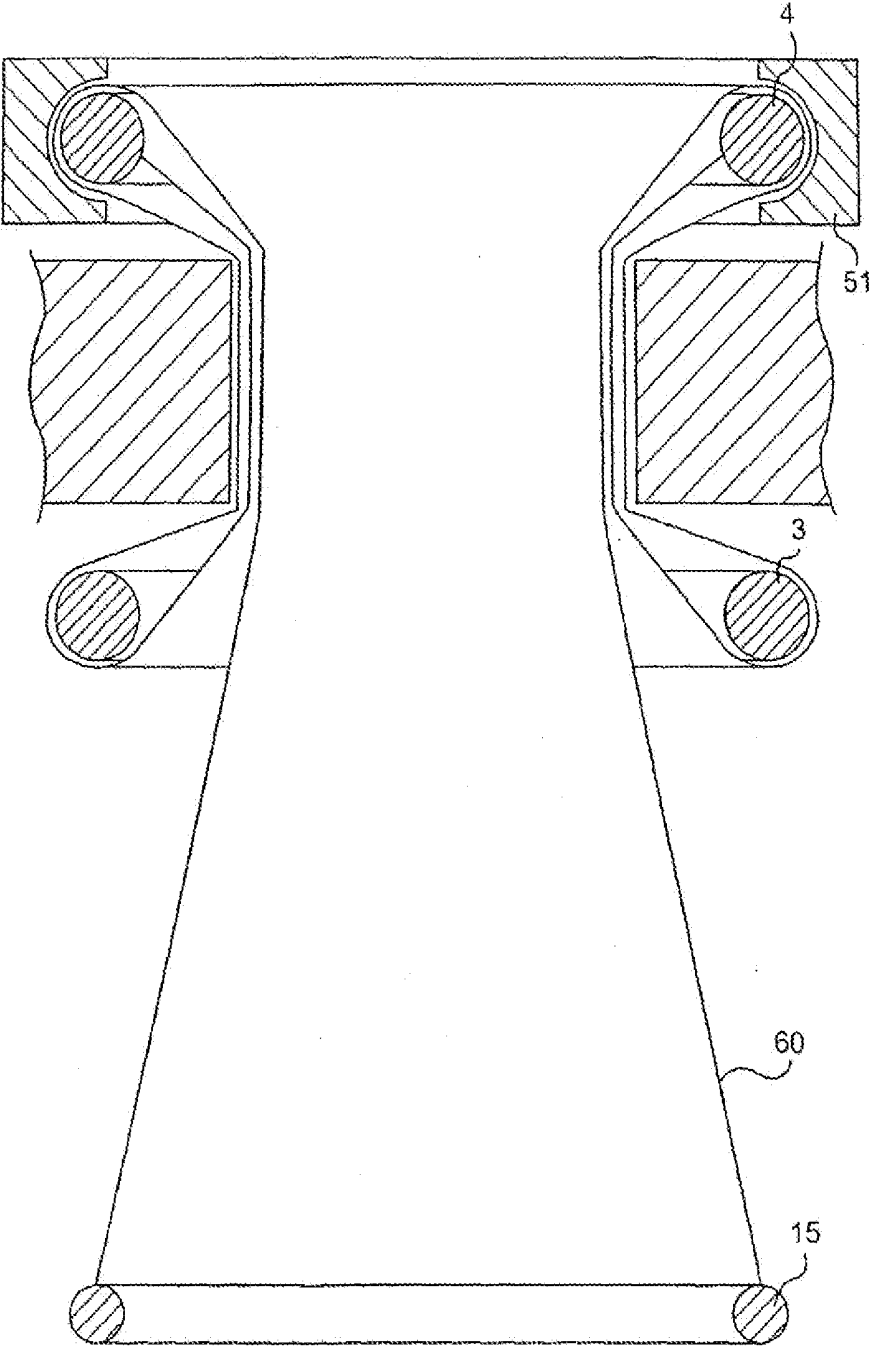
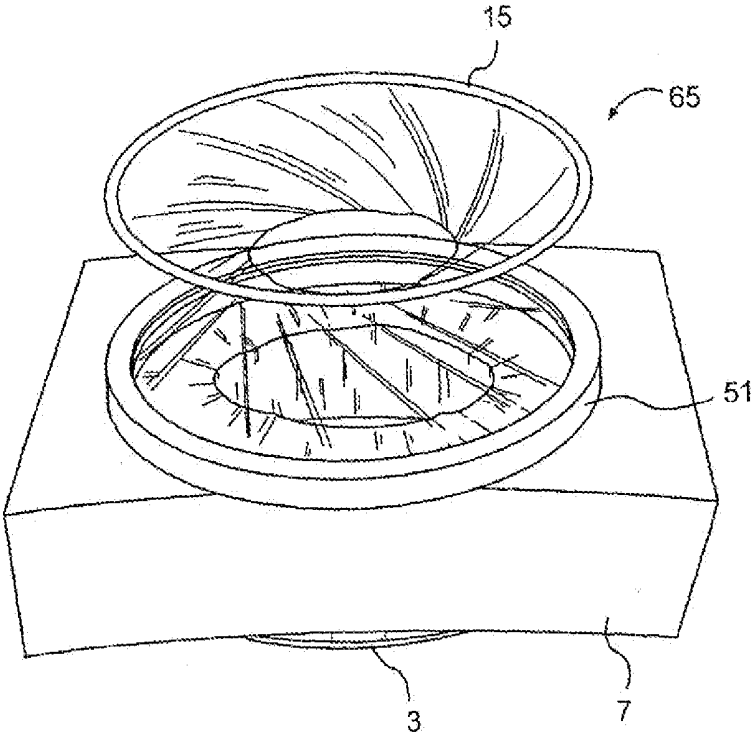


FIG. 17



**FIG. 18**

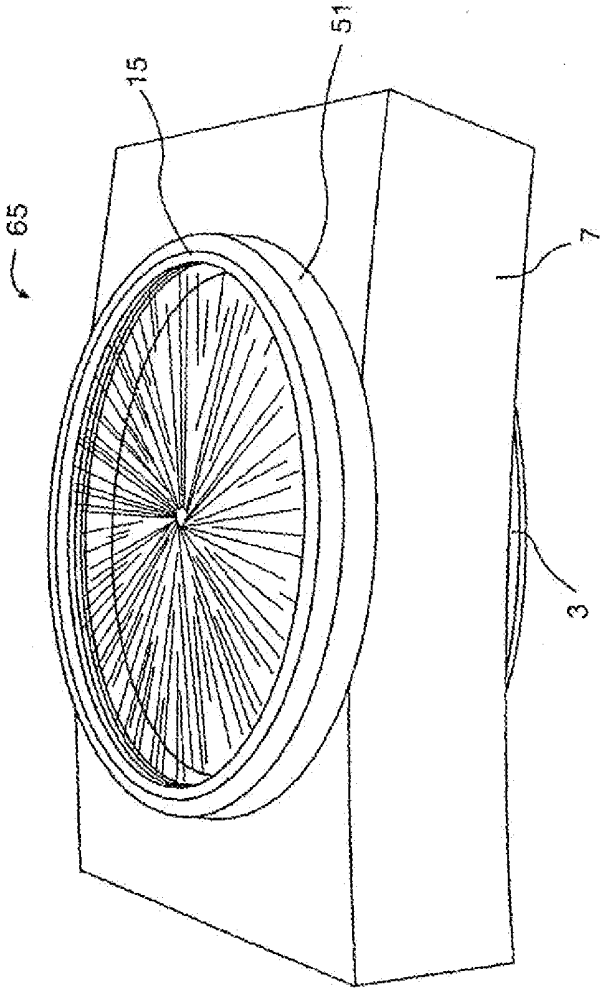
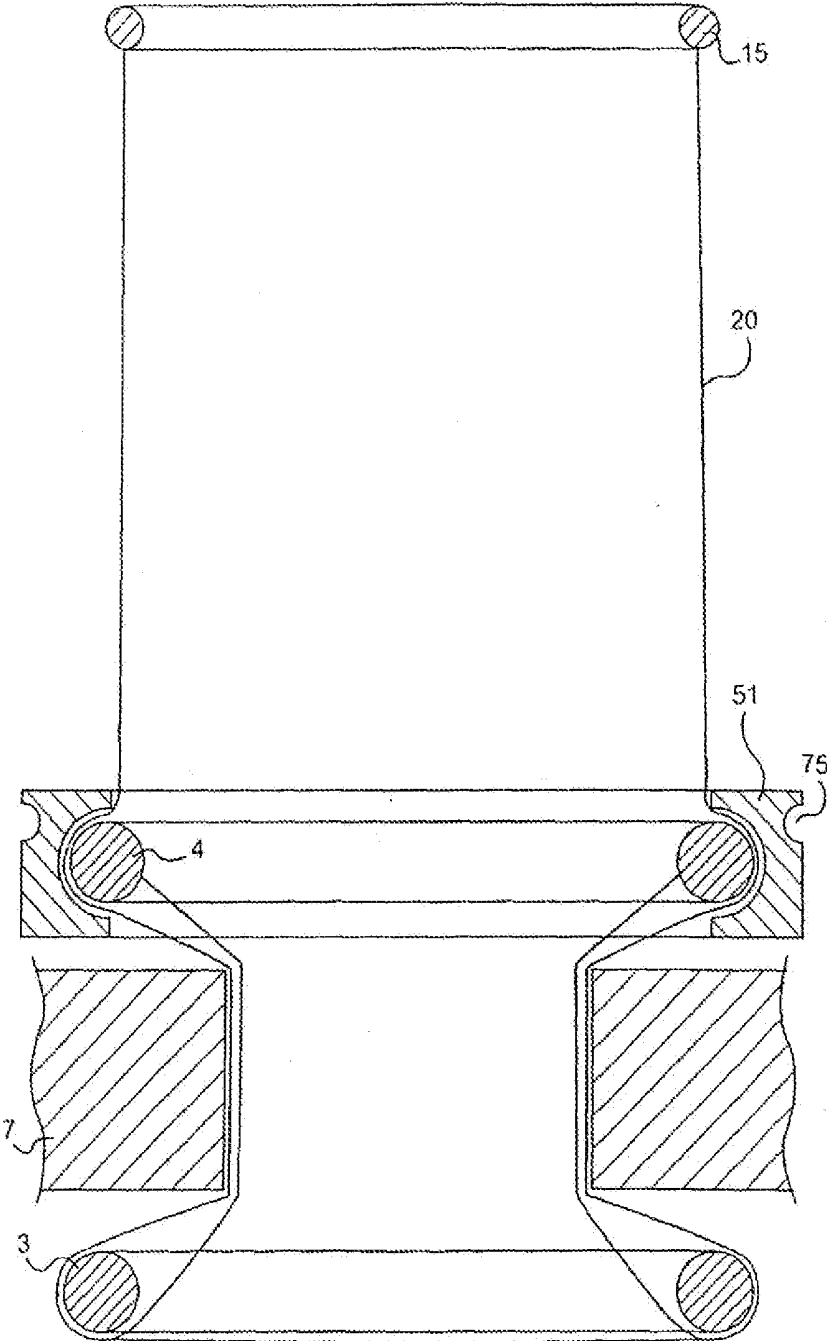
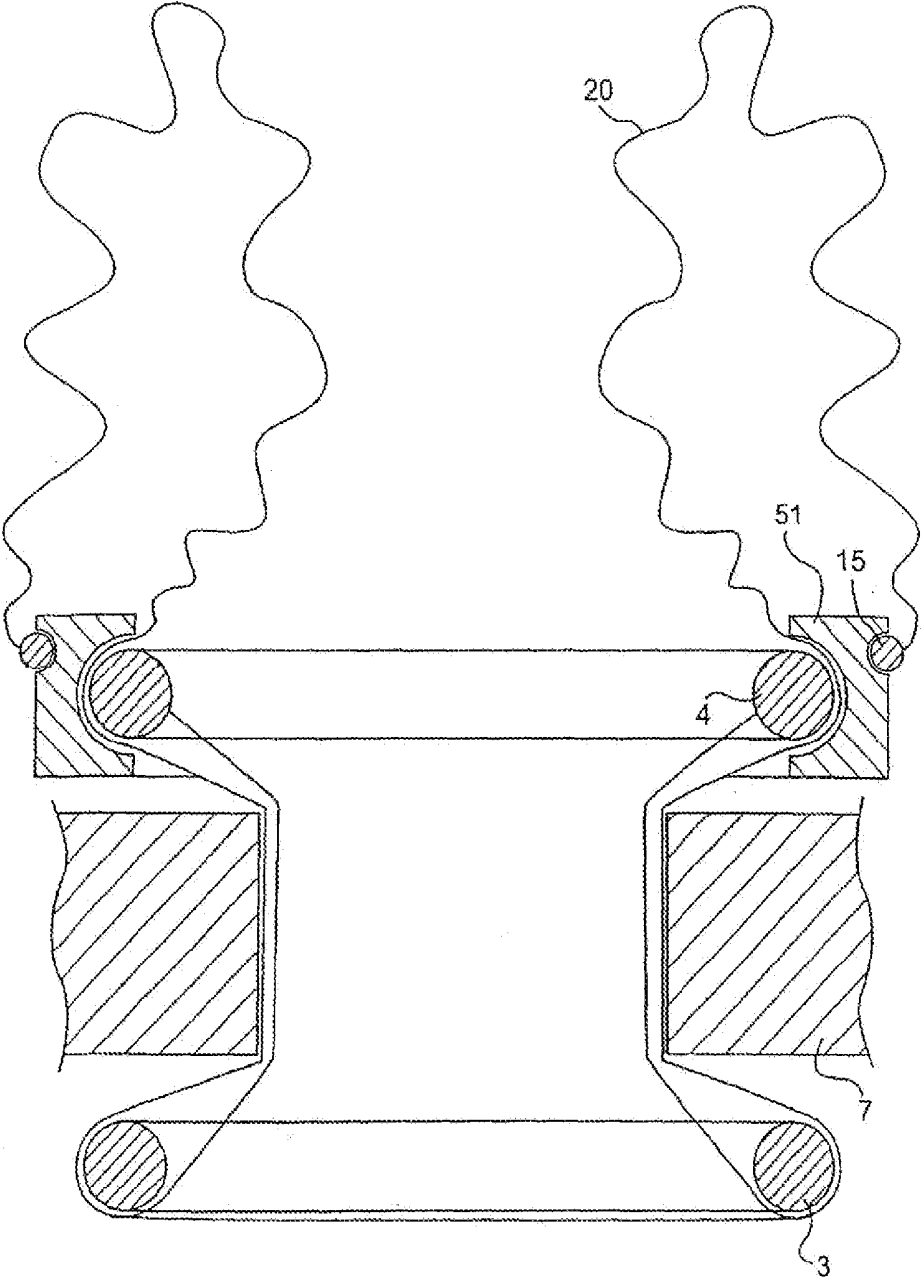


FIG. 19



**FIG. 20**



**FIG. 21**

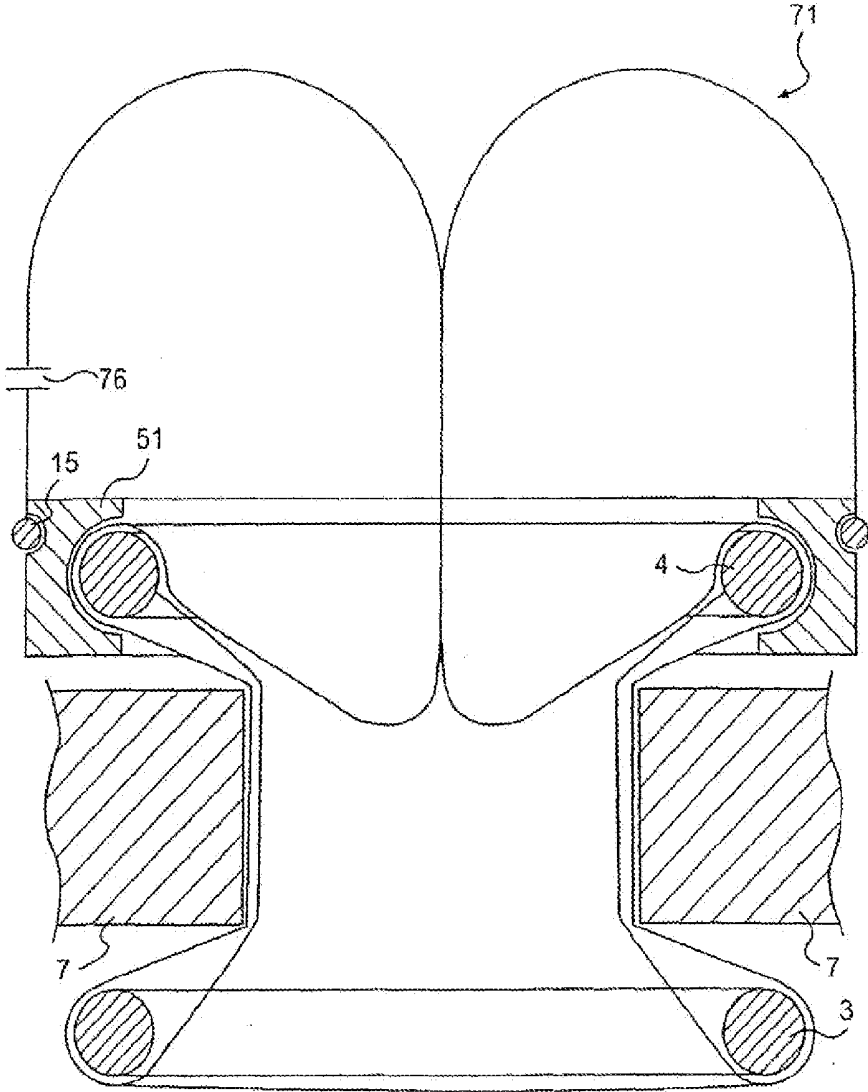
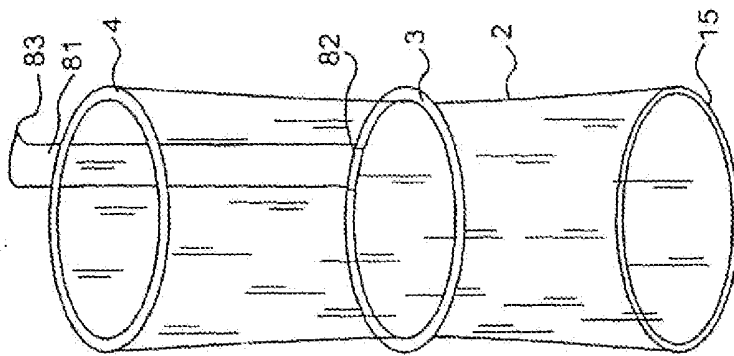
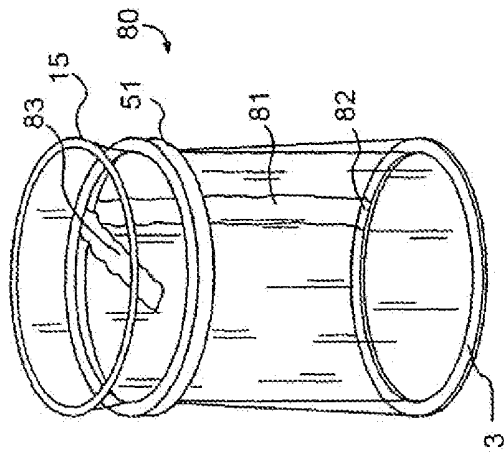


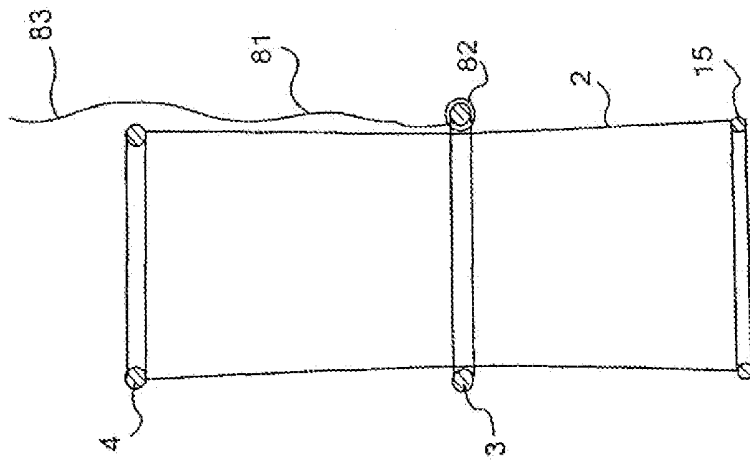
FIG. 22



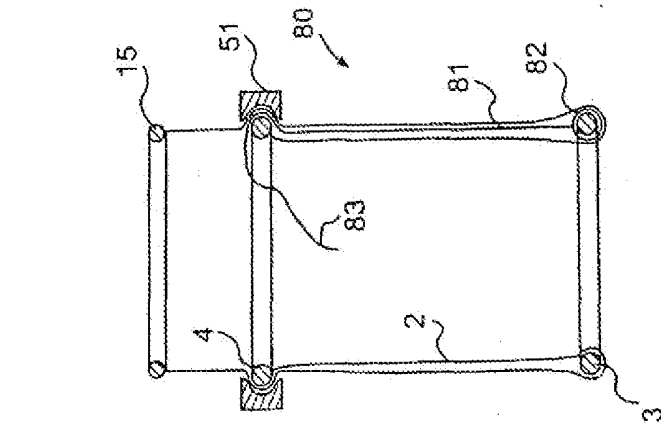
**FIG. 25**



**FIG. 23**



**FIG. 24**



**FIG. 26**

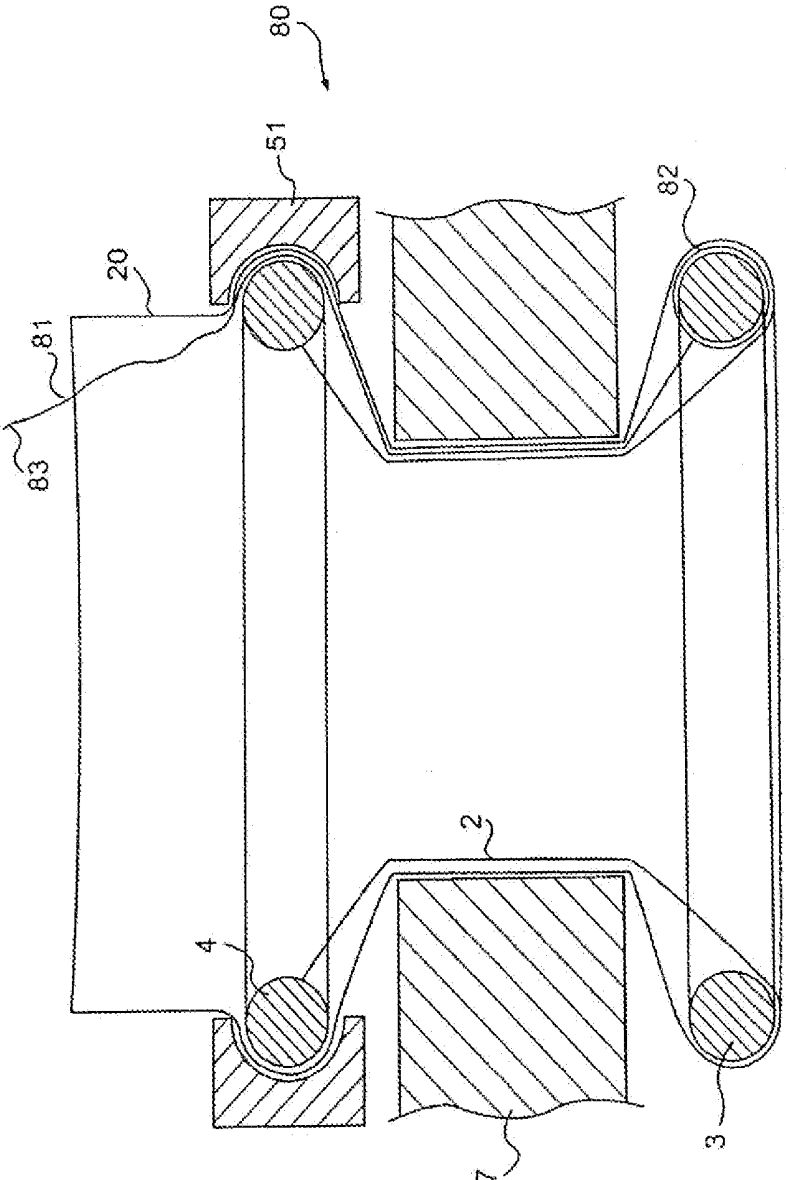
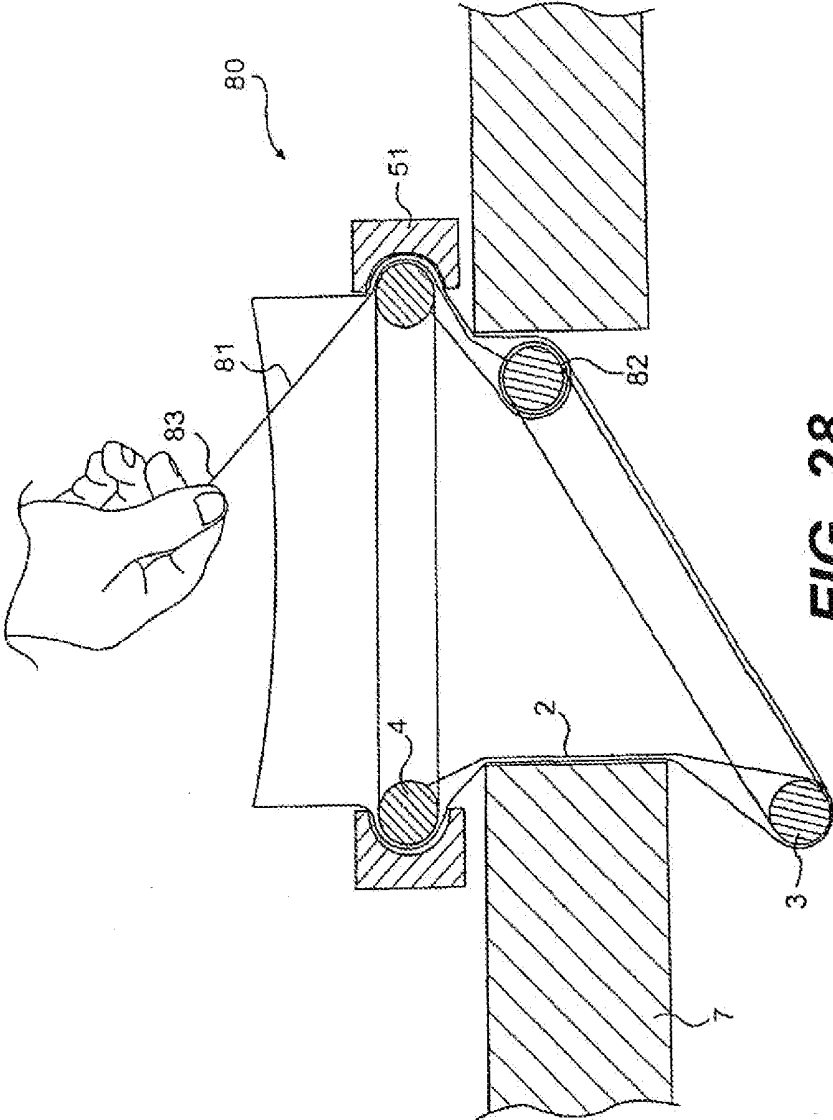
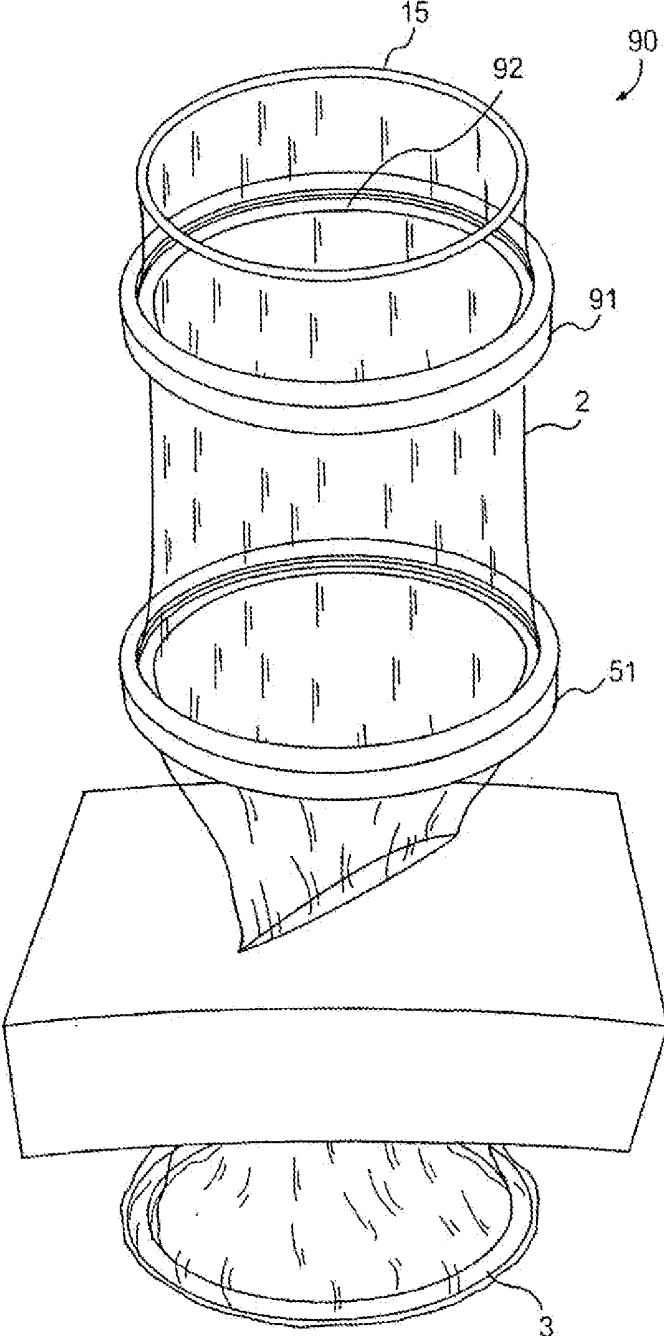


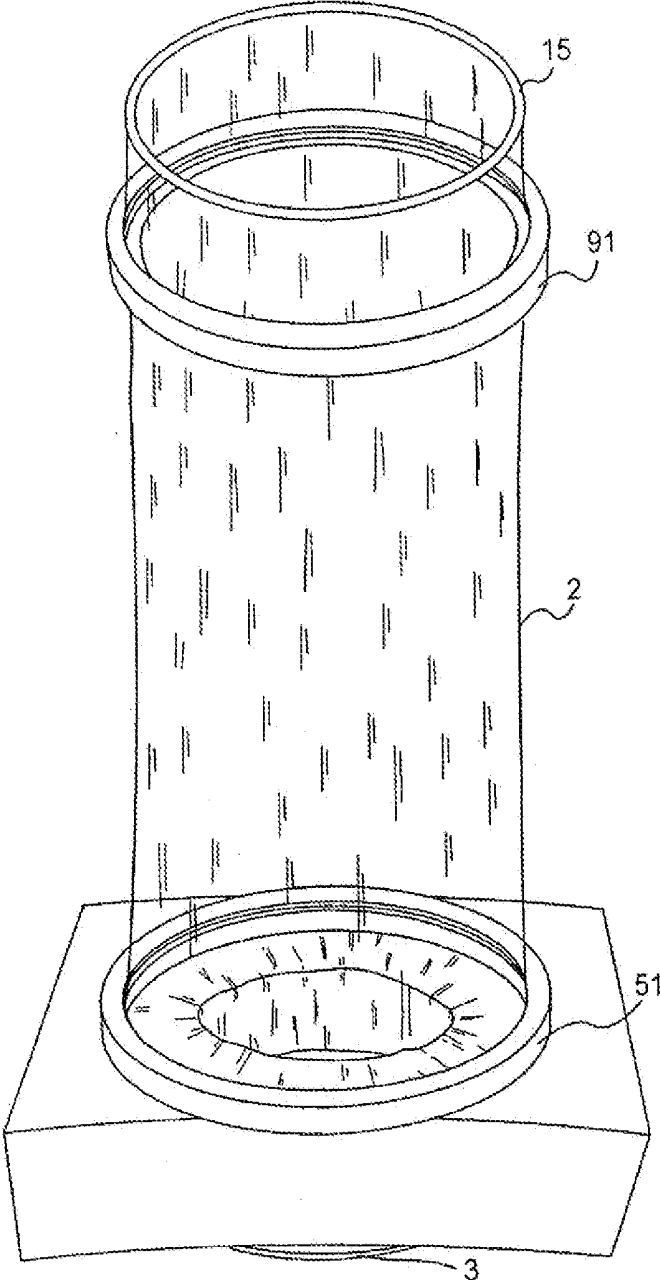
FIG. 27



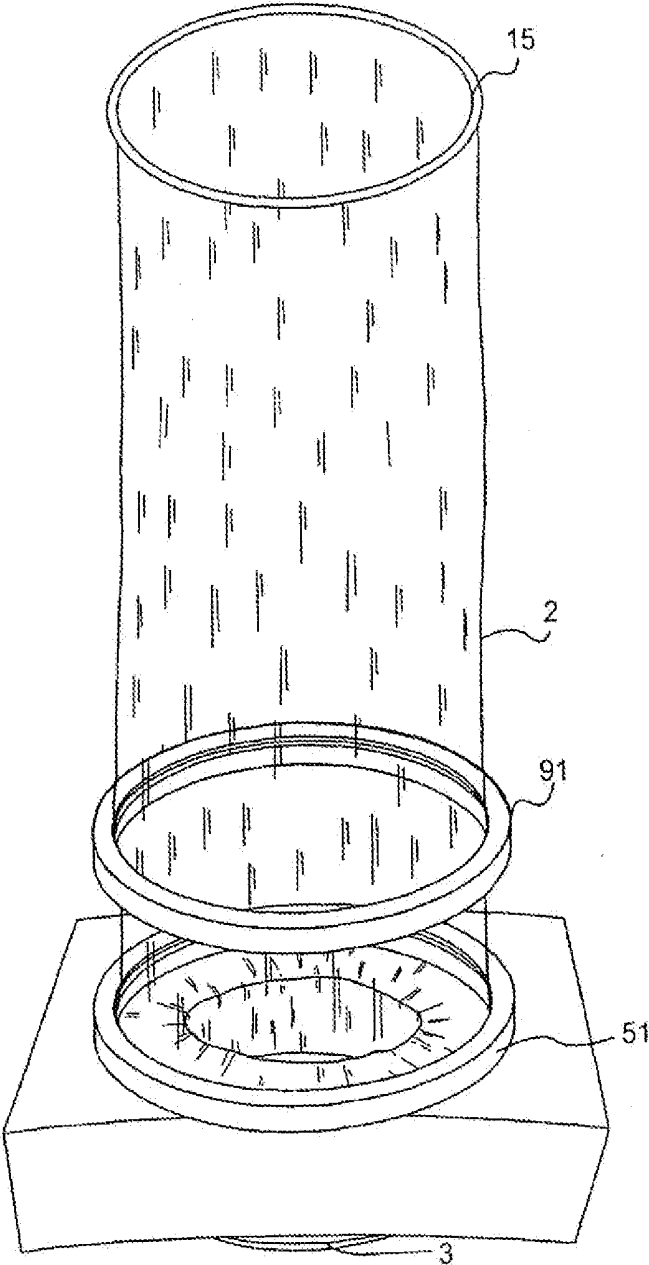
**FIG. 28**



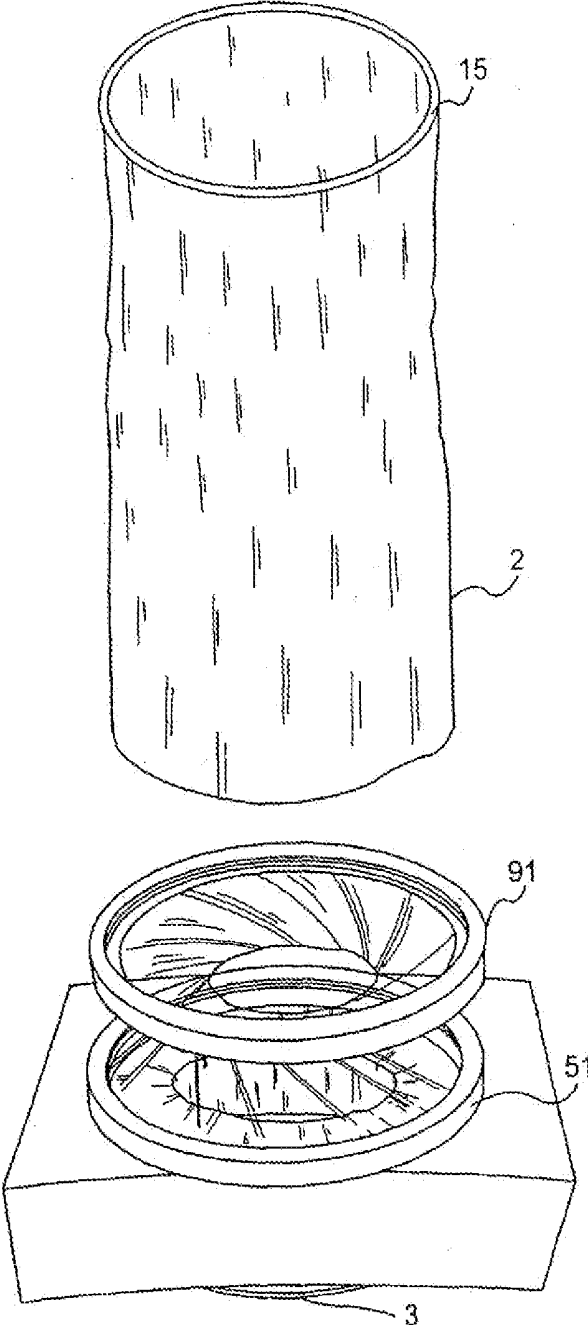
**FIG. 29**



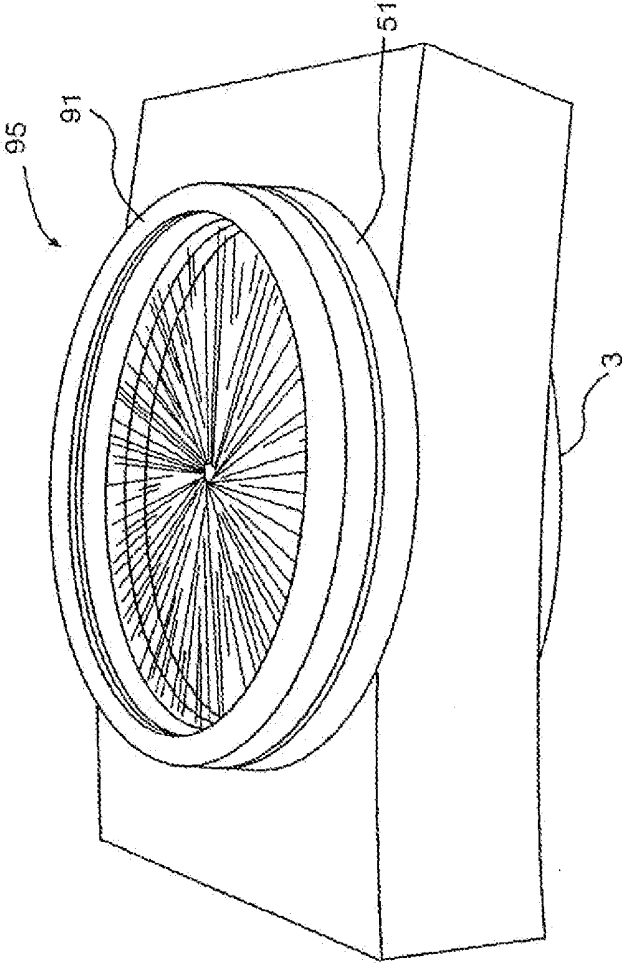
**FIG. 30**



**FIG. 31**



**FIG. 32**



**FIG. 33**

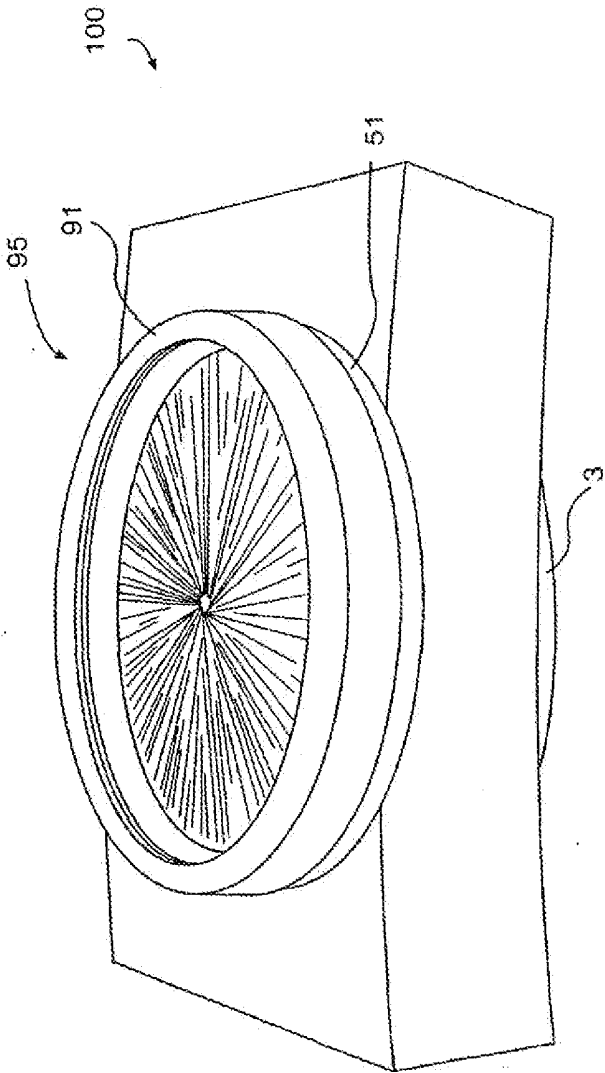


FIG. 34

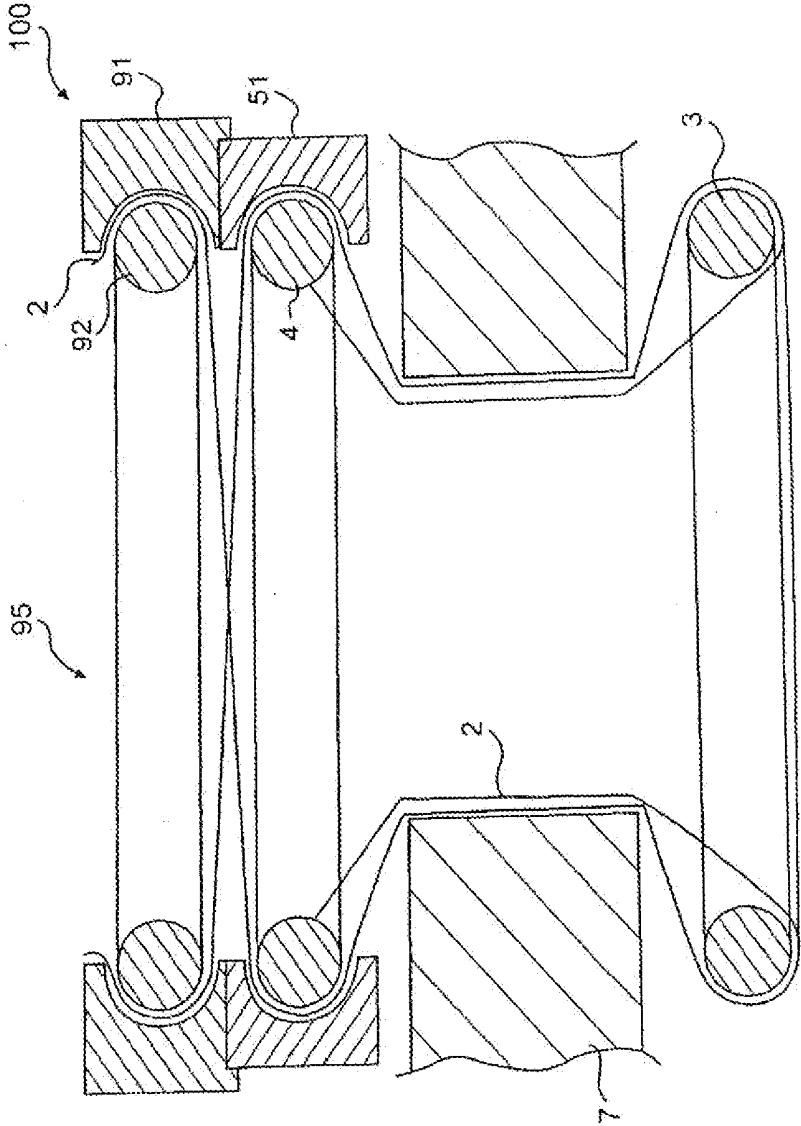
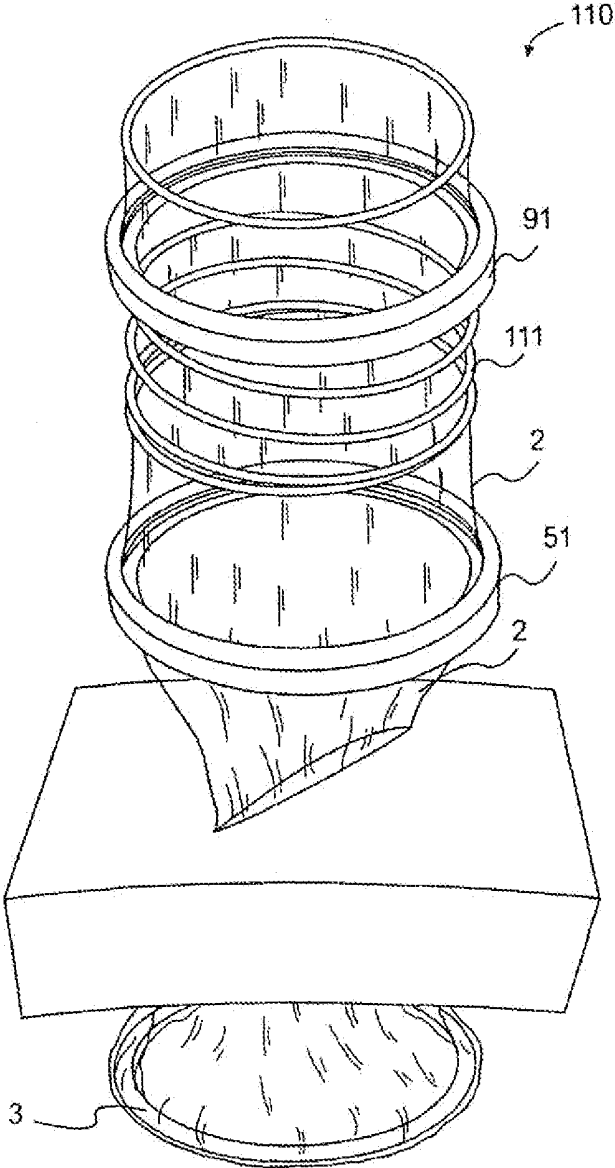
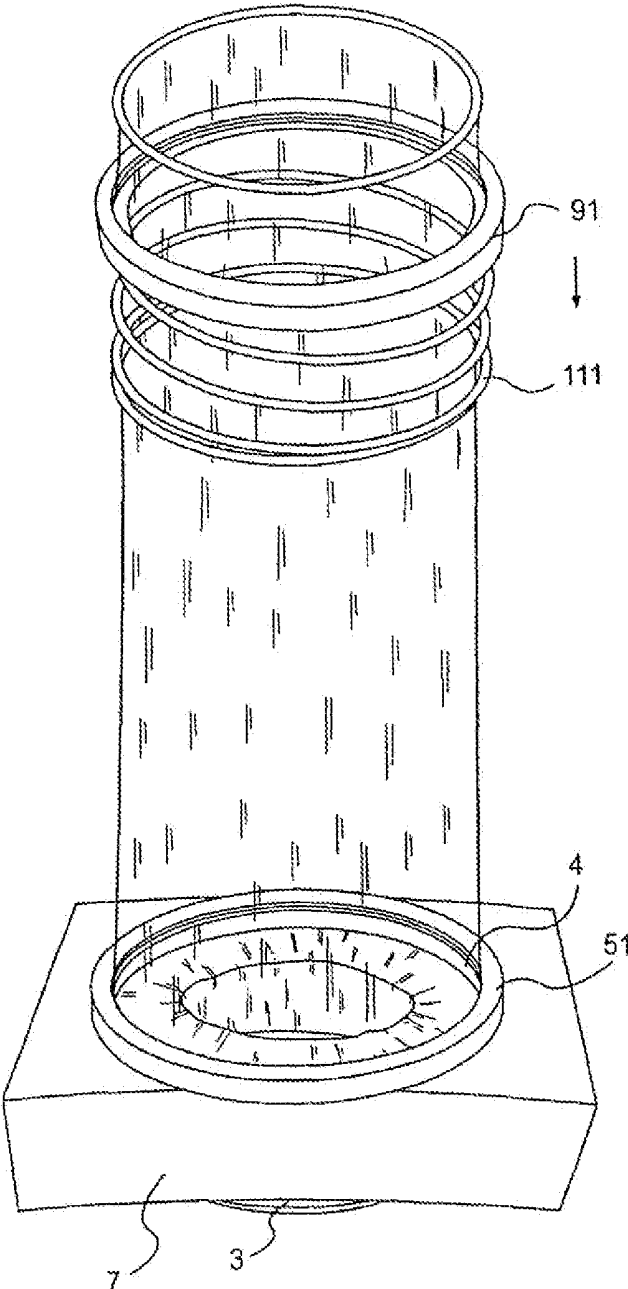


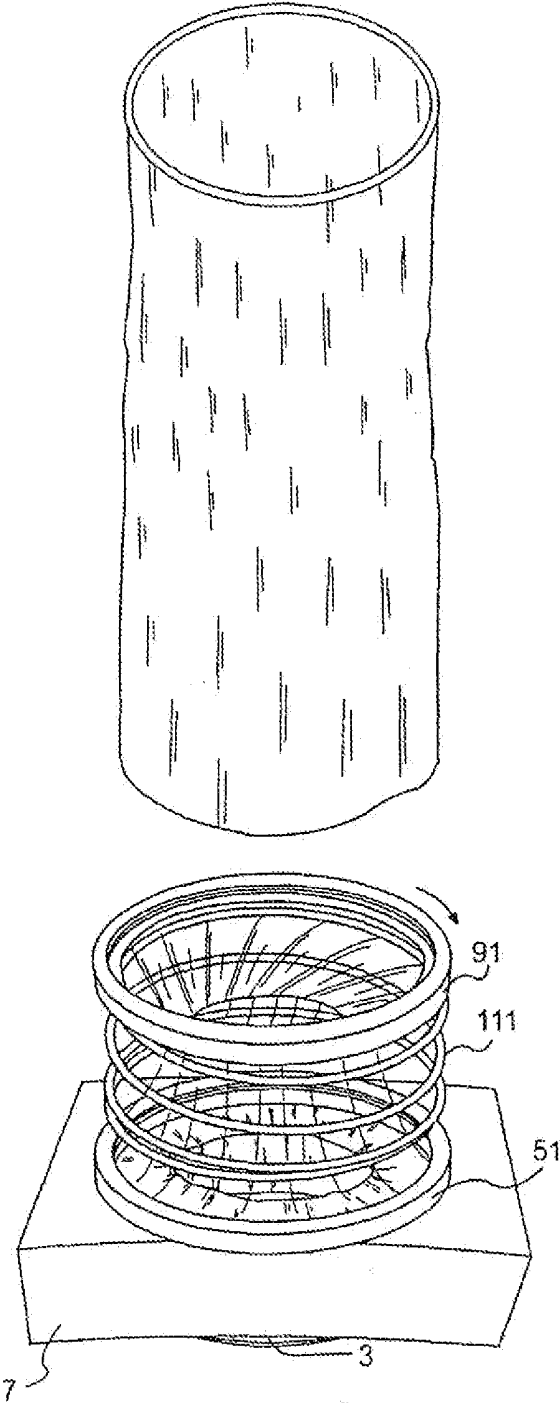
FIG. 35



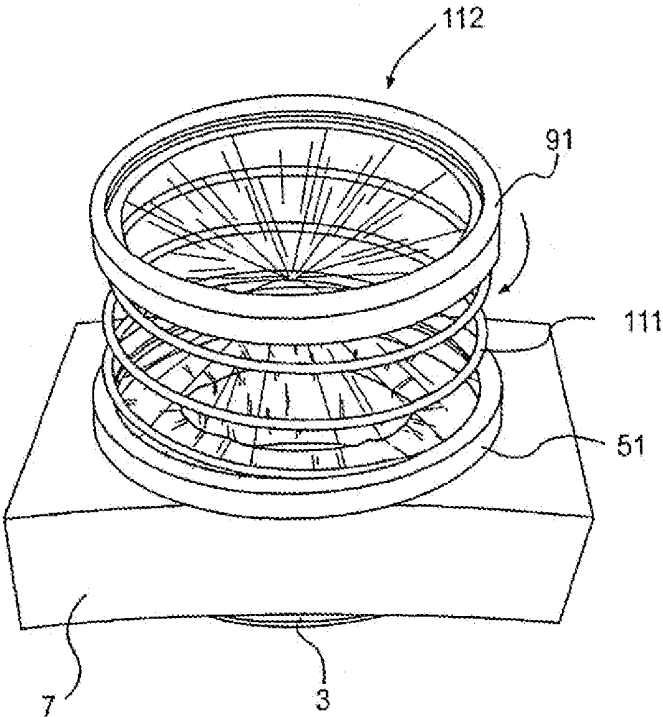
**FIG. 36**



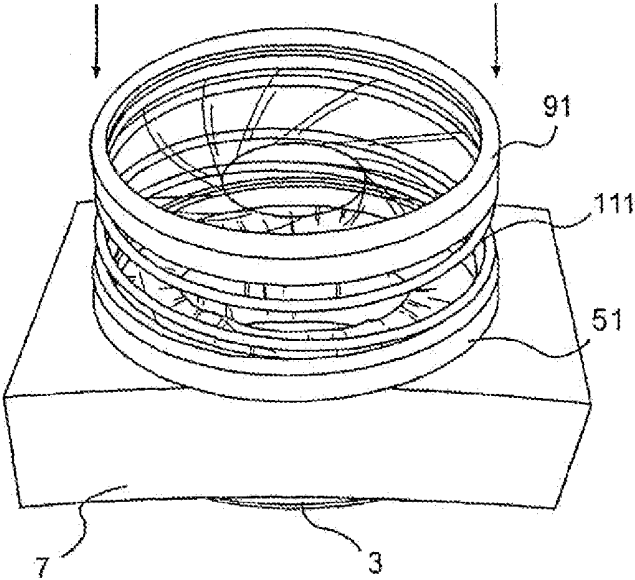
**FIG. 37**



**FIG. 38**



**FIG. 39**



**FIG. 40**

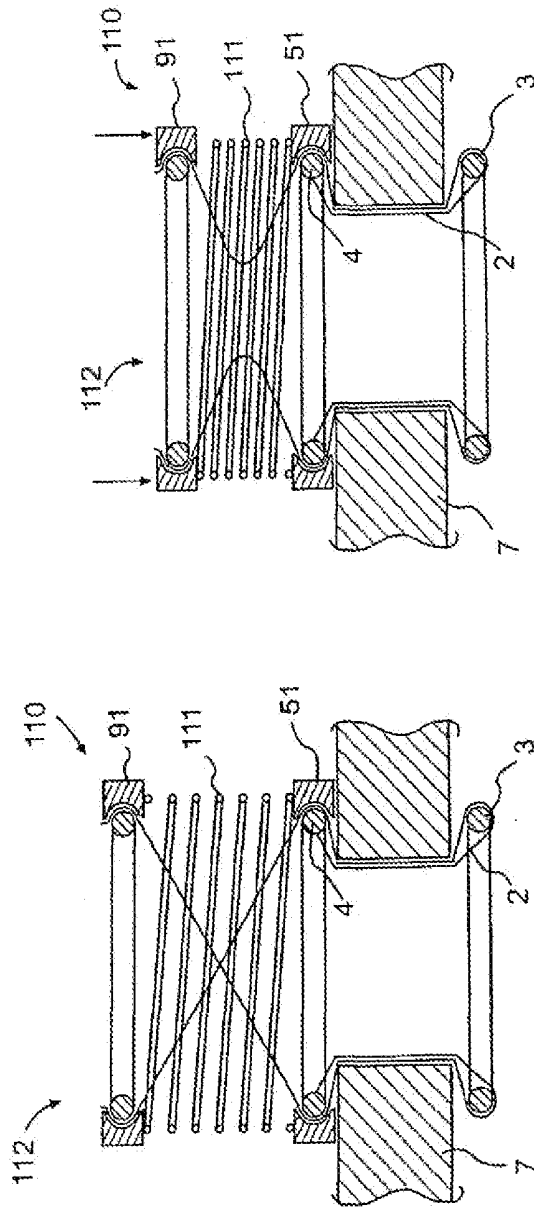


FIG. 41B

FIG. 41A

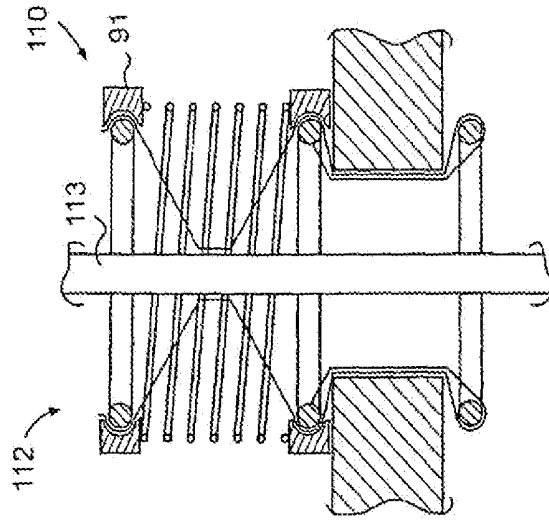


FIG. 41D

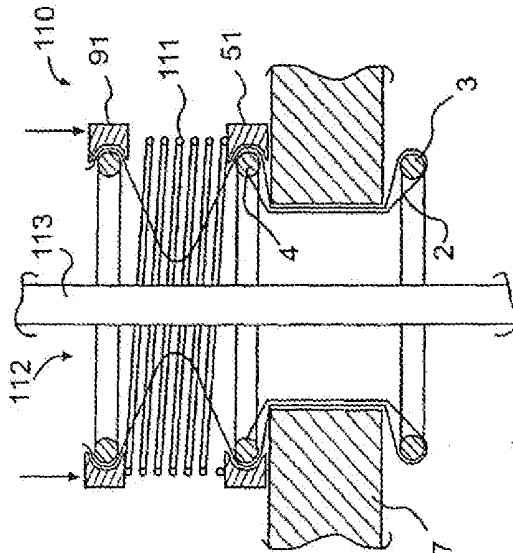


FIG. 41C

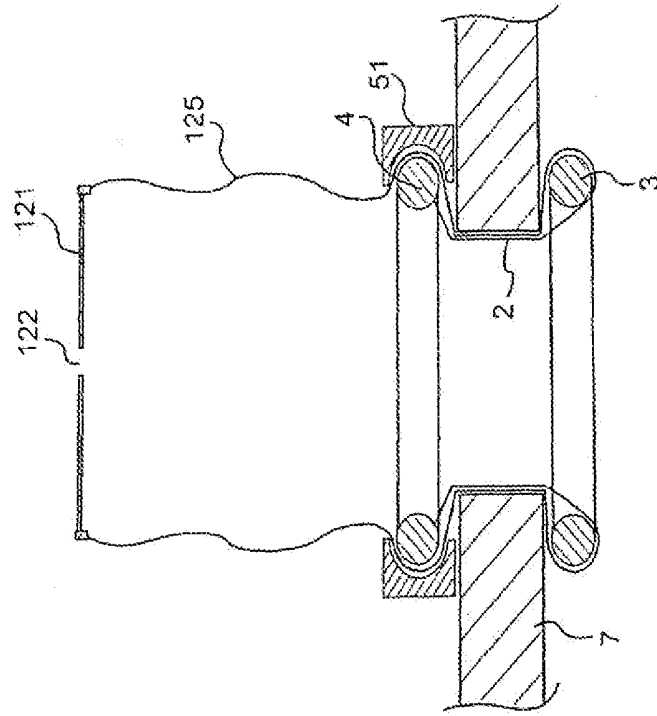


FIG. 43

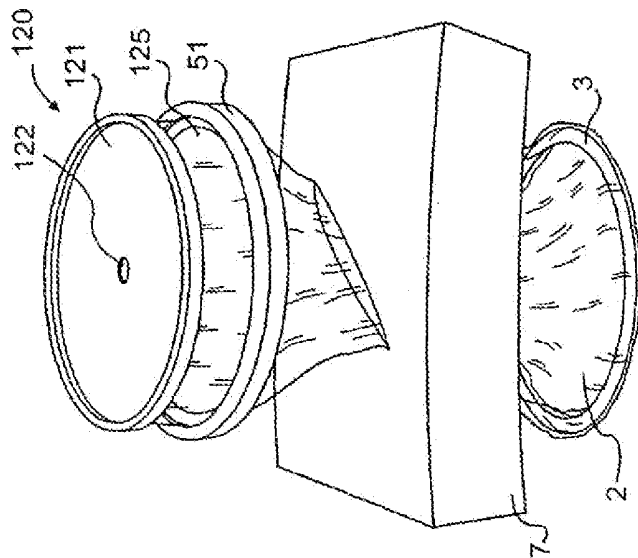


FIG. 42

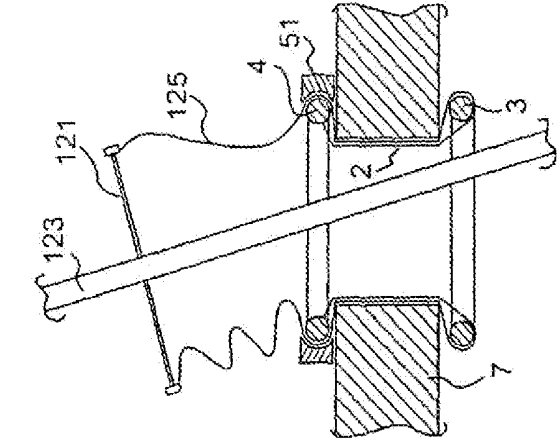


FIG. 44

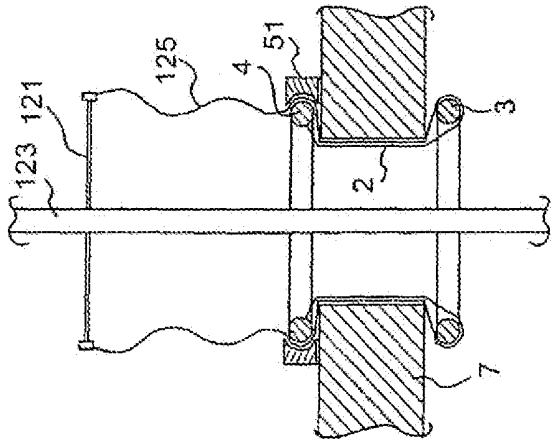


FIG. 45

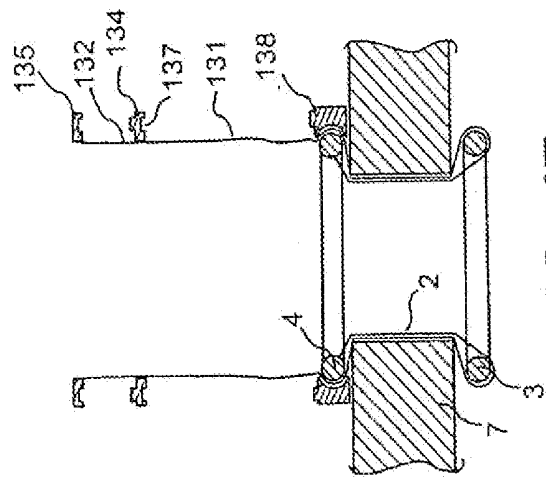


FIG. 47

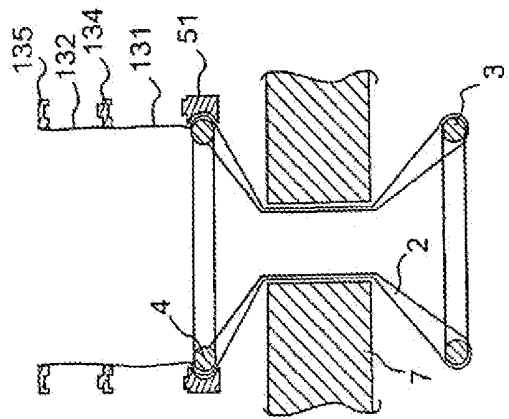


FIG. 46

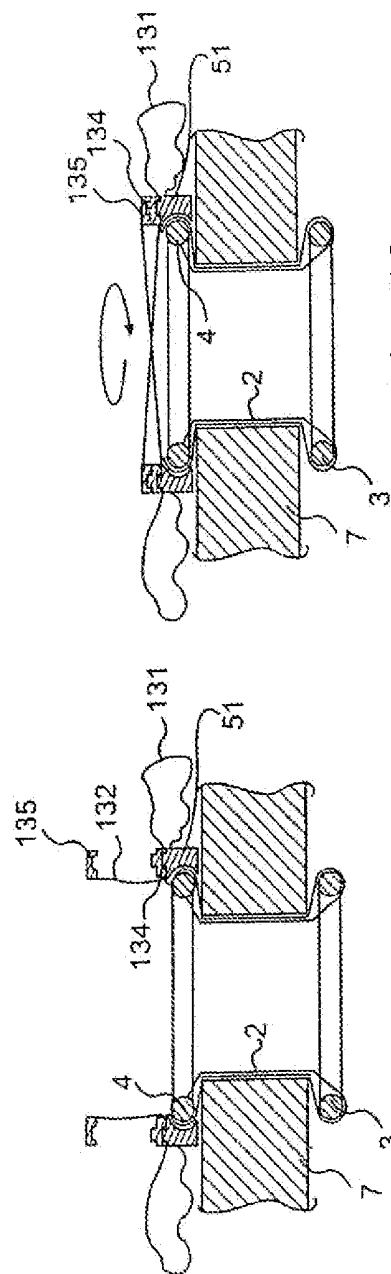
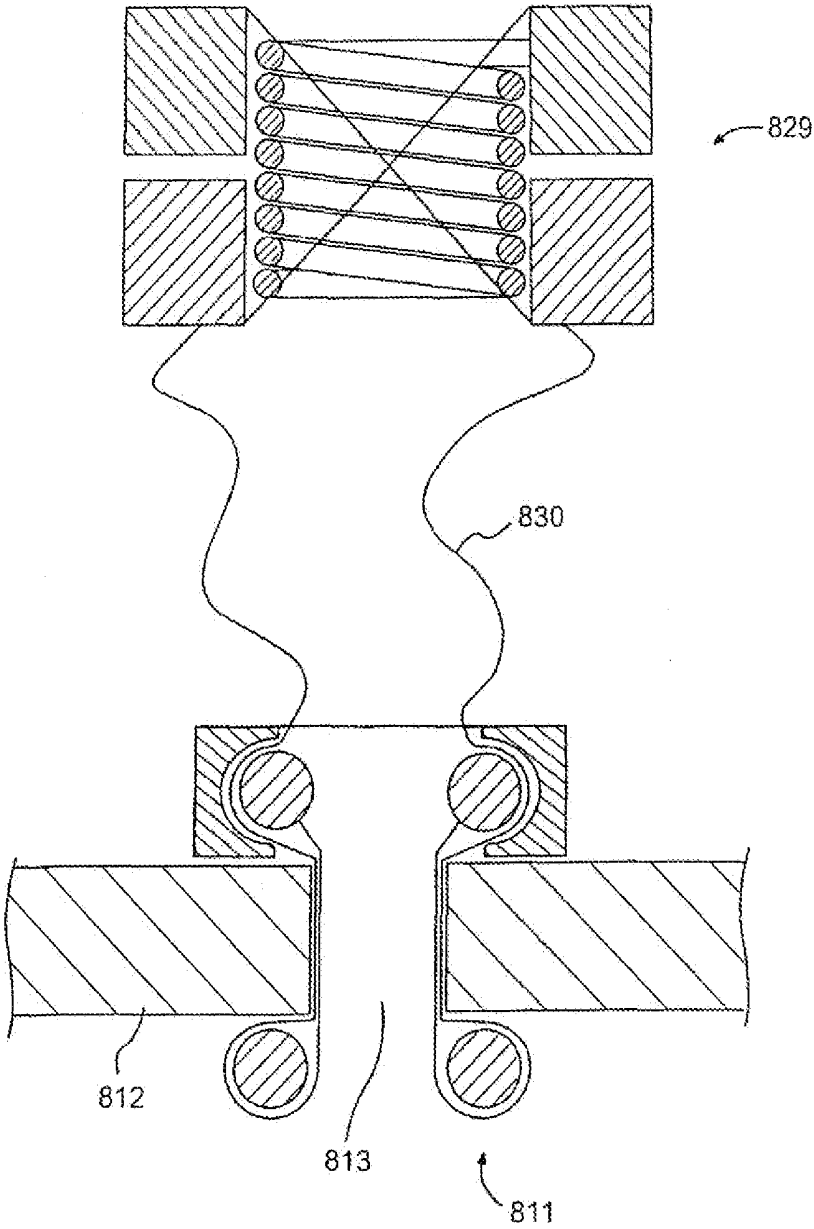
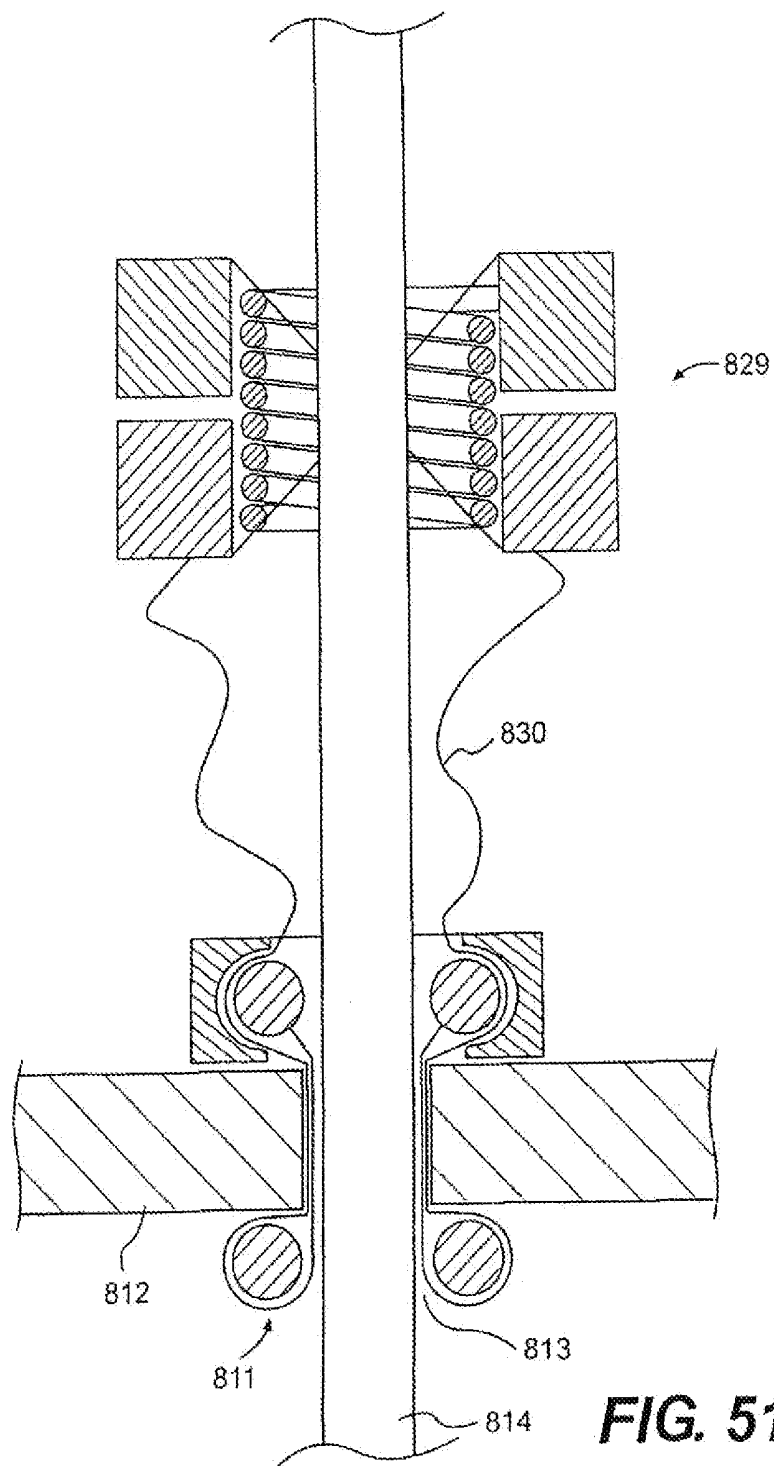


FIG. 49

FIG. 48



**FIG. 50**



**FIG. 51**

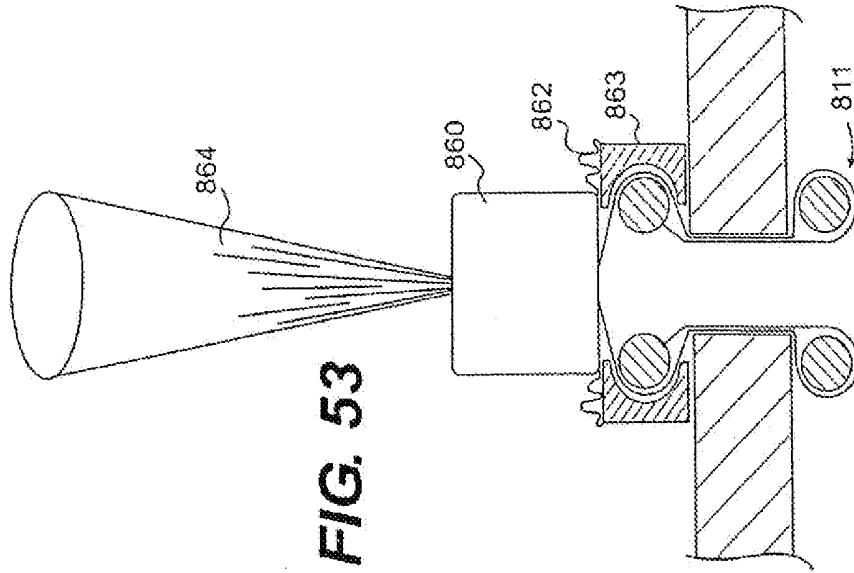


FIG. 53

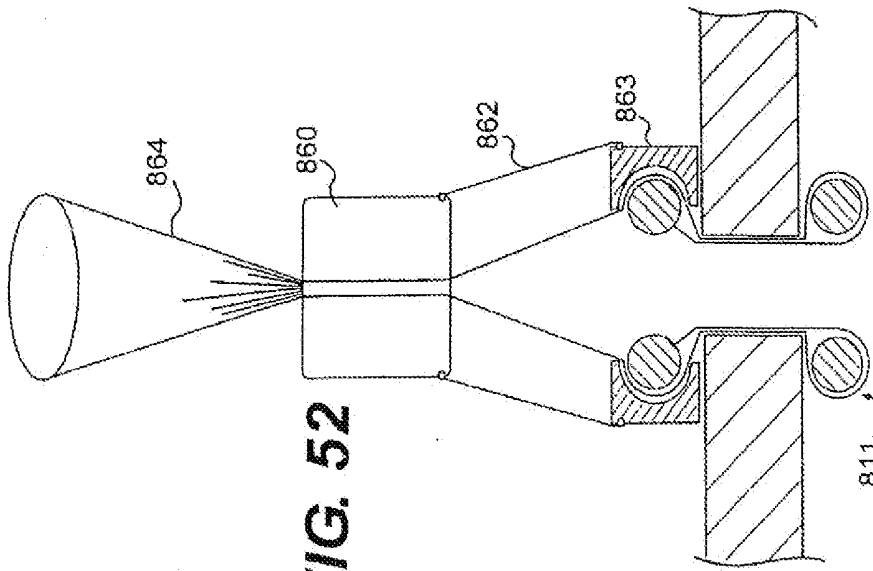
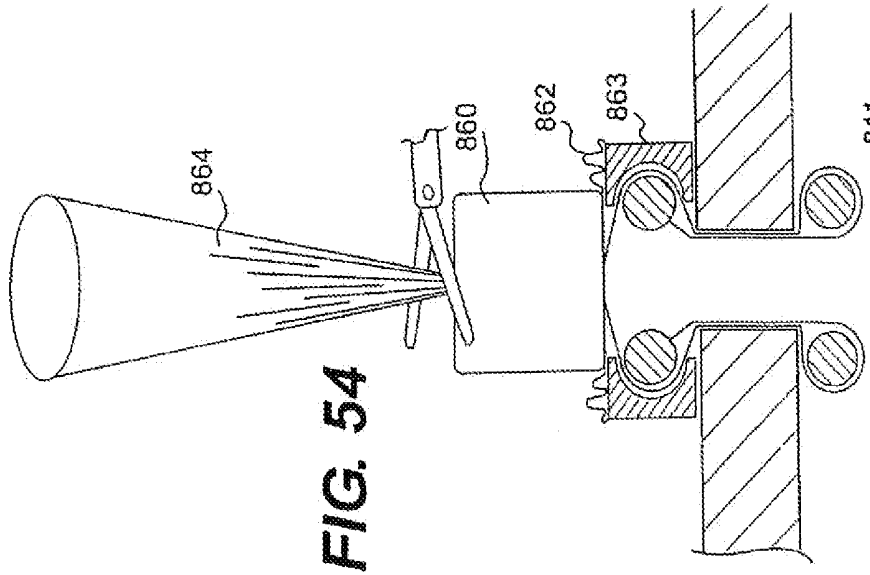
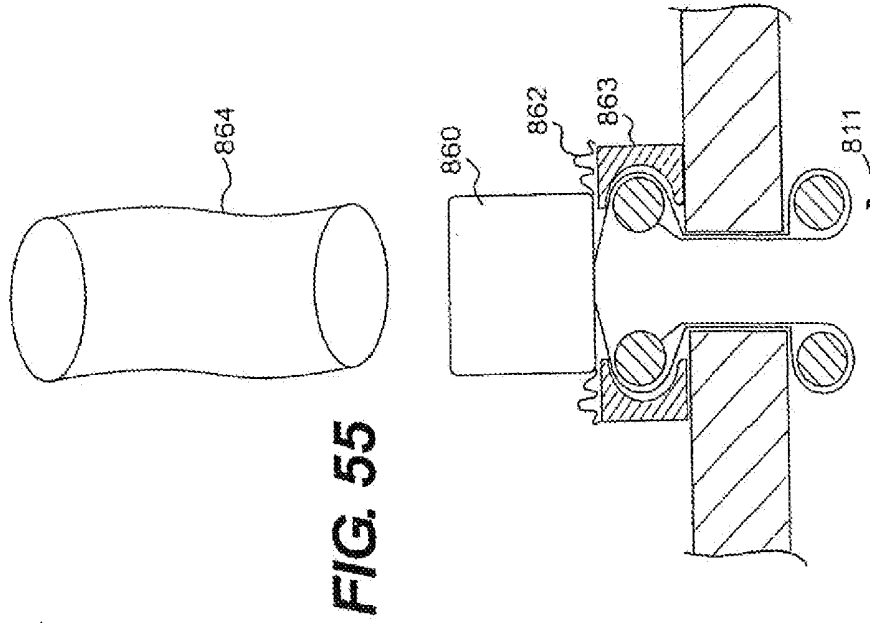


FIG. 52



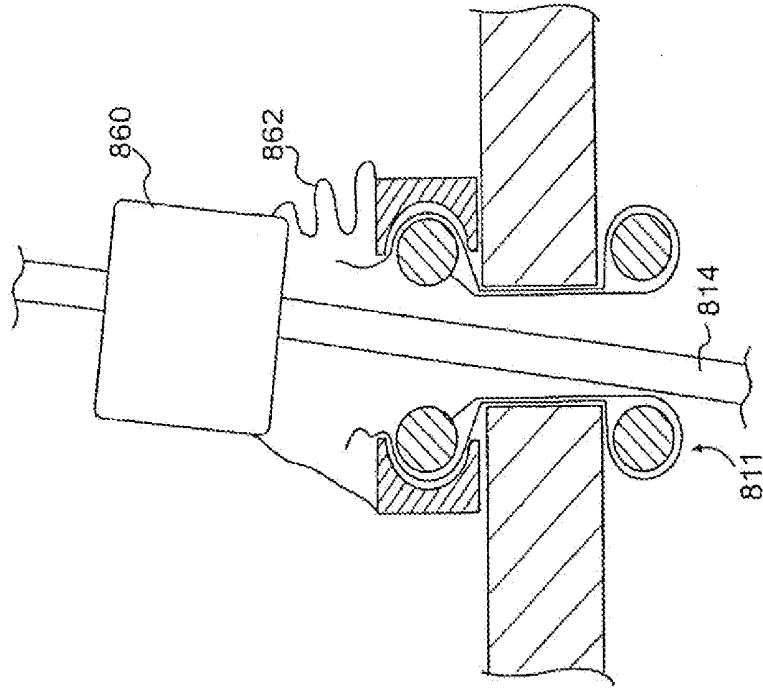


FIG. 57

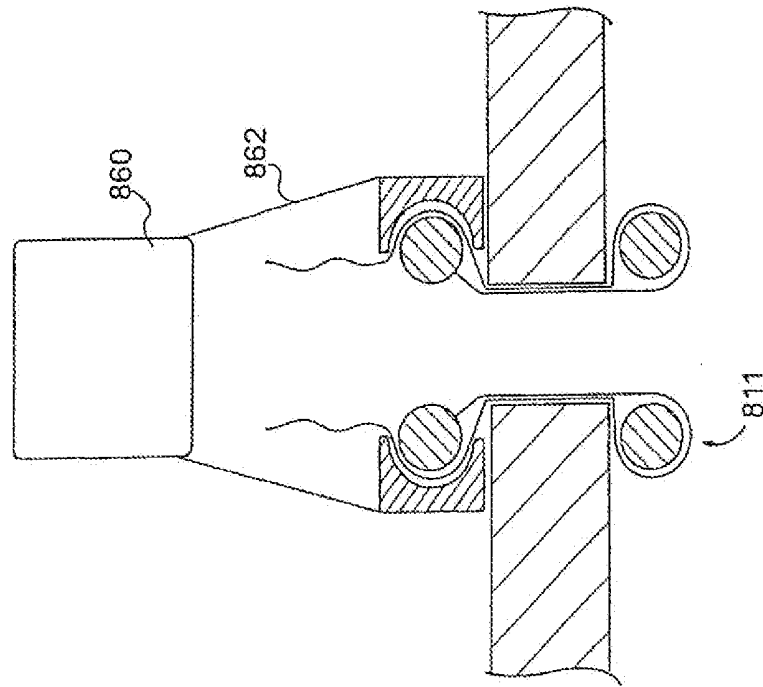


FIG. 56

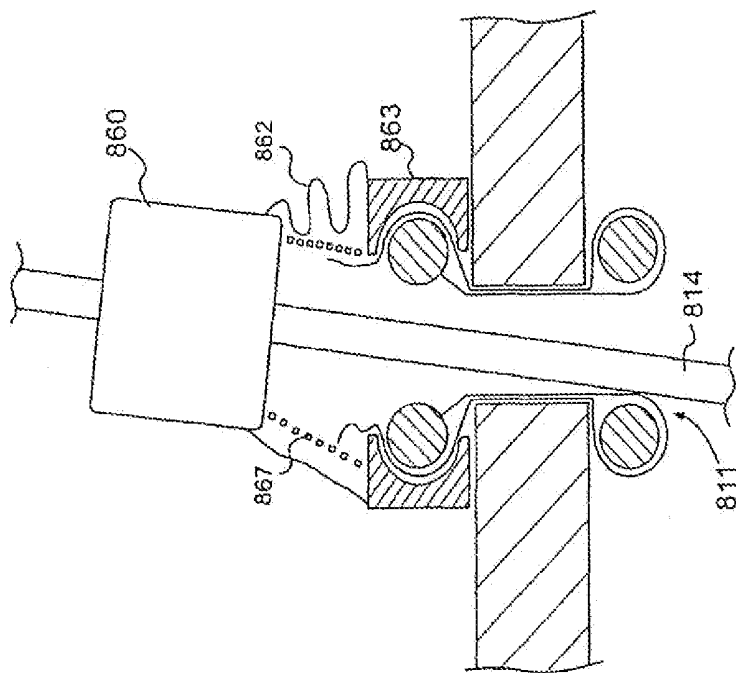


FIG. 58

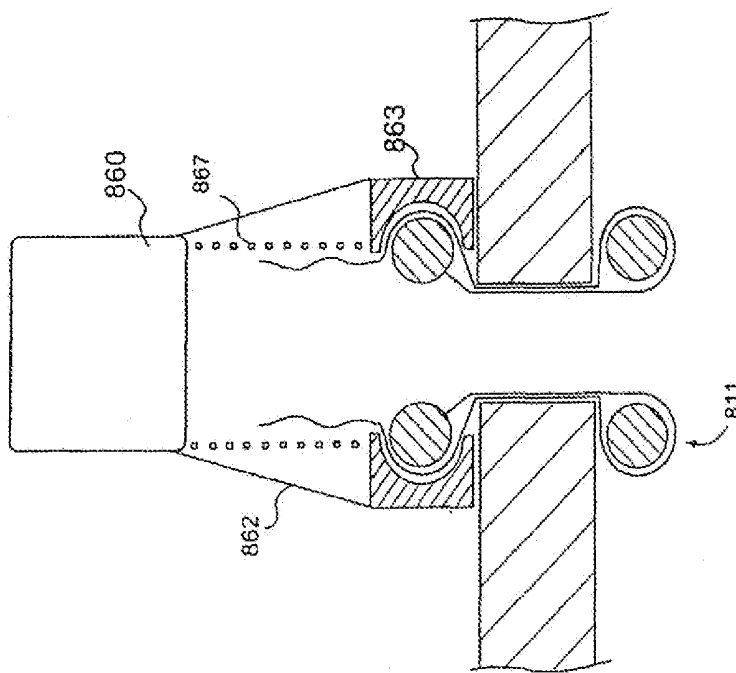


FIG. 59

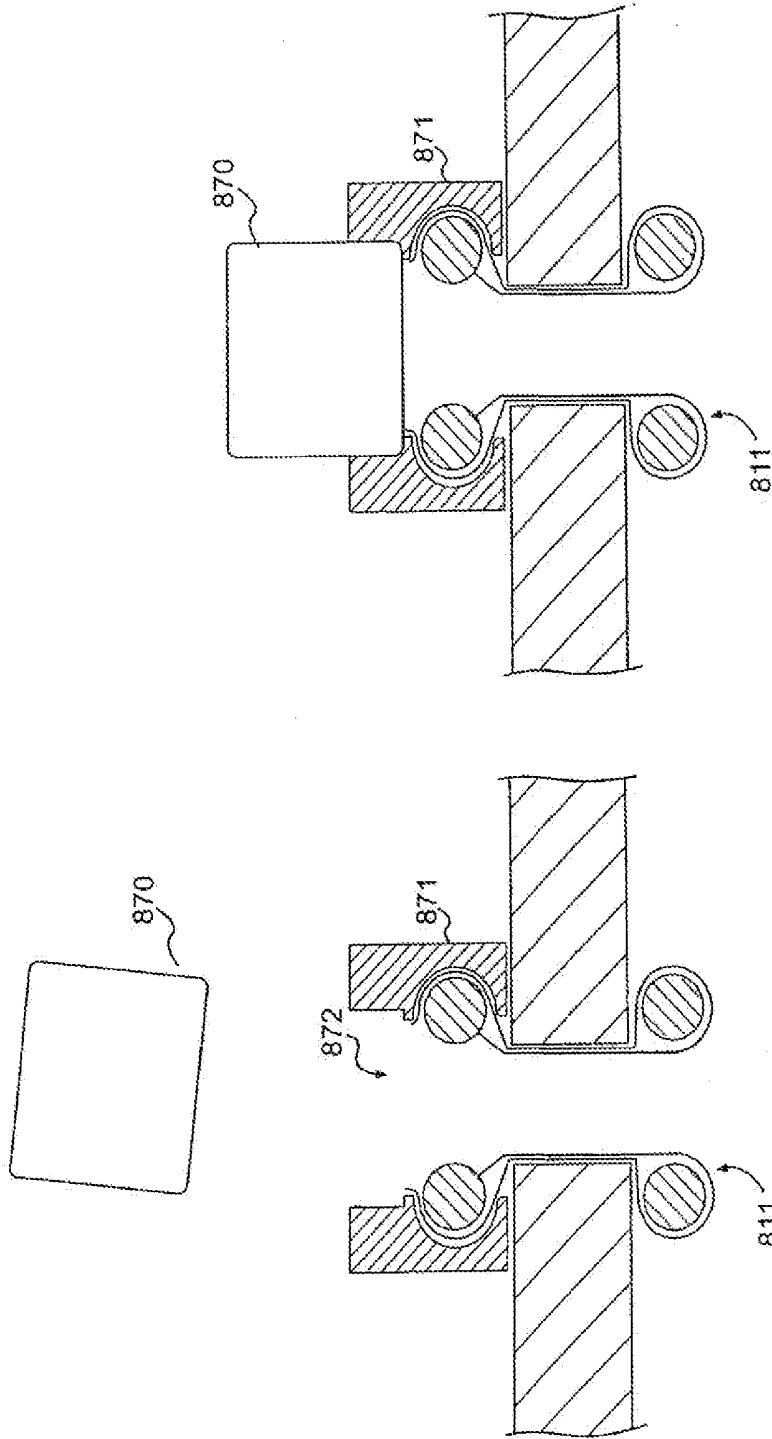
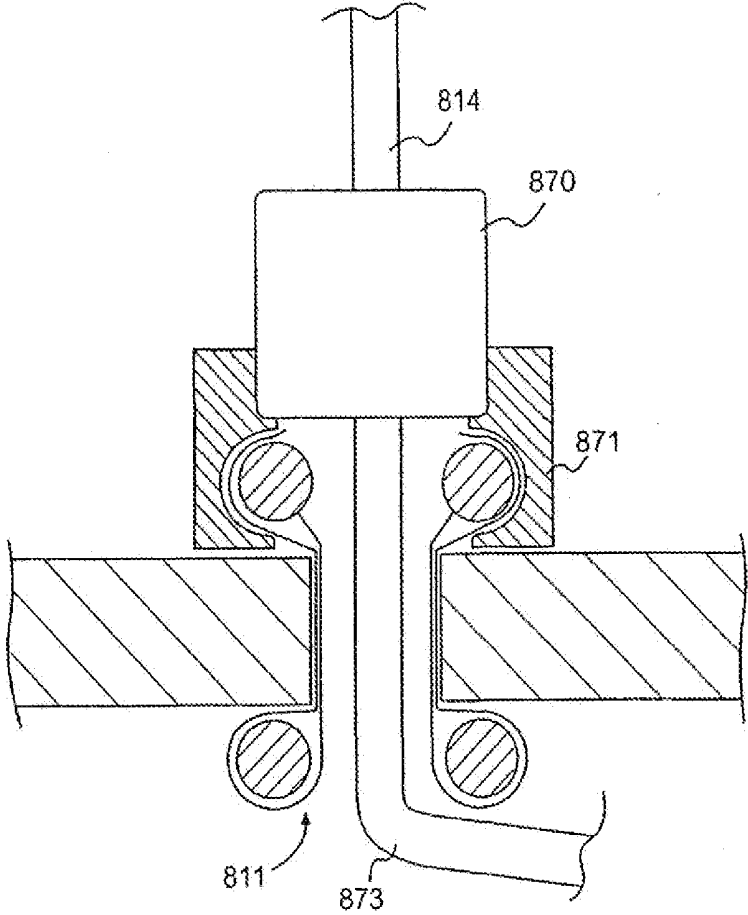
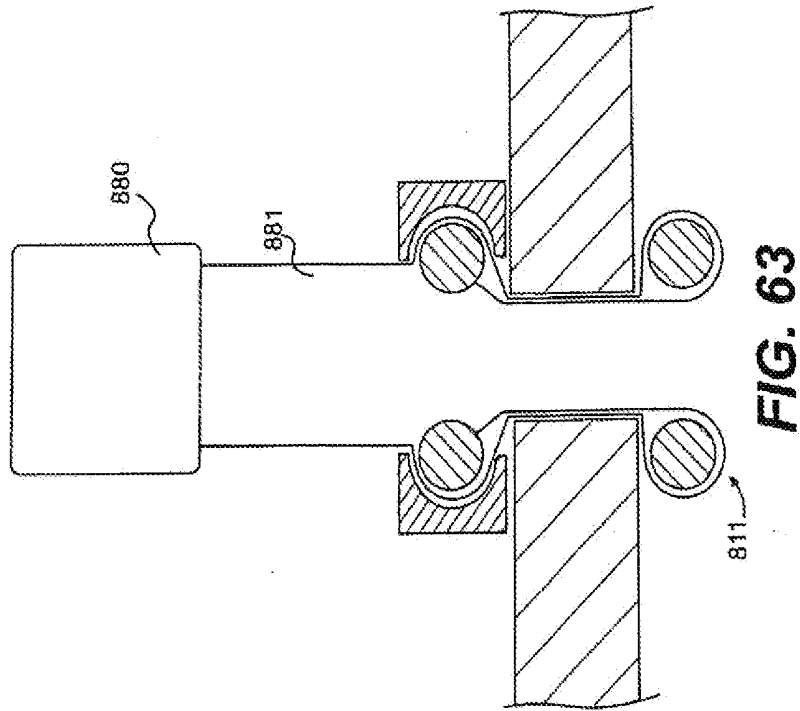
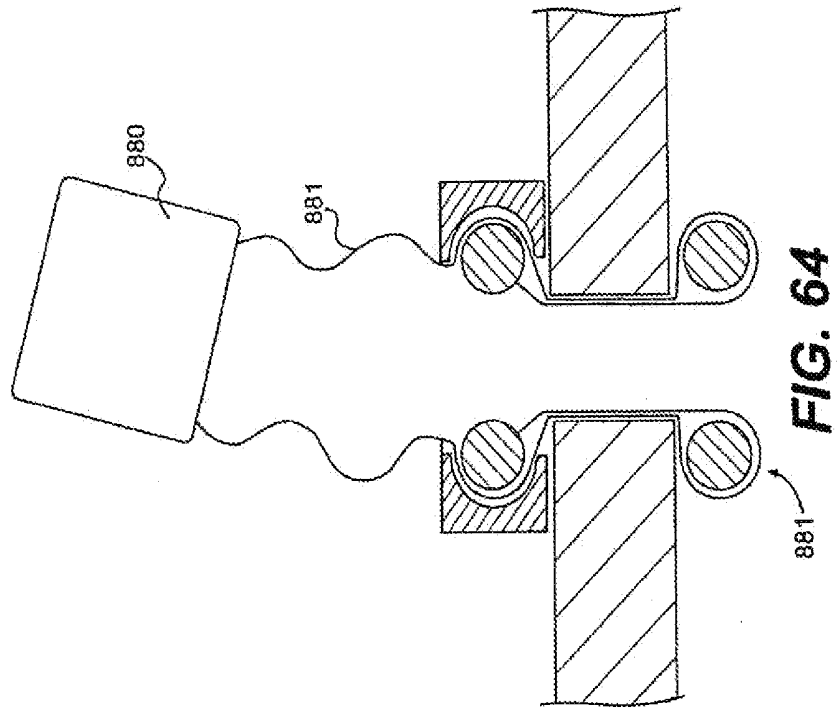


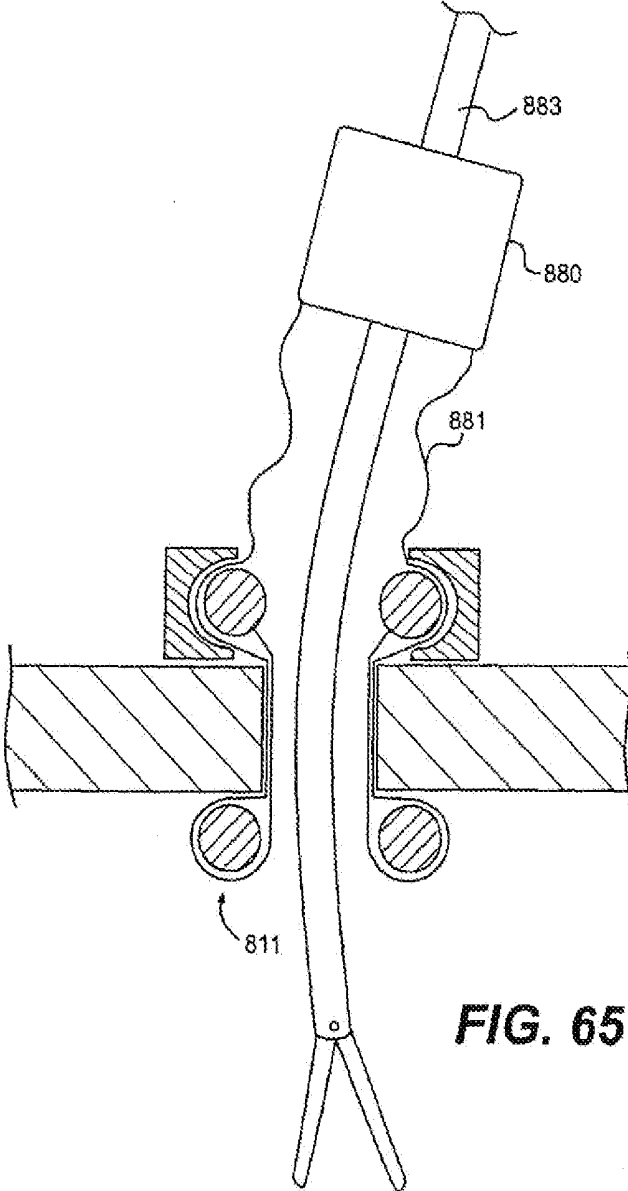
FIG. 61

FIG. 60

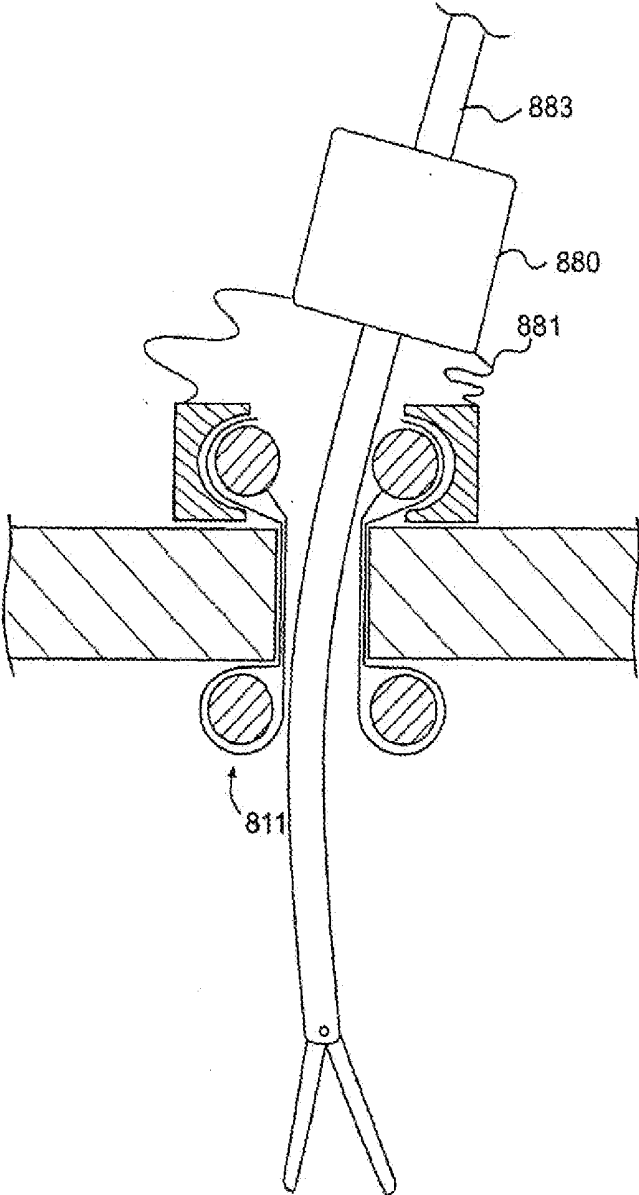


**FIG. 62**

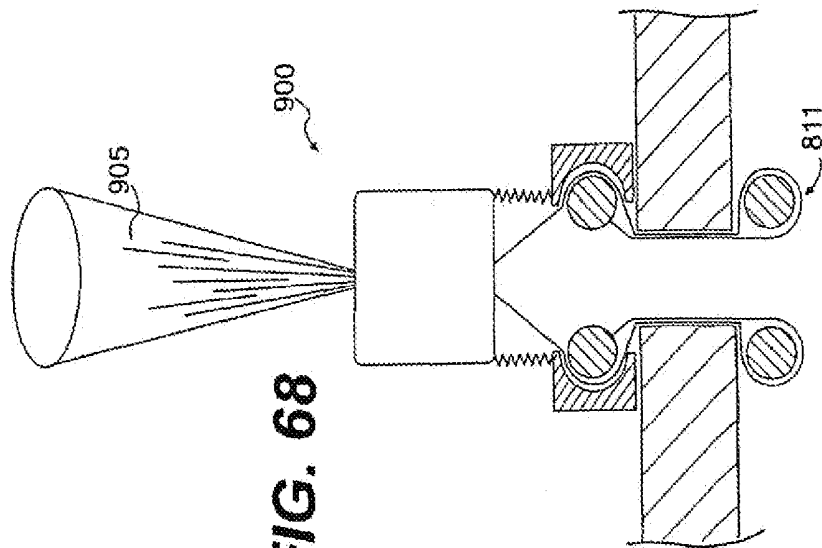




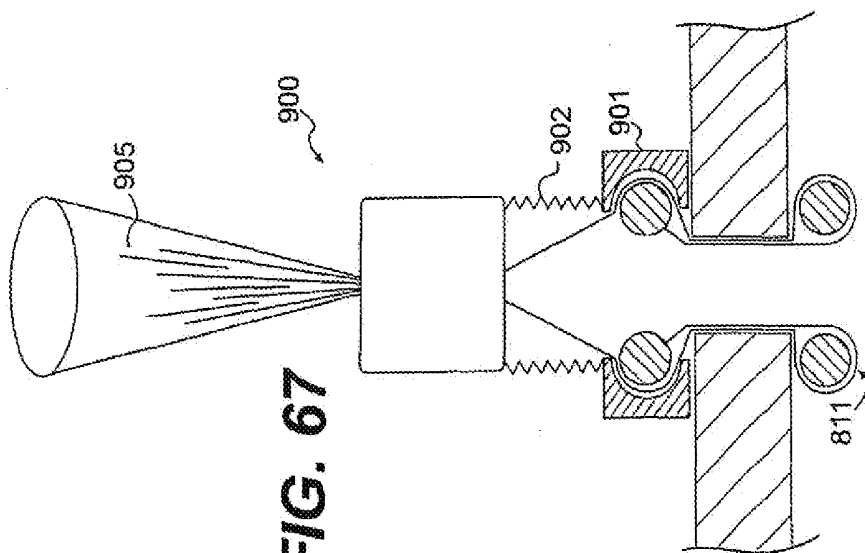
**FIG. 65**



**FIG. 66**



**FIG. 68**



**FIG. 67**

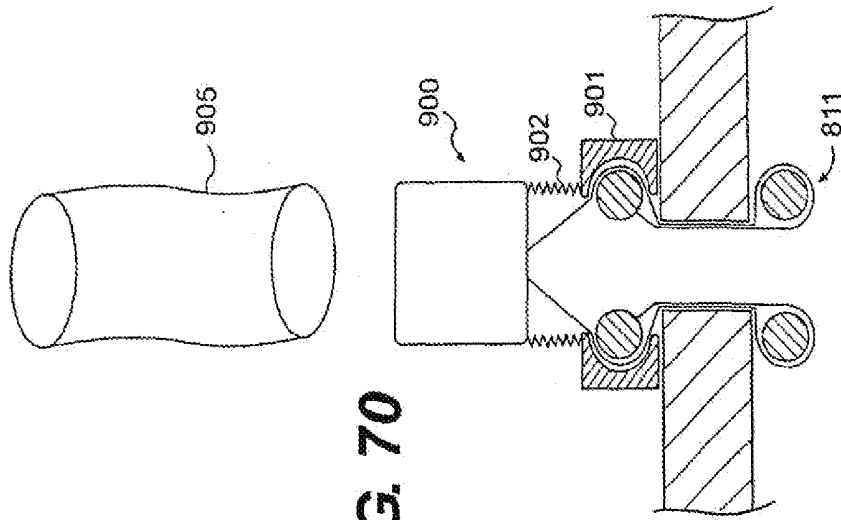


FIG. 69

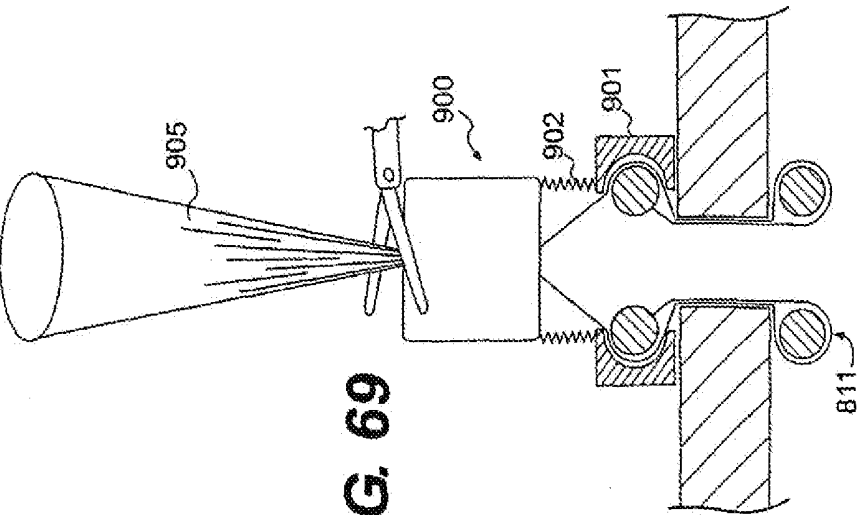
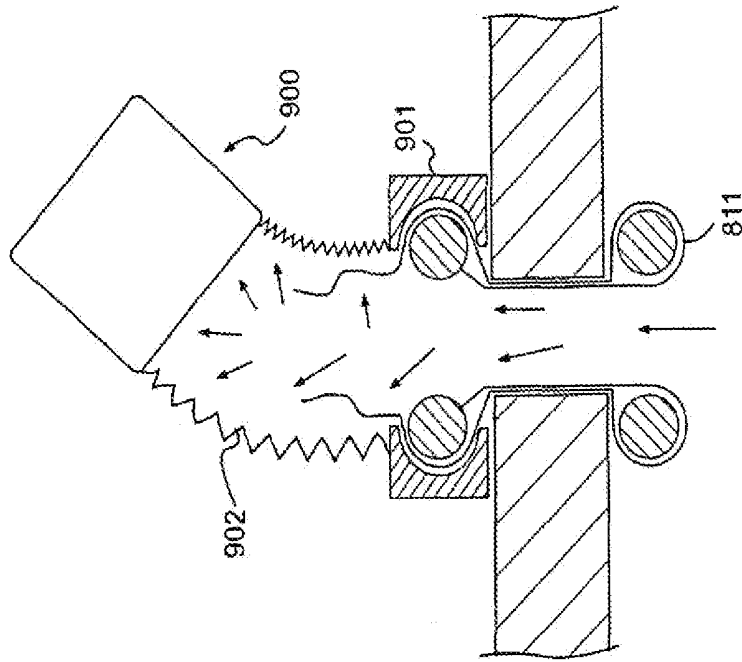
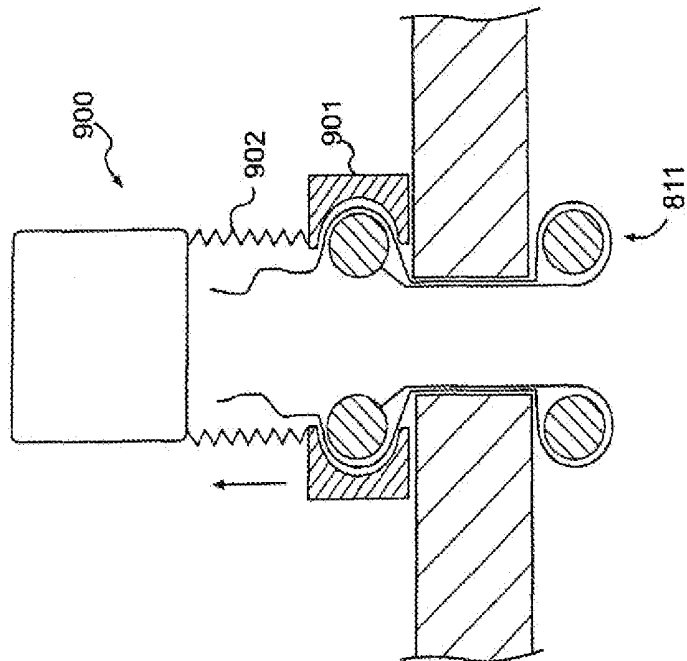


FIG. 70



**FIG. 72**



**FIG. 71**

## WOUND RETRACTOR DEVICE

**[0001]** This application is a Continuation of U.S. application Ser. No. 13/655,286, filed Oct. 18, 2012, which is a Continuation of U.S. application Ser. No. 12/426,438, filed Apr. 20, 2009, now U.S. Pat. No. 8,317,691, which is a Continuation of U.S. application Ser. No. 10/678,653, filed Oct. 6, 2003, now U.S. Pat. No. 7,559,893, which is a Continuation-In-Part of U.S. application Ser. No. 10/133,979, filed Apr. 29, 2002, now U.S. Pat. No. 6,846,287, which is a Continuation of U.S. application Ser. No. 09/801,826, filed Mar. 9, 2001, now abandoned, which is a Continuation of International Application No. PCT/IE99/0022, filed Dec. 1, 1999.

**[0002]** U.S. application Ser. No. 10/678,653 is also a Continuation-In-Part of U.S. application Ser. No. 10/374,523, filed Feb. 27, 2003, now U.S. Pat. No. 7,445,597, which is a Continuation of U.S. application Ser. No. 09/849,341, filed May 7, 2001, now U.S. Pat. No. 6,582,364, which is a Continuation of U.S. application Ser. No. 09/688,138, filed Oct. 16, 2000, now U.S. Pat. No. 6,254,534.

**[0003]** U.S. application Ser. No. 10/678,653 also claims benefits of priority of U.S. Provisional Application No. 60/415,780, filed Oct. 4, 2002, 60/428,215, filed Nov. 22, 2002, and U.S. Provisional Application No. 60/490,909, filed Jul. 30, 2003.

**[0004]** U.S. application Ser. No. 09/688,138 also claims the benefits of priority of European Application No. 00650010, filed Feb. 18, 2000, Application No. 991053, filed Dec. 16, 1999, in Ireland, Application No. 990861, filed Oct. 14, 1999, in Ireland.

**[0005]** International Application No. PCT/IE99/0022 also claims the benefits of priority of Application No. 990111, filed Feb. 15, 1999, in Ireland, and Application No. 980997, filed Dec. 1, 1998, in Ireland.

**[0006]** All of the above-listed applications are incorporated herein by reference in their entireties.

## INTRODUCTION

**[0007]** The invention relates to a retractor. In particular the invention relates to a retractor for retracting the margins of an incision or a natural bodily orifice to provide maximum exposure of an organ or body structures for examination and/or access for surgical procedures, while also providing protection for the exposed sides of the incised tissue.

**[0008]** Various retractors are known. Some known retractors are difficult and cumbersome to use, and/or are relatively expensive. In addition, some known retractors are limited to use with a particular size of incision and a particular patient anatomy.

**[0009]** This invention is directed towards providing an improved wound retractor which will overcome at least some of these problems, and in addition provide a means of wound protection during a surgical procedure.

## STATEMENTS OF INVENTION

**[0010]** According to the invention there is provided a wound protector and retractor device comprising:

**[0011]** a longitudinal axis;

**[0012]** a distal member;

**[0013]** a proximal member; and

**[0014]** a sleeve extending at least between the distal member and the proximal member,

**[0015]** the sleeve having a proximal gripping portion for pulling the sleeve upwardly to shorten an axial extent located between the distal member and the proximal member.

**[0016]** In the device, on release of the gripping portion the shortened axial extent between the distal member and the proximal member is substantially maintained without a requirement for an additional locking device.

**[0017]** In one embodiment the proximal gripping portion is provided at a proximal end portion of the sleeve. The gripping portion may be reinforced by a reinforcing arrangement such as a gripping ring. The gripping ring may be mounted to the sleeve.

**[0018]** In one embodiment the sleeve is fixed to the proximal member at a first end portion and is movable over the proximal member at a second end portion. The sleeve may be axially slidable over the proximal member at the second end portion.

**[0019]** In another embodiment the second end portion of the sleeve is slidingly received over a portion of the proximal member to allow relative movement between the sleeve and the proximal member to shorten the axial extent of the sleeve located between the distal member and the proximal member. The portion of the proximal member that slidingly receives the sleeve may include an outer portion of the proximal member. The second end portion of the sleeve may be biased against the proximal member.

**[0020]** In one embodiment the proximal member is located within the sleeve.

**[0021]** The proximal member may form a part of a securing arrangement configured to substantially fix the axial extent of the sleeve located between the distal member and the proximal member at a desired length.

**[0022]** The sleeve may extend from the proximal member, around the distal member, and has a return section outside of the proximal member, the return section providing the proximal gripping portion.

**[0023]** In one embodiment the distal member comprises a distal ring which may be an O-ring.

**[0024]** The distal ring may be formed of an elastomeric material.

**[0025]** In one embodiment the proximal member comprises a proximal ring which may be an O-ring.

**[0026]** The proximal ring may be relatively rigid with respect to the distal ring.

**[0027]** In one embodiment the sleeve is of a pliable material.

**[0028]** The wound protector and retractor device may comprise a guide member for a proximal portion of the sleeve.

**[0029]** The sleeve may extend between the guide member and the proximal member.

**[0030]** The guide member may comprise a receiver for the proximal member. For example, the guide member may have an inwardly facing recess defining a receiver for the proximal member. In one case the proximal member comprises a proximal ring and the recess has a shape which is complementary to that of the proximal ring, for example the recess may be substantially C-shaped in transverse cross section.

**[0031]** In another embodiment a lock may be provided for locking the guide member to the proximal member. The guide member may be engagable with the proximal member to provide the lock.

**[0032]** In some cases the guide member may be an interference fit with the proximal member.

[0033] In one embodiment, on retraction of an incision the sleeve defines an excess sleeve portion extending between the proximal member and the gripping portion.

[0034] The excess sleeve portion may be removed. Alternatively the excess sleeve portion is inserted through the retractor and in this case may define an organ retainer.

[0035] Alternatively the excess sleeve portion is configured to form a seal such as a forearm seal or an instrument seal.

[0036] The seal may comprise an iris valve.

[0037] In one embodiment the device comprises a guide member for a proximal portion of the sleeve and the excess sleeve material is mounted to the guide member. The excess sleeve material together with the guide member may define a chamber. The chamber may have an inflation port. In one case, on inflation, the chamber defines a seal for an object such as a surgeon's forearm or an instrument shaft.

[0038] In one embodiment the device comprises a first proximal mounting member and a second proximal mounting member between which at least portion of a sleeve extends. The first and second mounting members may be movable relative to one another.

[0039] The mounting members may be movable axially relative to one another and/or the mounting members are rotationally movable relative to one another.

[0040] In one arrangement the mounting members are movable relative to one another to configure at least portion of the proximal portion of the sleeve to form a seal. The mounting members may be movable to twist the sleeve to form an iris.

[0041] In one embodiment the device comprises a biasing member for biasing the seal into a desired configuration such as a closed configuration.

[0042] The biasing member may be a spring such as a coil spring.

[0043] In one embodiment the device further comprises a lock for locking the first and second mounting members together.

[0044] The second mounting member may be engagable with the first mounting member to provide the lock. The lock may be provided by snap fitting engagement between the mounting members. Alternatively one mounting member is an interference fit with the other mounting member to provide the lock.

[0045] In one case the sleeve which extends between the mounting members is a proximal portion of the retracting sleeve.

[0046] In another case the sleeve which extends between the mounting members is a connecting sleeve which is separate from the retracting sleeve.

[0047] The first mounting member may comprise a ring member.

[0048] The second mounting member may comprise a ring member.

[0049] In one embodiment the wound protector and retractor device further includes a valve.

[0050] The valve may be attached to the retractor device.

[0051] In one case the valve is attached to the proximal portion of the sleeve.

[0052] In another case a connector is provided between the device and the valve. The connector may comprise a connector sleeve. The connector sleeve may be of substantially fixed length.

[0053] In one embodiment a flexible joint is provided between the valve and the device.

[0054] In another embodiment a malleable joint is provided between the valve and the device. In this case the valve may be offset with respect to the longitudinal axis of the wound retractor.

[0055] In one embodiment the malleable joint is provided by a malleable connecting sleeve section. The malleable connecting sleeve section may be of corrugated configuration.

[0056] In one embodiment the valve is a lip seal.

[0057] Alternatively the valve is an iris seal.

[0058] The valve may be a forearm seal or an instrument seal.

[0059] In one embodiment the device comprises a release arrangement for releasing the device from a retracting configuration. The release arrangement may comprise a pulling device. The pulling device may be coupled to the distal member. The pulling device may comprise a pull cord or a ribbon.

[0060] In another aspect the invention provides a wound protector and retractor device comprising:

[0061] a longitudinal axis;

[0062] a distal member;

[0063] a proximal member; and

[0064] a sleeve extending at least between the distal member and the proximal member,

[0065] the sleeve, on retraction of an incision, defining an excess sleeve portion extending proximally from the proximal member.

[0066] In one embodiment the excess sleeve portion is configured to form a seal such as a forearm seal or an instrument seal. The seal may comprise an iris valve.

[0067] In a further aspect the invention provides a wound protector and retractor device comprising:

[0068] a longitudinal axis;

[0069] a distal member;

[0070] a proximal member; and

[0071] a sleeve extending at least between the distal member and the proximal member,

[0072] the device further comprising a first proximal mounting member and a second proximal mounting member between which at least portion of a sleeve extends.

[0073] The first and second mounting members may be movable relative to one another. The mounting members may be movable axially relative to one another and/or the mounting members are rotationally movable relative to one another. In one case the mounting members are movable relative to one another to configure at least portion of the proximal portion of the sleeve to form a seal. The mounting members may be movable to twist the sleeve to form an iris. The device may comprise a biasing member for biasing the seal into a desired configuration such as a closed configuration.

[0074] In another aspect the invention provides a surgical device comprising a wound retractor, a valve and a connector between the wound protector and the valve, the wound retractor comprising:

[0075] a longitudinal axis;

[0076] a distal member;

[0077] a proximal member; and

[0078] a sleeve extending at least between the distal member and the proximal member.

[0079] The connector may comprise a connector sleeve which may be of substantially fixed length. The connector may comprise a flexible joint between the valve and the retractor. Alternatively the connector comprises a malleable joint between the valve and the retractor. The valve may be

offset with respect to the longitudinal axis of the wound retractor. The malleable joint is provided by a malleable connecting sleeve section. The malleable connecting sleeve sections may be of corrugated configuration.

[0080] In another aspect the invention provides a method for retracting an incision comprising the steps of:

[0081] making an incision in a patient;

[0082] providing a wound retractor comprising a longitudinal axis, a distal member, a proximal member, and a sleeve extending at least between the distal member and the proximal member, the sleeve having a proximal gripping portion;

[0083] inserting the distal member through the incision such that the sleeve extends through the incision and the proximal member is located outside of the incision;

[0084] gripping the gripping portion of the sleeve and pulling the sleeve upwardly to shorten an axial extent of the sleeve located between the distal member and the proximal member.

[0085] In one embodiment, on release of the gripping portion the shortened axial extent of the sleeve between the distal member and the proximal member is substantially maintained.

[0086] The sleeve may be fixed to the proximal member at a first end portion and extending over the proximal member at a second end portion, and the method comprises moving the sleeve over the proximal member as the sleeve is pulled upwardly to shorten the axial extent of the sleeve located between the distal member and the proximal member. The method may comprise the step of moving the sleeve relative to the proximal member including sliding a portion of the sleeve against a radially outer portion of the proximal member.

[0087] In one embodiment a portion of the sleeve located between the distal member and the proximal member includes two material layers. The sleeve may be wrapped around the distal member to form the two material layers.

[0088] The method may comprise sealing the wound retractor, for example by attaching a seal to the wound retractor, by releaseably mounting a seal to the wound retractor. A seal may be mounted a proximal end of the wound retractor. A seal may be mounted to a proximal end of the sleeve.

[0089] In one case the retractor comprises a mounting member and the seal is attached to the mounting member.

[0090] In one embodiment the seal is attached to the proximal end of the wound retractor using a connector.

[0091] The connector may be a connecting sleeve. The connector may be at least partially of a flexible material. Alternatively the connector is at least partially of a malleable material and the method may comprise the step of manipulating the connector into a desired configuration. In one case the desired configuration is a configuration in which the seal is offset from the longitudinal axis of the wound retractor.

[0092] In one embodiment the method comprises pulling the sleeve upwardly to provide an excess sleeve portion extending proximally of the wound retractor. In one case the method comprises the step of cutting away the excess sleeve portion. In another case the method comprises the step of inserting the excess sleeve portion through the retractor. The excess sleeve material may be inserted through the retractor providing an organ retainer.

[0093] In another case the method comprises the step of manipulating the excess sleeve portion to provide a seal.

[0094] In one embodiment the retractor comprises a proximal mounting member and the excess sleeve portion is attached to the mounting member.

[0095] In another embodiment the excess sleeve portion forms, with the mounting member, a chamber. The chamber may have an inflation port and the method comprises inflating the chamber to provide a seal.

[0096] The seal may be a lip seal or an iris seal.

[0097] In one embodiment the wound retractor is sealed with a forearm seal.

[0098] In another embodiment the wound retractor is sealed with an instrument seal.

[0099] In one case the incision is of a size to receive an instrument, when retracted.

[0100] In another case the incision is of a size to receive a forearm, when retracted.

[0101] In a further case the incision is of a size to provide a site for open surgery, when retracted.

[0102] According to the invention there is provided a medical device comprising:

[0103] a retractor member comprising a distal portion for insertion through an incision made in a patient, and a proximal portion for extending from the incision and outside of the patient;

[0104] a distal member associated with the distal portion of the retractor member;

[0105] a proximal member associated with the proximal portion of the retractor member;

[0106] the retractor member being axially movable relative to the distal member to draw the proximal and distal members towards one another thereby shortening the axial extent of the retractor member between the proximal and distal members.

[0107] In one embodiment the retractor member comprises a sleeve member. The sleeve member preferably extends around the distal member.

[0108] In one embodiment the distal member is a ring member such as a resilient ring member, for example, an O-ring.

[0109] In one embodiment the proximal member is connected to the retractor member. The proximal member may be a ring member.

[0110] In one embodiment the sleeve member is of a pliable material.

[0111] In one arrangement the sleeve extends from the proximal member, around the distal member and has a return section outside of the proximal member.

[0112] The return section may have a handle member such as a ring member.

[0113] In one embodiment the device comprises a guide member.

[0114] The retractor member may extend between the guide member and the proximal member.

[0115] The guide member may comprise a receiver for the proximal member.

[0116] The guide member may comprise a guide ring-receiving member.

[0117] The sleeve return section may be configured to provide an integral valve member. In this case the sleeve return section may be twisted to provide an iris valve.

[0118] In another embodiment the sleeve return section is mounted to the guide member.

[0119] The sleeve return section may be extended into the opening defined by the sleeve member.

[0120] The device may comprise a lock for locking the guide member to the proximal member. Typically the guide member is engagable with the proximal member to provide the lock.

[0121] The guide member may be an interference fit with the proximal member.

[0122] In one embodiment of the invention the device includes a valve, such as an iris-type valve.

[0123] In one embodiment the device comprises a biasing member for biasing the valve into a desired position such as the closed position.

[0124] In one arrangement the device comprises a guide member located proximally of the proximal member and a biasing means is provided between the proximal member and the guide member. The biasing means may comprise a spring such as a coil spring.

[0125] In one embodiment a sleeve member extends between the proximal member and the guide member and the biasing means is located around the sleeve. The sleeve member may be an extension of the retractor member.

[0126] In one embodiment the device comprises a release member for releasing the device from an incision. The release member may comprise an elongate member such as a pull ribbon or string extending from a distal end of the device.

[0127] The release member may extend from the distal member.

[0128] In one embodiment the valve is located or locatable proximal of the proximal member. A pliable material may be provided between the valve and the proximal member. The pliable material may comprise a proximal extension of the retractor member.

[0129] In one embodiment the pliable material comprises a sleeve section.

[0130] In another embodiment the valve is a lip seal.

[0131] The invention also provides a method for retracting an incision comprising the steps of:

[0132] providing a device comprising a retractor member having a distal portion and a proximal portion, a distal member associated with the distal portion and a proximal portion associated with the proximal portion;

[0133] inserting the distal member and the distal portion of the retractor member through an incision made in a patient; and

[0134] pulling the retractor member axially relative to the distal member to draw the proximal and distal members towards one another thereby shortening the axial extent of the retractor member between the proximal and distal members and retracting the incision.

#### BRIEF DESCRIPTION OF THE DRAWINGS

[0135] The invention will be more clearly understood from the following description of some embodiments thereof, given by way of example only, with reference to the accompanying drawings, in which:

[0136] FIG. 1 is a perspective view of a retractor according to the invention;

[0137] FIG. 2 is a cross sectional view of the device of FIG. 1;

[0138] FIGS. 3 and 4 are perspective views illustrating the formation of the device of FIGS. 1 and 2;

[0139] FIGS. 5 and 6 are cross sectional views of FIGS. 3 and 4 respectively;

[0140] FIGS. 7 and 8 are perspective views illustrating the use of the device;

[0141] FIGS. 9 and 10 are cross sectional views illustrating the method of use of the device;

[0142] FIG. 11 is a cross sectional view of another device according to the invention in a configuration ready for use;

[0143] FIG. 12 is a perspective view of the device of FIG. 11 with a distal portion inserted through an incision;

[0144] FIG. 13 is a cross sectional view of the device of FIG. 11 with a distal portion inserted through an incision;

[0145] FIG. 14 is a cross sectional view of the device of FIG. 11 in use with an incision retracted;

[0146] FIG. 15 is a perspective view of the device in the configuration of FIG. 14;

[0147] FIG. 16 is a perspective view of the device in situ with an excess sleeve portion being removed;

[0148] FIG. 17 is a cross sectional view of the device in situ with an excess sleeve portion extending back into the incision;

[0149] FIG. 18 is a perspective view of the device in situ with an excess sleeve portion being twisted;

[0150] FIG. 19 is a perspective view similar to FIG. 18 with the excess sleeve portion further twisted to provide an iris valve;

[0151] FIG. 20 is a cross sectional view of another device according to the invention in situ;

[0152] FIG. 21 is a cross sectional view of the device of FIG. 20 with an excess sleeve portion mounted to a guide member;

[0153] FIG. 22 is a cross sectional view of the device of FIG. 21 with the excess sleeve portion inflated to provide an integral everting access part;

[0154] FIG. 23 is a perspective view of another retractor according to the invention incorporating a release device;

[0155] FIG. 24 is a cross sectional view of the retractor of FIG. 23;

[0156] FIG. 25 is a perspective view illustrating the formation of the device of FIG. 23;

[0157] FIG. 26 is a cross sectional view of the device in the configuration of FIG. 25;

[0158] FIG. 27 is a cross sectional view of the retractor of FIGS. 23 to 26, in use;

[0159] FIG. 28 is a cross sectional view of the retractor of FIGS. 23 to 27 illustrating the operation of a release device;

[0160] FIG. 29 is a perspective view of another device according to the invention in an insertion configuration;

[0161] FIG. 30 is a perspective view of the device of FIG. 29 in position in an incision;

[0162] FIG. 31 is another perspective view of the device of FIG. 30 in another configuration;

[0163] FIG. 32 is another view of the device of FIG. 31 with an outer portion severed and a valve being formed;

[0164] FIG. 33 is a view of the device of FIG. 32 with the valve closed;

[0165] FIG. 34 is a perspective view of another device similar to the device of FIGS. 29 to 33 with a valve closed;

[0166] FIG. 35 is a cross sectional view of the device of FIG. 34;

[0167] FIG. 36 is a perspective view of another device similar to the device of FIGS. 29 to 33 incorporating a biasing means in an inserted configuration;

[0168] FIG. 37 is another perspective view of the device of FIG. 36 in a retracting configuration;

[0169] FIG. 38 is a perspective view of the device of FIG. 37 in another configuration and excess sleeve being removed;

[0170] FIG. 39 is a perspective view of the device of FIG. 38 with a valve closed;

[0171] FIG. 40 is a perspective view of the device of FIG. 39 with a valve partially open;

[0172] FIGS. 41A and 41B are perspective views of the device of FIG. 39;

[0173] FIGS. 41C and 41D are perspective views of the device of FIG. 39 with an object inserted through the valve;

[0174] FIG. 42 is a perspective view of another device according to the invention;

[0175] FIG. 43 is a cross sectional view of the device of FIG. 42 in position in an incision;

[0176] FIG. 44 is a cross sectional view of the device of FIG. 43 with an object extending therethrough;

[0177] FIG. 45 is a cross sectional view similar to FIG. 44 with an object offset from a longitudinal axis of the device;

[0178] FIG. 46 is a cross sectional view of another device according to the invention on insertion into an incision;

[0179] FIG. 47 is a cross sectional view of the device of FIG. 46 with an incision retracted;

[0180] FIGS. 48 and 49 are cross sectional views of the device of FIG. 47 showing the formation of an iris valve;

[0181] FIG. 50 is a cross sectional view of another access port;

[0182] FIG. 51 is a cross sectional view of the port of FIG. 50 with an instrument in position;

[0183] FIGS. 52 to 55 are cross sectional views of another access port;

[0184] FIGS. 56 and 57 are cross sectional views of a further access port;

[0185] FIGS. 58 and 59 are cross sectional views of another access port;

[0186] FIGS. 60 to 62 are cross sectional views of a further access port;

[0187] FIGS. 63 to 66 are cross sectional views of another access port;

[0188] FIGS. 60 to 72 are cross sectional views of another access port of the invention.

#### DETAILED DESCRIPTION

[0189] Referring to the drawings, and initially to FIGS. 1 to 10 thereof there is illustrated a device 1 comprising a retractor member provided by a sleeve 2, a distal member provided by a distal ring 3 of resilient material such as an O-ring and a proximal member provided by a proximal ring 4 which may also be an O-ring.

[0190] The sleeve 2 is of any suitable material such as of pliable plastics film material and comprises a distal portion 5 for insertion through an incision 6, in this case made in a patient's abdomen 7, and a proximal portion 8 for extending from the incision 6 and outside of the patient.

[0191] In this case the distal ring 3 is not fixed to the sleeve 2 but rather the sleeve is led around the ring 3 and is free to move axially relative to the distal ring 3 somewhat in the manner of a pulley. The proximal ring 4 is fixed to the sleeve 2, in this case at the proximal inner end thereof. The sleeve 2 terminates in a handle or gripping portion which in this case is reinforced by a gripping ring 15.

[0192] To configure the retractor device according to the invention a sleeve 2 is first provided with the gripping ring 15 fixed at one end and the proximal ring 4 fixed at the other end. The distal ring 3 is then placed over the sleeve 2 as illustrated in FIGS. 4 and 6. The gripping ring 15 is then used to manipulate the sleeve 2 so that the sleeve 2 is folded back on itself into

the configuration of FIGS. 1 and 2 in which the gripping ring 15 is uppermost. The sleeve extends from the proximal ring 4 and the distal ring 3 is contained between inner and outer layers 2a, 2b of the sleeve 2. The device is now ready for use.

[0193] The resilient distal ring 3 is scrunched up and inserted through the incision 6 with the distal end 5 of the sleeve 2 as illustrated in FIG. 4. The sleeve 2 is then pulled upwardly in the direction of the arrows A in FIGS. 8 to 10. On pulling of the sleeve 2 upwardly the outer layer 2b is pulled up while the inner layer 2a is drawn around the proximal ring 3. This results in shortening the axial extent between the proximal ring 4 and the distal ring 3, tensioning the sleeve and applying a retraction force to the margins of the incision 6. The system appears to be self locking because when tension is applied to the sleeve 2 and the pulling force is released the rings 3, 4 remain in position with a retraction force applied. Frictional engagement between the layers of the sleeve in this configuration may contribute to this self locking.

[0194] As the incision is being retracted the margins are also protected by the sleeve. On retraction, an access port is provided, for example for a surgeon to insert his hand and/or an instrument to perform a procedure. The device may be used as a retractor in open surgery or as a base for a valve/seal to allow it to be used in hand assisted laparoscopic surgery or for instrument or hand access generally.

[0195] Excess sleeve portion 20 outside the incision may, for example, be cut-away.

[0196] The retractor is suitable for a range of incision sizes and is easily manufactured. It is also relatively easy to manipulate, in use. It not only retracts but also protects the incision.

[0197] Referring now to FIGS. 11 to 19 there is illustrated another device 50 according to the invention which is similar to the device described above with reference to FIGS. 1 to 10 and like parts are assigned the same reference numerals. In this case the device comprises a guide member 51 for the proximal ring 4. The guide member 51 is in the form of an annular ring member with an inwardly facing C-shaped groove 52 which is sized to accommodate the ring 4 as illustrated. The outer layer of the sleeve 2 is interposed between the ring 4 and the guide 51 to further control the pulling of the sleeve and thereby further controlling the application of the retraction force. The guide 51 also assists in stabilising the proximal ring 4. The use of the device 50 is illustrated in FIGS. 12 to 15 is similar to that described above.

[0198] Any suitable guide such as the ring 51 may be used to assist in retaining/stabilising the proximal ring 4 in a desired position during pulling up of the sleeve to retract the incision. The guide may be located proximal of the ring 4.

[0199] The guide member provides a monitoring member to which devices such as valves may be attached.

[0200] Referring to FIG. 16, it will be noted that in one case the excess sleeve portion 20 may be cut-away.

[0201] Referring to FIG. 17, in this case the excess sleeve portion is inverted 60 into the incision. In this configuration it may act as an organ retractor, or provide the surgeon with an open tunnel to work in.

[0202] Referring to FIGS. 18 and 19 in this case the excess sleeve portion is twisted to form an iris diaphragm valve 65.

[0203] In the embodiment illustrated in FIGS. 20 to 22 a device 70 according to the invention has an integral seal/valve 71. The device 70 is similar to that described above with reference to FIGS. 11 to 19 and like parts are assigned the same reference numerals. In this case the guide member 50

has an outer groove **75** to receive the gripping ring **15** as illustrated in FIGS. **21**. The excess sleeve portion **20** is folded out and down and the gripping ring **15** is engaged in the groove **75** to provide an air tight seal. In this configuration the excess sleeve may be inflated through an inflation port **76** to provide an integral access valve **71**. The valve may be used to sealingly engage a hand, instrument or the like passing there-through. The inflated sleeve portion defining the valve is evertable on passing an object therethrough.

[0204] Referring to FIGS. **23** to **28** there is illustrated another retractor **80** according to the invention which is similar to the retractors described above and like parts are assigned the same reference numerals. In this case the retractor **80** has a release mechanism which in this case is provided by a release cord or ribbon **81** which is coupled at one end **82** to the inner ring **3** and terminates in an outer free end **83** which may be grasped by a user. The ribbon **81**, on assembly, is led through the gap between the proximal ring **4** and the outer guide member **51** so that it is positioned between the ring **4** and the guide member. The ribbon **81** facilitates release of the self locked sleeve in the in-use configuration sited in an incision. Pulling on the ribbon **81** pulls on the inner ring **3**, allowing the ring **3** to be released from the inner wall of the incision to thereby release the device. The flexibility of the ring **3** facilitates this movement.

[0205] The advantage of this arrangement is that a user can readily release the device from its self locked retracting configuration.

[0206] Referring to FIGS. **29** to **33** there is illustrated another device **90** according to the invention in which parts similar to those of the devices described above are assigned the same reference numerals. In this case the device **90** has a lower guide ring **51** for the proximal ring **4** and an outer guide assembly provided by an upper guide ring **91** and a second proximal ring **92** between which the sleeve **2** is led. In all relevant embodiments the upper guide such as the ring **91** may provide a second mounting member located proximally of the first guide member such as the ring **51** which also provides a mounting member. The device is used to first retract an incision as described above. During this phase the outer guide assembly is conveniently external of the guide member **51** and proximal ring **4**. Indeed, it may be completely detached from the sleeve **2** and subsequently coupled to the sleeve **2** at an appropriate stage such as when the incision is retracted as illustrated in FIG. **30**. The outer guide assembly is then moved downwardly towards the incision as illustrated in FIG. **31**. This may be achieved while pulling the sleeve **2** upwardly. When the guide assembly is adjacent to the guide member **51** excess sleeve length may be severed as illustrated in FIG. **32**. By twisting the guide assembly relative to the guide member **51** the sleeve **2** is twisted, closing down the lumen of the sleeve **2** and forming an iris type access valve **95** as illustrated in FIG. **33**. In this way a sealed access port is provided for hand and/or instrument access through the incision.

[0207] It will be appreciated that while reference has been made to an incision made by a surgeon the devices of the invention may be applied for retraction of any opening such as a body opening.

[0208] Referring to FIGS. **34** and **35** there is illustrated another retractor device **100** according to the invention which is similar to the device of FIGS. **29** to **33** and like parts are assigned the same reference numerals. In this case a releasable lock is provided to maintain the access valve **95** closed. For interlocking, in this instance the upper guide ring **91** is an

interference fit with the lower guide ring **51**. Various other locking arrangements may be used such as a screw threaded or bayonet type engagement, magnets, clips and the like.

[0209] Referring to FIGS. **36** to **41D** there is illustrated another retractor device **110** according to the invention which is similar to the device of FIGS. **29** to **33** and like parts are assigned the same reference numerals. In this case the device incorporates a biasing means to bias an integral valve into a closed position. The biasing means is in this case provided by a coil spring **111** which is located around the sleeve between the guide rings **51**, **91**. In use, the device is used in a similar manner to the device of FIGS. **29** to **33** except that on movement of the upper guide ring **91** downwardly the spring **111** also moves downwardly towards the lower guide ring **51**, initially into the position illustrated in FIG. **38**. Excess sleeve material may be removed at this stage. The spring **111** is tensioned as the upper ring **91** is rotated while pushing the upper ring **91** downwardly. The sleeve material between the two rings **51**, **91** is twisted, forming an iris type valve **112** as illustrated in FIG. **39**. To open the valve **112** to pass an object such as an instrument, hand, arm or the like therethrough a downward force may be applied to push the upper ring **91** towards the lower ring **51** against the biasing of the spring. This configuration is illustrated in FIG. **40**. When the object is inserted the upper ring member **91** is released, allowing the valve to close around the object. The operation of the device **110** will be readily apparent from FIGS. **41A** to **41D**. In FIG. **41A** the valve **112** is illustrated in a closed resting configuration. FIG. **41B** shows the application of a downward force to open the valve **112**. An object such as an instrument **113** is shown inserted through the open valve **112** in FIG. **41C**. In FIG. **41D** the downward pressure on the upper ring **91** is released allowing the valve **112** to close around the object **113**.

[0210] Referring now to FIGS. **42** to **45** there is illustrated another device **120** according to the invention which has some aspects similar to the device of FIGS. **11** to **18** and like parts are assigned the same reference numerals. In this case the device has a lip seal **121**. The lip seal **121** is provided by a membrane with a central aperture **122** through which an object **123** such as an instrument is passed. The lip seal **121** is located on the sleeve **2** proximally of the guide ring **51** such that a proximal flexible sleeve section **125** is provided. This sleeve section **125** is very useful in facilitating offset movements of the object **123** as illustrated in FIG. **45**. The sleeve section **125** accommodates movement of the object **123** whilst maintaining sealing engagement between the lip seal **121** and the object **123**. It will be appreciated that this feature, as with several other features described above may be utilised in association with other constructions of wound protector/retractors and access parts generally other than those illustrated in the drawings.

[0211] Referring to FIGS. **46** to **48** there is illustrated another device **130** according to the invention which has some features similar to those of FIGS. **11** to **15**, like parts being assigned the same reference numerals. In this case the sleeve has a proximal section external of the wound when the device is in the retracting configuration. This proximal sleeve section comprises a first portion **131** extending from the guide ring **51** and a second portion **132** extending from the first portion **131**. The second portion **132** is defined between two spaced-apart iris rings **134**, **135**. It will be noted that the iris rings **134**, **135** have engagement features such as projections and grooves for interengagement on assembly. The iris ring **134** also has an

engagement element, in this case provided by a groove 137 for engagement on assembly with a corresponding engagement element of the guide ring 51 which in this case is provided by a projection 138.

[0212] The device is fitted as described above to retract an incision, leaving the first and second sleeve portions 131, 132 extending proximally. The first sleeve portion 131 is redundant and can be removed or scrunched up on assembly of the first iris ring 134 to the guide ring 138 as illustrated in FIG. 48. The second or upper iris ring 135 is then rotated to twist the sleeve section 132 to form an iris-type seal as illustrated in FIG. 49. The iris ring 135 is engaged with the iris ring 134 as illustrated to maintain the valve closed.

[0213] In some of the embodiments described above a valve 829 is mounted directly to a retractor base 811. It is possible to provide a flexible coupling between the retractor 811 and the valve 829. For example, as illustrated in FIGS. 93 and 94 such a flexible coupling is provided by a length of flexible sleeve 830 extending between the retractor 811 and the valve 829. The flexible sleeve 830 may be formed by excess retractor sleeve material attached to the valve 829.

[0214] In a further embodiment of the invention as illustrated in FIGS. 52 to 57 a valve 860 may be coupled to the retractor 811 in such a way as to facilitate a flexible joint therebetween. For example, a fixed length sleeve 862 may extend between an outer proximal ring 863 of the retractor 811 and the valve 860. Excess sleeve material 864 from the retractor 811 may pass up through the valve 860. The valve 860 may be pushed down and the excess sleeve pulled up to firmly lock the base retractor 811 in the incision. Excess sleeve material 864 may be cut-away and removed, if desired. The flexible sleeve 864 allows the instrument to tilt as illustrated in FIG. 57 without compromising the valve seal to the shaft of the instrument/object 814.

[0215] As illustrated in FIGS. 58 and 59 a spring 867 may be provided between the valve 860 and the retractor proximal ring 863 for more controlled flexibility.

[0216] Referring now to FIGS. 60 to 62 another modular system is illustrated in which a valve 870 is releasably mounted to a retractor 811. The retractor 811 may have a proximal ring 871 with a recess 872 to receive the valve 870. An instrument shaft 814 can readily pass through the valve 870 and retractor 811. At least a section 873 of the shaft 814 can be bent or steered almost immediately distal of the retractor.

[0217] Referring now to FIGS. 63 to 66 any suitable valve 880 may be coupled to a retractor 811 using excess sleeve material 881 from the retractor 811. The valve 880 may be pulled upwardly to deploy the base retractor 811. The excess sleeve material 881 provides a flexible neck which facilitates easy introduction of objects such as an instrument 883, even one having a bent shaft (FIG. 119). As illustrated in FIG. 120 such an arrangement also facilitates additional instrument reach by allowing the valve 880 to be moved closer to the base retractor 811.

[0218] Referring to FIGS. 67 to 72 there is illustrated another access port comprising a wound protector and retractor device 811 and a valve 900. The valve 900 is connected to an outer guide ring 901 of the retractor device 811 by a sleeve 902 which in this case is of malleable material of corrugated configuration somewhat in the manner of the bendable hinge portion of a bendable drinking straw. The sleeve 902 may be pre-shaped to be offset from the longitudinal axis of the retractor to facilitate ease of insertion of an instrument or the

like. The corrugated sleeve 902 may be compressed as illustrated in FIG. 68 to provide a low profile to facilitate outlining any of excess retractor sleeve as illustrated in FIGS. 69 and 70. Thereafter, the corrugated sleeve 902 can be extended/elongated and is readily manipulated into a desired configuration. Because the sleeve 902 is malleable it will retain a desired bent shape, even when the abdomen is pressurised. Any excess retractor sleeve material 905 may be cut-away as illustrated or used as described above.

[0219] In this context the term “malleable” is used to denote an element which is capable of being manipulated into a desired position and/or orientation, and which retains this manipulated position and/or orientation under the typical stresses and strains applied when used for an intended purpose with a patient, for example during partial insertion of a laparoscopic instrument.

[0220] The access ports of the invention can be used in a number of ways. In one method the retractor is used as described above, the distal inner ring being inserted into an incision, the outer ring being slid to controllably radially expand the incision. The retractor may then be locked in position. If necessary, the outer ring can be moved further downwardly to create a larger incision.

[0221] In some arrangements an instrument may be bent manually outside the body and the bent instrument is delivered through the access port to readily access the operative site.

[0222] In a further embodiment an instrument is inserted into the access port and the surgeon uses the abdominal wall itself to bend the instrument and then insert the bent section further into the abdomen.

[0223] In all cases the sleeve may be gripped by gripping a valve or other element mounted thereto.

[0224] The access ports of the invention have at least some of the following advantages:

[0225] Controlled Radial Expansion

[0226] 1. Greater access using smaller incision

[0227] 2. Can vary incision size as need be (e.g. specimen removal during lap coli.)

[0228] Greater Sealing Capabilities

[0229] 1. No gas leakage from the wound margins

[0230] 2. Cannot be inadvertently pulled out of the incision

[0231] 3. Will seal any incision and never require secondary sealing method (suture, Hasson port, etc.)

[0232] Eliminate Intra-Abdominal Profile

[0233] 1. Gives back more working space in the abdomen (critical in pelvic surgery)

[0234] 2. Perineal access for operations such as Radical Prostatectomy.

[0235] Protection of Wound from Infection and Cancer Seeding

[0236] 1. Tight seal with no “chimney stack” effect

[0237] 2. Upon removal all areas of potential contamination are isolated from the incision

[0238] Reduced Extra-Abdominal Profile

[0239] 1. Will increase the effective working length of an instrument

[0240] 2. Greater working area outside the abdomen

[0241] Increase the Freedom of Movement of Conventional Laparoscopic Instruments

[0242] The invention is not limited to the embodiments hereinbefore described, with reference to the accompanying drawings, which may be varied in construction and detail.

1. A wound protector and retractor device comprising:  
 a longitudinal axis;  
 a distal member;  
 a proximal member; and  
 a sleeve extending at least between the distal member and the proximal member,  
 the sleeve having a proximal gripping portion for pulling the sleeve upwardly to shorten an axial extent located between the distal member and the proximal member.
2. A wound protector and retractor device as claimed in claim 1 wherein, on release of the gripping portion the shortened axial extent between the distal member and the proximal member is substantially maintained without a requirement for an additional locking device.
- 3-42. (canceled)
43. A wound protector and retractor device as claimed in claim 1 wherein the device comprises a first proximal mounting member and a second proximal mounting member between which at least portion of a sleeve extends.
44. A wound protector and retractor device as claimed in claim 43 wherein the first and second mounting members are movable relative to one another.
45. A wound protector and retractor device as claimed in claim 44 wherein the mounting members are movable axially relative to one another.
- 46-60. (canceled)
61. A wound protector and retractor device as claimed in claim 1 further including a valve.
62. A wound protector and retractor device as claimed in claim 61 wherein the valve is attached to the device.
63. A wound protector and retractor device as claimed in claim 62 wherein the valve is attached to the proximal portion of the sleeve.
64. A wound protector and retractor device as claimed in claim 62 wherein a connector is provided between the device and the valve.
65. A wound protector and retractor device as claimed in claim 64 wherein the connector comprises a connector sleeve.
66. A wound protector and retractor device as claimed in claim 65 wherein the connector sleeve is of substantially fixed length.
67. A wound protector and retractor device as claimed in claim 62 wherein a flexible joint is provided between the valve and the device.
68. A wound protector and retractor device as claimed in claim 62 wherein a malleable joint is provided between the valve and the device.
69. A wound protector and retractor device as claimed in claim 68 wherein the valve is offset with respect to the longitudinal axis of the wound retractor.
- 70-93. (canceled)
94. A surgical device comprising a wound retractor, a valve and a connector between the wound protector and the valve, the wound retractor comprising:  
 a longitudinal axis;  
 a distal member;  
 a proximal member; and  
 a sleeve extending at least between the distal member and the proximal member.
95. A wound protector and retractor device as claimed in claim 94 wherein the connector comprises a connector sleeve.
96. A wound protector and retractor device as claimed in claim 95 wherein the connector sleeve is of substantially fixed length.
- 97-101. (canceled)
102. A method for retracting an incision comprising the steps of:  
 making an incision in a patient;  
 providing a wound retractor comprising a longitudinal axis, a distal member, a proximal member, and a sleeve extending at least between the distal member and the proximal member, the sleeve having a proximal gripping portion;  
 inserting the distal member through the incision such that the sleeve extends through the incision and the proximal member is located outside of the incision;  
 gripping the gripping portion of the sleeve and pulling the sleeve upwardly to shorten an axial extent of the sleeve located between the distal member and the proximal member.
103. A method as claimed in claim 102 wherein, on release of the gripping portion the shortened axial extent of the sleeve between the distal member and the proximal member is substantially maintained.
- 104-134. (canceled)

\* \* \* \* \*

专利名称(译)	伤口牵开器装置		
公开(公告)号	<a href="#">US20160022257A1</a>	公开(公告)日	2016-01-28
申请号	US14/753796	申请日	2015-06-29
[标]申请(专利权)人(译)	阿特波斯有限公司		
申请(专利权)人(译)	阿特洛波斯有限公司		
当前申请(专利权)人(译)	阿特洛波斯有限公司		
[标]发明人	BONADIO FRANK BUTLER JOHN VAUGH TREVOR MACNALLY SHANE J REID ALAN		
发明人	BONADIO, FRANK BUTLER, JOHN VAUGH, TREVOR MACNALLY, SHANE J. REID, ALAN		
IPC分类号	A61B17/02 A61B17/00 A61B17/34		
CPC分类号	A61B17/0293 A61B17/3498 A61B2017/0212 A61B2017/0225 A61B2017/3443 A61B17/3423 A61B1/32 A61B17/3431 A61B17/3439 A61B17/3462 A61B2017/00557 A61B2017/3482 A61B2017/3484 A61B2017/3492		
优先权	19980997 1998-12-01 IE 19990111 1999-02-15 IE 19990861 1999-10-14 IE 19991053 1999-12-16 IE 2000650010 2000-02-18 EP 60/415780 2002-10-04 US 60/428215 2002-11-22 US 60/490909 2003-07-30 US		
其他公开文献	US9700296		
外部链接	<a href="#">Espacenet</a> <a href="#">USPTO</a>		

摘要(译)

伤口保护器和牵开器装置 1 包括套筒 2，远端构件由弹性材料的远端环 3 提供，并且提供近端构件通过近端环 4。套筒 2 围绕环 3 并且相对于远端环轴向自由移动有点像滑轮的方式。近端环 4 在这种情况下在其近端内端处固定到套筒 2 上。套筒 2 终止于手柄或抓握部分，该手柄或抓握部分由夹紧环 15 加强。套筒从近端环 4 延伸。内层和外层之间包含远端环 3 套筒 2。弹性远端环 3 被压扁并穿过切口 6。然后向上拉套筒 2。在向上拉套筒 2 时，外层 2 拉出，而内层 2 > a 围绕近端环 3 绘制。这导致近端环 4 和远端环 3 之间的轴向范围缩短，张紧套管并向切口边缘施加收缩力。当切口缩回时，边缘也受到套管的保护。在缩回时，提供进入端口，例如用于外科医生插入他的手和/或器械以执行手术。该装置可用作开放手术中的牵开器或用作瓣膜/密封件的基座，以允许其用于手助腹腔镜手术或用于器械进入或手动进入通常。

