



US 20090054909A1

(19) **United States**

(12) **Patent Application Publication**
Farritor et al.

(10) **Pub. No.: US 2009/0054909 A1**

(43) **Pub. Date: Feb. 26, 2009**

(54) **METHODS AND SYSTEMS OF ACTUATION
IN ROBOTIC DEVICES**

on Jul. 12, 2007, provisional application No. 60/949,391, filed on Jul. 12, 2007, provisional application No. 60/990,076, filed on Nov. 26, 2007.

(75) Inventors: **Shane M. Farritor**, Lincoln, NE (US); **Mark Rentschler**, Omaha, NE (US); **Amy Lehman**, Seward, NE (US); **Stephen R. Platt**, Garland, NE (US); **Jeff Hawks**, Lincoln, NE (US)

Publication Classification

(51) **Int. Cl.**
A61B 19/00 (2006.01)
(52) **U.S. Cl.** **606/130**

Correspondence Address:
FAEGRE & BENSON LLP
PATENT DOCKETING
2200 WELLS FARGO CENTER, 90 SOUTH SEVENTH STREET
MINNEAPOLIS, MN 55402-3901 (US)

(57) **ABSTRACT**

The embodiments disclosed herein relate to various medical device components, including components that can be incorporated into robotic and/or in vivo medical devices. Certain embodiments include various actuation system embodiments, including fluid actuation systems, drive train actuation systems, and motorless actuation systems. Additional embodiments include a reversibly lockable tube that can provide access for a medical device to a patient's cavity and further provides a reversible rigidity or stability during operation of the device. Further embodiments include various operational components for medical devices, including medical device arm mechanisms that have both axial and rotational movement while maintaining a relatively compact structure. medical device winch components, medical device biopsy/stapler/clamp mechanisms, and medical device adjustable focus mechanisms.

(73) Assignee: **Board of Regents of the University of Nebraska**, Lincoln, NE (US)

(21) Appl. No.: **12/171,413**

(22) Filed: **Jul. 11, 2008**

Related U.S. Application Data

(60) Provisional application No. 61/025,346, filed on Feb. 1, 2008, provisional application No. 60/949,390, filed

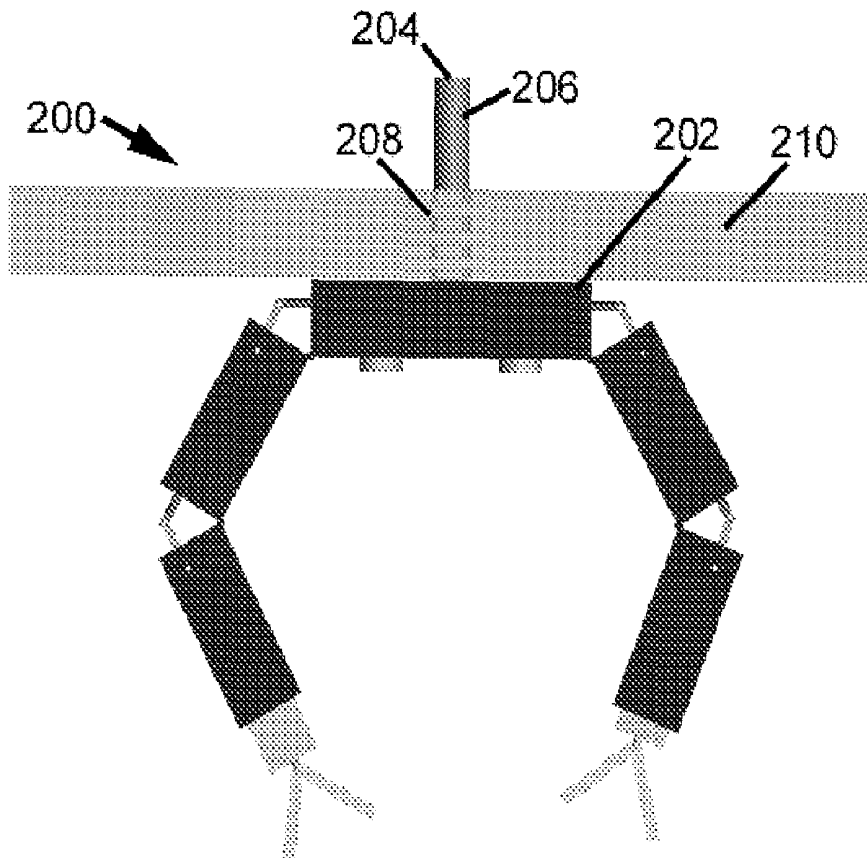

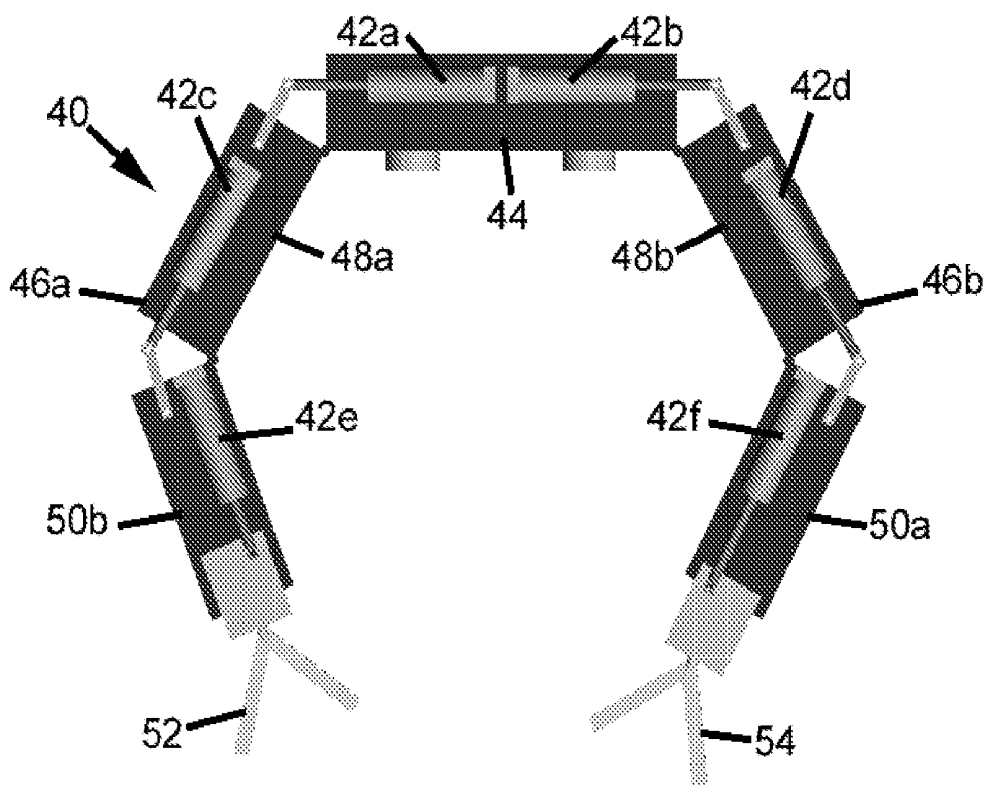

Figure 2A

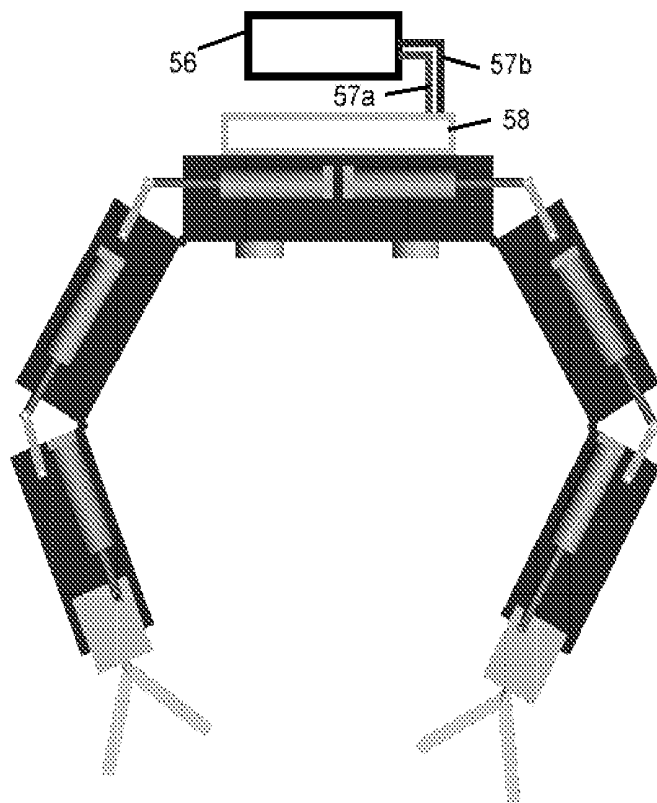

Figure 2B

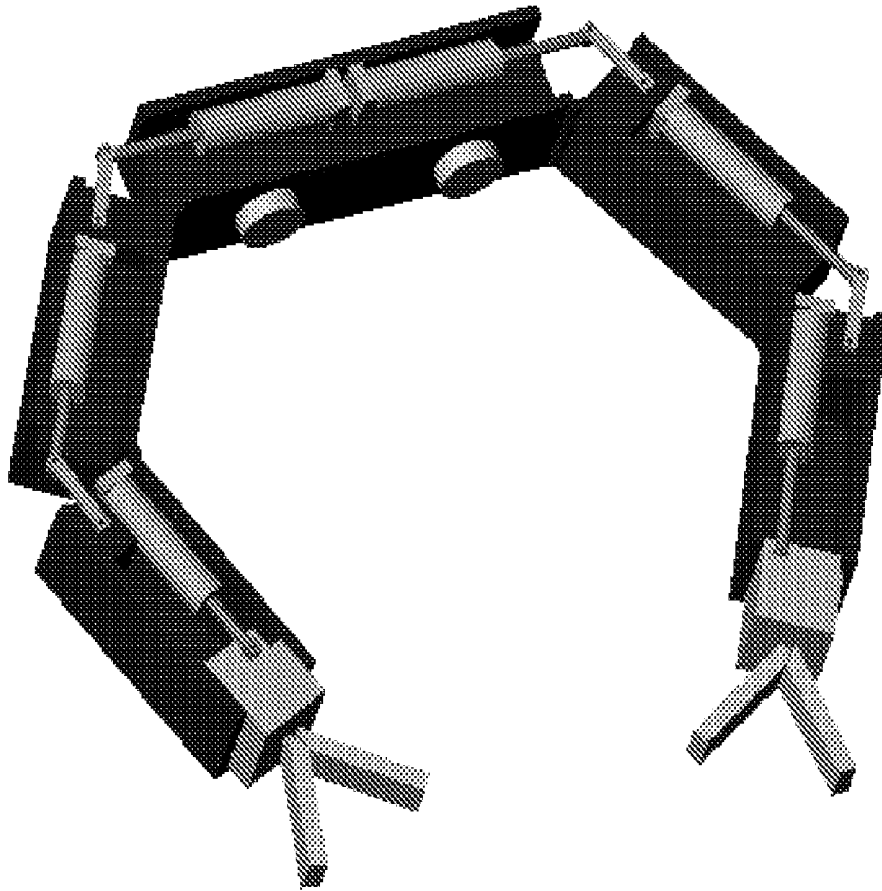

Figure 3

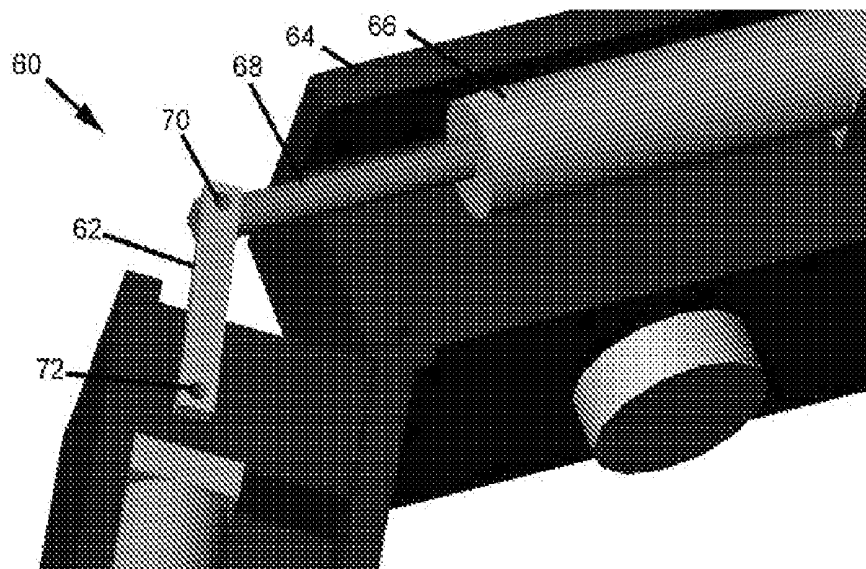

Figure 4

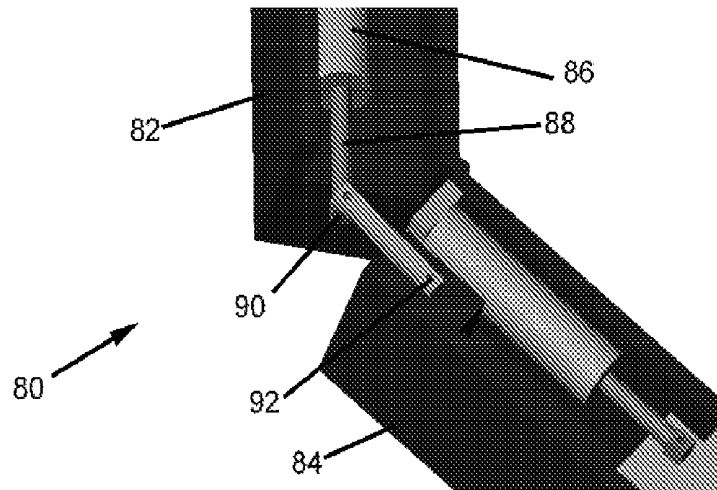

Figure 5

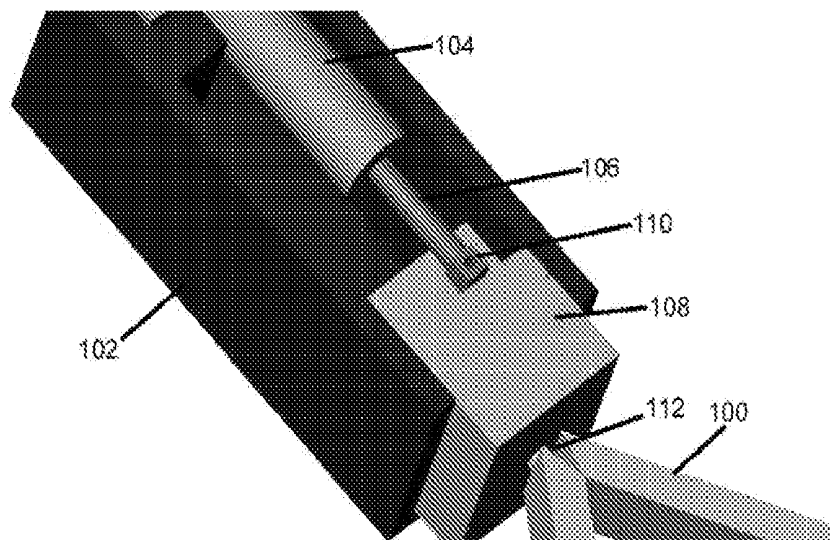

Figure 6

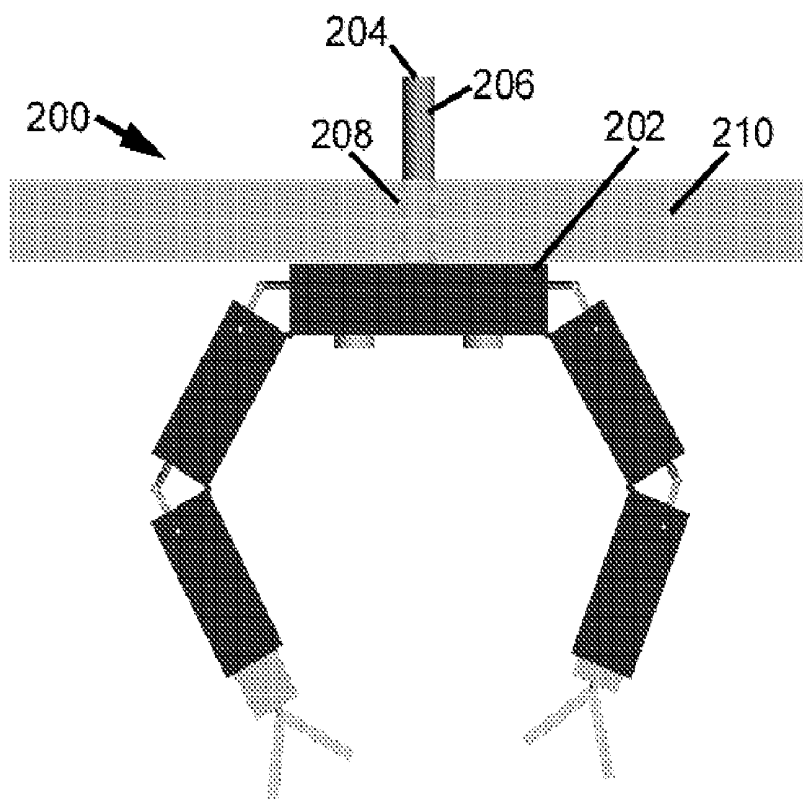

Figure 7A

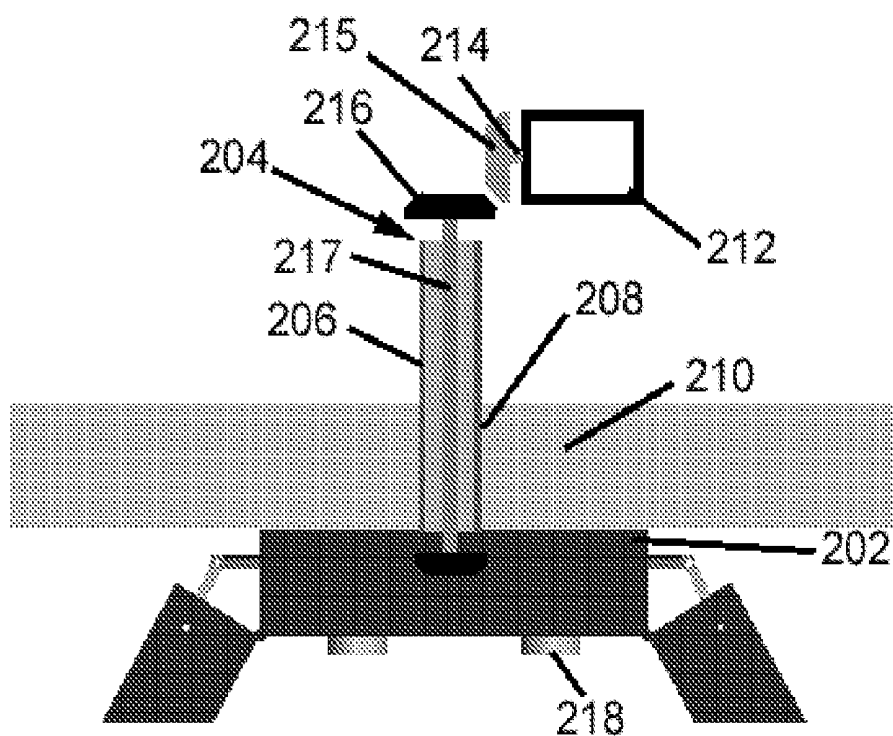

Figure 7B

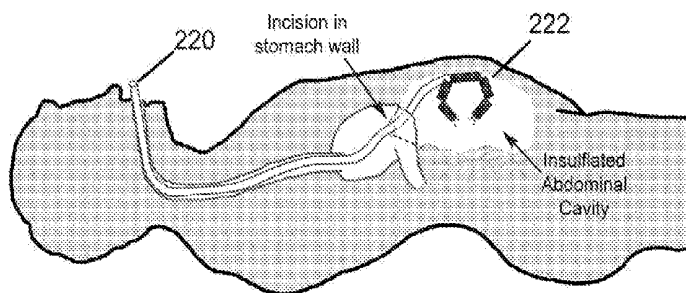

Figure 8

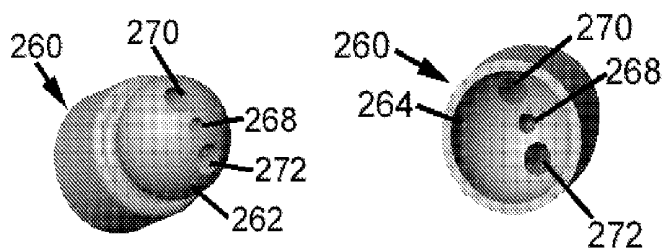

Figure 9A and Figure 9B

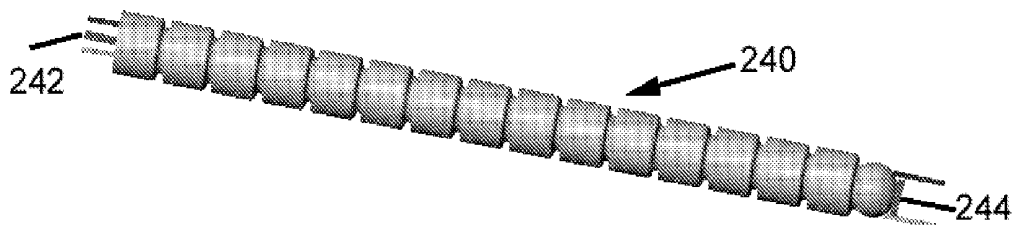

Figure 10

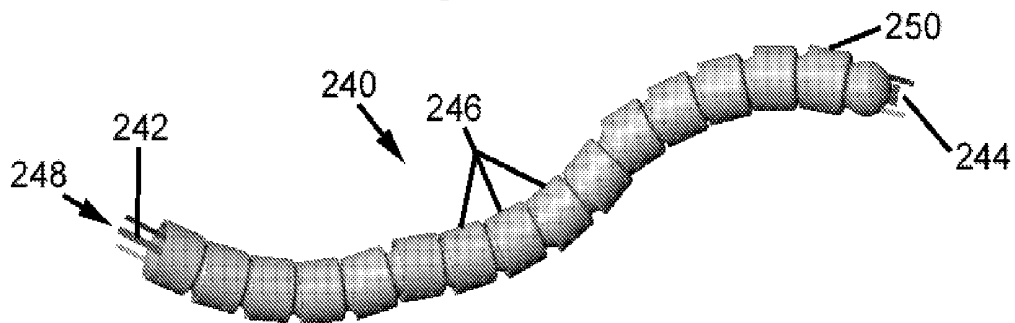

Figure 11

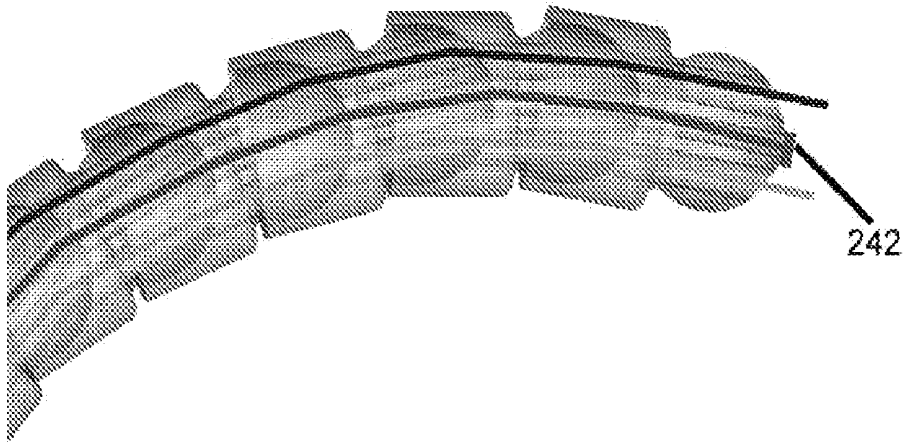

Figure 12

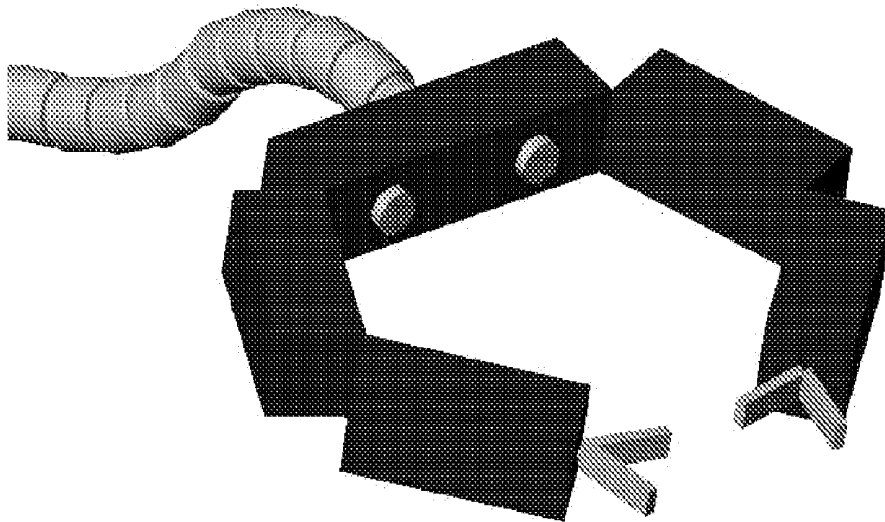

Figure 13

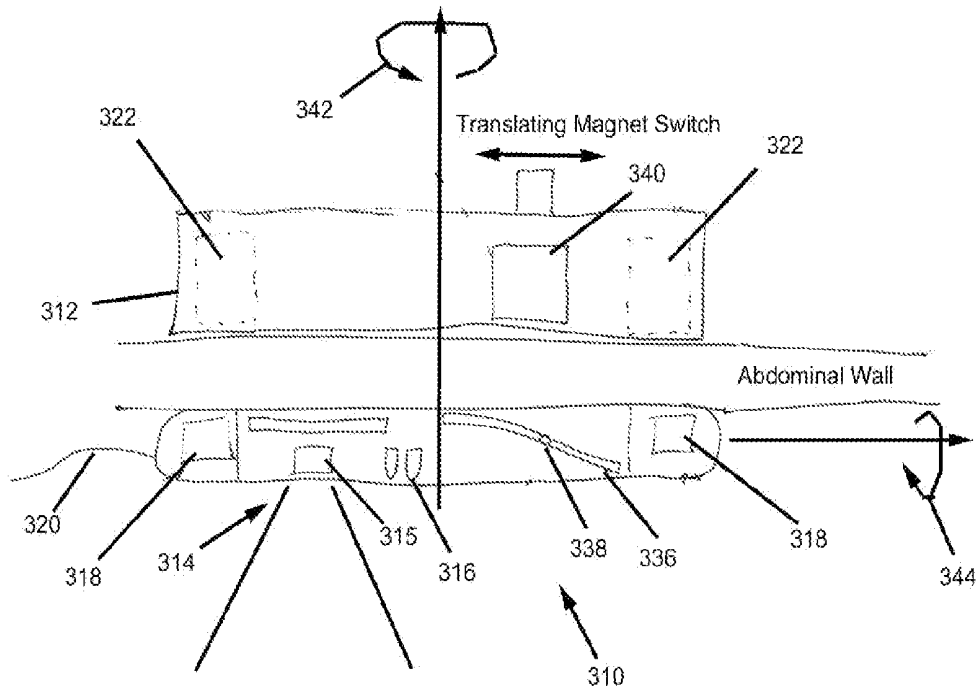

Figure 14A

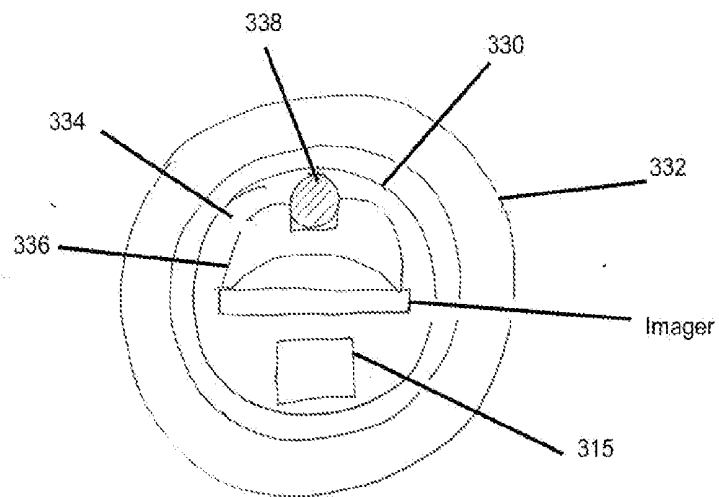

Figure 14B

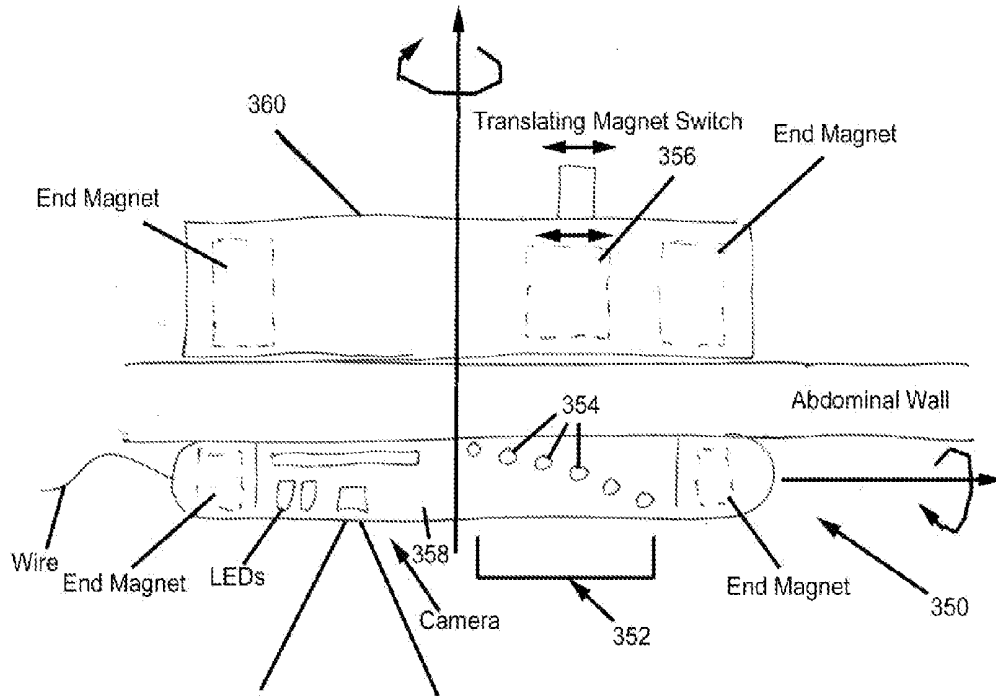

Figure 15

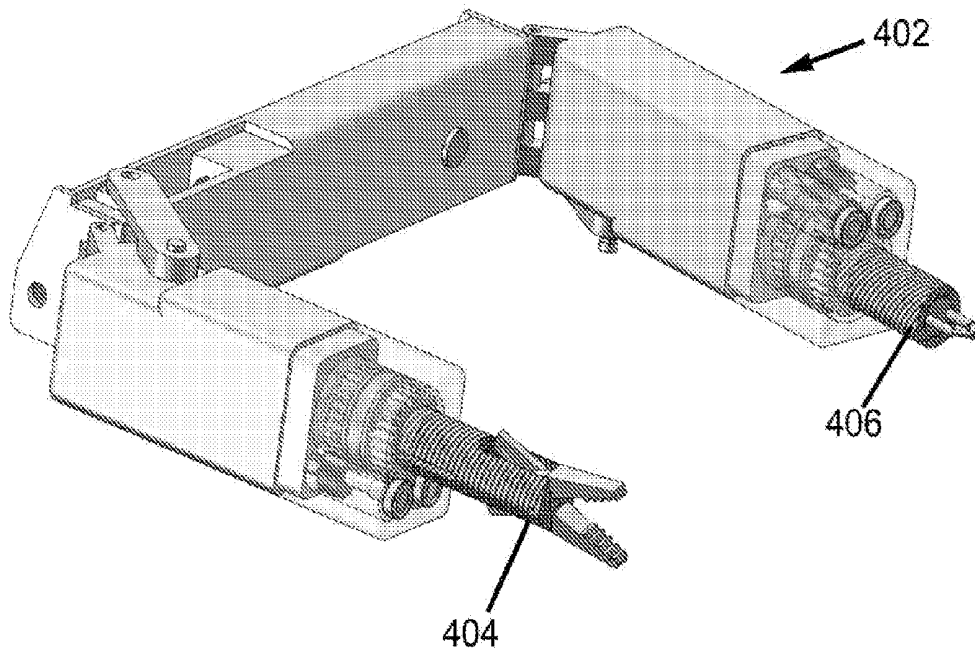

Figure 16

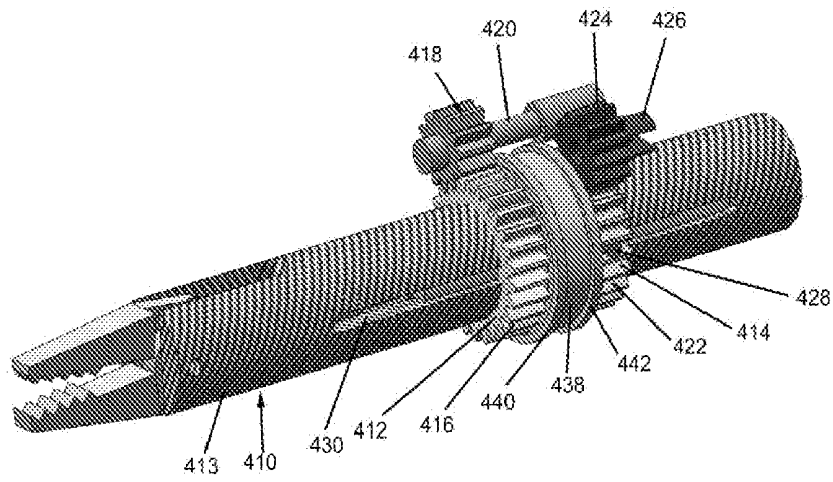

Figure 17A

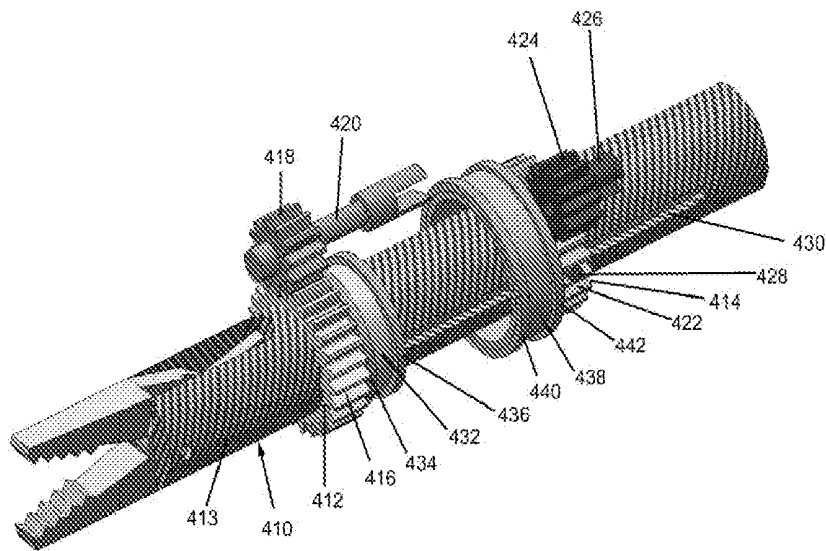

Figure 17B

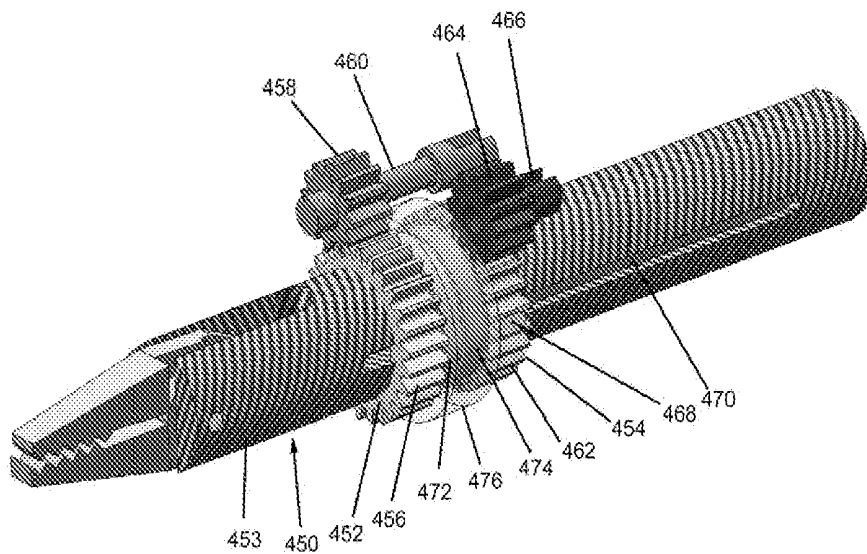

Figure 18

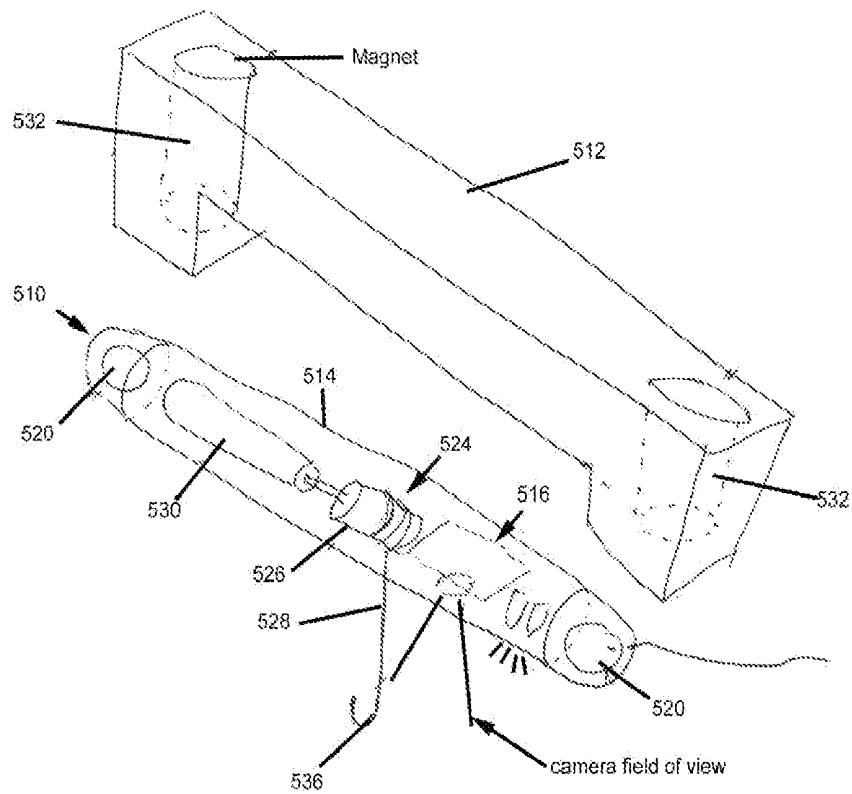

Figure 19A

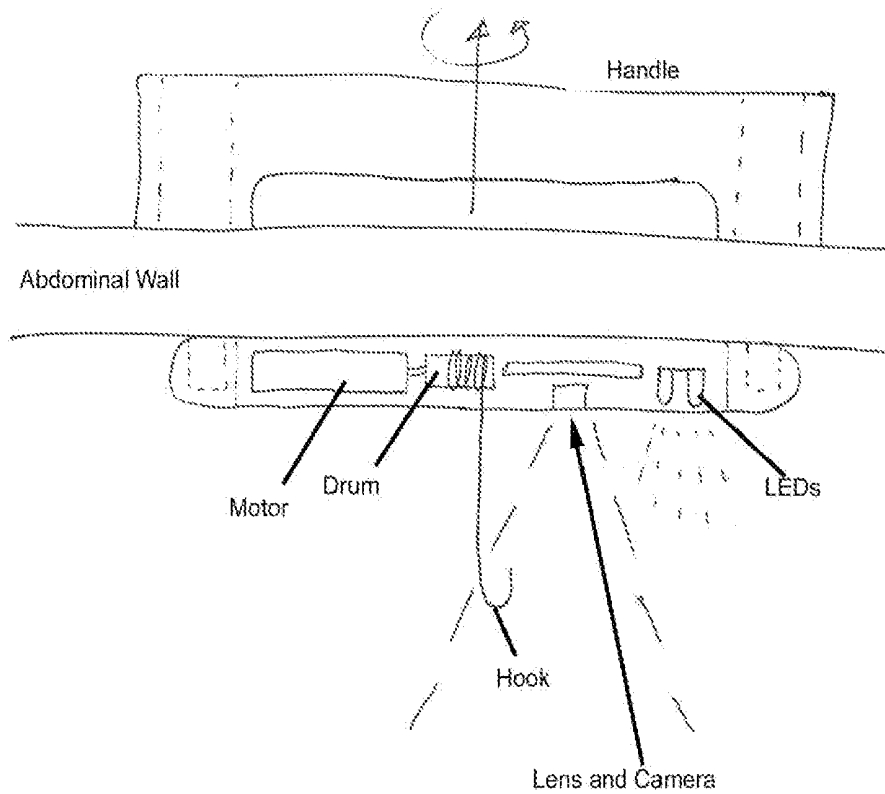

Figure 19B

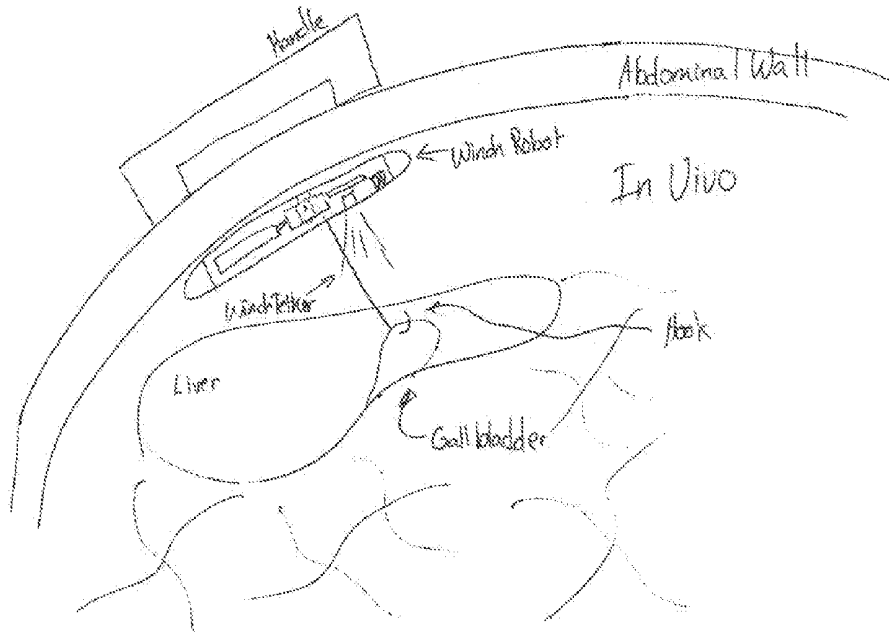

Figure 20

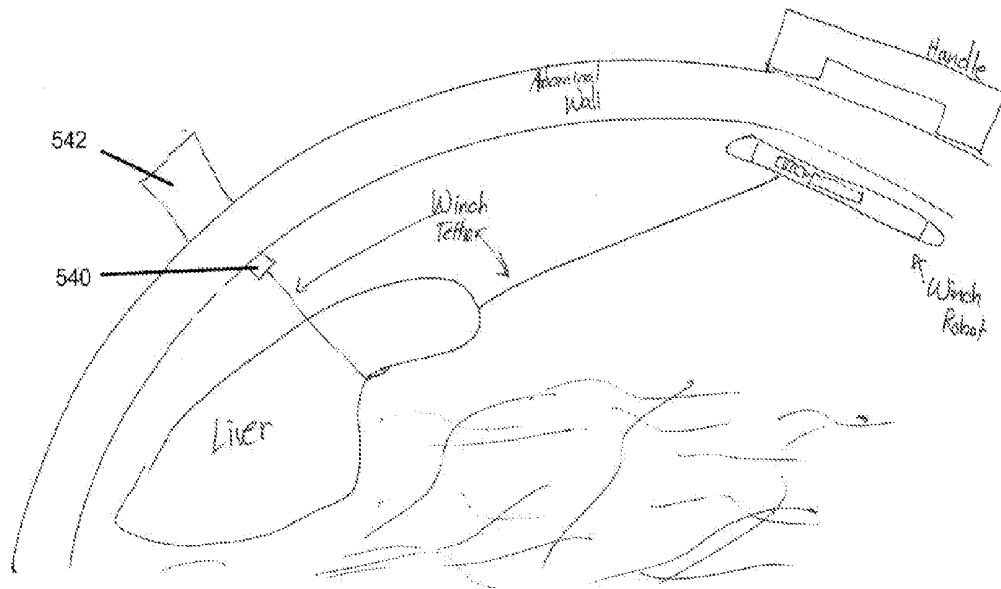

Figure 21

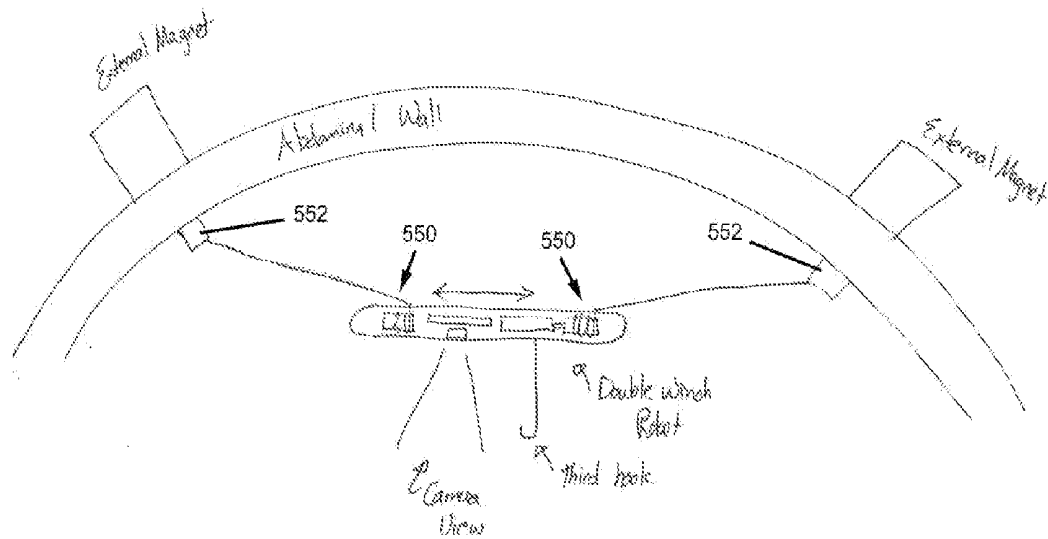

Figure 22

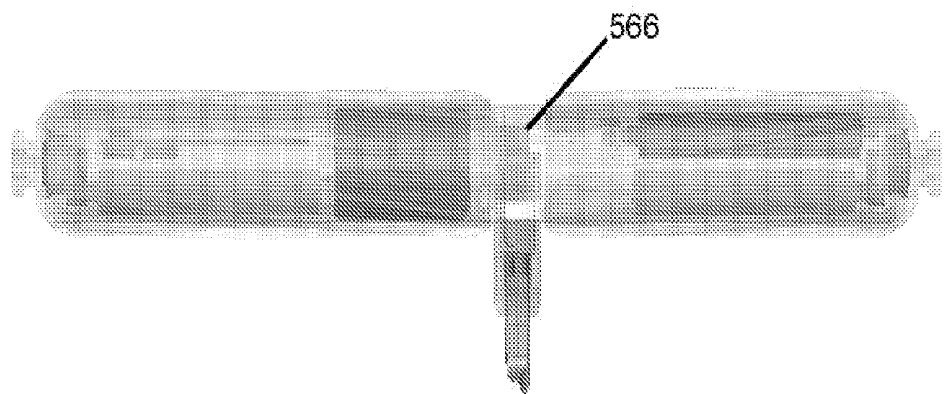

Figure 23A

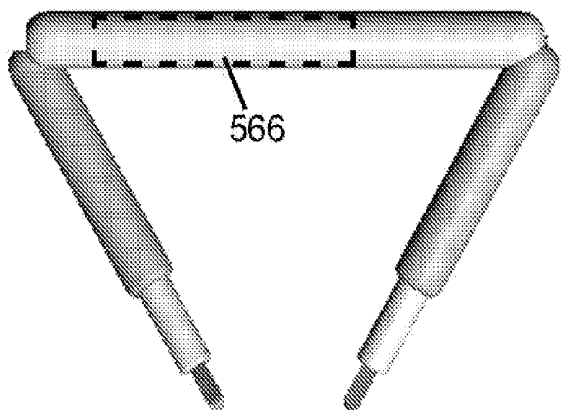

Figure 23B

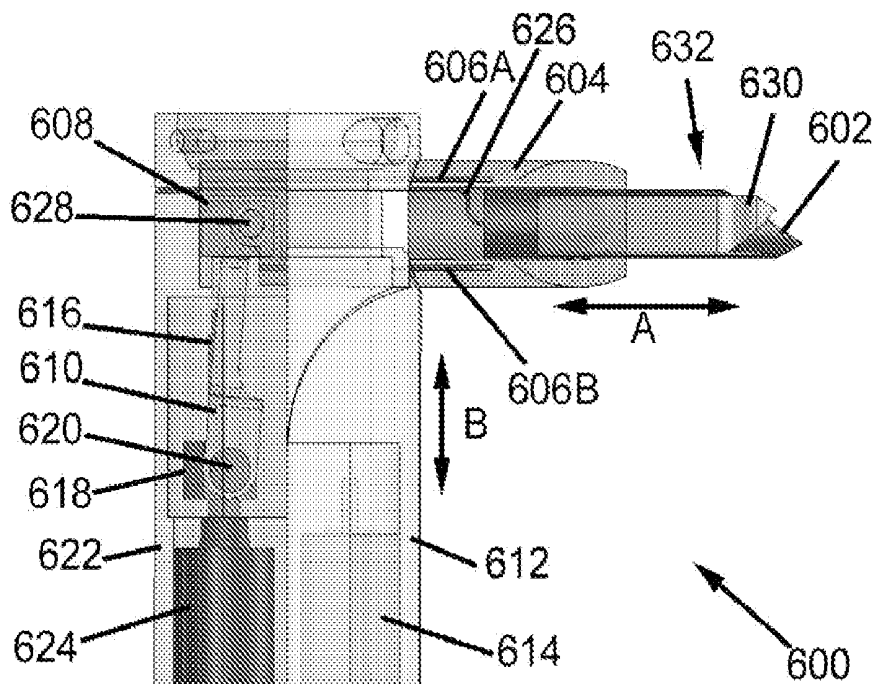

Figure 24A

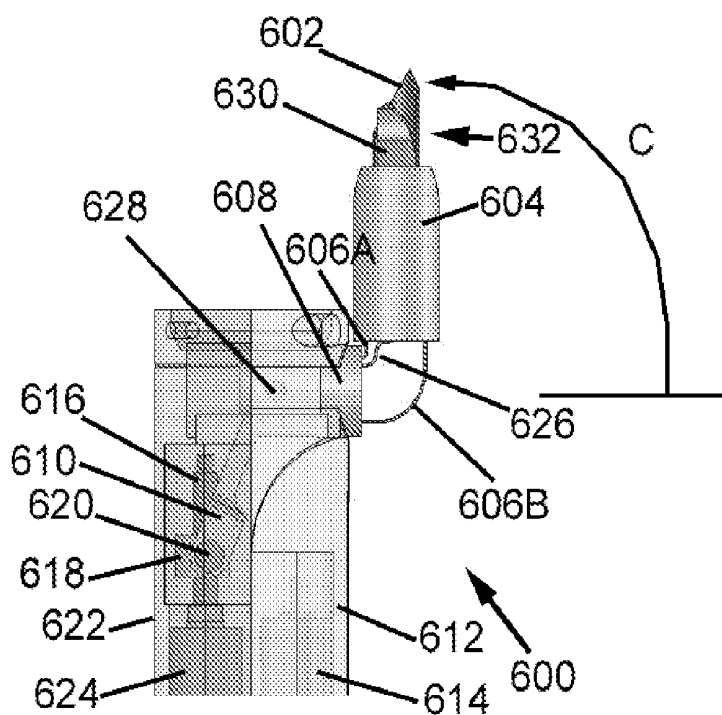

Figure 24B

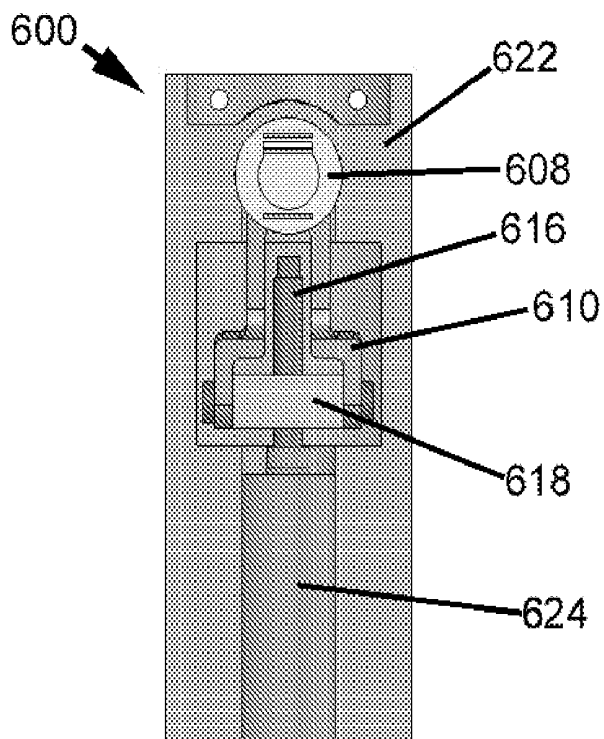

Figure 24C

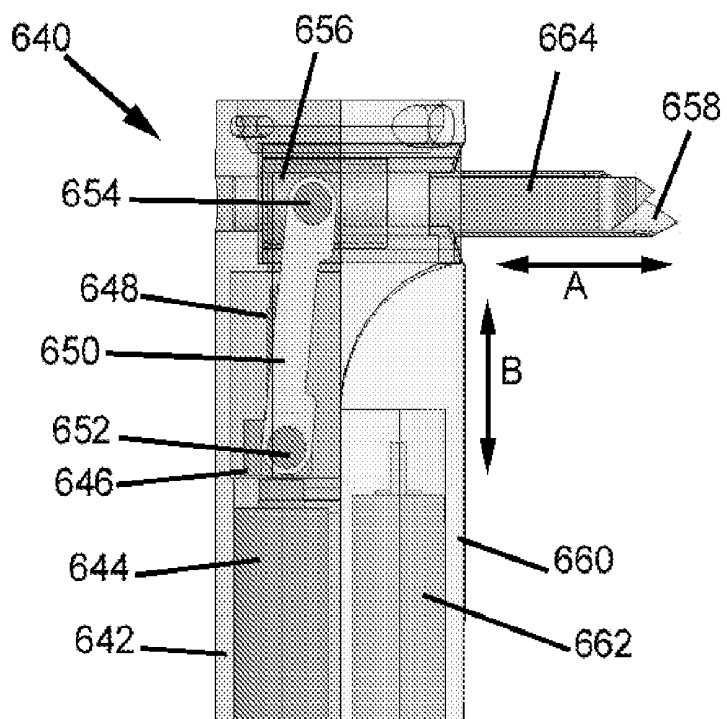

Figure 25A

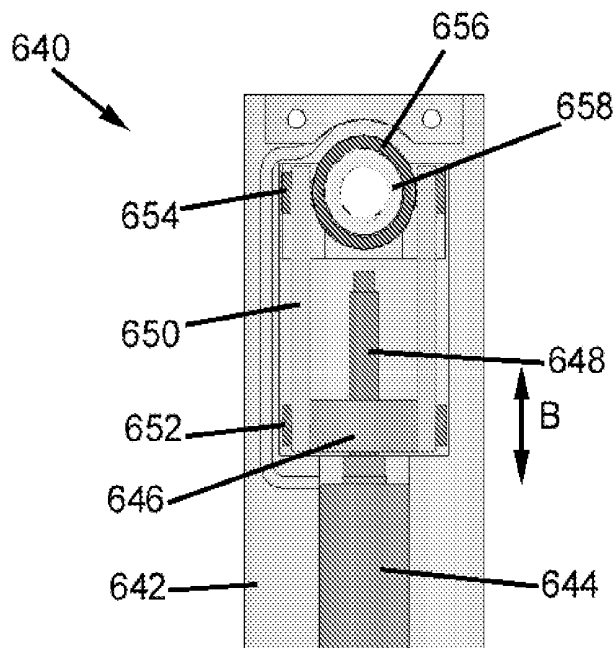

Figure 25B

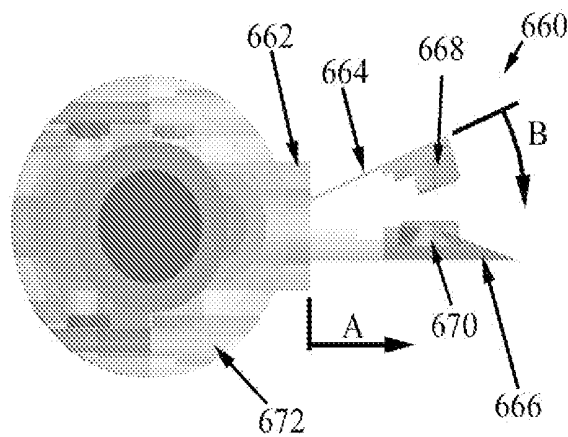

Figure 26

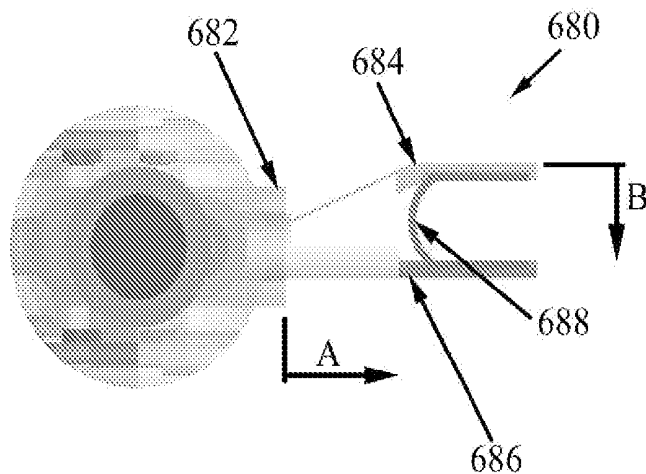

Figure 27

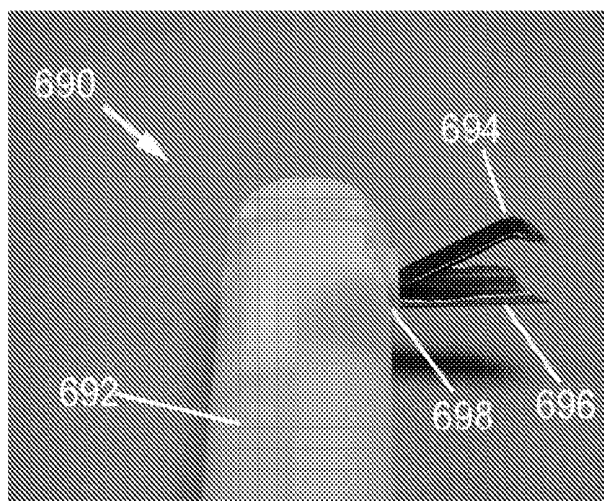

Figure 28A

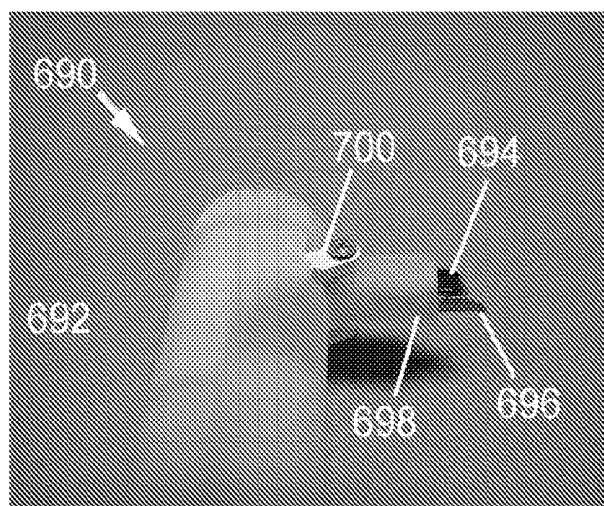

Figure 28B

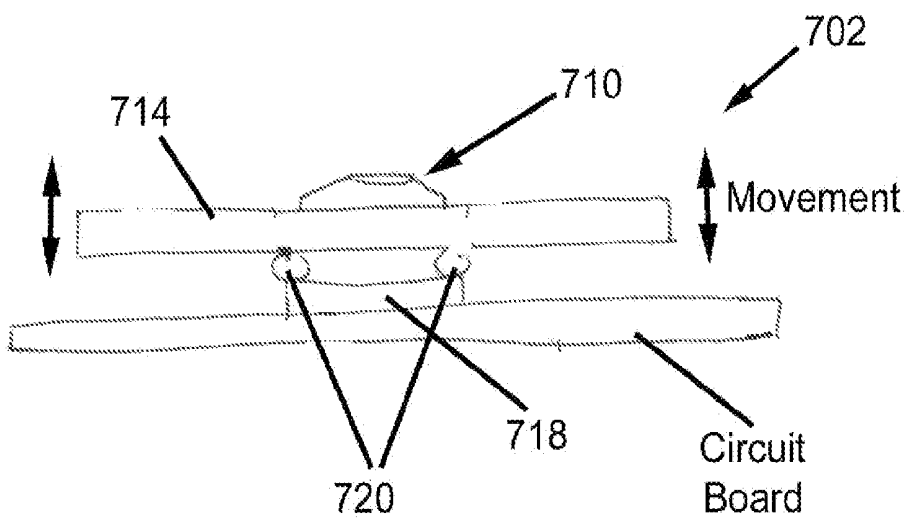

Figure 29A

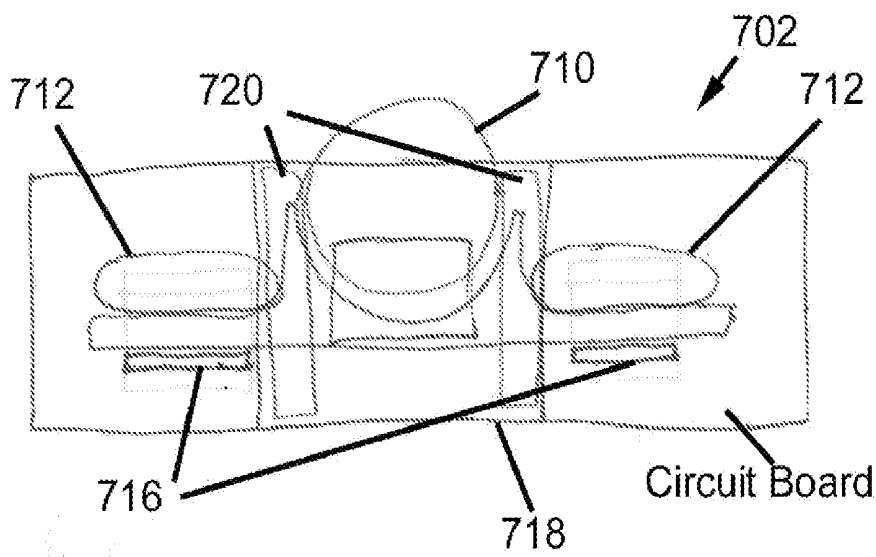

Figure 29B

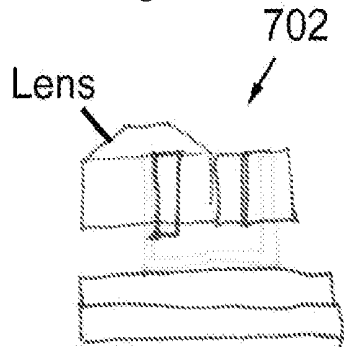

Figure 29C

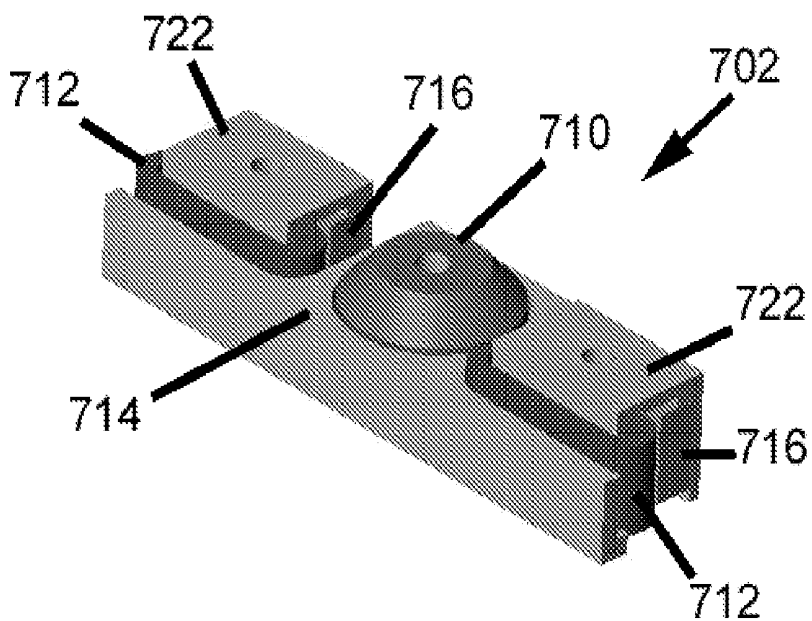

Figure 29D

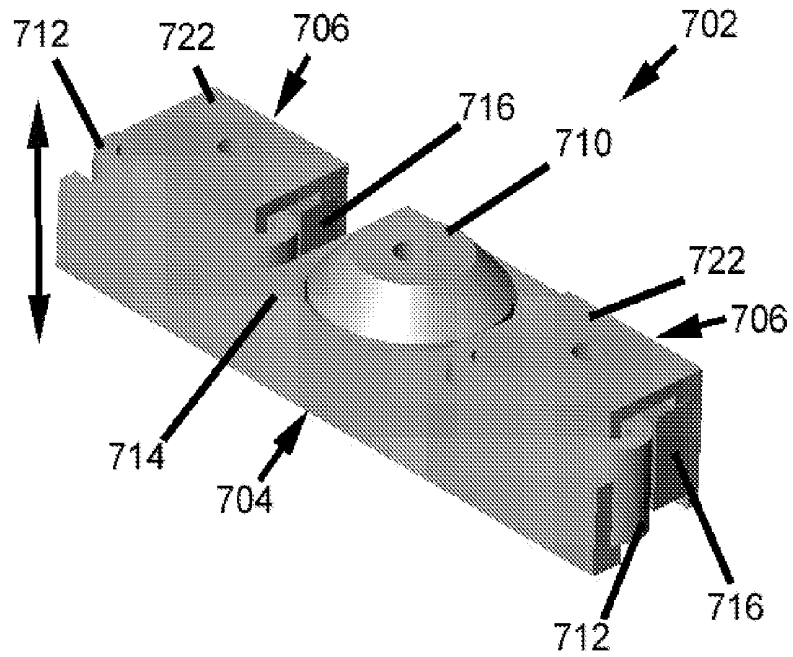

Figure 29E

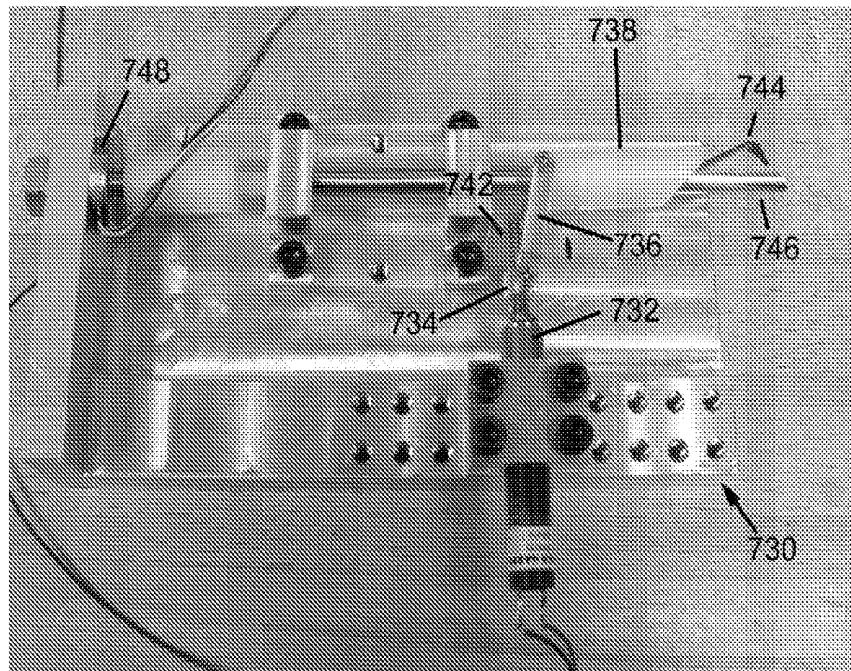

Figure 30A

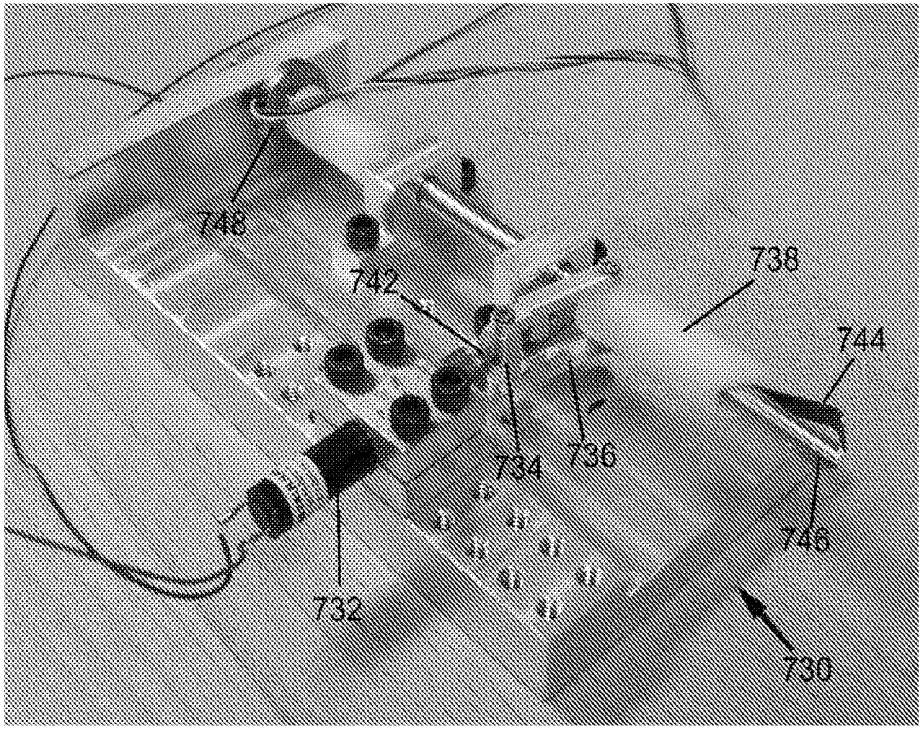

Figure 30B

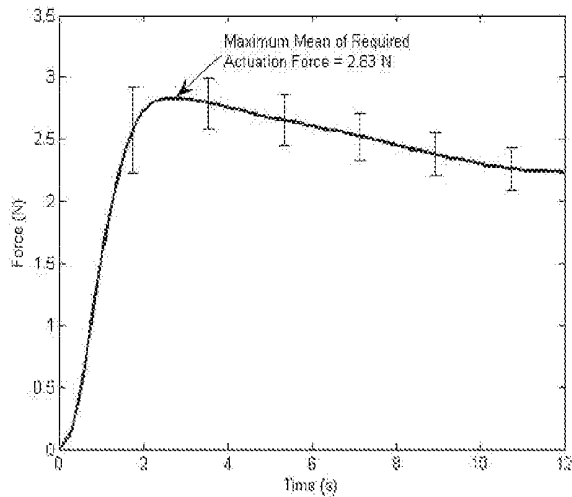

Figure 31

METHODS AND SYSTEMS OF ACTUATION IN ROBOTIC DEVICES

CROSS-REFERENCE TO RELATED APPLICATIONS

[0001] This application claims priority to Provisional Application No. 60/949,390, filed Jul. 12, 2007; Provisional Application No. 60/949,391, filed Jul. 12, 2007; Provisional Application No. 60/990,076, filed Nov. 26, 2007; and Provisional Application No. 61/025,346, filed Feb. 1, 2008, all of which are hereby incorporated herein by reference in their entireties.

GOVERNMENT SUPPORT

[0002] This invention was made with government support under Grant No. R21EB5663-2, awarded by the National Institute of Biomedical Imaging and Bioengineering within the National Institutes of Health. Accordingly, the government has certain rights in the invention.

TECHNICAL FIELD

[0003] The embodiments disclosed herein relate to various medical device components, including components that can be incorporated into robotic and/or in vivo medical devices. Certain embodiments include various actuation system embodiments, including fluid actuation systems, drive train actuation systems, and motorless actuation systems. Further embodiments include various operational components for medical devices, including medical device arm mechanisms, medical device winch mechanisms, medical device biopsy/stapler/clamp mechanisms, and medical device adjustable focus mechanisms. Other embodiments relate to reversibly lockable tube mechanisms.

BACKGROUND

[0004] Invasive surgical procedures are essential for addressing various medical conditions. When possible, minimally invasive procedures such as laparoscopy are preferred.

[0005] However, known minimally invasive technologies such as laparoscopy are limited in scope and complexity due in part to 1) mobility restrictions resulting from using rigid tools inserted through access ports, and 2) limited visual feedback. Known robotic systems such as the da Vinci® Surgical System (available from Intuitive Surgical, Inc., located in Sunnyvale, Calif.) are also restricted by the access ports, as well as having the additional disadvantages of being very large, very expensive, unavailable in most hospitals, and having limited sensory and mobility capabilities.

[0006] There is a need in the art for improved surgical methods, systems, and devices.

SUMMARY

[0007] One embodiment disclosed herein relates to a biopsy component having a substantially fixed jaw component, a mobile jaw component adjacent to the substantially fixed jaw component, and a sliding component configured to move between a first position and a second position. The mobile jaw component is predisposed to a position in which a distal end of the component is not in contact with the substantially fixed jaw component. Further, the sliding component in the second position is in contact with the mobile jaw

component such that the sliding component urges the distal end of the mobile jaw component toward the substantially fixed jaw component.

[0008] Another embodiment disclosed herein relates to an arm device having an extendable rotational arm, a first drive component, a second drive component, a first driven component, a second driven component, and a pin. The extendable rotational arm has an exterior portion having a first coupling component and further has a first aperture defined within the arm. The first drive component is coupled with the first driven component, and the first driven component has an inner surface having a second coupling component that is configured to be coupled with the first coupling component. The second drive component is coupled with the second driven component, and the second driven component has a second aperture defined within it. The pin is disposed within the first and second apertures. According to one embodiment, the first and second coupling components are threads. In a further embodiment, the first and second drive components and first and second driven components are gears. Alternatively, the first and second drive components and the first and second driven components are a pulley system or a friction drive system.

[0009] Yet another embodiment disclosed herein relates to a medical device having a body, a first winch component and an actuation component. The first winch component has a first drum and a first tether operably coupled to the first drum. In one embodiment, the actuation component is operably coupled to the first drum. In an additional embodiment, the device further has an end effector operably coupled to the distal end of the tether. In yet another implementation, the device also has a second winch component having a second drum and a second tether operably coupled to the second drum. According to a further embodiment, the device also has a third winch component having a third drum and third tether operably coupled to the third drum.

BRIEF DESCRIPTION OF THE DRAWINGS

[0010] FIG. 1A is a schematic depicting a fluid actuation system, according to one embodiment.

[0011] FIG. 1B is a schematic depicting a valve component, according to one embodiment.

[0012] FIG. 2A shows a front view of a medical device having a fluid actuation system, according to one embodiment.

[0013] FIG. 2BA depicts a front view of a medical device having a fluid actuation system, according to another embodiment.

[0014] FIG. 3 is a perspective view of a medical device, according to another embodiment.

[0015] FIG. 4 depicts a perspective view of a medical device joint, according to one embodiment.

[0016] FIG. 5 shows a perspective view of a medical device joint, according to another embodiment.

[0017] FIG. 6 is a perspective view of an operational component, according to one embodiment.

[0018] FIG. 7A depicts a front view of a medical device having a drive train system, according to one embodiment.

[0019] FIG. 7B shows a front view of a medical device having a drive train system, according to another embodiment.

[0020] FIG. 8 is a cutaway view of a reversibly lockable tube positioned in a target body cavity of a patient, according to one embodiment.

[0021] FIG. 9A depicts a perspective view of a modular tube component, according to one embodiment.

[0022] FIG. 9B shows another perspective view of the modular tube component of FIG. 9A.

[0023] FIG. 10 is a front view of a reversibly lockable tube, according to one embodiment.

[0024] FIG. 11 depicts a perspective view of the reversibly lockable tube of FIG. 10.

[0025] FIG. 12 shows a perspective view of a reversibly lockable tube, according to another embodiment.

[0026] FIG. 13 is a perspective view of a reversibly lockable tube, according to yet another embodiment.

[0027] FIG. 14A depicts a front view of a medical device having a motorless actuation component, according to one embodiment.

[0028] FIG. 14B shows a side view of the medical device of FIG. 14A.

[0029] FIG. 15 is a front view of a medical device having a motorless actuation component, according to another embodiment.

[0030] FIG. 16 depicts a perspective view of a medical device having an arm component, according to one embodiment.

[0031] FIG. 17A shows a perspective view of an arm component, according to one embodiment.

[0032] FIG. 17B is a perspective exploded view of the arm component of FIG. 17A.

[0033] FIG. 18 depicts a perspective view of an arm component, according to another embodiment.

[0034] FIG. 19A shows a perspective view of a medical device having a winch component, according to one embodiment.

[0035] FIG. 19B is a front view of the medical device having the winch component of FIG. 19A.

[0036] FIG. 20 depicts a cutaway view of a medical device utilizing a winch component during a procedure in a patient, according to one embodiment.

[0037] FIG. 21 shows a cutaway view of a medical device utilizing a winch component during a procedure in a patient, according to another embodiment.

[0038] FIG. 22 is a cutaway view of a medical device utilizing two winch components during a procedure in a patient, according to yet another embodiment.

[0039] FIG. 23A depicts a front view of a medical device having a payload area that is a biopsy mechanism, according to one embodiment.

[0040] FIG. 23B shows a front view of a medical device having a payload area, according to another embodiment.

[0041] FIG. 24A is a side view of a modular biopsy mechanism, according to one embodiment.

[0042] FIG. 24B depicts another side view of the modular biopsy component of FIG. 24A.

[0043] FIG. 24C shows a front view of the modular biopsy mechanism of FIGS. 24A and 24B.

[0044] FIG. 25A is a side view of a modular biopsy mechanism, according to another embodiment.

[0045] FIG. 25B depicts a front view of the modular biopsy mechanism of FIG. 25A.

[0046] FIG. 26 shows a top view of a biopsy mechanism, according to another embodiment.

[0047] FIG. 27 is a top view of another biopsy mechanism, according to yet another embodiment.

[0048] FIG. 28A depicts a perspective view of another biopsy mechanism, according to a further embodiment.

[0049] FIG. 28B shows a perspective view of the biopsy mechanism of FIG. 28A.

[0050] FIG. 29A is a side view of an adjustable focus component, according to one embodiment.

[0051] FIG. 29B depicts a top view of the adjustable focus component of FIG. 29A.

[0052] FIG. 29C shows an end view of the adjustable focus component of FIGS. 29A and 29B.

[0053] FIG. 29D is a perspective view of the adjustable focus component of FIGS. 29A, 29B, and 29C.

[0054] FIG. 29E depicts a perspective view of the adjustable focus component of FIGS. 29A, 29B, 29C, and 29D.

[0055] FIG. 30A shows a top view of a laboratory test jig used to measure forces applied by a biopsy mechanism, according to one embodiment.

[0056] FIG. 30B is a perspective view of the test jig and biopsy mechanism of FIG. 30A.

[0057] FIG. 31 depicts a line graph relating to data collected from the operation of the test jig depicted in FIGS. 30A and 30B.

DETAILED DESCRIPTION

[0058] The various systems and devices disclosed herein relate to devices for use in medical procedures and systems. More specifically, the various embodiments relate to various actuation or end effector components or systems that can be used in various procedural devices and systems.

[0059] It is understood that the various embodiments of actuation, end effector, and other types of device components disclosed herein can be incorporated into or used with any known medical devices, including, but not limited to, robotic or in vivo devices as defined herein.

[0060] For example, the various embodiments disclosed herein can be incorporated into or used with any of the medical devices disclosed in copending U.S. application Ser. No. 11/932,441 (filed on Oct. 31, 2007 and entitled "Robot for Surgical Applications"), Ser. No. 11/695,944 (filed on Apr. 3, 2007 and entitled "Robot for Surgical Applications"), Ser. No. 11/947,097 (filed on Nov. 27, 2007 and entitled "Robotic Devices with Agent Delivery Components and Related Methods"), Ser. No. 11/932,516 (filed on Oct. 31, 2007 and entitled "Robot for Surgical Applications"), Ser. No. 11/766,683 (filed on Jun. 21, 2007 and entitled "Magnetically Coupleable Robotic Devices and Related Methods"), Ser. No. 11/766,720 (filed on Jun. 21, 2007 and entitled "Magnetically Coupleable Surgical Robotic Devices and Related Methods"), Ser. No. 11/966,741 (filed on Dec. 28, 2007 and entitled "Methods, Systems, and Devices for Surgical Visualization and Device Manipulation"), 60/949,391 (filed on Jul. 12, 2007), 60/949,390 (filed on Jul. 12, 2007), 60/990,062 (filed on Nov. 26, 2007), 60/990,076 (filed on Nov. 26, 2007), 60/990,086 (filed on Nov. 26, 2007), 60/990,106 (filed on Nov. 26, 2007), 60/990,470 (filed on Nov. 27, 2007), 61/025,346 (filed on Feb. 1, 2008), 61/030,588 (filed on Feb. 22, 2008), and 61/030,617 (filed on Feb. 22, 2008), all of which are hereby incorporated herein by reference in their entireties.

[0061] In an exemplary embodiment, any of the various embodiments disclosed herein can be incorporated into or used with a natural orifice transluminal endoscopic surgical device, such as a NOTES device. Those skilled in the art will appreciate and understand that various combinations of features are available including the features disclosed herein together with features known in the art.

[0062] Certain device implementations disclosed in the applications listed above can be positioned within a body cavity of a patient, including certain devices that can be positioned against or substantially adjacent to an interior cavity wall, and related systems. An “in vivo device” as used herein means any device that can be positioned, operated, or controlled at least in part by a user while being positioned within a body cavity of a patient, including any device that is positioned substantially against or adjacent to a wall of a body cavity of a patient, further including any such device that is internally actuated (having no external source of motive force), and additionally including any device that may be used laparoscopically or endoscopically during a surgical procedure. As used herein, the terms “robot,” and “robotic device” shall refer to any device that can perform a task either automatically or in response to a command.

[0063] Certain embodiments disclosed herein relate to actuation components or systems that are configured to provide motive force to any of the various procedural device embodiments described above. One such embodiment is a fluid actuation system. FIG. 1A schematically depicts one embodiment of a fluid actuation system 10 for a procedural device. According to one implementation, the fluid actuation system 10 is a hydraulic system. Alternatively, the fluid actuation system 10 is a pneumatic system. In a further alternative, the fluid actuation system can be any known such system. Hydraulic systems are generally preferred for higher power transmission, while pneumatic systems can be a good actuation system for binary actuation, such as actuation required for a grasper. In the hydraulic embodiment depicted in FIG. 1A, the system 10 includes a medical device 12 that is connected via a hydraulic connection line 20 to external hydraulic components 22. The device 12 as shown has a hydraulic piston assembly 14 having a piston 16 positioned within a cylinder 18. The piston assembly 14 can be used for any actuation associated with the device 12, such as powering movement of the device 12 in relation to the patient's body, actuating a component of the device to perform an action, or any other desired actuation.

[0064] As further shown in FIG. 1A, the piston assembly 14 is connected via a hydraulic connection line 20 to the external hydraulic components 22, which include a reservoir 24, a pump 26, and an accumulator 28. The external hydraulic components 22 are positioned at a location external to the patient's body. Thus, the hydraulic connection line 20 is connected to the piston assembly 14 in the device 12 through the valve component 30 and to the external hydraulic components 22 such that the line 20 extends from the interior of the patient's body to the exterior when the device 12 is positioned in the patient's body. According to one embodiment, the line 20a that couples the accumulator 28 to the valve component 30 is a high pressure supply line 20a that provides fluid to the valve component 30 under high pressure. In accordance with a further implementation, the line 20b that couples the valve component 30 to the reservoir 24 is a low pressure supply line 20b that allows fluid to move from the valve component 30 to the reservoir 24 under low pressure.

[0065] In one embodiment, the hydraulic fluid used in the hydraulic system 10 is saline solution. Alternatively, the fluid is water-based. In a further alternative, the hydraulic fluid can be any fluid that is non-toxic, biocompatible, and less compressible as required to provide sufficient precise control.

[0066] In one implementation, the external hydraulic components 22 are the reservoir 24, pump 26, and accumulator 28

as discussed above, which operate in known fashion to hydraulically power the piston assembly 14. In one example, the pump 26 used in this system is a commercially-available surgical irrigation pump, while the accumulator 28 and reservoir 24 are commercially available from Parker Hannifin, which is located in Cleveland, Ohio. Alternatively, the external hydraulic components 22 can be any known configuration of any hydraulic components capable of hydraulically powering the piston 16.

[0067] According to one implementation of a fluid actuation system, the piston 16 is a standard syringe handle and the cylinder 18 is the syringe body. Alternatively, the piston assembly 14 can be a small commercially available system used for model airplane landing gear. In a further embodiment, the piston 16 is custom machined with an o-ring around the piston head, while the cylinder 18 is a machined or molded cavity within the robot's base or arms.

[0068] The valve component 30 has a valve for each piston assembly 14. Thus, the valve component 30 may have anywhere from one valve to any number equal to the maximum number of valves provided in the system.

[0069] Another example of a valve component 32 is provided in FIG. 1B. In this embodiment, the component 32 has six valves 34. The fluid is provided at high pressure through the high pressure supply line 36a and exits the valve component 32 at a low pressure through the low pressure line 36b. In addition, the valves 34 are each coupled to a respective piston assembly 38 as shown. According to one embodiment, such a valve component 30 (also referred to as a “valve system”) is sold by Parker Hannifin.

[0070] As mentioned above, the fluid actuation systems depicted in FIGS. 1A and 1B can alternatively be a pneumatic system. Returning to FIG. 1A, in this embodiment of a pneumatic system 10, the external pneumatic components 22 are disposed externally to the patient's body. Thus, the pneumatic connection line 20 is connected to the valve component 30 in the medical device 12 and to the external pneumatic components 22 such that the line 20 extends from the interior of the patient's body to the exterior when the device 12 is positioned in the patient's body.

[0071] According to one embodiment of a pneumatic system, in place of the pump 26, accumulator 28, and reservoir 24, the external pneumatic component 22 is a pressurized cylinder (not shown). In this embodiment, the return air is emitted into the external environment of the system. One example of a pressurized cylinder is a canister of readily-available carbon dioxide, which is commonly used to insufflate the abdominal cavity during laparoscopic surgery. Alternatively, the external pneumatic components 22 can be any known configuration of any pneumatic components capable of pneumatically powering the piston 16.

[0072] FIGS. 2A and 3 depict a robotic device 40 with a hydraulic system, according to one embodiment. The device 40 has six piston assemblies 42a, 42b, 42c, 42d, 42e, 42f. Piston assemblies 42a and 42b are disposed within the body 44 of the device 40 and actuate the first links 48a, 48b of the robotic arms 46a, 46b. Piston assemblies 42c, 42d are disposed within the first links 48a, 48b and actuate the second links 50a, 50b. In addition, piston assemblies 42e, 42f are disposed within the second links 50a, 50b and actuate the operational components 52, 54.

[0073] Alternatively, the device 40 can have from one to any number of piston assemblies that can be integrated into

the robotic device as actuation components. According to one embodiment, a piston is provided for each degree of freedom.

[0074] According to one embodiment as shown in FIG. 2B, the external components of the hydraulic system 56 provide a high pressure supply line 57a to the robotic device and receive a low pressure return line 57b from the device. In a further embodiment, the robotic device has a system of valves or a master valve system 58 that controls the hydraulic fluid flow and directs the fluid as needed to the piston assemblies, such as the assemblies depicted in FIGS. 2A and 3.

[0075] FIG. 4 depicts a robotic device joint 60 connecting a link 62 to the robotic body 64, according to one embodiment. The body 64 has a piston assembly 66 in which the piston 68 is coupled to a pin 70 that is coupled in turn to the link 62 at the connection point 72. In one implementation, the link 62 is a first link 62 such that the joint 60 is a joint 60 between a robotic body 64 and a first link 62 (also referred to as a "shoulder joint").

[0076] FIG. 5 depicts a robotic device joint 80 connecting a first link 82 to a second link 84, according to one embodiment. The first link 82 has a piston assembly 86 in which the piston 88 is coupled to a pin 90 that is coupled in turn to the second link 84 at the connection point 92. In one implementation, the joint 80 between the two links 82, 84 is referred to as an "elbow joint."

[0077] FIG. 6 depicts an operational component 100 coupled to a robotic arm 102, according to one embodiment. The robotic arm 102 has a piston assembly 104 in which the piston 106 is coupled to a portion of the operational component 100. More specifically, the piston 106 is coupled to a sliding component 108 at a connection point 110, wherein the sliding component is slidably positioned in the arm 102 such that the force created by the piston assembly 104 is translated to the sliding component 110, causing the sliding component 110 to slide back and forth in the arm 102.

[0078] The operational component 100 is coupled to the sliding component 110 at joint 112 such that the sliding back and forth of the sliding component 110 causes the operational component 100 to extend and retract relative to the arm 102. This allows for the lengthening and shortening of the reach of the operational component 100 with respect to the arm 102 and the procedural space in which the operational component 100 is operating. Stated in another way, according to one embodiment, this slidable coupling of the sliding component 110 and the arm 102 is considered to be the "wrist" of the arm 102, wherein the sliding of the sliding component 110 back and forth operates to lengthen and shorten the "wrist" in relation to the rest of the arm 102.

[0079] In one embodiment, an actuator (not shown) disposed in the sliding component 108 actuates the operational component 100. For example, in the embodiment depicted in FIG. 6 in which the operational component 100 is a set of graspers 100, the actuator actuates the graspers to move between the open and closed positions.

[0080] It is understood that a pneumatic system could be incorporated into any of the embodiments and components depicted in FIGS. 2A, 2B, and 3-6 and could operate in generally the same fashion as discussed above. It is further understood that any other type of fluid actuation system could also be implemented in any of these embodiments in generally the same fashion.

[0081] In accordance with one implementation, a device having a fluid actuation system such as the various systems disclosed herein could reduce costs associated with the

device. That is, the components of the system associated with the device can be integrated into the device at a low cost (in comparison to devices having costly onboard motors, etc.), while the more expensive components can be incorporated into the external components of the system and thus can be re-used for extended periods of time. In another embodiment, the use of a fluid actuation system in a device can provide increased force and/or speed in comparison to internal motors.

[0082] In a further alternative embodiment, the device is a "hybrid" that has at least one piston and at least one motor, thereby providing for further flexibility in the configuration of the device and the capability of accomplishing very precise motions. For example, the precise motions could include motions of the wrist such as rotation or extension that might require very precise control for delicate tissue dissection. In such an embodiment, the fluid actuation piston assemblies could be used for purposes of gross and/or quick actuations that require greater power, such as actuation of the shoulder and/or elbow joints, while the motor assemblies could be used for purposes of precise, slower actuations, such as actuation of the wrist or operational component for precise tasks such as dissection. In this context, the fluid actuation assemblies of the shoulder and elbow joints could then subsequently be used for the pulling or cutting motions that require greater power.

[0083] In addition to the fluid actuation systems described above, yet another actuation system that can be implemented with the various medical devices disclosed or incorporated herein is a drive train system. One exemplary implementation of a drive train system is shown in FIG. 7A, which depicts a robotic device 202 mechanically powered or actuated with a drive train system 200. The system 200 has a drive component 204 that is coupled to the robotic device 202 and thereby provides mechanical force to the device 202.

[0084] In one embodiment as shown in FIG. 7B, the drive component 204 includes a series of axles and couplers that are connected to each other and to an actuation component 212 (which, according to one implementation, can be a drive motor 212) and ultimately are connected to the device 202. More specifically, the drive component 204 includes the drive shaft 214, the first coupling component 215, the second coupling component 216, the connecting shaft 217, and the third coupling component 218. According to one embodiment, the first, second, and third coupling components 215, 216, 218 are coupleable gears. In operation, the actuation component 212 depicted in FIG. 7B powers the drive component 204 by actuating the drive shaft 214. The rotation of drive shaft 214 powers the rotation of the connecting shaft 217 via the first and second coupleable gears 215, 216. The power is then transferred to the medical device 202 via the third gear 218.

[0085] Alternatively, the drive component 204 is a flexible rod that is capable of transferring rotational power to the device 202. In a further embodiment, the drive component 204 is any known drive component capable of transferring power to a robotic device 202.

[0086] As shown in FIGS. 7A and 7B, this particular embodiment relates to a drive component 204 that is positioned inside a needle, port, or other kind of insertion component 206 that is connected to a device 202 positioned inside the patient's body. Alternatively, the insertion component 206 is an opening or channel that provides for access or connection to the device 202 inside the patient's body. More specifically, in the embodiment depicted in FIG. 7, the insertion

component **206** is a trocar-like port **206** that is inserted through an incision **208** in the patient, such as an incision **208** through the abdominal wall **210**. The drive component **204** is then positioned within the port **206** and coupled to the device **202** positioned in the patient's body cavity.

[0087] As described above, the drive component **204** can be a rotary shaft **204** that supplies rotational actuation to the device **202**. In one exemplary implementation, the shaft **204** has a series of clutches (not shown) that transfer the actuation to the piston assemblies or other translation assemblies for actuation of the joints and other actuatable components. The miniature clutches are common components that are available commercially from Small Parts, Inc., located in Miami Lakes, Fla. In one embodiment, the clutches are operated hydraulically. Alternatively, the clutches are operated electrically or by any other known method.

[0088] In a further alternative implementation, the drive component **204** winds one or more onboard tensionable springs that can then be used to provide power to the end effectors or other drivable/driven components in the device through a clutch system.

[0089] Alternatively, the rotary shaft **204** is a flexible rod **204**. In this embodiment, the insertion component **206** does not necessarily need to be straight. In one example, the insertion component **206** is inserted through the esophagus of the patient and into the abdominal cavity through an incision in the stomach wall. The inner flexible rod **204** is positioned within the insertion component **206** and coupled to the robotic device **202**. In this example, the flexible rod **204** is rotated to provide rotational actuation to the robotic device **202**.

[0090] One component that can be used in conjunction with any fluid actuation or drive train actuation system such as those systems described above is a reversibly lockable tube. As used herein, "reversibly lockable tube" is intended to mean any tubular component that can be switched, adjusted, or otherwise changed between a flexible configuration and a locked configuration (in which "locked" is intended to encompass any level of substantial rigidity). This adjustability between flexible and rigid configurations shall also be referred to herein as the "reversibly lockable" feature. Please note that the term "tube" as used herein is intended to encompass any tubular or hose-like component that provides access to various cavities of a patient's body for medical procedure devices and/or connection to such devices positioned in the patient's body.

[0091] FIG. 8 provides one exemplary depiction of an embodiment of a reversibly lockable tube **220** coupled to a robotic device **222** that is positioned in the target body cavity of the patient. As discussed above, one embodiment of the tube **220** can be adjusted between a flexible configuration and a rigid or "locked" configuration. In use, such components as a hydraulic or pneumatic actuation system as described above can be disposed within the tube **220**, along with any other components that connect a robotic device disposed within the patient's body with components positioned externally to the patient's body. More specifically, the tube **220** is maintained in its flexible configuration while the tube **220** is being positioned through an orifice into a patient's body such as through the mouth and esophagus of the patient as depicted in FIG. 8. Once the tube **220** has been positioned, the tube **220** can be adjusted into the locked configuration during operation of the

device **222**. The operation of the various lockable tube embodiments disclosed herein will be described in further detail below.

[0092] FIGS. 10 and 11 depict a reversibly lockable tube **240** according to one embodiment that is made up of multiple modular tube components (also referred to herein as "links").

[0093] One example of modular tube components **260** (such as those used in the tube **240** shown in FIGS. 10 and 11) is depicted in FIGS. 9A and 9B. FIG. 9A depicts the male end **262** (or "protrusion"), while FIG. 9B depicts the female end **264**. As shown in FIG. 9A, the male end **262** is a convex protrusion. Alternatively, the male end **262** can be any form of protrusion that mates with the female end **264**. As shown in FIG. 9B, the female end **264** is a concave formation. Alternatively, the female end **264** can take any form or configuration that mates with the male end **262**.

[0094] As shown in FIGS. 9A and 9B, each modular component **260** has at least one hole **268** (also referred to herein as a "channel") defined through the component **260**. As depicted, the component **260** has three channels **268**, **270**, **272**. According to one embodiment, the channels **268**, **270**, **272** are configured to receive and/or allow the passage of any cables or tubes that are to be inserted through or positioned within the reversibly lockable tube **240**, such as those shown in FIGS. 10 and 11. In accordance with one implementation, the center channel **268** is configured to receive a rigidity cable **242**, best shown in FIGS. 10 and 11. The rigidity cable **242** is used to convert or adjust the tube **240** into the rigid configuration or phase. Any additional channels, such as channels **270**, **272**, are configured to receive electrical connection components, hydraulic or pneumatic tubes, or any other elongate members that require insertion into the target cavity or connection to a robotic device positioned in the target cavity.

[0095] According to one embodiment as best shown in FIGS. 10, 11, and 12, the rigidity cable **242** operates in the following manner to adjust or convert the tube **240** from the flexible configuration to the rigid configuration. In the flexible state as shown in FIG. 11, the cable **242** is allowed to be loose and thus the modular components **246** are not being urged against each other into a tight configuration. According to one embodiment, each modular component **246** can move about 20 degrees relative to the adjacent components **246** in the flexible state. When it is desirable to adjust or transform the tube **240** from the flexible state to the rigid state, the cable **242** is pulled or otherwise urged at its proximal end **248** in a direction away from the tube **240**. This causes the cable end **244** to contact the distal modular component **250** and begin urging that component **250** toward the other components of the tube **240**. Ultimately, this urges the modular components **246** into a tight configuration of the components **246** in which each of the components **246** is stacked tightly, or is otherwise in close contact, with the other components **246**, thereby resulting in a substantially rigid configuration of the tube **240**.

[0096] In use, the tube (such as tubes **220** or **240**, for example) is placed in its flexible configuration or state for insertion of the robotic device into the patient's body. Once the device has been positioned as desired by the user (such as the positioning of the device **222** and tube **220** depicted in FIG. 8 or alternatively as shown in FIG. 13), the tube is then adjusted or converted or otherwise placed into its rigid configuration or phase. This rigidity can assist in maintaining the geometric or physical shape and/or positioning of the tube in relation to the patient and resist against the straightening force of the hydraulic, pneumatic, or physical force being applied

through the connections between the device and the external components of the hydraulic, pneumatic, or drive train systems, respectively, as known in the art or as described above. Thus, the tube can assist in maintaining the stability of the robotic device during use. Alternatively, the rigidity can assist with maintaining the geometric or physical shape and/or positioning of the tube for any reason that may benefit the operation of the medical device or the medical procedure generally.

[0097] In addition to the fluid actuation system and drive train embodiments discussed above, yet another actuation component that can be incorporated into or used with any of the medical devices disclosed or otherwise described herein is a motorless actuation system or component.

[0098] FIGS. 14A and 14B depict one embodiment of a motorless actuation component. More specifically, FIGS. 14A and 14B depict a robotic camera device 310, according to one embodiment, in which the robotic device 310 is disposed within the abdominal cavity of a patient, and a magnetic handle 312 is disposed at a location external to the patient. The handle 312 operates to hold the device 310 inside the abdominal cavity against the peritoneum (abdominal wall) via magnetic forces.

[0099] It is understood that this embodiment is similar to the embodiments disclosed in U.S. patent application Ser. No. 11/766,720, filed on Jun. 21, 2007, and U.S. patent application Ser. No. 11/766,683, filed on Jun. 21, 2007, both of which were incorporated herein above. It is further understood that any of the instant motorless actuation component embodiments can be incorporated into any of the embodiments disclosed in those co-pending applications.

[0100] In the implementation shown in FIGS. 14A and 14B, the device 310 is cylindrical and includes an imaging component 314, a lighting component 316, magnets 318 at each end of the device, and a wired connection component 320 (also referred to herein as a “wire tether”). The magnets 318 are magnetically coupleable with magnets 322 on the handle 312 such that the device 310 is urged toward and held against the body cavity wall. In one embodiment, the magnets 318 are configured to ensure that the imaging component 314 is positioned to capture a view of the body cavity or the target area of interest.

[0101] It is understood that the magnets 318 in the device 310 and those magnets 322 in the handle 312 can be positioned in any configuration and include any number of magnets as disclosed in the U.S. patent application Ser. Nos. 11/766,720 and 11/766,683, incorporated herein.

[0102] It is further understood that, in one embodiment, the magnetic handle 312, also referred to herein as an “external magnet,” is in the shape of a handle. Alternatively, the handle 312 is intended to encompass any magnetic component that is magnetically coupleable with any robotic device as described herein such that the magnetic component can be used to position, operate, or control the device.

[0103] In one embodiment as described in the incorporated references above, the handle 312 can be rotated as shown by arrow 342 to allow a tilting functionality for the imaging component. Further, the device can also provide for a panning functionality via rotation of the imaging component as shown by arrow 344, as described in further detail below.

[0104] In use, the device 310 can be moved within the patient's body to any desired position by moving the handle 312 outside the body. Alternatively, the device 310 can be positioned, operated, or controlled anywhere in a patient's

body at least in part by the magnetic handle 312 positioned outside the body in any fashion described in the references incorporated above.

[0105] According to one implementation, the robotic device 310 shown in FIGS. 14A and 14B has two portions: an inner portion 330 and an outer portion 332, as best shown in FIG. 14B. The inner portion 330, according to one embodiment, is a cylindrically shaped inner body 330, and the outer portion 332 is an outer sleeve 332 configured to be rotatably disposed over the inner body 330. In such an embodiment, the imaging component 314 and lens 315 can be panned by rotating the inner body 330 with respect to the sleeve 332, causing the lens 315 to rotate in a fashion similar to that depicted by the arrow 344. In accordance with one implementation, the inner body 330 is coupled to the outer sleeve 332 with a set of bearings (not shown).

[0106] In one implementation, the actuation component 334 that rotates the inner portion 330 relative to the outer portion 332 is a motorless actuation component. That is, the actuation component is not a motor or a motorized component of any kind. For example, the actuation component 334 as shown in FIGS. 14A and 14B includes a race 336 and ball 338. In this embodiment, a magnet 340 external to the patient is used to urge the ball 338 along the race 336. In such an embodiment, the magnet 340 can be coupled with the magnetic handle 312 described here as shown in FIG. 14A. In one embodiment, the race 336 is helical and the ball 338 is steel. In a race and ball implementation, as the ball 338 moves along the race channel 336, the inner body 330 rotates relative to the outer sleeve 332. In another embodiment, the ball 338 is magnetic and moves along a race 336.

[0107] FIG. 15 depicts an alternative embodiment of a motorless actuation component in which the actuation component 352 has multiple magnets 354 that are disposed in or on the robotic device 350. In this embodiment, the magnets 354 are placed in a helical pattern in the inner cylinder (not shown) so that as the external magnet 356 is translated, the inner body rotates relative to the outer sleeve 358 as the inner body magnet 354 in closest proximity to the external magnet 356 is urged toward the external magnet 356. In another embodiment, a series of electromagnets in the handle 360 can be actuated in order to move the effective magnetic field along the handle 360.

[0108] In yet another alternative embodiment, the ball can be urged along the race by other means. For example, the device can have a cable or wire connected to it and also connected to an external handle. Actuation of this cable urges the ball along the race, thereby resulting in a panning motion of the inner body relative to the outer sleeve. In one embodiment, the cable is attached or operably coupled in some fashion to the ball so that actuation of the cable urges the ball along the race.

[0109] In a further alternative, the motorless actuation component does not include a ball and race, but instead has a drum. In this embodiment, a cable such as that described above is attached to the drum so that actuation of the cable urges the drum to rotate. This rotation of the drum causes rotational actuation in the medical device. Alternatively, any known method of transitioning translation motion into rotary motion could be used. Further, it is understood that any known motorless actuation component can be incorporated into any of the medical devices described herein or incorporated by reference herein.

[0110] Various mechanical arm embodiments are provided herein that can be incorporated into any number of different kinds of medical devices. The medical device arm configurations disclosed herein provide for various arm embodiments having two degrees of freedom—both (1) axial movement (extension and retraction of a portion of the arm along the longitudinal axis of the arm), and (2) rotational movement around the axis of the arm. These configurations provide for the two degrees of freedom while maintaining a relatively small or compact structure in comparison to prior art configurations.

[0111] It is understood that the arm embodiments disclosed herein can be utilized in any type of medical device, including those devices in which a compact or smaller size is desirable, such as devices for procedures to be performed within a patient. For example, the arm embodiments could be incorporated into various robotic medical devices, including in vivo robotic devices such as robotic devices positionable on or near an interior cavity wall of a patient, mobile robotic devices, or robotic visualization and control systems. An “in vivo device” as used herein is any device that can be positioned, operated, or controlled at least in part by a user while being positioned within a body cavity of a patient, including any device that is positioned substantially against or adjacent to a wall of a body cavity of a patient, and further including any such device that is internally actuated (having no external source of motive force). As used herein, the terms “robot,” and “robotic device” shall refer to any device that can perform a task either in response to a command or automatically. Further, the arm embodiments could be incorporated into various robotic medical device systems that are actuated externally, such as those available from Apollo Endosurgery, Inc., Hansen Medical, Inc., Intuitive Surgical, Inc., and other similar systems.

[0112] According to one embodiment as depicted in FIG. 16, one arm embodiment is incorporated into an in vivo medical device 402 as shown. The device 402 has two robotic arms 404, 406 that can be configured according to any embodiment described herein.

[0113] FIGS. 17a and 17b depict a device arm 410, according to one embodiment. The arm 410 has two gears: (1) a distal gear 412 that provides for extension and retraction of the arm 410, and (2) a proximal gear 414 that provides for rotation of the arm 410.

[0114] The distal gear 412 has gear teeth 416 on its outer surface and further is threaded on its inner surface (not shown). The gear teeth 416 mate or couple with gear teeth 418 on a drive gear 420, which is coupled to an actuator (not shown). In one embodiment, the actuator is a Permanent Magnet Direct Current (“PMDC”) motor. Thus, the distal gear 412 is driven by the actuator.

[0115] The threading on the inner surface of the distal gear 412 mates or couples with the threading 413 on the outer surface of the arm 410 such that when the distal gear 412 is driven by the actuator, the gear 412 rotates and the coupling of the threads on the inner surface of the gear 412 with the threads 413 on the arm 410 causes the arm 410 to extend or retract depending on which direction the gear 412 turns.

[0116] The proximal gear 414 has gear teeth 422 on its outer surface that mate or couple with gear teeth 424 on a drive gear 426, which is coupled to an actuator (not shown). The gear 414 also has a pin 428 disposed within the gear 414 that extends through the gear 414 and further through a slot

430 in the arm 410. Thus, when the proximal gear 414 turns, the pin 428 causes the arm 410 to turn as well.

[0117] The distal 412 and proximal 414 gears interface or interact at the bearing surfaces. More specifically, the distal gear 412 has a bearing surface 432 (best shown in FIG. 17b) having two bushings 434, 436 disposed or positioned on the outer surface of the bearing surface 432. Similarly, the proximal gear 414 has a bearing surface 438 having two bushings 440, 442. The bearing surface 432 has a smaller diameter than, and is disposed within, the bearing surface 438 such that the inner surface of bearing surface 438 is in contact with the two bushings 434, 436. As such, the bearing surfaces 432, 438 contact each other and rotate in relation to one another at the two bushings 434, 436. Further, the two bushings 440, 442 disposed on the outer surface of the bearing surface 438 typically contact the external gear housing or other type of housing (not shown).

[0118] In an alternative embodiment, gear pairs 418, 412 and 424, 422 as depicted in FIGS. 17A and 17B are replaced with round wheel pairs in which each wheel is configured to be in contact with the other wheel in the pair. In such an embodiment, each wheel has a coating or other surface component that provides for sufficient friction when the wheels are in contact to transmit rotational energy between the two wheels. According to one embodiment, the coating is a thin rubber coating. Alternatively, the coating or surface can be any known coating or surface that provide sufficient friction to allow transmission of rotational energy. This friction drive system allows the gearing components to be reduced in size because of the elimination of the gear teeth.

[0119] In a further embodiment, the gears can also be replaced with a series of cables and drums that are used to actuate the arm. In this pulley system embodiment, the actuator that drives the cables can be located in another portion of the robot, while a series of drums are disposed on the arms. The cabling connects the drums with the actuator (such as a motor). This embodiment allows the actuators, drums, and arm components to be configured in a variety of different orientations while still providing sufficient actuation forces and speed to the arm end effectors.

[0120] FIG. 18 depicts another device arm 450, according to an alternative embodiment. The arm 450 has a distal gear 452 and a proximal gear 454.

[0121] The distal gear 452 has gear teeth 456 and is threaded on its inner surface (not shown). The gear teeth 456 mate or couple with gear teeth 458 on a drive gear 460, which is coupled to an actuator (not shown). As with the previous embodiment, the threading on the inner surface of the distal gear 452 mates or couples with the threading (453) on the outer surface of the arm 450 such that when the distal gear 452 is driven by the actuator, the gear 452 rotates and the coupling of the threads on the inner surface of the gear 452 with the threads 453 on the arm 450 causes the arm 450 to extend or retract depending on which direction the gear 452 turns.

[0122] Similarly, the proximal gear 454 has gear teeth 462 on its outer surface that mate or couple with gear teeth 464 on a drive gear 466, which is coupled to an actuator (not shown). The gear 454 also has a pin 468 disposed within the gear 454 that extends through the gear 454 and further through a slot 470 in the arm 450. Thus, when the proximal gear 454 turns, the pin 468 causes the arm 450 to turn as well.

[0123] The bearing surfaces in this embodiment depicted in FIG. 18 differ from those in the prior embodiment. That is, the distal gear 452 has a bearing surface 472 that is adjacent to

and in contact with a bearing surface **474** of the proximal gear **454**. Thus, the gears **452**, **454** rotate in relation to each other at the bearing surfaces **472**, **474**. In addition, the two bearing surfaces **472**, **474** typically contact or are disposed within an external gear housing **476**.

[**0124**] Although the present invention has been described with reference to preferred embodiments, persons skilled in the art will recognize that changes may be made in form and detail without departing from the spirit and scope of the invention.

[**0125**] One end effector or operational component that can be used with any of the procedural devices disclosed herein is a winch system. Generally, the devices or systems discussed herein are configured to be inserted into or positioned in a patient's body, such as a body cavity, for example. Alternatively, the winch systems and devices disclosed herein can be used with any medical or procedural device.

[**0126**] One embodiment of a medical device having a winch component is set forth in FIGS. **19A** and **19B**. The medical device **510** is an in vivo robotic device **510** that can be positioned within a cavity of a patient, and further has a magnetic handle **512** that can be disposed at a location external to the patient. In this embodiment, the handle **512** operates to hold the device **510** inside the abdominal cavity against the peritoneum (abdominal wall) via magnetic forces. Alternatively, any known method or component for holding the device **510** against the wall could be used. For example, in one embodiment, the robot **510** could be held against the wall using hooks or clamps. In a further alternative, the winch systems disclosed herein can be used with any known medical devices, including—but not limited to—in vivo devices with arms or wheels.

[**0127**] In the implementation depicted in FIGS. **19A** and **19B**, the device **510** has a winch component **524** and a motor **530** to actuate the winch **524**. In this embodiment, the winch component **524** includes a drum **526** and a winch tether **528**. The drum **526** operates to wind and unwind the winch tether **528**.

[**0128**] In accordance with the depicted embodiment, the device **510** has magnets **520** that are magnetically coupleable with magnets **532** on the handle **512** such that the device **510** is urged toward and held against the body cavity wall. The device **510**, the handle **512**, and the magnets **520**, **532** can be configured and/or operated in the same fashion as described in U.S. application Ser. No. 11/766,720, filed on Jun. 21, 2007 and entitled "Magnetically Coupleable Robotic Devices and Related Methods," which is incorporated by reference above. In one embodiment, it is understood that the magnets **520** are configured not only to ensure that the imaging component **516** is positioned to capture a view of the body cavity or the target area of interest for securing the winch **524**, but are also configured to provide a magnetic coupling that is strong enough to maintain the device **510** in a stable and substantially fixed position such that the winch component **524** can be operated as desired and as described herein.

[**0129**] According to the exemplary embodiment in FIGS. **19A** and **19B**, the actuation component **530** is a motor **530** that provides force for rotating the drum **526**. In this embodiment, the motor **530** is a 6 mm brushed motor that turns a planetary gear, which revolves around a stationary sun gear, thereby causing the drum **526** to rotate inside the body **514**. Alternatively, a clutch (not shown) can be used to provide both (1) panning motion of a camera **516** along the axis of the body **514**, and (2) winch actuation using a single motor. In a

further alternative, an exterior drive train can be used to actuate the winch **524**. It is understood that any known actuation component that can be used with medical devices can be used with the winch components or systems disclosed herein.

[**0130**] In one embodiment, the winch tether **528** is made from suture material. In another embodiment, it is metallic cabling. Alternatively, any known material for use in a medical winch tether can be used.

[**0131**] In one embodiment, various operational components or end effectors can be attached to the end of the winch tether. In one embodiment, the end of the winch tether **528** is attached to a hook **536**, as depicted in the embodiment of FIGS. **19A** and **19B**. Such a hook is depicted in use in FIG. **20**. Alternatively, the end effector (also referred to as an "operational component") of the tether can be a clamp or loop. In a further alternative, any known operational component, including any known component for attaching to tissue, can be used.

[**0132**] In another embodiment, the operational component can be a magnet **540** that can be held against the wall with a second handle **542** as depicted in FIG. **21**. In a further embodiment, the device could have two winch components **550** with magnet operational components **552** that attach to two points in vivo as depicted in FIG. **22**. Such a device could have two separate drums and motors, or alternatively, a single motor and drum.

[**0133**] The winch components and systems can be used to accomplish a variety of procedural tasks. In one embodiment, a device having a winch component could be used to retract an organ, such as the gallbladder, as depicted for example in FIG. **20**. In another embodiment, a device having a winch component and a magnet operational component could be used as a sling to retract or move a very large organ such as the liver as depicted in FIG. **21**. In yet another embodiment, the device is used as a "gantry crane" with two winch tethers attached to the abdominal wall, as depicted in FIG. **22**, or to other organs. In this embodiment, the device is guided along the winch tethers to change the camera or illumination location. In another embodiment, the device could be guided along the winch tether, with a third winch hook (or grasper) below the device as shown in FIG. **22**. This would allow the robot to reposition itself along the line of the first two tethers while the third winch could be used to grasp a tissue of interest for retraction or other manipulation. In yet another embodiment, the guide tethers are not suspended but lying on the organs.

[**0134**] In yet another alternative embodiment, the winch component can be any known configuration or be made up of any known components for use in a winch. Further, while certain device embodiments are described for exemplary purposes herein, it is understood that a winch component can be incorporated into any known robotic device for use inside a patient. For example, such a component can be incorporated into any of the devices disclosed in the applications that are incorporated herein elsewhere in this application.

[**0135**] Various additional embodiments disclosed herein relate to procedural devices with modular mechanical and electrical packages that can be used together in various combinations to provide capabilities such as obtaining multiple tissue samples, monitoring physiological parameters, and wireless command, control and data telemetry. This modular technology provides a flexible device into which one or more of various different components or systems can be integrated.

[**0136**] Current known minimally-invasive surgical technologies require two to three ports to accommodate the lap-

aroscopic tools to explore the abdominal cavity and biopsy tissue of interest. The various embodiments of the devices and modular components disclosed herein require only one port for any medical procedure, thereby reducing patient trauma (1 incision rather than 2 or 3).

[0137] FIG. 23A depicts one exemplary implementation of a modular device having a payload area 566. The payload area 566 is configured to receive any one of several modular components, including such components as the sensor, controller, and biopsy components discussed herein. It is understood that in addition to the specific modular components disclosed herein, the payload areas of the various embodiments could receive any known component to be added to a medical procedural device.

[0138] The modular technology disclosed herein can be incorporated into any type of medical procedural device and is not limited to the robotic devices described in detail herein. Certain device embodiments can be in vivo or robotic devices as defined herein, including devices configured to be positioned within a body cavity of a patient, including certain devices that can be positioned against or substantially adjacent to an interior cavity wall, and related systems. For example, FIG. 23B depicts a different device embodiment having a payload area 566. Thus, while the robotic device embodiments depicted in FIG. 23A is a mobile device having wheels, the various modular components described herein could just as readily be positioned or associated with a payload area in any other kind of robotic device or in vivo device such as the device depicted in FIG. 23B or can further be used in other medical devices and applications that don't relate to robotic devices.

[0139] FIGS. 24A, 24B, and 24C depict a biopsy component 600 according to one embodiment that can be used with any robotic device disclosed herein, including as shown for exemplary purposes in FIG. 23A or FIG. 23B. The mechanism 600 has a biopsy grasper 632 that in this implementation has a piercing or lower jaw component 602 and an upper jaw component 630. The piercing component 602 and jaw component 630 are structured like a pair of jaws, with the piercing component 602 being configured to remain stationary during the sampling process, providing a substantially rigid and stable base against which the upper jaw component 630 can move in a jaw-like fashion in relation to the piercing component 602 such that the jaw component 630 can ultimately make contact with the piercing component 602 and thereby cut the target tissue. Unlike standard laparoscopic biopsy tools that are generally designed to grasp tissue so that the surgeon can then tear the sample free, this grasper is designed to completely sever the sample from the tissue of interest without manual manipulation required by the surgeon or user.

[0140] In this embodiment, the upper jaw component 630 is moved in relation to the piercing component 602 via the collar 604. More specifically, the collar 604 is movably disposed over the piercing component 602 such that it can move back and forth in the direction indicated by arrow A. A proximal portion of the upper jaw component 630 is disposed between the piercing component 602 and the collar 604 and is configured to be positioned such that the distal end of the upper jaw 630 is not in contact with the piercing component 602 and remains in that position when no force is applied to the jaw 630. Thus, when the collar 604 is urged toward the distal end of the piercing component 602, the distal end of the upper jaw component 630 is urged toward the piercing component 602 such that the component 630 is capable of incising or cutting

any tissue disposed between the upper jaw 630 and the piercing component 602 as the upper jaw 630 makes contact with the component 602. And when the collar 604 is urged away from the distal end of the piercing component 602, the distal end of the upper jaw 630 moves away from the piercing component 602 and toward its unrestrained position. Alternatively, it is understood that any known component that can operate in the same fashion as the collar to urge the upper jaw 630 into contact with the piercing component 602 can be incorporated herein.

[0141] The collar 604 is urged back and forth by the motor 624. It is understood that this embodiment is intended to encompass any actuation structure that urges the collar 634 to move back and forth such that the upper jaw component 630 is urged to move in relation to the piercing component 602 and thereby cut target tissue.

[0142] In this particular embodiment as shown in FIG. 24A, the grasper 632 is powered by the motor 624. Motor 624 is coupled to a nut 618 that is driven by the motor 624 along the axis of a lead screw 616 parallel to arrow B. The nut 618 is coupled to a slider 608 via a linkage 610 that is pivotally coupled to the nut at pin 620 and to the slider 618 at pin 628. The nut 618, linkage 610, and slider 608 convert the actuation direction from the direction of arrow B to the direction of arrow A and, according to one embodiment, increase the amount of force applied by the motor 624 to the slider 608.

[0143] The slider 608 is coupled to the collar 604 at two flexible components 606A, 606B, which can be shape-memory components 606A, 606B according to one embodiment. In one example, the flexible components 606A, 606B are comprised of nitinol. Further, the piercing component 602 is coupled to the housing 622 via a flexible component 626. According to one embodiment, the flexible component 626 is a shape-memory component 626 such as nitinol. These flexible components 606A, 606B, and 626 allow for the grasper 632 to be repositioned in relation to the rest of the robotic device to which it is coupled, as will be discussed in further detail below.

[0144] Alternatively, the actuation component and the connection of the actuation component to the collar 634 can be any known structure or component or combination thereof that provides motive force to actuate the grasper 632.

[0145] In one alternative implementation, the piercing component 602 has an internal reservoir (not shown) for storing one or more acquired samples. Unlike most standard laparoscopic biopsy tools that include space for only a single sample, this reservoir can be generally large enough or long enough (or otherwise has sufficient volume) to house multiple samples during a biopsy procedure.

[0146] In use, the biopsy component 600 is positioned next to the target tissue using a method such as the mobile robot wheel, or articulating robot arm. Next, the biopsy component 600 operates in the following manner to obtain a tissue sample. The motor 624 actuates the collar 604 to move toward the distal end of the piercing component 602 and thus actuates the upper jaw 630 to close and contact the piercing component 602. The tissue is cut as the upper jaw 630 is actuated towards the piercing component 602 in a slicing motion. In one embodiment the tissue sample is then stored in the piercing component 602 while additional samples are taken.

[0147] It is understood that the device containing the biopsy component 600 may also have other actuable components such as wheels, arms, etc. FIG. 24A further depicts a motor 614 disposed within a second housing 612 that is configured

to actuate one or more additional actuatable components of the device. In one example, the motor 614 can actuate a wheel (not shown) operably coupled with the device. In another example, this motor 614 actuates an arm (not shown) connected to the device.

[0148] In one aspect, the biopsy component 600 can also be configured to make it easier for the medical device to be inserted through incisions, transported, and stored. FIG. 24B depicts the grasper 632 of the biopsy component 600 positioned at a ninety degree angle in relation to its position in FIG. 24A. This re-positioning of the grasper 632 is accomplished due to the flexibility of the flexible components 606A, 606B, 626 as discussed above. According to one embodiment, this second position of the grasper 632 allows for easier insertion and retraction of the device to which the grasper is coupled. That is, the second position of the grasper 632 allows for the entire device to fit more easily through an incision, a port, or any other opening or device for use in medical procedures. In its operating position as depicted in FIG. 24A, the grasper 632 is positioned perpendicularly to the body of the robotic device to which it is coupled. The overall length of the robot body and grasper 632 is greater than the diameter of most laparoscopic trocars. Thus, to allow the robot/grasper 632 to be inserted through a trocar, the grasper 632 can be moved into a position that is parallel to the length of the robotic device using the support mechanism provided by the three flexible components 606A, 606B, 626 that provide both rigidity and the ability to flex the arm 640 degrees during insertion and retraction through a trocar or through any type of orifice, incision, or tool as necessary. This support mechanism provides the rigidity and forces required during biopsy sampling, with the flexibility required for insertion and retraction before and after the biopsy occurs.

[0149] Alternatively, a variety of alternative support mechanisms using this concept can be envisioned.

[0150] FIG. 25A depicts an alternative embodiment of a biopsy component 640 that can be used with any robotic device disclosed herein. The component 640 has actuation components similar to those in the embodiment depicted in FIGS. 24A, 24B, and 24C, including a nut 646 driven along the axis of a lead screw 648 in the direction indicated by arrow B by a motor 644. The nut 646 is attached to a slider 656 via a linkage 650 that is coupled to the nut 646 at pin 652 and to the slider 656 at pin 650.

[0151] In this embodiment, the slider 656 performs generally the same function as the collar described in FIG. 24. That is, the slider 656 can move in the direction indicated by arrow A in relation to the piercing component 658. Thus, similarly to the collar as described above, as the slider 656 moves over the upper jaw 664, the upper jaw 664 is closed relative to the lower piercing jaw 658.

[0152] FIG. 26 depicts an alternative embodiment of the biopsy component 660 that can be used with any robotic device disclosed herein. The component 660 has actuation components similar to those in the embodiment depicted in FIGS. 24A, 24B, and 24C. In this embodiment the collar 662 is urged in the direction A. As the collar 662 moves forward it pushes the top jaw 664 downwards toward the bottom jaw 666 in direction B. The collar is held in place by the housing 672 in the same manner as described for FIG. 24.

[0153] Unlike other laparoscopic biopsy forceps in which both jaws are hinged about a pivot point, only one jaw, the top jaw 664, of the robotic grasper moves during sampling. The lower half of the grasper, bottom jaw 666, remains stationary

and provides a rigid and stable base against which the top jaw 664 can cut. The fixed bottom jaw 666 is constructed from a hypodermic medical stainless steel tube and it forms a reservoir for storing multiple samples.

[0154] In one embodiment the profile of the top jaw 664 is constructed out of a super-elastic shape-memory nickel titanium alloy (Nitinol) ribbon (Memry Corporation) 0.25 mm thick and 3 mm wide. It is profiled such that the grasper is normally open. A wide variety of profiles can be achieved by heat-treating the ribbon for approximately 10 min at 500° C., followed by quenching in water. The Nitinol ribbon is glued to a fixed nylon rod insert that fits inside the bottom jaw 666.

[0155] The blades of the grasper are titanium nitrate coated stainless steel approximately 1.5 mm long. Small plastic inserts are fixed to the top and bottom jaws, and the blades 668 and 670 are glued to these inserts. The round blade 670 fixed to the bottom jaw has a diameter of 3 mm. The top blade 668 has a semi-circular profile with a diameter of 3.8 mm and overlaps the bottom blade when the jaw is closed. The sample is held within the bottom blade as the trailing edges of the top blade help sever the sample from the tissue.

[0156] FIG. 27 depicts an alternative embodiment of the biopsy component 680 that can be used with any robotic device disclosed herein to staple or clamp tissue. The component 680 has actuation components similar to those in the embodiment depicted in FIGS. 24A, 24B, and 24C. In this embodiment the collar 682 is urged in the direction A. As the collar 682 moves forward it pushes the top jaw 684 downwards toward the bottom jaw 686 in direction B. As the top jaw 684 is pressed downwards against the bottom jaw 686, a small surgical staple 688 can be compressed to staple tissue of interest or to clamp an artery or other vessel.

[0157] This stapling arm 680 was designed to hold and close a common laparoscopic surgical staple. In addition to stapling, this end effector can also be used for applications requiring clamping and holding, such as applying pressure to a bleeding blood vessel or manipulating other tissues of interest.

[0158] FIGS. 28A and 28B depict a further embodiment of a biopsy mechanism 690, according to one implementation. These two figures provide a detailed depiction of the opening and closing of grasper jaws 694, 696 according to one embodiment. More specifically, FIG. 28A depicts the mechanism 690 with the grasper jaws 694, 696 in their open configuration. In this configuration, the upper jaw 694 is in a position in which the distal end is not in contact with the distal end of the lower jaw 696.

[0159] FIG. 28B depicts the mechanism 690 with the grasper jaws 694, 696 in their closed configuration. That is, the collar 698 has moved from its retracted position in FIG. 28A to its extended position in FIG. 28B such that it has urged the upper jaw 694 down toward the lower jaw 696 such that the jaws 694, 696 ultimately reach the closed configuration.

[0160] According to one embodiment, an imaging component in any medical device disclosed or incorporated herein having an imaging component can have an adjustable focus mechanism incorporated into or used with the imaging component. One exemplary implementation of such an adjustable focus mechanism 702 is depicted in FIGS. 29A, 29B, 29C, 29D, and 29E. As best shown in FIG. 29E, the mechanism 702 includes a lens subassembly 704 and two magnetic subassemblies 706. The lens subassembly 704 comprises a lens 710, two coils of wire 712 (as best shown in FIGS. 29B, 29D, and 29E), and a lens holding component 714 (as best shown in

FIGS. 29A, 29D, and 29E) to hold the lenses 710 and coils 712 together in one subassembly. As best shown in FIGS. 29D and 29E, each magnetic subassembly 706 includes a small magnet 716 attached to one side of a U-channel 722 made from ferrous metal. The lens subassembly 704 is positioned between the two magnetic subassemblies 706. The coils 712 pass over the U-channels 722 and are positioned in the magnetic field that is generated between the small magnet 716 and the open side of the U-channel 722 where the coil 712 sits. As current is passed through the coiled wire 712 that is positioned in the magnetic field, an electromagnetic force is created that is parallel to the axis of the lens 710 and imager 718. This electromagnetic force is created by the magnetic field being perpendicular to the direction of the current.

[0161] In one embodiment, the small magnets 716 are Neodymium Magnets manufactured by K and J Magnetics of Jamison, Pa., the coils 712 are manufactured by Precision Econowind of North Fort Myers, Fla., and the lens 710 is manufactured by Sunex of Carlsbad, Calif. In this embodiment the magnets have a pull force of 2.17 lbs and a surface field of 2505 Gauss, while the coils are made of 120 turns of 36 AWG coated copper wire with a DSL758 lens. Alternatively, the above components can be any commercially available components.

[0162] According to one implementation, the lens holding component 714 is manufactured of polycarbonate plastic to minimize weight. In the embodiment shown in FIGS. 29D and 29E, the magnets 716 are $\frac{1}{16}$ " \times $\frac{1}{8}$ " \times $\frac{1}{4}$ " and the lens subassembly has a vertical stroke of 1 mm.

[0163] In one embodiment, a restoring force is provided that urges the lens 710 back to its resting position when the current from the coiled wire 712 is removed. This allows for consistent lens subassembly travel and can be used to maintain the lens in an optimum middle range of focus. According to one implementation, the restoring force component 720 as best shown in FIGS. 29A and 29B is a foam component 720. Alternatively, any known component for providing a restoring force can be used.

[0164] In accordance with one embodiment, the adjustable focus mechanism 702 is coupled with an auto focus algorithm to automatically command the mechanism 702 to focus the lens to a commanded depth. In a further embodiment, additional lens subassemblies 704 and magnetic subassemblies 706 can be combined to provide additional points of depth adjustment around the lens. These additional adjustment points allow a higher range of orientation angles of the lens to correct for any imperfections in manufacturing assembly. In this embodiment, the coils can be commanded separately to tilt the lens to correct for manufacturing error.

EXAMPLE

[0165] In this example, different biopsy grasper profiles and lengths were examined, including the effects of those profiles and lengths on the forces required to actuate the biopsy mechanism and further the maximum forces that could actually be applied by the mechanism.

[0166] FIGS. 30A and 30B depict a test jig 730 having a biopsy mechanism according to one embodiment. The test jig 730 as shown included a load cell 748 that was used to measure the tensile force in the nylon supporting rod when the collar 738 was actuated. Further, the biopsy mechanism of the jig 730 had a motor 732, linkage 736, lead nut 734, collar 738, lower jaw 746 and upper jaw 744.

[0167] Various grasper embodiments with a wide range of jaw lengths, opening angles, and jaw profiles were tested for actuation forces. Required actuation forces were determined by using the motor 732 and lead screw linkage 736 to slide the grasper collar 738 over the upper jaw 744 until closed. For each actuation, the required force was recorded starting with the upper jaw 744 completely open and continuing until the upper jaw 744 was closed. Maximum actuation forces were determined by recording the forces applied with the collar 738 held fixed at various positions corresponding to different times during actuation process. Each complete test consisted of 50 actuations of the biopsy grasper. Load cell data were recorded during each actuation at a rate of 20 Hz.

[0168] FIG. 31 depicts the mean results from a required force test for a grasper that is approximately 12 mm long, has an opening angle of 25° and has a cutting tip with a length of 4 mm profiled with a closing angle of approximately 40°. The error bars indicate the standard deviation in the measured forces at intervals of approximately 1.8 seconds. The maximum required actuation force of 2.83 N is at the very start of the motion of the collar due to the need to overcome static friction and to begin flexing the top jaw of the grasper. The force decreases with time as the contact point between the collar and the top jaw moves farther away from the anchor point. The test results indicate that approximately a maximum of 3 N of force is required to close the biopsy grasper.

What is claimed is:

1. A biopsy component, comprising:
 - (a) a substantially fixed jaw component;
 - (b) a mobile jaw component adjacent to the substantially fixed jaw component, wherein the mobile jaw component is predisposed to a position in which a distal end of the mobile jaw component is not in contact with the substantially fixed jaw component; and
 - (c) a sliding component configured to move between a first position and a second position, wherein the sliding component in the second position is in contact with the mobile jaw component such that the sliding component urges the distal end of the mobile jaw component toward the substantially fixed jaw component.
2. The biopsy component of claim 1, further comprising a flexible component operably coupled to the substantially fixed jaw component and a medical device.
3. The biopsy component of claim 2, wherein the flexible component is configured to allow the substantially fixed jaw component to move from a first position to a second position in which the axis of the substantially fixed jaw component is around 90 degrees in relation to the axis of the substantially fixed jaw component in the first position.
4. The biopsy component of claim 3, wherein the second position allows easier insertion of the medical device and biopsy component through a laparoscopic port or an incision.
5. The biopsy component of claim 1, wherein the sliding component is operably coupled to an actuation component.
6. The biopsy component of claim 1, wherein the biopsy component is operably associated with a medical device.
7. The biopsy component of claim 6, wherein the medical device is an in vivo robotic device.
8. An arm device, comprising:
 - (a) an extendable, rotational arm comprising
 - (i) an exterior portion comprising a first coupling component;
 - (ii) a first aperture defined within the arm;

- (b) a first driven component comprising an inner surface comprising a second coupling component configured to be coupled with the first coupling component;
 - (c) a first drive component coupled with the first driven component;
 - (d) a second driven component comprising a second aperture defined within the second driven component;
 - (e) a pin disposed within the first aperture and the second aperture; and
 - (f) a second drive component coupled with the second driven component.
9. The device of claim 8, wherein the first and second coupling components comprise threads.
10. The device of claim 8, wherein the first and second drive components and the first and second driven components comprise gears.
11. The device of claim 8, wherein the first and second drive components and the first and second driven components comprise a pulley system.
12. The device of claim 8, wherein the first and second drive components and the first and second driven components comprise a friction drive system.
13. The device of claim 8, wherein actuation of the first drive component actuates the arm to extend or retract.
14. The device of claim 8, wherein actuation of the second drive component actuates the arm to rotate.
15. A medical device comprising:
- (a) a body
 - (b) a first winch component associated with the body, the first winch component comprising:
 - (i) a first drum; and
 - (ii) a first tether operably coupled to the first drum;
 - (c) an actuation component operably coupled to the first drum.
16. The medical device of claim 15, further comprising an end effector operably coupled to a distal end of the tether.
17. The medical device of claim 16, wherein the end effector is a hook.
18. The medical device of claim 16, wherein the end effector is a magnet.
19. The medical device of claim 15, further comprising a second winch component comprising:
- (a) a second drum; and
 - (b) a second tether operably coupled to the second drum.
20. The medical device of claim 19, further comprising a third winch component comprising:
- (a) a third drum; and
 - (b) a third tether operably coupled to the third drum.
- * * * * *

专利名称(译)	机器人装置中的致动方法和系统		
公开(公告)号	US20090054909A1	公开(公告)日	2009-02-26
申请号	US12/171413	申请日	2008-07-11
申请(专利权)人(译)	板内布拉斯加大学校董		
当前申请(专利权)人(译)	板内布拉斯加大学校董		
[标]发明人	FARRITOR SHANE M RENTSCHLER MARK LEHMAN AMY PLATT STEPHEN R HAWKS JEFF		
发明人	FARRITOR, SHANE M. RENTSCHLER, MARK LEHMAN, AMY PLATT, STEPHEN R. HAWKS, JEFF		
IPC分类号	A61B19/00		
CPC分类号	A61B19/22 A61B19/2203 A61B2017/00278 A61B2017/00539 A61B2017/00544 A61B17/00234 A61B2019/2242 A61B2019/2249 A61B2019/2253 A61B2019/2238 A61B2019/2215 A61B34/30 A61B34 /70 A61B34/71 A61B34/72 A61B34/73 A61B2034/302 A61B2034/306		
优先权	61/025346 2008-02-01 US 60/949390 2007-07-12 US 60/949391 2007-07-12 US 60/990076 2007-11-26 US		
其他公开文献	US8343171		
外部链接	Espacenet USPTO		

摘要(译)

本文公开的实施例涉及各种医疗设备组件，包括可以结合到机器人和/或体内医疗设备中的组件。某些实施例包括各种致动系统实施例，包括流体致动系统，传动系致动系统和无电机致动系统。另外的实施例包括可逆锁定的管，其可以为医疗装置提供进入患者腔的通路，并且还在装置的操作期间提供可逆的刚性或稳定性。进一步的实施例包括用于医疗装置的各种操作部件，包括医疗装置臂机构，其具有轴向和旋转运动，同时保持相对紧凑的结构。医疗设备绞车组件，医疗设备活检/吻合器/夹紧机构，以及医疗设备可调焦点机构。

