



(19) **United States**

(12) **Patent Application Publication**  
**Bonadio et al.**

(10) **Pub. No.: US 2004/0092795 A1**

(43) **Pub. Date: May 13, 2004**

(54) **LAPAROSCOPIC SEALED ACCESS DEVICE**

(30) **Foreign Application Priority Data**

(75) Inventors: **Frank Bonadio**, Wicklow (IE); **Ronan Bernard McManus**, Wicklow (IE); **Derek William Young**, Blackrock (IE); **Alan Reid**, Clontarf (IE); **Alfred Cushieri**, Fife (GB)

Dec. 1, 1998	(IE)	980999
Feb. 15, 1999	(IE)	990107
Feb. 15, 1999	(IE)	990108
Feb. 15, 1999	(IE)	990110
Feb. 15, 1999	(IE)	990112
May 24, 1999	(IE)	990416

Correspondence Address:  
**FINNEGAN, HENDERSON, FARABOW,  
GARRETT & DUNNER  
LLP  
1300 I STREET, NW  
WASHINGTON, DC 20005 (US)**

**Publication Classification**

(51) <b>Int. Cl.<sup>7</sup></b>	<b>A61B 1/32</b>
(52) <b>U.S. Cl.</b>	<b>600/207</b>

(73) Assignee: **Atropos Limited**

(57) **ABSTRACT**

(21) Appl. No.: **10/315,233**

(22) Filed: **Dec. 10, 2002**

**Related U.S. Application Data**

(63) Continuation of application No. 09/804,552, filed on Mar. 13, 2001, now Pat. No. 6,578,577, which is a continuation of application No. PCT/IE99/00123, filed on Dec. 1, 1999.

A hand access device for use in hand assisted laproscopic surgery comprises a substantially tubular inflatable sleeve of pliable gas tight material having a twisted inner sleeve section and an outer sleeve section. The device has an inner O-ring for insertion through a wound opening in the abdominal wall and an outer O-ring for location outside of the wound opening. On insertion of a surgeon's arm the sleeve everts while monitoring a reduced lumen seal to the arm and a seal to the wound openings.

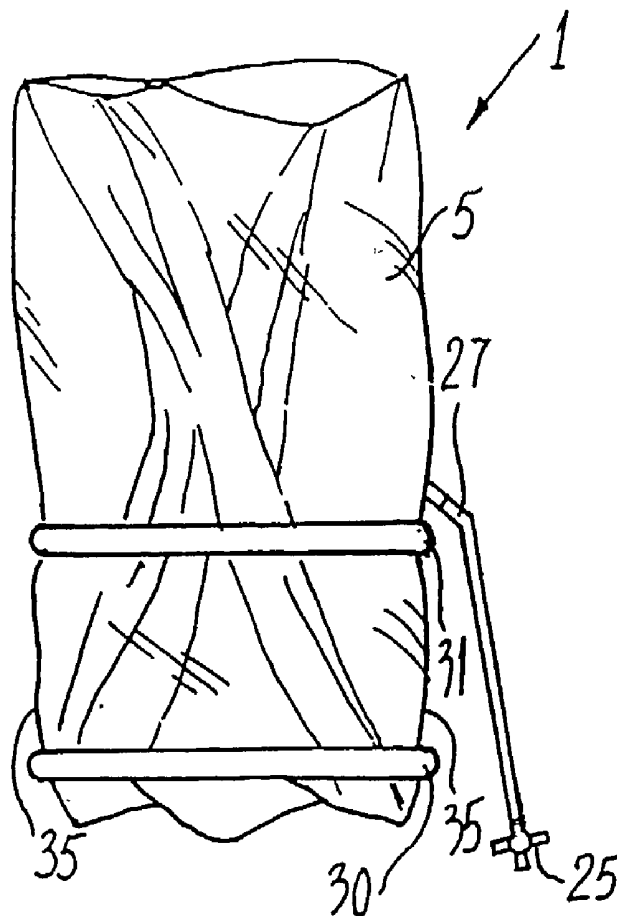

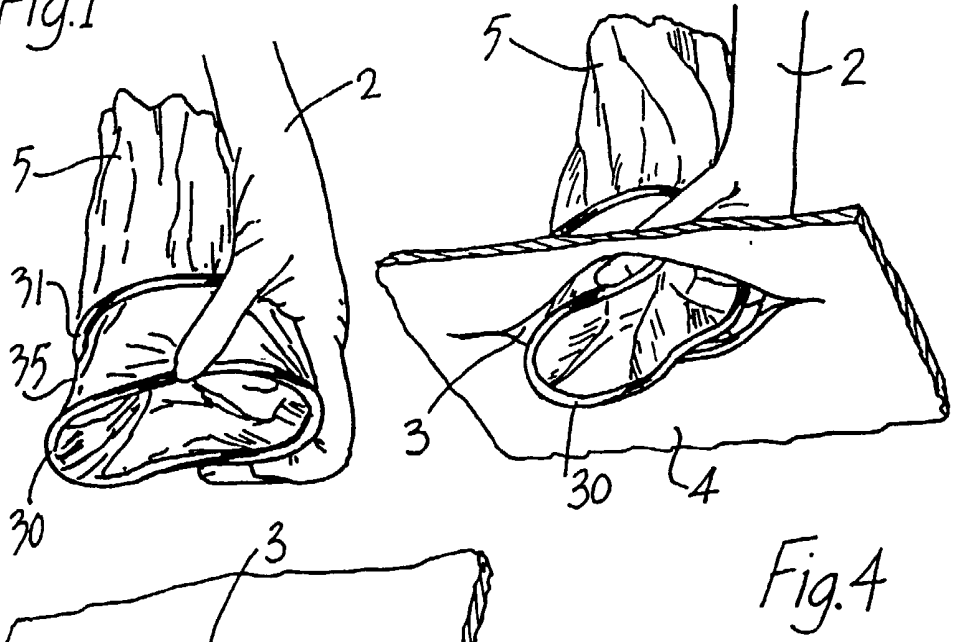
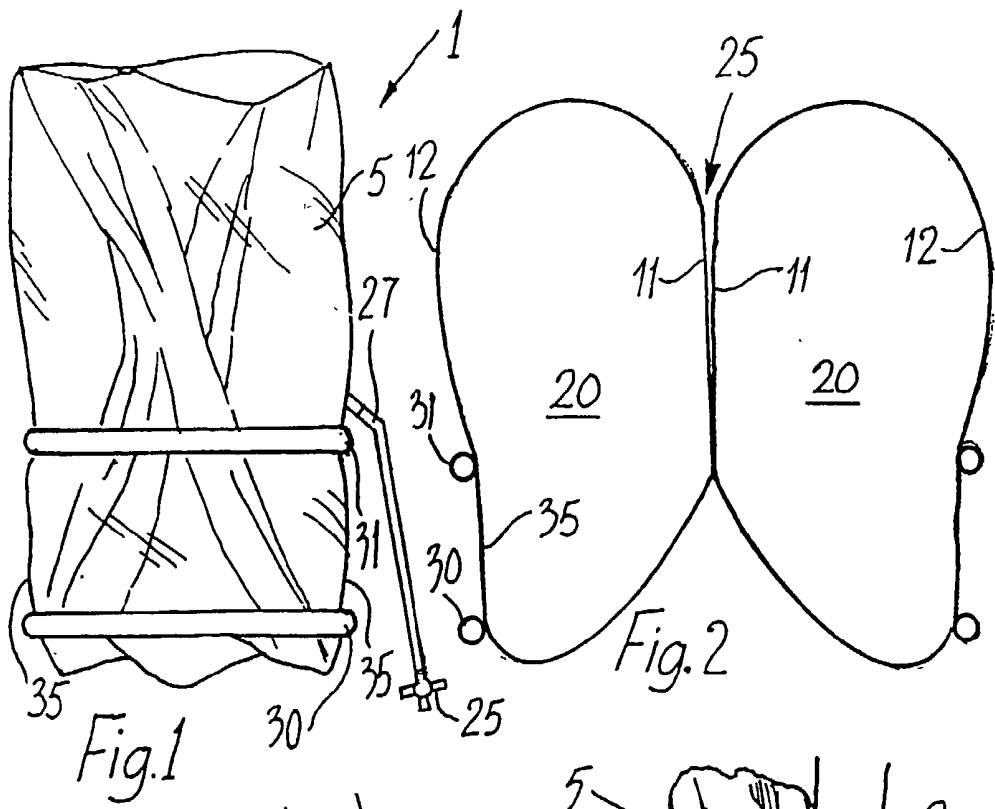
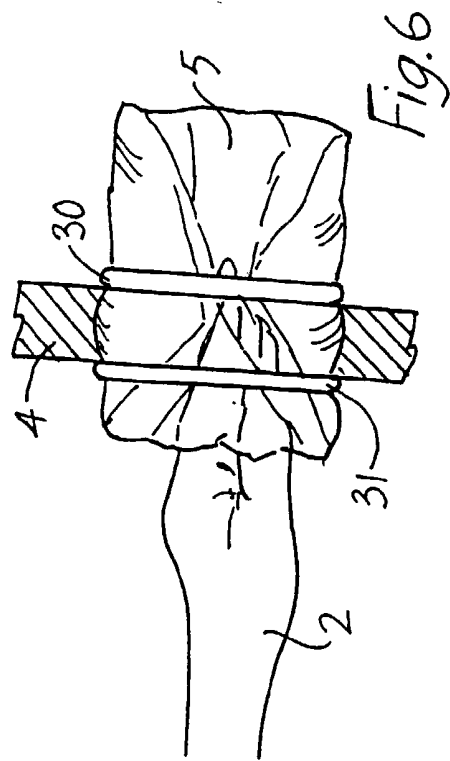
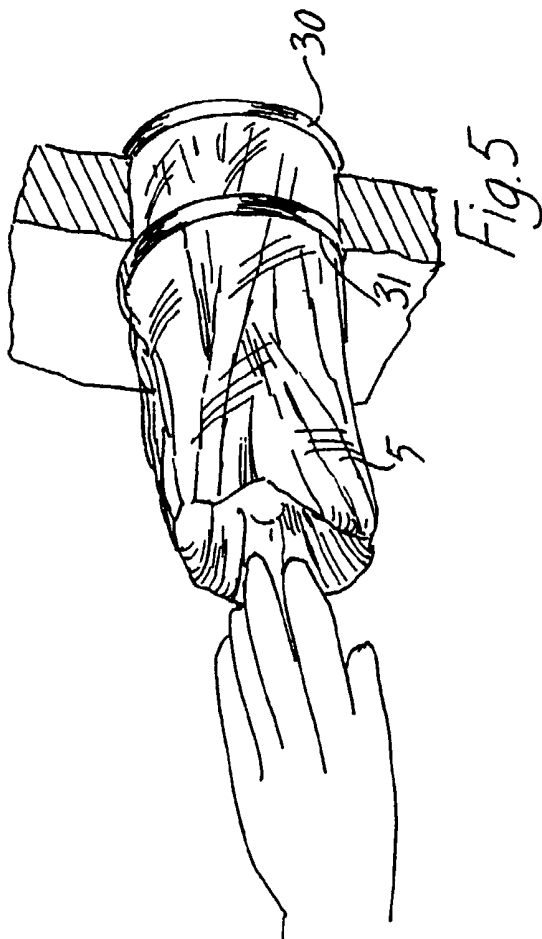
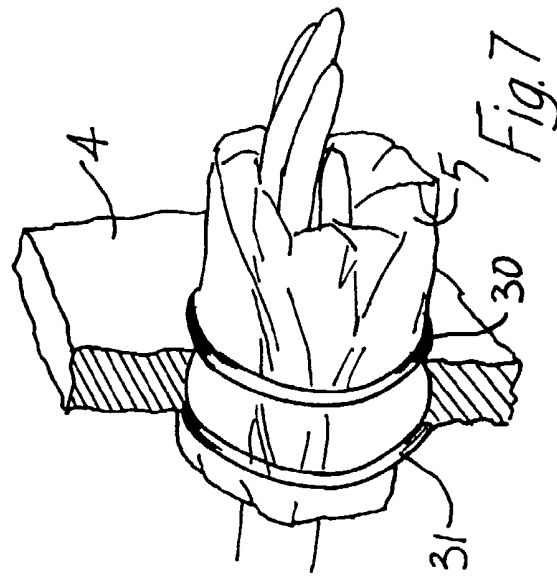
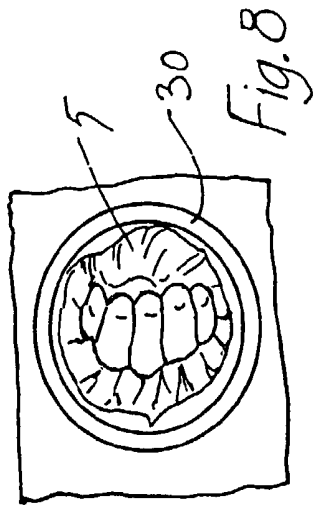
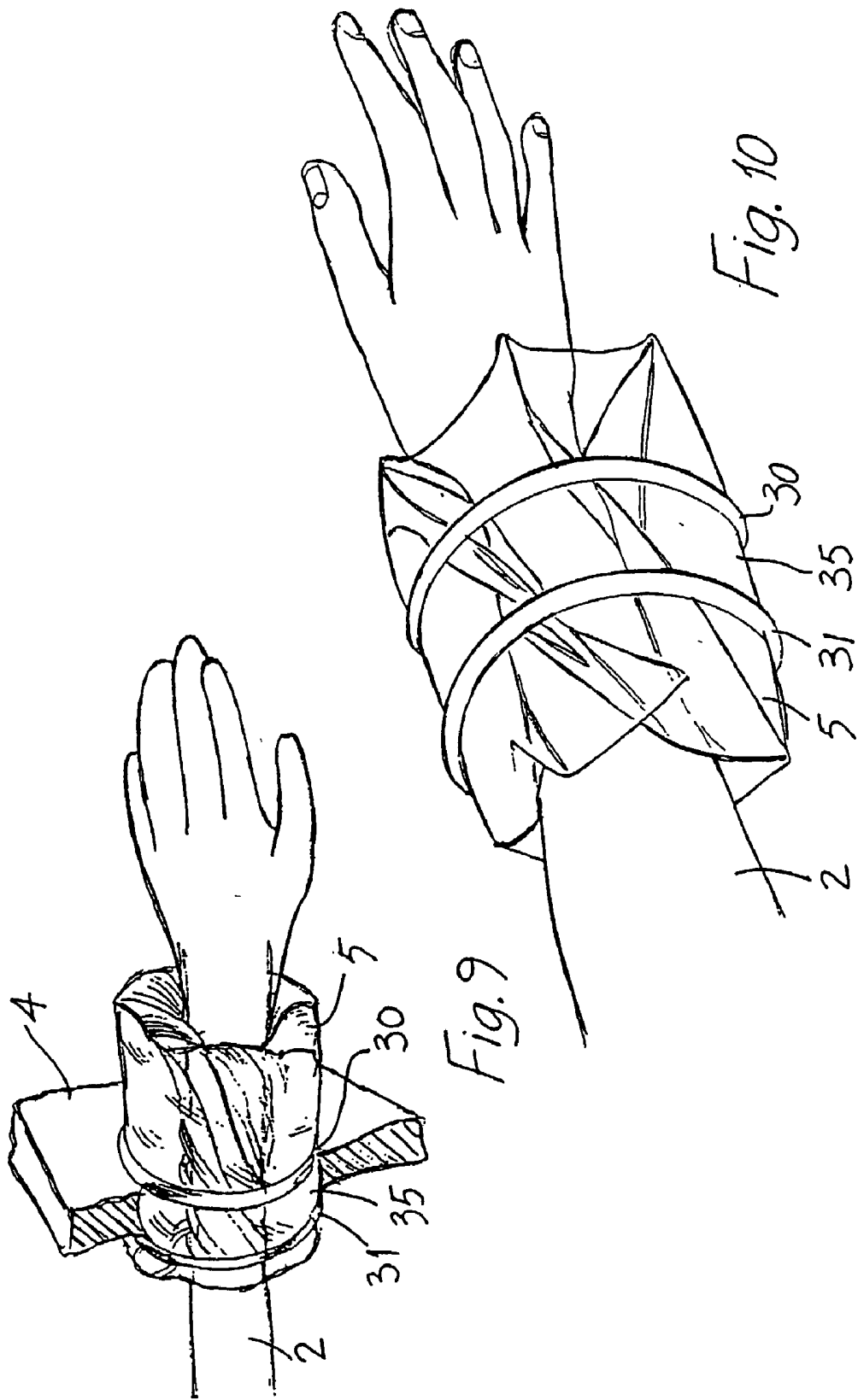
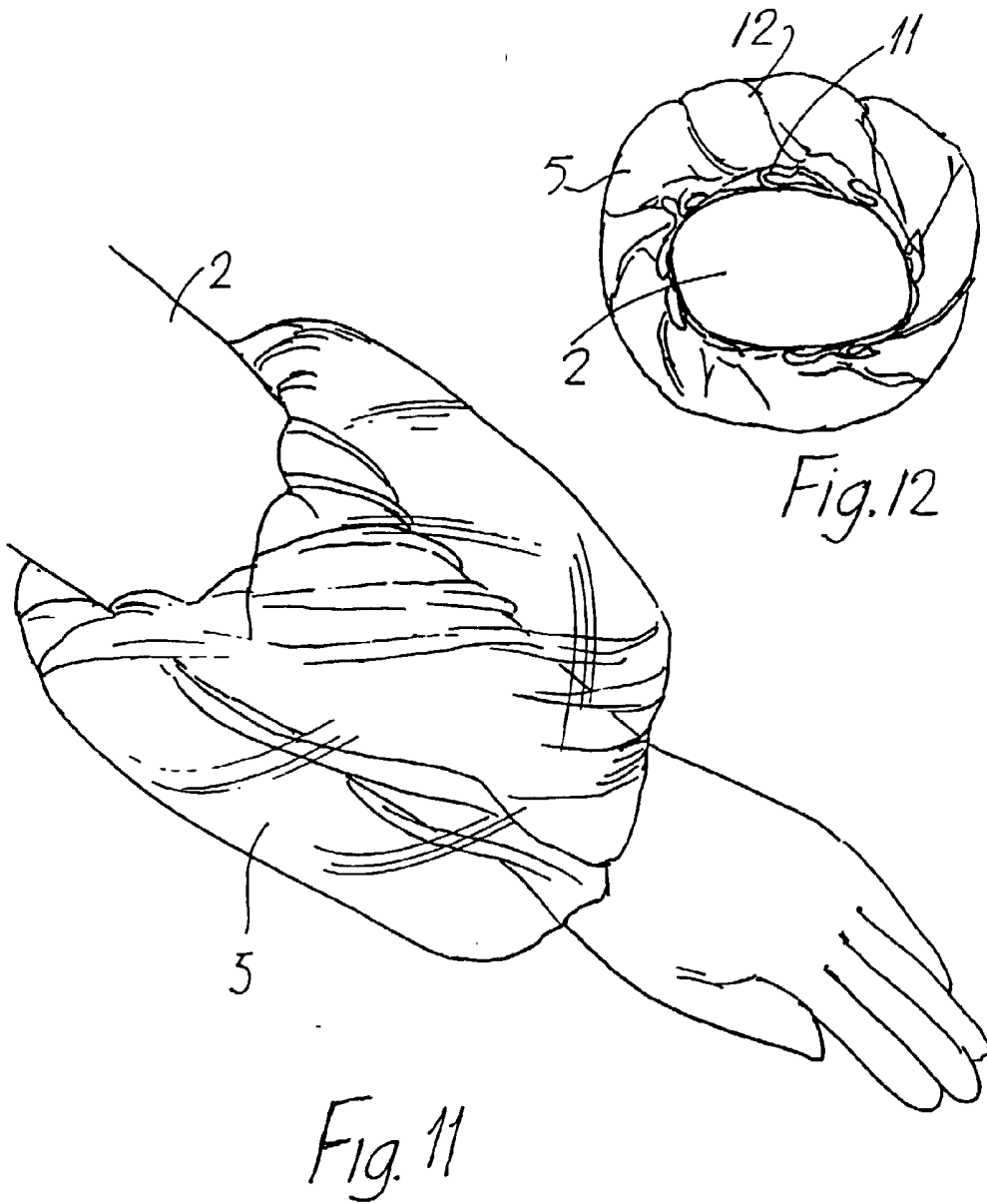

Fig. 3

Fig. 4







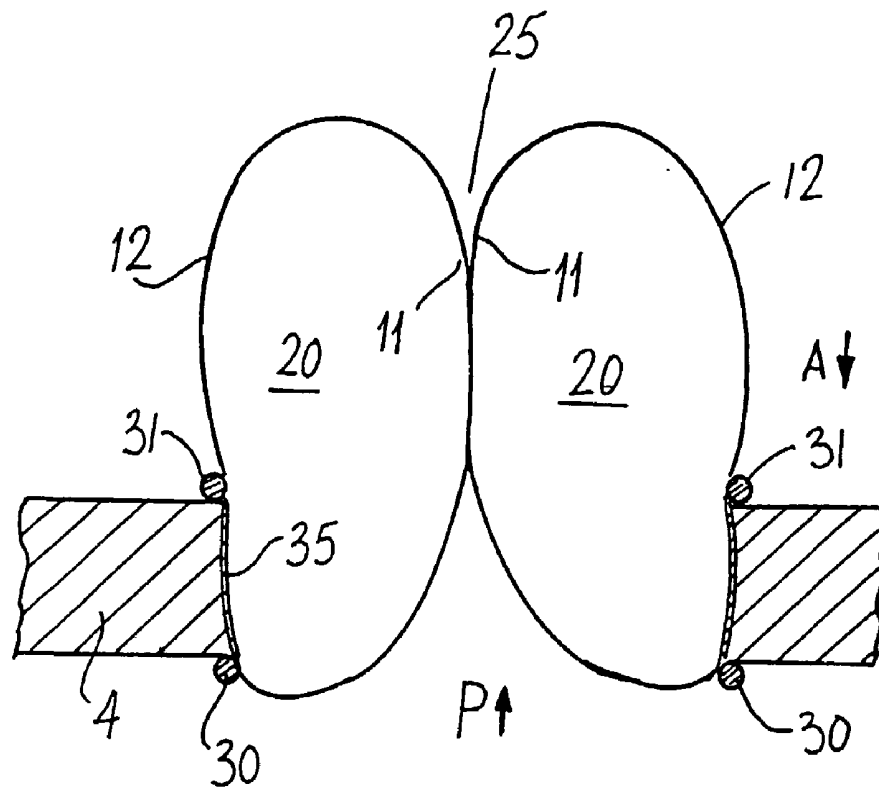

Fig. 13

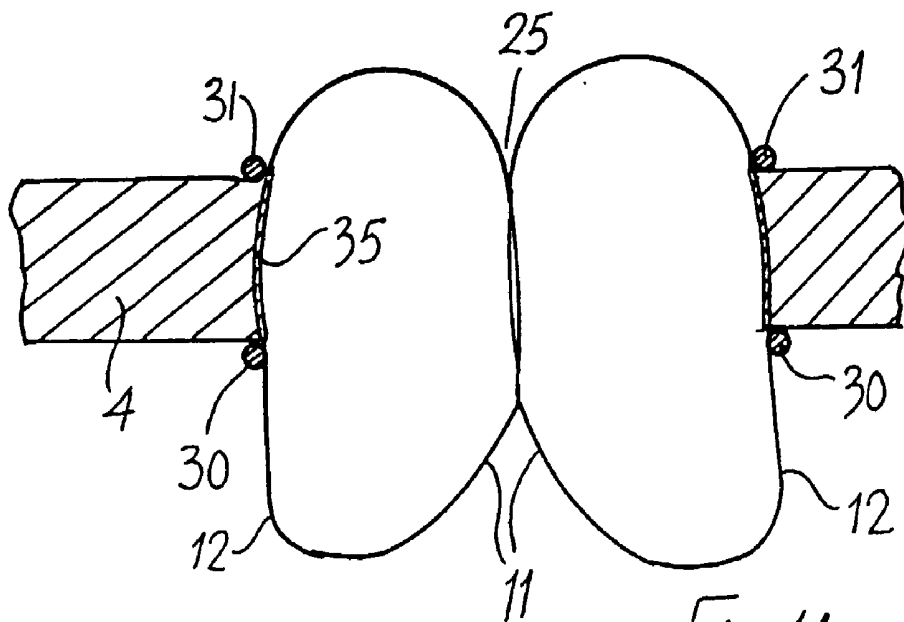

Fig. 14

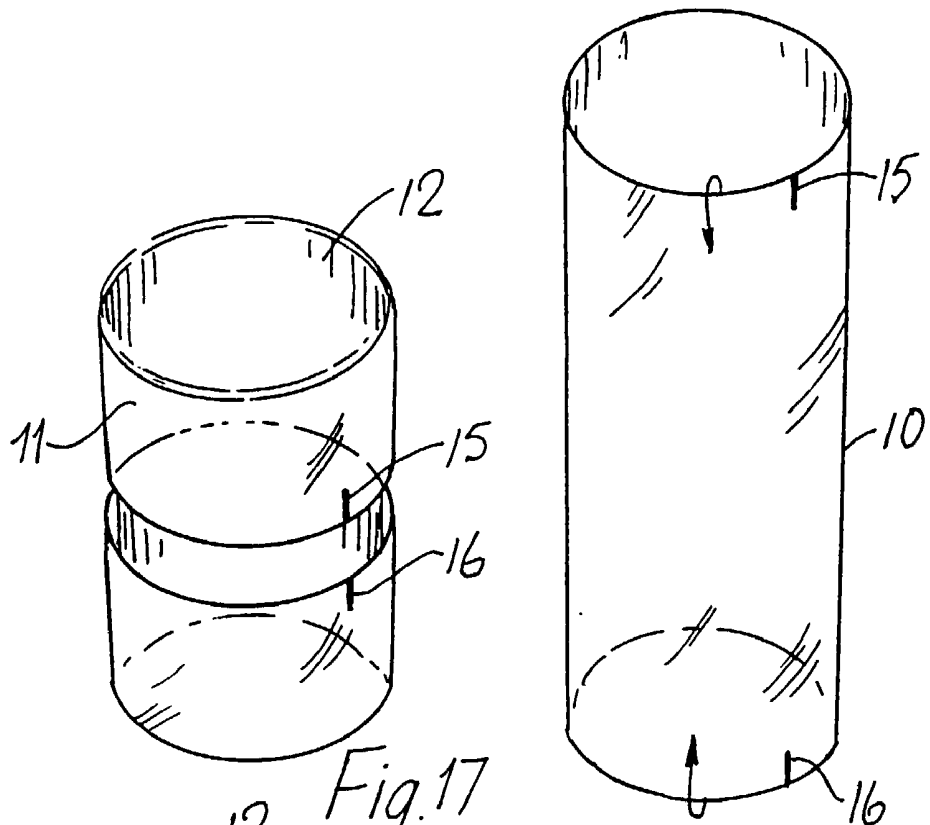

Fig. 17

Fig. 16

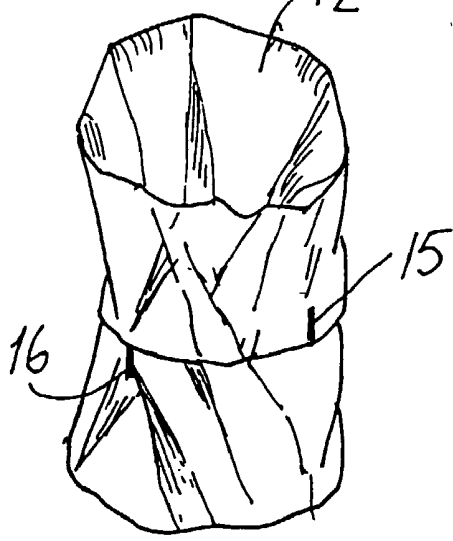

Fig. 18

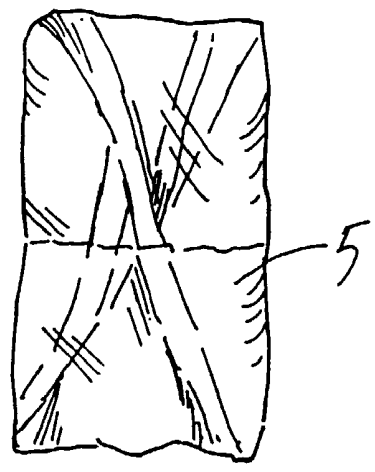

Fig. 19

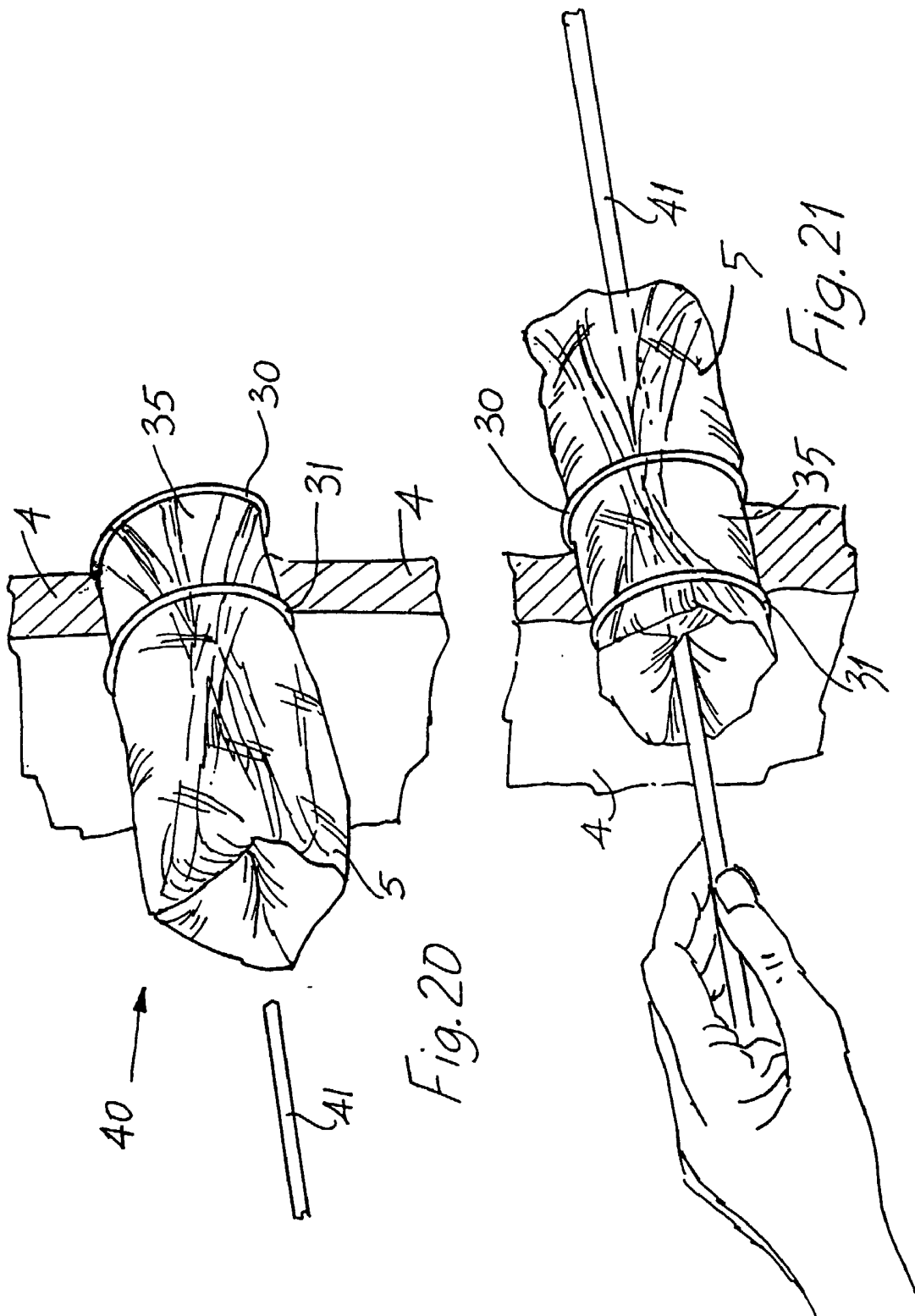
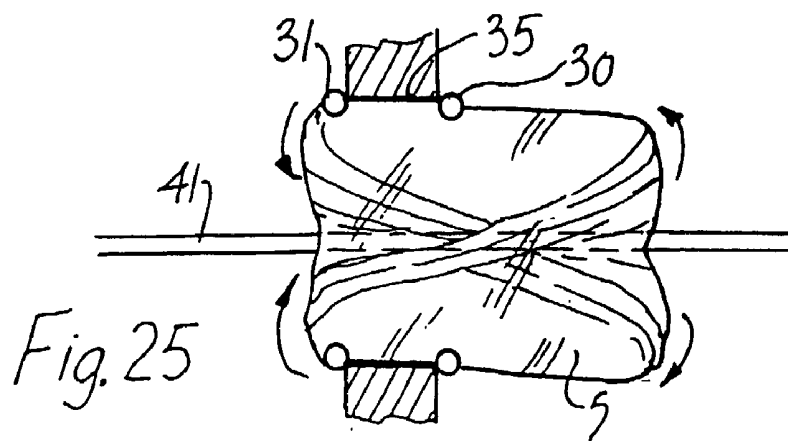
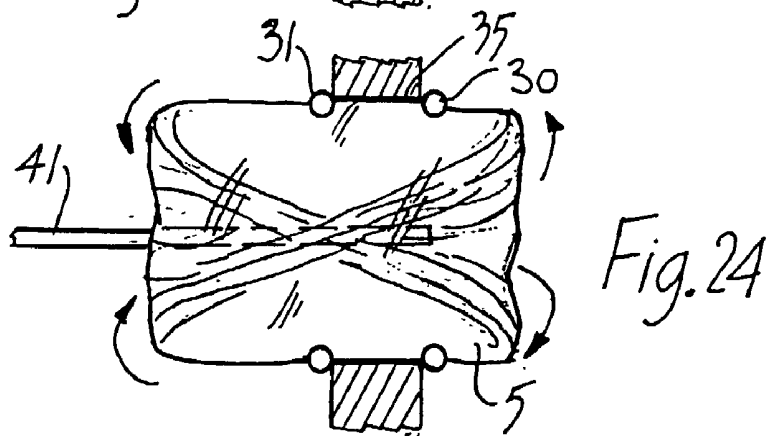
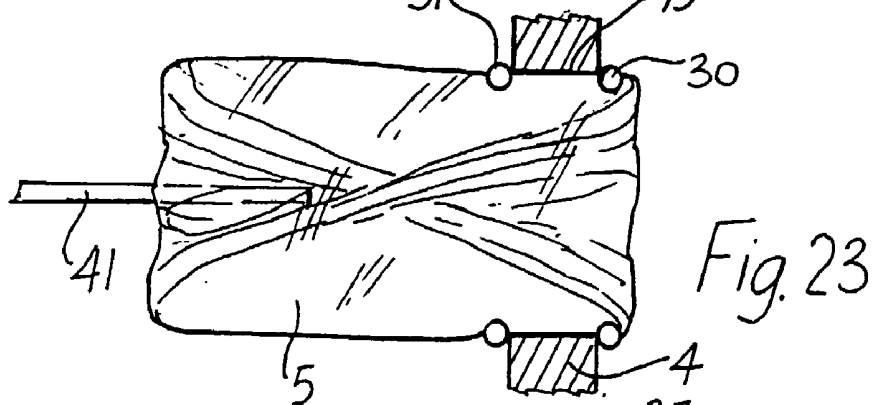
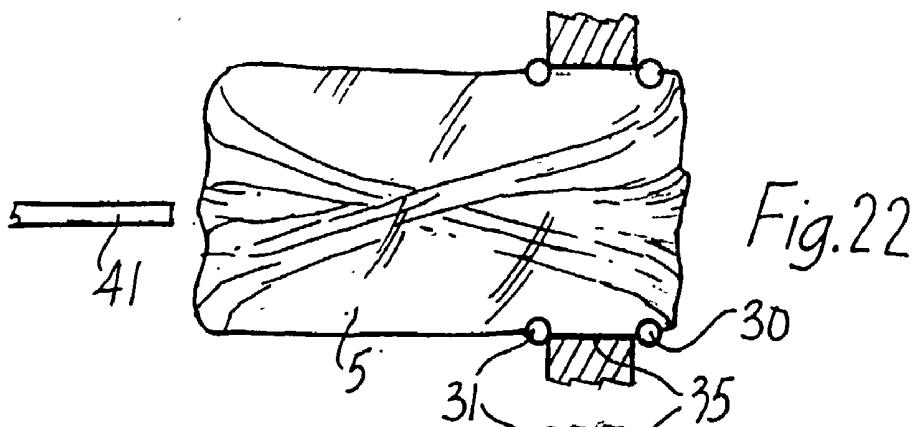

Fig. 20

Fig. 21



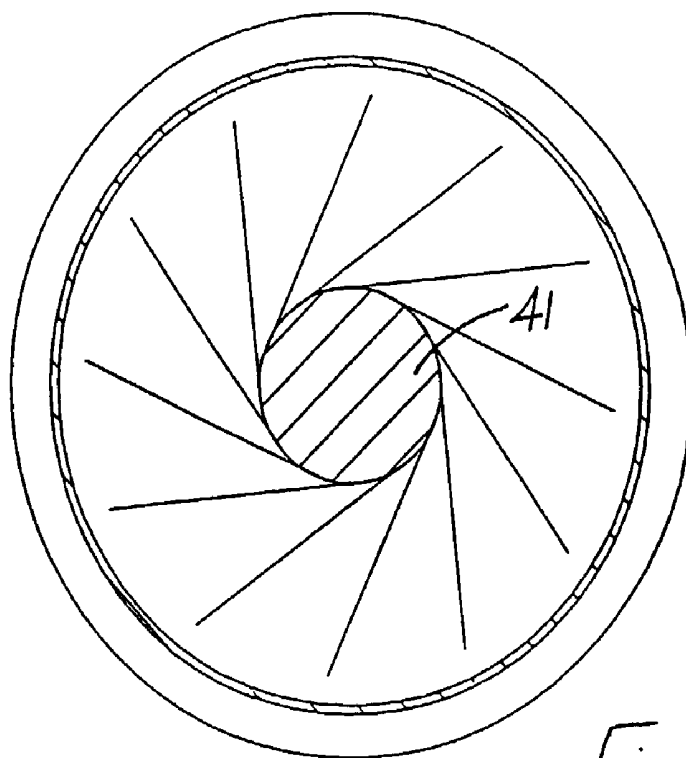

Fig. 26

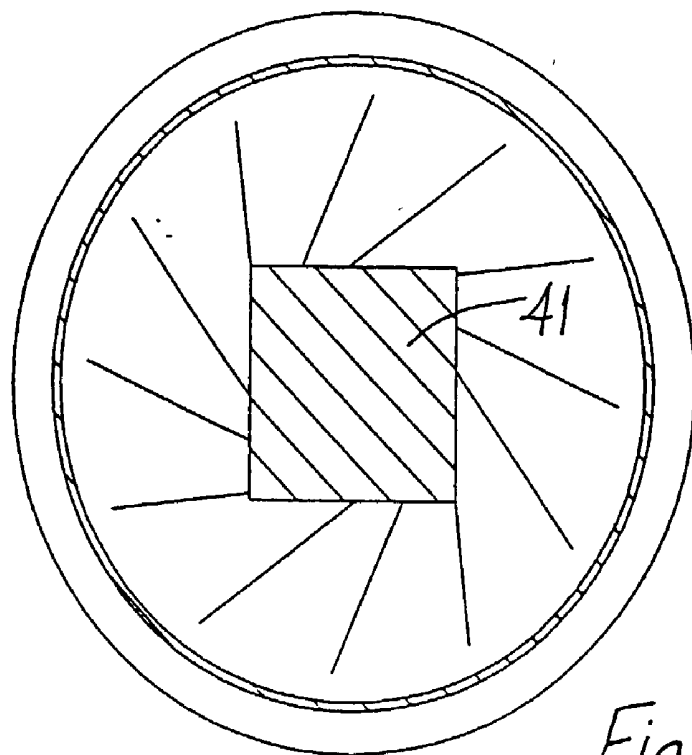

Fig. 27

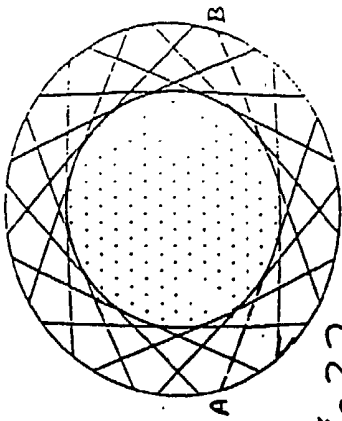

Fig. 28

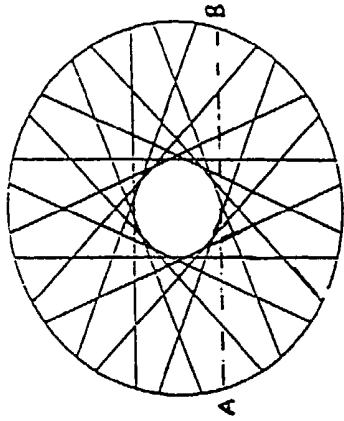

Fig. 30

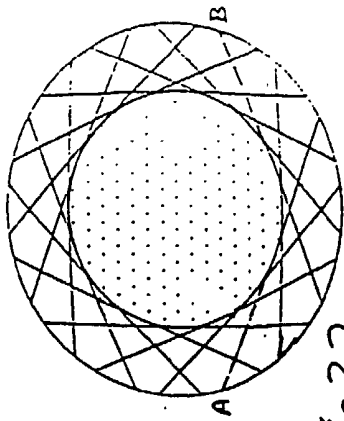

Fig. 32

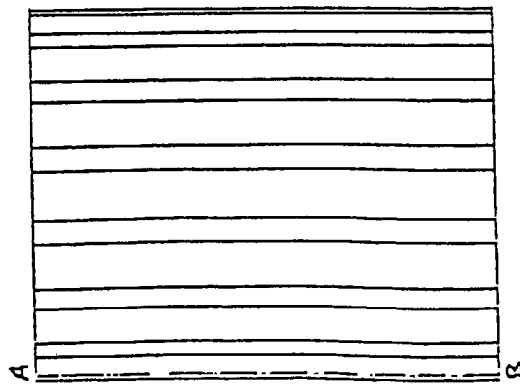

Fig. 29

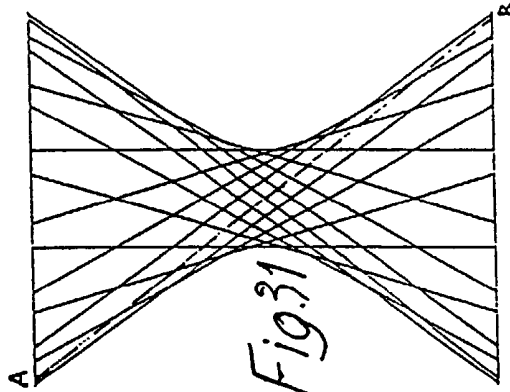

Fig. 31

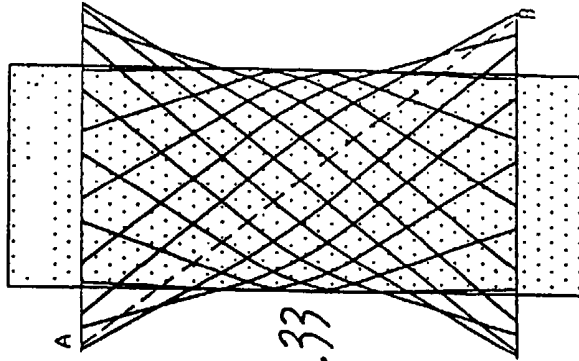

Fig. 33

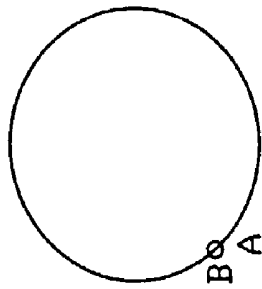

Fig. 34

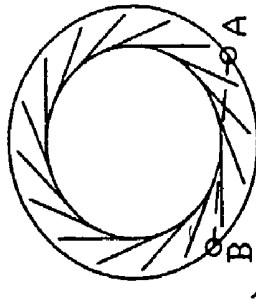

Fig. 36

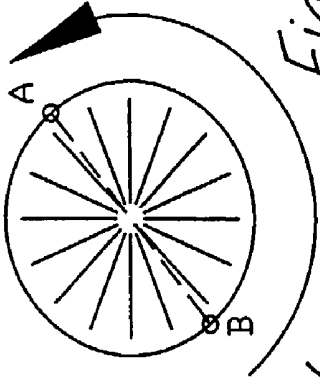

Fig. 38

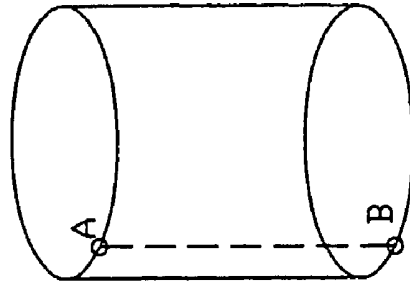

Fig. 35

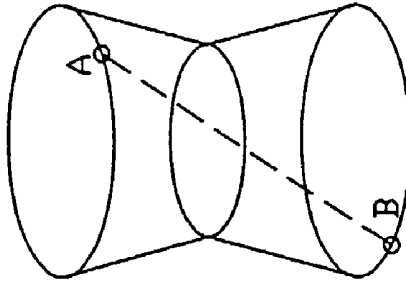

Fig. 37

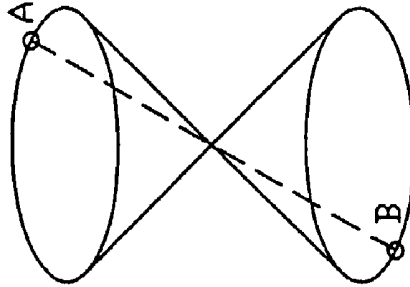

Fig. 39

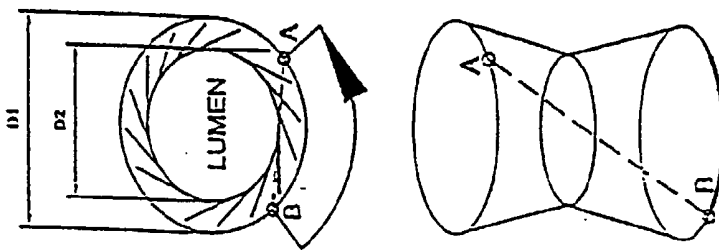
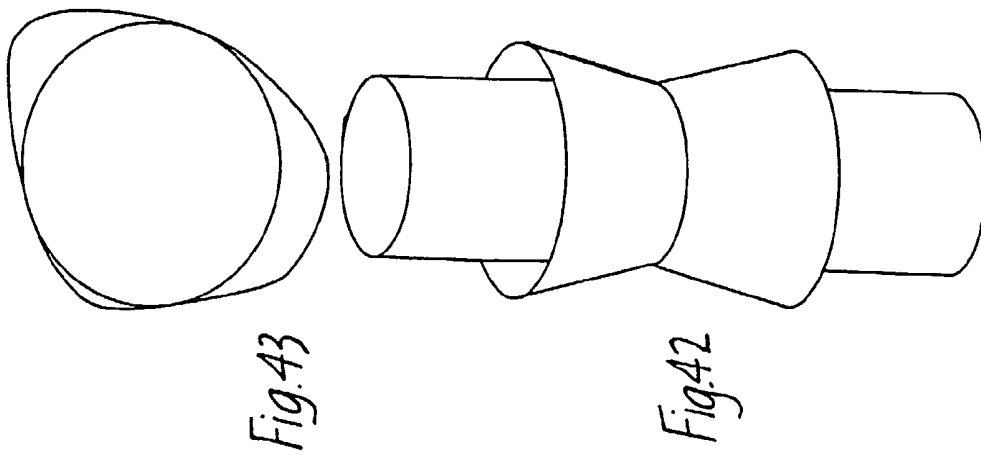

Fig. 40

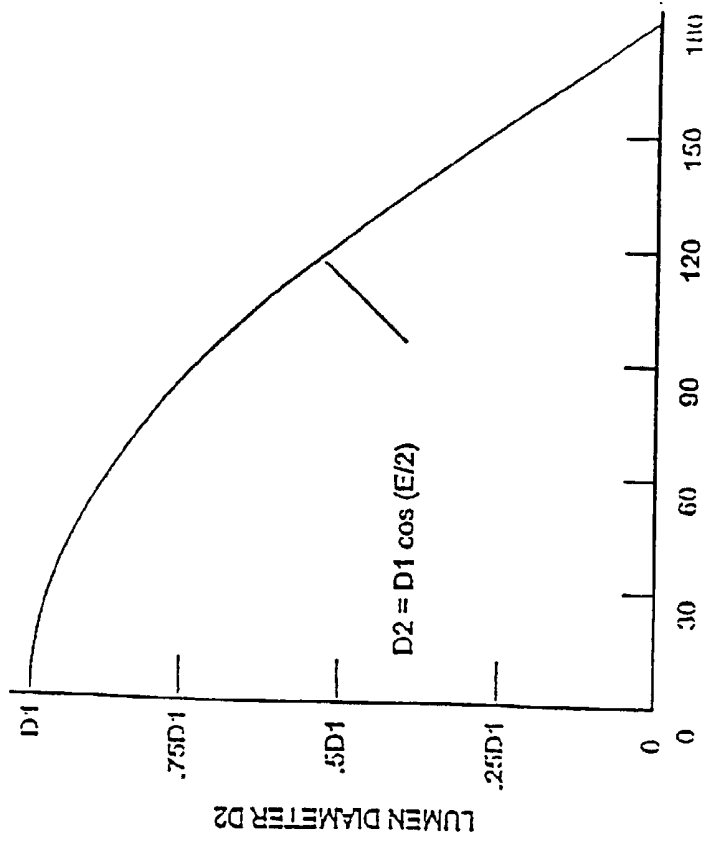
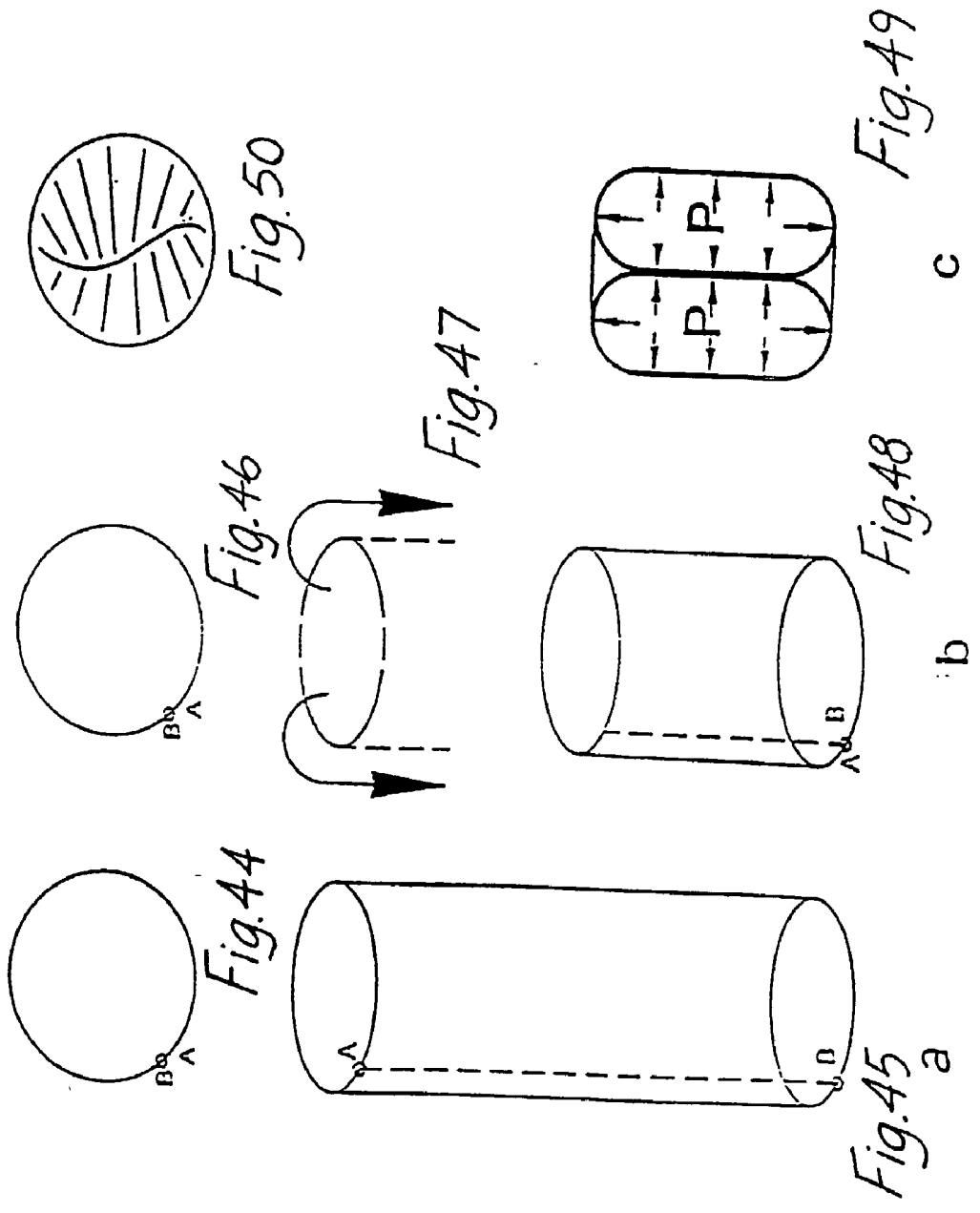

Fig. 41



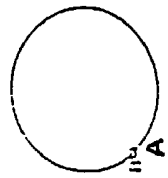

Fig. 51

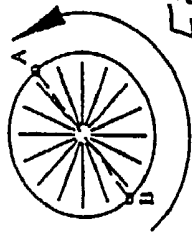

Fig. 53

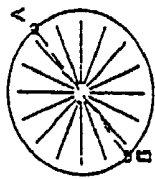

Fig. 55

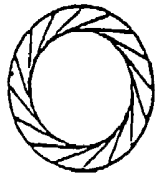

Fig. 58

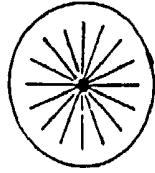

Fig. 60

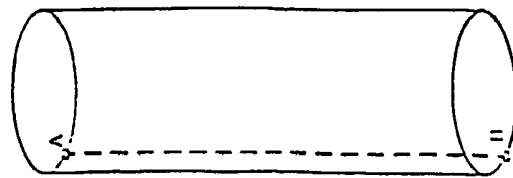

Fig. 52

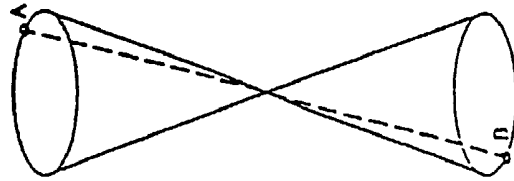

Fig. 54

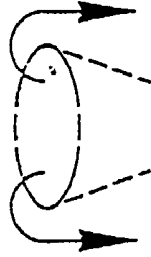

Fig. 57

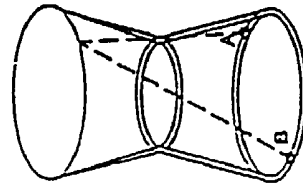

Fig. 59

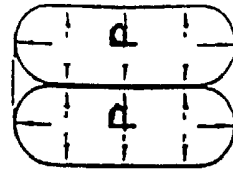
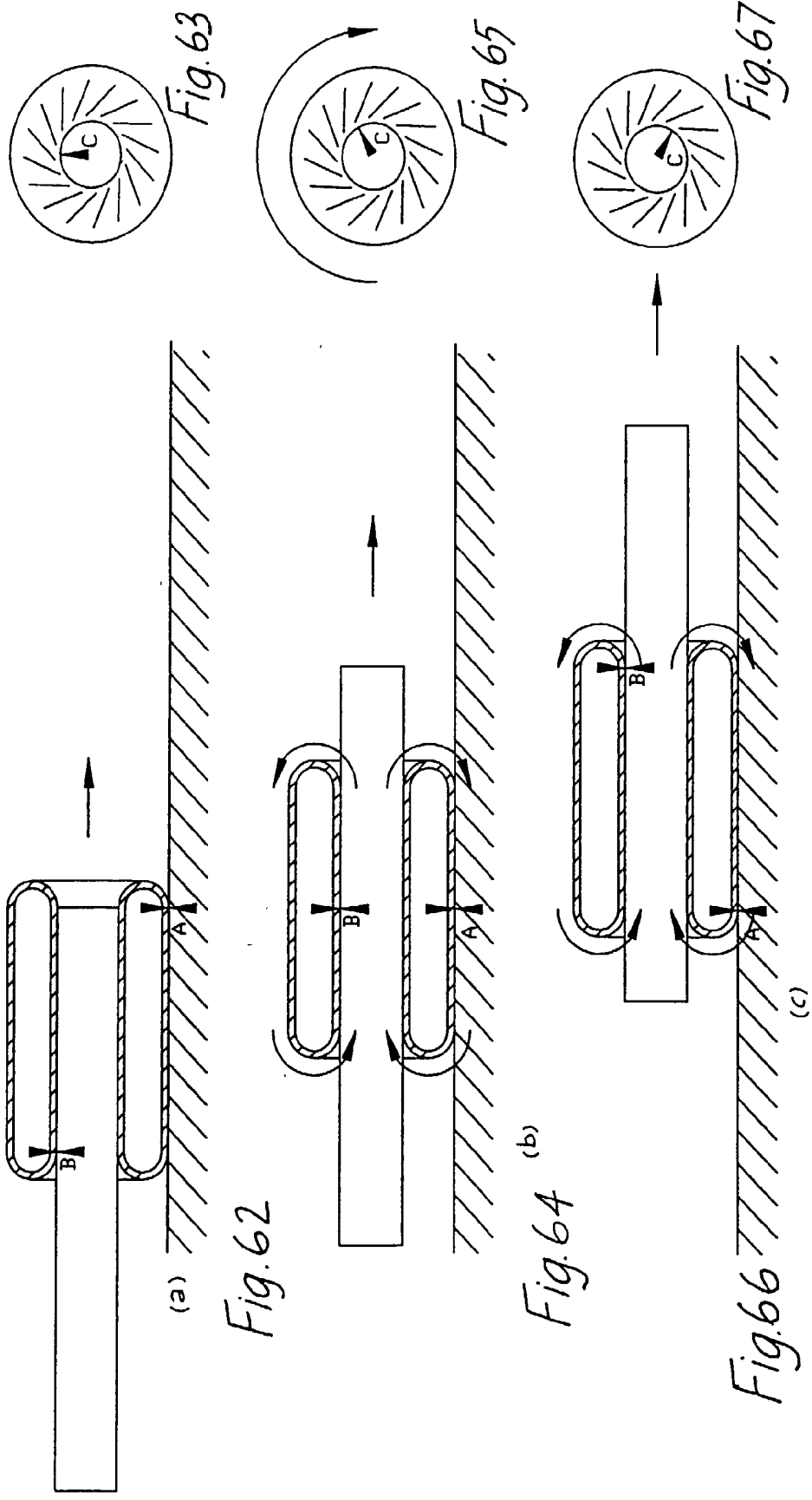
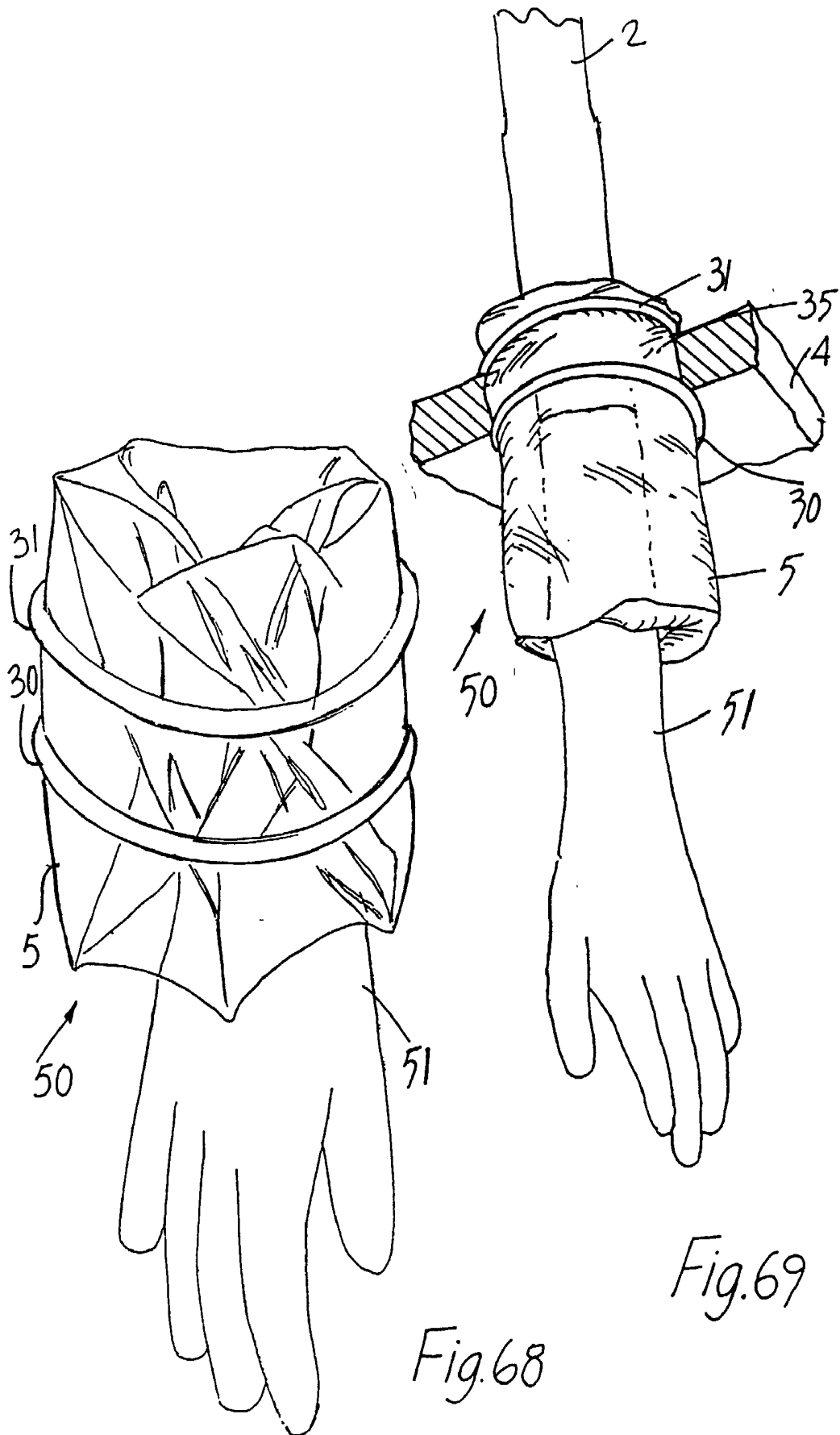

Fig. 61





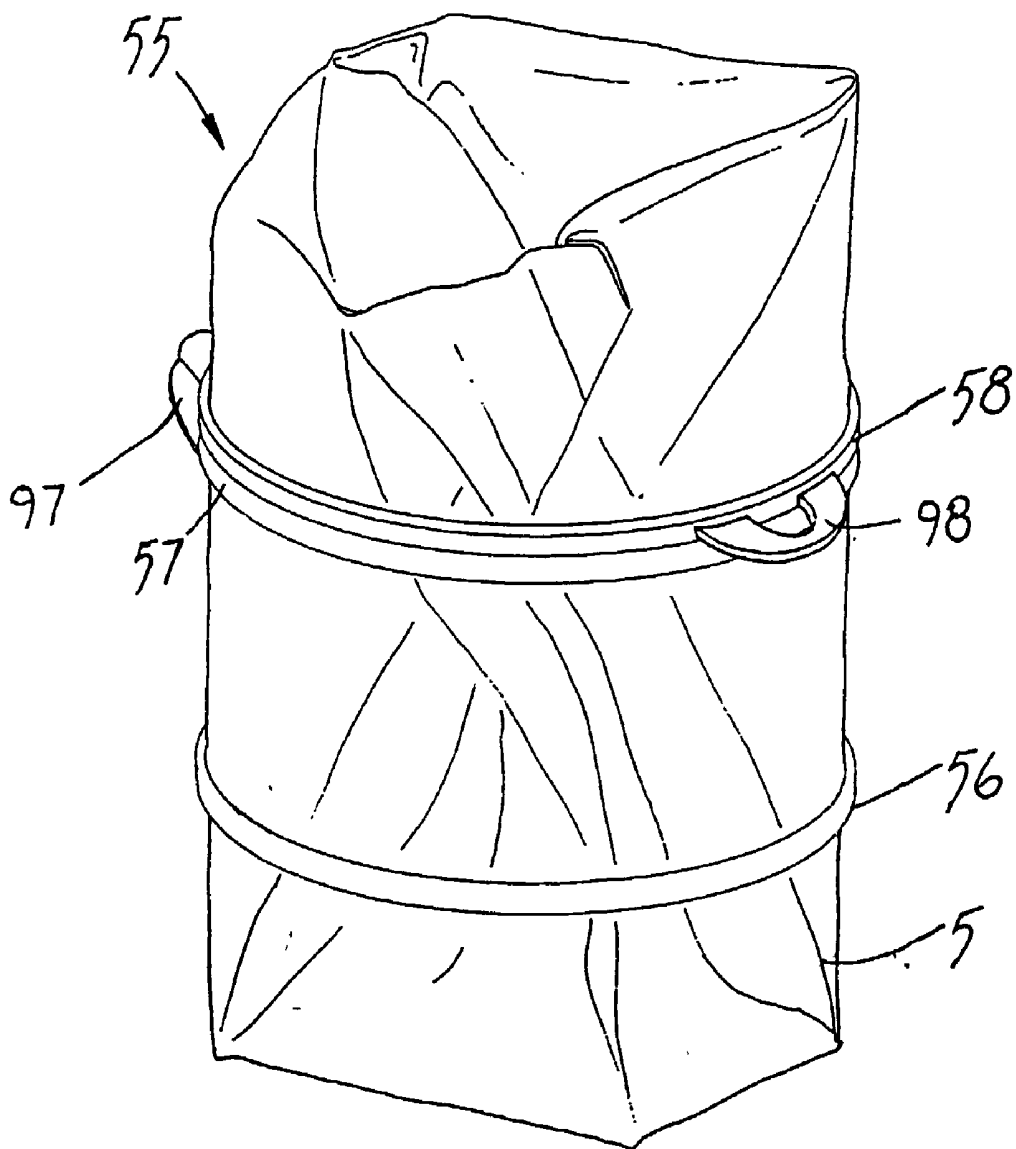
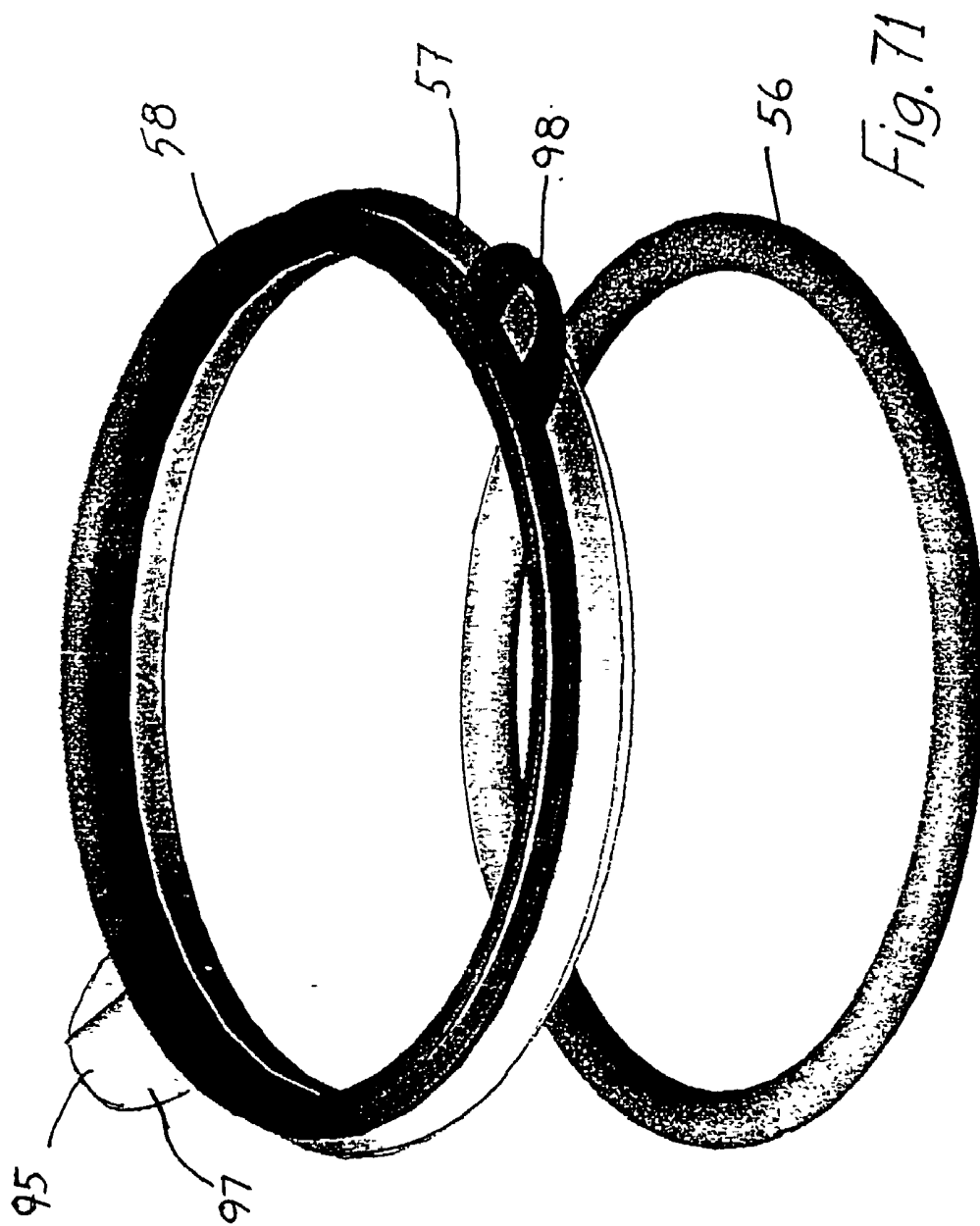
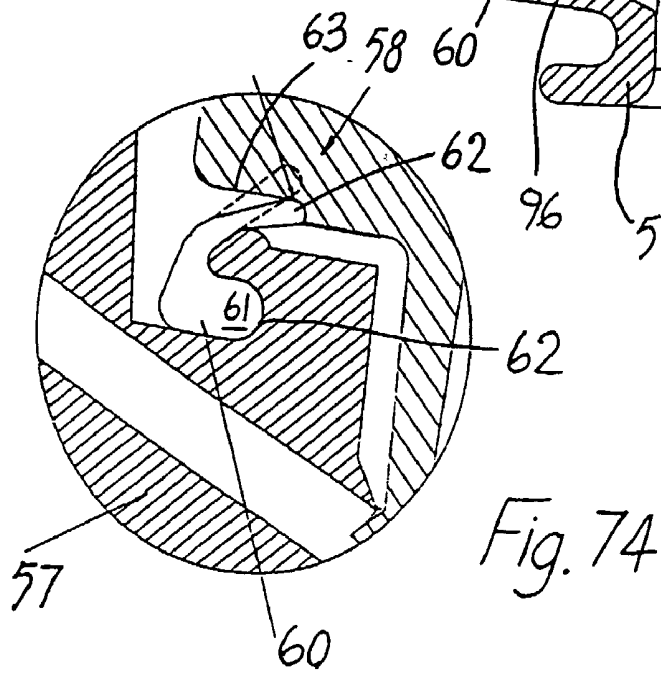
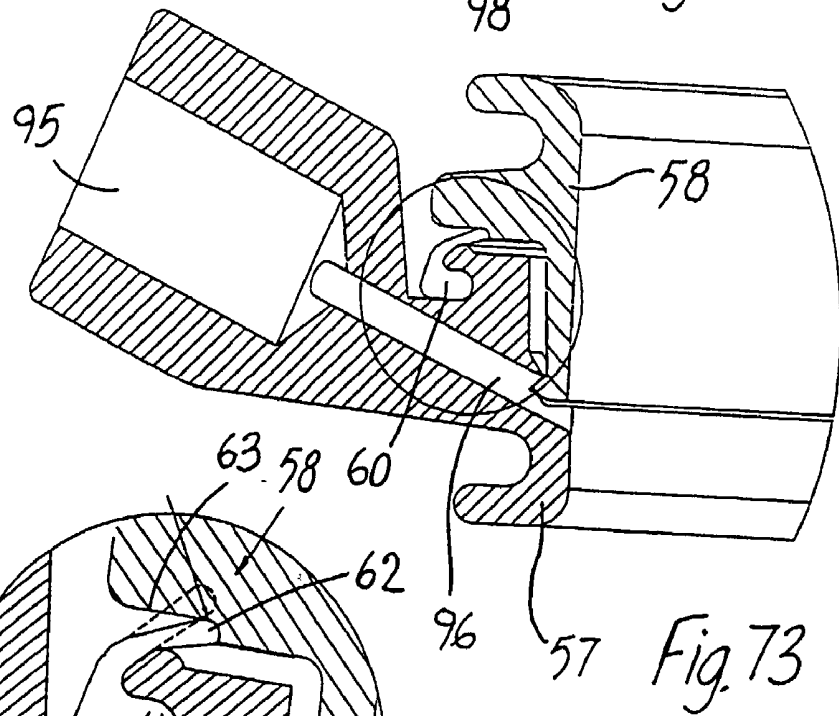
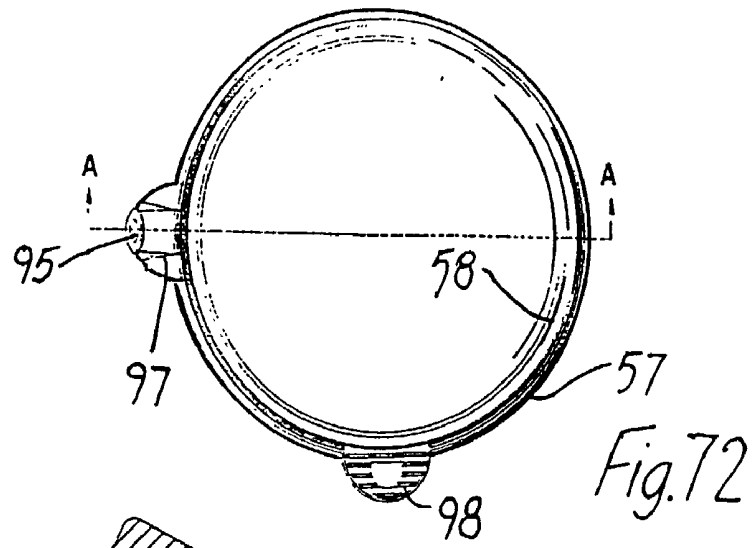
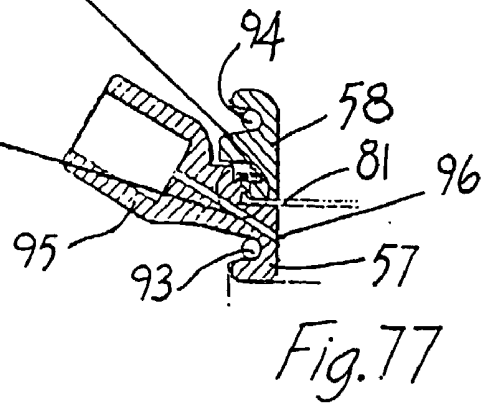
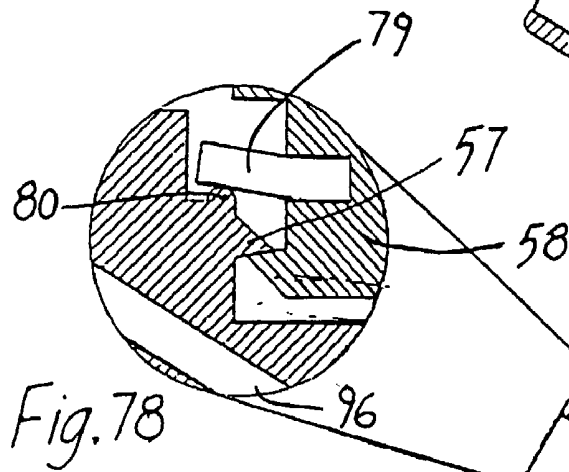
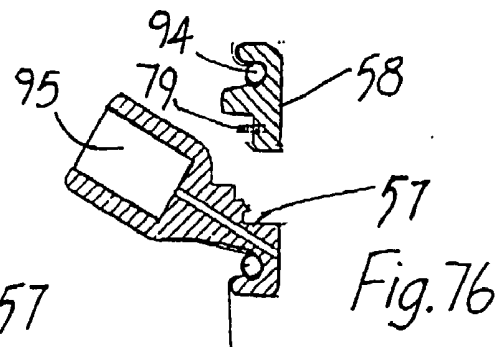
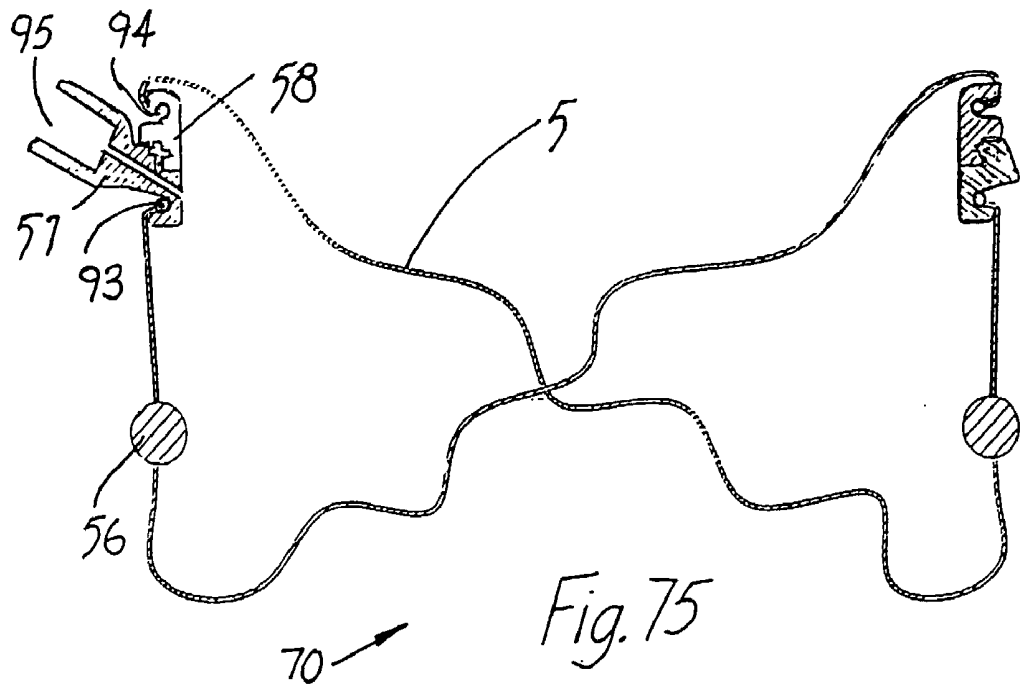

Fig. 70







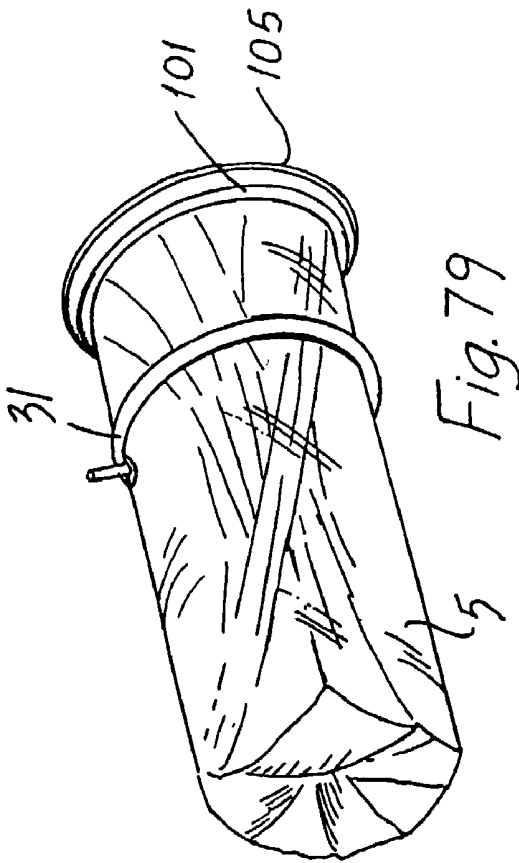

Fig. 79

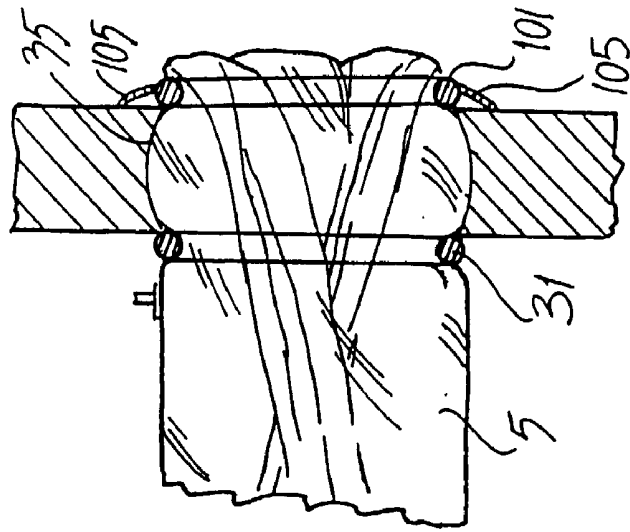

Fig. 80

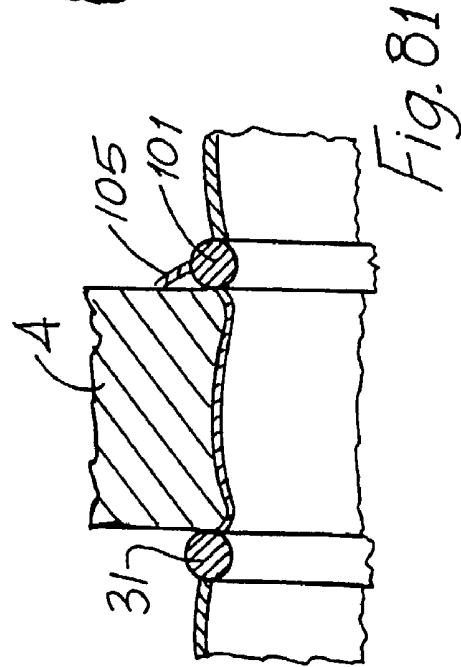
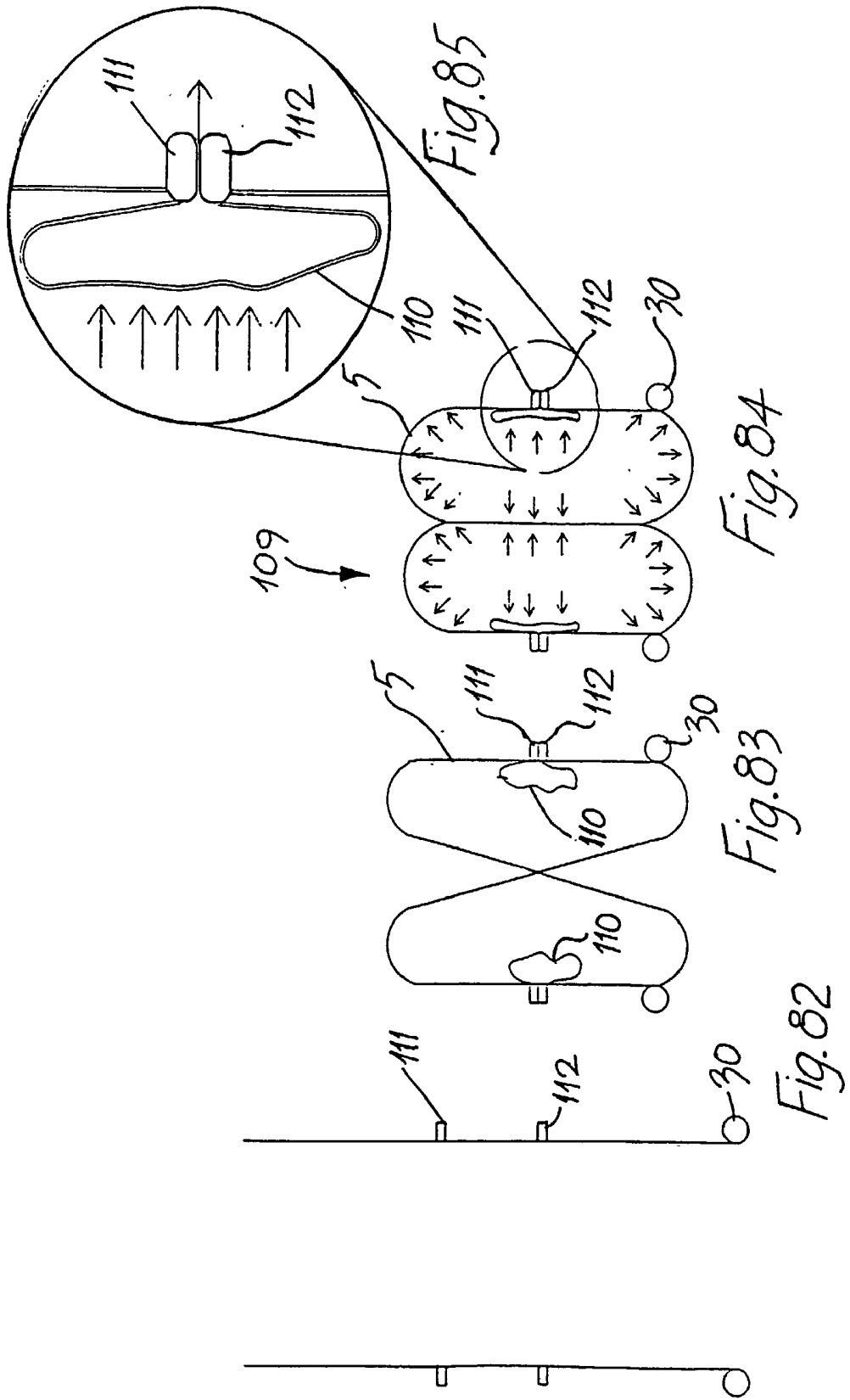
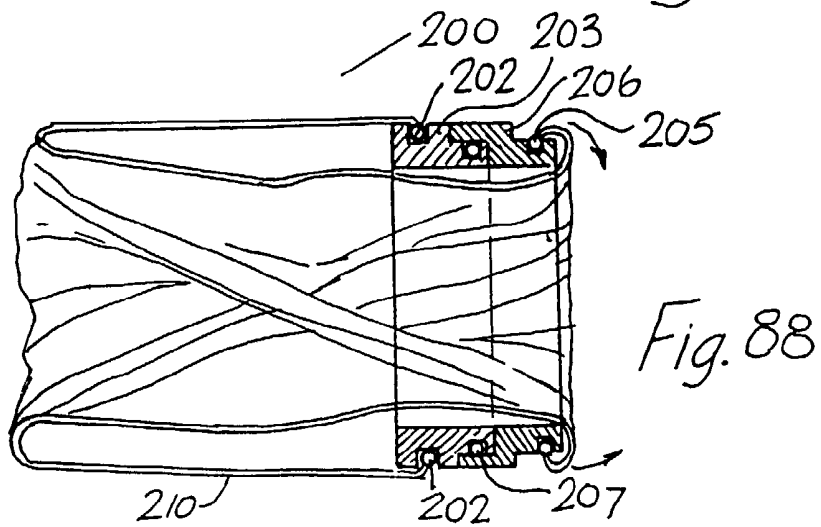
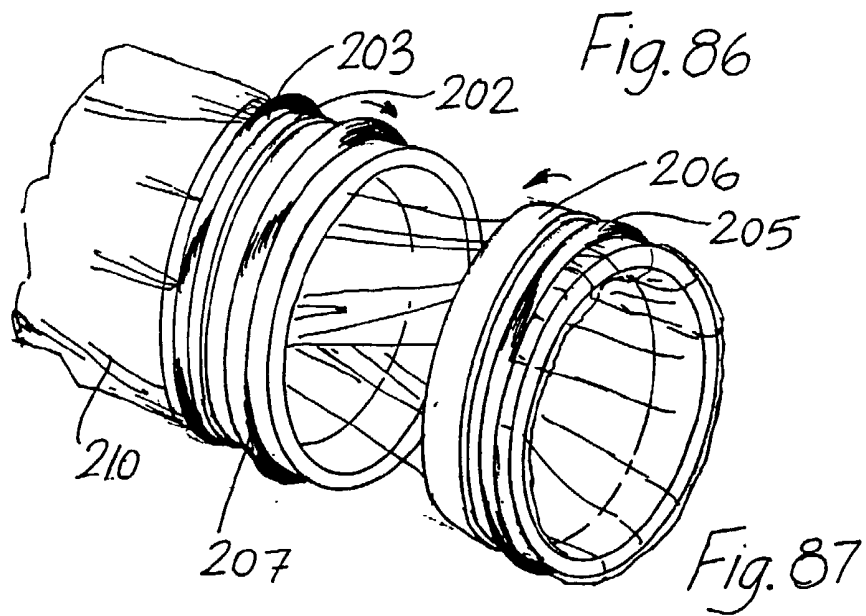
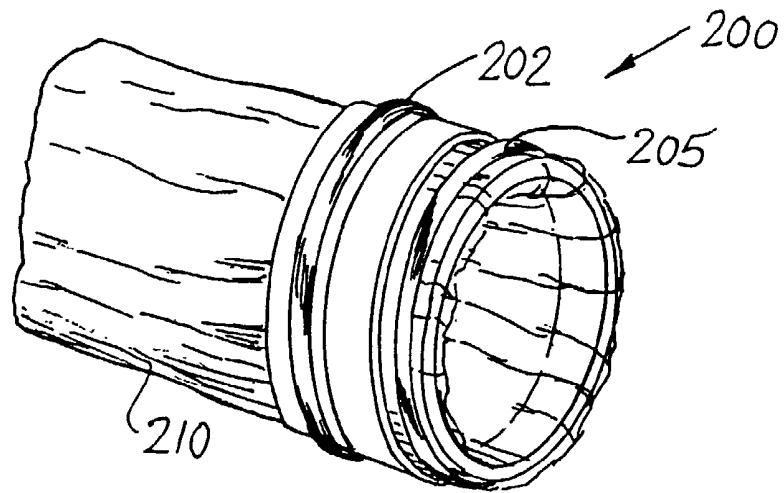

Fig. 81





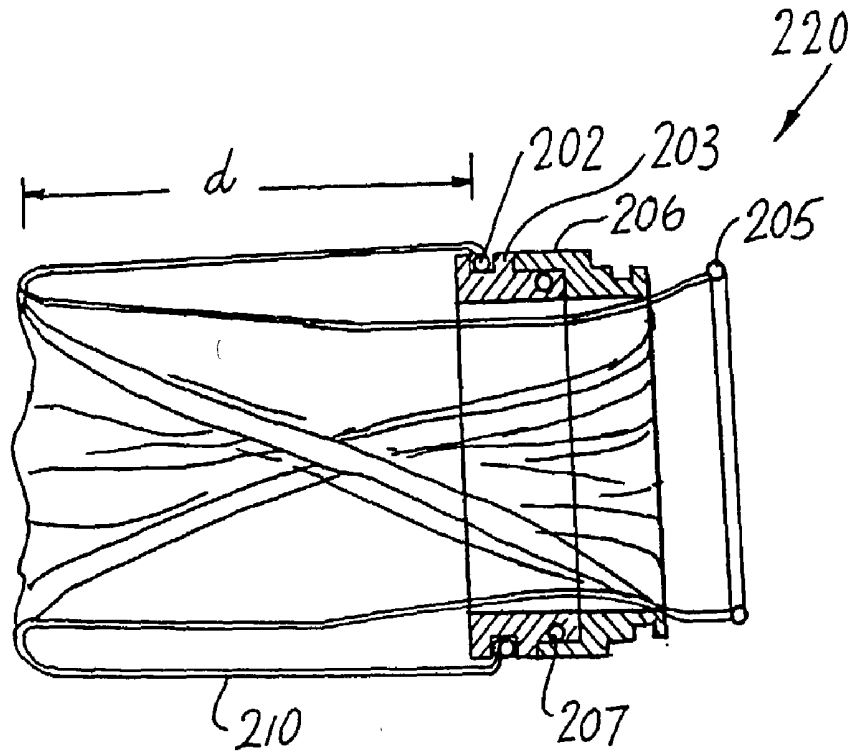

Fig. 89

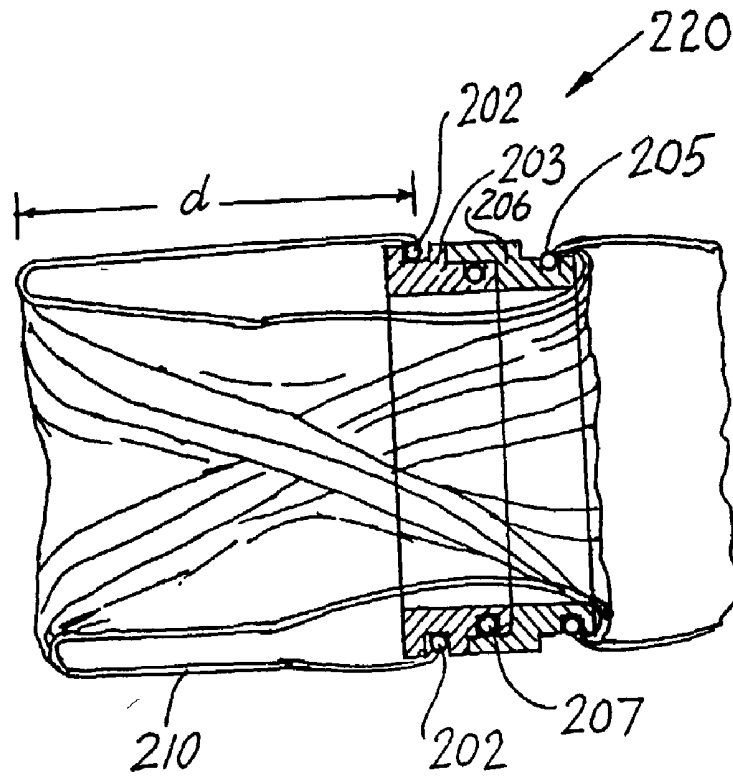
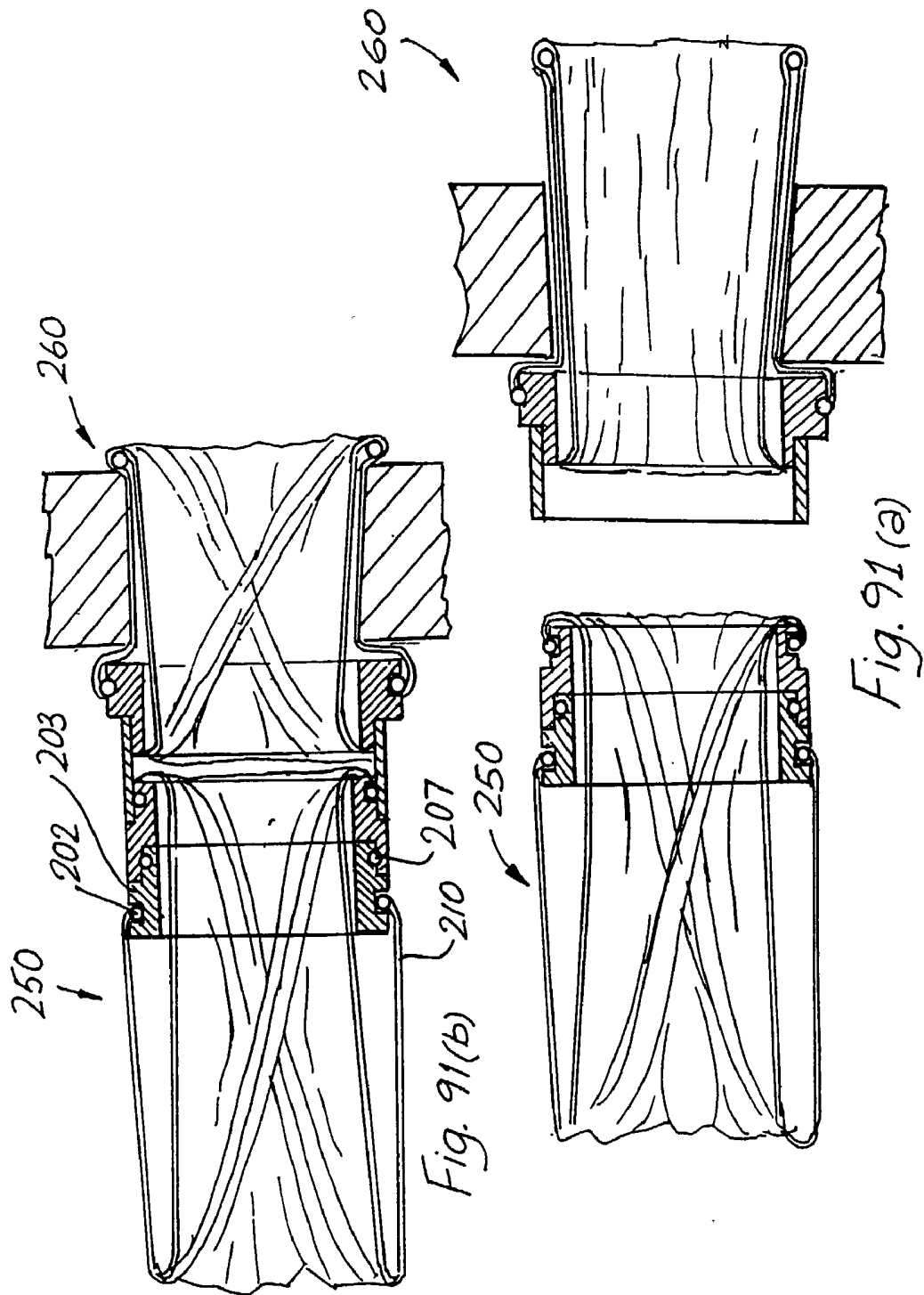
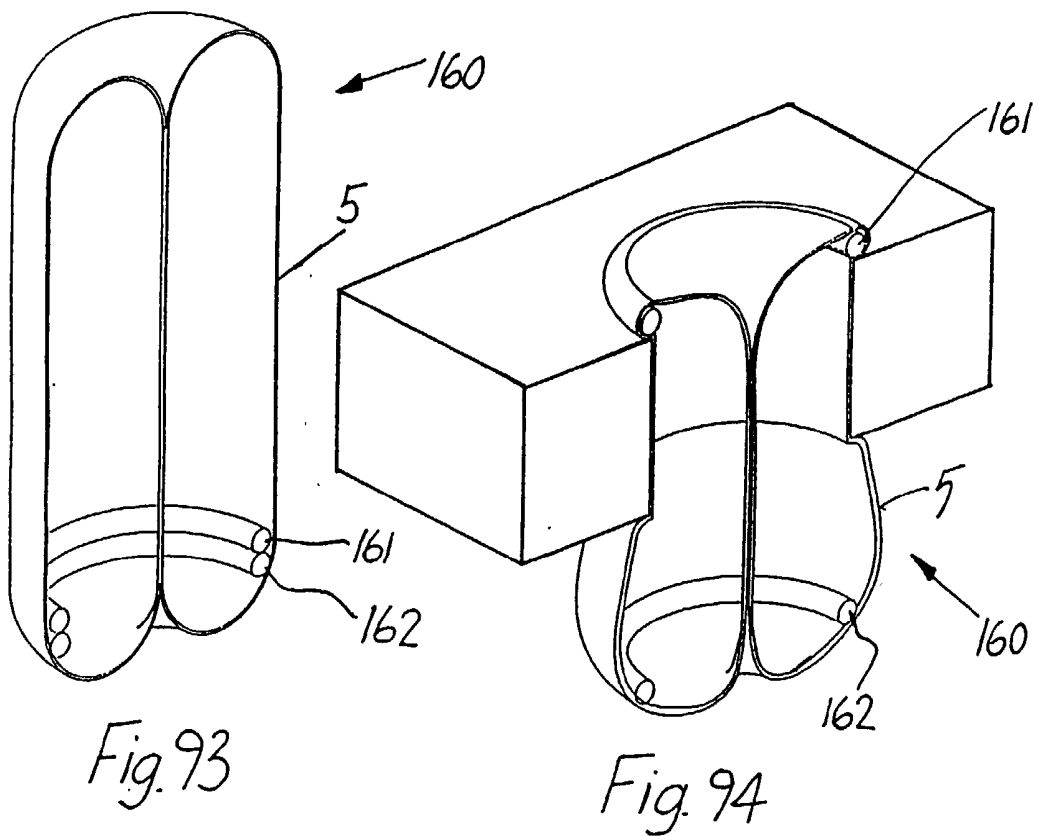
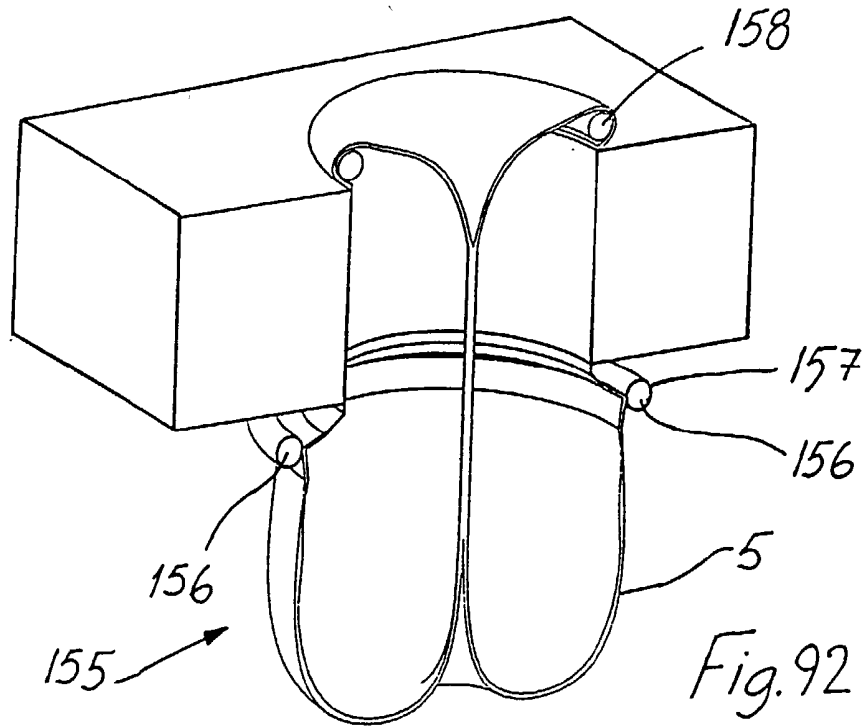

Fig. 90





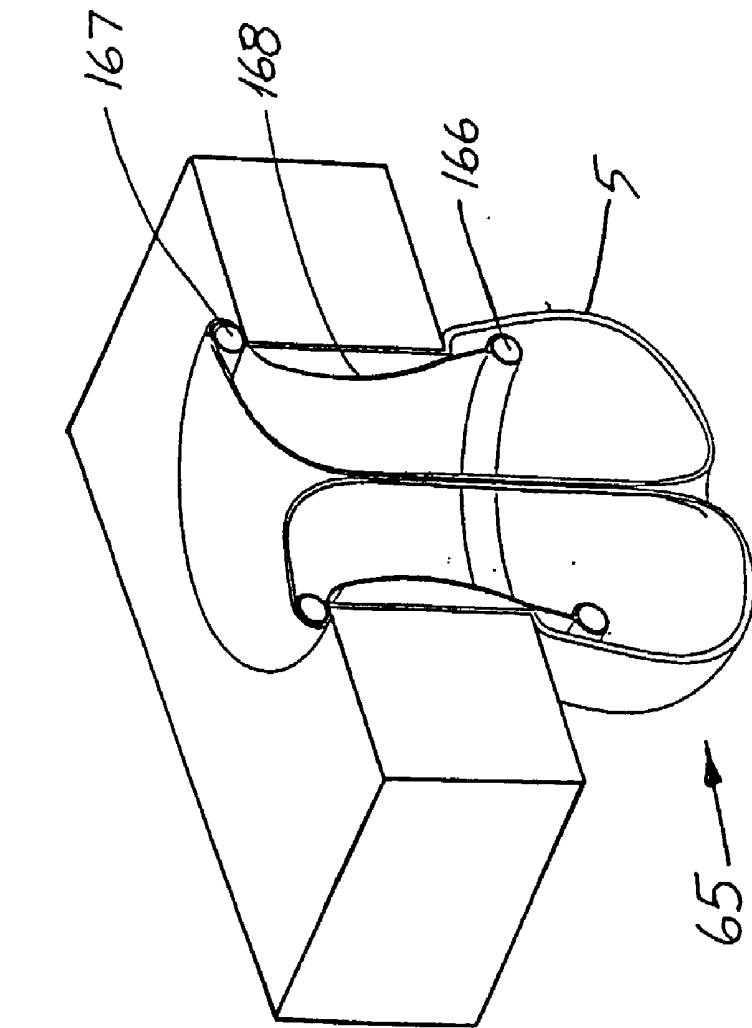

Fig. 95

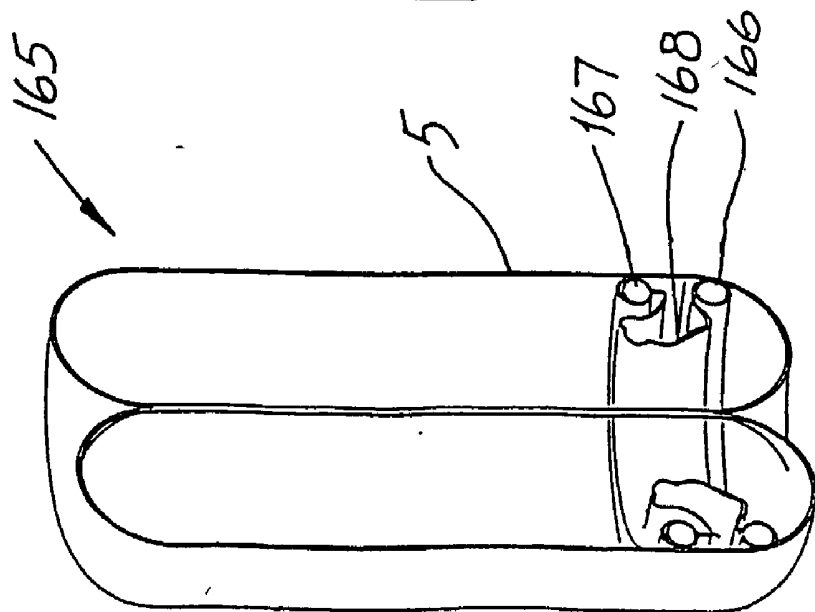

Fig. 96

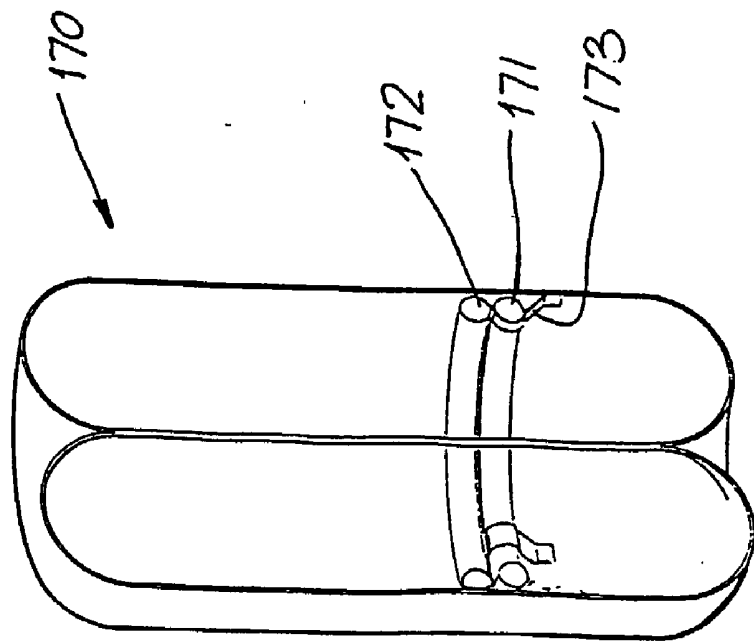

Fig. 97

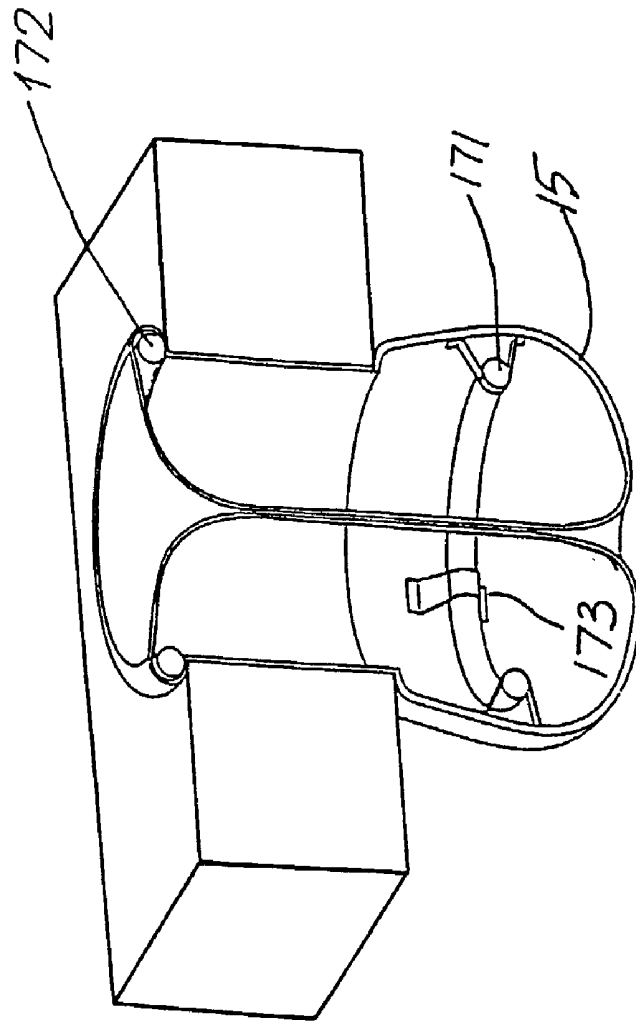
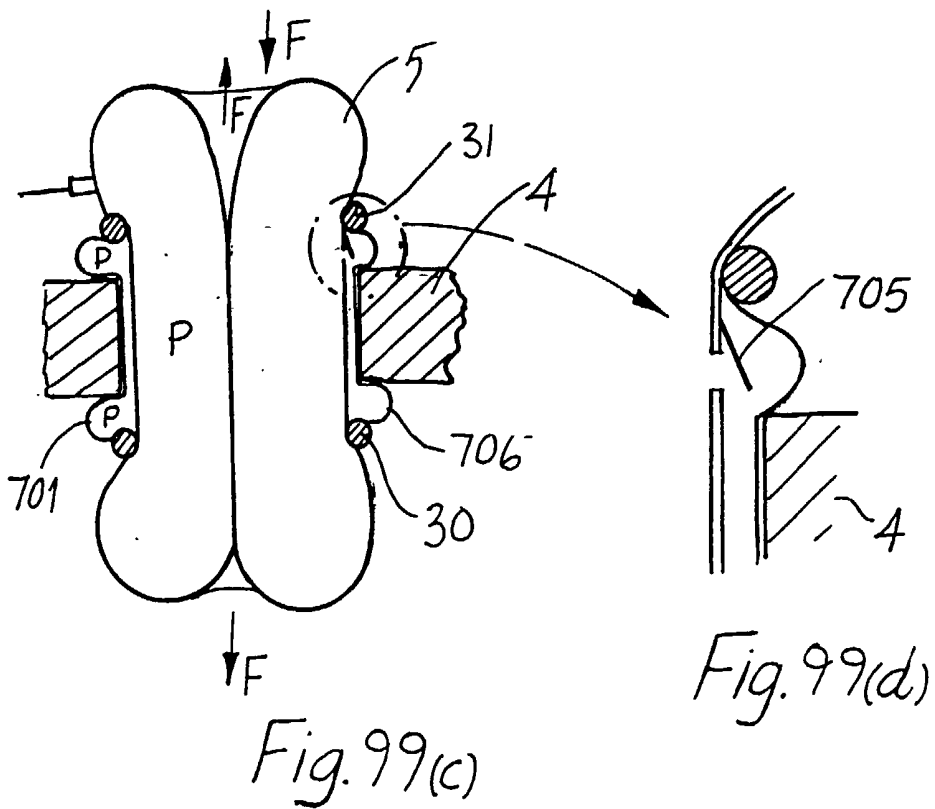
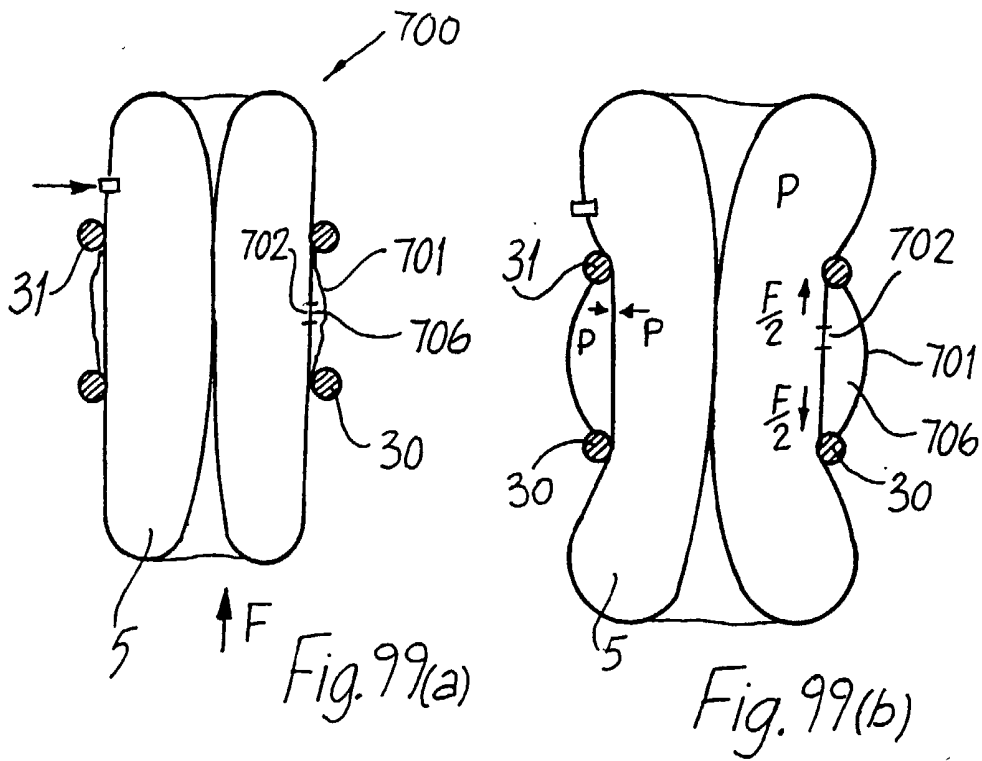

Fig. 98



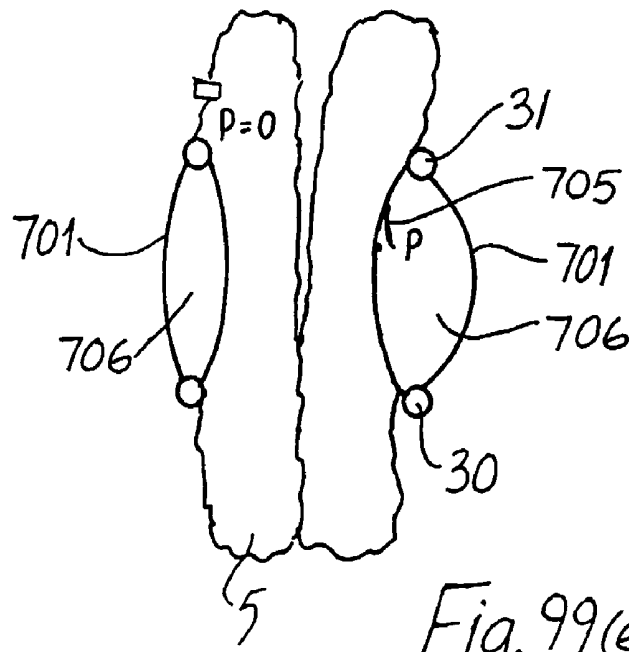

Fig. 99(e)

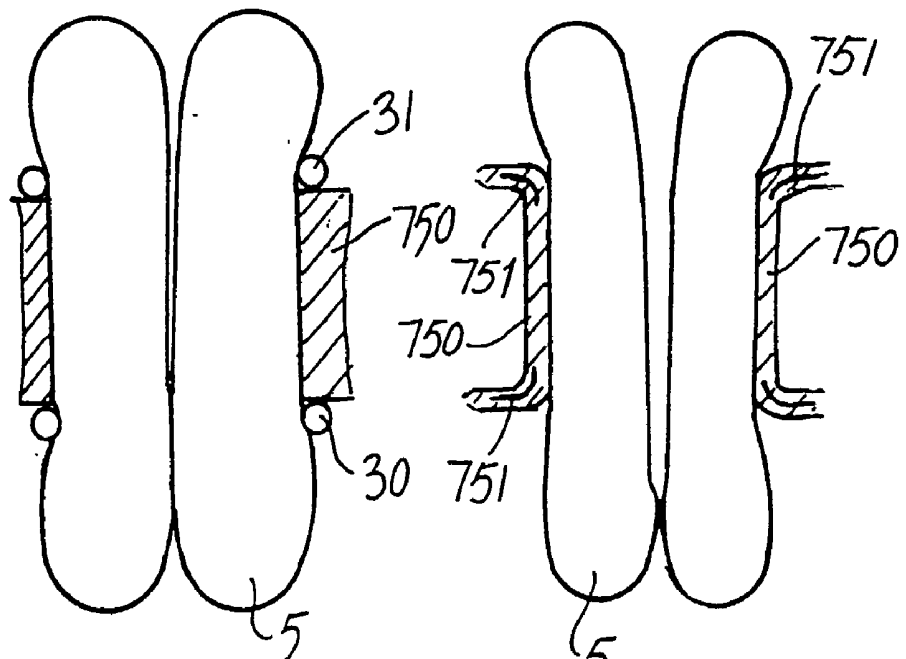

Fig. 100

Fig. 101

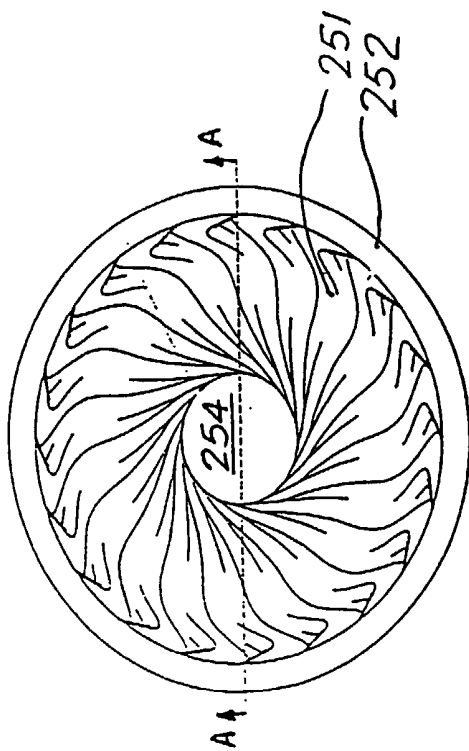

Fig. 102

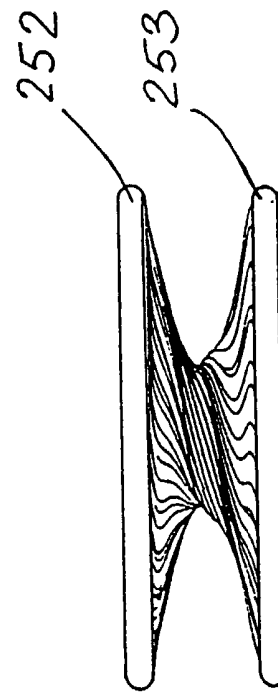

Fig. 103

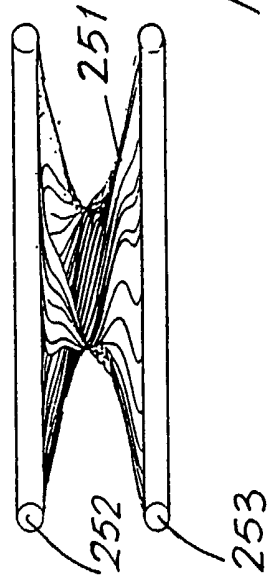

Fig. 104

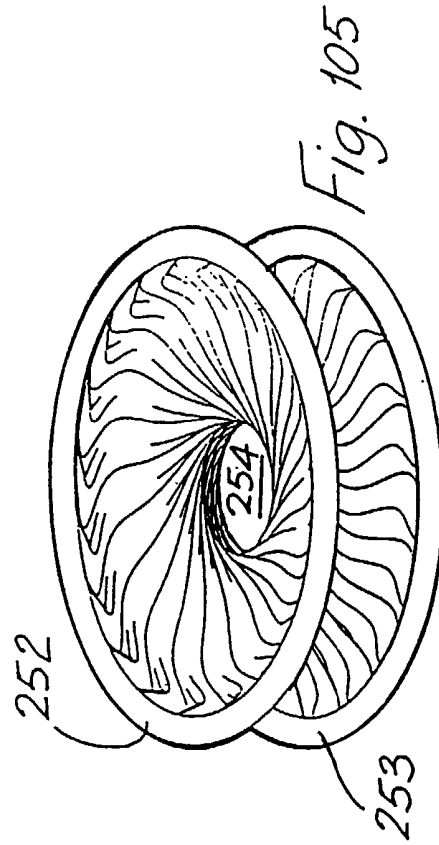
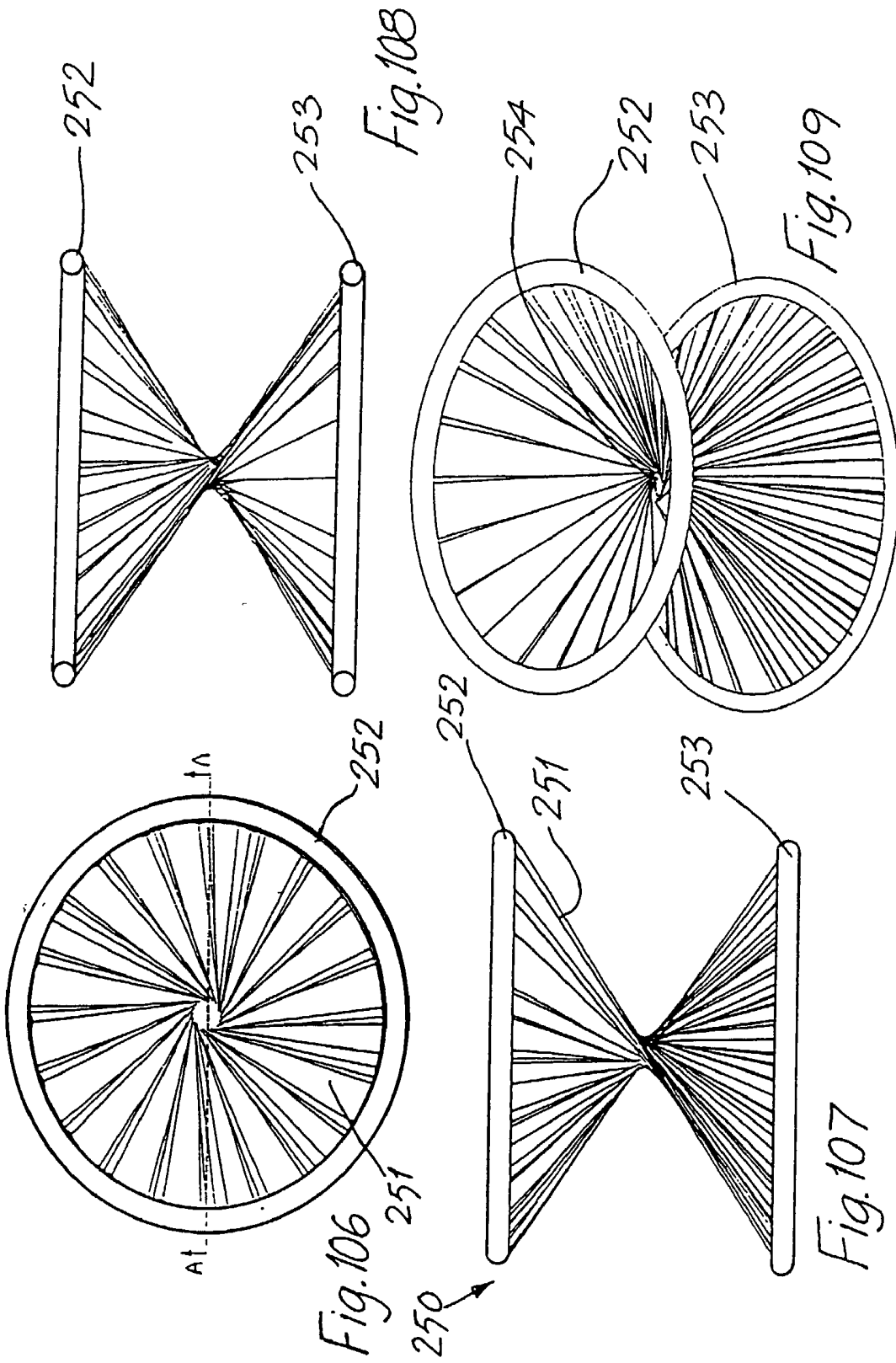
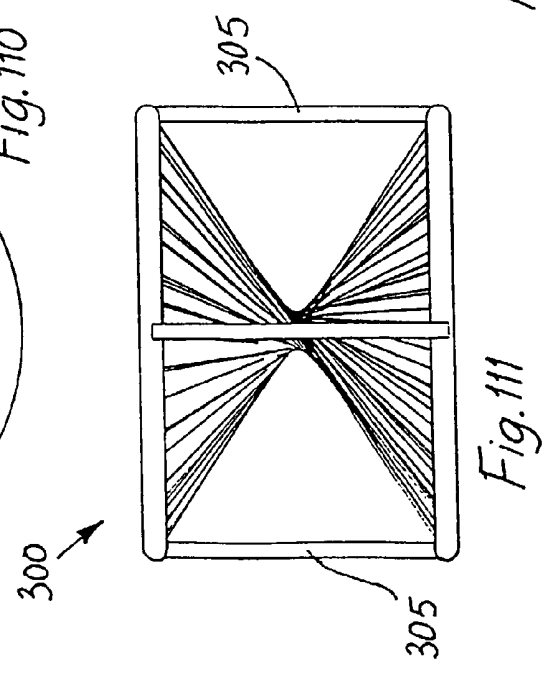
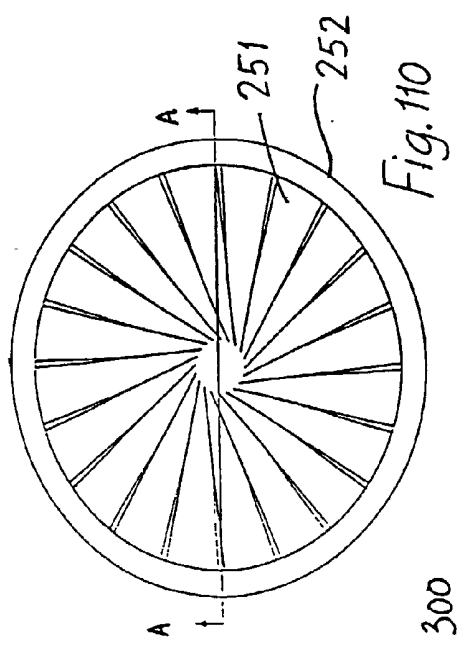
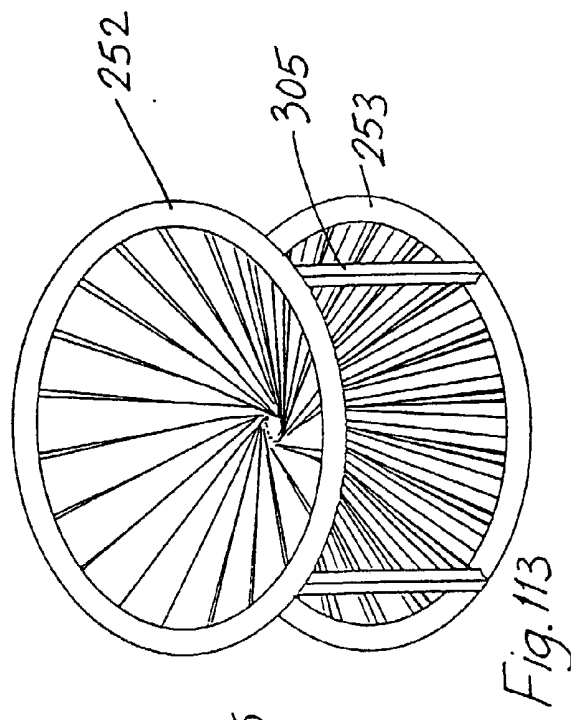
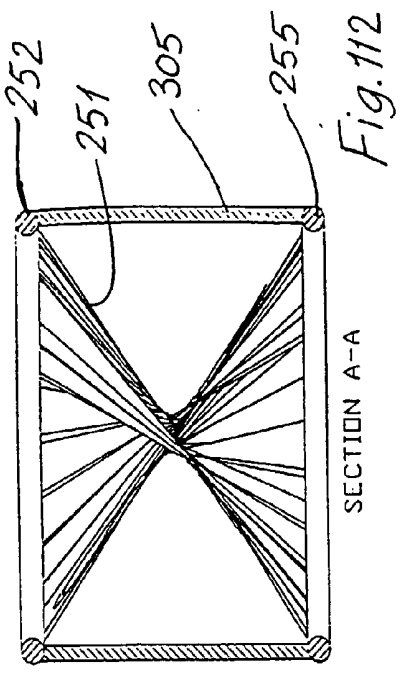
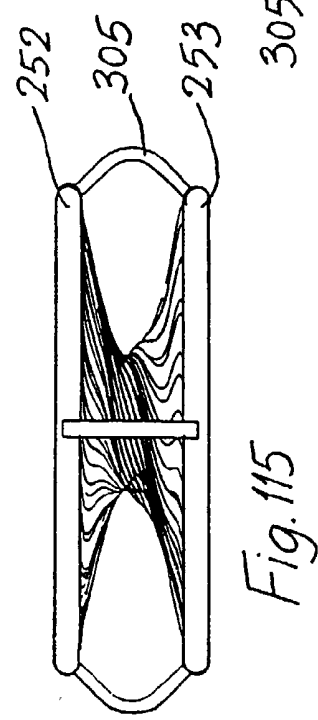
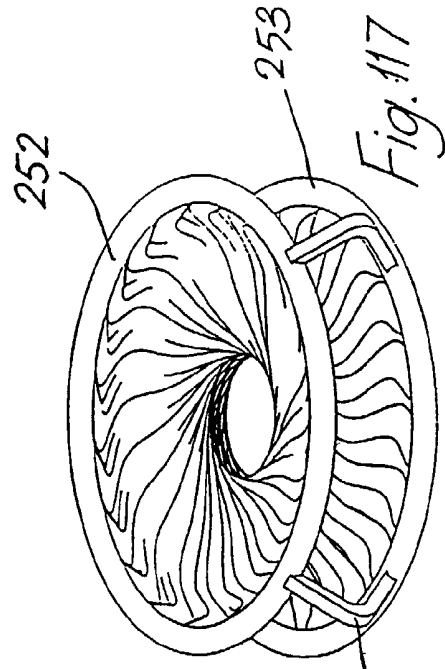
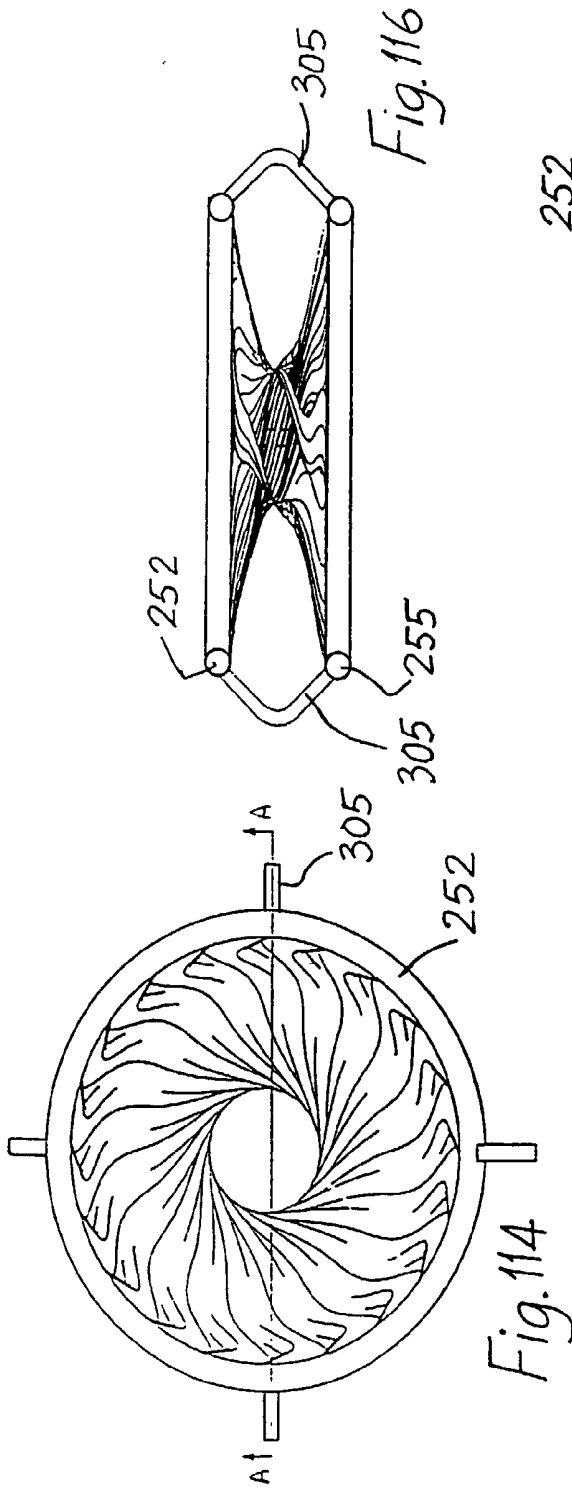

Fig. 105







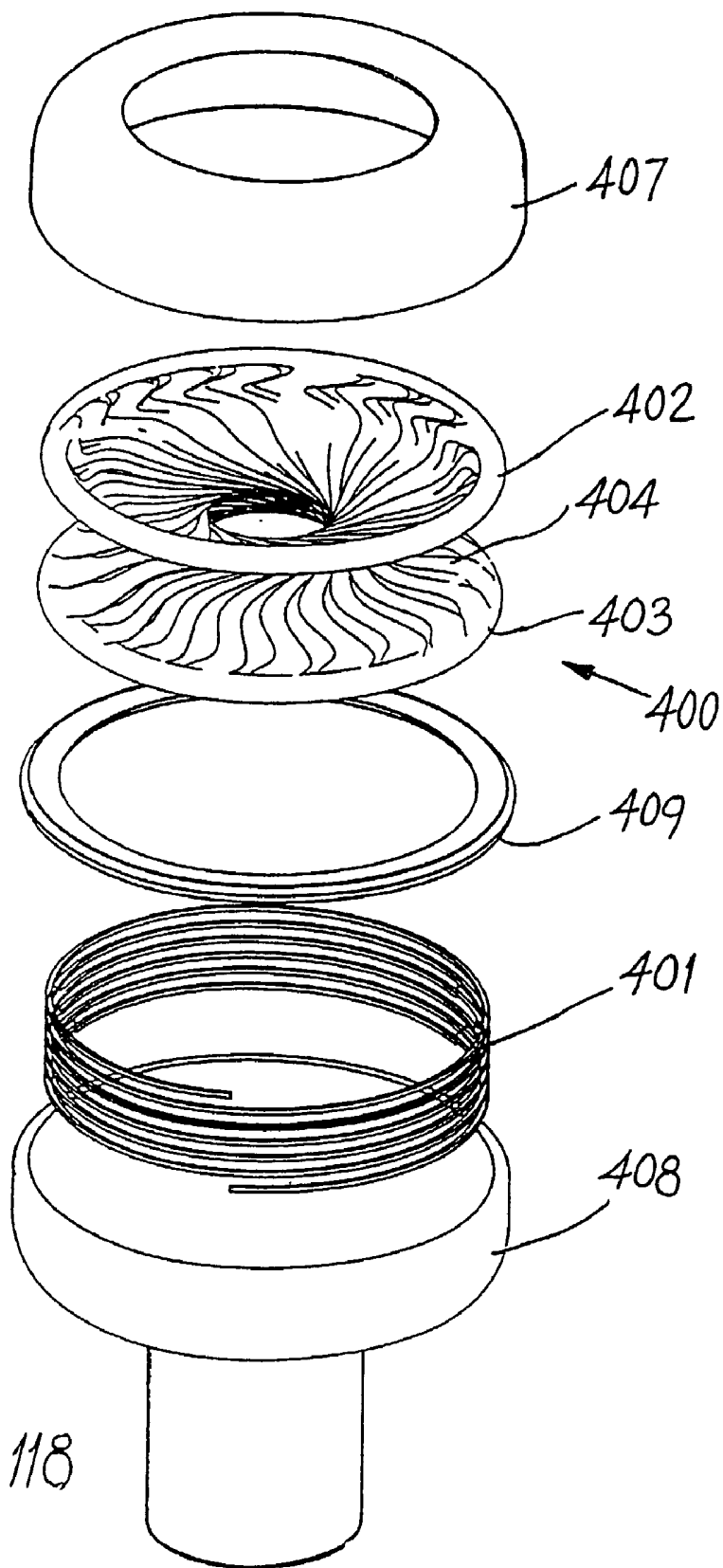

Fig. 118

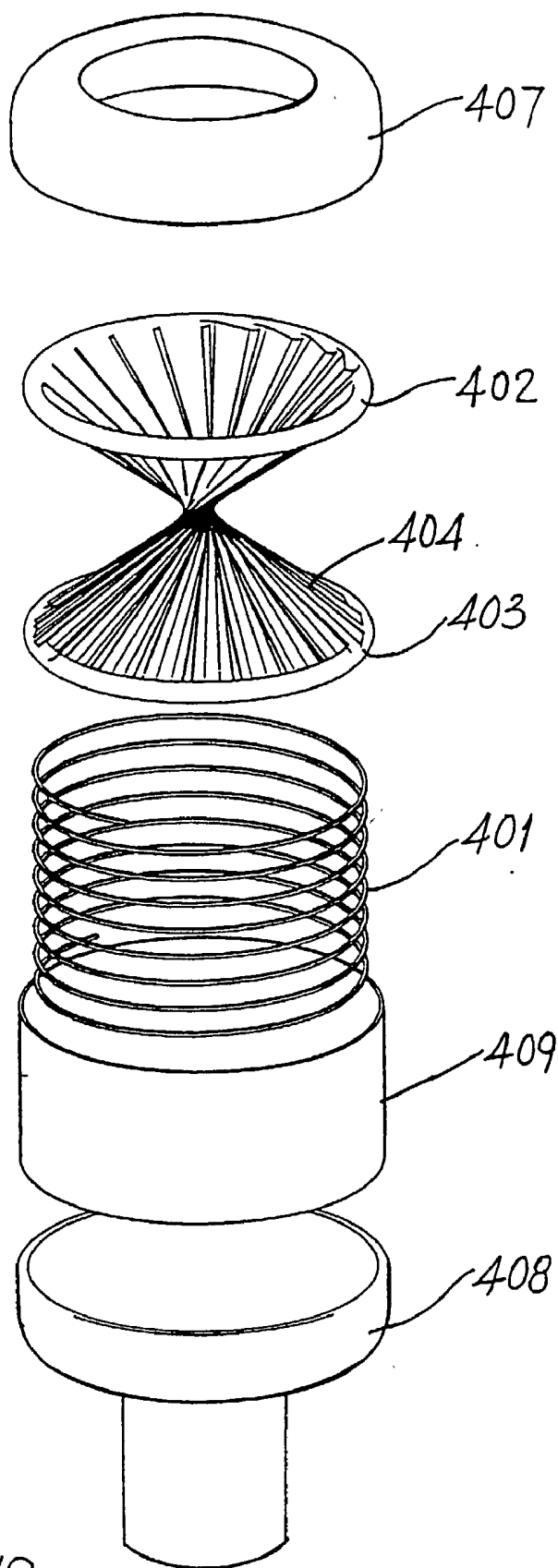
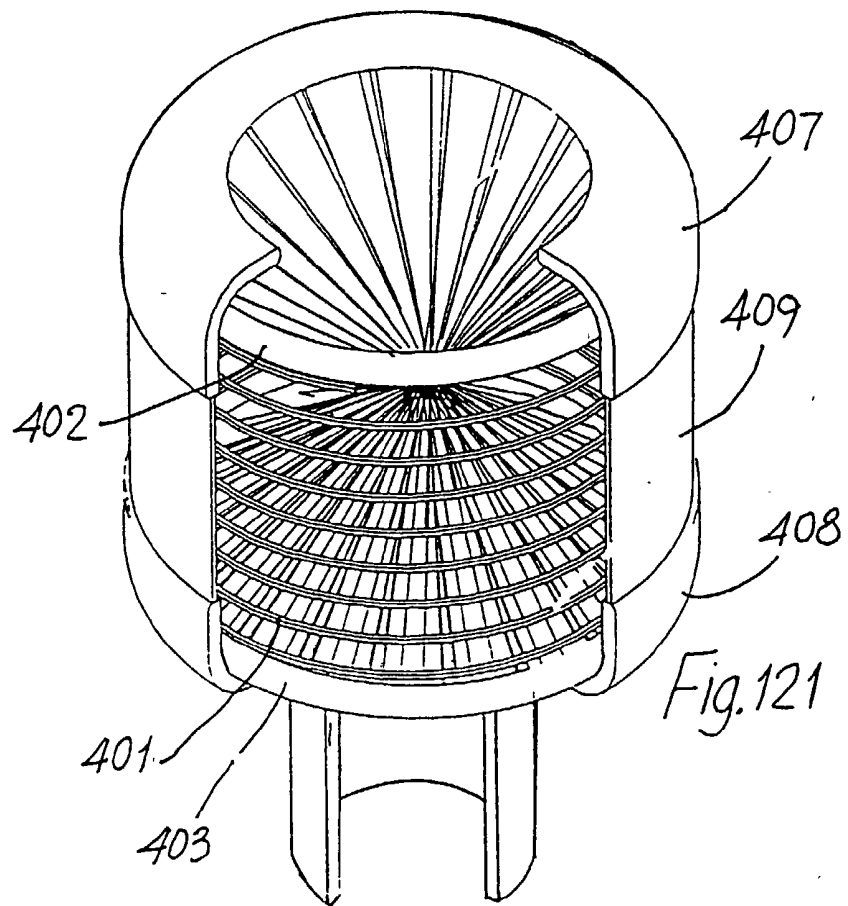
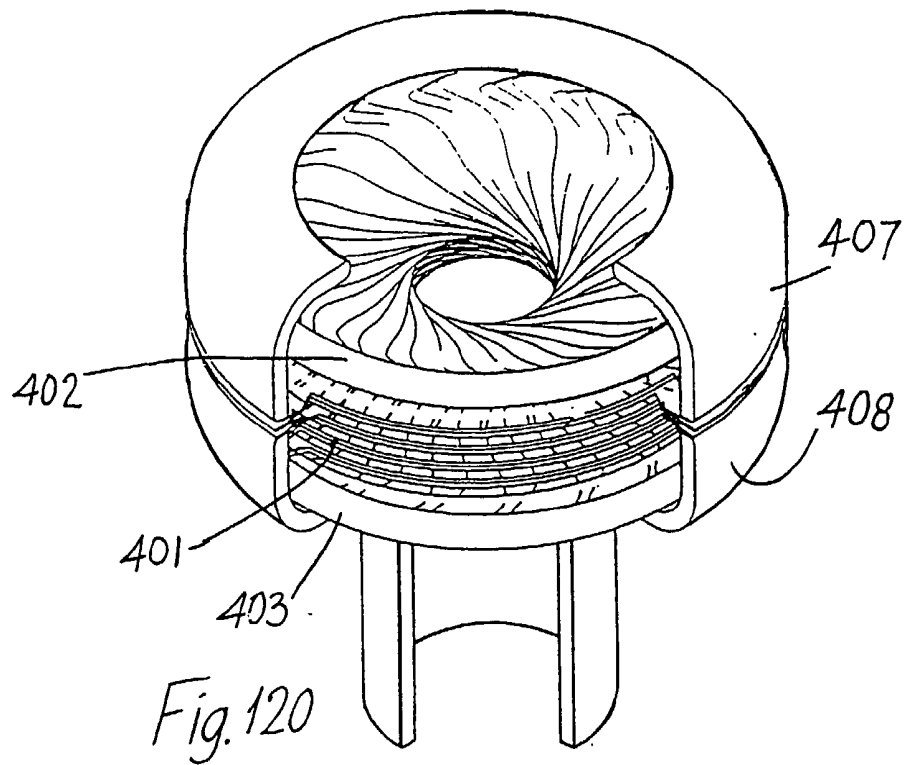
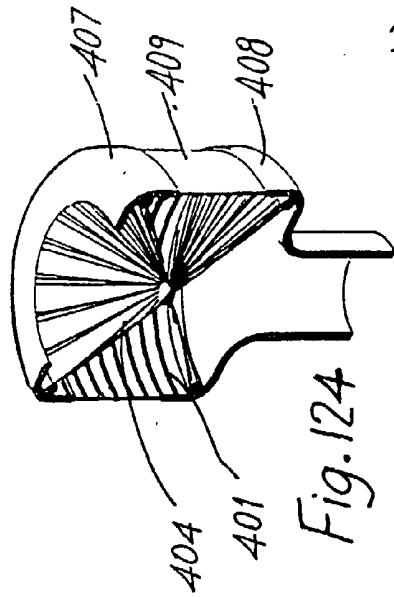
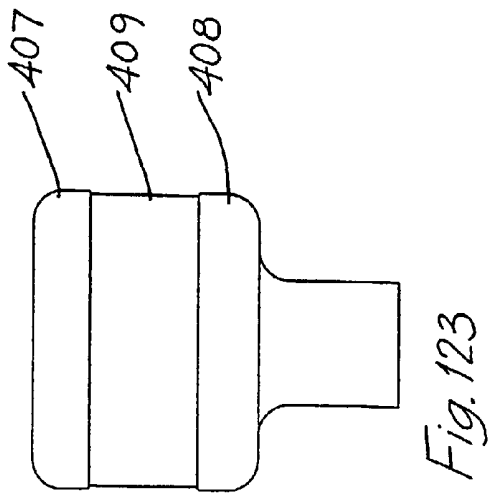
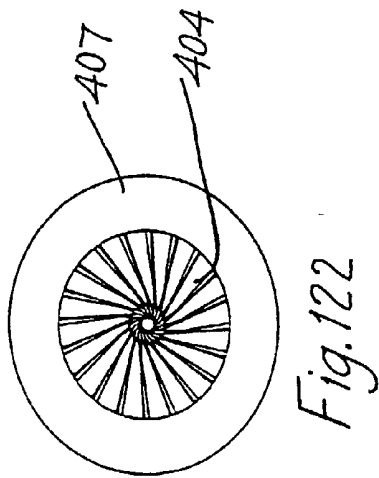

Fig. 119





38/40

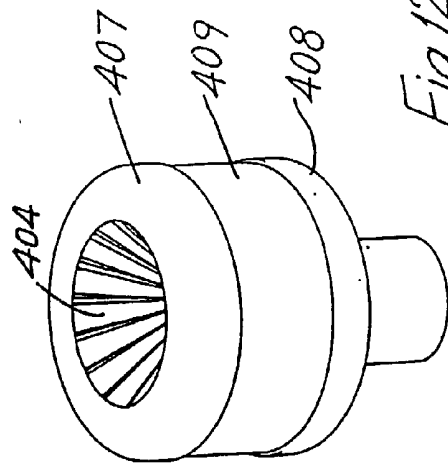

Fig. 125

Fig. 122

Fig. 123

Fig. 124

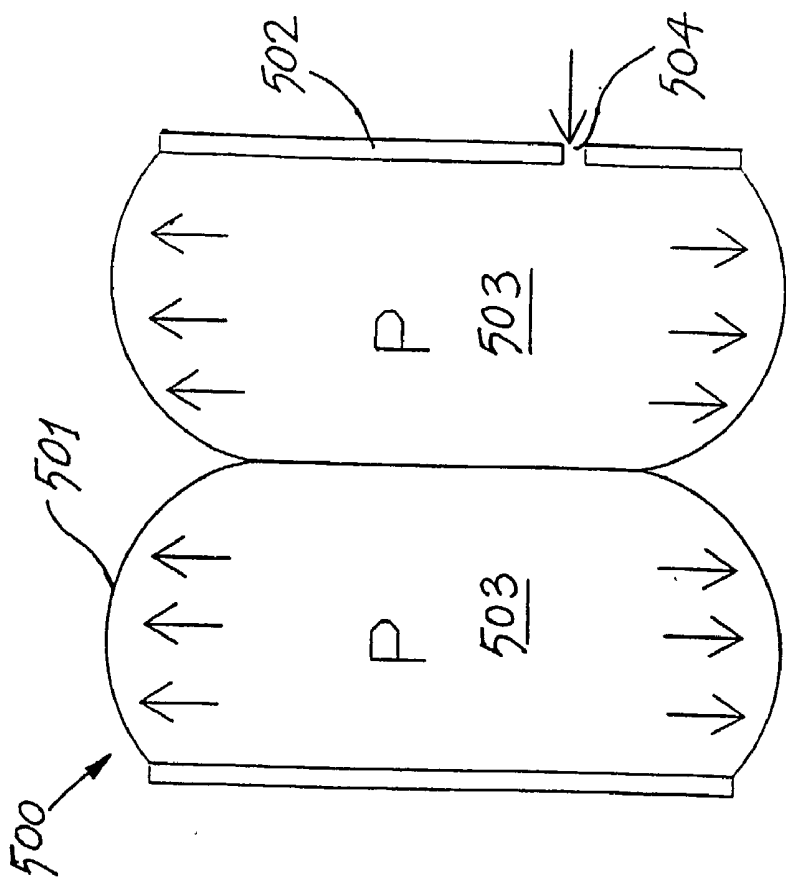

Fig. 127

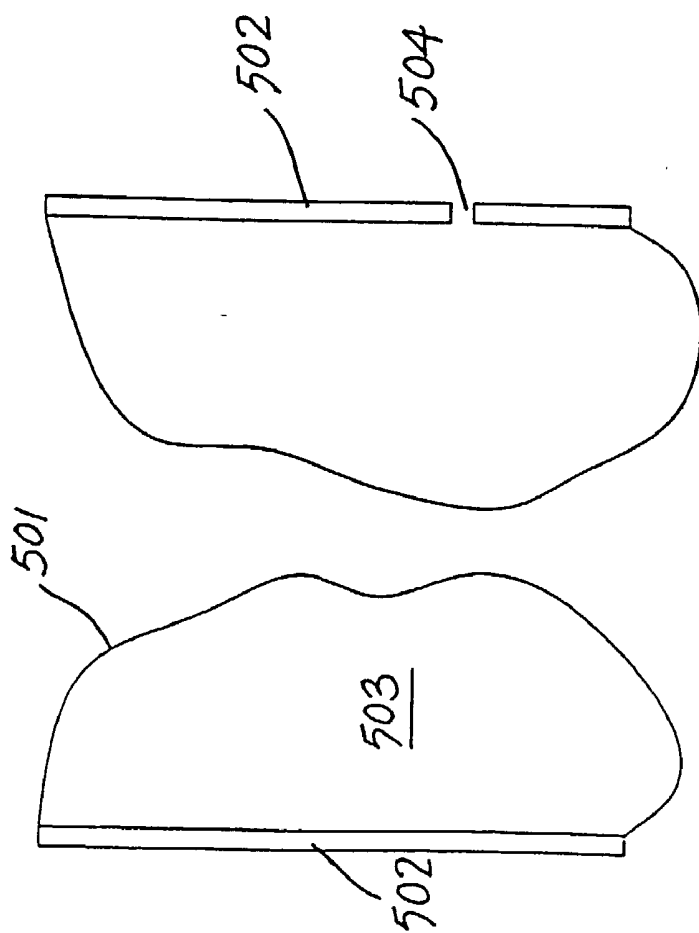

Fig. 126

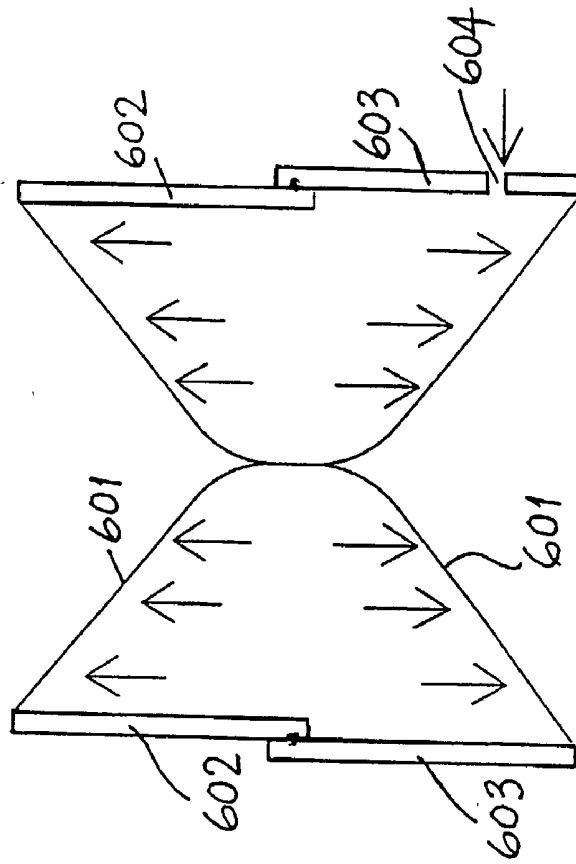

Fig. 129

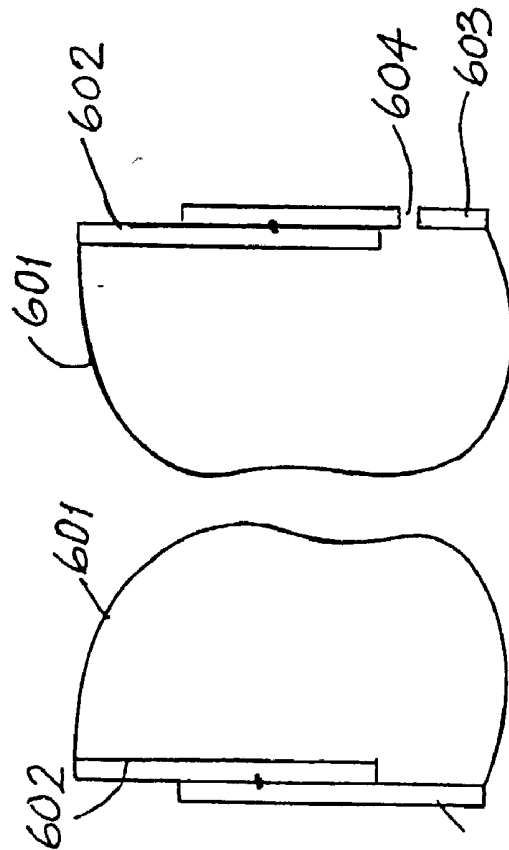

Fig. 128



## LAPAROSCOPIC SEALED ACCESS DEVICE

### INTRODUCTION

[0001] The invention relates to a medical device particularly for use in surgery to provide surgical access to the abdomen and maintain a gas-tight seal around the arm or an instrument during surgery. Surgery of this type is referred to as hand-assisted laparoscopic surgery or hand-access surgery.

[0002] Conventional abdominal surgery requires the creation of an incision in the abdominal wall to allow access to, and visualisation of the internal organs and other anatomical structures. These incisions must be large enough to accommodate the surgeons hands and any instruments to be utilised by the surgeon during the surgery. Traditionally the size of these incisions has been dictated by the need to see, retract and palpate internal bodily structures. While a large incision will provide access to the interior of the abdomen they are associated with longer healing times, are more susceptible to infection and result in unsightly scars.

[0003] Alternatives to open surgery exist in the form of endoscopic or laparoscopic surgery. In this method of surgery, the surgeon operates through small incisions using remotely actuated instruments. The instruments pass through the abdominal wall using devices called trocars. These working channels typically have a diameter ranging from 5 to 25 millimetres. Vision is provided using a laparoscope which is typically 20 to 25 centimetres long and uses fibre-optic technology or a CCD camera to provide the operator with a picture of the interior of the abdomen. The abdomen must be insufflated with a gas such as carbon dioxide or nitrogen to maintain a bubble effect and provide a viable working space for the operator to perform the surgery unhindered by the lack of space. This insufflation creates a working space known as the pneumoperitoneum. Trocars through which instruments are inserted are constructed to prevent loss of the gas through them resulting in collapse of the pneumoperitoneum.

[0004] The benefits of laparoscopic surgery are numerous. Recovery times have been shown to be reduced due to the absence of a large incision. This has benefits for the patient, the health care organisation and society. The benefits to the patient are reduced stay in hospital, faster mobilisation and return to normal activity. The benefits to the health care organisation is also due to the reduced stay in hospital which is often the most expensive aspect of health care provision. Society benefits in faster return to work and normal activity of the patient.

[0005] However, not all surgical procedures can be performed laparoscopically. Surgery requiring the removal of large organ specimens, such as surgery for removal of the colon, has traditionally been hampered by the small incisions used for the introduction of laparoscopic instruments in the surgery.

[0006] The other major disadvantages of laparoscopic surgery are due to the complex nature of the technique. Surgeons who wish to practise laparoscopic surgery must spend much time training to master the technique. The success of laparoscopic surgery depends on the skill of the surgeon to manipulate organs and carry out delicate tasks using remotely actuated instruments. Unfortunately in lap-

aroscopic surgery the surgeon is insulated from the material that they are working on. This deprives the surgeon of tactile feedback and the ability to palpate delicate structures. The surgeon's most effective instrument, the hand, is reduced to a device that must simply actuate instruments that are inherently lacking in dexterity and operability due to the constraints on their design placed by the nature of the narrow channels in trocars through which they must pass. Another disadvantage of laparoscopy is that the image viewed by the surgeon is a two dimensional image on a video screen. The surgeon loses three dimensional perspective of depth and distance and awareness of the proximity of other structures during video laparoscopy.

[0007] These disadvantages have led to long learning curves for the practitioners of laparoscopic surgery, required highly skilled and coordinated surgical teams and has limited the application of laparoscopic surgery to relatively simple surgical procedures.

[0008] Recently, new surgical techniques have been developed that combine the advantages of both open surgery and laparoscopic surgery. In these new techniques surgery is carried out using a laparoscopic approach with the addition of a slightly larger incision to allow the surgeon to insert a hand into the insufflated abdomen. This is often referred to as hand-assisted laparoscopic surgery or HALS.

[0009] HALS allows surgeons to regain the tactile feedback and three-dimensional perspective lost in the conversion from open to laparoscopic procedures. It also permits rapid finger dissection, enhanced retraction capabilities and simplified haemostasis. There are several publications in the literature describing procedures carried out using a hand-assisted approach. These include total and sub-total colectomy, rectopexy, Nissen's fundoplication, gastrectomy, splenectomy, nephrectomy, pancreatectomy and others. Some of these procedures were previously performed using an open technique only. Over the past few years several centres have been investigating HALS with surgical device companies and increasing the literature on the subject. With the advent of surgical devices for facilitating HALS it is expected that more open surgical procedures will be converted to HALS procedures.

[0010] The key to the success of hand-assisted laparoscopic surgery will be to provide a device that will seal to the wound edge and to a surgeons arm to maintain the pneumoperitoneum required. The device should provide freedom of movement including rotational, lateral and translational. In addition, it should be possible to use laparoscopic instruments with the device.

[0011] Various hand access devices have been proposed however, to date, no hand access device is available that adequately addresses these key issues.

[0012] U.S. Pat. No. 5,366,478 (Brinkerhoff et al) describes a device which is said to be for use during endoscopic surgery. The device has two inflatable toroidal sections connected by a transitional section. The transitional section is said to function to allow the passage of air from one toroid to the other toroid on inflation of the device. Each toroidal section contains a flexible stiffening ring. The stiffening ring in the outer toroid is illustrated in a position floating above the abdominal wall after inflation. It is not clear how this device provides a seal however in any event

it would be difficult to pass an object such as a surgeon's forearm through a lumen in the transitional section, because of frictional resistance to the movement of the object relative to the transitional section.

[0013] A medical device for forming an external extension of the pneumoperitoneum is described in U.S. Pat. No. 5,480,410 (Cuschieri et al). The device includes an enclosure sealed into a trocar puncture site in an abdominal wall. Insufflation gas passes from the body cavity into the enclosure inflating it. A number of valved openings are provided on the device to enable access to the enclosure interior.

[0014] In U.S. Pat. No. 5,514,133 (Golub et al) describes an endoscopic surgical apparatus, to enable a surgeon to access a surgical site through an opening. The apparatus includes two plates, which engage the outer and inner surfaces of the abdominal wall, and a sealing member, which inhibits the flow of gas through the opening. It is expected that the seal in this apparatus would not maintain complete insufflation of the body cavity as gas can gradually leak out through the flapvalves and seal. The valve configuration also makes it impossible to extracorporealise an organ, which is preferred in hand-assisted surgery devices. The device also has a complicated construction.

[0015] A surgical glove suitable for use in endoscopic surgical procedures is described in U.S. Pat. No. 5,526,536 (Cartmill). The glove has an inflatable wrist section, which when inflated, is said to provide a seal between the surgeon's hand and the body wall. The surgeon's gloved hand must remain in the body cavity to maintain insulation of the body cavity. Therefore this device also restricts the actions of the surgeon.

[0016] U.S. Pat. No. 5,522,791 (Leyva), describes an abdominal retractor, which retracts an abdominal incision providing access for a hand into a body cavity. The hand is passed into a sleeve and the other end of the sleeve is mounted to the retractor.

[0017] U.S. Pat. No. 5,545,179 (Williamson) describes an access assembly, which provides access for surgical instruments to a body cavity during surgery. A sealing sleeve is inflated to form a large balloon portion within the body cavity, the balloon portion being constrained to remain within the body cavity. It is difficult to retract a surgical instrument through a balloon portion and out of the body cavity, because of frictional resistance to the movement of the surgical instrument relative to the balloon sleeve.

[0018] A method of performing laparoscopic surgery is described in U.S. Pat. No. 5,636,645 (Ou), which includes the steps of inserting a surgeon's gloved hand into a body cavity and sealing the hand to body tissue surrounding the cavity. This method restricts the actions of the surgeon because the surgeon's gloved hand must remain in the body cavity sealed to the surrounding tissue to maintain insufflation of the body cavity. The seal between the surgeon's gloved hand and the surrounding tissue must be re-established each time the gloved hand is inserted into the body cavity, if insufflation of the body cavity is to be maintained.

[0019] An apparatus and a method for carrying out minimally invasive laparoscopic surgery is also described in U.S. Pat. No. 5,640,977 (Leahy et al). A surgeon's hand is passed through a sleeve to access a body cavity, the sleeve being sealed around the surgeon's forearm.

[0020] U.S. Pat. No. 5,653,705 (de la Torre et al) discloses an envelope, which is said to provide access for an object passing into a body tissue incision, while maintaining insufflation of the body cavity. A first opening in the envelope is sealed around the body tissue incision and a second opening is sealed around an object passed into the envelope.

[0021] Devices for use during surgery which provide access to a surgical site and effect a seal independent of a surgeon's hand are also known. In general devices of this type are positioned predominantly external to a body cavity, and are complex, large and bulky. These devices prove difficult to use because they are cumbersome and/or because of their complexity. For example, a flexible, fluid-tight envelope to provide access for an object passing through a body tissue incision while maintaining insufflation pressure is described in U.S. Pat. No. 5,672,168 (de la Torre et al). This is a complex device including a first opening secured and sealed to the body tissue incision, and a second opening distal from the body tissue incision and sealed to a surgeon's forearm. The device also includes a housing containing a valve element at the body tissue incision.

[0022] An access port device for use during a surgical procedure is described in U.S. Pat. No. 5,803,921 (Bonadio). An object is passed into the device sleeve, the device is sealed around the object at the sleeve opening and the device is also sealed at the body cavity.

[0023] U.S. Pat. No. 5,741,298 (MacLeod) describes a method for performing surgery using a multi-functional access port. The access port has a sealing ring which protects the body wall incision from contamination. A sealing cap or a surgical glove is connected to the sealing ring to maintain insufflation of the body cavity. This surgical method is also restrictive because the surgeon's gloved hand must remain sealed to the sealing ring, if body cavity insufflation is to be maintained.

[0024] A surgical apparatus for use during hand assisted minimally invasive surgery is described in U.S. Pat. No. 5,813,409 (Leahy et al). A sleeve is mounted at one end to a body tissue incision. The sleeve seals to the surgeon's hand to maintain pneumoperitoneum. Surgical instruments may then be passed into the sleeve to a surgeon's hand within, which may then be inserted into the incision. This device is relatively large, requires a multistep process for installation and comes in several parts.

[0025] U.S. Pat. No. 5,906,577 (Beane et al) describes a retractor device for retracting the edges of an incision to form an opening to a body cavity. A flexible sleeve is mounted to the retractor, and an object passed through the device is sealed to maintain insufflation of the body cavity. This device also consists of many component parts that must be assembled carefully.

[0026] WO 98/35615 (Crook) describes a device for performing HALS that consists of a wound-edge retractor to which is attached a sleeve similar to others mentioned above. This device also consists of several component parts and has a complicated installation procedure.

[0027] An access port device for use during hand-assisted laparoscopic surgery is described in JP 10-108868 (Tamai, Shitomura). This device consists of a wound retractor component to which is attached an iris valve. The wound retractor component is made of two rings, an inner ring and

an outer ring joined by a silastic sleeve to provide a retractive force. The device is inserted into an incision and the surgeon's hand is inserted through the device. The iris valve is then closed around the arm to effect a seal to prevent the escape of insufflation gas.

[0028] Generally known devices are difficult to use because they are cumbersome and/or because of their complexity. In addition, tight seals are often not maintained and/or the movement of a surgeons arm is restricted and/or the device may become dislodged from a wound.

[0029] There is therefore a need for a sealing device, which provides effective sealing means to seal an object passing through the device, and which is convenient and easy to use, compact and neat, and may be used repetitively with minimum delay and minimum effort.

#### STATEMENTS OR INVENTION

[0030] According to the invention there is provided a medical device comprising

[0031] a sleeve of defining a lumen;

[0032] the sleeve having a twisted sleeve section defining a reduced lumen section; and

[0033] tensioning means to facilitate axial extension of the twisted sleeve section.

[0034] In a particularly preferred embodiment the sleeve is twisted to provide the twisted sleeve section. Most preferably the sleeve is of pliable material.

[0035] In a preferred embodiment the means to facilitate axial extension of the twisted sleeve section comprises a chamber for a pressuring fluid.

[0036] In this case the chamber may be defined by an outer sleeve section and an inner sleeve section.

[0037] Preferably the outer sleeve section is a substantially cylindrical sleeve section and the inner sleeve section is a twisted sleeve section of the same untwisted diameter as that of the outer sleeve section.

[0038] In a particularly preferred embodiment the sleeve is turned axially back on itself to define the outer sleeve section and the inner sleeve section.

[0039] Preferably the reduced lumen section is of a smaller size than that of an object to be received therein or passed therethrough.

[0040] In a particularly preferred embodiment on engagement of an object in the reduced lumen section and axial movement of the object relative thereto, the sleeve everts so that the twisted inner sleeve section is rolled over outwardly to become an untwisted outer sleeve section and the outer sleeve section is correspondingly rolled over inwardly to become a twisted inner sleeve section.

[0041] Preferably the chamber is fluid impermeable. Ideally the chamber is inflatable.

[0042] Preferably the chamber has an access port for inflation of the chamber.

[0043] In one particularly preferred embodiment the device includes eversion limiting means to axially limit eversion of the sleeve.

[0044] The device may have a first eversion limiting means for location externally of the opening and a second eversion limiting means for location internally of the opening.

[0045] Preferably the or each eversion limiting mean is an O-ring, preferably of a resilient material.

[0046] In one arrangement the or each eversion limiting means is housed in the chamber.

[0047] The or each eversion limiting means may be movable axially in the chamber.

[0048] In another arrangement there are two eversion limiting means and both are independently movable in the chamber.

[0049] In a further arrangement there are two eversion limiting means and a linkage means is provided between them. The linkage means may be of pliable material. Typically the linkage means comprises a linkage sleeve.

[0050] In another embodiment the eversion limiting means comprises first and second eversion limiting means attached at different locations to the sleeve.

[0051] Preferably the first eversion limiting means is attached to one end of the sleeve and the second eversion limiting means is attached at another end of the sleeve.

[0052] In a particularly preferred embodiment the eversion limiting means are movable relative to one another for twisting the sleeve. The eversion limiting means may be rotatable-relative to one another for twisting the sleeve.

[0053] In one embodiment the device includes handle means to facilitate movement of the eversion limiting means relative to one another.

[0054] Preferably the device includes locking means for locking the first eversion limiting means relative to the second eversion limiting means.

[0055] In another embodiment of the invention the tensioning means is a mechanical tensioning means.

[0056] In this case the tensioning means may comprise a spring means.

[0057] Preferably the reduced lumen section is sized to sealingly engage an object passing therethrough.

[0058] In one aspect the device is for use in surgery.

[0059] The device may be a forearm seal for use in carrying out hand assisted laproscopic surgery.

[0060] Alternatively the device is an endoluminal device.

[0061] The device may be an introducer for introducing an instrument into a body through an opening.

[0062] The device may also be an exsanguinator or an envaginator.

[0063] In another aspect the device is a tissue dissector.

[0064] Alternatively the device is a trocar seal.

#### BRIEF DESCRIPTION OF THE DRAWINGS

[0065] The invention will be more clearly understood from the following description thereof given by way of example only with reference to the accompanying drawings, in which:—

- [0066] FIG. 1 is a perspective view of a hand access device according to the invention;
- [0067] FIG. 2 is a cross sectional view of the device of FIG. 1;
- [0068] FIGS. 3 and 4 are a perspective view of the device being inserted into an incision in the abdominal wall;
- [0069] FIGS. 5 to 7 are perspective, partially cross sectional views of a surgeons hand being inserted through the device;
- [0070] FIG. 8 is a distal end view of the device with a hand in place;
- [0071] FIG. 9 is a perspective, partially cross sectional view of the hand access device with a surgeons hand fully inserted;
- [0072] FIG. 10 is a perspective view of the device in an intermediate position on a surgeon's arm;
- [0073] FIG. 11 is a perspective view of a hand access device in position on a surgeon's arm;
- [0074] FIG. 12 is a cross sectional view of the device of FIG. 11 showing the sealing engagement to the surgeon's arm;
- [0075] FIG. 13 is a cross sectional view of the device of FIGS. 1 to 10 in position ready to receive a surgeon's arm;
- [0076] FIG. 14 is a cross sectional view similar to FIG. 13 fully inserted through an incision;
- [0077] FIG. 15—Not used.
- [0078] FIG. 16 is a perspective view of a tube from which the device may be formed;
- [0079] FIG. 17 is a view of the sleeve of FIG. 16 partially folded over;
- [0080] FIG. 18 is a view of the sleeve of FIG. 17 in a twisted configuration;
- [0081] FIG. 19 is a side view of the twisted sleeve;
- [0082] FIGS. 20 and 21 are perspective views illustrating the insertion of an instrument through an access device of the invention;
- [0083] FIGS. 22 to 25 are side views of the device of FIG. 20 illustrating stages of instrument insertion through the device;
- [0084] FIG. 26 is a cross sectional view of an access device with a circular cross sectional instrument in place;
- [0085] FIG. 27 is a cross sectional view of an access device with a non-circular cross sectional instrument in place;
- [0086] FIGS. 28 and 29 are respectively plan and elevational views of a non-twisted sleeve;
- [0087] FIGS. 30 and 31 are respectively plan and elevational views of a twisted sleeve;
- [0088] FIGS. 32 and 33 are respectively plan and elevational views of the twisted sleeve with an object extending through the lumen of the sleeve;
- [0089] FIGS. 34 to 39 are views of the twisting of a tube similar to FIGS. 28 to 33;
- [0090] FIGS. 40 and 41 are a graphical representation of the angle of twist plotted against lumen diameter.
- [0091] FIG. 42 is a perspective view of a twisted tube with an elongate object passing therethrough;
- [0092] FIG. 43 is an end view of the tube of FIG. 42;
- [0093] FIGS. 44 to 50 are various plan and elevational views illustrating the formation and internal pressurising of a thin walled tube;
- [0094] FIGS. 51 to 61 are various plan and elevational views illustrating the formation and internal pressurising of a thin walled twisted tube;
- [0095] FIGS. 62 to 67 are various side cross sectional and end views illustrating the translation of an elongate object through a twisted tube;
- [0096] FIG. 68 is a perspective view of a hand access device with an integral glove;
- [0097] FIG. 69 is a perspective view of the gloved hand access device of FIG. 68, in place;
- [0098] FIG. 70 is a perspective view of another hand access device with adjustable twist;
- [0099] FIG. 71 is a perspective view of rings used in the access device of FIG. 70;
- [0100] FIG. 72 is a plan view of the rings of FIG. 71;
- [0101] FIG. 73 is a cross sectional view of a detail of proximal rings of the device of FIG. 71;
- [0102] FIG. 74 is a perspective view of a detail of a seal between the proximal rings of FIG. 73;
- [0103] FIG. 75 is a cross sectional view of another hand access device with adjustable twist;
- [0104] FIG. 76 is an exploded sectional view of part of the proximal rings of the device of FIG. 75;
- [0105] FIG. 78 is an enlarged cross sectional view of a sealing mechanism between the proximal rings of FIGS. 76 and 77;
- [0106] FIG. 79 is a perspective view of another hand access device of the invention;
- [0107] FIG. 80 is a side, partially cross sectional view of the device of FIG. 79, in use;
- [0108] FIG. 81 is an enlarged cross sectional view of a detail of the device of FIG. 80;
- [0109] FIG. 82 is a cross sectional view of a sleeve used to form another hand access device of the invention;
- [0110] FIG. 83 is a cross sectional view of the device formed from the sleeve of FIG. 82;
- [0111] FIG. 84 is a cross sectional view of the device of FIG. 83, inflated;
- [0112] FIG. 85 is an enlarged view of a detail of the device of FIG. 84;
- [0113] FIG. 86 is a perspective view of another device of the invention;
- [0114] FIG. 87 is a perspective view of the device of FIG. 86 being adjusted;

- [0115] FIG. 88 is a side, partially cross sectional view of the device of FIGS. 86 and 87;
- [0116] FIG. 89 is a view similar to FIG. 88 of the device partially disassembled;
- [0117] FIG. 90 is a view similar to FIG. 88 with the device of FIG. 89 re-assembled;
- [0118] FIGS. 91a and 91b are cross sectional views of two devices;
- [0119] FIG. 92 is a prospective, partially cut-away view of a further hand access device of the invention;
- [0120] FIG. 93 is a perspective, partially cut-away view of another hand access device of the invention;
- [0121] FIG. 94 is a view of the device of FIG. 93, in use;
- [0122] FIG. 95 is a perspective, partially cut-away view of a further hand access device of the invention;
- [0123] FIG. 96 is a view of the device of FIG. 95, in use;
- [0124] FIG. 97 is a perspective, partially cut-away view of a still further hand access device of the invention; and
- [0125] FIG. 98 is a view of the device of FIG. 97, in use;
- [0126] FIG. 101 is a perspective, partially cut-away view of a further kind hand access device;
- [0127] FIG. 102 is a plan view of a device according to the invention;
- [0128] FIG. 103 is an elevational view of the device of FIG. 102;
- [0129] FIG. 104 is a cross sectional elevational view of the device of FIG. 102;
- [0130] FIG. 105 is a perspective view of the device of FIG. 102;
- [0131] FIGS. 106 to 109 are views illustrating the device of FIGS. 102 to 105 with the sleeve in an extended position;
- [0132] FIG. 110 is a plan view of a device according to another aspect of the invention;
- [0133] FIG. 111 is an elevational view of the device of the device of FIG. 110;
- [0134] FIG. 112 is a cross sectional view of the device of FIG. 110;
- [0135] FIG. 113 is a perspective view of the device of FIG. 110;
- [0136] FIGS. 114 to 117 are views illustrating the device of FIGS. 110 to 113 in a compressed condition;
- [0137] FIG. 118 is an exploded perspective view of another device according to the invention;
- [0138] FIG. 119 is an exploded perspective view of the sealing device of FIG. 118 with the sleeve in an extended position;
- [0139] FIG. 120 is a perspective view of the sealing device of FIG. 118;
- [0140] FIG. 121 is a perspective view of the sealing device of FIG. 118 with the sleeve in an extended position;
- [0141] FIG. 122 is a plan view of the sealing device of FIG. 118 with the sleeve in an extended position;
- [0142] FIG. 123 is an elevational view of the sealing device of FIG. 118 with the sleeve in an extended position;
- [0143] FIG. 124 is a perspective cross sectional view of the sealing device of FIG. 118 with the sleeve in an extended position;
- [0144] FIG. 125 is a perspective view of the sealing device of FIG. 118 with the sleeve in an extended position;
- [0145] FIG. 126 is a cross sectional view of another device according to the invention;
- [0146] FIG. 127 is a cross sectional view of the device of FIG. 126 with the sleeve inflated;
- [0147] FIG. 128 is a cross sectional view of another device according to the invention; and
- [0148] FIG. 129 is a cross sectional view of the sealing device of FIG. 128 with the sleeve inflated and with the tubes axially extended.

#### DETAILED DESCRIPTION

[0149] In a first preferred embodiment of the invention and referring in particular to FIGS. 1 to 16, there is illustrated a hand access device 1 according to the invention which in this case, is for use as a seal for sealing a surgeon's forearm 2 on entry through a wound opening 3, for example in an abdominal wall 4.

[0150] Referring in particular to FIGS. 16 to 19 the sealing device 1 comprises a substantially tubular sleeve 5 of pliable gas tight material formed from a tube 10 such as a suitable biocompatible plastics material. The tube 10 is turned axially back on itself to define an outer sleeve section 11 and an inner sleeve section 12. The tube 10 is twisted so that the axially opposite datum indicators 15, 16 are circumferentially spaced-apart as illustrated in FIG. 18.

[0151] The inner and outer sleeve sections 11, 12, define therebetween a seated inflatable chamber 20. The inner sleeve section 12, defines a lumen 25 and, on inflation of the chamber 20, the inner sleeve section 12 sealingly engages an object extending or passing through the lumen 25.

[0152] The hand access device includes an eversion limiting means for the sleeve 5. The eversion limiting means is in this case provided by a first O-ring 30, which is attached to the sleeve 5 and a second O-ring 31, which is attached to an axially spaced-apart location on the sleeve 5. The inner O-ring 30 is of a suitable resilient elastomeric material for bunching of the ring 30 to facilitate ease of insertion into a wound 3 as illustrated in FIGS. 3 and 4.

[0153] As a surgeon inserts his forearm 2 through the lumen 25 of the device 1, the inner sleeve section rolls 12 along with the arm 2 and in turn the outer sleeve section 11 everts. An effective seal is maintained around the surgeon's forearm 2 and the sealed integrity of the body cavity being operated upon is maintained. To facilitate insertion of the surgeon's arm 2 lubrication may be used. In this case the device 1 is pre-twisted, and may be inflated prior to or during use.

[0154] A wound protector section 35 of the sealing device between the rings 30, 31 may be of a plastics sheet material

that has a greater flexibility than that of the main body of the sleeve **5**. In this way, on inflation of the sleeve **5** the protector section **35** stretches to conform closely to the irregular shape of the wound **3** and provide a tight seal to the wound opening **3**. In addition, the inner ring **30** is drawn against the inner wall surrounding the wound **3**, on inflation of the sleeve **5**. The arrangement also facilitates lubricated rotation of the protector section **35** which facilitates insertion of a surgeon's arm **33**.

[0155] The inner O-ring **30** may have a larger diameter than that of the outer O-ring **31** to create a tapering effect. This arrangement promotes a pressure differential which assists insertion of a surgeon's arm **2** acting against the internal abdominal pressure.

[0156] The invention provides a device which allows laparoscopic surgeons insert their hand into the abdominal space during laparoscopic surgery and regain the tactile feedback, three dimensional perspective and general use of the hand as an operative tool as it was in open surgery. The device is easy to insert into a small incision and easy to withdraw from the same incision. The device facilitates ease of movement within the device so that the device is not a hindrance to the performance of the surgery. An effective seal is provided to both the operator's forearm and to the wound edges so as to prevent the escape of gases used to maintain the pneumoperitoneum.

[0157] In addition the device allows the removal of organ specimens from the abdominal cavity through the device for the purpose of either removing them completely from the body or for performing a surgical procedure on them while they are temporarily removed from the body or extracorporealised. It is a further object of the invention to allow the operator to remove the hand from the device and leave the device in place without compromising the pneumoperitoneum.

[0158] The device **1** consists of a double-layer polymeric sleeve **5** through which the operator can extend a hand **2** into the abdomen. The device **1** is held in place in the abdominal incision **3** by an arrangement of rings **30**, **31** which may be attached to the outer layer of the sleeve **5**. The rings **30**, **31** provide an anchorage for the polymeric sleeve **5** when it is in the abdominal incision **3**. A stopcock valve **26** and inflation bulb allow the device to be inflated through an inflation tube **27** leading into the chamber **20** when it is in position in the incision.

[0159] When the device **1** is in its correct position and is inflated the lumen **25** closes and the device seals up against the edges of the incision **3**, thus preventing the escape of gas from the pneumoperitoneum to the exterior either through the device or between the device and the edges of the incision. If the operator's hand is within the sleeve **5** when it is inflated, the lumen **25** will close around the arm **2** and effect a seal such that no gas can escape from the pneumoperitoneum. The operators hand **2** need not be within the device **1** when it is inflated. The operator's hand may be inserted into the abdominal cavity through the device **1** after it has been inflated. This is possible due to the manner in which the device is constructed.

[0160] The device is assembled in such a manner so that it effectively seals around the arm **2** without constricting the arm **2** or preventing movement of the arm. Full rotational, angular and transverse movement for a surgeon's arm is allowed using the device.

[0161] The device **1** is easily inserted into the abdominal incision prior to use. The device **1** sits in the incision **3** without distortion. A hand is readily inserted through the lumen **25** of the device either in its inflated or uninflated state. The device **1** inflates quickly and effects a seal around the operator's arm **2** to facilitate creation of pneumoperitoneum.

[0162] Referring to FIGS. **20** to **27** there is illustrated another access device **40** which is similar to that described above with reference to FIGS. **1** to **19** and like parts are assigned the same reference numerals. In this case the device **40** is used for insertion of an instrument **41**. The instrument **41** may be of any suitable cross section such as circular (FIG. **26**) or square (FIG. **27**). The device **40** operates in exactly the same way to the device **1** as described above.

[0163] The principles which underlie this invention will be more clear from the following description with reference to FIGS. **28** to **67**.

[0164] FIG. **28** depicts a thin walled tube of pliable material. It can be considered as a number of longitudinal elements, typical of which is the element A-B. Clearly there is a lumen passing through the tube, the diameter of which is the diameter of the tube. Rotation of one end of the tube relative to the other end about the axis of the tube causes the tube to twist into the configuration shown in FIG. **30**.

[0165] The element A-B is now inclined to the axis of the tube but still remains a straight element. It is clear that element A-B in FIG. **30** appears longer than element A-B in **28** (it must have stretched). It follows therefore, that a force must be applied to the element to cause this elongation. In the absence of such a force elongation of the element A-B would not occur and the overall length of the tube would reduce (not depicted) in order to accommodate the change in geometry. At angles of twist less than 180° the element will not intersect the axis of the tube, its mid point being the point of closest proximity to the axis. It is the summation of all the elements at their midpoints that defines the minimum diameter of the reduced lumen formed. This diameter can be calculated knowing the original tube diameter and the angle of twist. The profile of the tube takes the form of a waisted, necked or hourglass shape. This profile is not determined by the shape of any individual element or elements but is the effect of a section in the plane of the tube axis taken through all the elements. Before proceeding to the effects of the introduction of an object into the reduced lumen particular notice should be taken of the elements as they appear in the plan view FIG. **29**. All the elements are straight.

[0166] Clearly, if an object of smaller diameter than the reduced lumen were introduced into the reduced lumen the object could pass through with out making contact with the wall of the reduced lumen. It would therefore not be possible for the tube to grip or create a seal to the object. In order to accommodate the introduction of an object of larger size (diameter) it is necessary that each element deform or bend outward thus forming an increased lumen. This can be seen clearly in FIG. **32**. All the elements are now deformed. As before there is an apparent increase in the length of the elements. Also as before, in the absence of a force to elongate the elements the overall length of the tube will reduce to accommodate the change in geometry (FIG. **33**). So it will be understood that the lumen has increased to accommodate the introduced object with out stretching the

material of the tube and that the tube is intimate contact with the introduced object over at least part of its length.

[0167] The application of an axial force to the tube will cause the now deformed elements to try to straighten. Because the elements of the tube do not lie in the plane of the applied axial force there will be a corresponding radially inward force. This tendency toward straightening of the elements will be restricted by the presence of an object in the lumen. Therefore the radially inward component of the applied force will act on the inserted object creating a pressure or gripping force between the tube and the inserted object.

[0168] Referring to FIGS. 34 to 39 consider the hollow cylindrical tube shown in FIG. 35. The wall of the cylinder defines a lumen through its centre. Consider a linear element A-B. If the upper edge of the tube is rotated through some angle, point A will move to the position shown in FIGS. 36 and 37. The element A-B will still define a straight line. The tube will distort into a nominally hour glass shape with a reduced lumen at mid height. The diameter of the lumen at the neck of the tube is dependant on the angle of twist. When the upper edge is rotated through 180° the lumen will close down to zero diameter. At any horizontal plane through a twisted tube the material must be wrinkled and hence under compressive hoop stress. If the height of the tube remains unaltered then the element A-B is a twisted tube, being longer than in a plain tube, must be under tensile axial stress. If the tube is free of axial constraint the overall length of the tube will reduce.

[0169] Angle of Twist Vs. Lumen Diameter

[0170] FIG. 41 shows the lumen diameter (D2) as a proportion of the tube diameter (D1) for angles of twist (E) from 0° to 180°. The lumen diameter (D2) is calculated from:

$$D2=D1 \cos(E/2).$$

[0171] As can be seen, the lumen diameter is independent of the tube length.

[0172] Elongate Object Passed through Twisted Tube

[0173] As can be seen from FIGS. 41, 42 and 43 the angle of twist necessary to collapse the lumen of a tube to the diameter of an elongate object passed therethrough is dependant on the ratio of the tube diameter to the diameter of the elongate object. The angle of twist can be calculated from:

$$E=2\{\cos^{-1}(D2/D1)\}$$

[0174] where E is the angle of twist,

[0175] D1 is the tube diameter, and

[0176] D2 is the diameter of the elongate object.

[0177] Although depicted as of circular profile, a tube of sufficiently compliant material will conform to many non recursive profiles. For such a profile D2 is taken as the smallest diameter which can be inscribed within the profile.

[0178] Twin Walled Pressure Vessel Under Internal Pressure

[0179] Referring to FIGS. 44 to 50 consider a thin walled tube as shown in FIG. 45a. One end of the tube is folded back on itself as shown in FIG. 47 and the free ends conjoined. What is defined is essentially a twin walled tube

(or two coaxial tubes conjoined at their ends) with an enclosed volume between the two walls. One way of extending the thin walled tube in an axial direction is to introduce a pressurised fluid into the enclosed volume. This causes the outer tube to be subject to tensile axial stress and tensile hoop stress. The inner tube will be subject to tensile axial stress and compressive hoop stress. As a result the diameter of the lumen reduces and the lumen collapses into a nominally duck bill configuration but constrained by the outer tube, FIG. 50.

[0180] Greater control of the lumen can be obtained by the introduction of a twist into the tube. The tube shown in FIG. 52 is twisted as shown in FIG. 54. One end of the tube is folded back on itself, as shown in FIG. 56, and the free ends conjoined. This configuration defines two coaxial conical vessels conjoined at their bases and at a common apex. However the common apex is not constrained to remain in this configuration. In reality, the inner and outer tubes are free to behave as individual tubes each with half of the original twist and as such the composite tube can better be defined as two coaxial hour glass tubes as shown in FIG. 59, each containing half the original total twist. As both the inner and outer tubes are necked they each are subject to compressive hoop stresses.

[0181] Next a pressurised fluid is introduced into the enclosed volume. The introduction of the pressurised fluid extends the inner and outer tubes in an axial direction, reducing the lumen diameter. The outer tube is a necked hour glass tube with compressive hoop stresses. The introduction of the pressurised fluid also induces tensile hoop stresses, negating the compressive hoop stresses induced by the twist. Since, to remain in its twisted configuration, the tube must have compressive hoop stresses and since the pressurised fluid overcomes these compressive stresses the tube untwists and takes on a nominally cylindrical configuration, FIG. 61. Since the inner and outer tubes are conjoined, as the outer tube untwists the inner tube twists more in response. Since the outer tube now has no twist the inner tube must have all the twist. If the original total twist were 180° then the lumen would close totally. Additionally, the material defining the inner tube will be central within the diameter of the outer tube. This configuration will for brevity be called a Cyclops.

[0182] Translation of an Elongate Object through a Cyclops

[0183] Consider the arrangement depicted in FIG. 62. A shaft is passed through a Cyclops with the lumen in mutual contact with the shaft. The outer tube of the Cyclops is resting in mutual contact with a fixed surface. Consider points of contact A, between the Cyclops and the fixed surface, and B, between the shaft and the lumen of the Cyclops. As the shaft is translated, as shown in FIG. 64, point A remains fixed whilst the leading end of the lumen rolls out. Since the Cyclops does not change in overall length the trailing end of the outer tube rolls in as depicted. It will be apparent that the shaft translates to the right twice as far as the Cyclops. This is exactly the motion of a caterpillar track. From this point of view a Cyclops could be considered as a three dimensional caterpillar track. Since points A and B on the Cyclops do not move relative to their corresponding positions on the shaft and the fixed surface there is no frictional resistance to the translation of the shaft. In FIG. 66, the Cyclops has translated to the right by

approximately its own length. The material which had originally formed the inner tube has rolled out to become the outer tube and vice versa. In other words the Cyclops has turned inside out. Since the inner tube of the Cyclops is in a twisted configuration and since the point B remains in contact with the same point, the shaft rotates about its axis as depicted by arrow C (in this instance approx. 120°). In order to obtain this translation the resistance required to be overcome is that generated as the leading and trailing ends of the Cyclops deform as they roll out and roll in respectively.

[0184] Referring to FIGS. 68 and 69 there is illustrated another access device 50 which in this case has a glove 51 integral with or attached thereto to receive a surgeon's hand.

[0185] Referring to FIGS. 70 to 74 there is illustrated another hand access device 55 according to the invention. The device 55 is similar to those described above except that in this case the twist is adjustable in situ. In this case the sleeve 5 has an inner ring 56 similar to the ring 30 and an outer ring assembly comprising two interengagable rings 57, 58 which are rotatable relative to one another to adjust the twist in the sleeve 5. The rings 57, 58 are snap fitted together and a seal 60 is used to prevent air egress. The seal 60 has a head part 61 which is housed in a female recess 62 in the ring 57 and a sealing part 62 which extends to sealingly engage a projecting part 63 of the outer ring 58.

[0186] Referring to FIGS. 75 and 78 there is illustrated another adjustable twist device 70 which is similar to the device 55 of FIGS. 70 to 74 and like parts are assigned the same reference numerals. In this case snap projections 79, 80 engage on assembly of the mounting rings 57, 58. To ensure gas tight sealing between the rings 57, 58 an elastomeric sealing ring 81 is provided. The sealing ring 81 is housed in a recess in the male part 82 of the outer mounting ring 59 and projects into the space between the two rings 57, 58, on assembly to engage against an integral projection 92 of the lower ring 58. Mounting ring seals 93, 94 are used for mounting the sleeve 5 to the outer and inner mounting rings 57, 58, respectively.

[0187] In each of the devices 55, 70 the mounting ring 57 includes a side port 95 having a passageway 96 for entry of an inflation gas into the sleeve 5. The mounting rings 57, 58 are rotatable relative to one another to twist the sleeve 5 and so reduce the diameter of the lumen 25 defined by the sleeve 5. The relative rotation is effected by gripping opposed handles 97, 98 on the mounting rings 57, 58 and turning them. This causes the sleeve 5 to twist from a configuration 28 where there is no twist to, for example, a 90° twist or a 180° twist in which the lumen 25 is closed. The sleeve 5 may therefore be pre-twisted or twisted during a surgical procedure.

[0188] In use, the sleeve 5 is untwisted and the O-ring 56 is inserted through a wound opening 3. A surgeon then inserts his hand through the sleeve 5. The rings 57, 58 are relatively rotated to twist the sleeve 5 and so reduce the lumen diameter. The sleeve 5 is then inflated by introducing pressurised gas through the entry port 95. This causes the sleeve 5 to extend in the axial direction, and the diameter of the lumen 25 to reduce, further enhancing the seal. The surgical procedure is then carried out. On completion of the surgical procedure, a combination of deflation and/or untwisting of the sleeve 5 is used to allow a surgeon to

remove his hand. In this way, if required, the gas seal may be maintained as a surgeon removes his hand and when the hand is fully removed.

[0189] One advantage of this sealing device is that it is adjustable on site and in situ to suit a particular patient, surgeon and/or procedure.

[0190] The mounting rings 57, 58 slide over one another as they rotate relative to one another. It is desirable to have a small frictional force acting between the surfaces as they rotate relative to one another to facilitate ease of operation of the device 55, 70 and also to maintain the desired sealing contact between the two rings 57, 58.

[0191] Referring to FIGS. 79 to 81 there is illustrated another surgical device 100 according to the invention. In this case an inner ring 101 has engagement means in the form of a radially and axially extending lip seal 105 to engage an inner wall of a patient at the wound opening. This facilitates positive location and engagement of the device 100, in use.

[0192] Referring to FIGS. 82 to 85, there is illustrated another device 109. In this case an inner liner or bladder 110, extending between the outer and inner rings 111, 112 is provided to ensure that the inflated sleeve 5 interior is maintained sealed while the rings 111, 112 are rotated relative to one another.

[0193] Referring to FIGS. 86 to 88 there is illustrated another surgical device 20 according to the invention. The device 1 comprises a first O-ring 201, a first outer mounting means in the form of an O-ring 202 mounted in a first receiver 203, and a second mounting means in the form of an O-ring 205 mounted in a second receiver 206. The receivers 203, 206 are in this case interconnectable as illustrated and a fourth O-ring 207 is provided between the receivers 203, 206 on assembly.

[0194] A sleeve 210 of flexible pliable plastic material extends from the second outer receiver 206 to the first outer receiver 203. The receivers 203, 206 are de-mountable as illustrated in FIG. 87 to facilitate relative rotation therebetween in the direction of the arrows to vary the degree of twist in the sleeve 210.

[0195] Referring to FIGS. 89 and 90 there is illustrated another surgical device 220 which is similar to the device 200. In this case the O-ring 205 is de-mountable from the receiver 206 to facilitate length adjustment of the sleeve 210. On removal of the O-ring 205 the sleeve 210 is adjusted to a desired length d. In this way a single device 220 may be used for a variety of thickness of abdomens. The lumen diameter defined by the twist does not need to be changed to cater for a range of abdomen sizes. The excess sleeve may be cut off or wound around the O-ring seal 205.

[0196] Referring to FIGS. 91a and 91b there is illustrated an assembly of two surgical devices 250, 260. The device 250 is a forearm seal and the device 260 is a wound protector retractor which is assembled to an outer sealing device 250. The sealing device 250 provides an outer sealed access port through which a surgeon may insert his forearm or for insertion of an instrument or the like.

[0197] Referring to FIG. 92 there is illustrated a modified hand access device 55 according to the invention. In this

case an inner ring **56** is enclosed in a pocket **57** on the sleeve **5** while an outer ring **58** is free to move between the walls of the sleeve.

[0198] Referring to **FIGS. 93 and 94** there is illustrated another hand access device **160** in which eversion limiting rings **61, 62** are free to move axially inside the sleeve **5**. The device is used as described above, the outer ring **61** engaging the outside of the abdominal wall on insertion to limit eversion into the incision. The inner ring **162** is free between the walls of the sleeve **5** when the sleeve is fully everted into the wound as illustrated in **FIG. 94**. On withdrawal of a surgeons arm eversion the sleeve outwardly is limited by engagement of the ring **162** against the inside of the abdominal wall. One advantage of this arrangement is that the same device may be used for a wide range of different thicknesses of abdomen.

[0199] Referring to **FIGS. 95 and 96** there is illustrated another hand access device **165** which is again similar to those described above. In this case inner and outer rings **166, 167** are not attached to the sleeve **5**, however a linking section **168** of pliable material extends between the rings **166, 167**.

[0200] Referring now to **FIGS. 97 and 98** there is illustrated another hand access device **70** according to the invention. In this case an inner ring **71** is held in a desired axial position in the sleeve **5** by adhesive tapes **73**. An outer ring **72** is free to move axially within the sleeve.

[0201] Referring to **FIG. 99** there is illustrated another medical device **700** according to the invention which is similar to those described above and like parts are assigned the same reference numerals. The device includes a shielding device to shield the existing connection between the rings **30, 31**. The shield shields the sleeve section **35** that engages with the incision from the axial tensile force. This facilitates improved conformity to the incision margins and enhanced retraction and sealing.

[0202] In this case the shield is in the form of a film **701** which is of lighter gauge than that of the main sleeve **5**. There is a hole **702** in the main sleeve **5** which allows air access to the chamber **706** between the main sleeve **5** and the film **701**. The hole **702** may be covered by a valve such as a non return flap valve **705**.

[0203] The shielding film **701** is illustrated as deflated in **FIG. 99a**. After inflation it bulges outwardly as illustrated in **FIG. 99b** and a better conformity to the incision is achieved as illustrated in **FIG. 99c**.

[0204] This arrangement may then be used to allow deflation of the inner sleeve for improved access as illustrated in **FIG. 99d**.

[0205] Referring to **FIG. 100**, in this case the shield is provided by a compressible foam like sleeve **750**. The foam may include stiffening means **751** as illustrated in **FIG. 101**. It will be appreciated that the shield may be of any suitable material.

[0206] Referring to **FIGS. 102 to 109** there is illustrated a sealing device **250** according to the invention. The sealing device **250** comprises a tubular sleeve **251** of pliable material mounted at a first end to a first mounting means and mounted at a second end to a second mounting means. The first mounting means is a resilient ring **252**, the second

mounting means is a resilient ring **253**. The sleeve **251** defines a lumen **254**. The rings **252, 253** are rotated relative to one another to cause the sleeve **251** to twist, thereby reducing the diameter of the lumen **254**. The sleeve **251** is illustrated in a twisted, flaccid position in **FIGS. 102 to 105**. The rings **252, 253** are moved away from each other in the axial direction, thereby extending the sleeve **251** and reducing the lumen diameter further, **FIGS. 106 to 109**.

[0207] The sleeve **251** is sealed around an object passing through the lumen **254**;

[0208] (i) by rotating the rings **252, 253** relative to one another, thereby twisting the sleeve **1** and reducing the diameter of the lumen **254**; or

[0209] (ii) by moving the rings **252, 253** away from one another in the axial direction, thereby extending the sleeve **1** and reducing the diameter of the lumen **254**; or

[0210] (iii) by a combination of (i) and (ii).

[0211] Referring to **FIGS. 110 to 117** there is illustrated a sealing device **300** which is similar to the sealing device **250** of **FIGS. 102 to 109** and like parts are assigned the same reference numerals. In this case resilient struts **305** are connected between the first resilient ring and the second resilient ring. As the two rings are moved together, the struts **305** bend outwardly in a buckling manner. This causes the twisted sleeve to take up a flaccid configuration increasing the lumen diameter, **FIGS. 114 to 117**. The material properties of the struts **305** cause them to unbuckle when released. The struts **305** spring back to their straight positions parallel to the sleeve axis, **FIGS. 110 to 113**. The unbuckling of the struts **305** moves the two rings away from each other in the axial direction and extends the sleeve, thereby reducing the lumen diameter. In this case the sleeve is pre-twisted and the resilient rings are constrained by the struts **305** to remain in the twisted position. The resilient rings cannot rotate relative to one another.

[0212] Referring to **FIGS. 118 to 125** there is illustrated another medical device **400** forming a trocar seal. In this case a coiled spring **401** is positioned between two resilient rings **402, 403** with a sleeve **404** therebetween. The upper end of the coiled spring **401** bears against the underside of the first ring **402** and the lower end of the coiled spring **401** bears against the top side of the second ring **403**. The coiled spring **401** and sealing sleeve **404** are enclosed within a housing. The housing comprises a rigid casing having an upper part **407** and a lower part **408** which are separable from one another and a pliable tubular elastomeric sleeve **409** extending therebetween. The elastomeric sleeve **409** is sealed to the casing upper part and the casing lower part so that it joins the upper part and the lower part together. This arrangement facilitates the movement of the coiled spring **401** from a compressed position to an extended position, with the spring **401** remaining enclosed within the housing.

[0213] When the coiled spring **401** is compressed, the two rings **402, 403** move together. This causes the twisted sleeve to take up a flaccid configuration, increasing the lumen diameter. This compresses the elastomeric sleeve so that the upper and lower parts of the casing are adjacent to each other. When the coiled spring **401** is released, it moves to an extended position. This causes the two rings to move away from each other, extending the twisted sleeve and reducing

the lumen diameter. The elastomeric sleeve is extended to a position in which the upper and lower parts of the casing are distal from each other. The device **400** is used for sealing a cannula.

[0214] Referring to **FIGS. 126 and 127** there is illustrated a sealing device **500** according to the invention. In this case a twisted tubular sleeve **501** is mounted at one end to one end of a rigid tube **502** and at the other end to the other end of the rigid tube **502**, with an enclosed volume **503** between the sleeve **501** and the rigid walls of the tube **502**. The sleeve **501** is inflated by passing air through a port **504** in the tube **502** and into the enclosed volume **505**. The inflation of the sleeve **501** extends the sleeve **501** in the axial direction, thereby reducing the lumen diameter.

[0215] Referring to **FIGS. 127 and 128** there is illustrated a sealing device **600** which is similar to the sealing device **500** of **FIGS. 125 and 126**. One end of a twisted tubular sleeve **601** is mounted to a first rigid tube **602**, the other end of the twisted sleeve **501** is mounted to a second rigid tube **603**. The rigid tubes **602**, **603** partially overlap and are movable in an axial direction relative to one another, so that when the sleeve is inflated and extends in the axial direction, the tubes move axially away from one another in a “trombone-type” action, reducing the lumen diameter. The tubes are constrained at the overlapping ends so that they always overlap at least partially.

[0216] Reference is also made to appropriate alternatives and modifications which are outlined in our parallel applications referenced **ATRO1/C**, **ATRO14/C**, **ATRO15/C**, **ATRO16/C**, **ATRO17/C**, the entire contents of which are incorporated herein by reference.

[0217] The invention is not limited to the embodiments hereinbefore described which may be varied in construction and detail.

1. A medical device comprising:—
  - a sleeve of defining a lumen;
  - the sleeve having a twisted sleeve section defining a reduced lumen section; and
  - tensioning means to facilitate axial extension of the twisted sleeve section.
2. A device as claimed in claim 1 wherein the sleeve is twisted to provide the twisted sleeve section.
3. A device as claimed in claim 1 or 2 wherein the sleeve is of pliable material.
4. A device as claimed in claim 1 wherein the means to facilitate axial extension of the twisted sleeve section comprises a chamber for a pressuring fluid.
5. A device as claimed in claim 4 wherein the chamber is defined by an outer sleeve section and an inner sleeve section.
6. A device as claimed in claim 5 wherein the outer sleeve section is a substantially cylindrical sleeve section and the inner sleeve section is a twisted sleeve section of the same untwisted diameter as that of the outer sleeve section.
7. A device as claimed in claim 5 or 6 wherein the sleeve is turned axially back on itself to define the outer sleeve section and the inner sleeve section.
8. A device as claimed in any preceding claim wherein the reduced lumen section is of a smaller size than that of an object to be received therein or passed therethrough.

9. A device as claimed in any of claims 5 to 8 wherein, on engagement of an object in the reduced lumen section and axial movement of the object relative thereto, the sleeve everts so that the twisted inner sleeve section is rolled over outwardly to become an untwisted outer sleeve section and the outer sleeve section is correspondingly rolled over inwardly to become a twisted inner sleeve section.

10. A device as claimed in any of claims 4 to 9 wherein the chamber is fluid impermeable.

11. A device as claimed in any of claims 4 to 10 wherein the chamber is inflatable.

12. A device as claimed in any of claims 4 to 11 wherein the chamber has an access port for inflation of the chamber.

13. A device as claimed in any of claims 5 to 12 including eversion limiting means to axially limit eversion of the sleeve.

14. A device as claimed in claim 13 including a first eversion limiting means for location externally of the opening and a second eversion limiting means for location internally of the opening.

15. A device as claimed in claim 13 or 14 wherein the or each eversion limiting mean is an O-ring.

16. A device as claimed in claim 15 wherein the O-ring is of a resilient material.

17. A device as claimed in any of claims 13 to 16 wherein the or each eversion limiting means is housed in the chamber.

18. A device as claimed in claim 17 wherein the or each eversion limiting means is movable axially in the chamber.

19. A device as claimed in claim 18 wherein there are two eversion limiting means and both are independently movable in the chamber.

20. A device as claimed in claim 18 wherein there are two eversion limiting means and a linkage means is provided between them.

21. A device as claimed in claim 20 wherein the linkage means is of pliable material.

22. A device as claimed in claim 20 or 21 wherein the linkage means comprises a linkage sleeve.

23. A device as claimed in any of claims 13 to 22 wherein the eversion limiting means comprises first and second eversion limiting means attached at different locations to the sleeve.

24. A device as claimed in claim 23 wherein the first eversion limiting means is attached to one end of the sleeve and the second eversion limiting means is attached at another end of the sleeve.

25. A device as claimed in claim 23 or 24 wherein the eversion limiting means are movable relative to one another for twisting the sleeve.

26. A device as claimed in claim 25 wherein the eversion limiting means are rotatable relative to one another for twisting the sleeve.

27. A device as claimed in claim 25 or 26 including handle means to facilitate movement of the eversion limiting means relative to one another.

28. A device as claimed in any of claims 25 to 26 including locking means for locking the first eversion limiting means relative to the second eversion limiting means.

29. A device as claimed in claim 1 wherein the tensioning means is a mechanical tensioning means.

30. A device as claimed in claim 29 wherein the tensioning means comprises a spring means.

**31.** A device as claimed in any preceding claim wherein the reduced lumen section is sized to sealing engage an object passing therethrough.

**32.** A device as claimed in any preceding claim for use in surgery.

**33.** A device as claimed in any preceding claim wherein the device is a forearm seal for use in carrying out hand assisted laproscopic surgery.

**34.** A device as claimed in any of claims 1 to 31 wherein the device is an endoluminal device.

**35.** A device as claimed in any of claims 1 to 31 wherein the device is an introducer for introducing an instrument into a body through an opening.

**36.** A device as claimed in any of claims 1 to 31 wherein the device is an exsanguinator.

**37.** A device as claimed in any of claims 1 to 31 wherein the device is an envaginator.

**38.** A device as claimed in any of claims 1 to 31 wherein the device is a tissue dissector.

**39.** A device as claimed in any of claims 1 to 31 wherein the device is a trocar seal.

**40.** A medical device substantially as hereinbefore described with reference to the accompanying drawings.

\* \* \* \* \*

专利名称(译)	腹腔镜密封进入装置		
公开(公告)号	<a href="#">US20040092795A1</a>	公开(公告)日	2004-05-13
申请号	US10/315233	申请日	2002-12-10
[标]申请(专利权)人(译)	阿特波斯有限公司		
申请(专利权)人(译)	阿特洛波斯有限公司		
当前申请(专利权)人(译)	阿特洛波斯有限公司		
[标]发明人	BONADIO FRANK MCMANUS RONAN BERNARD YOUNG DEREK WILLIAM REID ALAN CUSHIERI ALFRED		
发明人	BONADIO, FRANK MCMANUS, RONAN BERNARD YOUNG, DEREK WILLIAM REID, ALAN CUSHIERI, ALFRED		
IPC分类号	A61B17/02 A61B1/00 A61B1/01 A61B1/012 A61B1/313 A61B1/32 A61B17/00 A61B17/22 A61B17/34 A61B19/00 A61F2/06 A61F2/84 A61M25/01 A61M25/04 A61M29/00 A61M29/02 A61M39/00		
CPC分类号	A61B17/3423 A61B17/3431 A61B17/3462 A61B17/3498 A61B2017/00477 A61B2017/00557 A61B17/ /0293 A61B2017/3435 A61B2017/3482 A61M25/0119 A61M29/02 A61M2025/0062 A61M2025/109 A61B2017/22051		
优先权	19980999 1998-12-01 IE 19990107 1999-02-15 IE 19990108 1999-02-15 IE 19990110 1999-02-15 IE 19990112 1999-02-15 IE 19990416 1999-05-24 IE		
外部链接	<a href="#">Espacenet</a> <a href="#">USPTO</a>		

摘要(译)

一种用于手辅助腹腔镜手术的手动进入装置包括一个基本上管状的可膨胀气密材料套管，该套管具有扭曲的内套管部分和一个外套管部分。该装置具有内部O形环，用于通过腹壁中的伤口开口插入，外部O形环用于位于伤口开口外部。在插入外科医生的手臂时，套管外翻，同时监测到臂的减小的管腔密封和对伤口开口的密封。

