



US00RE40514E

(19) **United States**
(12) **Reissued Patent**
Mastri et al.

(10) **Patent Number:** **US RE40,514 E**
(45) **Date of Reissued Patent:** ***Sep. 23, 2008**

- (54) **SURGICAL STAPLER**
- (75) Inventors: **Dominick L. Mastri**, Bridgeport, CT (US); **Frank J. Viola**, Sandy Hook, CT (US); **Thomas W. Alesi, Jr.**, New Fairfield, CT (US); **Robert J. Geiste**, Milford, CT (US); **Jon Wilson**, Fairfield, CT (US)
- (73) Assignee: **United States Surgical Corporation**, Norwalk, CT (US)

4,027,510 A	6/1977	Hiltebrandt
4,086,926 A	5/1978	Green et al.
4,244,372 A	1/1981	Kapitanov et al.
4,429,695 A	2/1984	Green
4,505,414 A	3/1985	Filipi
4,589,413 A	5/1986	Malyshev et al.
4,602,634 A	7/1986	Barkley
4,608,981 A	9/1986	Rothfuss et al.
4,610,383 A	9/1986	Rothfuss et al.
4,633,861 A	1/1987	Chow et al.

(Continued)

(*) Notice: This patent is subject to a terminal disclaimer.

FOREIGN PATENT DOCUMENTS

- (21) Appl. No.: **11/311,887**
- (22) Filed: **Dec. 19, 2005**

AU	5476586	9/1986
DE	2744824	4/1978
DE	2903159	1/1980
DE	3114135	10/1982
DE	4213426	10/1992
DE	4300307	7/1994
EP	0041022	12/1981
EP	0136950	4/1985
EP	0140552	5/1985
EP	0156774	10/1985
EP	0216532	4/1987
EP	0220029	4/1987
EP	0213817	11/1987

Related U.S. Patent Documents

Reissue of:

- (64) Patent No.: **6,032,849**
- Issued: **Mar. 7, 2000**
- Appl. No.: **09/119,543**
- Filed: **Jul. 20, 1998**

U.S. Applications:

- (63) Continuation of application No. 08/546,253, filed on Oct. 20, 1995, now Pat. No. 5,782,396, which is a continuation-in-part of application No. 08/520,202, filed on Aug. 28, 1995, now Pat. No. 5,762,256.

(Continued)

Primary Examiner—Scott A. Smith

- (51) **Int. Cl.**
A61B 17/068 (2006.01)
- (52) **U.S. Cl.** **227/176.1; 227/19; 227/178.1**
- (58) **Field of Classification Search** **227/175.1, 227/176.1, 178.1, 179.1, 19, 180.1**
See application file for complete search history.

(57) **ABSTRACT**

A surgical device is described herein that can be used to fire different types and sizes of disposable loading units. In a preferred embodiment, the device applies parallel rows of surgical fasteners to body tissue and concomitantly forms an incision between the rows of staples during an endoscopic or laparoscopic surgical procedure. The device can be utilized with disposable loading units configured to apply linear rows of staples measuring from about 15 mm in length to about 60 mm in length and can be used to fire disposable loading units containing surgical clips and individual staples.

(56) **References Cited**

U.S. PATENT DOCUMENTS

3,079,606 A	3/1963	Bobrov et al.
3,490,675 A	1/1970	Green et al.
3,777,538 A	12/1973	Weatherly et al.

19 Claims, 38 Drawing Sheets

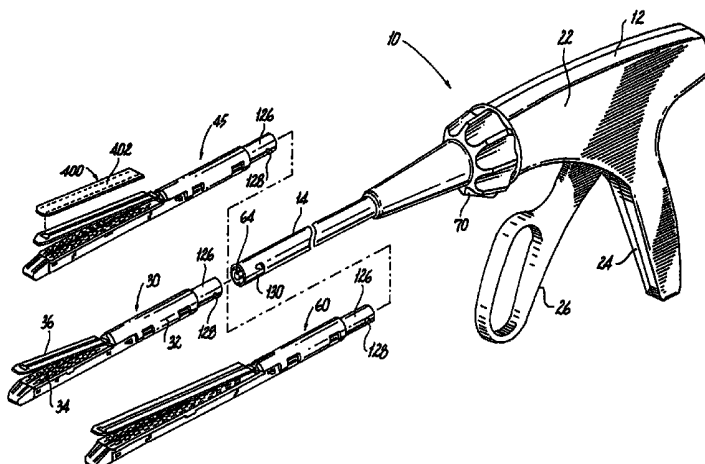

US RE40,514 E

Page 2

U.S. PATENT DOCUMENTS		
4,633,874 A	1/1987	Chow et al.
4,671,445 A	6/1987	Barker et al.
4,703,887 A	11/1987	Clanton et al.
4,728,020 A	3/1988	Green et al.
4,752,024 A	6/1988	Green et al.
4,784,137 A	11/1988	Kulik et al.
4,863,088 A	9/1989	Redmond et al.
4,892,244 A	1/1990	Fox et al.
4,978,049 A	12/1990	Green
4,991,764 A	2/1991	Mericle
5,034,519 A	7/1991	Fox et al.
5,040,715 A	8/1991	Green et al.
5,065,929 A	11/1991	Schulze et al.
5,074,454 A	12/1991	Peters
5,083,695 A	1/1992	Foslien et al.
5,084,057 A	1/1992	Green et al.
5,111,987 A	5/1992	Moeinzadeh et al.
5,129,570 A	7/1992	Schulze et al.
5,141,144 A	8/1992	Foslien et al.
5,170,925 A	12/1992	Madden et al.
5,171,247 A	12/1992	Hughett et al.
5,246,156 A	9/1993	Rothfuss et al.
RE34,519 E	1/1994	Fox et al.
5,282,807 A	2/1994	Knoepfler
5,307,976 A	5/1994	Olson et al.
5,312,023 A	5/1994	Green et al.
5,318,221 A	6/1994	Green et al.
5,326,013 A	7/1994	Green et al.
5,328,077 A	7/1994	Lori
5,332,142 A	7/1994	Robinson et al.
5,336,232 A	8/1994	Green et al.
5,358,506 A	10/1994	Green et al.
5,364,002 A	11/1994	Green et al.
5,364,003 A	11/1994	Williamson, IV
5,376,095 A	12/1994	Ortiz
5,381,943 A	1/1995	Allen et al.
5,382,255 A	1/1995	Castro et al.
5,383,880 A	1/1995	Hooven
5,395,033 A	3/1995	Byrne et al.
5,395,034 A	3/1995	Allen et al.
5,397,046 A	3/1995	Savage et al.
5,397,324 A	3/1995	Carroll et al.
5,407,293 A	4/1995	Crainich
5,413,268 A	5/1995	Green et al.
5,415,334 A	5/1995	Williamson, IV et al.
5,415,335 A	5/1995	Knodell, Jr.
5,417,361 A	5/1995	Williamson, IV
5,423,471 A	6/1995	Mastri et al.
5,425,745 A	6/1995	Green et al.
5,431,322 A	7/1995	Green et al.
5,431,323 A	7/1995	Smith et al.
5,433,721 A	7/1995	Hooven et al.
5,447,265 A	9/1995	Vidal et al.
5,452,837 A	9/1995	Williamson, IV et al.
5,456,401 A	10/1995	Green et al.
5,464,300 A	11/1995	Crainich
5,465,895 A	11/1995	Knodel et al.
5,467,911 A	11/1995	Tsuruta et al.
5,470,007 A	11/1995	Plyley et al.
5,470,010 A	11/1995	Rothfuss et al.
5,472,132 A	12/1995	Savage et al.
5,474,566 A	12/1995	Alesi et al.
5,476,206 A	12/1995	Green et al.
5,478,003 A	12/1995	Green et al.
5,480,089 A	1/1996	Blewett
5,482,197 A	1/1996	Green et al.
5,484,095 A	1/1996	Green et al.
5,484,451 A	1/1996	Akopov et al.
5,485,947 A	1/1996	Olson et al.
5,485,952 A	1/1996	Fontayne
5,486,185 A	1/1996	Freitas et al.
5,487,499 A	1/1996	Sorrentino et al.
5,487,500 A	1/1996	Knodel et al.
5,489,058 A	2/1996	Plyley et al.
5,497,933 A	3/1996	DeFonzo et al.
5,505,363 A	4/1996	Green et al.
5,507,426 A	4/1996	Young et al.
5,518,163 A	5/1996	Hooven
5,518,164 A	5/1996	Hooven
5,529,235 A	6/1996	Boiarski et al.
5,531,744 A	7/1996	Nardella et al.
5,535,934 A	7/1996	Boiarski et al.
5,535,935 A	7/1996	Vidal et al.
5,535,937 A	7/1996	Boiarski et al.
5,540,375 A	7/1996	Bolanos et al.
5,551,622 A	9/1996	Yoon
5,553,765 A	9/1996	Knodel et al.
5,554,164 A	9/1996	Wilson et al.
5,554,169 A	9/1996	Green et al.
5,560,530 A	10/1996	Bolanos et al.
5,560,532 A	10/1996	DeFonzo et al.
5,562,239 A	10/1996	Boiarski et al.
5,562,241 A	10/1996	Knodel et al.
5,562,682 A	10/1996	Oberlin et al.
5,564,615 A	10/1996	Bishop et al.
5,571,116 A	11/1996	Bolanos et al.
5,573,543 A	11/1996	Akopov et al.
5,575,799 A	11/1996	Bolanos et al.
5,577,654 A	11/1996	Bishop
5,579,107 A	11/1996	Wright et al.
5,584,425 A	12/1996	Savage et al.
5,586,711 A	12/1996	Plyley et al.
5,588,580 A	12/1996	Paul et al.
5,588,581 A	12/1996	Conlon et al.
5,597,107 A	1/1997	Knodel et al.
5,601,224 A	2/1997	Bishop et al.
5,607,095 A	3/1997	Smith et al.
5,615,820 A	4/1997	Viola
5,618,291 A	4/1997	Thompson et al.
5,624,452 A	4/1997	Yates
5,626,587 A	5/1997	Bishop et al.
5,628,446 A	5/1997	Geiste et al.
5,630,539 A	5/1997	Plyley et al.
5,630,540 A	5/1997	Blewett
5,630,541 A	5/1997	Williamson, IV et al.
5,632,432 A	5/1997	Schulze et al.
5,634,584 A	6/1997	Okorocho et al.
5,636,780 A	6/1997	Green et al.
5,645,209 A	7/1997	Green et al.
5,647,526 A	7/1997	Green et al.
5,653,374 A	8/1997	Young et al.
5,653,721 A	8/1997	Knodel et al.
5,655,698 A	8/1997	Yoon
5,657,921 A	8/1997	Young et al.
5,658,300 A	8/1997	Bito et al.
5,662,258 A	9/1997	Knodel et al.
5,662,259 A	9/1997	Yoon
5,662,260 A	9/1997	Yoon
5,662,662 A	9/1997	Bishop et al.
5,662,666 A	9/1997	Onuki et al.
5,667,517 A	9/1997	Hooven
5,669,544 A	9/1997	Schulze et al.
5,673,840 A	10/1997	Schulze et al.
5,673,841 A	10/1997	Schulze et al.
5,673,842 A	10/1997	Bittner et al.
5,676,674 A	10/1997	Bolanos et al.
5,680,981 A	10/1997	Mililli et al.
5,680,982 A	10/1997	Schulze et al.
5,690,269 A	11/1997	Bolanos et al.
5,692,668 A	12/1997	Schulze et al.
5,697,542 A	12/1997	Knodel et al.

US RE40,514 E

Page 3

5,704,534 A	1/1998	Huitema et al.	6,505,768 B2	1/2003	Whitman
5,706,997 A	1/1998	Green et al.	6,544,274 B2	4/2003	Danitz et al.
5,709,334 A	1/1998	Sorrentino et al.	6,554,844 B2	4/2003	Lee et al.
5,711,472 A	1/1998	Bryan	6,565,554 B1	5/2003	Niemeyer
5,713,505 A	2/1998	Huitema	6,587,750 B2	7/2003	Gerbi et al.
5,716,366 A	2/1998	Yates	6,592,597 B2	7/2003	Grant et al.
5,725,536 A	3/1998	Oberlin et al.	6,594,552 B1	7/2003	Gerbi et al.
5,725,554 A	3/1998	Simon et al.	6,602,252 B2	8/2003	Mollenauer
5,728,110 A	3/1998	Vidal et al.	6,612,053 B2	9/2003	Liao
5,735,848 A	4/1998	Yates et al.	6,619,529 B2	9/2003	Green et al.
5,743,456 A	4/1998	Jones et al.	6,644,532 B2	11/2003	Green et al.
5,749,893 A	5/1998	Vidal et al.	6,656,193 B2	12/2003	Grant et al.
5,752,644 A	5/1998	Bolanos et al.	6,669,073 B2	12/2003	Milliman et al.
5,762,255 A	6/1998	Chrisman et al.	6,698,643 B2	3/2004	Whitman
5,762,256 A	6/1998	Mastri et al.	6,716,232 B1	4/2004	Vidal et al.
5,769,303 A	6/1998	Knodel et al.	6,722,552 B2	4/2004	Fenton, Jr.
5,772,673 A	6/1998	Cuny et al.	6,731,473 B2	5/2004	Li et al.
5,779,130 A	7/1998	Alesi et al.	6,755,338 B2	6/2004	Hahnen et al.
5,779,131 A	7/1998	Knodel et al.	6,783,524 B2	8/2004	Anderson et al.
5,779,132 A	7/1998	Knodel et al.	6,786,382 B1	9/2004	Hoffman
5,782,396 A	7/1998	Mastri et al.	6,808,262 B2	10/2004	Chapoy et al.
5,782,397 A	7/1998	Koukline	6,830,174 B2	12/2004	Hillstead et al.
5,782,834 A	7/1998	Lucey et al.	6,835,199 B2	12/2004	McGuckin, Jr. et al.
5,797,536 A	8/1998	Smith et al.	6,843,403 B2	1/2005	Whitman
5,797,537 A	8/1998	Oberlin et al.	RE38,708 E	3/2005	Bolanos et al.
5,797,538 A	8/1998	Heaton et al.	6,877,647 B2	4/2005	Ratcliff
5,810,811 A	9/1998	Yates et al.	6,879,880 B2	4/2005	Nowlin et al.
5,810,855 A	9/1998	Rayburn et al.	6,889,116 B2	5/2005	Jinno
5,814,055 A	9/1998	Knodel et al.	6,905,057 B2	6/2005	Swayze et al.
5,816,471 A	10/1998	Plyley et al.	6,953,138 B1	10/2005	Dworak et al.
5,817,109 A	10/1998	McGarry et al.	6,953,139 B2	10/2005	Milliman et al.
5,820,009 A	10/1998	Melling et al.	6,959,852 B2	11/2005	Shelton, IV et al.
5,823,066 A	10/1998	Huitema et al.	6,964,363 B2	11/2005	Wales et al.
5,826,776 A	10/1998	Schulze et al.	6,978,921 B2	12/2005	Shelton, IV et al.
5,829,662 A	11/1998	Allen et al.	6,981,628 B2	1/2006	Wales
5,833,695 A	11/1998	Yoon	6,986,451 B1	1/2006	Mastri et al.
5,836,147 A	11/1998	Schnipke	6,988,649 B2	1/2006	Shelton, IV et al.
5,862,972 A	1/1999	Green et al.	7,000,818 B2	2/2006	Shelton, IV et al.
5,865,361 A	2/1999	Milliman et al.	7,000,819 B2	2/2006	Swayze et al.
5,871,135 A	2/1999	Williamson, IV et al.	2002/0004498 A1	1/2002	Doherty
5,873,873 A	2/1999	Smith et al.	2002/0009193 A1	1/2002	Deguchi
5,897,562 A	4/1999	Bolanos et al.	2002/0018323 A1	2/2002	Li
5,901,895 A	5/1999	Heaton et al.	2002/0032948 A1	3/2002	Ahn
5,911,353 A	6/1999	Bolanos et al.	2002/0084304 A1	7/2002	Whitman
5,918,791 A	7/1999	Sorrentino et al.	2002/0111621 A1	8/2002	Wallace et al.
5,919,198 A	7/1999	Graves, Jr. et al.	2002/0143346 A1	10/2002	McGuckin, Jr. et al.
5,922,001 A	7/1999	Yoon	2002/0177843 A1	11/2002	Anderson et al.
5,954,259 A	9/1999	Viola et al.	2002/0188294 A1	12/2002	Couture
5,980,510 A	11/1999	Tsontou et al.	2002/0190093 A1	12/2002	Fenton, Jr.
6,004,335 A	12/1999	Vaitekunas et al.	2003/0009193 A1	1/2003	Corsaro
6,010,054 A	1/2000	Johnson et al.	2003/0105476 A1	6/2003	Sancoff et al.
6,032,849 A	3/2000	Mastri et al.	2003/0132268 A1	7/2003	Whitman
6,079,606 A	6/2000	Milliman et al.	2004/0004105 A1	1/2004	Jankowski
6,109,500 A	8/2000	Alli et al.	2004/0007608 A1	1/2004	Ehrenfels
6,197,017 B1	3/2001	Brock et al.	2004/0050902 A1	3/2004	Green
6,202,914 B1	3/2001	Geiste et al.	2004/0093029 A1	5/2004	Zubik et al.
6,241,139 B1	6/2001	Milliman et al.	2004/0094597 A1	5/2004	Whitman
6,250,532 B1	6/2001	Green et al.	2004/0108357 A1	6/2004	Milliman
6,264,086 B1	7/2001	McGuckin, Jr.	2004/0149802 A1	8/2004	Whitman
6,264,087 B1	7/2001	Whitman	2004/0173659 A1	9/2004	Green
6,279,809 B1	8/2001	Nicolo	2004/0199181 A1	10/2004	Knodel et al.
6,315,183 B1	11/2001	Piraka	2004/0232199 A1	11/2004	Shelton, IV et al.
6,315,184 B1	11/2001	Whitman	2004/0232200 A1	11/2004	Shelton, IV et al.
6,325,810 B1	12/2001	Hamilton et al.	2004/0232201 A1	11/2004	Wenchell
6,330,965 B1	12/2001	Milliman et al.	2004/0243151 A1	12/2004	Demmy
6,436,097 B1	8/2002	Nardella	2004/0267310 A1	12/2004	Racenet
6,439,446 B1	8/2002	Perry et al.	2005/0006429 A1	1/2005	Wales
6,443,973 B1	9/2002	Whitman	2005/0006430 A1	1/2005	Wales
6,463,623 B2	10/2002	Ahn et al.	2005/0006431 A1	1/2005	Shelton, IV et al.
6,488,196 B1	12/2002	Fenton, Jr.	2005/0006432 A1	1/2005	Racenet
6,503,257 B2	1/2003	Grant et al.	2005/0006433 A1	1/2005	Millman

US RE40,514 E

Page 4

2005/0006434	A1	1/2005	Wales et al.	EP	0503662	9/1992
2005/0023324	A1	2/2005	Doll et al.	EP	0514139	11/1992
2005/0023325	A1	2/2005	Gresham	EP	0536903	4/1993
2005/0067457	A1	3/2005	Shelton	EP	0537572	4/1993
2005/0067458	A1	3/2005	Swayze et al.	EP	0539762	5/1993
2005/0067459	A1	3/2005	Swayze et al.	EP	0545029	6/1993
2005/0067460	A1	3/2005	Milliman	EP	0552050	7/1993
2005/0072827	A1	4/2005	Mollenauer	EP	0552423	7/1993
2005/0103819	A1	5/2005	Racenet	EP	0579038	1/1994
2005/0119669	A1	6/2005	Demmy	EP	0589306	3/1994
2005/0127131	A1	6/2005	Mastri	EP	0591946	4/1994
2005/0165415	A1	7/2005	Wales	EP	0592243	4/1994
2005/0173490	A1	8/2005	Shelton, IV	EP	0593920	4/1994
2005/0178813	A1	8/2005	Swayze et al.	EP	0598202	5/1994
2005/0184123	A1	8/2005	Scirica et al.	EP	0598579	5/1994
2005/0184124	A1	8/2005	Scirica et al.	EP	0621006	10/1994
2005/0184125	A1	8/2005	Marczyk	EP	0621009	10/1994
2005/0184126	A1	8/2005	Green et al.	EP	0656188	6/1995
2005/0189397	A1	9/2005	Jankowski	EP	0365153	8/1995
2005/0216055	A1	9/2005	Scirica et al.	EP	0666057	8/1995
2005/0263562	A1	12/2005	Shelton, IV et al.	EP	0705571	4/1996
2005/0279804	A1	12/2005	Scirica et al.	FR	2542188	9/1984
2006/0000867	A1	1/2006	Shelton, IV et al.	FR	2660851	10/1991
2006/0000868	A1	1/2006	Shelton, IV et al.	FR	2681775	10/1991
2006/0011699	A1	1/2006	Olson et al.	GB	1352554	4/1971
2006/0016853	A1	1/2006	Racenet	GB	1452185	10/1976
2006/0022014	A1	2/2006	Shelton, IV et al.	GB	1555455	11/1979
2006/0022015	A1	2/2006	Shelton, IV et al.	GB	2048685	12/1980

FOREIGN PATENT DOCUMENTS

EP	0273468	7/1988	GB	2070499	9/1981
EP	0324166	7/1989	GB	2141066	12/1984
EP	0324635	7/1989	GB	216559	4/1986
EP	0324637	7/1989	JP	51-149985	5/1975
EP	0324638	7/1989	RU	0119846	1/1959
EP	0369324	5/1990	RU	980703	12/1982
EP	0373762	6/1990	RU	990220	1/1983
EP	0380025	8/1990	SU	728848	5/1977
EP	0399701	11/1990	SU	659146	4/1979
EP	0449394	10/1991	WO	WO 89/10094	11/1989
EP	0484677	5/1992	WO	WO9210976	7/1992
EP	0489436	6/1992	WO	9308754	5/1993
			WO	WO8302247	7/1993
			WO	9314706	8/1993

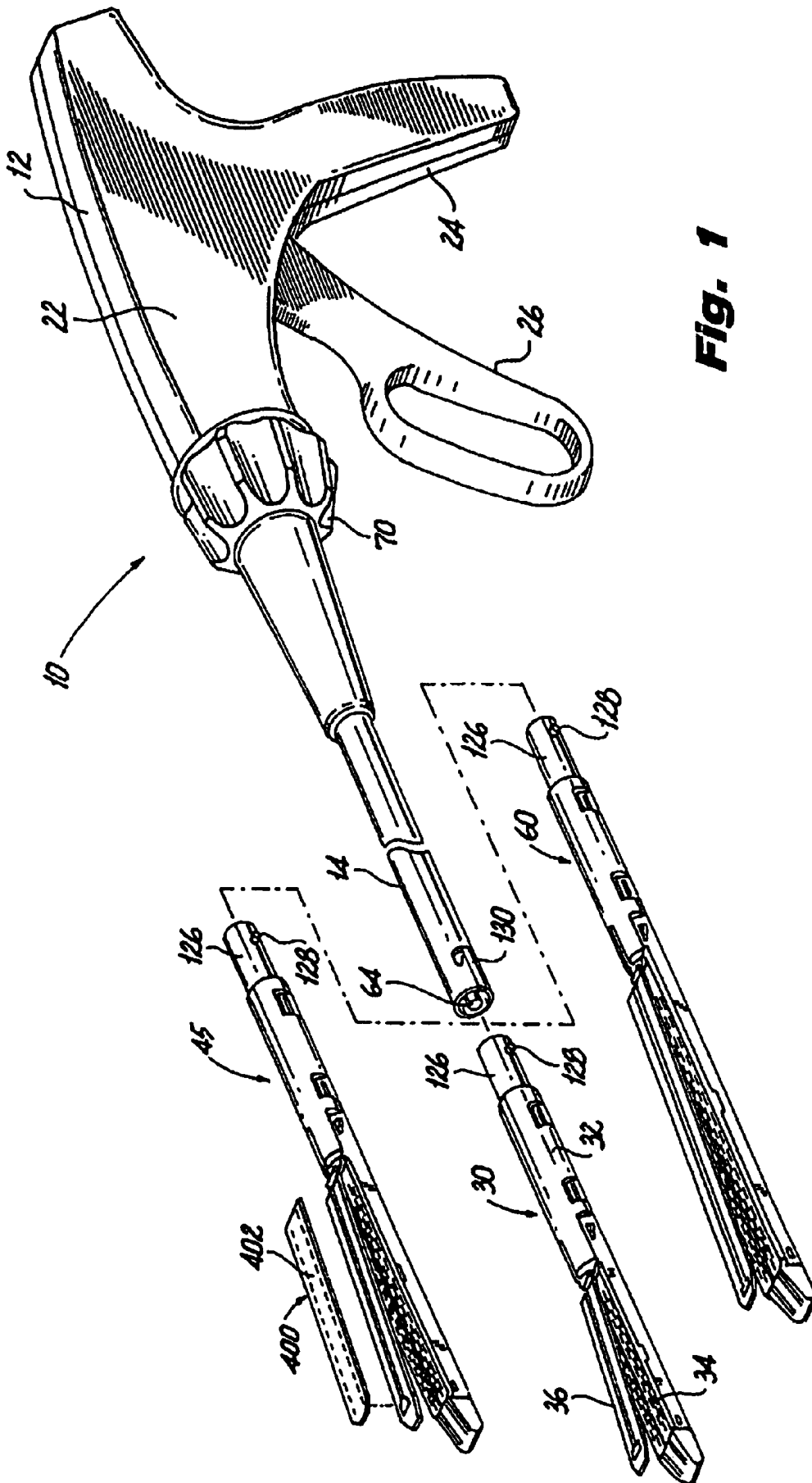
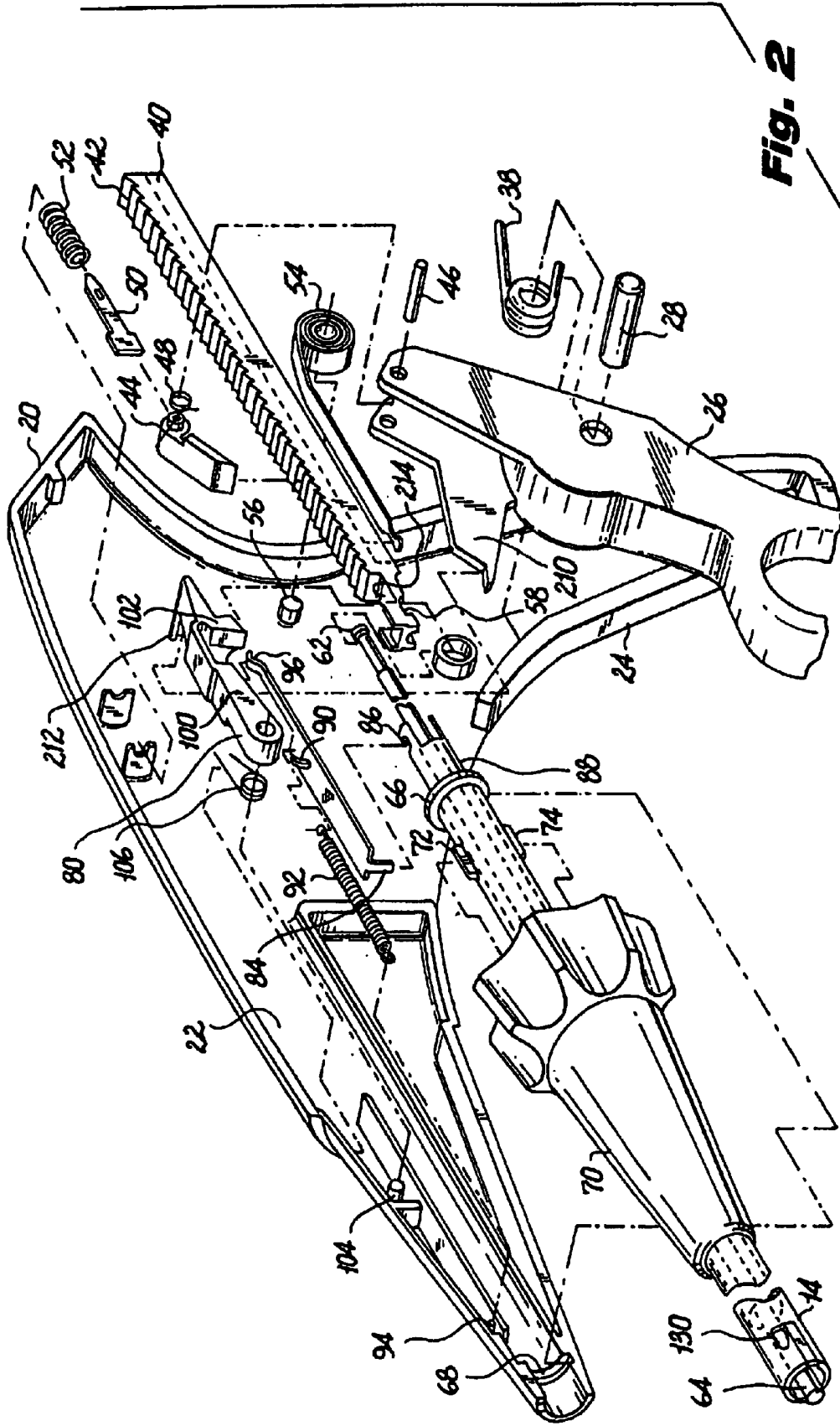

Fig. 1



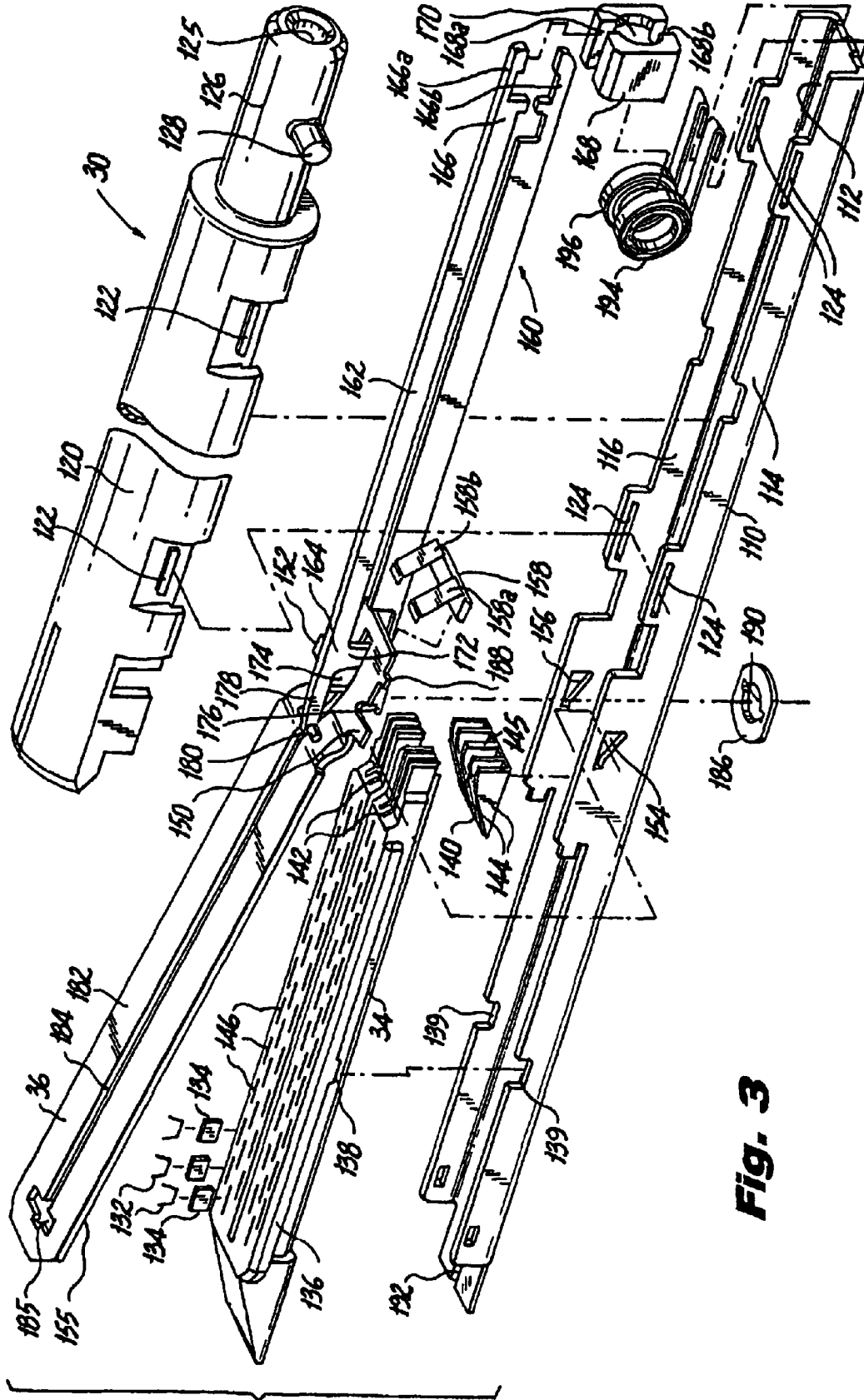

Fig. 3

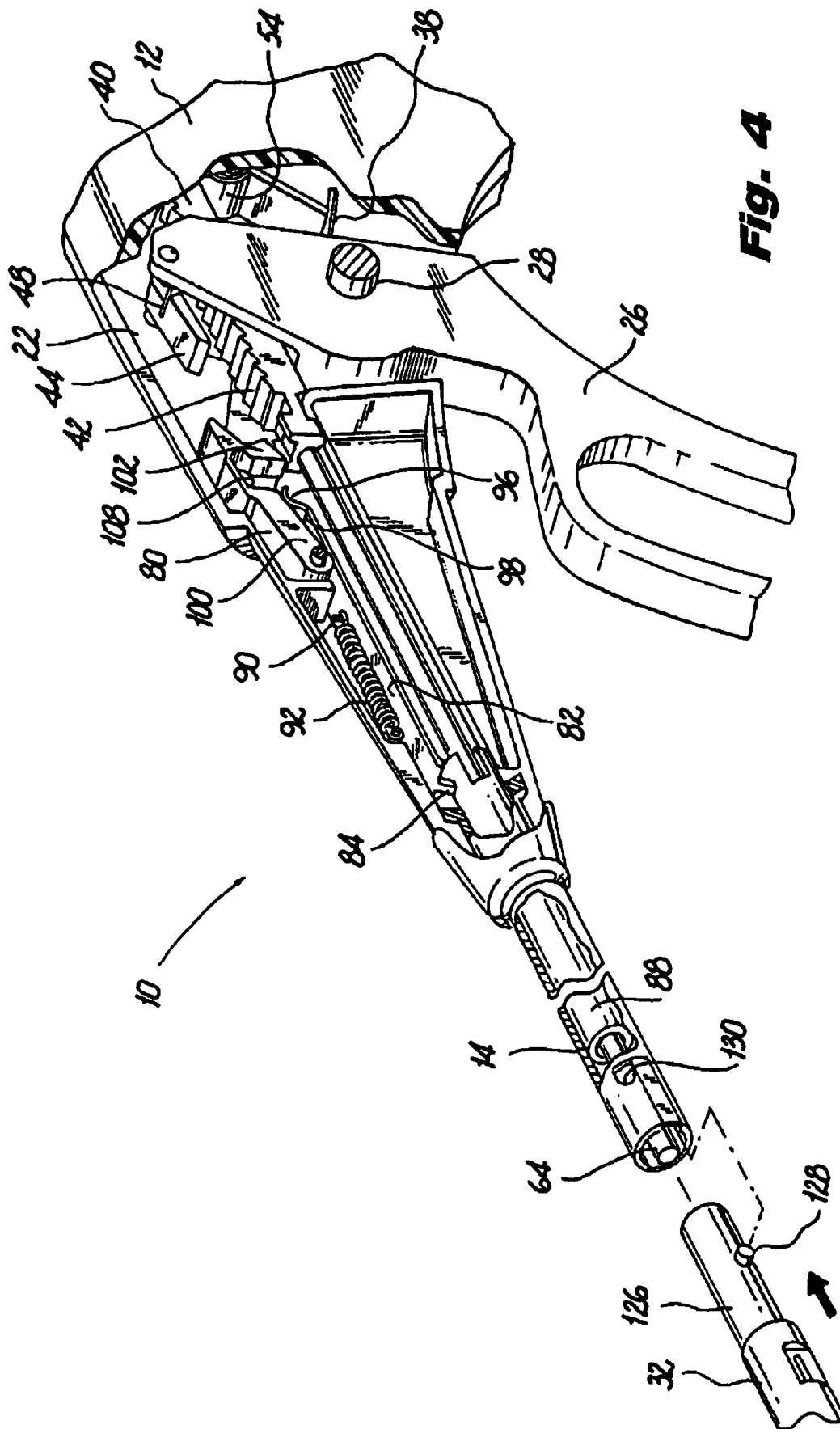

Fig. 4

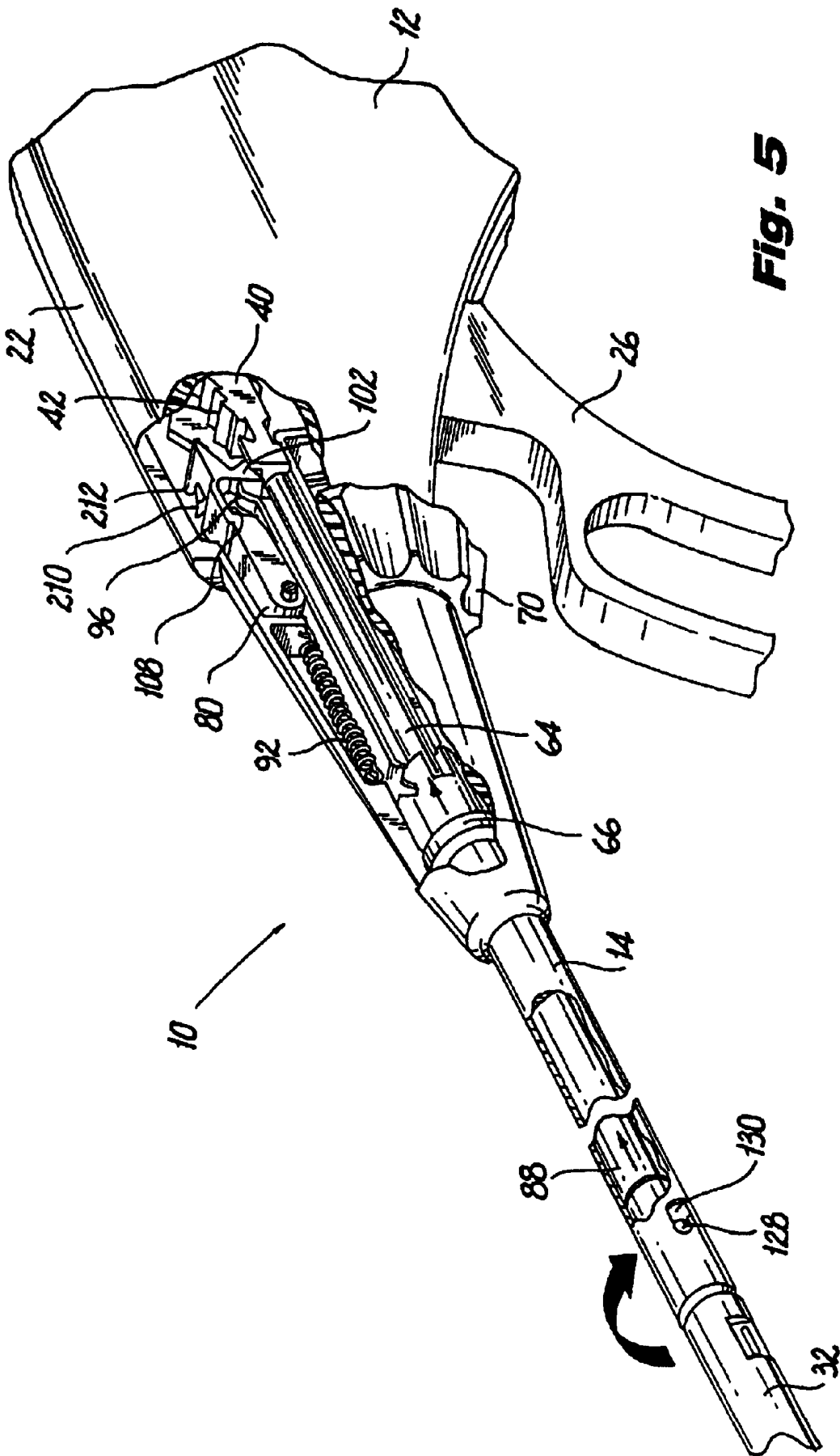

Fig. 5

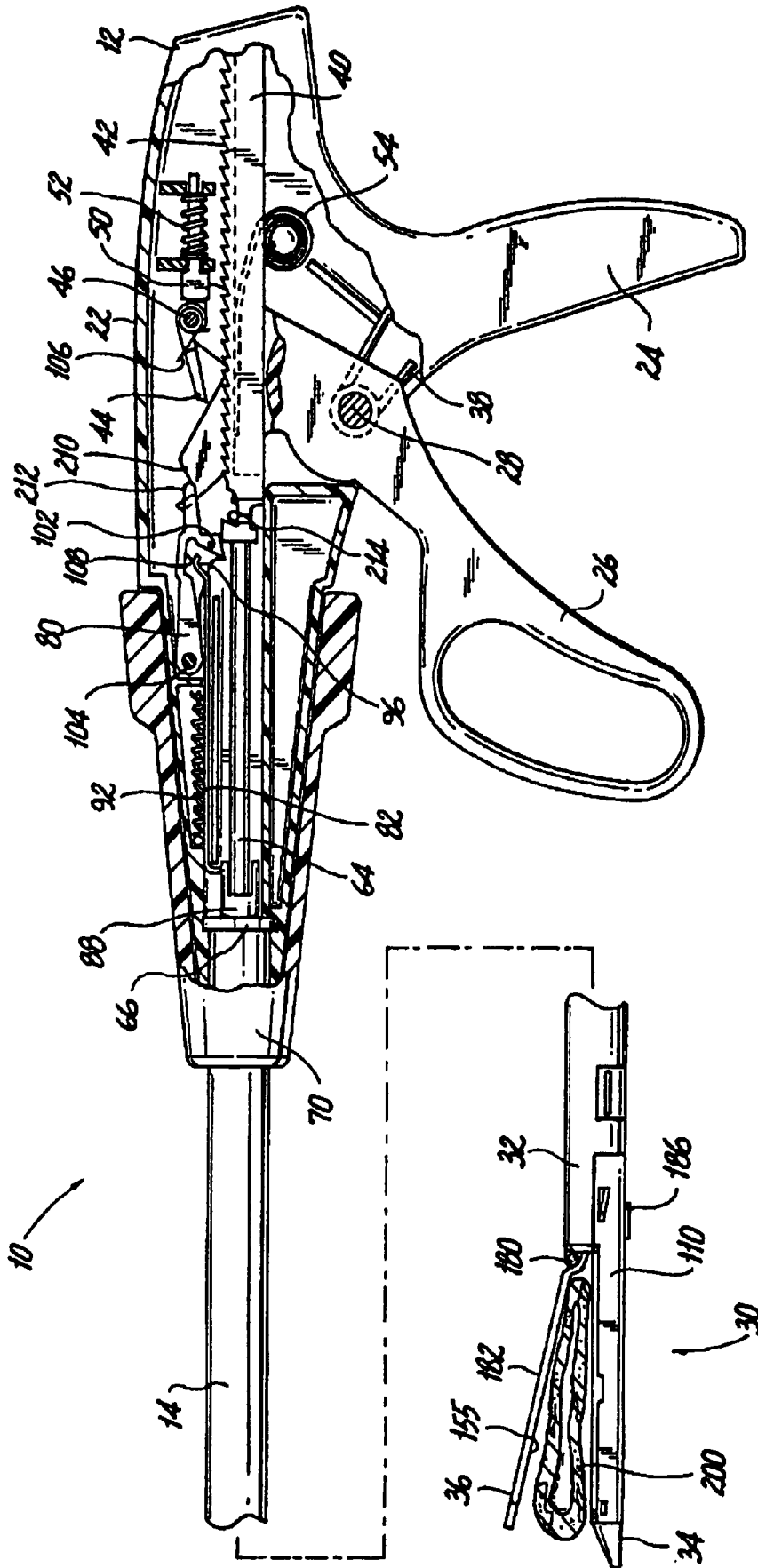
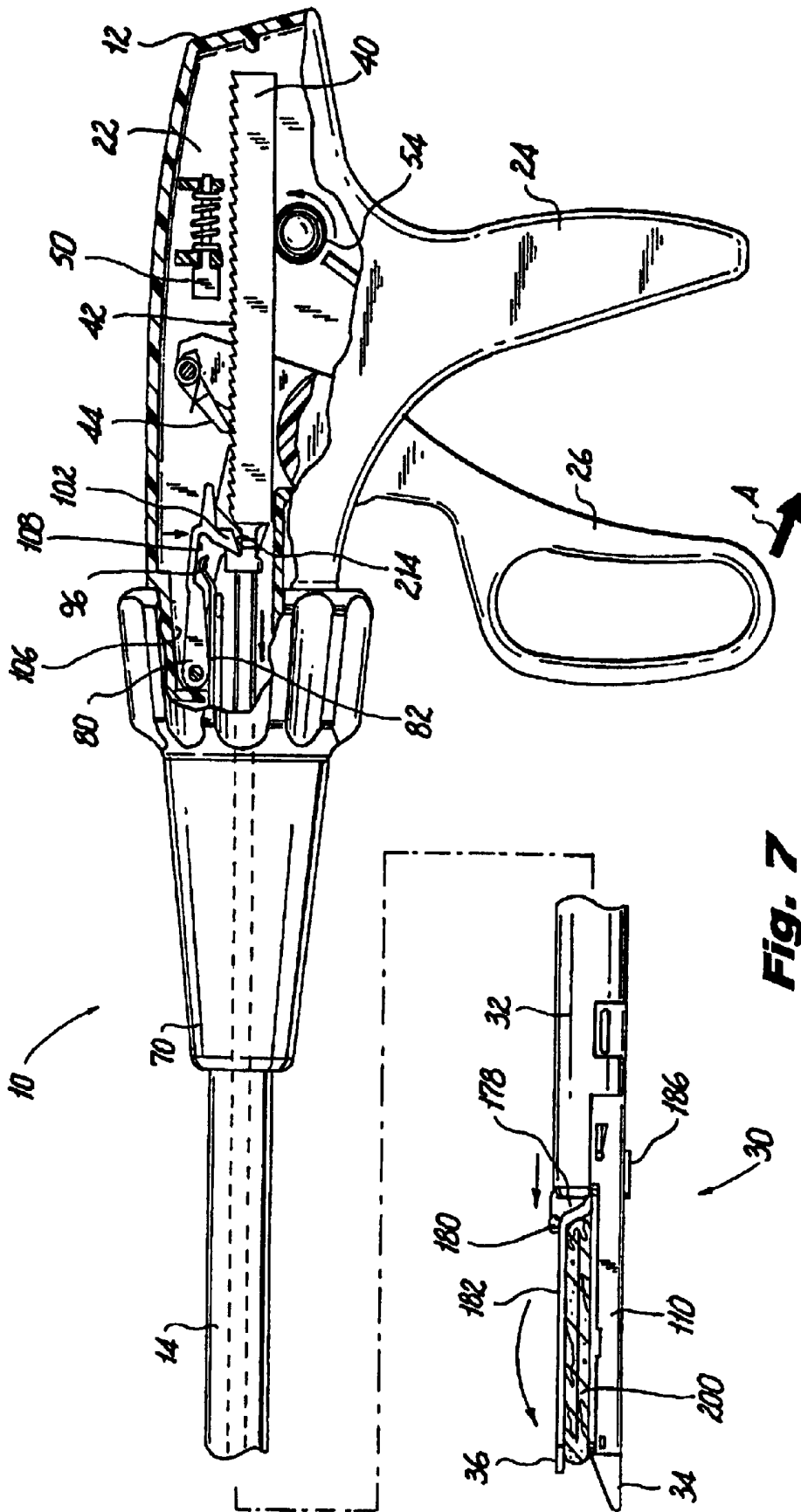

Fig. 6



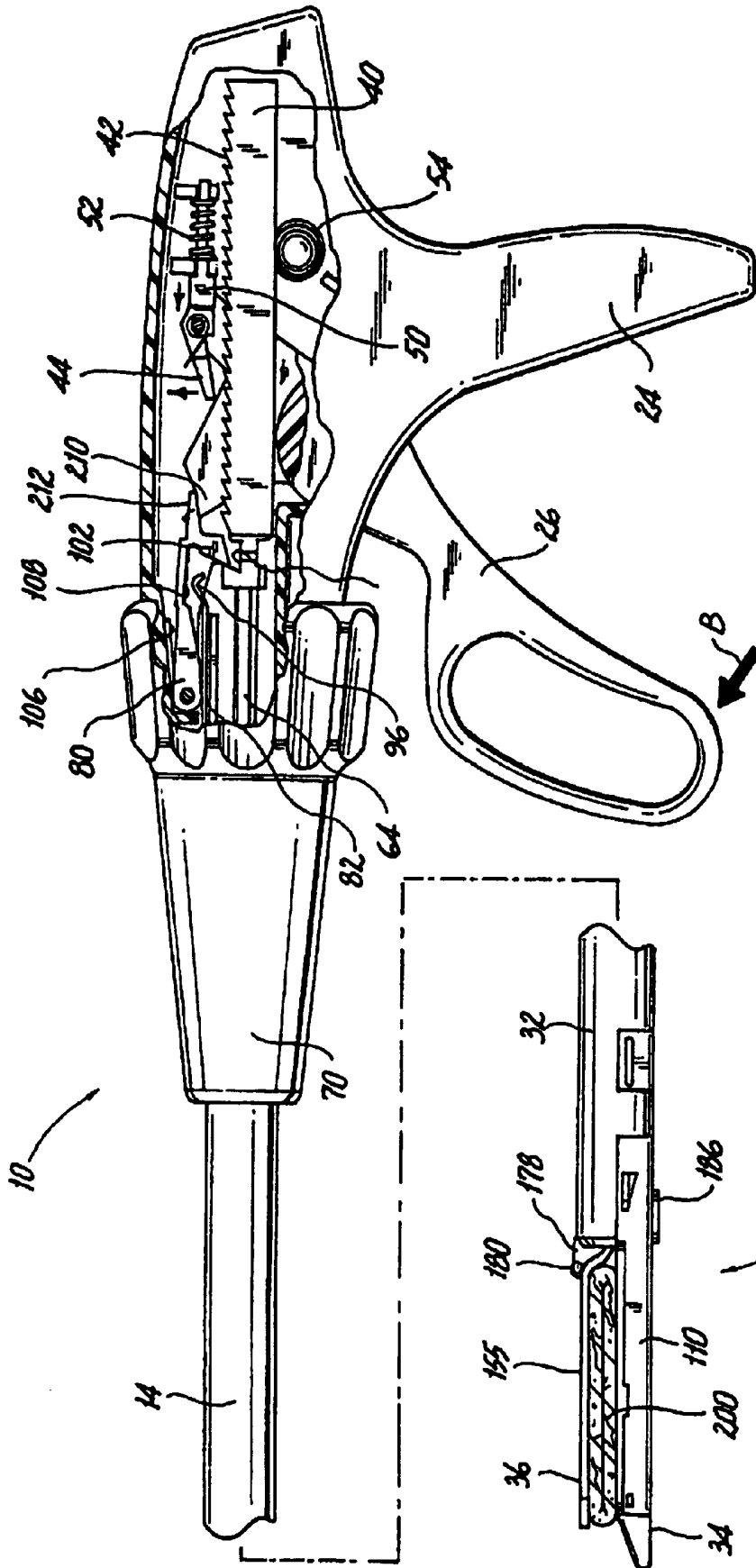

FIG. 8

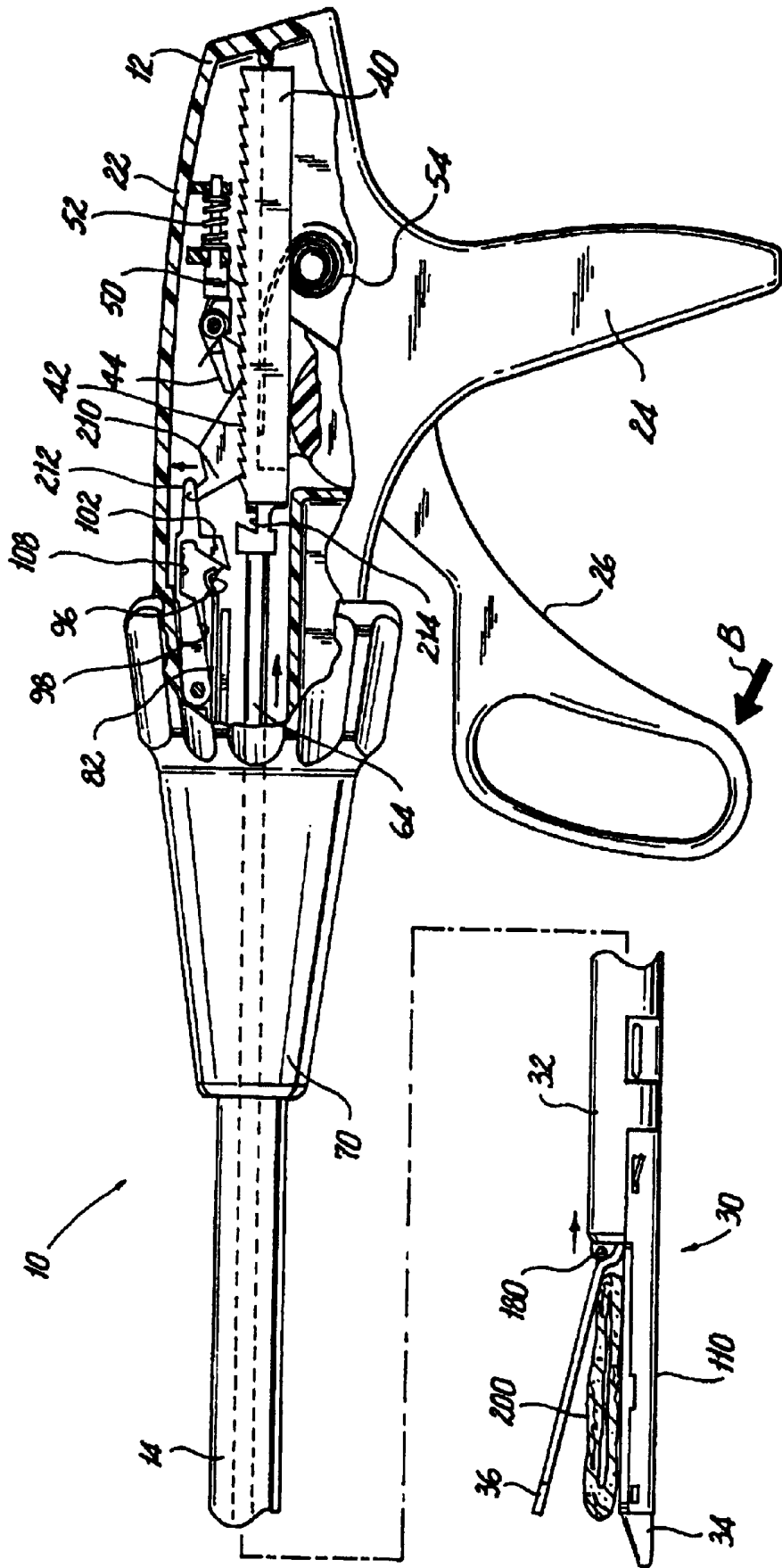

Fig. 9

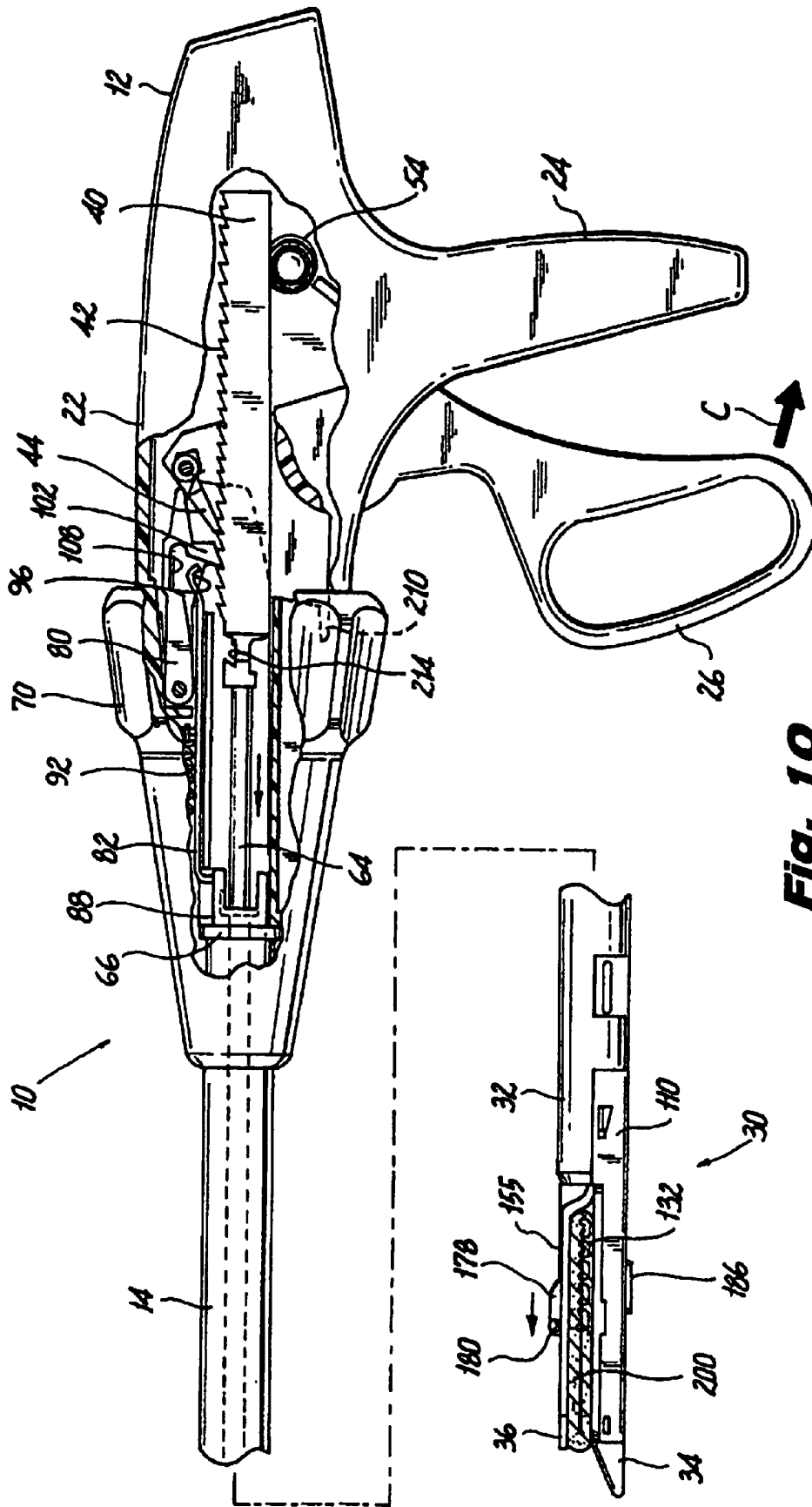

Fig. 10

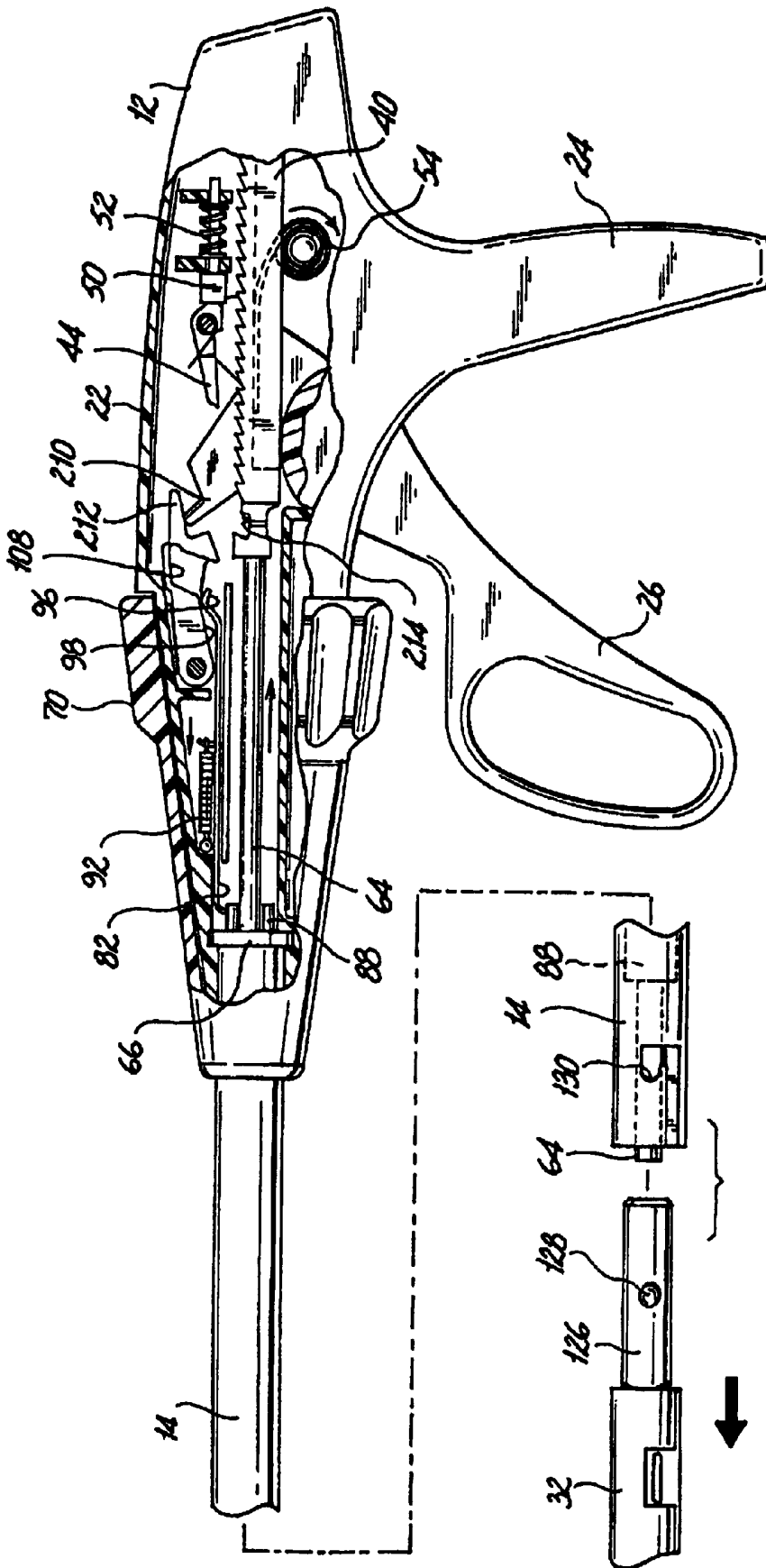

Fig. 11

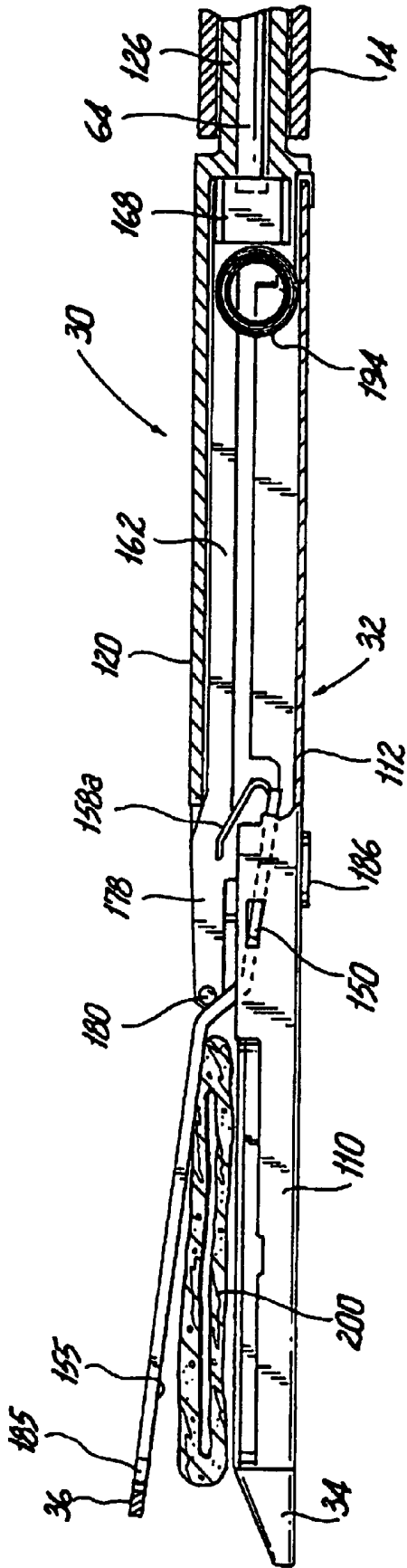

Fig. 12

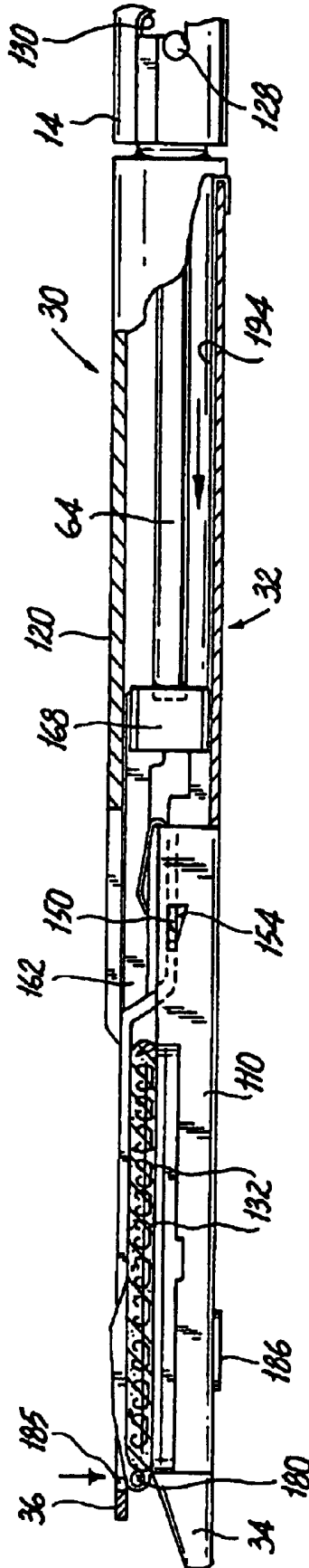

Fig. 13

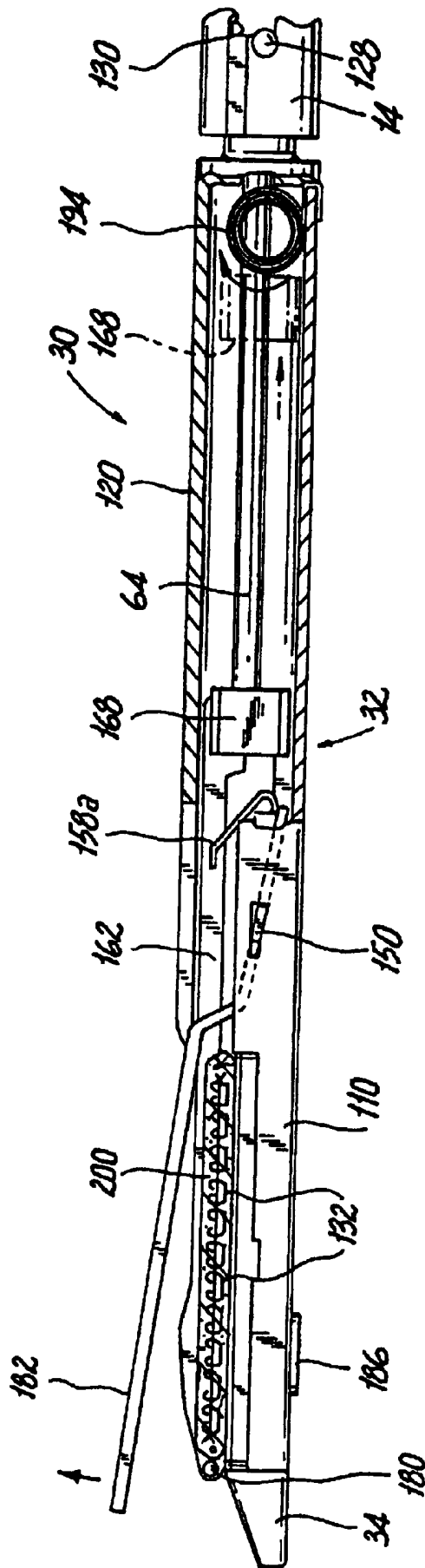

Fig. 14

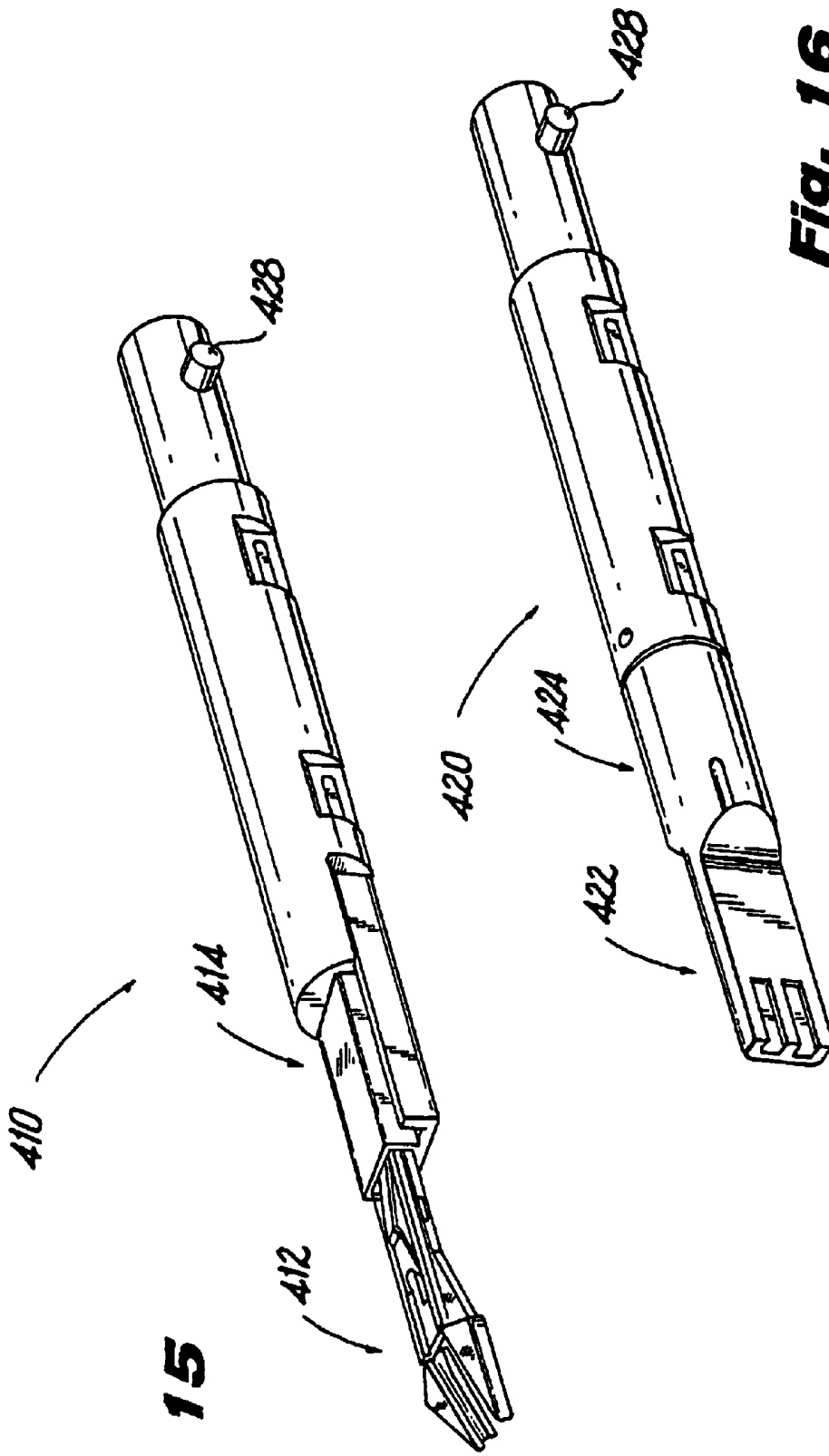

Fig. 15

Fig. 16

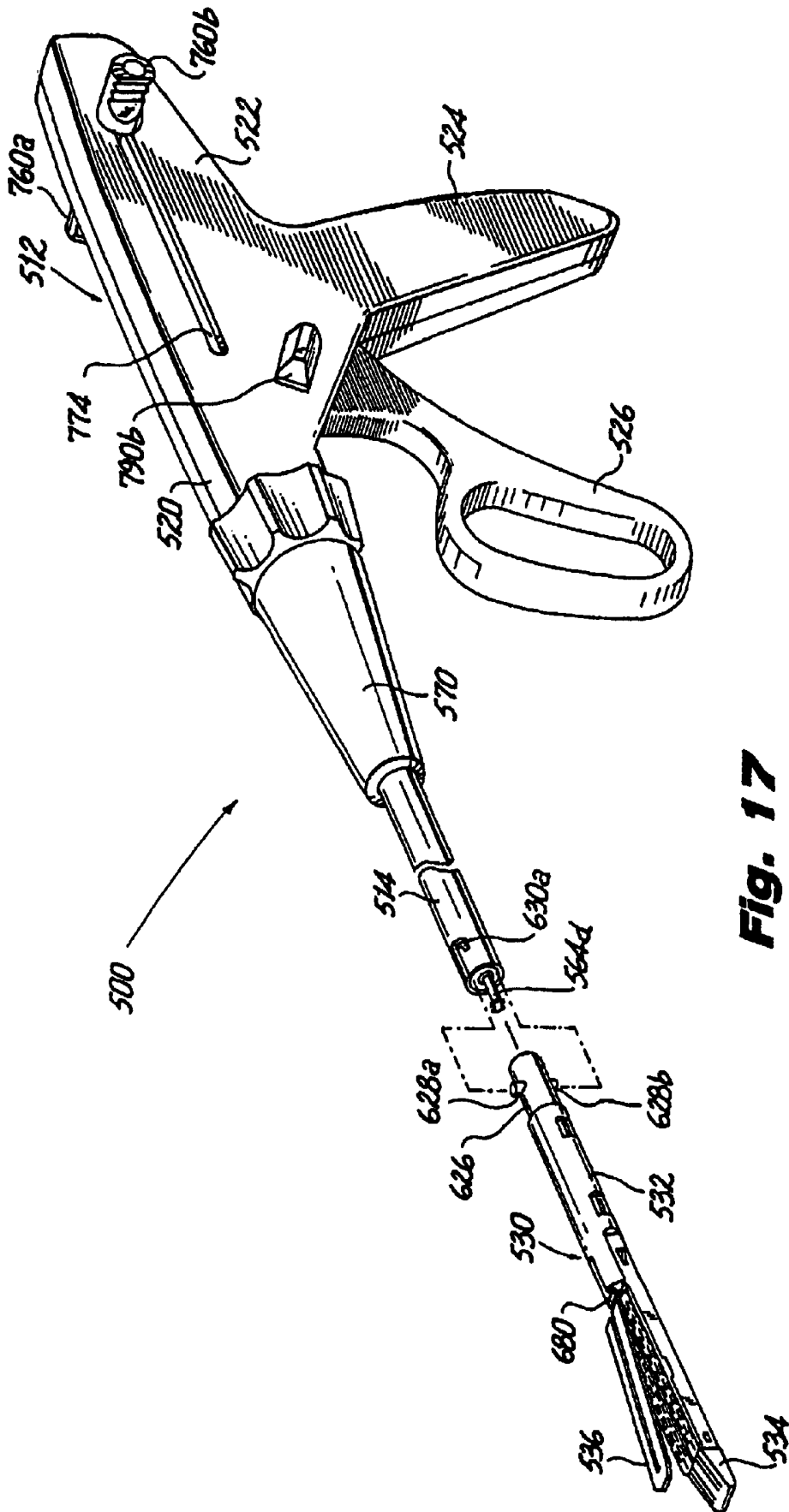

Fig. 17

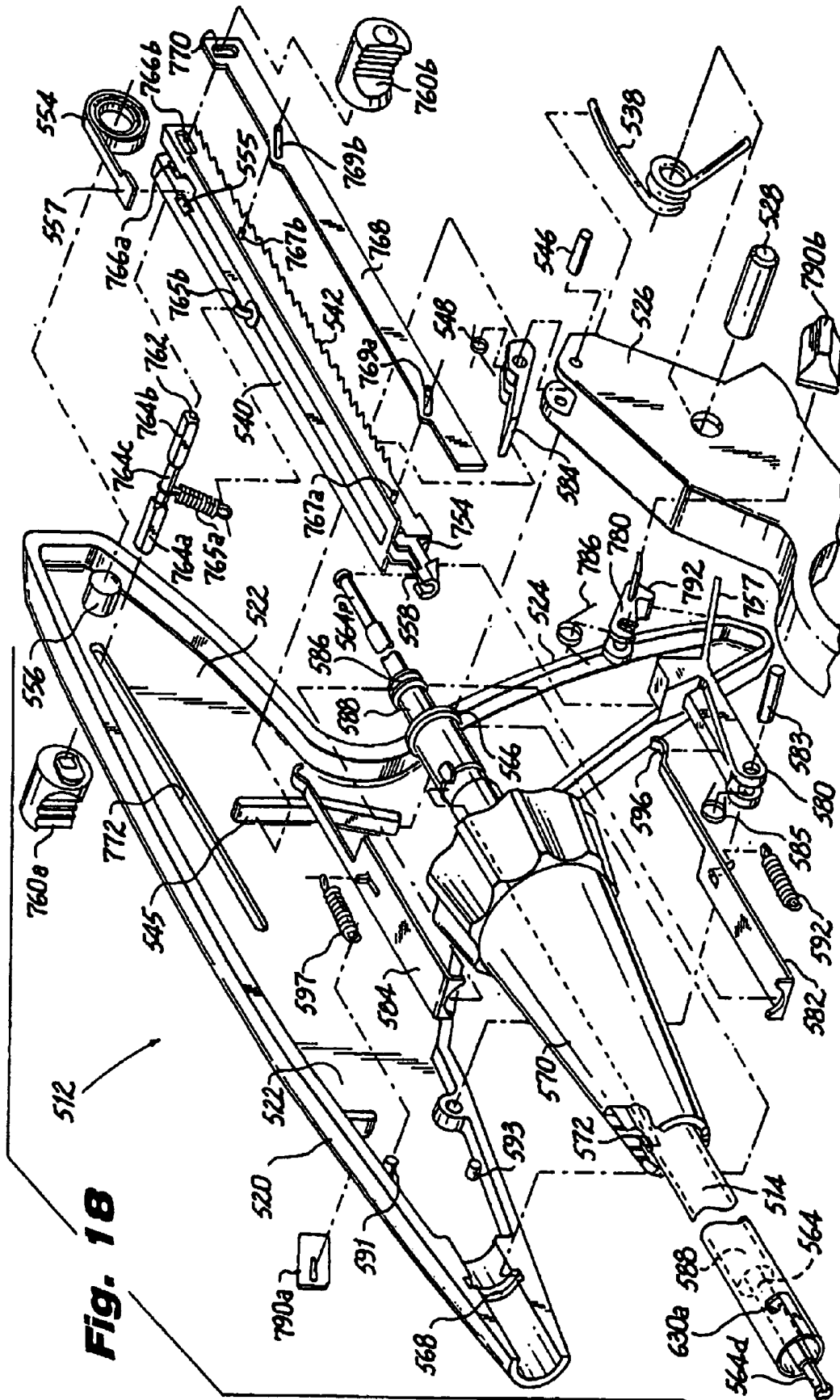
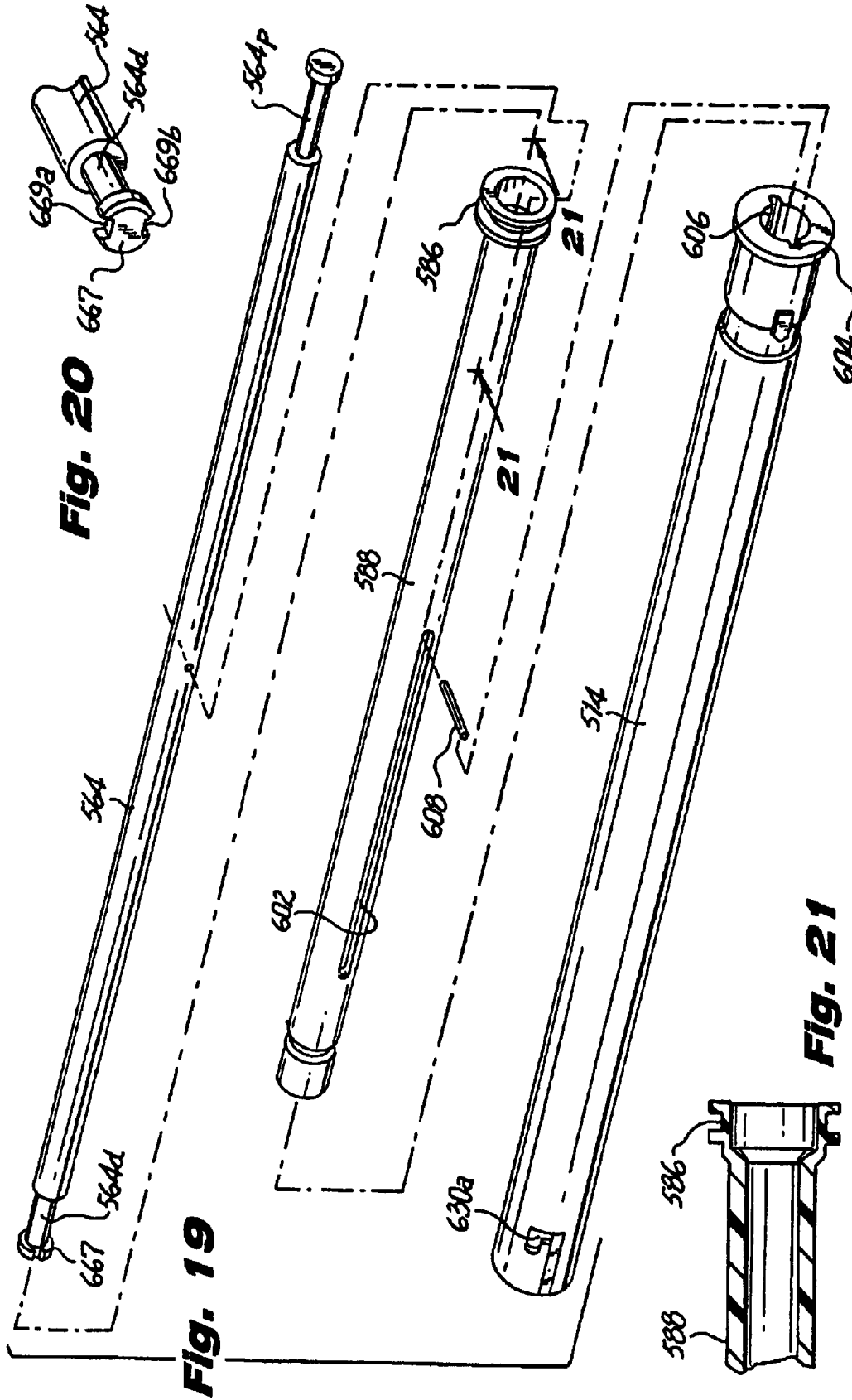

Fig. 18



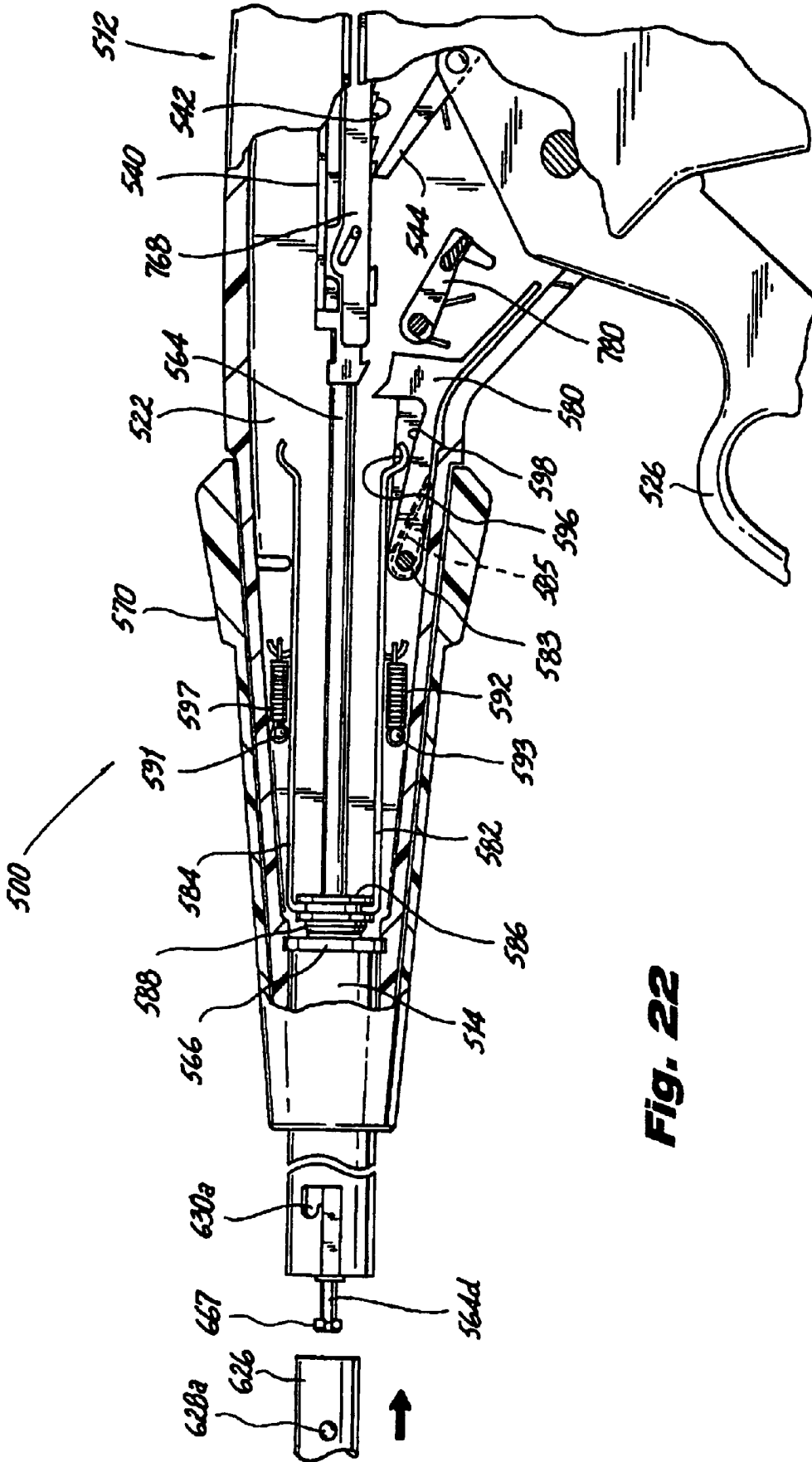

Fig. 22

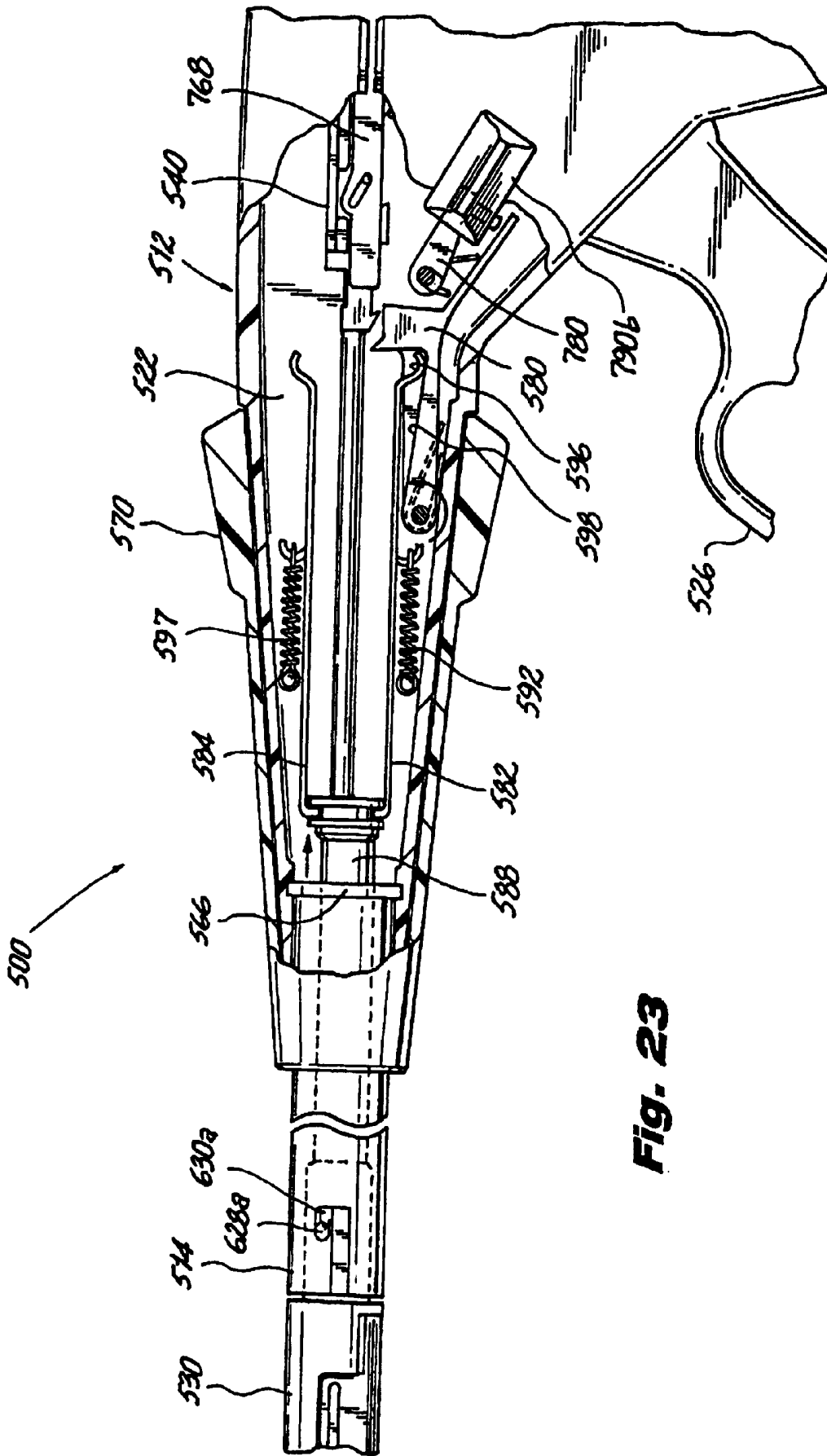

Fig. 23

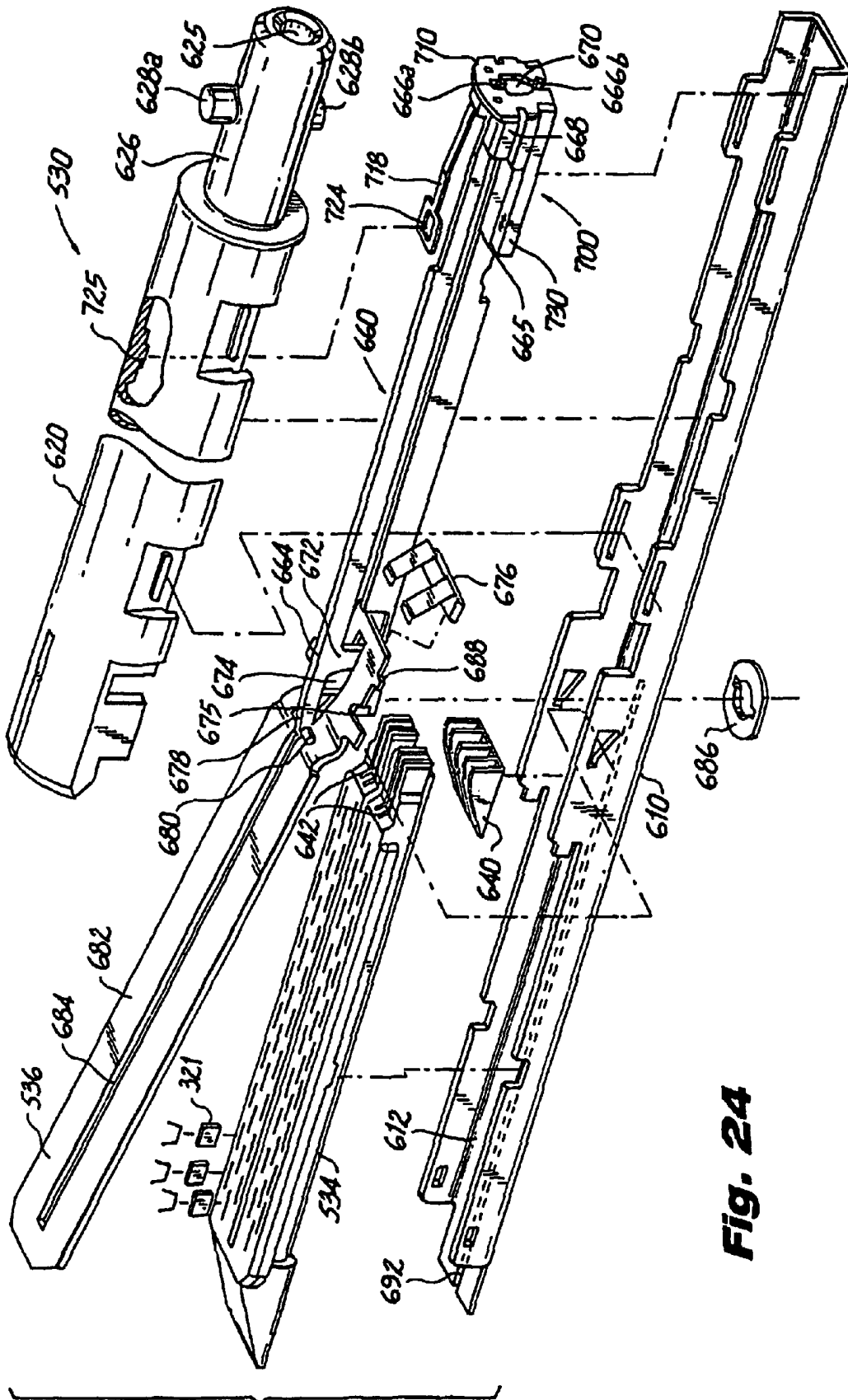

Fig. 24

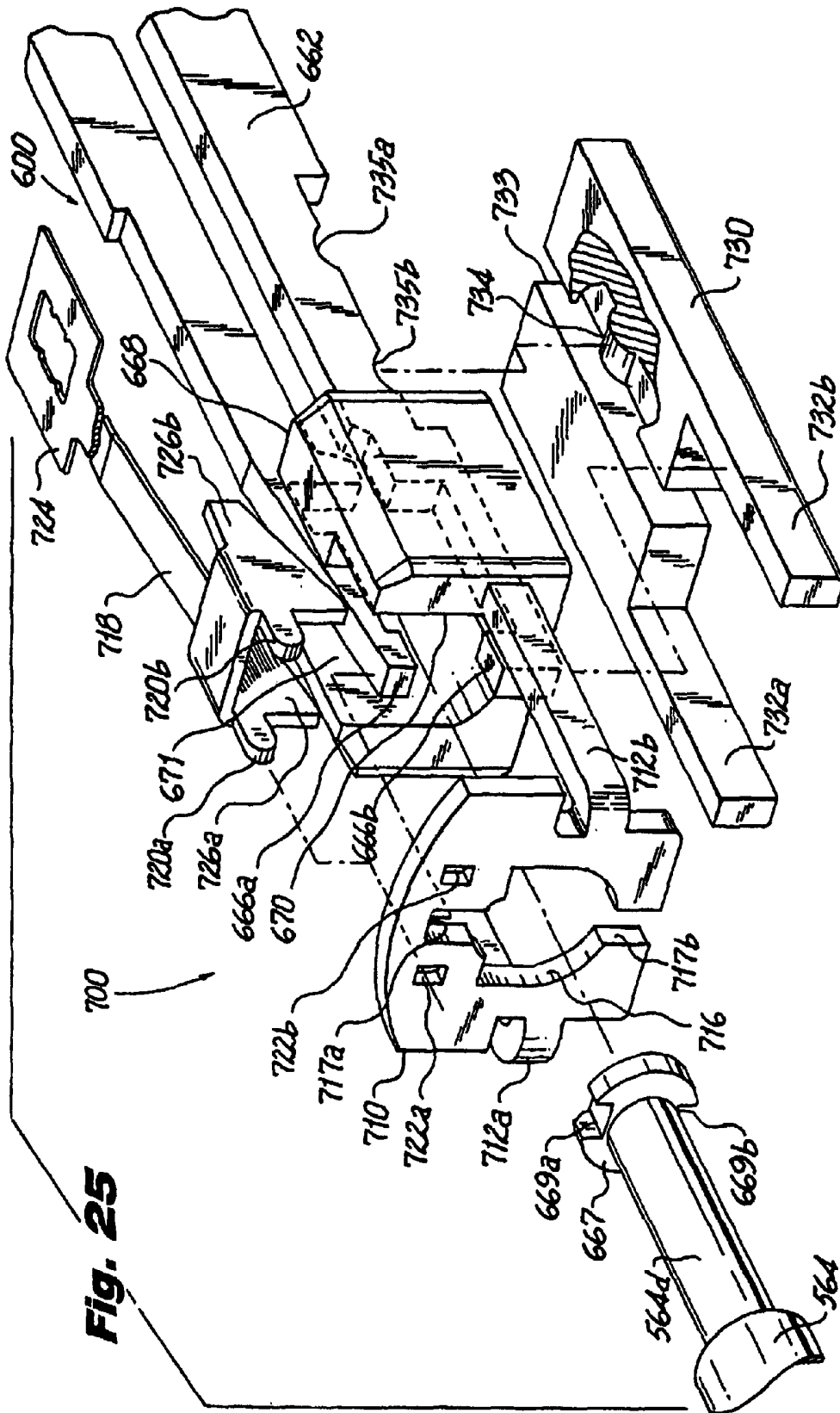

Fig. 25

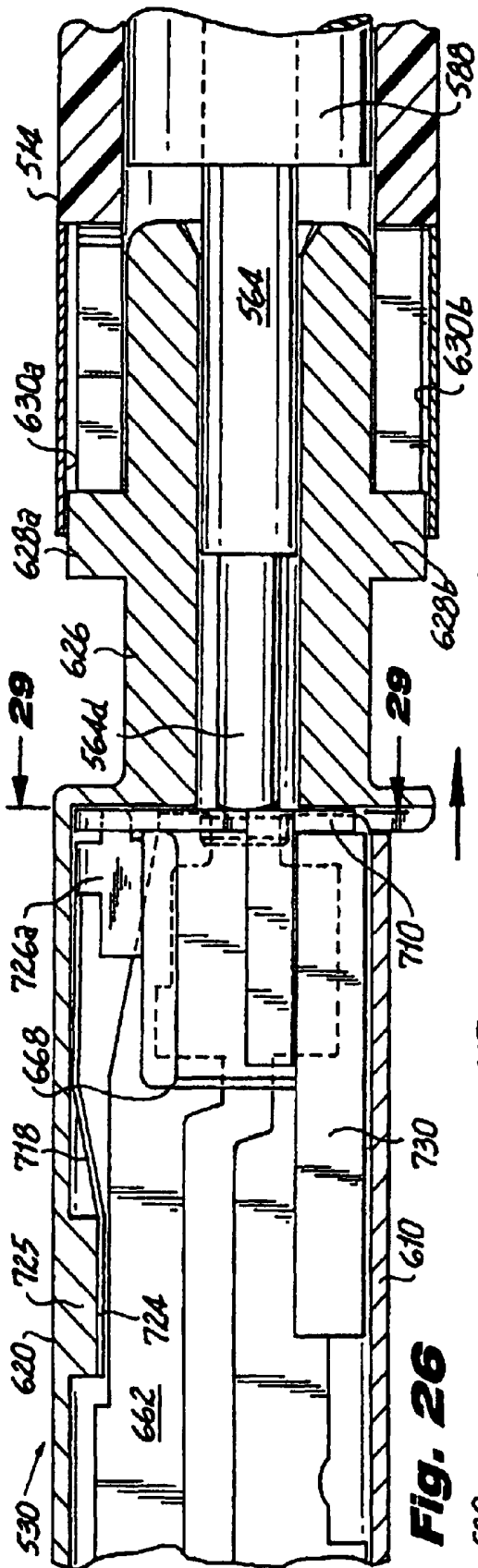

Fig. 26

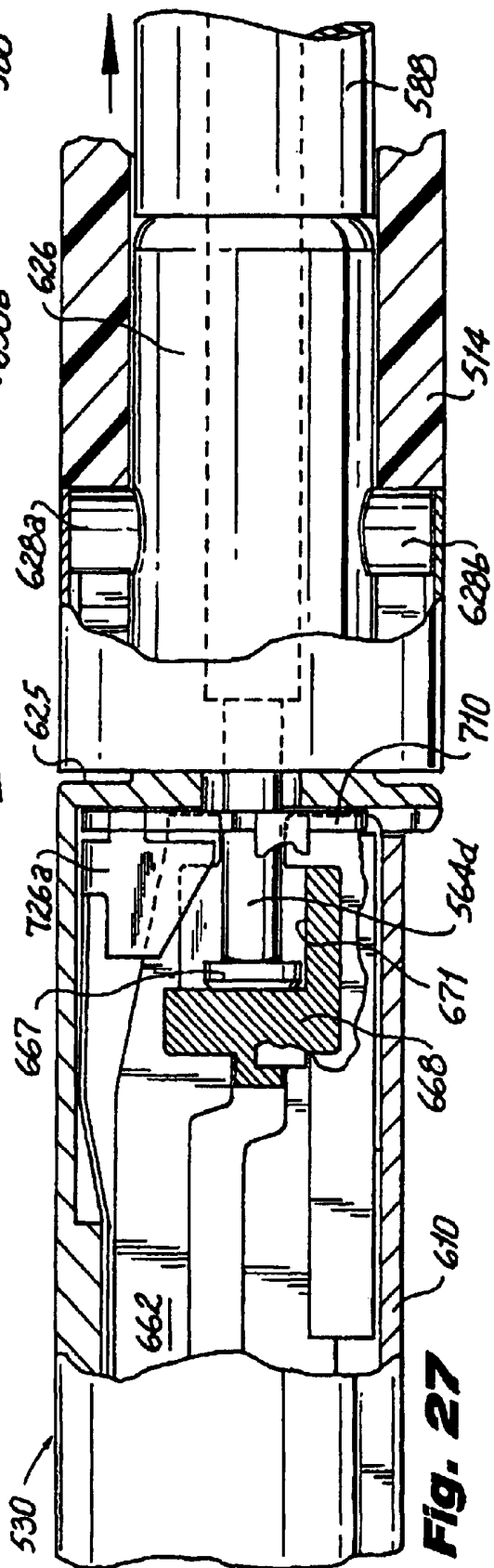

Fig. 27

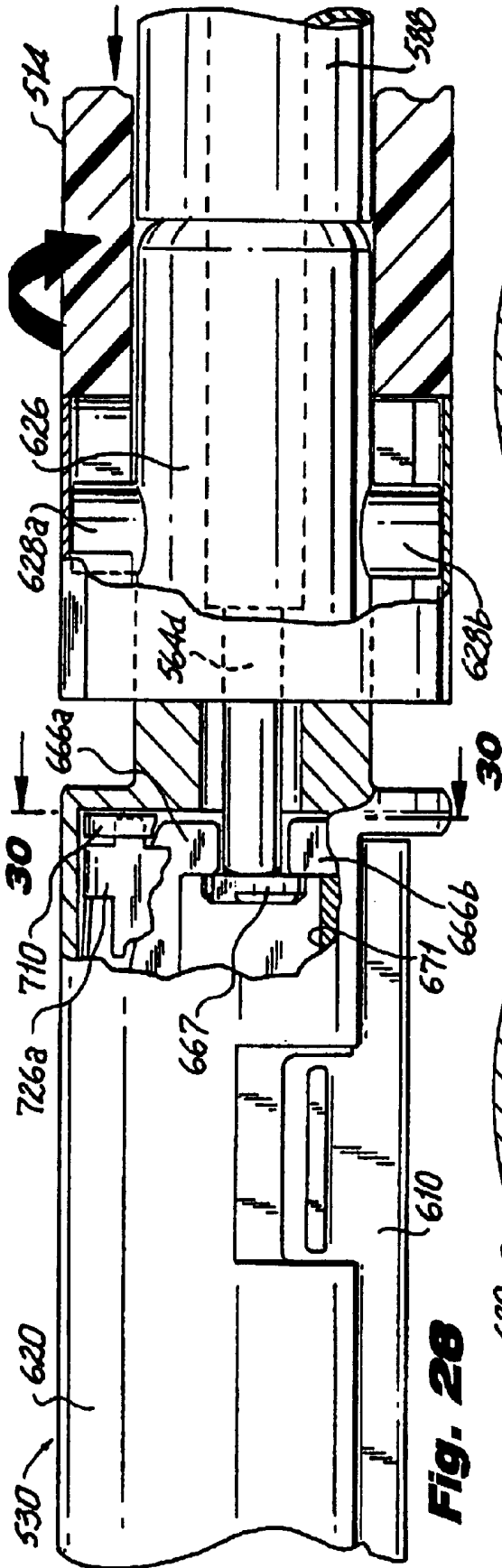

Fig. 28

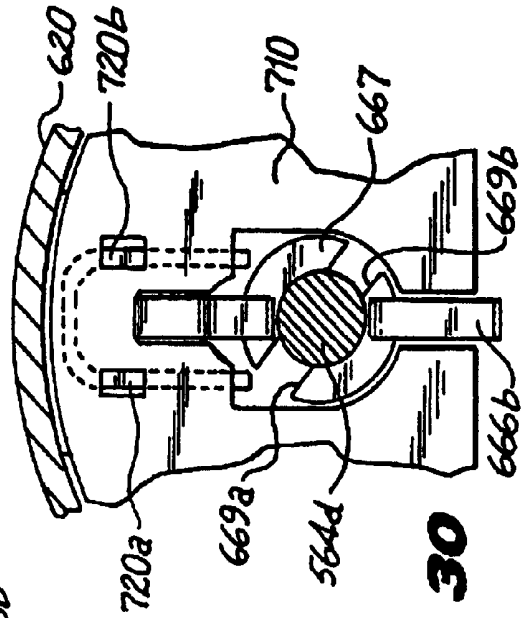

Fig. 30

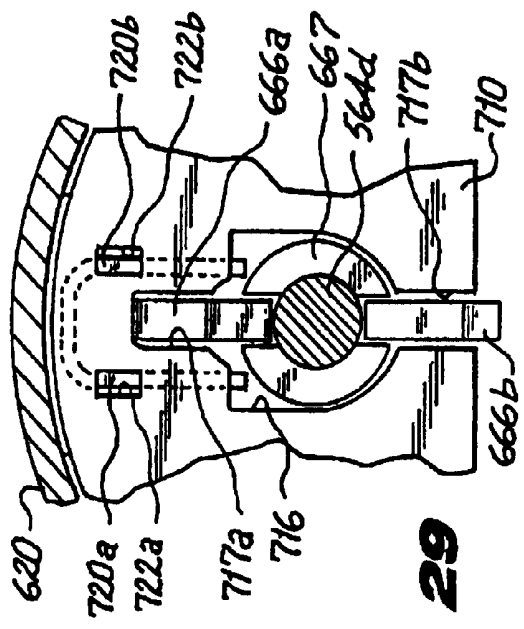

Fig. 29

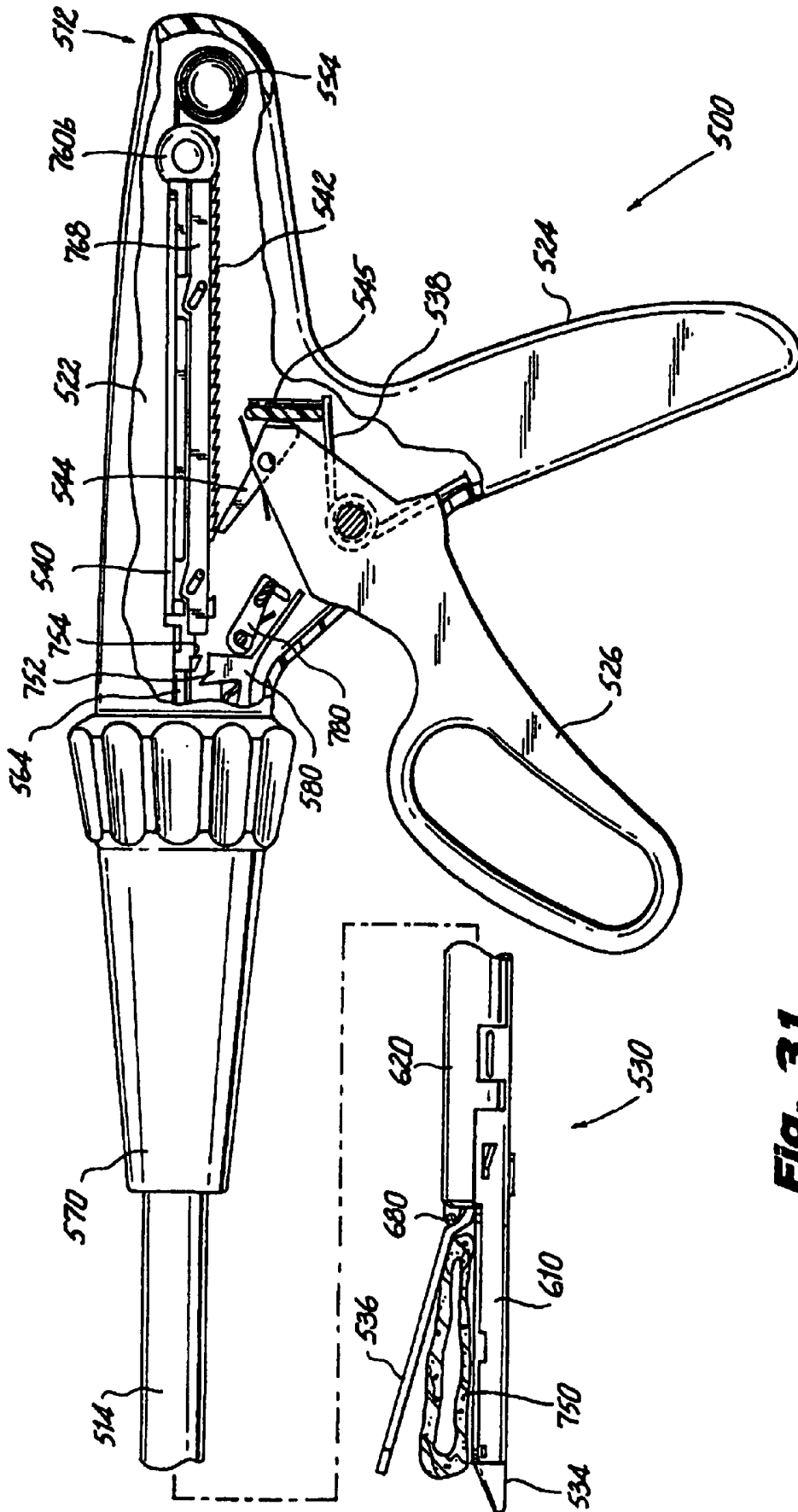

Fig. 31

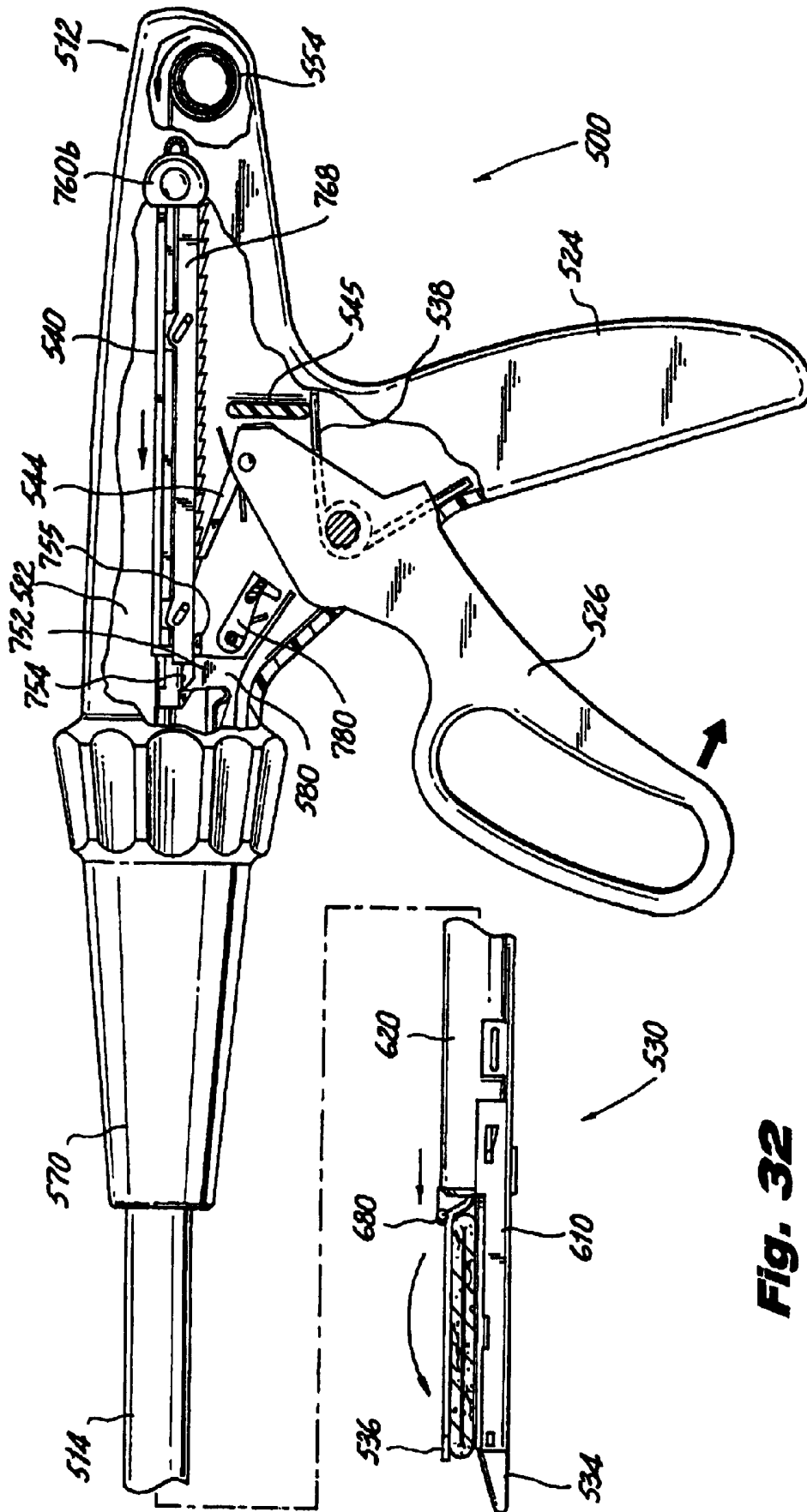

Fig. 32

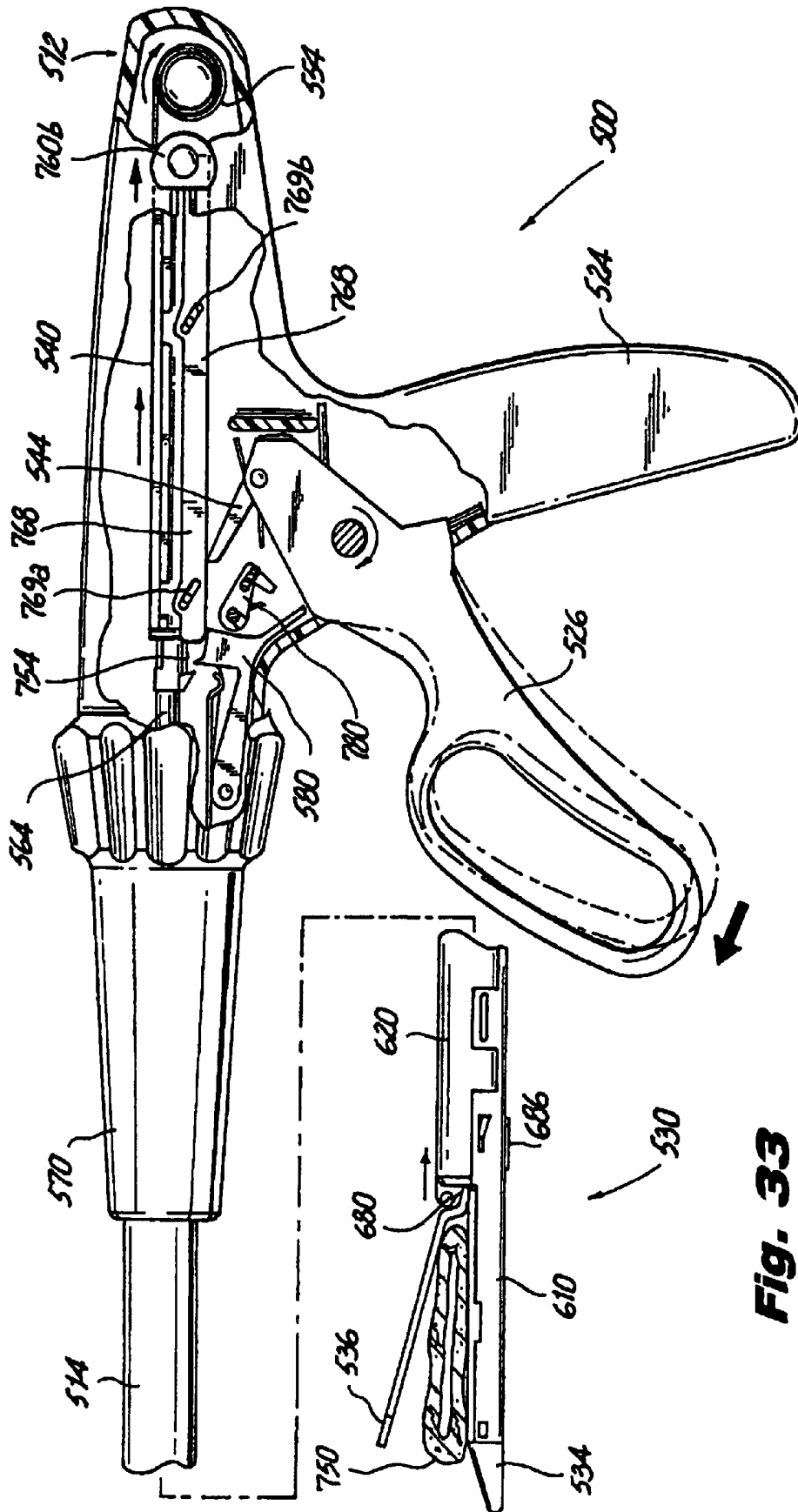

Fig. 33

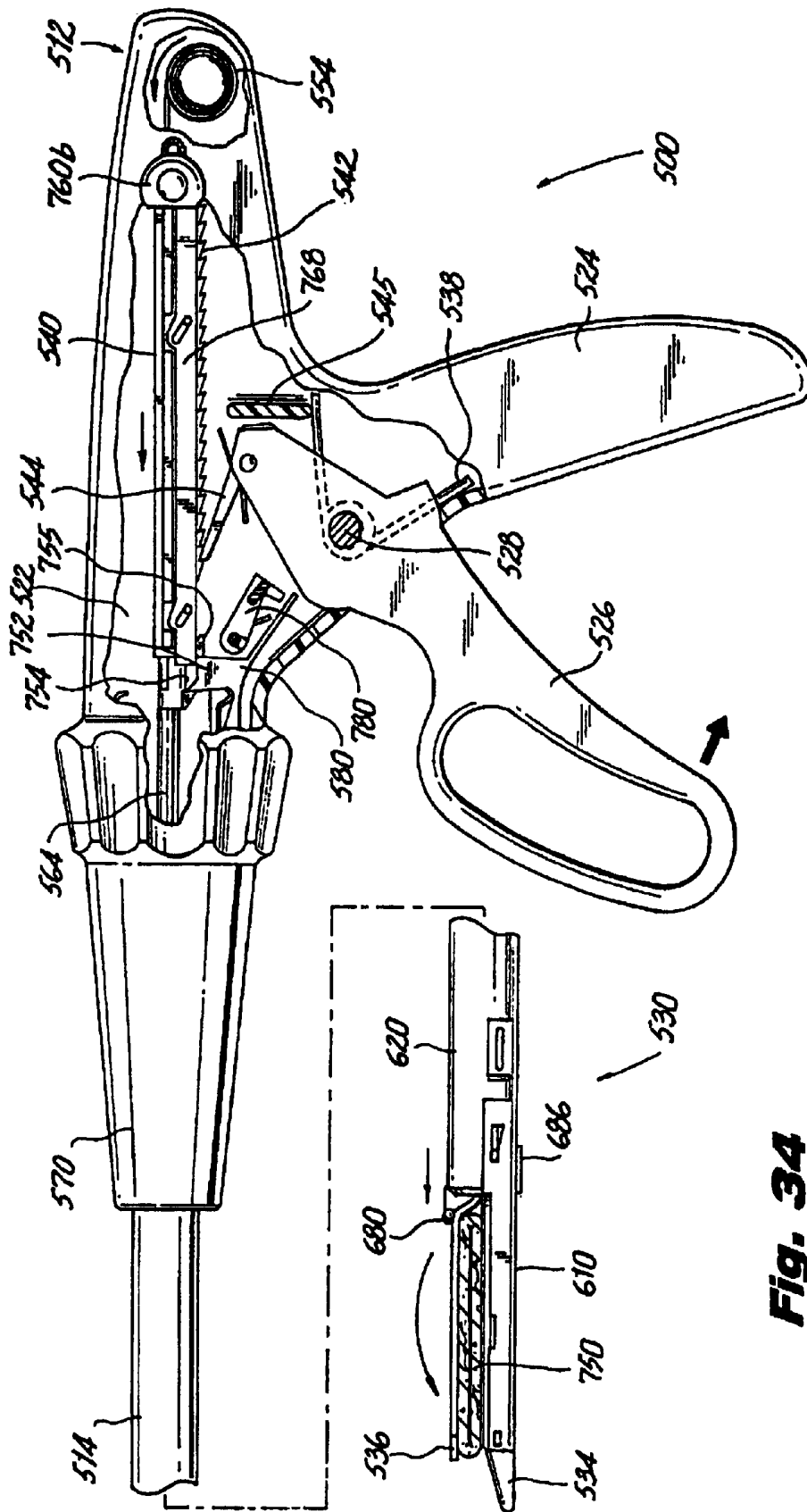

Fig. 34

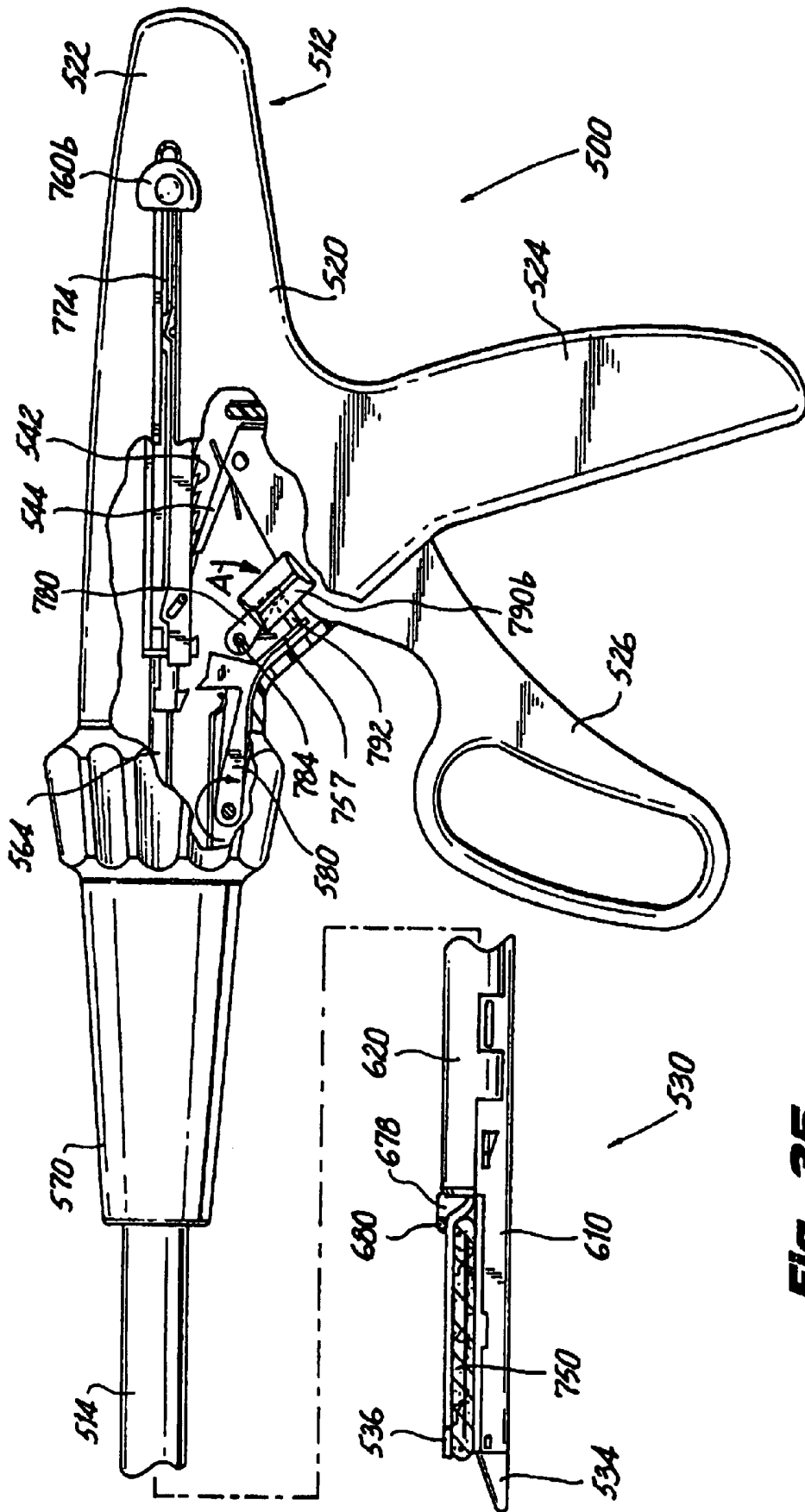

Fig. 35

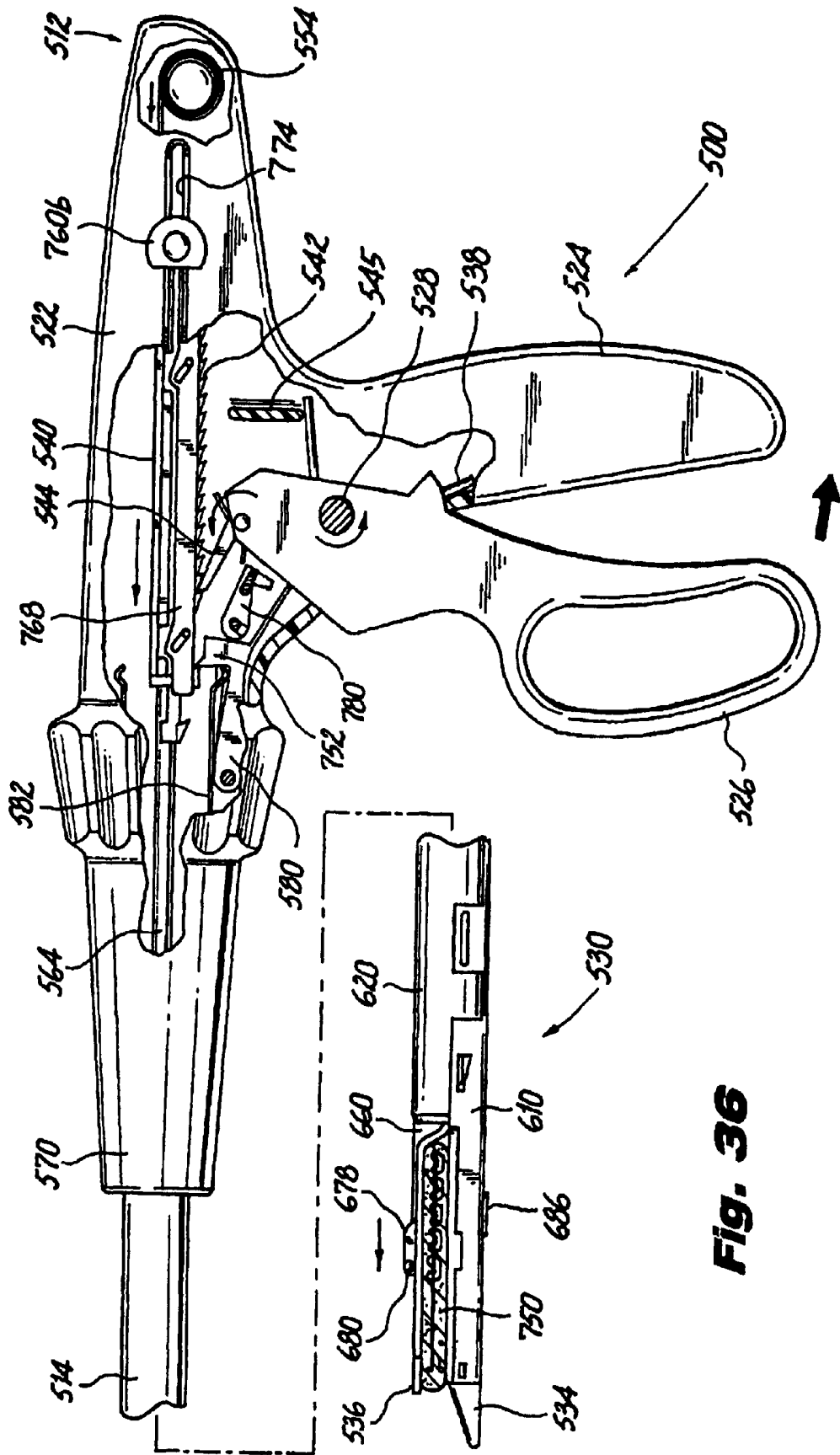

Fig. 36

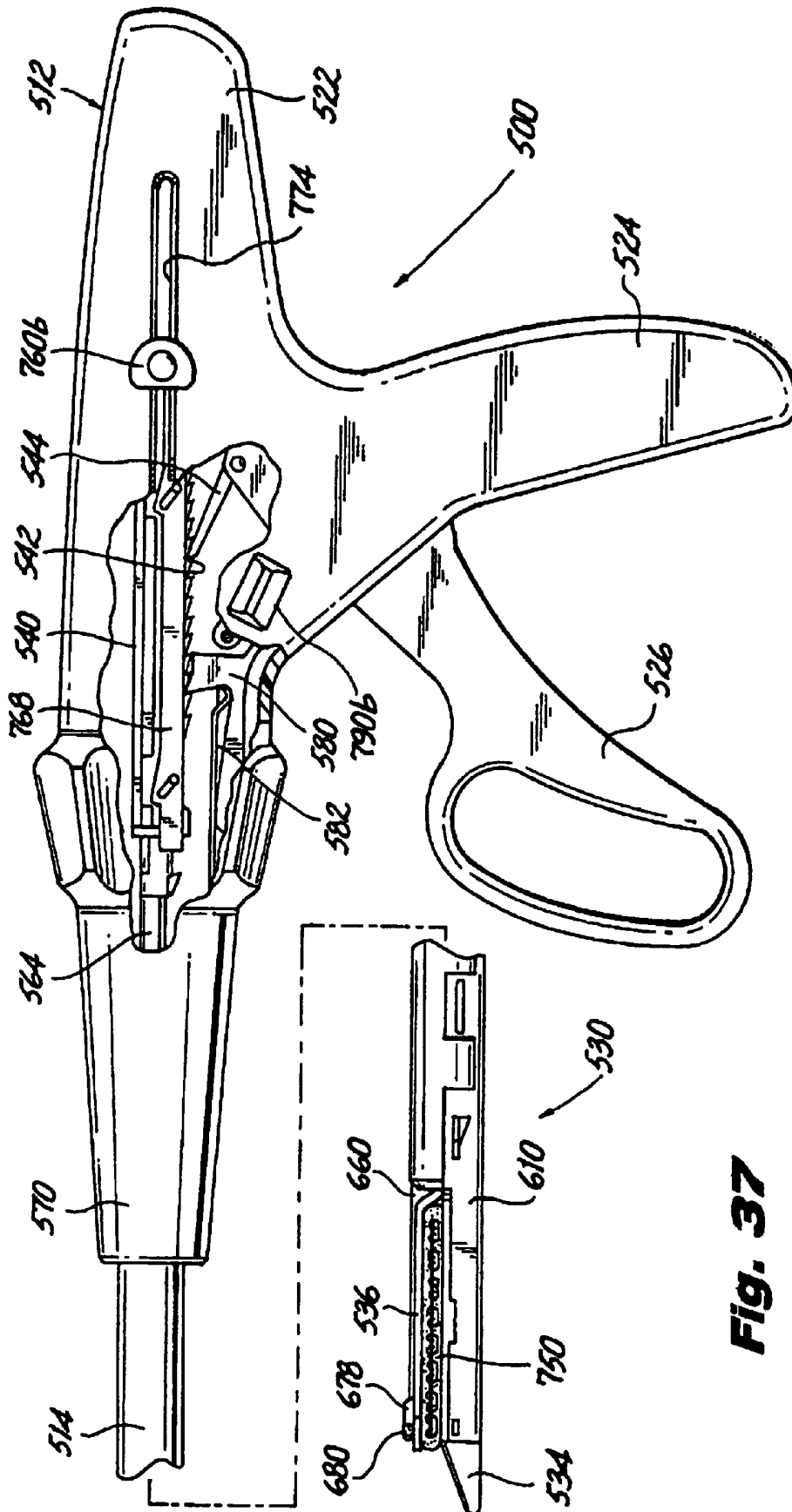

Fig. 37

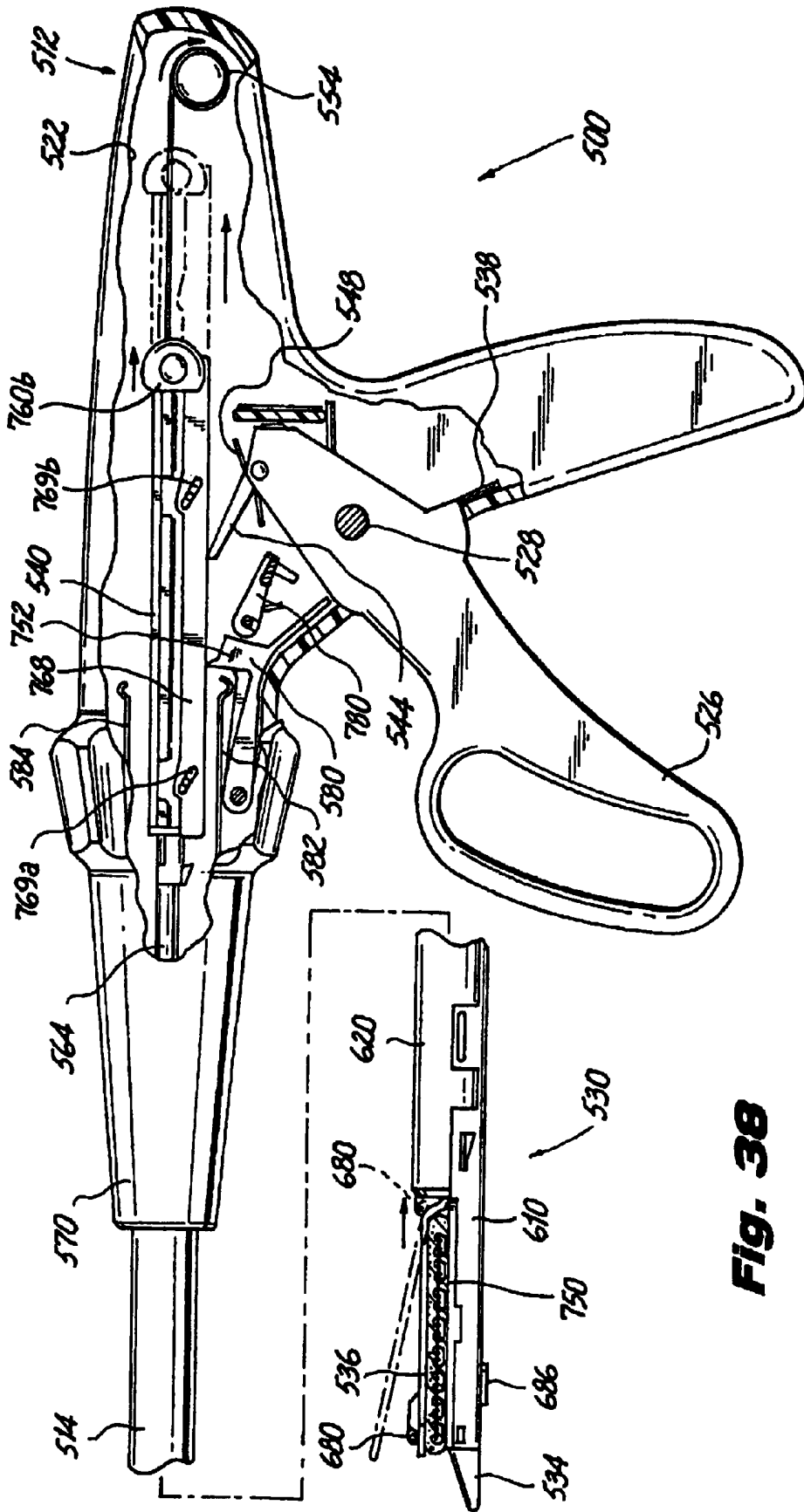
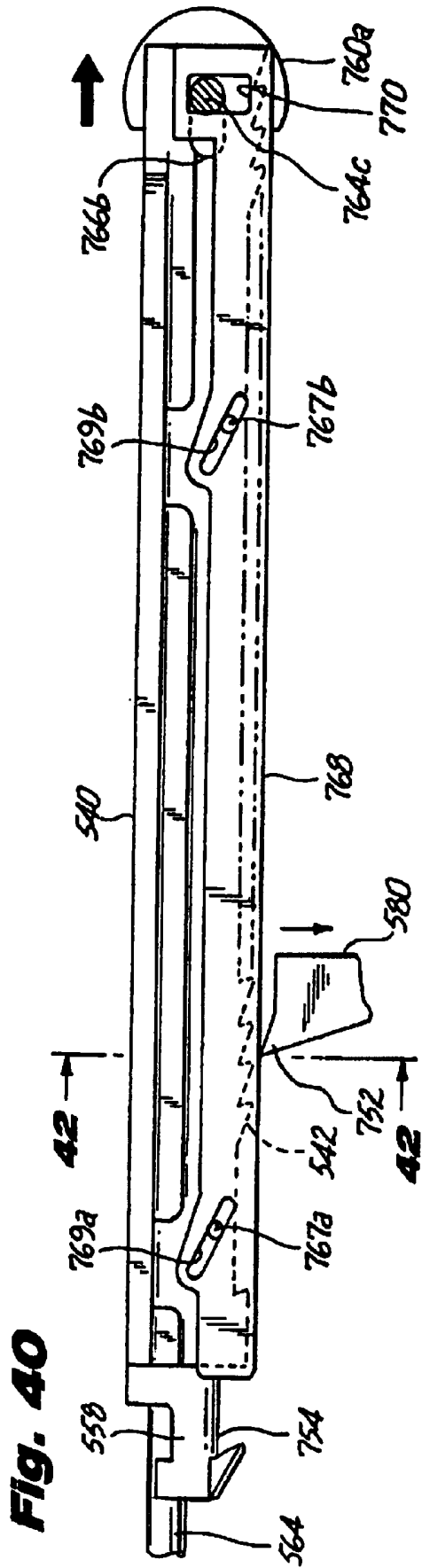
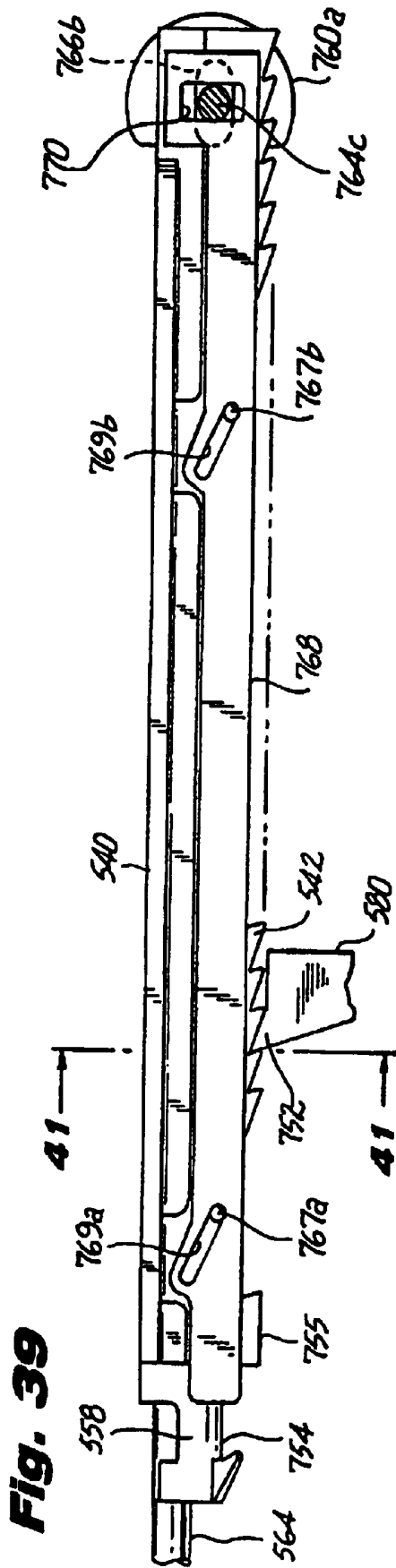

Fig. 38



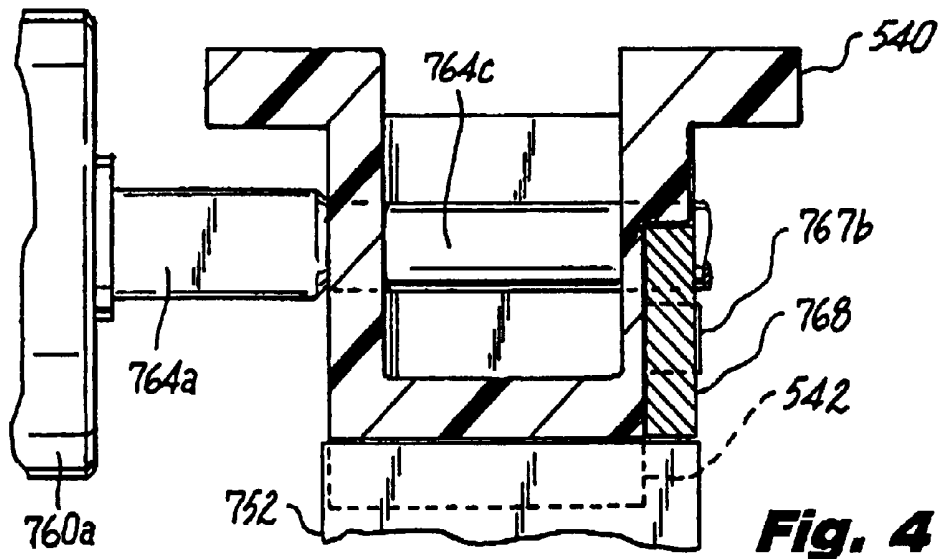

Fig. 41

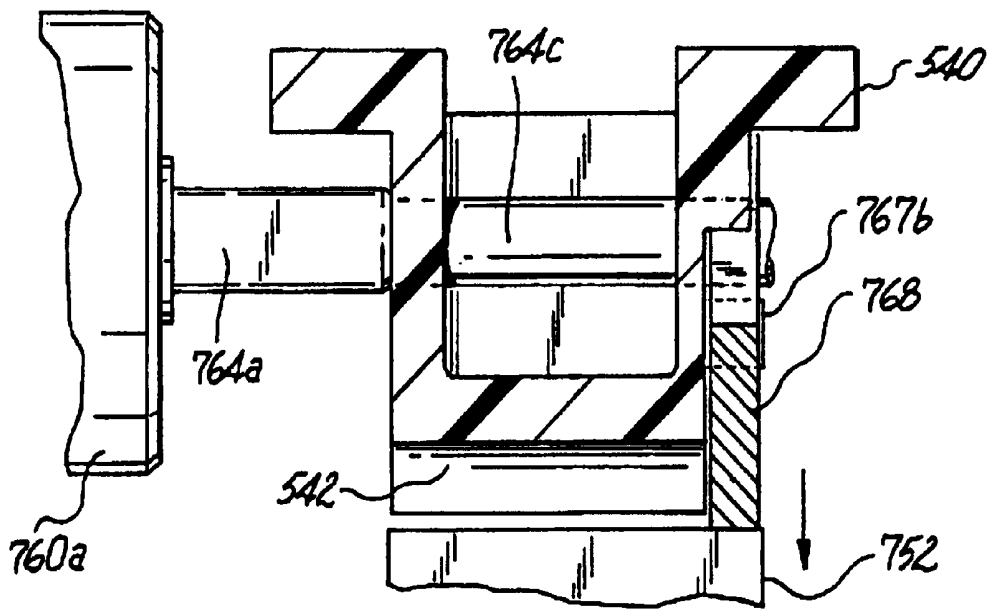

Fig. 42

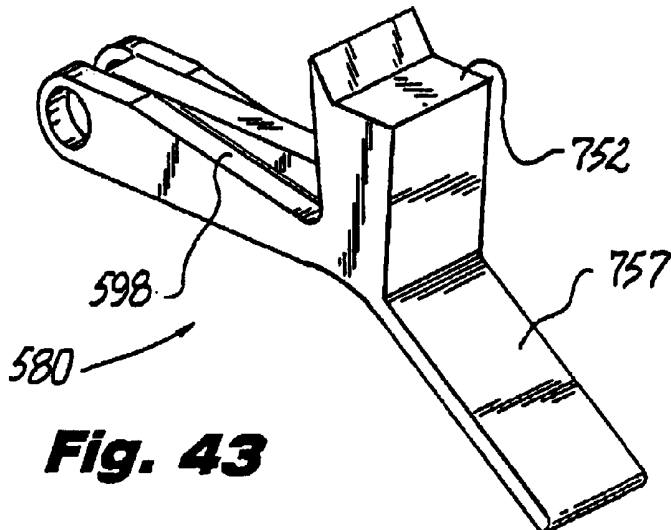

Fig. 43

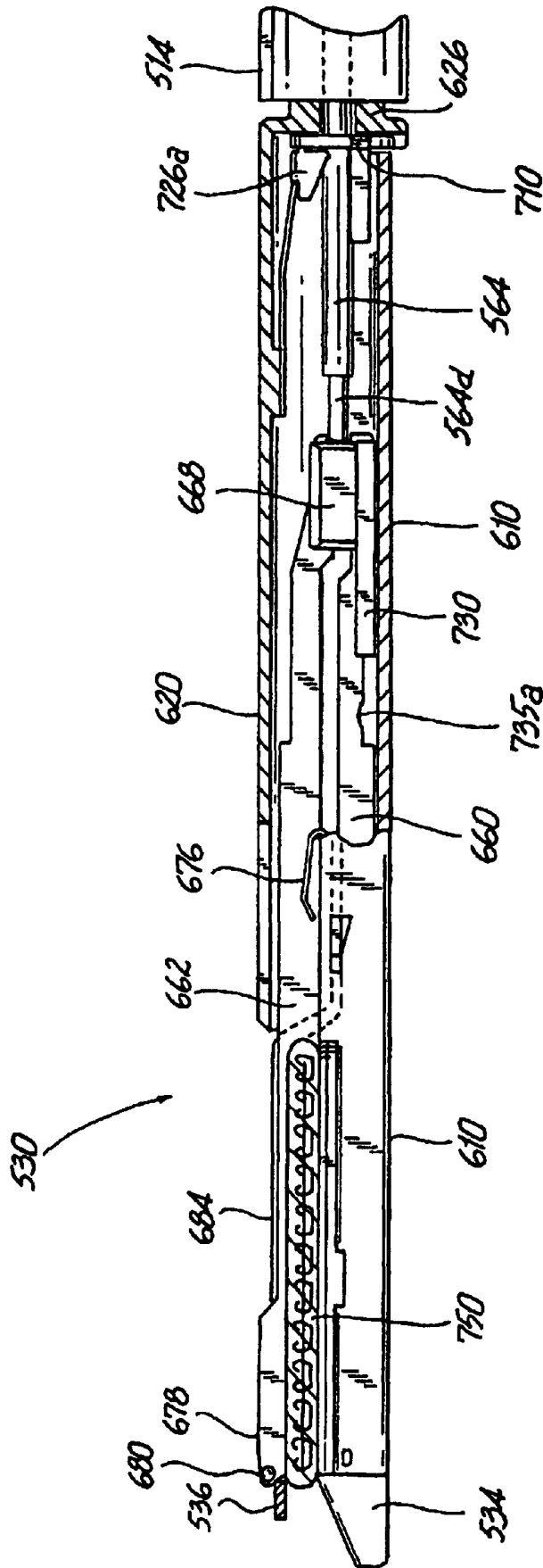
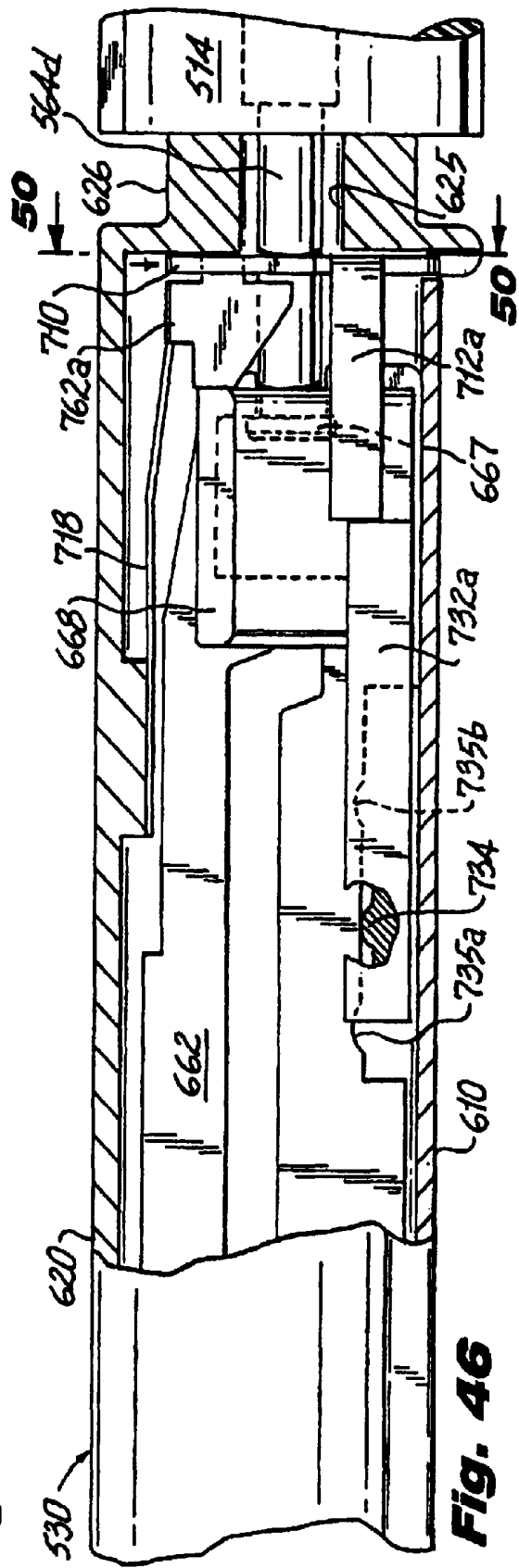
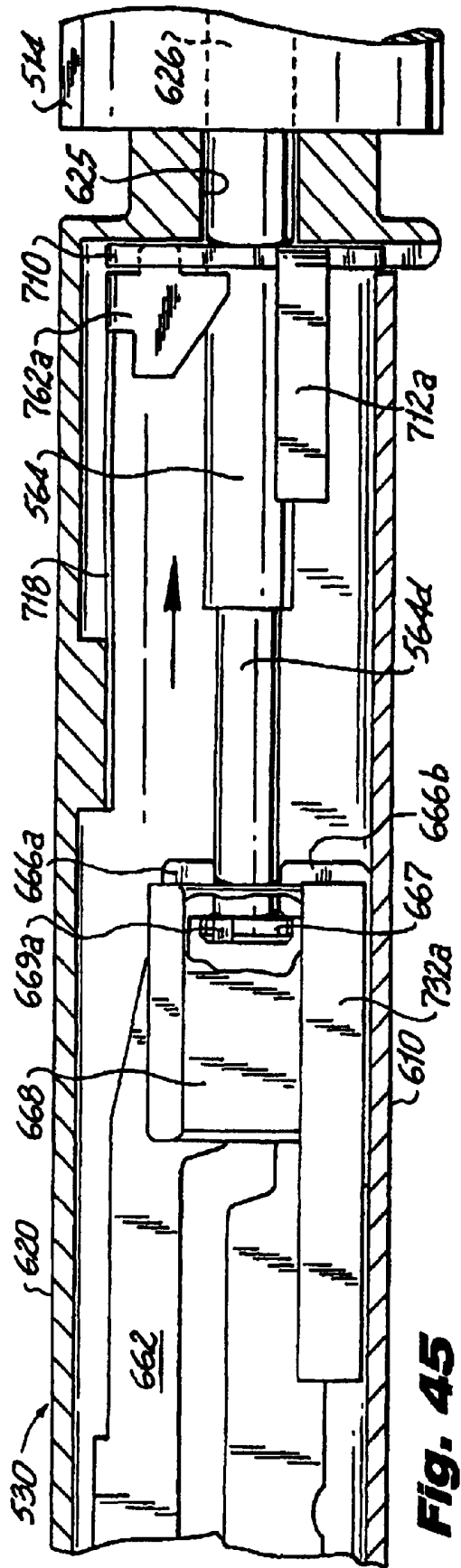

Fig. 44



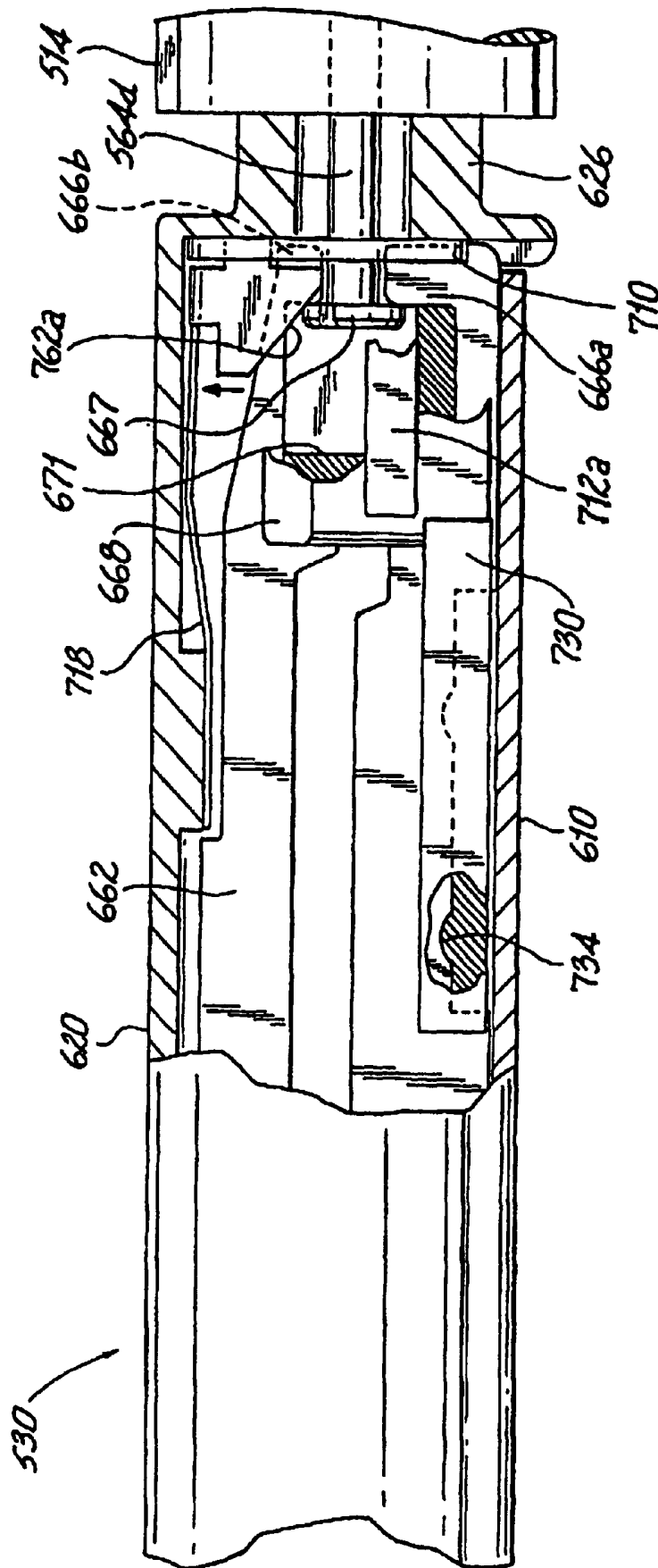

Fig. 47

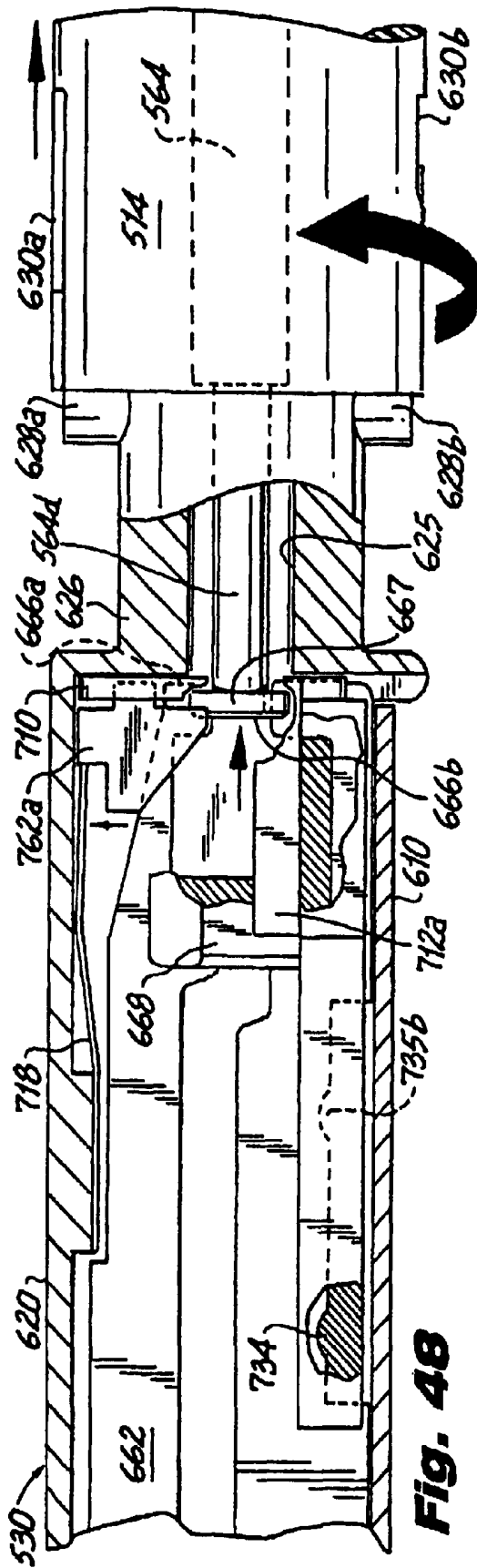

Fig. 48

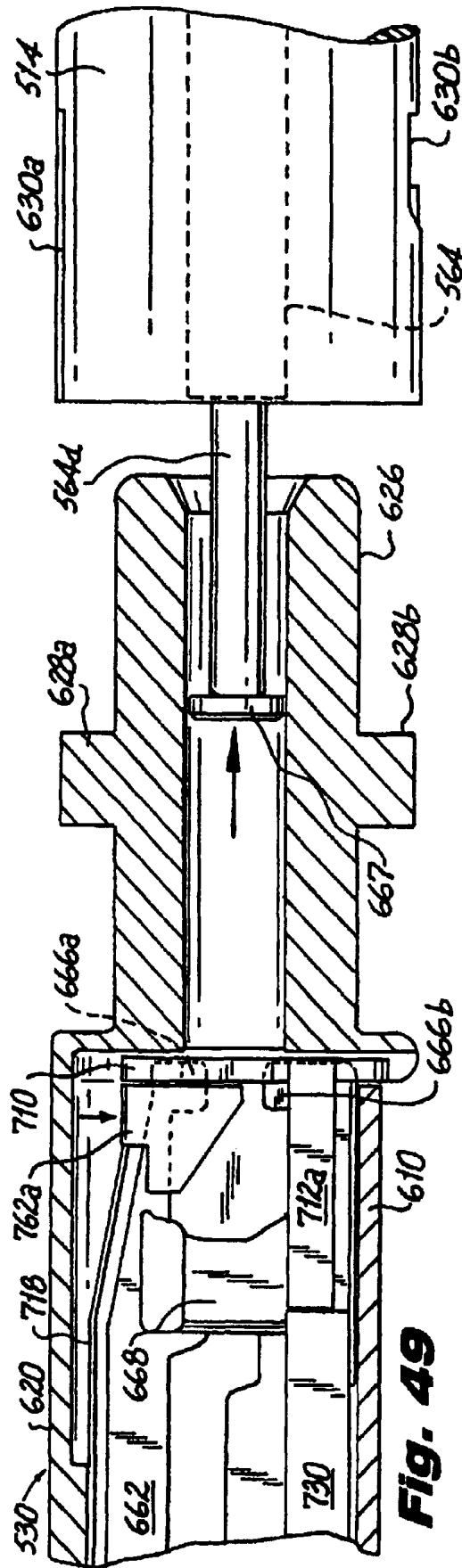

Fig. 49

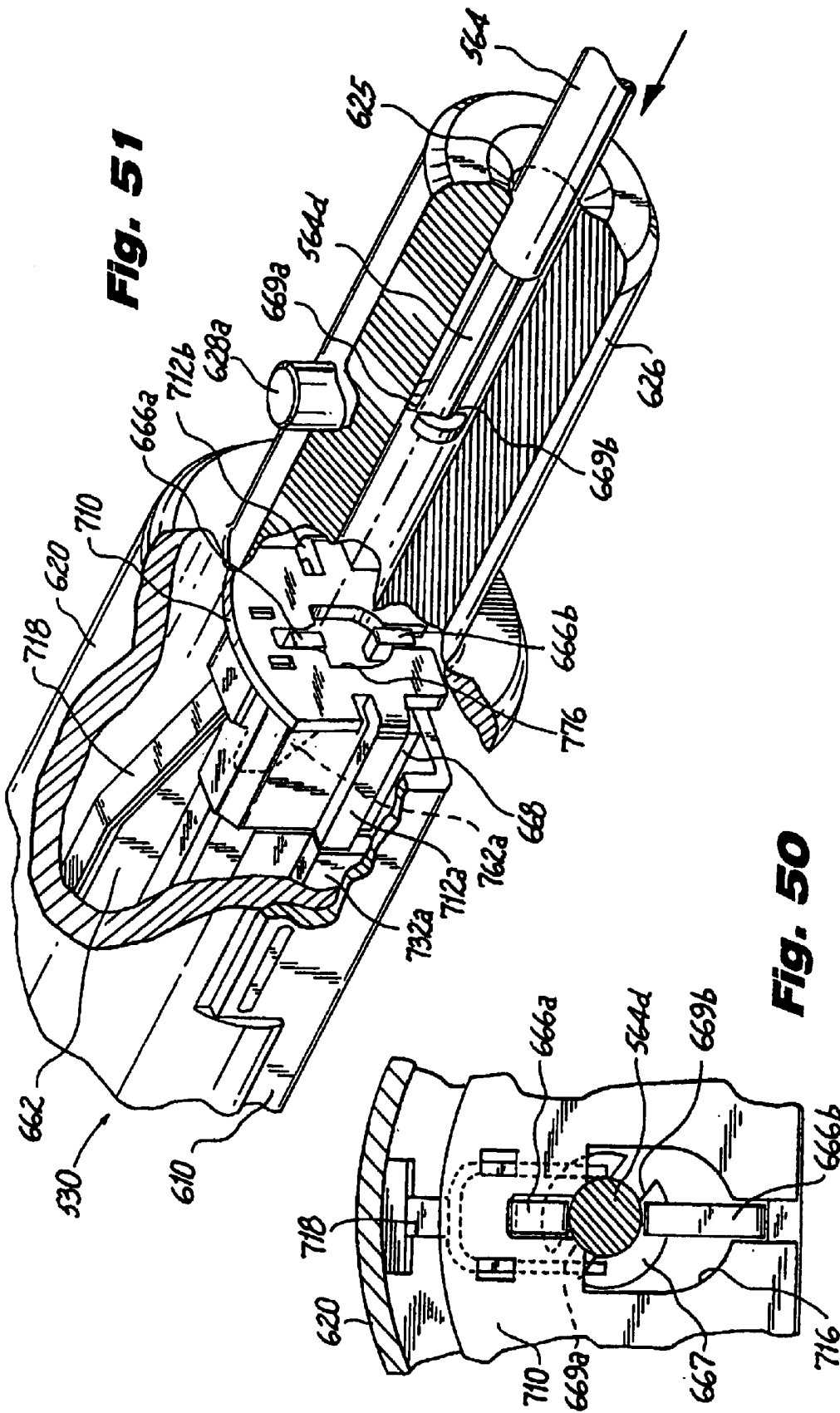

Fig. 51

Fig. 50

SURGICAL STAPLER

Matter enclosed in heavy brackets [] appears in the original patent but forms no part of this reissue specification; matter printed in italics indicates the additions made by reissue.

CROSS-REFERENCE TO RELATED APPLICATION

[This application is a continuation-in-part of application Ser. No. 08/520,202 filed Aug. 28, 1995, now U.S. Pat. No. 5,762,256.] *This application is a continuation of application Ser. No. 08/546,253, filed Oct. 20, 1995, now U.S. Pat. No. 5,782,396, which is a continuation-in-part of application Ser. No. 08/520,202, filed Aug. 28, 1995, now U.S. Pat. No. 5,762,256.*

BACKGROUND

1. Technical Field

This application relates to a surgical stapling apparatus, and more particularly, to an apparatus for sequentially applying a plurality of surgical-fasteners to body tissue and optionally incising the fastened tissue.

2. Background of Related Art

Surgical devices wherein tissue is first grasped or clamped between opposing jaw structure and then joined by surgical fasteners are well known in the art. In some instruments a knife is provided to cut the tissue which has been joined by the fasteners. The fasteners are typically in the form of surgical staples but two part polymeric fasteners can also be utilized.

Instruments for this purpose can include two elongated members which are respectively used to capture or clamp tissue. Typically, one of the members carries a staple cartridge which houses a plurality of staples arranged in at least two lateral rows while the other member has an anvil that defines a surface for forming the staple legs as the staples are driven from the staple cartridge. Generally, the stapling operation is effected by cam bars that travel longitudinally through the staple cartridge, with the cam bars acting upon staple pushers to sequentially eject the staples from the staple cartridge. A knife can travel between the staple rows to longitudinally cut and/or open the stapled tissue between the rows of staples. Such instruments are disclosed, for example, in U.S. Pat. Nos. 3,079,606 and 3,490,675.

A later stapler disclosed in U.S. Pat. No. 3,499,591 applies a double row of staples on each side of the incision. This is accomplished by providing a disposable loading unit in which a cam member moves through an elongate guide path between two sets of staggered staple carrying grooves. Staple drive members are located within the grooves that are positioned in such a manner so as to be contacted by the longitudinally moving cam to effect ejection of the staples from the staple cartridge of the disposable loading unit. Other examples of such staplers are disclosed in U.S. Pat. Nos. 4,429,695 and 5,065,929.

Each of the instruments described above were designed for use in conventional surgical procedures wherein surgeons have direct manual access to the operative site. However, in endoscopic or laparoscopic procedures, surgery is performed through a small incision or through a narrow cannula inserted through small entrance wounds in the skin. In order to address the specific needs of endoscopic and/or laparoscopic surgical procedures, endoscopic surgical stapling devices have been developed and are disclosed in, for

example, U.S. Pat. No. 5,040,715 (Green, et al.); U.S. Pat. No. 5,307,976 (Olson, et al.); U.S. Pat. No. 5,312,023 (Green, et al.); U.S. Pat. No. 5,318,221 (Green, et al.); U.S. Pat. No. 5,326,013 (Green, et al.); and U.S. Pat. No. 5,332,142 (Robinson, et al.).

U.S. Surgical, the assignee of the present application, has manufactured and marketed endoscopic stapling instruments, such as the Multifire ENDO GIA* 30 and Multifire ENDO GIA* 60 instruments, for several years. These instruments have provided significant clinical benefits. Nonetheless, improvements are possible, for example, by reducing the cost and complexity of manufacture.

Current laparoscopic linear stapling devices are configured to operate with disposable loading units (U.S. Surgical) and staple cartridges (Ethicon) of only one size. For example, individual linear staplers are presently available for applying parallel rows of staples measuring 30 mm, 45 mm and 60 mm in length. Thus, during a normal operation, a surgeon may be required to utilize several different stapling instruments to perform a single laparoscopic surgical procedure. Such practices increase the time, complexity and overall costs associated with laparoscopic surgical procedures. In addition, costs are greater in designing and manufacturing multiple stapler sizes, as opposed to creating a single, multi-purpose stapler.

It would be extremely beneficial to provide a surgical device for use during laparoscopic and/or endoscopic surgical procedures that can be employed with several different sized disposable loading units to reduce the overall costs associated with such procedures. It would also be particularly beneficial if the device could perform multiple tasks, using disposable loading units of varying size and of varying purpose, such as, for example, to staple, clip and/or cut.

In making improvements or modifications to the current instruments, it would be highly desirable not to sacrifice any of the important benefits of the MULTIFIRE ENDO GIA* 30 and 60 instruments as compared to other commercially available products, e.g., the endoscopic stapling instruments manufactured and marketed by Ethicon, Inc. For example, any improvement should advantageously provide a fresh knife blade for each firing of the instrument and ensure that the disposable loading unit is securely retained in the stapling instrument unless and until the operating team chooses to remove it. These advantages have historically been found in the U.S. Surgical instruments, but not in the Ethicon instruments.

Therefore, a need exists for a reliable surgical stapler and disposable loading units for use therewith that exhibit all of the benefits of the present assignee's commercially available instruments while also reducing the cost and complexity of manufacture.

SUMMARY

The subject application is primarily directed to a stapling device for applying parallel rows of surgical fasteners to body tissue and, preferably, one that concomitantly forms an incision between the rows of staples during an endoscopic or laparoscopic surgical procedure. A particularly unique feature of the stapling device described herein is that it can be employed with a number of different disposable loading units. Moreover, the stapling device of the subject application can be utilized with disposable loading units configured to apply linear rows of staples measuring from about 15 mm in length to about 60 mm in length.

In a preferred embodiment of the subject surgical stapler, the device includes a handle assembly including an elon-

gated barrel portion and an actuation handle movable through an actuating stroke, and an elongated body extending distally from the barrel portion of the handle assembly and defining a longitudinal axis. An elongated actuation shaft is supported at least in part within the barrel portion of the handle assembly and it has a particular linear dimension. The actuation handle interacts with the actuation shaft such that manipulation of the actuation handle through a complete actuating stroke causes the actuation shaft to translate through a predetermined linear distance.

A disposable loading unit is operatively engaged in a distal portion of the elongated body. The disposable loading unit preferably includes a carrier, a staple cartridge containing a plurality of staples, an actuator (movable through the housing and staple cartridge) and an anvil. The instrument actuation shaft drives the actuator through the staple cartridge to eject the staples against the anvil to form a staple line having a particular linear dimension. Preferably, the linear dimension of the staple line corresponds to the distance through which the actuation shaft translates in response to manipulation of the actuation handle through a particular number of complete or partial actuation strokes numbering more than one complete stroke.

The actuation shaft is preferably defined at least in part by a toothed rack having a particular rack length, and the actuation handle has a pawl member for selectively engaging the toothed rack and advancing the actuation shaft in response to manipulation of the actuation handle. When a disposable loading unit having linear rows of staples is used, the linear dimension of the staple line applied by the stapling unit is preferably proportional to the longitudinal travel of the actuation shaft. In a most preferred embodiment, the minimum linear dimension of the staple line will always be greater than the maximum linear distance through which the actuation shaft translates in response to a complete actuation stroke.

When a disposable loading unit having an anvil is used, the actuation handle is preferably movable through a clamping stroke in which the actuation shaft translates through a predetermined clamping distance to move the anvil from an open position to a closed position. The clamping stroke precedes the first of any number of complete or partial actuation strokes. In a preferred embodiment, an engagement hook is mounted within the barrel portion of the handle assembly to selectively maintain the actuation shaft in a particular position after traveling through the clamping distance and a notch is defined in a distal end portion of the actuation shaft, distal of the toothed rack, for receiving and releasably retaining the engagement hook.

In use of a preferred embodiment, movement of the actuation handle in a direction opposite the clamping stroke causes the engagement hook to release the actuation shaft, permitting the anvil to move to an open position. A lift finger is provided on a flange extending from the actuation handle and is positioned to move the engagement hook out of engagement with the notch when the actuation handle is moved in a direction opposite the clamping stroke. Preferably, a first biasing spring is provided within the handle assembly for biasing the actuation handle in a clockwise direction and a second biasing spring is provided within the handle assembly for biasing the actuation handle in a counter-clockwise direction, about a handle pivot point. The counter-clockwise direction corresponds to the direction of the clamping and actuating strokes.

The engagement hook is preferably configured to interact with the toothed rack to maintain the actuation shaft in a

particular linear position during an actuation stroke, and it is normally biased into engagement with the actuation shaft. An abutment strut or beam is operatively associated with a proximal end portion of the stapler body for maintaining the engagement hook in a position out of engagement with the actuation shaft until a disposable loading unit is operatively engaged in a distal end portion of the elongated body. The abutment strut permits the engagement hook to engage the actuation shaft after a disposable loading unit has been operatively engaged in a distal end portion of the elongated instrument body.

In another preferred embodiment of the surgical stapling apparatus disclosed herein, a release mechanism is operatively associated with the handle assembly for effectuating the manual disengagement of the engagement hook from the actuation shaft to permit subsequent distal advancement of the actuation shaft in response to manipulation of the actuation handle through any number of subsequent stapling strokes. In addition, a retracting mechanism is operatively associated with the handle assembly for effectuating the manual retraction of the actuation shaft at any point in the actuating stroke so that the actuator can be withdrawn to permit the anvil to move from a closed position to an open position.

In a preferred embodiment of the device described herein, the disposable loading unit is adapted to apply linear rows of staples and includes: a carrier having a proximal end portion including a coupling for releasable engagement in a distal end portion of the elongated instrument body; an elongate staple cartridge supported in the carrier and containing a plurality of surgical fasteners and a plurality of fastener pushers for ejecting the fasteners from the staple cartridge; an actuator for contacting the fastener pushers; and an anvil supported on the carrier and mounted for movement with respect to the staple cartridge between an open position and a closed position. The anvil preferably has a fastener forming surface against which the surgical fasteners are driven when ejected from the staple cartridge by the fastener pushers, and a camming surface opposite the fastener forming surface. The actuator is preferably a wedged actuator that translates through the staple cartridge to sequentially interact with the fastener pushers to eject the fasteners from the staple cartridge.

The disposable loading unit further preferably includes an elongated drive beam having a proximal engagement portion, a distal working end portion having an abutment surface and a camming member. The proximal engagement portion is configured to mate with a distal end portion of the actuation assembly of the stapler while the abutment surface engages the actuator to eject staples from the staple cartridge during firing. The camming member contacts the camming surface of the anvil during firing. In use, the stapler actuation assembly moves the drive beam through the carrier causing the camming member to close the anvil or maintain the anvil closed as it substantially simultaneously causes the actuator to translate through the staple cartridge, thereby sequentially interacting with the plurality of fastener pushers to fire the staples.

Preferably, the camming member is defined by a cylindrical cam roller mounted on a flange extending from the distal working end portion of the drive beam. A longitudinal slot is defined in the anvil to accommodate the linear translation of the working end portion of the drive beam, and a transverse support flange is operatively mounted on the working end portion opposite the cam roller to engage an undersurface of the carrier as the cam roller engages the camming surface of the anvil. A longitudinal slot is also defined in the undersur-

face of the carrier to accommodate the linear translation of the working end portion of the drive beam. An optional anvil cover can be provided to ensure tissue is not inadvertently contacted by the drive beam or cam roller during firing.

Preferably, a knife blade is operatively supported adjacent a leading edge of the working end portion of the drive beam for forming an incision in stapled body tissue. Also, the actuator is preferably a sled including a planar base portion and a plurality of spaced apart upstanding cam wedges each having an inclined leading edge for interacting with the fastener pushers within the staple cartridge.

In a preferred embodiment of the stapling device described herein, the distal end portion of the elongated body and the proximal portion of the carrier includes cooperating portions of a bayonet-type coupling. The coupling facilitates the convenient removal and engagement of a variety of different sized disposable loading units including those which are configured to apply staple rows that are approximately 30 mm in length, 45 mm in length, and 60 mm in length. Accordingly, it is envisioned that the device can be sold and marketed as a kit which would include at least one surgical instrument designed to actuate compatible disposable loading units and a plurality of disposable loading units that can vary in size and type. The disposable loading units can be adapted to apply linear rows of staples, clips or other forms of fasteners. A common feature of these disposable loading units is that they utilize the longitudinal motion of the instrument actuation control rod to apply the fasteners.

These and other features of the surgical stapling device of the subject application will become more readily apparent to those skilled in the art from the following detailed description of the preferred embodiments of the device taken in conjunction with the drawings.

BRIEF DESCRIPTION OF THE DRAWINGS

Various embodiments of the surgical stapling apparatus of the subject application will be described hereinbelow with reference to the drawings wherein:

FIG. 1 is a perspective view of a surgical stapling apparatus constructed in accordance with a preferred embodiment of the subject application in conjunction with three different sized disposable loading units each configured for utilization with the stapling apparatus;

FIG. 2 is an exploded perspective view of the handle assembly of the surgical stapling apparatus illustrated in FIG. 1;

FIG. 3 is an exploded perspective view of a disposable loading unit constructed in accordance with a preferred embodiment of the subject application;

FIG. 4 is a perspective view in partial cross-section of the handle assembly and body portion of the stapling apparatus illustrated in FIG. 1 as the disposable loading unit of FIG. 3 is inserted into the distal end of the body;

FIG. 5 is a perspective view which corresponds to the illustration in FIG. 4 with the disposable loading unit mounted in the body of the stapling apparatus and the actuation mechanism within the handle portion enabled as a result of the insertion of the disposable loading unit;

FIG. 6 is a side elevational view of the surgical stapling apparatus of the subject application with the handle portion sectioned to illustrate the relative positions of the components of the actuation assembly housed therein prior to actuation;

FIGS. 7 is a side elevational view of the surgical stapling apparatus of the subject application with the handle portion

sectioned to illustrate the relative positions of the components of the actuation assembly when the actuation handle is partially compressed to move the anvil of the disposable loading unit to a closed position;

FIG. 8 is a side elevational view of the surgical stapling apparatus of the subject application with the handle portion sectioned to illustrate the relative positions of the components of the actuation assembly when the actuation handle is released to permit the anvil of the disposable loading unit to move to an open position;

FIG. 9 is a side elevational view of the surgical stapling apparatus of the subject application with the handle portion sectioned to illustrate the relative positions of the components of the actuation assembly when the actuation handle is moved to a position wherein the anvil of the disposable loading unit is maintained in an open position;

FIG. 10 is a side elevational view of the surgical stapling apparatus of the subject application with the handle portion sectioned to illustrate the relative positions of the components of the actuation assembly when the actuation handle is manipulated through one complete actuation stroke to apply a portion of the staples from the staple cartridge of the disposable loading unit to body tissue;

FIG. 11 is a side elevational view of the surgical stapling apparatus of the subject application with the handle portion sectioned to illustrate the relative positions of the components of the actuation assembly when the disposable loading unit is removed from the distal end of the stapler body;

FIG. 12 is a side elevational view of the disposable loading unit of the subject application with the body thereof sectioned to illustrate the relative positions of the components prior to closing the anvil to clamp a tubular vessel;

FIG. 13 is a side elevational view of the disposable loading unit of the subject application with the body thereof sectioned to illustrate the relative positions of the components after the apparatus has been completely fixed;

FIG. 14 is a side elevational view of the disposable loading unit as illustrated in FIG. 13 with the anvil moved to an open position under the bias of a release spring;

FIG. 15 illustrates an alternate embodiment of a disposable loading unit adapted to apply surgical clips;

FIG. 16 illustrates an alternate embodiment of a disposable loading unit adapted to apply single surgical staples;

FIG. 17 is a perspective view of another surgical stapling apparatus constructed in accordance with a preferred embodiment of the subject invention illustrated in conjunction with one of several different sized disposable loading units employed with the apparatus;

FIG. 18 is an exploded perspective view of the handle assembly of the surgical stapling apparatus of FIG. 17 with the components associated therewith separated for ease of illustration;

FIG. 19 is an exploded perspective view of the body portion of the surgical stapling apparatus of FIG. 17 in conjunction with the elongated control rod which extends there-through;

FIG. 20 is a perspective view of a distal portion of the control rod illustrated in FIG. 19;

FIG. 21 is a cross-sectional view taken along line 21—21 of FIG. 19 illustrating the proximal portion of the inner support tube housed within the body portion of the surgical stapling apparatus of FIG. 17;

FIG. 22 is a side elevational view in partial cross-section of the surgical stapling apparatus of FIG. 17 illustrating the

orientation of the rack lock prior to mounting the disposable loading unit in the distal end of the body portion;

FIG. 23 is a side elevational view in partial cross-section of the surgical stapling apparatus of FIG. 17 illustrating the orientation of the rack lock after the disposable loading unit has been mounted in the distal end of the body portion;

FIG. 24 is an exploded perspective view of a disposable loading unit constructed in accordance with a preferred embodiment of the subject invention which includes a lockout assembly that functions to limit the longitudinal translation of the control shaft illustrated in FIGS. 19 and 20;

FIG. 25 is an enlarged exploded perspective view of the lockout assembly illustrated in FIG. 24 with a distal portion of the control rod;

FIG. 26 is a side elevational view in partial cross-section of a proximal portion of the disposable loading unit of FIG. 24 as it is inserted into the distal end of the body portion with the lockout assembly disposed in a pre-actuated condition;

FIG. 27 is a side elevational view in partial cross-section of the proximal portion of the disposable loading unit of FIG. 24 when the mounting portion thereof is fully inserted into the distal end of the body portion;

FIG. 28 is a side elevational view in partial cross-section of the proximal portion of the disposable loading unit of FIG. 24 as it is rotated into an operational position;

FIG. 29 is a cross-sectional view taken along line 29—29 of FIG. 26 illustrating the alignment of the notches in the head of the control rod and the engagement fingers at the proximal end of the axial drive assembly;

FIG. 30 is a cross-sectional view taken along line 30—30 of FIG. 28 illustrating the position of the head of the control rod in relation to the engagement fingers after the disposable loading unit has been rotated into an operational position;

FIG. 31 is a side elevational view in partial cross-section of the surgical stapling apparatus of FIG. 17 prior to a stapling procedure with the anvil in an open position and the actuation shaft and toothed rack disposed in a proximal-most position within the handle assembly;

FIG. 32 is a side elevational view in partial cross-section of the surgical stapling apparatus of FIG. 17 illustrating the actuation shaft and toothed rack advanced distally through a clamping stroke to effectuate the movement of the anvil from the open position shown in FIG. 31 to a closed position;

FIG. 33 is a side elevational view in partial cross-section of the surgical stapling apparatus of FIG. 17 illustrating the disengagement of the rack lock and pawl from the actuation shaft and toothed rack by the retraction mechanism to effectuate the movement of the anvil from the closed position shown in FIG. 32 to an open position;

FIG. 34 corresponds to FIG. 32 and illustrates the surgical stapling apparatus with the anvil in a closed position after the actuation handle has been manipulated through a clamping stroke;

FIG. 35 is a side elevational view in partial cross-section of the surgical stapling apparatus of FIG. 17 illustrating the manual release of the rack lock to permit distal translation of the actuation shaft during subsequent stapling strokes;

FIG. 36 is a side elevational view in partial cross-section of the surgical stapling apparatus of FIG. 17 illustrating the actuation shaft and toothed rack advanced distally in response to a complete stapling stroke of the actuation handle to effectuate partial subsequent ejection of staples from the cartridge;

FIG. 37 is a side elevational view in partial cross-section of the surgical stapling apparatus of FIG. 17 illustrating the

actuation shaft and toothed rack advanced distally in response to a second complete stapling stroke of the actuation handle to complete the sequentially ejection of the staples from the cartridge;

FIG. 38 is a side elevational view in partial cross-section of the surgical stapling apparatus of FIG. 17 illustrating the disengagement of the rack lock and pawl from the toothed rack by the release plate as the retraction knobs are pulled proximally to withdraw the actuation shaft and permit the anvil to move from the closed position shown in FIG. 37 to an open position;

FIG. 39 is an enlarged side elevational view of the toothed rack and the release plate associated therewith illustrating the rack lock engaged in the toothed rack;

FIG. 40 is an enlarged side elevational view of the toothed rack and the release plate associated therewith illustrating the release plate moved to disengage the rack lock from the toothed rack;

FIG. 41 is a cross-sectional view taken along line 41—41 of FIG. 39;

FIG. 42 is a cross-sectional view taken along line 42—42 of FIG. 40;

FIG. 43 is an enlarged perspective view of the rack lock (or engagement member) illustrating the structural geometry thereof;

FIG. 44 is a side elevational view in partial cross-section of the disposable loading unit illustrating the position of the axial drive assembly and control rod at the conclusion of a stapling procedure;

FIG. 45 is a side elevational view in partial cross-section of the disposable loading unit of FIG. 24 with the components of the lockout assembly illustrated in a position corresponding to the control rod being withdrawn toward a post-fired proximal position;

FIG. 46 is a side elevational view in partial cross-section of the disposable loading unit of FIG. 24 illustrating the orientation of the lockout assembly components as the control rod approaches its proximal-most position;

FIG. 47 is a side elevational view in partial cross-section of the disposable loading unit of FIG. 24 illustrating the orientation of the lockout assembly components when the control rod has been withdrawn to its proximal-most position;

FIG. 48 is a side elevational view in partial cross-section of the disposable loading unit of FIG. 24 illustrating the orientation of the lockout assembly components when the loading unit has been moved distally with respect to the body portion to disengage the bayonet connection;

FIG. 49 is a side elevational view in partial cross-section of the disposable loading unit of FIG. 24 disengaged from the distal end of the body portion at the conclusion of a stapling procedure with the components of the lockout assembly illustrated in a blocking position to prevent subsequent utilization of the loading unit;

FIG. 50 is a cross-sectional view taken along line 50—50 of FIG. 46 illustrating the relative positions of the blocking plate and control rod prior to the removal of the disposable loading unit from the distal end of the body portion; and

FIG. 51 is an enlarged perspective view in partial cross-section of the disposable loading unit after it has been removed from the distal end of the body portion illustrating the lockout assembly in a blocking position to prevent entry of the distal end of the control rod into the drive block of the axial drive assembly.

DETAILED DESCRIPTION OF PREFERRED EMBODIMENTS

In the drawings and in the description which follows, the term “proximal”, as is traditional, will refer to the end of the

stapling apparatus which is closest to the operator, while the term "distal" will refer to the end of the apparatus which is furthest from the operator.

Referring now to the drawings wherein like reference numerals identify similar structural elements of the subject invention, there is illustrated in FIG. 1 a surgical apparatus constructed in accordance with a preferred embodiment of the subject application and designated generally by reference numeral 10. In brief, surgical apparatus 10 is a surgical stapling apparatus configured to engage body tissue, apply a plurality of surgical fasteners thereto, and form an incision in the fastened body tissue during a laparoscopic surgical procedure. Apparatus 10 can also be used to apply surgical clips and other fasteners (discussed in greater detail below) but will be primarily discussed in the context of applying parallel rows of staples from a staple cartridge disposed in a disposable loading unit.

Surgical apparatus 10 is unique among laparoscopic devices known in the art because it can employ a plurality of different sized disposable loading units. Moreover, apparatus 10 is preferably configured to operate with individual disposable loading units that apply linear rows of staples measuring 30 mm, 45 mm, or 60 mm in length (FIG. 1) or apply other types of fasteners (FIGS. 15 and 16). Thus, during a laparoscopic surgical procedure, a single instrument can be utilized with a plurality of interchangeable disposable loading units to perform several tasks. The preferred embodiments discussed in detail primarily relate to disposable loading units adapted to apply linear rows of staples.

As illustrated in FIG. 1, surgical apparatus 10, has a handle assembly 12 and an elongated body 14. Apparatus 10 is adapted for use with disposable loading units 30, 45 and 60 each of which has a carrier 32, a staple cartridge 34, and an anvil 36 against which staples are driven when ejected from their housing. The following specification will provide a detailed description of the construction and operation of the apparatus and disposable loading units for use therewith.

Referring to FIG. 2, handle assembly 12 includes a housing 20 defined by an elongated barrel portion 22, a stationary handle 24 depending from the barrel portion, and an actuation handle 26 which is pivotably mounted to the barrel portion and movable with respect to the stationary handle. Actuation handle 26 is supported within housing 20 by a pivot pin 28 and is biased against counter-clockwise movement by a coiled torsion spring 38.

Actuation handle 26 controls the linear movement of actuation shaft 40 which is mounted within barrel portion 22. More particularly, actuation shaft 40 has a toothed rack 42 defined thereon, and actuation handle 26 has a ratcheting pawl 44 mounted thereto for incrementally engaging and advancing actuation shaft 40. Pawl 44 is mounted on a pivot pin 46 and a coiled torsion spring 48 biases the pawl into engagement with toothed rack 42. A linear biasing strut 50 is supported within barrel portion 22 and is biased distally by a coiled compression spring 52 to bias the pawl, and hence the actuation handle, against clockwise rotation about pivot pin 28. Biasing strut 50 also serves to act on an angled rear cam surface on pawl 44 wherein contact of the cam surface with strut 50 causes pawl 44 to rotate clockwise (away from rack 42). When the instrument is at rest, pawl 44 is biased away from the toothed rack 42. When actuation handle 26 is pulled proximally, pawl 44 moves away from strut 50 and rotates counterclockwise and engages the teeth of actuation shaft 40, thereby allowing actuation handle 26 to drive the shaft distally.

Actuation shaft 40 is normally biased in a proximal direction within barrel portion 22 by a constant force spring 54

which is mounted to the actuation shaft adjacent the distal end thereof by conventional fastening means known in the art. Constant force spring 54 is supported on a boss 56 provided within the housing 22 of handle assembly 12. The distal end portion of actuation shaft 40 has a cavity 58 defined in an undersurface thereof for engaging and retaining the flanged proximal end 62 of control rod 64. Control rod 64 extends coaxially through the elongated body 14 of surgical stapler 10 to interact with a disposable loading unit at a distal end thereof. Thus, linear advancement of actuation shaft 40 in response to manipulation of actuation handle 26 causes corresponding longitudinal movement of control rod 64, and, as will be discussed in detail hereinbelow, actuation of an associated disposable loading unit.

With continuing reference to FIG. 2, the proximal end portion of the elongated body 14 of surgical stapler 10 has an annular flange 66 formed thereon which engages a corresponding annular recess 68 formed within the barrel portion 22 adjacent the distal end thereof to fixedly attach the two structural members. The engagement of flange 66 within recess 68 facilitates rotational movement of body portion 14 with respect to the barrel portion 22 about a longitudinal axis which extends therethrough. A collar 70 is fixedly mounted to the proximal portion of stapler body 14 by a pair of opposed protuberances 72 and 74. Thus, rotation of collar 70 will cause corresponding rotation of body portion 14 to increase the range of operability of surgical stapler 10.

Within handle assembly 12, there is also contained a mechanism for initiating the engagement between a rack lock 80 and the toothed rack 42 of actuation shaft 40. Rack lock 80 maintains the longitudinal position of actuation shaft 40 under the bias of constant force spring 54. Rack lock 80 will not engage the rack unless and until a disposable loading unit is operatively engaged in the distal end portion of portion body 14. This mechanism is illustrated in FIG. 2 and its interaction with rack lock 80 is best understood by also referring to FIGS. 4 and 5. The mechanism includes an elongate beam or strut 82 having a distal tang 84 that engages a keeper notch 86 formed adjacent the proximal end of a support tube 88 that is slidably mounted within stapler body 14. Beam 82 has a medial hook 90 for engaging the proximal end of a coiled biasing spring 92, the distal end of which is mounted on a boss 94 provided within barrel portion 22. Biasing spring 92 biases beam 82, and hence support tube 88, against proximal movement. An arcuate cam finger 96 projects proximally from beam 82 for interacting with an angled cam surface 98 defined on the undersurface of the body 100 of rack lock 80. Rack lock 80 further includes a wedged clasp portion 102 which is dimensioned and configured to engage the teeth of the toothed rack 42 to maintain the longitudinal position of actuation shaft 40 during the operation of instrument 10. The body 100 of rack lock 80 is mounted on a boss 104 provided within the barrel portion 22 of housing 20. A coiled torsion spring 106 is also mounted on boss 104 and is connected to body 100 to bias the rack lock into engagement with toothed rack 42.

As best seen in FIGS. 4 and 5, when the proximal end portion of the carrier 32 of disposable loading unit 30 is inserted into the distal end of elongated body 14, support tube 88 is urged in a proximal direction against the bias of spring 92. Thereupon, beam 82 translates proximally and the arcuate cam finger 96 contacts angled cam surface 98, lifting rack lock 80 and causing it to rotate in a counter-clockwise direction against the bias of torsion spring 106. At such a time, the cam finger 96 of beam 82 is accommodated within a recess 108 formed in the body 100 of rack lock 80. With the rack lock in this position, it will engage actuation shaft

40 when it is advanced distally upon manipulation of actuation handle 26. The interaction of rack lock 80 and actuation shaft 40 will be discussed in greater detail hereinbelow with respect to the manner in which instrument 10 is operated to clamp body tissue and apply fasteners thereto.

Referring now to FIG. 3, an exemplary disposable loading unit is illustrated and is designated generally by reference numeral 30. As noted hereinabove, disposable loading unit 30, which is particularly adapted to apply a plurality of linear rows of staples measuring about 30 mm in length, is one of several different size or type of disposable loading units that can be utilized with instrument 10 during a surgical procedure. The carrier 32 of stapling unit 30 includes an elongate channel 110 having a base 112 and two parallel upstanding walls 114 and 116 which include several mounting structures for supporting staple cartridge 34 and anvil 36. Carrier 32 also includes mounting portion 120 which is mounted to the proximal portion of channel 110 through the engagement of a plurality of spaced apart rectangular tangs 122 and a plurality of corresponding slots 124 formed in the opposed walls 114 and 116 of channel 110. The proximal end section 126 of mounting portion 120 is dimensioned and configured for insertion into the distal end portion of elongated body 14, and it is provided with an axial bore 125 for accommodating the distal end of control rod 64.

A coupling stem 128 projects radially outwardly from end section 126 for interacting with the J-shaped coupling slot 130 defined in the wall of the distal end portion of elongated body 14 (see FIGS. 4 and 5). Stem 128 and slot 130 together define a conventional bayonet-type coupling which facilitates quick and easy engagement and removal of the stapling unit from the stapler during a surgical procedure. Once engaged in the distal end portion of stapler elongated 14, the distal end of support tube 88 urges proximal end section 126 distally under the bias of coiled spring 92, thereby maintaining the coupling stem 128 within coupling slot 130.

With continuing reference to FIG. 3, the distal portion of channel 110 supports staple cartridge 34 which contains a plurality of surgical fasteners 132 and a plurality of corresponding ejectors or pushers 134 that drive the fasteners from cartridge 34 under the influence of a fastener driving force exerted by actuation sled 140. Staple cartridge 34 is maintained within channel 110 by lateral struts 136 which frictionally engage the upper surfaces of channel walls 114 and 116, and the frictional engagement of housing tabs, such as tab 138, within notches 139. These structures serve to restrict lateral, longitudinal, an elevational movement of the staple cartridge 34 within channel 110.

A plurality of spaced apart longitudinal slots 142 extend through staple cartridge 34 to accommodate the upstanding cam edges 144 of actuation sled 140. Slots 142 communicate with a plurality of transverse retention slots 146 within which the plurality of fasteners 132 and pushers 134 are respectively supported. During operation, as actuation sled 140 translates through staple cartridge 34, the angled leading edges of cam wedges 144 sequentially contact pushers 136, causing the pushers to translate vertically within slots 146, urging the fasteners 134 therefrom. The result of the interaction between actuation sled 140 and pushers 136 is illustrated in FIGS. 12-14, and will be described hereinbelow with reference thereto. See also, commonly assigned U.S. Pat. No. 4,978,049 to Green, the disclosure of which is herein incorporated by reference in its entirety.

With continuing reference to FIG. 3, the anvil 36 of disposable loading unit 30 is provided with opposed mounting wings 150 and 152 which are dimensioned and configured to

engage pivot apertures 154 and 156 in channel walls 114 and 116, respectively. A biasing member 158 having spring arms 158a and 158b is secured to the proximal end of anvil 36. The spring arms bear against internal bearing surfaces defined within mounting portion 120 to bias anvil 36 into a normally open position wherein the interior fastener forming surface 155 thereof is spaced from staple cartridge 34.

Disposable loading unit 30 further includes an axial drive assembly 160 for transmitting the longitudinal drive forces exerted by control rod 64 to actuation slot 140 during a stapling procedure. Drive assembly 160 includes an elongated drive beam 162 including a distal working head 164 and a proximal engagement section 166. Engagement section 166 includes a pair of engagement fingers 166a and 166b which are dimensioned and configured to mountably engage a pair of corresponding retention slots 168a and 168b formed in a drive block 168. Drive block 168 has a proximal porthole 170 for receiving the distal end of control rod 64 when the proximal end of stapling unit 30 is inserted into the distal end of stapler body 14. Drive block 168 can be provided with an internal slot to receive a stem (not shown) from a distal end of control rod 64 to form a bayonet type connection, similar to that shown in connecting elongated body 14 to coupling stem 128. Such a connection would enable the user to manipulate drive beam 162 upon movement of control rod 64. The working end 164 of drive beam 162 is defined by a vertical support strut 172 which supports a knife blade 174, and an abutment surface 176 which engages the central support wedge 145 of actuation sled 140. Knife blade 174 travels slightly behind actuation sled 140 during a stapling procedure to form an incision between the rows of staple body tissue. A retention flange 178 projects distally from vertical strut 172 to retain a cylindrical cam roller 180. Cam roller 180 is dimensioned and configured to engage and translate with respect to the exterior camming surface 182 of anvil 36 to progressively clamp the anvil against body tissue during firing.

A longitudinal slot 184 extends through anvil 36 to accommodate the translation of retention flange 178 and vertical strut 172. A balancing flange 186 is secured to the working end of drive beam 162 through the engagement of retention foot 188 within a complementary retention port 190 formed in flange 186. Flange 186 serves to balance the clamping forces generated by cam roller 180 as anvil 36 is progressively clamped. A longitudinal slot 192 is formed in the base 112 of channel 110 to accommodate the longitudinal translation of retention foot 188 during firing.

With reference to disposable loading unit 45 in FIG. 1, an anvil cover is provided to protect tissue from moving parts along the exterior of anvil 36. In particular, anvil cover 400 has channel 402 formed on an underside thereof and is secured to an upper surface of anvil 36 to form a channel therebetween. Cam roller 180 travels in channel 402 between cover 400 and anvil 36 during firing. Anvil cover 400 is preferably plastic, but can be fabricated from any suitable biocompatible material.

Returning to FIG. 3, a dual constant force spring members 194 and 196 are connected to the proximal end of channel base 112 and are disposed distal of drive block 168 to bias the block against distal movement. As best seen in FIGS. 12-14, when drive block 168 translates distally, spring members 194 and 196 unwind until they are passed over by the block at the end of its travel. At such a time, the spring members return to their normally wound position providing a buffer for the mounting block. Thus, an attempt to return the block to the proximal most position after firing the disposable loading unit will be inhibited.

Referring now in sequential order to FIGS. 4–11, to initiate the operation of instrument 10, a desired disposable loading unit is selected. Such disposable loading unit can be one of the different sized disposable loading units illustrated in FIG. 1 or one of the disposable loading units adapted to apply surgical clips (FIG. 15) or other types of surgical staples (FIG. 16). Use of the instrument will be discussed herein using a disposable loading unit adapted to apply linear rows of staples. Disposable loading unit 30, is mounted to the stapler by inserting the proximal mounting section thereof into the distal end of the elongated body 14, as shown in FIG. 4. Prior to insertion, support tube 88 is in its distal-most position within elongated body 14 and it is maintained in that position by spring 92. Accordingly, the cam finger 96 of beam 82 maintains rack lock 80 in a disengaged uplifted position, spaced from the toothed rack 42 of actuation shaft 40.

Once the proximal end of the disposable loading unit is inserted into the distal end of elongated body 14, it is rotated approximately 10° to 15° to position coupling stem 128 in the base of coupling slot 130. Thereupon, the bias of spring 92 urges support tube 80 distally to lock stem 128 within the base of slot 130. If a coupling system is provided between control rod 64 and drive block 168 (discussed above) such rotation would couple these member as well. In addition, as illustrated in FIG. 5, when support tube 88 is shifted proximally by the insertion of the proximal section 126 of mounting portion 120 into elongated body 14, arcuate cam finger 96 of beam 82 translates proximally against cam surface 98 until it reaches recess 108. Thereupon rack lock 80 moves into an engagement position under the bias of torsion spring 106, and instrument 10 is ready for use.

Turning to FIG. 6, prior to utilization, actuation handle 26 is in the illustrated neutral position. In this position, pawl 44 is spaced from the toothed rack 42 of actuation shaft 40. In addition, lift arm 210 which projects distally from actuation handle 26 is engaged beneath a transverse finger 212 formed at the proximal end of rack lock 80 adjacent the wedged clasp portion 102. Lift arm 210 serves to disengage clasp portion 102 from actuation shaft 40 under certain operating conditions which will be discussed hereinbelow with respect to FIGS. 8 and 9.

Prior to manipulating actuation hook 26, actuation shaft 40 is in its proximal-most position, as is control rod 64, biased against distal movement by constant force spring 54. Accordingly, anvil 36 is in an open position biased against closure by spring arms 158a and 158b. Thus, at such a time, body tissue such as tubular vessel 200 may be captured between the fastener forming surface of anvil 36 and the tissue contacting surface of staple cartridge 34.

Turning now to FIG. 7, manipulation of actuation handle 26 in the direction indicated by reference arrow "A" causes pawl 44 move distally and rotate counterclockwise to engage toothed rack 42 and drive actuation shaft 40 distally against the bias of spring 54. As a result, control rod 64 is driven distally, forcing drive block 168 forward within disposable loading unit 30. Accordingly, a working end 164 of drive beam 162 translates distally and cam roller 180 engaged the proximal end portion of the cam surface of anvil 36, causing the anvil to move into a closed position, clamping tubular vessel 200 against the tissue contacting surface of staple cartridge 34. In addition, when actuation shaft 40 advances distally, the clasp portion 102 of rack lock 80 engages a notched area 214 formed in the distal end portion of actuation shaft 40 distal of toothed rack 42 under the bias of torsion spring 106. Thereupon, the longitudinal position of actuation shaft 40 within barrel portion 22 is maintained, and anvil 36 is locked in a closed position.

Under certain circumstances it may be necessary to open the anvil and unclamp the captured vessel or body tissue, i.e., to recapture the vessel at a different location. As illustrated in FIG. 8, to release the anvil, actuation handle 26 is manipulated in the direction indicated by reference arrow "B" against the bias of linear compression spring 52. As a result, arm 210 lifts finger 212, rotating rack lock 80 in a counterclockwise direction against the bias of torsion spring 106, as shown in FIG. 9. The clasp portion 102 of rack lock 80 is thereby disengaged from notched area 214, permitting actuation shaft 40 and control rod 64 to return to their proximal-most positions. At such a time, a drive block 168 moves proximally under the bias of spring members 194 and 196. Accordingly, cam roller 180 is drawn off of the exterior camming surface 182 of anvil 36, and the anvil moves to an open position under the bias of spring member 158. Subsequent anvil closure is achieved in the manner described hereinabove with reference to FIG. 7.

Referring to FIG. 10, to fire instrument 10 and apply a plurality of surgical fasteners 132 to the tissue clamped between anvil 36 and staple cartridge 34, actuation handle 26 is manipulated toward stationary handle 24 in the direction indicated by reference arrow "C" against the bias of torsion spring 38. Thereupon, pawl 44 engages toothed rack 42 and drives actuation shaft 40 distally against the bias of constant force spring 54. In a preferred embodiment of firing a disposable loading unit having linear rows of staples, one complete stroke of actuation handle 26 causes actuation shaft 40 to advance approximately 15 mm within barrel portion 22, urging drive beam 162 an equivalent distance within disposable loading unit 30 as control shaft 64 transmits longitudinal motion thereto. As a result, half of the surgical fasteners 132 within 30 mm staple cartridge 34 are ejected therefrom upon moving actuation handle 26 one complete stroke. Actuation shaft 40 is maintained in this longitudinally advanced position through the engagement of the clasp portion 102 of rack lock 80 and the toothed rack 42. Subsequent release and movement of actuation handle 26 to a relaxed position will therefore have no bearing on the longitudinal position of actuation shaft 40.

To complete the staple firing operation, actuation handle 26 is once again approximated toward stationary handle 24, causing pawl 44 to engage toothed rack 42 and advance actuation shaft 40 in a distal direction another 15 mm. Thus, two complete strokes of actuation handle 26 causes actuation shaft 40 to advance 30 mm within barrel portion 22, urging the working end 164 to drive beam 162 through staple cartridge 34 to sequentially eject all of the surgical fasteners therefrom. If desired, the operator can incrementally advance control shaft 64 by multiple short strokes, wherein the minimum advancement is dictated by the linear distance between the teeth on rack 42. Therefore, while two complete strokes of the preferred stroke distance of 15 mm can be used (to fire a 30 mm disposable loading unit), complete strokes are not necessary or required.

As best seen in FIGS. 12–14, two complete strokes of actuation handle 26 causes actuation shaft 40 and the associated control rod 64 to translate from the proximal-most position illustrated in FIG. 12, wherein drive block 168 is disposed adjacent the proximal end of channel 110, to the distal-end position illustrated in FIG. 13, wherein drive block 168 travels to the distal end of staple cartridge 34. During its travel, drive block 168 urges drive beam 166 distally, effectuating progressive closure of anvil 36 against tubular vessel 200, and sequential ejection of surgical fasteners 132 into the body tissue as actuation sled 140 travels through staple cartridge 34. As shown in FIG. 13, when cam

roller 180 reaches the distal end of its travel, it drops back into the transverse slot 185 formed at the distal end of anvil slot 184. As a result, anvil 36 returns to open position under the bias of spring member 158, releasing the stapled body tissue as illustrated in FIG. 14. Furthermore, spring members 194 and 196 rewind and return to a coiled condition at the proximal end of channel 110.

At the conclusion of the above-described firing operation, disposable loading unit 30 is removed from the distal end of elongated body 14, as illustrated in FIG. 11. At such a time, support tube 88 is permitted to return to its distal-most position under the bias of spring 92. Accordingly, beam 82 translates distally causing arcuate cam finger 96 to lift rack lock 80 out of engagement with the toothed rack 42 of actuation shaft 40. As a result, actuation shaft 40 returns to its proximal-most position within barrel portion 22 under the bias of constant force spring 54. Thereupon, a new disposable loading unit can be joined with the instrument and another surgical task performed.

If the surgeon desires to apply parallel rows of staples each measuring about 45 mm in length, disposable loading unit 45 (FIG. 1) is mounted to the distal end portion of elongated body 14. After mounting, actuation handle 26 is manipulated through a number of strokes equalling three complete actuation strokes to incrementally advance actuation shaft 40 and control rod 64 a distance of 45 mm. Alternatively, if disposable loading unit 60 is selected for utilization to apply staple rows measuring about 60 mm in length, actuation handle 26 must be manipulated through a number of strokes equalling four complete actuation strokes to incrementally advance actuation shaft 40 and control rod 64 a distance of 60 mm.

Turning to FIGS. 15 and 16, two alternate embodiments of disposable loading units are shown. Disposable loading unit 410 in FIG. 15 is designed to apply surgical clips. Disposable loading unit 410 has jaw structure 412 and a plurality of clips disposed in housing 44. Commonly assigned U.S. Pat. No. 5,100,420, the disclosure of which is herein incorporated by reference in its entirety, discloses a manner in which clips can be fed to jaw structure 412 and formed. Disposable loading unit 420 in FIG. 16 is designed to apply individual surgical staples, such as those useful during hernia repair. Disposable loading unit 420 has jaw structure 422 and a plurality of staples disposed in housing 424. Commonly assigned U.S. Pat. No. 5,289,963, the disclosure of which is herein incorporated by reference in its entirety, discloses a manner in which staples can be fed to jaw structure 422 and formed. Both disposable loading units 410 and 420 are secured to the surgical instrument in a manner similar to the disposable loading units previously described and are actuated by the longitudinal motion of actuation shaft 40 and control rod 64.

It is readily apparent and may be appreciated by those having ordinary skill in the art that the stroke distance travelled by the actuation shaft may be adjusted in accordance with desired surgical practices. For example, it may be desirable to employ disposable loading units which apply parallel staple rows measuring 40 mm, 60 mm, or 80 mm. Thus, the incremental stroke distance travelled by the actuation shaft could be adjusted to approximately 20 mm intervals. In addition, one skilled in the art could provide alternate structure or orientation of structures to control the advancement of control rod 64. For example, toothed rack 42 could be rotated so the teeth face downward towards the handles and the locks and pawls moved to engage the rack from the underside. Also, various safety mechanisms can be added, such as a lockout in the handle that needs to be released prior

to actually firing a disposable loading unit. These and other features are described in greater detail, below.

Referring now to FIG. 17, there is illustrated another surgical stapling apparatus constructed in accordance with a preferred embodiment of the subject application and designated generally by reference numeral 500. AS in the previously described embodiment, surgical stapling apparatus 500 is configured to engage body tissue, apply a plurality of surgical fasteners thereto, and form an incision in the fastened body tissue during a laparoscopic surgical procedure. The apparatus is preferably configured to operate with individual disposable loading units that apply linear rows of staples measuring 30 mm, 45 mm, or 60 mm in length (see generally FIG. 1), or other types of disposable loading units (see, generally FIGS. 15 and 16).

As illustrated in FIG. 17, surgical stapler 500 has a handle assembly 512 and an elongated body 514, and is adapted for use with a disposable loading unit 530, among other units not shown, which has a carrier 532, a staple cartridge 534, and an anvil 536 against which staples are driven when ejected from the cartridge.

Referring to FIG. 18, as in the previous embodiment, handle assembly 512 includes a housing 520 defined by a barrel portion 522, a stationary handle 524, and a pivoting actuation handle 526. Actuation handle 526 is supported in housing 520 by pivot pin 528 and is biased away from stationary handle 524 by a torsion spring 538. Actuation handle 526 controls the linear movement of actuation shaft 540 which is supported within the barrel portion 522 of housing 520. More particularly, actuation shaft 540 has a toothed rack 542 defined on an undersurface thereof and actuation handle 526 is provided with a pawl 544 which is mounted to selectively engage toothed rack 542 and advance the actuation shaft 540 in a distal direction in response to manipulation of actuation handle 526 through an actuating stroke. Pawl 544 is mounted to actuation handle 526 by a pivot pin 546 and is biased toward toothed rack 542 by a coiled torsion spring 548. The mounting portion of pawl 544 is curved to interact with an abutment wall 545 defined within the housing 520 of handle assembly 512. More particularly, when the curved mounting portion of pawl 544 contacts abutment wall 545, the pawl is rotated out of engagement with the toothed rack 542 of actuation shaft 540.

Actuation shaft 540 is normally biased in a proximal direction within barrel portion 522 by a constant force spring 554 which is supported on a boss 556 provided within housing 520. A notched area 555 is formed in the upper surface of actuation shaft 540 adjacent the proximal end thereof for receiving and retaining an engagement tab 557 provided at the free end of constant force spring 554. The distal end of actuation shaft 540 is provided with a catchment fitting 558 for engaging the flanged proximal end 564p of control rod 564. Control rod 564 extends from the handle assembly 512 through the elongated body portion 514 to interact with the disposable loading unit 530 supported at the distal end of the body portion. Accordingly, manipulation of actuation handle 526 causes corresponding longitudinal translation of the actuation shaft 540 and control rod 564 to actuate the disposable loading unit in a manner which will be discussed in detail hereinbelow.

With continuing reference to FIG. 18, the proximal end of the elongated body portion 514 of surgical stapler 500 has an annular flange 566 formed thereon which is received in a corresponding annular recess 568 formed within the barrel portion 522 adjacent the distal end thereof. This connection facilitates rotational movement of body 514 relative to

handle assembly 512 about a longitudinal axis extending therethrough. A collar 570 is fixedly mounted to body portion 514 by at least one protuberance 572 to effectuate the axial rotation of body portion 514 and thereby increase the operational range of surgical stapler 500.

As in the previously described embodiment, surgical stapler 500 includes a rack lock (or engagement member) 580 which interacts with the toothed rack 542 of actuation shaft 540 to selectively maintain the longitudinal position thereof within barrel portion 522 against the bias of constant force spring 554. Rack lock 580 is mounted in such a manner so as to move into a position to interact with toothed rack 542 only when a disposable loading unit has been inserted into the distal end of body portion 514. More particularly, rack lock 580, which is mounted on a pivot pin 583 and biased toward the toothed rack 542 by a coiled torsion spring 585, is maintained in a non-interactive position by an abutment strut 582 until a disposable loading unit is loaded into the device. Abutment strut 582 is mounted on a securement flange 586 formed at the proximal end of a support tube 588 which is mounted for axial translation within body portion 514 (see FIG. 21). A coiled biasing spring 592 connects abutment strut 582 to a boss 593 in the housing 520 of handle assembly 512, and, in effect, biases the support tube 588 in a distal direction so that upon insertion of a disposable loading unit, support tube 588 and abutment strut 582 are shifted in a proximal direction.

More specifically, as illustrated in FIG. 22, prior to insertion of loading unit 530, an arcuate camming finger 596 which projects proximally from abutment strut 582 is in contact with a distal portion of an angled camming surface 598 defined on rack lock 580. At such a time, rack lock 580 is maintained in a non-interactive position against the bias of coiled torsion spring 585. Thereafter, as shown in FIG. 23, when loading unit 530 is inserted into the distal end of body portion 514 and rotated to engage the bayonet connection associated therewith (stems 628a and 628b, slots 630a and 640b), support tube 588 and abutment strut 582 are urged proximally against the bias of coiled spring 592 (and coiled spring 597). As a result, the proximal camming finger 596 translates in a proximal direction along camming surface 598, permitting rack lock 580 to rotate about pin 583 under the bias of torsion spring 585 into an interactive position in which the toothed rack 542 of actuation shaft 540 may be engaged upon the distal translation thereof.

As illustrated in FIGS. 22 and 23, a second abutment strut 584 is disposed opposite abutment strut 582 and is connected to the proximal end of support tube 588 in the same manner as abutment strut 582. Abutment strut 584, and the spring 597 which is associated therewith and connected to housing 520 by boss 591, provide additional biasing force to securely maintain the bayonet connection between the disposable loading unit 530 and the body portion 514.

Referring to FIG. 19, an elongated slot 602 extends along a portion of support tube 588 and a transverse groove 604 extends along the axial bore 606 of body portion 514 to accommodate a support pin 608 which extends radially outwardly from the central portion of control rod 564. This connection permits longitudinal movement of support tube 588 with respect to body portion 514 and control rod 564 while maintaining the respective angular orientation of the three coaxial structures to facilitate their axial rotation by collar 570.

Turning now to FIG. 24, there is illustrated disposable loading unit 530 which is constructed in a manner that is substantially similar to the loading unit illustrated in FIG. 3.

It includes a carrier 532 having an elongated support channel 610 for supporting staple cartridge 534 and anvil 536 and a mounting portion 620 which is configured for releasable engagement in the distal end of body portion 514. More particularly, the proximal end portion 626 of mounting portion 620 is provided with a pair of coupling stems 628a and 628b which interact with the J-shaped coupling slots 630a and 630b formed at the distal end of body portion 514 (see, for example, FIG. 26). The coupling stems and J-shaped slots together define the conventional bayonet-type coupling which facilitates the engagement and removal of the loading unit from the stapler. As in the previous embodiment, an axial bore 625 extends through the proximal end 626 of mounting portion 620 to receive the distal end portion 564d of control rod 564.

As in the previous embodiment, disposable loading unit 530 includes an axial drive assembly 660 which, among other things, transmits the longitudinal drive forces exerted by control rod 564 to the actuation sled 640 disposed within the spaced apart longitudinal slots 642 that extend through staple cartridge 534. A plurality of staple pushers 643 are operatively associated with slots 642 and are sequentially contacted by actuation sled 640 as it is driven through staple cartridge 534 by drive assembly 660. The staple pushers interact with the plurality of staples housed within staple cartridge 534 to sequentially eject the staples therefrom.

Drive assembly 660 includes a bifurcated drive beam 662 having a distal working head 664 and a proximal engagement section 665 that includes a pair of engagement fingers 666a and 666b (see FIG. 25) configured to mountingly engage a drive block 668. Drive block 668 has a proximal porthole 670 for receiving the distal end 564d of control rod 564 when the proximal mounting portion 626 of loading unit 530 is inserted into the distal end of elongated body portion 514, as illustrated, for example, in FIG. 27.

Referring to FIG. 20, the distal end portion 564d of control rod 564 is formed with a flange 667 having a pair of diametrically opposed notches 669a and 669b dimensioned to accommodate the two opposed engagement fingers 666a and 666b when the control rod is received in the proximal portal 670 of drive block 668, as best seen in FIGS. 26 and 29. Thereafter, as illustrated in FIGS. 28 and 30, when loading unit 530 is rotated through approximately a 20° axial turn to engage coupling stems 628a and 628b within J-shaped coupling slots 630a and 630b, engagement fingers 666a and 666b are moved out of alignment with engagement notches 669a and 669b, and flange 667 is secured from exiting disposable loading unit 530 until its removal from surgical stapler 500. As seen when comparing FIGS. 27 to FIG. 28, the interior cavity 671 of drive block 668 is dimensioned to accommodate the extension of the distal portion 564a of control rod 564 into portal 670 during the insertion of the loading unit 530 into the distal end of body portion 514.

Referring again to FIG. 24, the working head 664 of drive assembly 660 is defined in part by vertical support strut 672 which supports a knife blade 674, and defines an abutment surface 675 for engaging actuation sled 640. A retention flange 678 projects distally from support strut 672 to retain a cam roller 680 which is configured to translate along the exterior camming surface 682 of anvil 536 during a stapling procedure to effect closure of the anvil against the bias of anvil spring 676. A longitudinal slot 684 extends through anvil 536 to accommodate the translation of retention flange 678, and a similar slot 692 is formed in the base 612 of channel 610 to accommodate the translation of retention foot 688 which supports balancing flange 686. Flange 686 serves to balance the clamping forces exerted by cam roller 680 on

anvil **536**. As in the previous embodiment, an anvil cover (not shown) can be provided to protect tissue from contacting components traveling along the exterior surface **682** of anvil **536** during a stapling procedure.

Referring to FIGS. **24** and **25**, disposable loading unit **530** is provided with a lockout assembly **700** configured to operate in two distal stages. In brief, during the first stage of operation, the lockout assembly functions to limit the longitudinal movement of control rod **564** with respect to the axial drive assembly **660** (see FIG. **46**). In the second stage of operation, i.e., after the disposable loading unit has been removed from the apparatus following a stapling procedure, the lockout assembly serves to prevent subsequent utilization of the loading unit by blocking the entry of control rod **564** into the proximal portal **670** of drive block **668** (see FIG. **51**).

As best seen in FIG. **25**, preferred lockout assembly **700** includes a blocking plate **710** having a pair of parallel support arms **712a** and **712b** which depend distally therefrom. A central aperture **716** is formed in blocking plate **710** which is dimensioned and configured to accommodate the longitudinal translation of control rod **564**. Aperture **716** includes diametrically opposed slots **717a** and **717b** to accommodate the engagement fingers **666a** and **666b** of the proximal portion **665** of actuation beam **662**. A retention spring **718** is connected to blocking plate **710** through the engagement of a pair of spaced apart tabs **720a** and **720b** with a pair of corresponding ports **722a** and **722b**. Retention spring **718** includes a mounting flange **724** for securing the spring to a mounting area **725** on the interior surface of the mounting portion **620** of disposable loading unit **530** (see FIG. **26**). The proximal end portion of retention spring **718** is defined by a pair of spaced apart camming ramps **726a** and **726b** which are angled proximally to interact with the distal flange **667** of control rod **564** when disposable loading unit **530** is removed from the apparatus (see generally FIG. **47**).

Lockout assembly **700** further includes a support plate **730** having a pair of depending arms **732a** and **732b** which interact with the support arms **712a** and **712b** of blocking plate **710** to maintain the blocking plate in a non-blocking position against the bias of retention spring **718** (see FIG. **26**). Support plate **730** is formed with a central slotted region **733** which accommodates the lower portion of drive beam **662**. A detent **734** is formed within slotted region **733** for interacting with distal and proximal complementary recesses **735a** and **735b** formed in the lower portion of drive beam **662**.

In use, when drive beam **662** is driven distally, as shown for example in FIG. **44**, support plate **730** is drawn therewith through the engagement of detent **734** with proximal recess **735b**. As a result, blocking plate **710** is released and translates in a direction transverse to the longitudinal axis of control rod **564** under the bias of retention spring **718**. As shown for example in FIG. **45**, while control rod **564** is extending through aperture **716**, blocking plate **710** remains in a non-blocking position. However, when control rod **564** is fully retracted to open anvil **536** after a stapling procedure, blocking plate **710** moves into a limiting position, engaging the distal portion **564d** of control shaft **564**, as illustrated in FIG. **46**. In this position, blocking plate **710** effectively limits the range of longitudinal motion of control rod **564**, the range being defined by the reduced diameter portion at the distal end of control rod **564**.

Upon full withdrawal of flange **667** from drive block **668**, blocking plate **710** is free to translate into a full blocking position under the bias of retention spring **718** to block the

proximal portal **670** of drive block **668**, as illustrated in FIG. **49**. The function of lockout assembly **700** and its interaction with control rod **564** and axial drive assembly **660** will be discussed in further detail hereinbelow.

Referring now in sequential order to FIGS. **31–38**, to initiate operation of surgical stapler **500**, a desired disposable loading unit of a particular size and kind is selected from a group of different units and loaded into the distal end of body portion **514**. The loading unit, i.e., loading unit **530**, is mounted to stapler **500** by inserting the proximal mounting portion **626** into the distal end of body portion **514** and rotating the unit to securely engage the bayonet connection (see FIGS. **22** and **23**). A preferred degree of rotation is between about 5° and about 40° , while about 20° is most preferred. At such a time, support tube **588** is urged proximally from the position shown in FIG. **22** to that which is illustrated in FIG. **23**. As a result, rack lock **580** is moved into an interactive position shown in FIG. **31**, wherein the toothed rack **542** of actuation shaft **540** may be engaged upon the distal advancement thereof. As illustrated in FIG. **31**, when actuation shaft **540** is in its proximal-most position biased by constant force spring **554**, anvil **536** is in an open position to receive body tissue such as tubular vessel **750**. At such a time, pawl **544** is engaged in the distal-most tooth on toothed rack **542** and actuation handle **526** may be manipulated against the bias of spring **538** to advance the toothed rack.

As best seen in FIG. **32**, upon initial manipulation of actuation handle **526** through a first segment of the actuation stroke (i.e., the clamping stroke segment), actuation shaft **540** is driven in a distal direction by the interaction of pawl **544** and toothed rack **542**. Thereupon, the engagement hook **752** of rack lock **580** engages a keeper notch **754** formed adjacent the distal fastening portion **558** of actuation shaft **540**. At such a time, anvil **536** is moved to a closed position by the advancement of cam roller **680** along the proximal camming portion of anvil surface **682**, and the proximal end of engagement hook **752** is in abutment with a buttress **755** formed on the under surface of actuation shaft **540**. As a result, further distal translation of actuation shaft **540** is prohibited and anvil **536** is maintained in a clamped position.

If, at such a time, the user of the apparatus desires to unclamp tubular vessel **750** by opening anvil **536**, this can be accomplished through the manipulation of a retraction mechanism (described below) associated with handle assembly **512** which serves to disengage rack lock **580** and pawl **544** from actuation shaft **540** to permit the user to draw the actuation shaft in a proximal direction, as illustrated in FIG. **33**.

Referring back to FIG. **18**, the retraction mechanism preferably includes a pair of retractor knobs **760a** and **760b** which are connected to the proximal end of actuation shaft **540** by a coupling rod **762**. Coupling rod **762** includes right and left engagement portions **764a** and **764b** for receiving retractor knobs **760a** and **760b** and a central portion **764c** which is dimensioned and configured to translate within a pair of longitudinal slots **766a** and **766b** formed in actuation shaft **540** adjacent the proximal end thereof. A release plate **768** is operatively associated with actuation shaft **540** and is mounted for movement with respect thereto in response to manipulation of retractor knobs **760a** and **760b**. More particularly, a pair of spaced apart pins **767a** and **767b** extend outwardly from a lateral face of actuation shaft **540** to engage a pair of corresponding angled cam slots **769a** and **769b** formed in release plate **768**. The cam slots define the path through which the release plate moves with respect to the actuation shaft **540**, and more specifically, with respect to the toothed rack **542**. A transverse slot **770** is formed at

the proximal end of release plate 768 to accommodate the central portion 760c of coupling rod 762, and elongated slots 772 and 774 are defined in the barrel section 522 of handle assembly 520 to accommodate the longitudinal translation of coupling rod 762 as retraction knobs 760a and 760b move in conjunction with actuation shaft 540. Coupling rod 762 is biased distally by spring 765a which is secured at one end to coupling rod portion 764c and at the other end to post 765b on actuation shaft 540.

Referring again to FIG. 33, when it is desirable to open anvil 536 to release the clamped body tissue 750, the user of apparatus 500 pulls retraction knobs 760a and 760b proximally, whereupon release plate 768 translates in generally proximal direction along the path of angled cam slots 769a and 769b (see generally FIGS. 39 and 40). Consequently, the release plate urges the engagement hook 752 of rack lock 580 out of keeper notch 754 and forces pawl 544 out of engagement with toothed rack 542. At such a time, the user can draw actuation shaft 540 in a proximal direction, causing cam roller 680 to be drawn proximally with actuation beam 662. As a result, anvil 536 moves to an open position under the bias of anvil spring 676 and actuation handle 526 returns to a neutral position under the bias of torsion spring 538. Once actuation shaft 540 has been returned to its proximal-most position, stapling apparatus 500 is in a reset condition.

Referring now to FIG. 34, to clamp body tissue 750 once again, actuation handle 526 is manipulated through the clamping segment of an actuation stroke to drive actuation shaft 540 distally until the engagement hook 752 of rack lock 580 is once again engaged in keeper notch 754 and in abutment with buttress 755. If, at such a time, the user of apparatus 500 is confident that the stapling procedure can commence, rack lock 580 must be manually released from keeper notch 754 to permit subsequent distal movement of actuation shaft 540. This is accomplished by way of a manual release mechanism operatively associated with handle assembly 512 which interacts with the proximal release tail 757 of rack lock 580, as shown in FIG. 35. The details of a preferred construction of rack lock (or engagement member) 580 are illustrated in FIG. 43.

Referring back once again to FIG. 18, the manual release mechanism preferably includes a pivoting release member 780 mounted on a boss 784 and biased away from the release tail 757 of rack lock 580 by a coiled torsion spring 786. A pair of opposed winglets, i.e., winglet 788, project laterally from release member 780 to support release knobs 790a and 790b, respectively. Release member 780 has a downturned nose 792 which is dimensioned to contact the release tail 757 of rack lock 580 when release knobs 790a and 790b are manipulated by the user in the direction indicated by arrow "A" in FIG. 35.

Referring once again to FIG. 35, upon manipulation of release knobs 790a and 790b and the consequential liberation of rack lock 580, actuation shaft 540 is free to translate in a distal direction in response to manipulation of actuation handle 526. At such a time, the linear position of actuation shaft 540 is maintained through the engagement of pawl 544 and toothed rack 542.

Turning to FIG. 36, manipulation of actuation handle 526 toward stationary handle 524 through a stapling stroke segment causes pawl 544 to advance toothed rack 542, and hence actuation shaft 540 and control rod 564, in a distal direction. As a result, the axial drive assembly 660 supported within loading unit 530 is driven distally to cause actuation sled 640 to intersect with pushers 643 to sequentially eject

staples from cartridge 534. At the same time, knife blade 674 travels behind actuation sled 640, forming an incision in the stapled body tissue. As shown in FIG. 36, one complete stapling stroke effects firing of only a portion of the staples within cartridge 534. As previously described, multiple partial strokes can also be used to incrementally advance drive rod 564, i.e. pawl 544 can advance rack 542 one tooth at a time.

Referring to FIG. 37, all of the staples within cartridge 534 are ejected and applied to the tubular vessel 750. If a loading unit having a greater length had been employed with stapling apparatus 500, additional stapling strokes would have been required to advance actuation shaft 540 further. In total, the toothed rack 542 of actuation shaft 540 is preferably dimensioned to accommodate at least four complete stapling strokes of 15 mm each. Thus, if each complete stapling stroke of actuation handle 526 advances the actuation shaft 15 mm, stapling apparatus 500 can be used to fire disposable loading units that are configured to apply staple lines of 15 mm, 30 mm, 45 mm, and 60 mm using a whole number of complete strokes.

Referring now to FIG. 38, at the conclusion of the stapling procedure, to move anvil 536 to an open position and release stapled body tissue 750 from surgical apparatus 500, the user once again employs the retraction knobs 760a and 760b associated with the barrel portion 522 of handle assembly 520. More particularly, as best seen in FIGS. 39-42 proximal retraction of knobs 760a and 760b causes coupling rod 762 (FIG. 18) to translate proximally within the longitudinal slots 766a and 766b formed at the proximal end of actuation shaft 540. As a result, release plate 768 translates along an angled path defined by cam slots 769a and 769b, urging the engagement hook 752 of rack lock 580 and the pawl 544 (not shown) out of engagement with toothed rack 542. Thereupon, as illustrated in FIG. 38, actuation shaft 540 is free to translate in a proximal direction under the bias of the user and constant force spring 554. Consequently, the axial drive assembly 660 within disposable loading unit 530 is drawn proximally by the head of control rod 564, and anvil 536 moves to an open position as cam roller 680 is retracted.

Referring now to FIG. 45, as control rod 564 is withdrawn in a proximal direction from its distal-most position illustrated in FIG. 44, blocking plate 710 rides along control rod 564 and is maintained in an upright position against the bias of retention spring 718. However, as illustrated in FIG. 46, as reduced diameter distal end portion 564d of control rod 564 approaches its proximal-most position, blocking plate 710 is urged toward the control rod such that the peripheral edge of aperture 716 engages distal end portion 564d of control rod 564 (see also FIG. 50). Further proximal movement of control rod 564 draws drive block 668 to its proximal-most position illustrated in FIG. 47, wherein flange 667 interacts with camming ramps 762a and 762b of retention spring 718 and at least partially lifts blocking plate 710. At such a time, distal movement of control rod 564 is limited due to interaction between blocking plate 710 and the larger diameter ledge where the proximal end of 564d meets the larger diameter of rod 564. However, control rod 564 is still afforded a limited range of longitudinal motion along reduced diameter portion 564d of control rod 564 so that anvil 536 can be moved between open and closed positions. Accordingly, anvil 536 may be easily closed to facilitate removal of surgical apparatus 500 through a trocar or cannula device.

As best seen in FIG. 47, when axial drive assembly 660 and the drive block 668 associated therewith assume their proximal-most position, the detent 734 on support plate 730 engages distal recess 735a. As such a time, support plate 730

is securely retained in its final rest position to prevent the plate from floating within disposable loading unit 530 after it has been removed from surgical apparatus 500.

Referring to FIG. 48, to remove disposable loading unit 530 from the distal end of body portion 514, the loading unit is shifted proximally and rotate to disengage the bayonet coupling. Simultaneously, the engagement fingers 666a and 666b are re-aligned with the notches 669a and 669b in flange 667. The flange can now further bias locking plate 710 upward, allowing for the movement of disposable loading unit 530 from the distal end of body portion 514. As soon as flange 667 moves past camming ramps 762a and 762b and blocking plate 710, the blocking plate is free to translate into a full blocking position under the bias of retention spring 718. In this position, which is best seen in FIG. 51, entry of the distal end of control rod 564 into the proximal portal 670 of drive block 668 is advantageously prohibited. Accordingly, a fired or partially fired disposable loading unit cannot be subsequently utilized after it has been removed from surgical apparatus 500.

Although the subject invention has been described with respect to preferred embodiments, it will be readily apparent to those having ordinary skill in the art to which it appertains that changes and modifications may be made thereto without departing from the spirit or scope of the subject invention as defined by the appended claims.

What is claimed is:

1. A surgical stapler comprising:

- a) a handle assembly including a stationary handle and a pivotable handle mounted for manipulation through an actuating stroke;
- b) an elongated body extending distally from the handle assembly and defining a longitudinal axis;
- c) an actuation member supported within the handle assembly and mounted for linear movement in response to movement of the pivotable handle through the actuation storage;
- d) a staple cartridge supported by the elongated body and containing a plurality of staples;
- e) an anvil mounted adjacent the cartridge, the anvil having a fastener forming surface thereon and being mounted for relative movement with respect to the cartridge between an open position spaced from the staple cartridge and a closed position in closed cooperative alignment with the staple cartridge; and
- f) an actuator operatively connected to the actuation member, the actuator being configured to move relative to the staple cartridge and anvil to initially effectuate relative movement of the anvil and cartridge from an open position to a closed position and to subsequently effectuate sequential ejection of the staples from the cartridge in response to movement of the pivotable handle through the actuation stroke.

2. A surgical stapler as recited in claim 1, wherein the actuation member includes a toothed rack and the pivotable handle includes a spring biased pawl member configured to selectively engage the toothed rack to advance the actuation member in response to manipulation of the pivotable handle.

3. A surgical stapler as recited in claim 2, further comprising an engagement hook disposed within the handle assembly and biased toward the toothed rack for initially engaging a keeper notch formed adjacent a distal end of the toothed rack to limit the extent of the linear movement of the toothed rack.

4. A surgical stapler as recited in claim 3, further comprising release means for manually disengaging the engagement hook from the keeper notch.

5. A surgical stapler as recited in claim 4, wherein the release means includes at least one release knob operatively associated with the handle assembly, and a pivoting release member operatively connected to the release knob which has a release finger projecting therefrom to interact with a flange projecting from the engagement knob.

6. A surgical stapler as recited in claim 4, wherein the toothed rack has a particular rack length and the staple cartridge houses a staple line having a particular linear dimension which is less than or equal to the rack length of the toothed rack.

7. A surgical stapler as recited in claim 6, further comprising retracting means for effectuating manual retraction of the toothed rack in a proximal direction at any point in the actuating stroke to facilitate retraction of the actuator and movement of the anvil from the closed position to the open position.

8. A surgical stapler as recited in claim 7, wherein the retracting means comprises at least one retracting knob operatively associated with the handle assembly, and a release plated mounted adjacent the toothed rack and movable with respect thereto in response to initial proximal movement of the retracting knob for moving the engagement hook and the pawl out of engagement with the toothed rack.

9. A surgical stapler as recited in claim 8, wherein the release plate includes a pair of spaced apart, angled cam slots, and a pair of cam pins project laterally from the toothed rack to interact with the angled cam slots so as to facilitate relative movement of the release plate and the toothed rack.

10. A surgical stapler as recited in claim 9, further comprising a constant force spring disposed adjacent a proximal end of the handle assembly and operatively connected to the toothed rack for biasing the toothed rack in a proximal direction.

11. A surgical stapler as recited in claim 2, wherein the actuator includes an elongated actuation beam having a coupling at a proximal end thereof for receiving the distal end portion of an elongated control rod, and a support flange at a distal end portion thereof supporting a knife block configured to form an incision in stapled body tissue.

12. A surgical stapler as recited in claim 11, wherein the actuator further includes a cam roller mounted adjacent the support flange and configured to translate relative to an exterior camming surface of the anvil to effectuate movement of the anvil from the open position to the closed position.

13. A surgical stapler as recited in claim 11, wherein an actuation sled is supported within the staple cartridge and is mounted to translate ahead of the support flange to sequentially interact with a plurality of staple pushers housed within the staple cartridge adjacent the staples.

14. A surgical stapler as recited in claim 13, wherein the actuation sled is only mounted for translation in a distal direction in response to movement of the actuation beam.

15. A surgical stapler as recited in claim 11, wherein the staple cartridge and the anvil form part of a disposable loading unit, the disposable loading unit further including a carrier having a distal housing portion configured to support the staple cartridge and anvil, and a proximal mounting portion dimensioned for reception in the distal end portion of the elongated body.

16. A surgical stapler as recited in claim 15, further comprising a lockout assembly mounted within the carrier adjacent a proximal end thereof and configured to interact with the distal end portion of the control rod to limit the range of longitudinal translation of the control rod within the coupling at the proximal end of the actuation beam once the toothed actuation rack has been withdrawn to a proximal-most position.

25

17. A surgical stapler as recited in claim 16, wherein the lockout assembly includes a spring biased blocking plate mounted for movement in a direction transverse to the longitudinal axis of the elongated body between an initial non-blocking position and a subsequent blocking position.

18. A surgical stapler as recited in claim 17, wherein a support plate is mounted for linear translation with the carrier from a first position, wherein the blocking plate is main-

26

tained in the non-blocking position against the bias of a spring to a second position spaced distal of the blocking plate.

19. A surgical stapler as recited in claim 18, wherein the actuation beam includes means for engaging the support plate to move the support plate from the first position to the second position.

* * * * *

专利名称(译)	外科缝合器		
公开(公告)号	USR40514	公开(公告)日	2008-09-23
申请号	US11/311887	申请日	2005-12-19
申请(专利权)人(译)	美国外科CORPORATION		
当前申请(专利权)人(译)	泰科医疗集团LP		
[标]发明人	MASTRI DOMINICK L VIOLA FRANK J ALESI JR THOMAS W GEISTE ROBERT J WILSON JON		
发明人	MASTRI, DOMINICK L. VIOLA, FRANK J. ALESI, JR., THOMAS W. GEISTE, ROBERT J. WILSON, JON		
IPC分类号	A61B17/068 A61B17/072		
CPC分类号	A61B17/0684 A61B17/072 A61B17/07207 A61B2017/0046 A61B2017/00477 A61B2017/07214 A61B2017/07271 A61B2017/07278 A61B2017/292 A61B2017/2923 A61B2017/2931 A61B2017/2939 A61B2017/320052		
审查员(译)	SMITH , SCOTT A.		
外部链接	Espacenet USPTO		

摘要(译)

本文描述了一种手术装置，其可用于发射不同类型和尺寸的一次性装载单元。在优选实施例中，该装置将平行排的外科紧固件施加到身体组织上，并在内窥镜或腹腔镜外科手术过程中伴随地在各排钉之间形成切口。该装置可以与一次性装载单元一起使用，该一次性装载单元构造成应用线性行的钉，其长度从大约15mm到大约60mm，并且可以用于发射包含手术夹和单个钉的一次性装载单元。

