



US 20170086880A1

(19) **United States**

(12) **Patent Application Publication**  
**TANG et al.**

(10) **Pub. No.: US 2017/0086880 A1**  
(43) **Pub. Date: Mar. 30, 2017**

(54) **TRANS-ENDOSCOPIC AND LAPAROSCOPIC SURGERY PORT**

**Publication Classification**

(71) Applicant: **Tanam Medical Inc.**, Victoria (CA)

(51) **Int. Cl.**  
*A61B 17/34* (2006.01)  
*A61B 90/40* (2006.01)  
*A61M 39/02* (2006.01)  
*A61B 17/02* (2006.01)

(72) Inventors: **Bao TANG**, Victoria (CA); **Brad J. AMSON**, Victoria (CA)

(52) **U.S. Cl.**  
CPC ..... *A61B 17/3423* (2013.01); *A61B 17/0218* (2013.01); *A61B 90/40* (2016.02); *A61M 39/0247* (2013.01); *A61B 2017/3445* (2013.01); *A61B 2017/3466* (2013.01); *A61B 2017/349* (2013.01); *A61M 2039/0261* (2013.01); *A61M 2039/027* (2013.01); *A61M 2039/0279* (2013.01); *A61M 2039/0297* (2013.01)

(73) Assignee: **Tanam Medical Inc.**, Victoria (CA)

(21) Appl. No.: **15/285,010**

(22) Filed: **Oct. 4, 2016**

**Related U.S. Application Data**

(62) Division of application No. 14/404,508, filed on Nov. 28, 2014, now Pat. No. 9,486,198, filed as application No. PCT/CA2013/000156 on Feb. 20, 2013.

(60) Provisional application No. 61/601,863, filed on Feb. 22, 2012.

**Foreign Application Priority Data**

Jun. 6, 2012 (CA) ..... 2778976

**ABSTRACT**

(57) Surgical access ports useful in minimally invasive surgical procedures are provided. The access ports comprise a cannula that defines a passageway for one or more surgical instruments through a tissue tract and a dome extending from the cannula to provide an expanded diameter for receiving one or more surgical instruments.

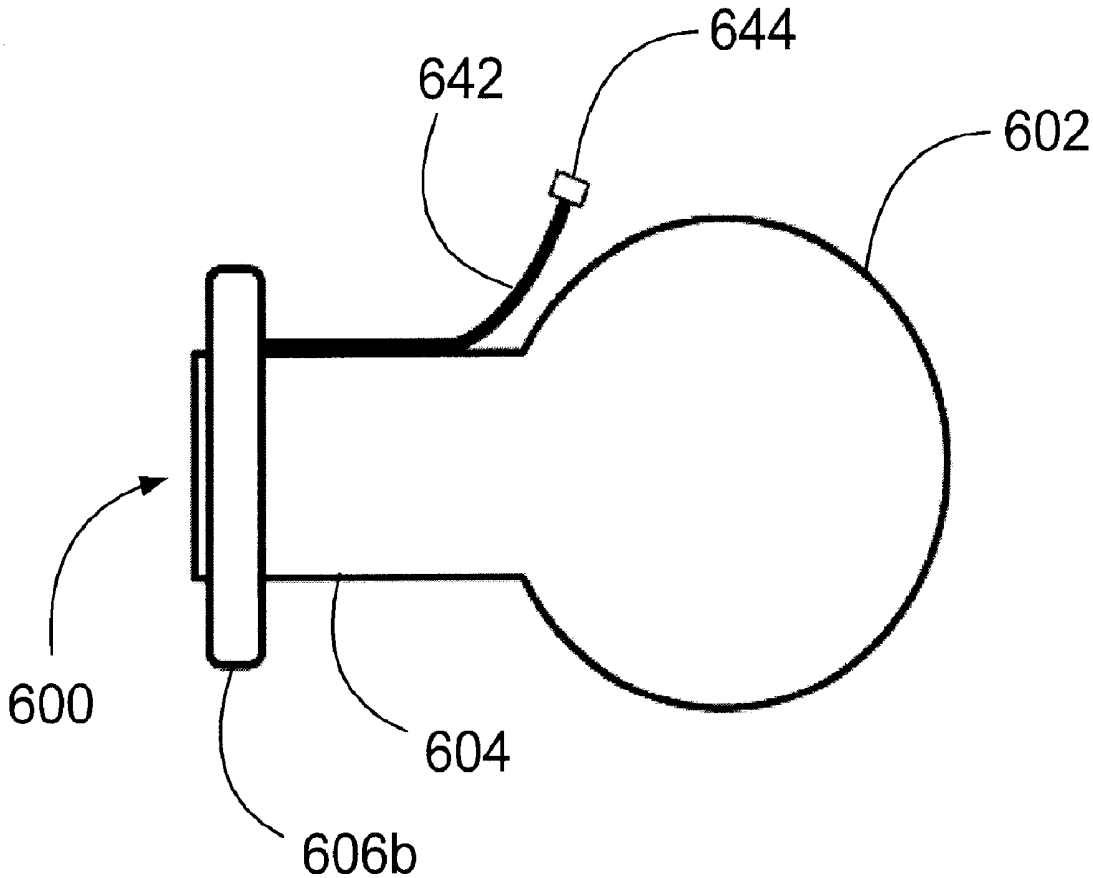

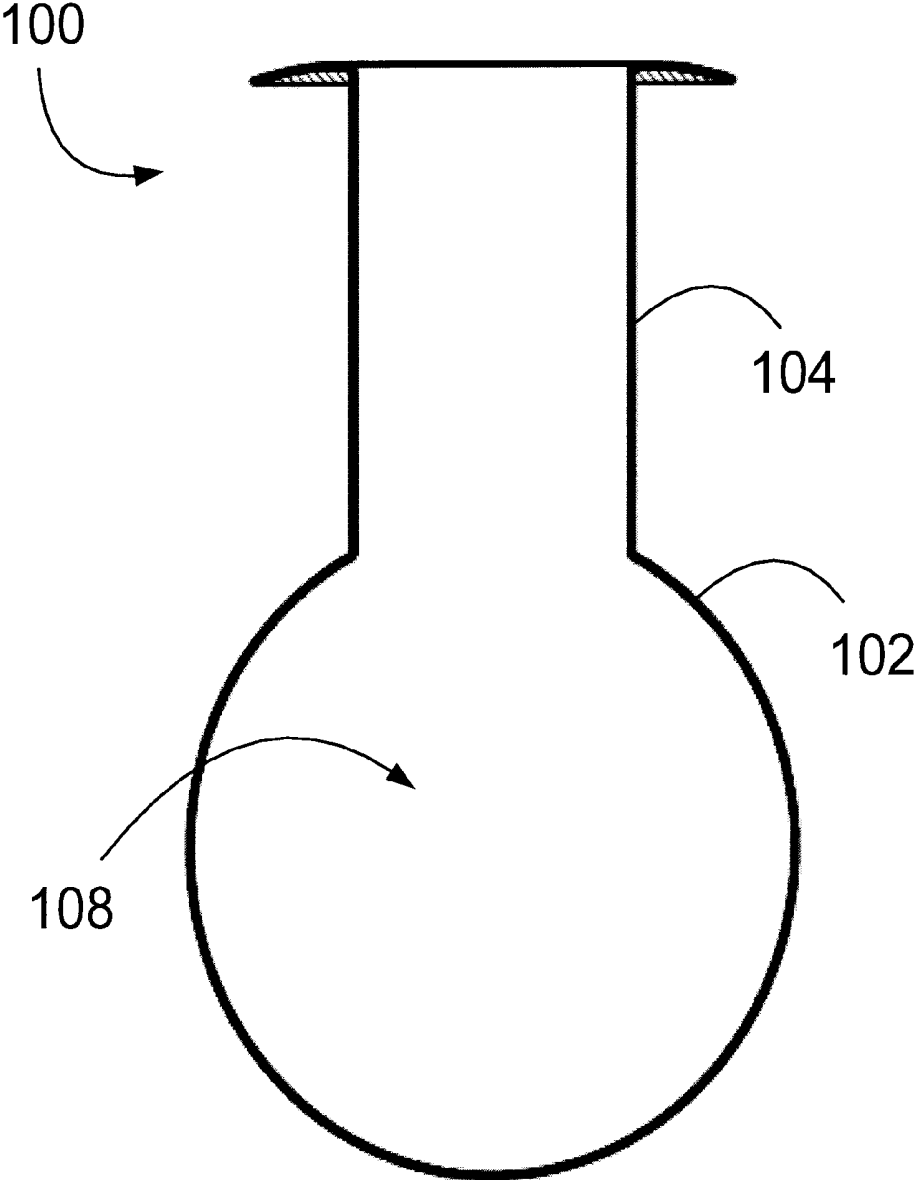

Fig. 1

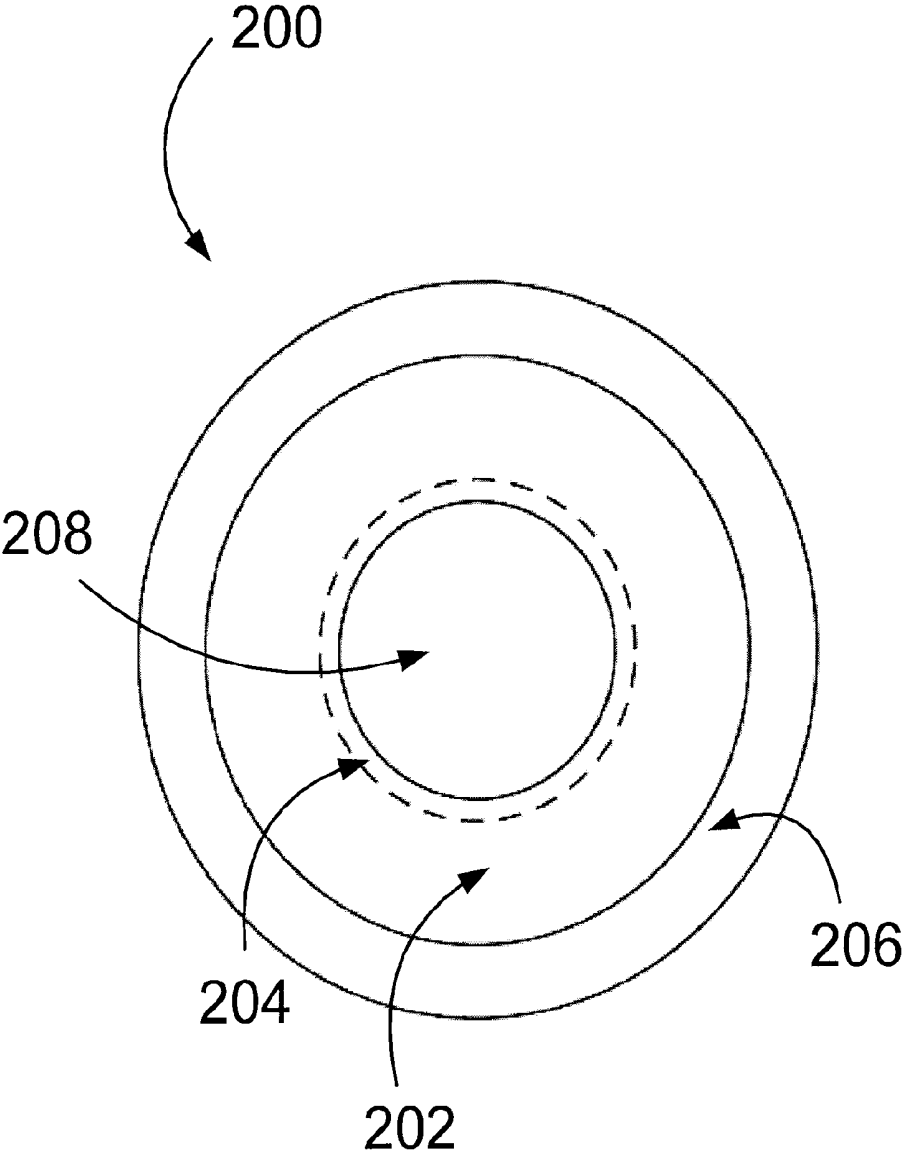

Fig. 2

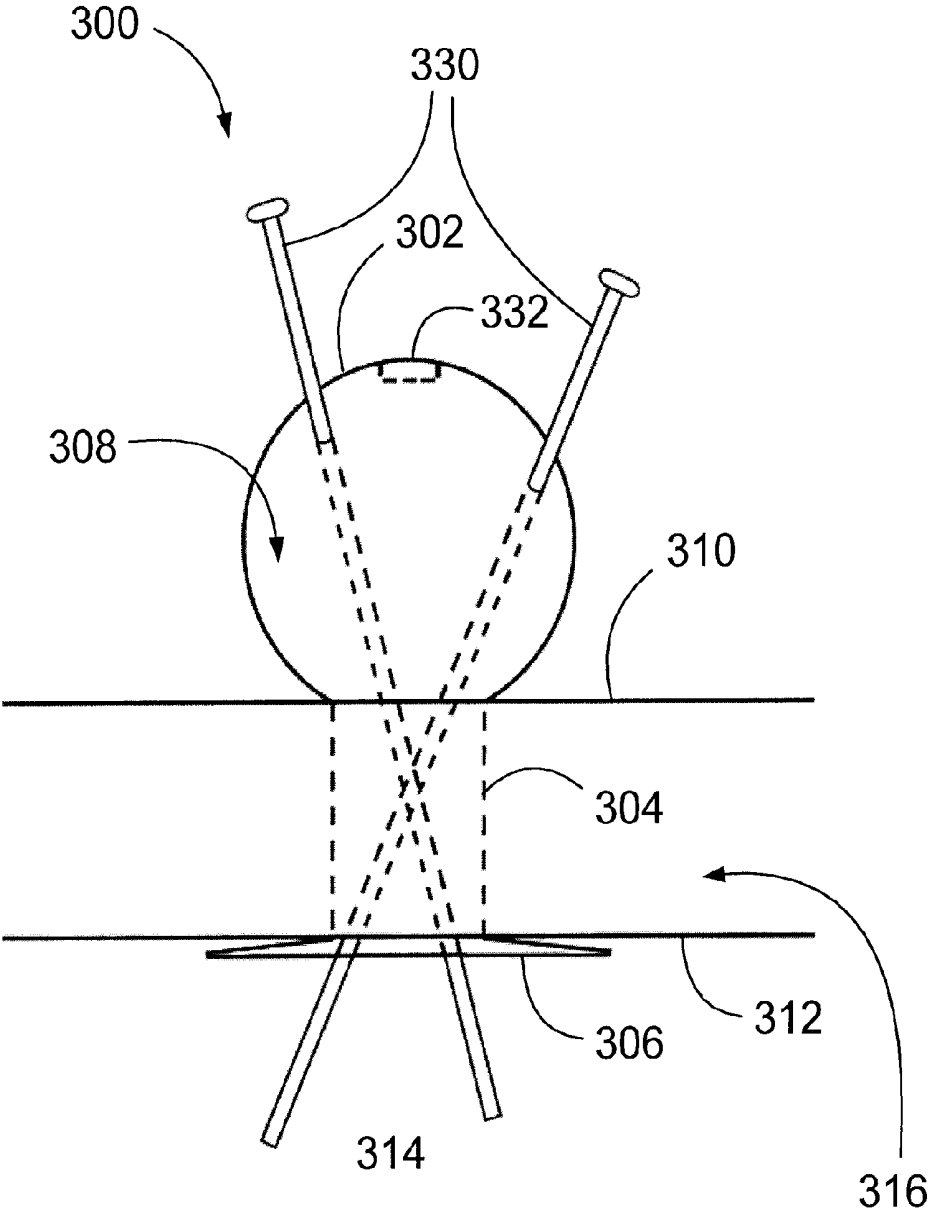

Fig. 3

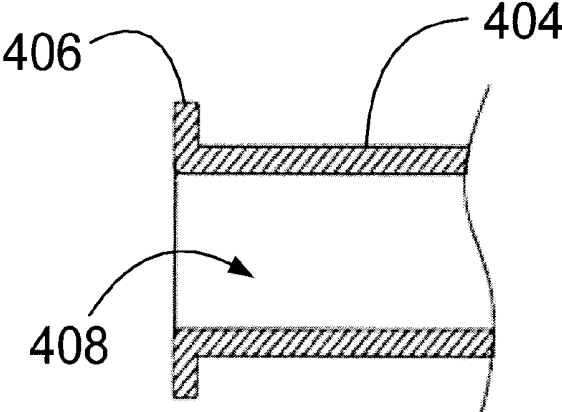

FIG. 4A

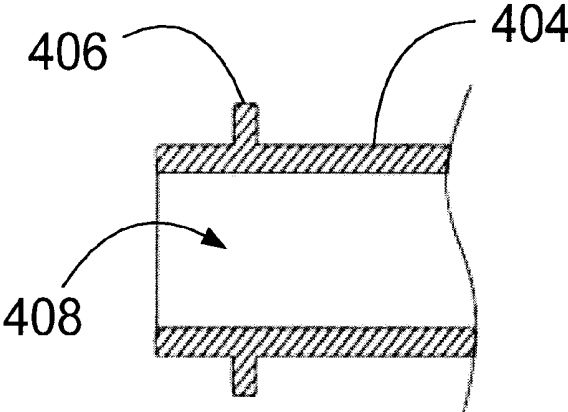

FIG. 4B

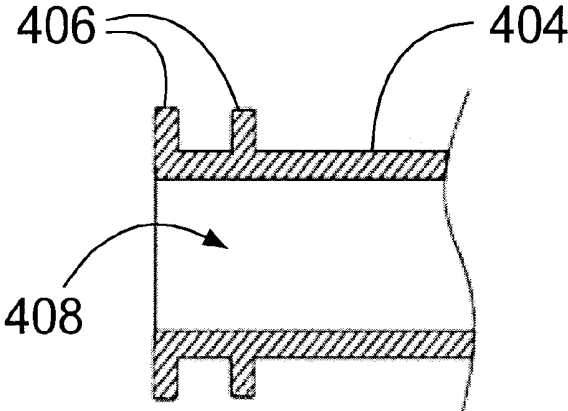

FIG. 4C

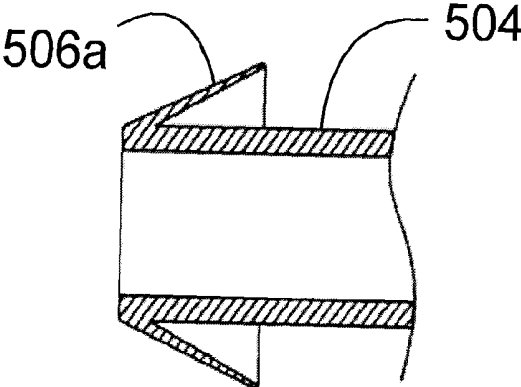

FIG. 5A

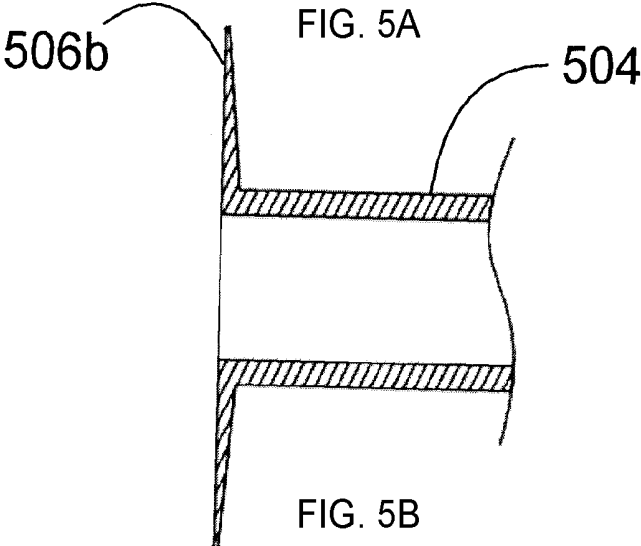

FIG. 5B

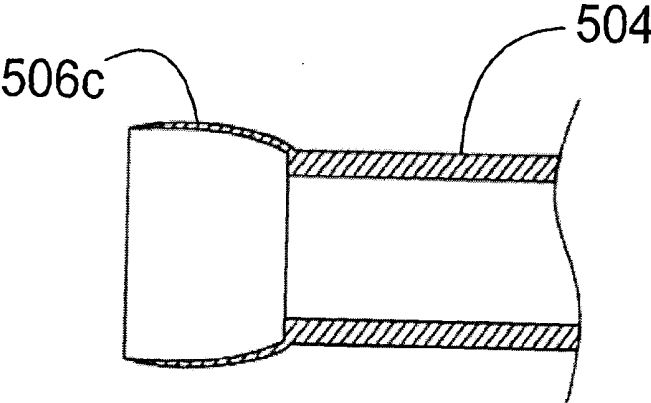
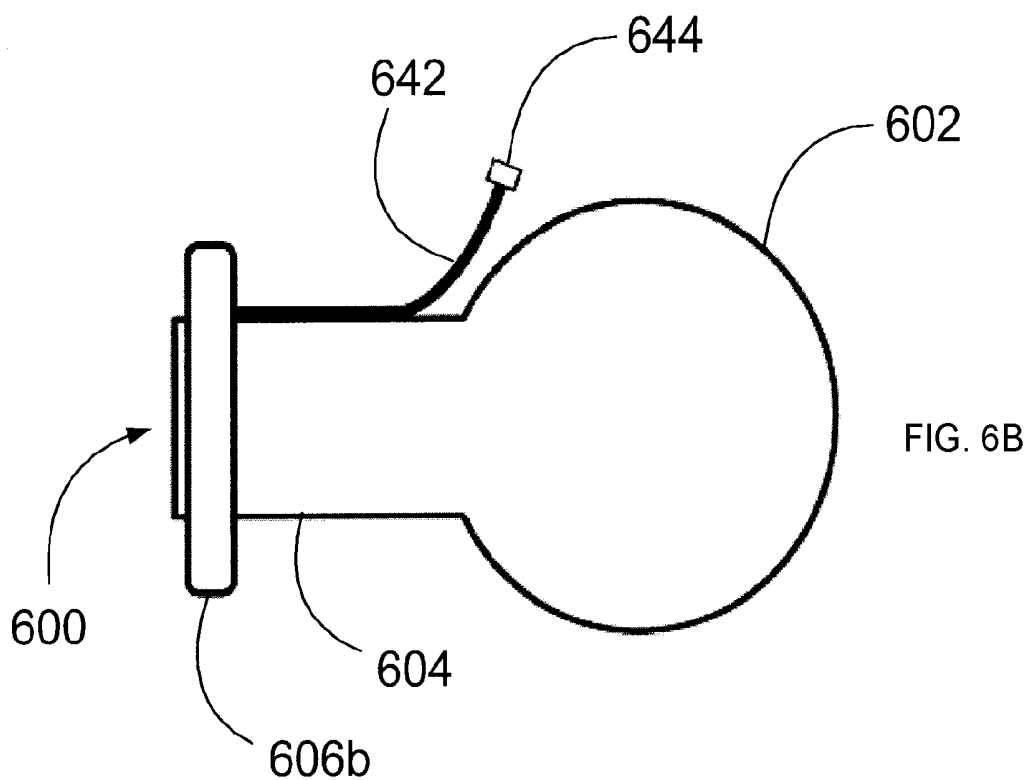
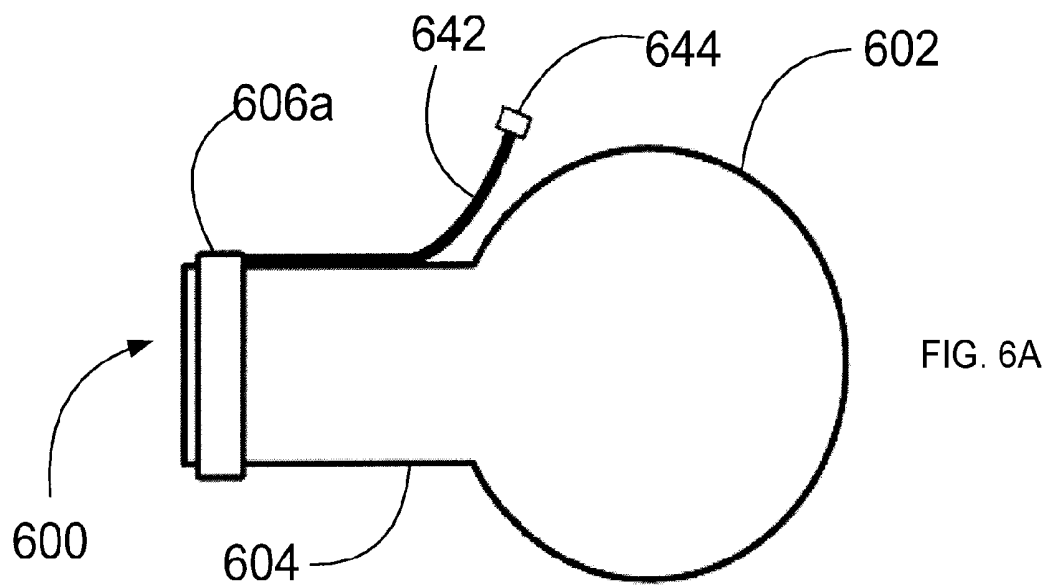

FIG. 5C



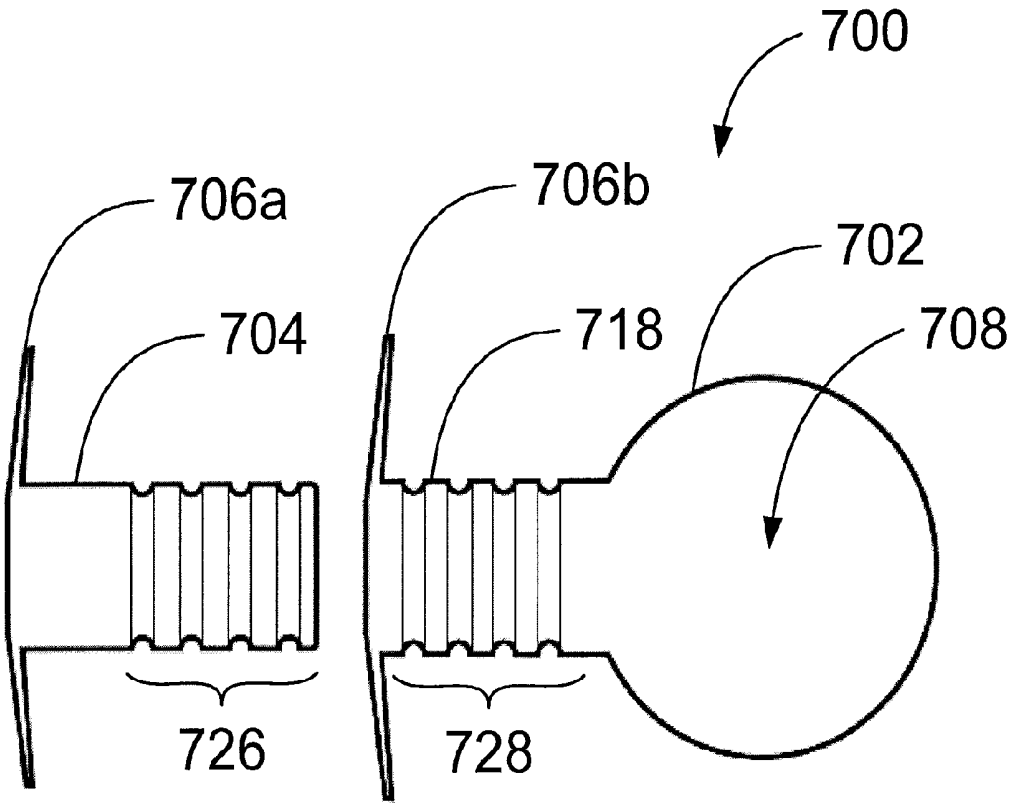

Fig. 7

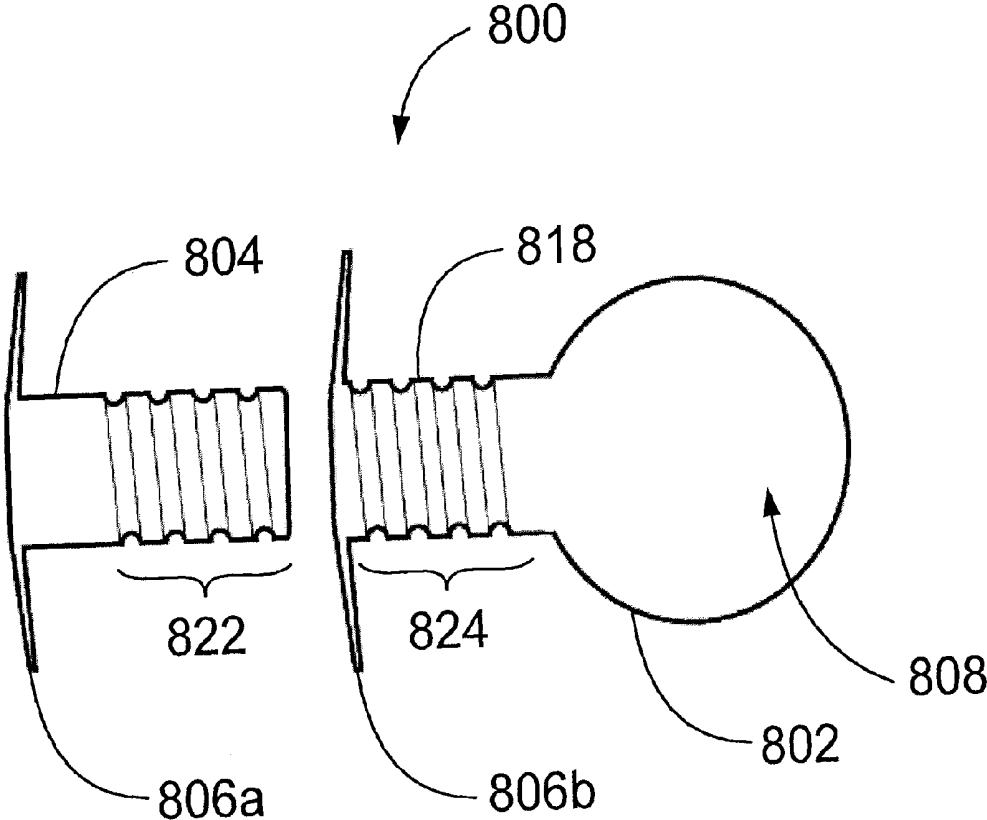

Fig. 8

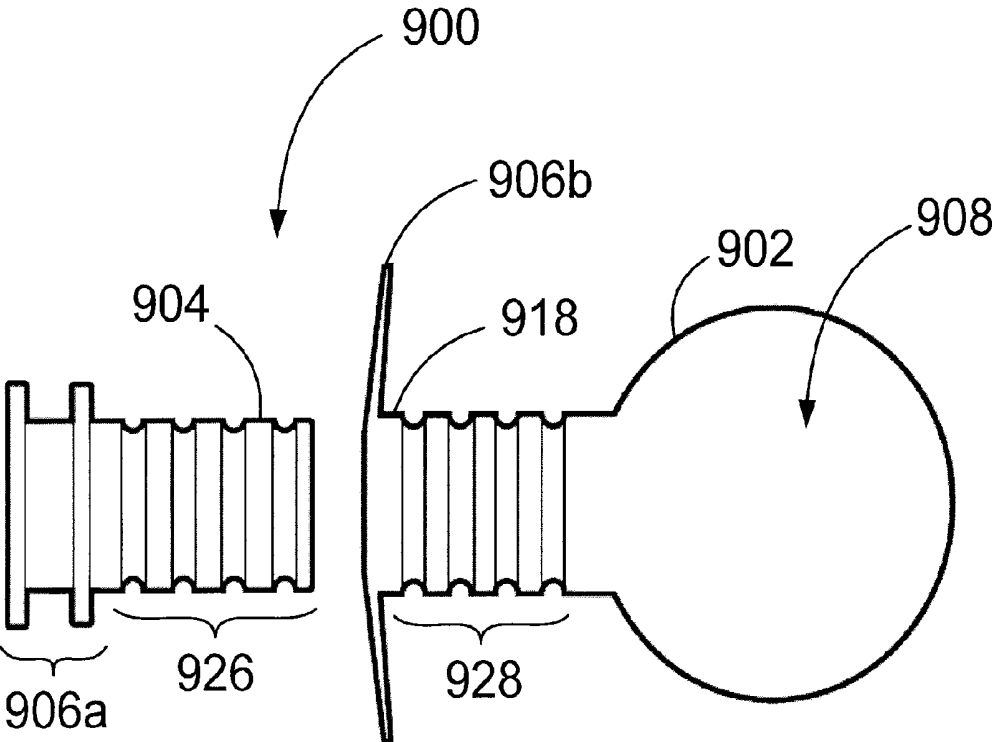

Fig. 9

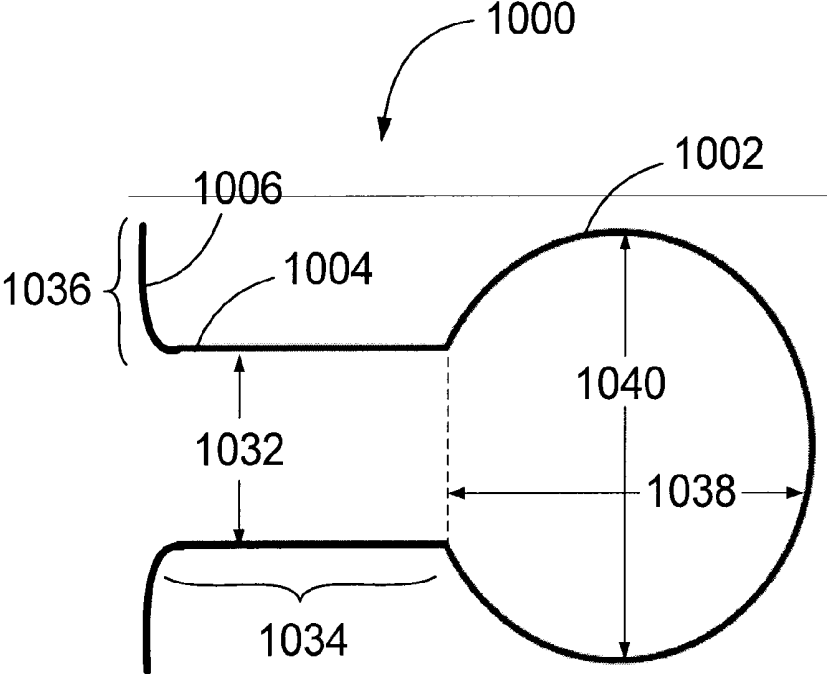

FIG. 10A

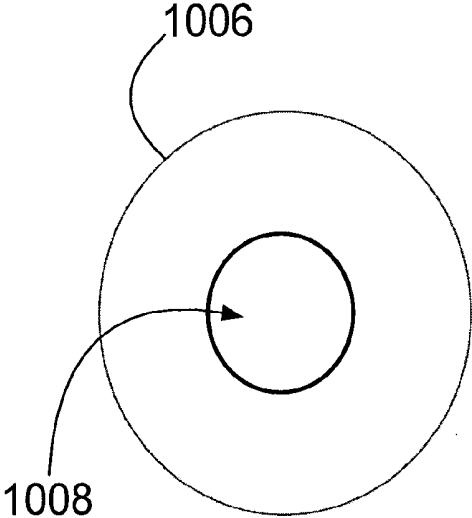

FIG. 10B

## TRANS-ENDOSCOPIC AND LAPAROSCOPIC SURGERY PORT

### FIELD OF THE INVENTION

**[0001]** The present invention pertains to the field of surgical devices and more specifically, to an access port useful in minimally invasive surgical procedures such as laparoscopic and/or (trans-) endoscopic procedures.

### BACKGROUND OF THE INVENTION

**[0002]** Minimally invasive surgery, such as endoscopic and/or laparoscopic procedures, is a type of surgery performed through one or more small incisions in a patient's body, usually less than an inch in dimension. Some advantages of minimally invasive surgery are that patients experience reduced physical and physiological trauma, much smaller scarring, and faster post-surgery recovery times.

**[0003]** The single port approach to minimally invasive surgery, whether that be through a single incision or via a natural orifice such as the oral cavity, nasal passages, the navel, the vagina, and the anus, for example, provides the benefit of smaller and fewer body cavity incisions. Single-port procedures, however, require several instruments to be inserted and manipulated through a single entry into a tissue tract, thereby, limiting the freedom of movement for manipulating the multiple instruments inserted through a single port.

**[0004]** Access ports are commonly used in such minimally invasive surgical procedures to facilitate the introduction and manipulation of multiple instruments and equipment into a tissue tract through an incision or a natural orifice. The access ports are used to protect adjacent tissues from potential abrasion and/or tearing and/or incised damage caused by insertion and manipulation of the surgical instruments and equipment. Some procedures involve the use of insufflation gases to enlarge the area surrounding the target surgical site to create a larger, more accessible work area. Accordingly, access ports may be introduced into regions that require maintenance of the pressurized gas.

**[0005]** Current surgical access ports allow for single instrument access through each port, or allow for multiple instrument access through a rigid or semi-rigid cannula. These devices do not provide flexibility to the surgeon in selecting instrument size, and they restrict instrument movement with their rigid cannulas.

**[0006]** Access ports that allow for a wider range of motion of the multiple instruments inserted in a single entry port have been described. For example, United States Patent Publication No. 2010/0113886 describes a surgical port comprising tubular cannulas through which surgical instruments are inserted. The tubular cannulas are flexible in a region of attachment to the carrier enabling pivoting and swivelling of the surgical instruments. United States Patent Publication No. 2012/0022333 also describes an access port for the simultaneous use of multiple instruments. The apparatus comprises at least two ports for receiving a surgical instrument. Each port is connected to the apparatus via a ball joint to allow for a wide range of movement of the instrument. The size and number of surgical instruments that can be inserted in these access ports is, however, limited by the number of cannulas provided in the port.

**[0007]** United States Patent Publication No. 2010/0094227 describes a surgical access system comprising

multiple parts including a removable gel cap having a gel pad through which instruments may be inserted into a body cavity either directly or through one or more trocars. The gel pad provides a flat surface, i.e., an artificial body wall, having a limited diameter to permit flexible instrument placement and range of motion.

**[0008]** There continues to be a need for access ports for use in minimally invasive procedures that provide flexibility to the surgeon in selecting instrument size and maximize the range of motion of the instruments extending through the access port.

**[0009]** This background information is provided for the purpose of making known information believed by the applicant to be of possible relevance to the present invention. No admission is necessarily intended, nor should be construed, that any of the preceding information constitutes prior art against the present invention.

### SUMMARY OF THE INVENTION

**[0010]** An object of the present invention is to provide a surgical access port. In accordance with an aspect of the present invention, there is provided a surgical access port comprising: a cannula comprising a first end and a second end, wherein the first end is for insertion into a target site and defines a passageway for introduction of one or more surgical instruments; at least one retainer outwardly extending circumferentially about the first end of the cannula, wherein the retainer engages an inside surface of the target site when the first end of the cannula is inserted; and a dome extending from the second end of the cannula, wherein the dome comprises an expanded diameter for receiving one or more surgical instruments.

**[0011]** In accordance with another aspect of the invention, there is provided a surgical access port comprising a cannula having a first end and a second end, wherein the first end is for insertion into a target site to maintain a passageway for introduction of one or more surgical instruments; at least one retainer outwardly extending circumferentially about the first end of the cannula, wherein the retainer engages an inside surface of the target site when the first end of the cannula is inserted; an elongate receptacle having a mating end for matingly engaging the second end of the cannula; a dome extending from the receptacle at an end opposite from the mating end, wherein the dome comprises an expanded diameter for receiving one or more surgical instruments.

**[0012]** In accordance with another aspect of the invention, there is provided a method for performing a minimally invasive surgical procedure, the method comprising: positioning the access port, of the present invention, in a target site of a patient; and inserting one or more surgical instruments through the dome of the access port and into the target site.

### BRIEF DESCRIPTION OF THE FIGURES

**[0013]** FIG. 1 is a perspective view of an access port according to embodiments of the present invention showing the access port inserted at a target site;

**[0014]** FIG. 2 is a cross-sectional end view of an access port according to embodiments of the present invention;

**[0015]** FIG. 3 is a perspective view of an access port according to embodiments of the present invention showing the access port inserted through a tissue tract at an insertion site with instruments inserted;

**[0016]** FIGS. 4A-4C are partial cross-sectional side views of an access port according to embodiments of the present invention;

**[0017]** FIGS. 5A-5C are partial cross-sectional side views of an access port according to embodiments of the present invention in which exemplary states of a retainer are shown;

**[0018]** FIGS. 6A and 6B are cross-sectional side views of an access port according to embodiments of the present invention showing a deflated and inflated state of a retainer, respectively;

**[0019]** FIG. 7 is a cross-sectional side view of a two-piece access port according to embodiments of the present invention;

**[0020]** FIG. 8 is a cross-sectional side view of a two-piece access port according to embodiments of the present invention;

**[0021]** FIG. 9 is a cross-sectional side view of a two-piece access port according to embodiments of the present invention;

**[0022]** FIG. 10A is a cross-sectional side view of an example access port according to embodiments of the present invention; and

**[0023]** FIG. 10B is an end view of an example access port according to embodiments of the present invention.

## DETAILED DESCRIPTION OF THE INVENTION

### Definitions

**[0024]** The terms “subject” and “patient” as used herein refer to an animal in need of treatment.

**[0025]** The term “animal” as used herein, includes, but is not limited to, mammals including humans.

**[0026]** The terms “surgical instrument(s)” and “instrument(s)”, as used herein, refer to any medical instrument used in minimally invasive surgical procedures and can include, but is not limited to, standard hand instruments and articulating instruments.

**[0027]** The terms “minimally invasive surgery” and “minimally invasive surgical procedure(s)”, as used herein, refer to surgery performed through one or more small incisions in a patient’s body or through a natural orifice such as the oral cavity, nasal passages, the navel, the vagina, and the anus, and includes endoscopic and/or laparoscopic procedures.

**[0028]** The terms “target site” and “target cavity”, as used herein, refers to the location in the patient’s body where the minimally invasive surgical procedure is to occur and can include, but is not limited to, the abdominal cavity and the rectum.

**[0029]** The term “tissue tract”, as used herein, refers to the region of tissue through which instruments must pass through to reach the target site or target cavity to conduct the minimally invasive surgical procedure.

**[0030]** As used herein, the term “about” refers to a +/-10% variation from the nominal value. It is to be understood that such a variation is always included in any given value provided herein, whether or not it is specifically referred to.

**[0031]** Unless defined otherwise, all technical and scientific terms used herein have the same meaning as commonly understood by one of ordinary skill in the art to which this invention belongs.

**[0032]** The access ports according to the present invention comprise an elongate cannula having a first end and a second end, a retainer coupled to the first end of the elongate cannula to fix the first end of the cannula within a tissue tract, and an enclosed dome extending from the second end of the elongate cannula for receiving surgical instruments. Access ports of the present invention comprise a minimal number of cooperating parts to provide simplicity in design, cost effectiveness in manufacture, and facility in cleaning of the access port for reuse. According to some embodiments of the present invention, the access port is a single integrated unit. In other embodiments, the access port is comprised of two separable cooperating parts.

**[0033]** An access port according to embodiments of the present invention are for use, for example, in single port minimally invasive surgical procedures such as in single incision and/or limited port laparoscopic surgical procedures, including for example, abdominal, trans-navel, trans-vaginal, and trans-anal procedures. Access ports according to embodiments of the present invention can simultaneously accommodate multiple instruments in a range of sizes. As well, access ports according to embodiments of the present invention, further permit translational and angular degrees of freedom for instruments, thereby, providing a range of motion of the instruments extending through the access port.

**[0034]** Due to this flexibility provided to the operating surgeon, the access ports of the present invention are suitable for use in trans-endoscopic procedures or trans-anal minimally invasive surgery (TAMIS), for example, to treat such pathologies as polyps and small (T1) tumours typically located within the mid to upper area of the rectum. Procedures, such as TAMIS, generally involve the insertion of multiple surgical instruments into the anal canal as well as insufflation gases that create a more accessible work area. According to embodiments of the present invention, the access port comprises a self-sealing material such that the access port is in substantial sealed engagement with an inserted surgical instrument so as to maintain the gas pressure during the surgical procedure.

**[0035]** Referring now to the drawings, in which like reference numerals identify identical or substantially similar parts throughout the several views, FIG. 1 illustrates a cross-sectional side view of an access port **100** inserted at a target site according to embodiments of the present invention. Access port **100** includes an elongate cannula **104** having a first end and a second end, a retainer (not shown) coupled to the first end of the elongate cannula **104** to fix the first end of the cannula **104** at the target site when inserted, and an enclosed dome **102** extending from the second end of the elongate cannula **104** for receiving surgical instruments. As illustrated in FIG. 2, the cannula **204** defines a lumen **208**, the diameter of which is expanded by the dome **202** at the second end of the cannula **204**.

### Cannula

**[0036]** Referring to FIG. 3, the cannula **304** comprises an elongate, tubular body, dimensioned to accommodate one or more instruments **330** inserted therethrough. When inserted, the cannula **304** maintains a passageway through the tissue tract to facilitate the introduction and manipulation of the inserted instruments **330** in the target cavity **314**. The cannula **304** protects the adjacent tissues from abrasion, tearing, and/or incised damage caused by insertion and manipulation of multiple surgical instruments **330**. The

cannula **304** comprises a resilient, semi-rigid, elastomeric, material, that is biologically compatible. Depending on the particular embodiment, the cannula **304** can be composed of one or more materials that permit compression to facilitate installation of the cannula **304** into an insertion site, for example, at least one of rubber, synthetic rubber, silicone, non-latex silicone, ethylene propylene diene monomer (EPDM), ethylene-propylene copolymer (EP rubber), polyisoprene, polybutadiene, polyurethane, styrene-butadiene, ethylene vinyl acetate (EVA), polychloroprene (Neoprene), perfluoroelastomer (Kalrez®), and the like. Some embodiments comprise a composite, for example, a multilayer structure and/or a plurality of sheets of one or more polymer materials. For example, some embodiments comprise outer surfaces and/or sheets providing desirable functionality, for example, mechanical strength, abrasion resistance, antimicrobial properties, and the like.

**[0037]** The dimensions of the cannula **304** will vary according to the particular use. Embodiments of the present invention can be sized for insertion into different types of target sites, for example, single incision into abdominal cavities, trans-navel, trans-vaginal, and trans-anal orifices. In addition, embodiments can be sized for insertion into juvenile subjects or into adult subjects. As well, embodiments of the present invention can be sized for use in human subjects or animal subjects in veterinary applications. In some embodiments, for example in trans-anal procedures, the cannula **304** can be relatively short because the cannula **304** need only access the rectum which for a human adult is typically 12 cm in length. Accordingly, in some embodiments the cannula **304** comprises a length of about 1.5 cm, 2.0 cm, 2.5 cm, 3.0 cm, 3.5 cm, 4.0 cm, 4.5 cm, 5.0 cm, 5.5 cm, 6.0 cm, 6.5 cm, 7.0 cm, 7.5 cm, 8.0 cm, 8.5 cm, or any length therebetween. Similarly, the diameter of the cannula **304** can vary depending on the particular use. In some embodiments, the cannula **304** can have an outer diameter of about 1.5 cm, 2.0 cm, 2.5 cm, 3.0 cm, 3.5 cm, 4.0 cm, 4.5 cm, 5.0 cm, 5.5 cm, 6.0 cm, or any diameter therebetween.

#### Dome

**[0038]** The dome **302** of the access port **300** extends from the second end of the elongate cannula **304** to enclose the lumen **308**. The dome **302** refers to a region of expanded diameter at one end of the cannula **304**, for receiving surgical instruments **330**, and may comprise a variety of shapes. For example, the dome **302** may be in the shape of a bulb, a round globe, a symmetrical ellipse, an asymmetrical ellipse, an elongate balloon with a spherical end, an elongate balloon with a tapered end, among other shapes. The shape of the dome **302** is not essential to the practice of the invention, rather, it is the expansion of the diameter, and corresponding surface area, of the access port **300** at the region of the dome **302** portion that permits the accommodation of multiple instruments **330** in the access port **300** with a wide range of movement. Accordingly, the dimensions of the dome **302** can be selected based on the number and size of instruments to be used in a procedure, and the desired range of movement required.

**[0039]** The dimensions of the access port **300** in accordance with the present invention, including the diameter of the dome **302** can be selected as needed for the particular use. Accordingly, embodiments of the dome **302** have an inside diameter, measured at its widest point, of at least 40% greater than the inside diameter of the second end of the

cannula **304**. In some embodiments of the access port **300** of the present invention, the dome **302** has an inside diameter, measured at its widest point, that is between about 1.4 times and 5.0 times greater than the inner diameter of the second end of the cannula **304**. In other embodiments, the dome **302** has an inside diameter, measured at its widest point, that is about 1.4 times, 1.75 times, 2.0 times, 2.5 times, 3.0 times, 3.5 times, 4.0 times, 4.5 times, 5.0 times, or any value therebetween, greater than the inner diameter of the second end of the cannula **304**. Similarly, the length of the dome **302**, measured from its point of attachment with the second end of the cannula to the opposite end of the dome, can vary depending on the particular use. In some embodiments the length of the dome **302** is between about 3.0 cm and 5.0 cm. In other embodiments, the length of the dome **302** is about 3.0 cm, 3.5 cm, 4.0 cm, 4.5 cm, 5.0 cm, or any length therebetween.

**[0040]** The dome **302** can be molded integrally with the cannula **304** as a single integrated unit. Accordingly, the dome **302** can comprise the same material as the cannula **304**. Alternatively, the dome **302** can comprise a more pliable, resilient, material for enhanced flexibility. For example, the dome **302** can comprise rubber, synthetic rubber, silicone, ethylene propylene diene monomer (EPDM), ethylene-propylene copolymer (EP rubber), polyisoprene, polybutadiene, polyurethane, styrene-butadiene, ethylene vinyl acetate (EVA), polychloroprene also referred to as neoprene, perfluoroelastomer exemplified by Kalrez® (Kalrez is a registered trademark of E.I. Du Pont de Nemours and Co. Corp., Wilmington, Del., USA), and the like, or any combination thereof. Some embodiments may comprise a composite, for example, a multilayer structure and/or a plurality of sheets of one or more polymer materials. For example, some embodiments can comprise outer surfaces and/or sheets providing desirable functionality, for example, mechanical strength, abrasion resistance, antimicrobial properties, and the like.

**[0041]** The dome **302** can comprise a self-sealing material to provide a gas tight seal around a variety of shapes and sizes of instruments **330**. When inserted through the dome **302**, the dome **302** sealingly engages with the instrument **330** at the point of insertion. When the instrument is removed from the dome **302**, the dome **302** self-seals to form a zero seal at the site of insertion. In this way, in procedures where insufflation gases are employed for example, embodiments of the access port **300** maintain pneumoperitoneum during multiple instrument exchanges and substantially prevent unintentional loss of pneumoperitoneum. Moreover, embodiments of the dome **302** are deformable without losing physical integrity, and while maintaining substantially gas tight seal with any instrument extending therethrough, as well as self-sealing upon removal of any instruments extending therethrough. Accordingly, embodiments of the dome **302** permit angular or pivotal ranges of movement for the instruments **330** passing through the dome **302**, thereby permitting wide triangulation of instruments inserted therethrough. Due to the expanded diameter and surface area created by the dome **302**, greater spacing apart of multiple instruments **330** is made available to facilitate precise manipulation of instruments **330** during surgical procedures. Accordingly, the surgeon has flexibility in determining the placement and repositioning of instruments in the dome **302** as well as flexibility in selecting the size of instruments **330** to be inserted.

[0042] In some embodiments, the dome 302 comprises a sealable trap door 332 positioned in the dome 302 to allow for removal of excised material, for example, from within the target cavity 314. Exemplary materials which a surgeon may wish to remove from a target cavity 314 during a surgical procedure may include, for example, tissue, tumours, bone fragments, calcified minerals, conduits, foreign materials and the like. In some embodiments the trap door 332 is positioned on the dome 302 substantially opposite the second end of the cannula 304 to easily access the target cavity 314. The trap door 332 can be integrally moulded into the dome 302 or may be affixed. In some embodiments, the trap door 332 is sealable such that a gas-tight seal is restored after opening and closing of the trap door 332, thereby allowing the body cavity to be re-insufflated with gases.

#### Retainer

[0043] Whether inserted in an incision point or a natural orifice, the tissue tract 316 at a target insertion site continually exerts an inward force on the access port 300 of the present invention. This constant inward force can provide sealing of the access port 300 at the insertion site thereby inhibiting escape of insufflation gas from the target cavity. The continual inward force exerted on the access port 300 at the insertion site, however, can also result in difficulty in positioning the access port 300 and/or accidental dislodgement of the access port 300 during a procedure.

[0044] Access ports 300 of the present invention comprise a retainer 306 for anchoring the access port 300 in position when inserted at a target insertion site. The retainer 306 is generally an outwardly facing structure extending around the circumference at the first end or approximate the first end of the cannula 304. When the cannula 304 is inserted through the tissue tract 316, the dome 302 engages with the outside surface 310 of the target cavity 314 in cooperation with the retainer 306, engaged with the inside surface 312 of the target cavity 314, to anchor the access port 300 in position at the insertion site.

[0045] According to one embodiment of the present invention, as illustrated in FIG. 4, the retainer 406 may be a rim outwardly extending continuously or discontinuously around the circumference of the first end of the cannula 404. The retainer 406 may be located flush with the first end of the cannula 404, for example as illustrated in FIG. 4A), or alternatively located along the length of the cannula 404, for example as illustrated in FIG. 4B). In some embodiments, access ports 400 of the present invention may comprise a single retainer 406 outwardly extending around the circumference of the cannula 404. In other embodiments, as illustrated in FIG. 4C) access ports 400 may comprise multiple retainers 406 located along the length of the cannula 404.

[0046] According to some embodiments of the present invention, the retainer can transition between an extended state and a retracted state when in use. For example, when inserted into an insertion site, the retainer is in an extended state. In the extended state, the retainer extends around the circumference of the first end of the cannula so as to engage with the inside surface of the target cavity. During insertion or removal of the first end of the cannula through an insertion site, the retainer is in a retracted state thereby reducing its cross-sectional profile so as to facilitate inser-

tion or removal of the access port as the first end of the cannula passes through the tissue tract.

[0047] In one embodiment of the present invention, as illustrated in FIG. 5, the retainer 506a-c is a resilient flap extending continuously, or discontinuously, around the circumference at the first end or approximate the first end of the cannula 504. During insertion into an insertion site, the first end of the cannula 504 is pushed into an incision or a natural orifice. The tissue tract through which the cannula 504 is pushed, radially compresses the retainer 506a thereby causing the retainer 506a to fold back towards the cannula 504 into the retainer's 506a retracted state. Once the first end of the cannula 504 is inserted through the tissue tract, the retainer 506b reverts to an extended state to engage with the inside surface of the target cavity. A first pull force may be applied to the inserted access port to engage the extended retainer 506b with the inside surface of the target cavity. To remove the access port from a target cavity, a second pull force may be applied to the access port causing the extended retainer 506b to deform and fold outward and away from the first end of the cannula 504. The retainer 506c is thereby transitioned to a retracted state to allow disengagement from the inside surface of the target cavity and enable removal of the access port.

[0048] In another embodiment of the present invention, as illustrated in FIG. 6, the retainer 606 is an inflatable/deflatable balloon cuff provided about the outer circumference at the first end or approximate the first end of the cannula 604. The retainer 606 is in fluid communication with a sealable port 642 which enables the balloon cuff to be inflated. The sealable port 642 may further comprise an integral valve 644 to release fluid from the balloon cuff enabling its deflation. When in use, the retainer 606a can be deflated to a retracted state to facilitate insertion of the first end of the cannula 604 into an insertion site. Once in position, the balloon cuff may be inflated by an air supply delivered through the sealable port 642, to transition the retainer 606b to an extended state. The inflated balloon cuff of the retainer 606b engages with the inside surface of the target cavity to anchor the access port 600 in position. To remove the access port 600 from the insertion site, the balloon cuff of the retainer 606a may be deflated by releasing air through the sealable port 642 to revert the retainer 606a to its retracted state and allowing removal of the access port 600 from the insertion site.

[0049] In other embodiments of the present invention, as illustrated in FIGS. 7, 8, and 9, the access port comprises two pieces which matingly engage to anchor the access port in position at the insertion site. Referring to FIG. 7, the first piece of the access port 700 comprises the cannula 704 and an inner retainer 706a at the first end of the cannula 704. The second piece comprises the dome 702 and a receptacle 718 extending from the dome 702 for engagement with the cannula 704 of the first piece. The second piece of the access port 700 may optionally further comprises an outer retainer 706b located flush with the mating end of the receptacle 718 and opposite from the dome 702. As discussed above, when the cannula 704 of the first piece is inserted through the tissue tract the inner retainer 706a engages with the inside surface of the target cavity. Once the first piece has been inserted into the target cavity, the cannula 704 of the first piece and the receptacle 718 of the second piece matingly engage at the outside surface of the target cavity at the insertion site. When the two pieces of the access port 700 are

matingly engaged, the inner **706a** and outer **706b** retainer cooperate on either side of the tissue tract to provide a tight seal and anchor the access port **700** in position at the insertion site.

[0050] The cannula **704** of the first piece and the receptacle **718** of the second piece each comprise mating apertures for releasable engagement. For example, the cannula **704** may comprise a series of outward-facing ridges and grooves **726** that matingly engage with corresponding inward-facing ridges and grooves **728** displayed on the receptacle **718** extending from the second piece. Alternatively, as illustrated in FIG. **8**, the cannula **804** may comprise outward facing male threads **822** that matingly engage with corresponding female threads **824** displayed on the receptacle **818** extending from the second piece, which screw together for releasable engagement. In some embodiments, the threads **822** and **824** may be aluminum bonded on the respective cannula **804** and receptacle **818**. Those skilled in these arts will be aware of and will understand that other quick connect/disconnect options for releasably engaging the cannula **704** and **804** and the receptacle **718** and **818** can be provided.

[0051] As discussed above, the inner and/or outer retainer of access ports of the present invention can take a variety of forms. For example, as illustrated in FIGS. **7** and **8**, the inner and/or outer retainer **706a**, **806a**, **706b** and **806b**, may be a resilient flap extending continuously, or discontinuously, around the circumference of the respective piece. Alternatively, for example, the inner and/or outer retainer may be one or more rims outwardly extending continuously or discontinuously around the circumference of the respective piece. As illustrated in FIG. **9**, the access port **900** may comprise a combination of different types of retainer **906a** and **906b**. For example, as shown, the inner retainer **906a** may comprise one or more rims outwardly extending circumferentially about the first end of the cannula **904** and the outer retainer **906b** may comprise a resilient flap.

[0052] In order to secure the access port at the insertion site, the outer diameter of the retainer, including an inner retainer or an outer retainer, is larger than the outer diameter of the respective cannula or receptacle. In some embodiments of the access port of the present invention, the outer diameter of the retainer is between about 0.5% to about 50% larger than the outer diameter of the respective cannula or receptacle. In other embodiments of the invention, the width of the retainer measured from the point of attachment to the respective cannula or receptacle to the outside edge of the retainer, is between about 0.5 cm to 2.5 cm. In further embodiments, the width of the retainer is 0.5 cm, 1.0 cm 1.5 cm, 2.0 cm, or any width therebetween.

[0053] Access ports in accordance with the invention can serve many purposes, only one of which is use in minimally-invasive surgical procedures. It should be appreciated by those skilled in the art, that access ports in accordance with the invention can be used wherever access, particularly sealable access, into a body cavity is needed.

[0054] The specific dimensions of access ports in accordance with the invention can be selected as needed. Specifically, it is envisioned that a wide variety of sizes will be available to a user to enable the user to select the most appropriately dimensioned device for the patient and procedure at hand. The overall dimensions of access ports in accordance with the invention can vary, as well as the

relative dimensions of the dome, cannula, and retainer portions of the access port, and the like.

[0055] To gain a better understanding of the invention described herein, the following example is set forth. It will be understood that the example is intended to describe illustrative embodiments of the invention and is not intended to limit the scope of the invention in any way.

## EXAMPLES

### Example 1

[0056] FIG. **10A** illustrates a cross-sectional side view of an example access port **1000** according to an embodiment of the present invention. FIG. **10B** illustrates an end view of the access port **1000** as shown in FIG. **10A**. The access port **1000** is a single integrated unit comprising an elongate cannula **1004** having a first end and a second end, a retainer **1006** coupled to the first end of the elongate cannula **1004** to fix the first end of the cannula **1004** within a tissue tract, and an enclosed dome **1002** extending from the second end of the elongate cannula **1004** for receiving surgical instruments. The access port **1000** can be made of rubber, silicon, or any other resilient, semi-rigid, elastomeric, material, that is biologically compatible. The dimensions of the access port **1000** can be sized for its particular desired use. For use in endoscopic microsurgery procedures in adult humans, for example, the access port **1000** has a cannula **1004** that is between about 1.5 cm to 8.5 cm in length **1034**, and has a diameter **1032** between about 1.5 cm to 4.5 cm. The access port **1000** has a retainer **1006** comprising a resilient flap that extends continuously around the circumference at the first end of the cannula **1004**. The retainer **1006** has a width **1036**, measured from the point of attachment to the first end of the cannula **1004**, of between about 0.5 cm to 2.5 cm. The dome **1002** is shaped as illustrated to enclose the lumen **1030** of the access port **1000**. The dome **1002** has a diameter **1040** of between about 5.0 cm to about 8.0 cm, and a length **1038** of between about 3.0 cm to about 5.0 cm.

[0057] Although the invention has been described with reference to certain specific embodiments, various modifications thereof will be apparent to those skilled in the art without departing from the spirit and scope of the invention. All such modifications as would be apparent to one skilled in the art are intended to be included within the scope of the following claims.

1.-32. (canceled)

33. A surgical access port comprising:

- a. a cannula having a first end and a second end, wherein the first end is for insertion into a target site to maintain a passageway for introduction of one or more surgical instruments;
- b. at least one retainer outwardly extending circumferentially about the first end of the cannula, wherein the retainer engages an inside surface of the target site when the first end of the cannula is inserted;
- c. an elongate receptacle having a mating end for matingly engaging the second end of the cannula; and
- d. a self-sealing dome extending from the receptacle at an end opposite from the mating end, the dome comprising an expanded surface area, the expanded surface area comprising a self-sealing material through which one or more surgical instruments is directly insertable at multiple locations through the expanded surface area of the self-sealing dome, wherein the self-sealing dome

sealingly engages with the one or more surgical instruments introduced therethrough and self-seals when the one or more instruments is removed.

**34.** The surgical access port according to claim **33** wherein the receptacle further comprises a second retainer outwardly extending circumferentially about the mating end of the receptacle.

**35.** The surgical access port according to claim **33**, wherein the cannula and the receptacle comprise a mating aperture for releasable engagement.

**36.** The surgical access port according to claim **35**, wherein the mating aperture is a series of matingly engaging ridges and grooves.

**37.** The surgical access port according to claim **35**, wherein the mating aperture is a series of matingly engaging screw threads.

**38.** The surgical access port according to claim **37**, wherein the screw threads are aluminum bonded on the respective cannula and receptacle.

\* \* \* \* \*

专利名称(译)	经鼻内镜和腹腔镜手术口		
公开(公告)号	<a href="#">US20170086880A1</a>	公开(公告)日	2017-03-30
申请号	US15/285010	申请日	2016-10-04
[标]申请(专利权)人(译)	TANAM医疗		
申请(专利权)人(译)	TANAM MEDICAL INC.		
当前申请(专利权)人(译)	TANAM MEDICAL INC.		
[标]发明人	TANG BAO AMSON BRAD J		
发明人	TANG, BAO AMSON, BRAD J.		
IPC分类号	A61B17/34 A61B90/40 A61M39/02 A61B17/02		
CPC分类号	A61B17/3423 A61B17/0218 A61B90/40 A61M39/0247 A61B2017/3445 A61M2039/0297 A61B2017/349 A61M2039/0261 A61M2039/027 A61M2039/0279 A61B2017/3466 A61B2017/3482 A61B2017/3484 A61M39/02		
优先权	2778976 2012-06-06 CA 61/601863 2012-02-22 US PCT/CA2013/000156 2013-02-20 WO		
其他公开文献	US10092318		
外部链接	<a href="#">Espacenet</a> <a href="#">USPTO</a>		

摘要(译)

提供了在微创外科手术中有用的外科进入端口。进入端口包括套管，该套管限定用于一个或多个外科器械穿过组织道的通道和从套管延伸的穹顶，以提供用于接收一个或多个外科器械的扩张直径。

