



US 20030179448A1

(19) **United States**

(12) **Patent Application Publication**  
**Ramsbottom**

(10) **Pub. No.: US 2003/0179448 A1**

(43) **Pub. Date: Sep. 25, 2003**

(54) **APPARATUS FOR PROVIDING AN IMAGE OF A REMOTE OBJECT ACCESSIBLE ONLY THROUGH AN APERTURE OF FINITE DIAMETER**

(30) **Foreign Application Priority Data**

Nov. 2, 2000 (GB)..... 00268425

**Publication Classification**

(51) **Int. Cl.<sup>7</sup>** ..... **G02B 1/00**

(52) **U.S. Cl.** ..... **359/435; 359/362; 359/434**

(57) **ABSTRACT**

A remote imaging apparatus such as a borescope or endoscope. The apparatus has an image relay means (4) for relaying an image along the main axis (3) from the distal end of the scope and an annular light pipe (1) for transmitting light to the distal end of the scope to illuminate the object to be viewed. At least the inner or outer surface of annular light pipe (1) is surrounded by air.

(76) **Inventor: Andrew Ramsbottom, Essex (GB)**

Correspondence Address:  
**SMITH, GAMBRELL & RUSSELL, LLP**  
**1850 M STREET, N.W., SUITE 800**  
**WASHINGTON, DC 20036 (US)**

(21) **Appl. No.: 10/362,196**

(22) **PCT Filed: Nov. 1, 2001**

(86) **PCT No.: PCT/GB01/04852**

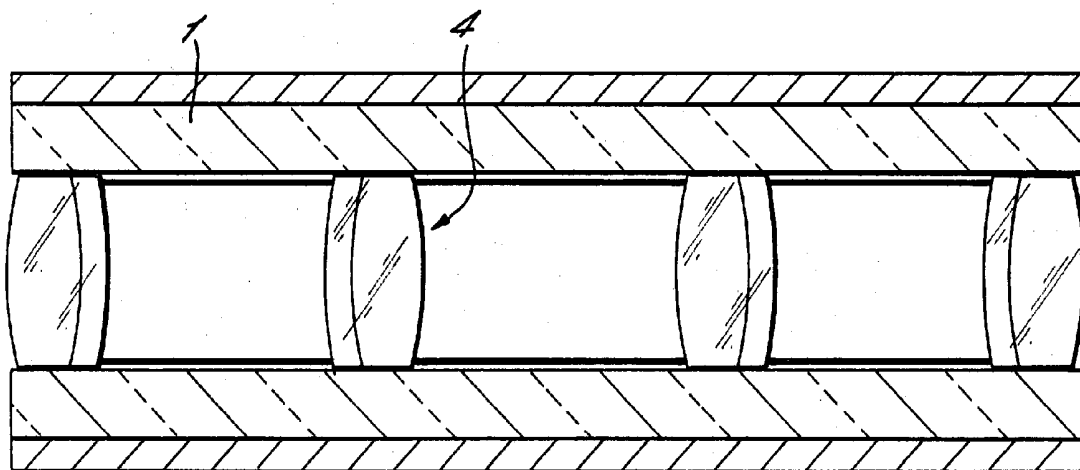

FIG. 1(b).

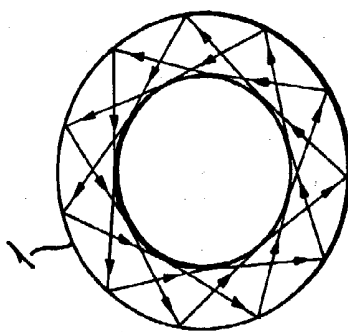
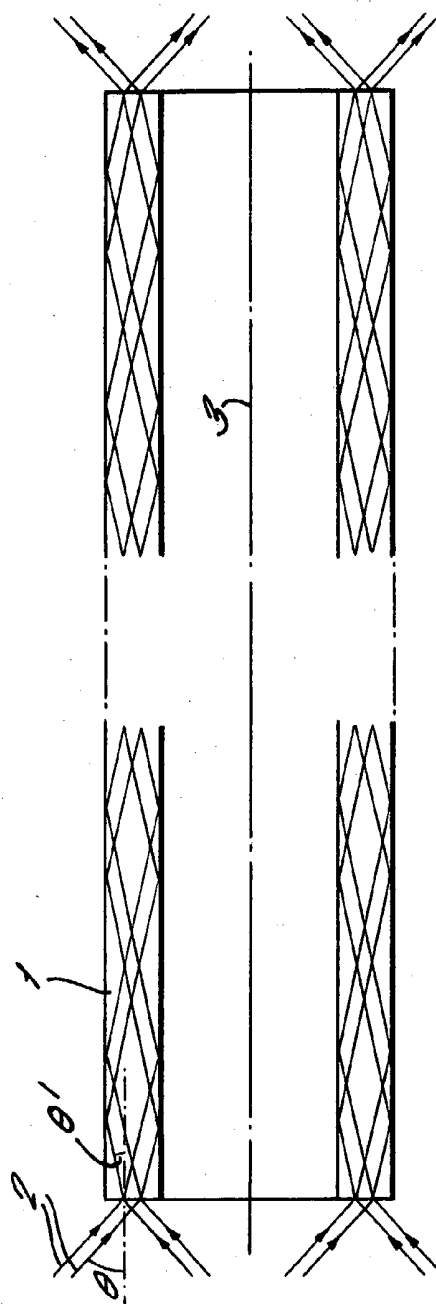

FIG. 1(a).



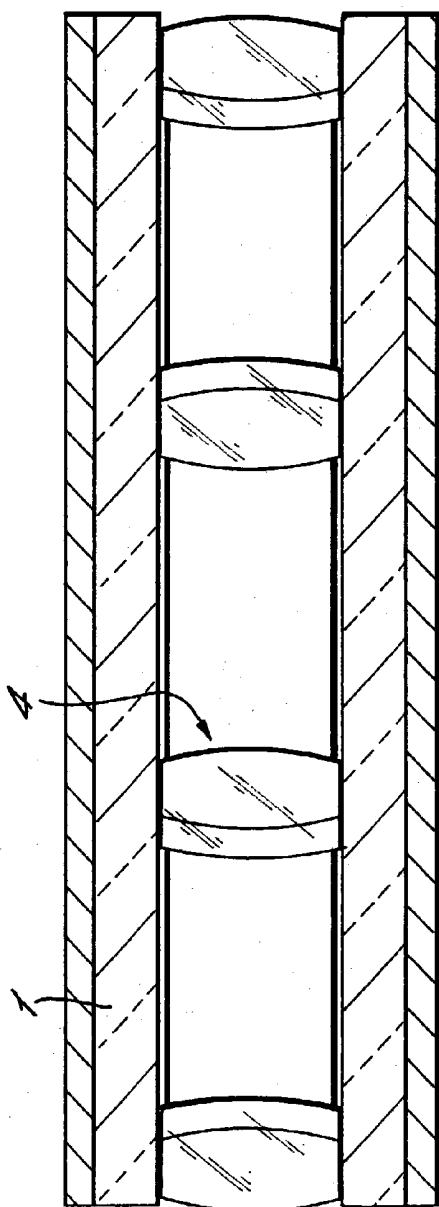

FIG. 2(a).

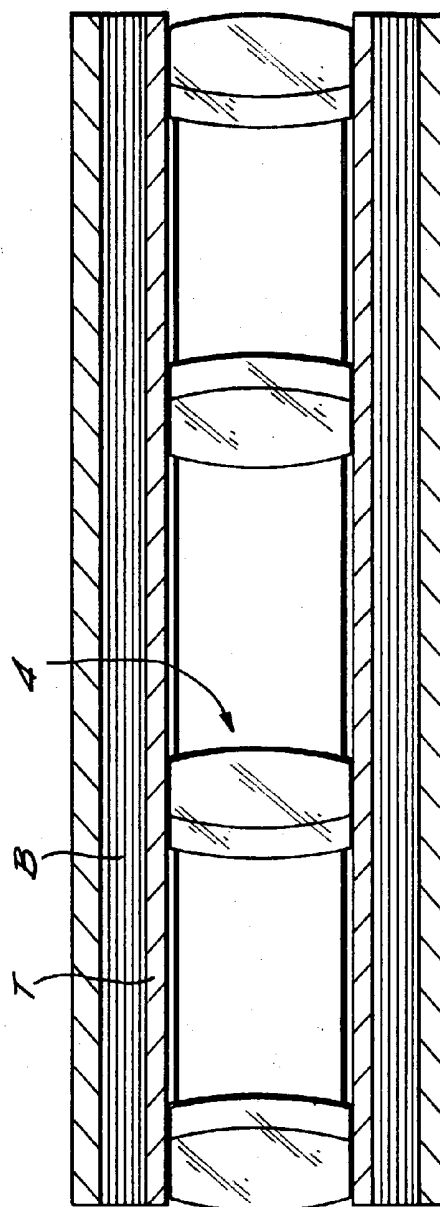
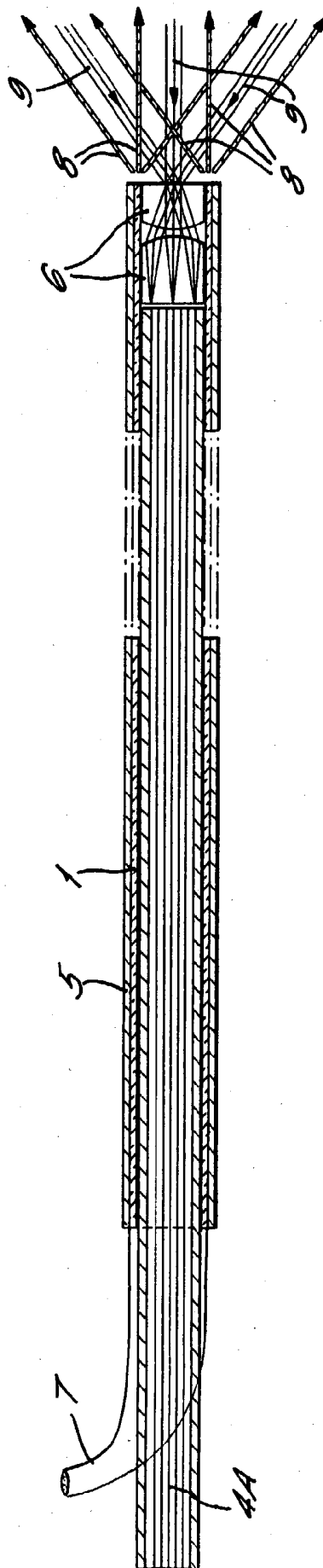

FIG. 2(b).

FIG. 3.



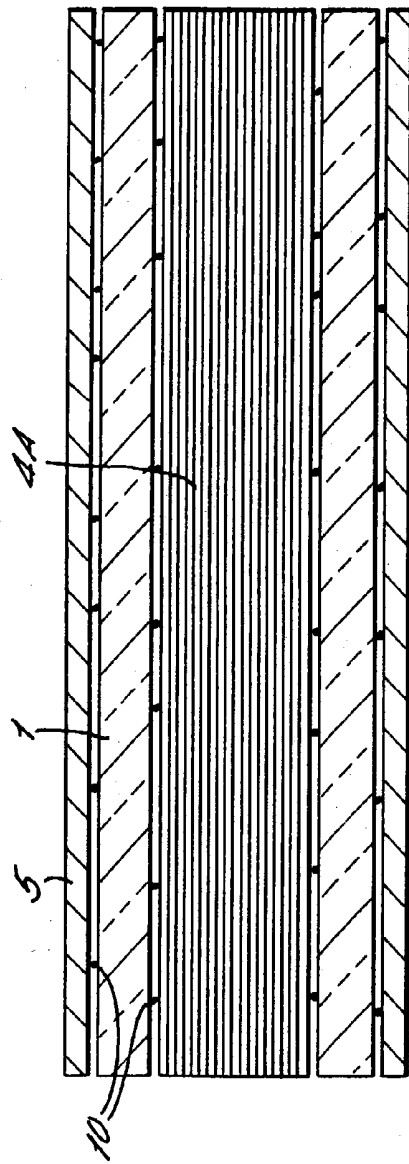

FIG. 4(a).

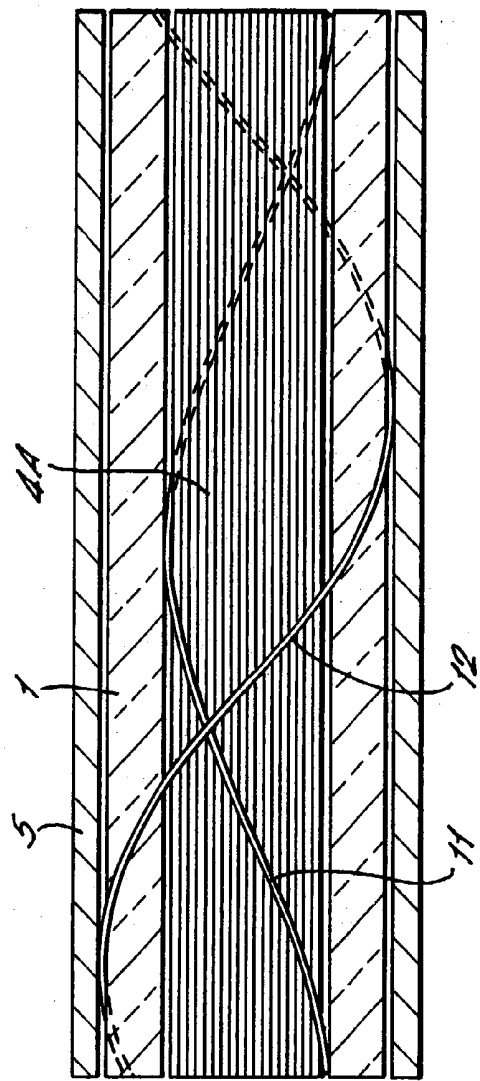
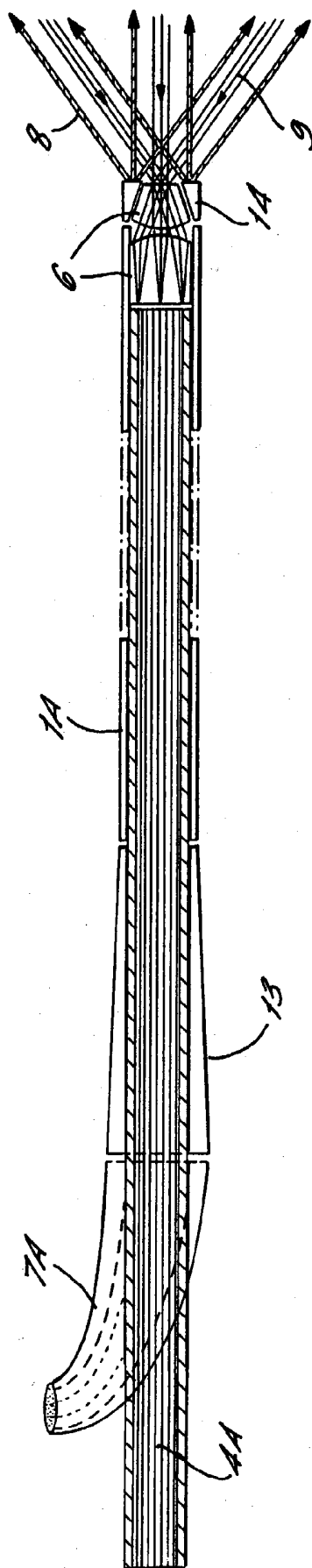
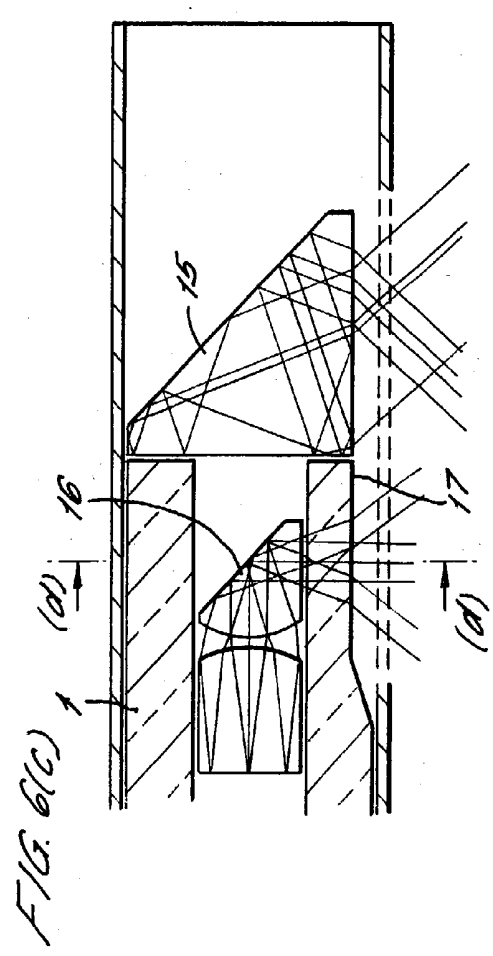
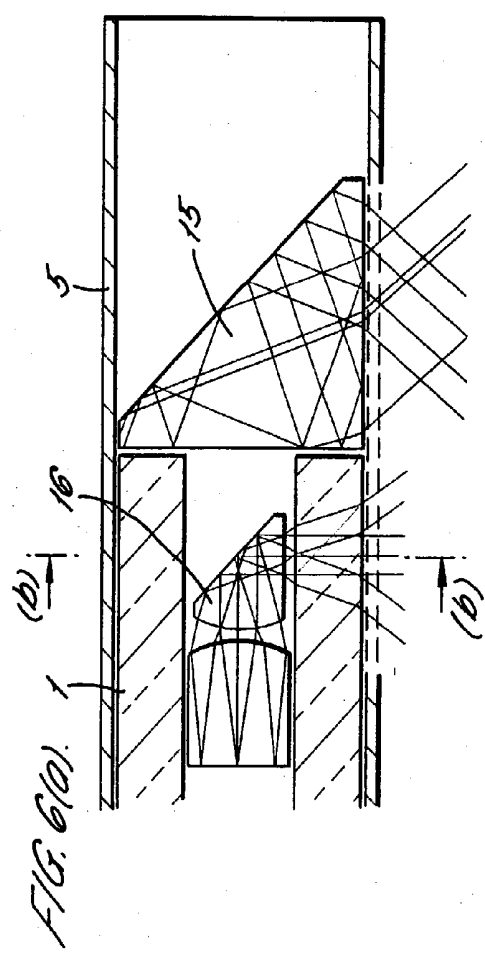
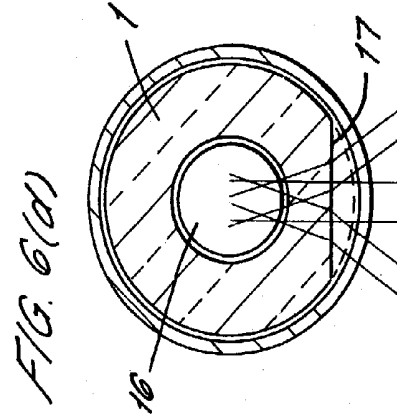
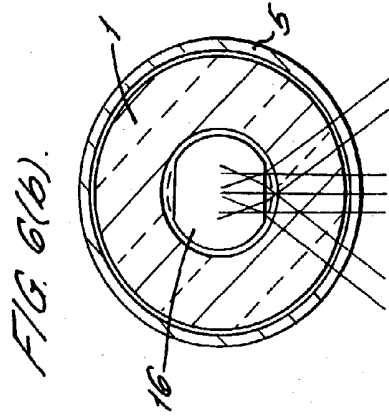

FIG. 4(b).

FIG. 5.





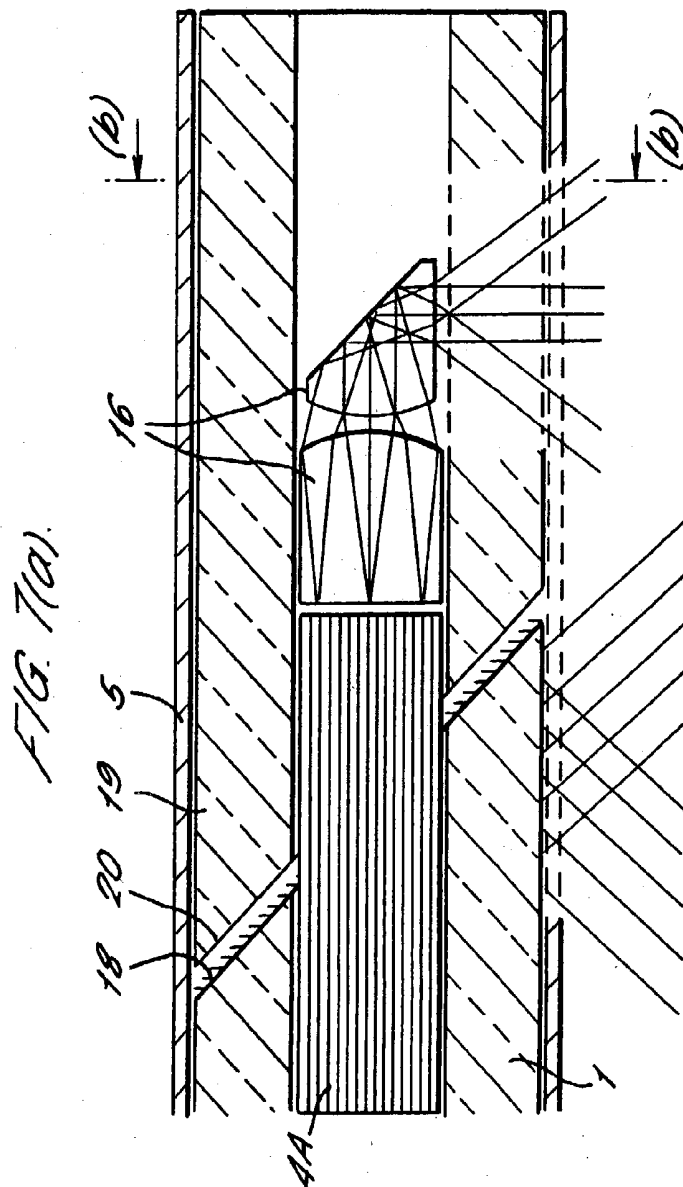
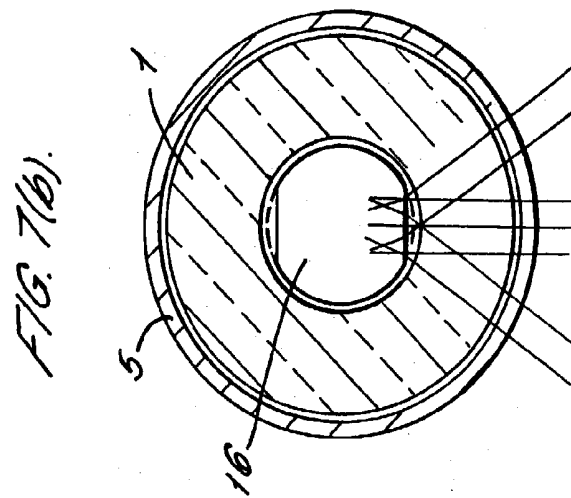

FIG. 7(d).

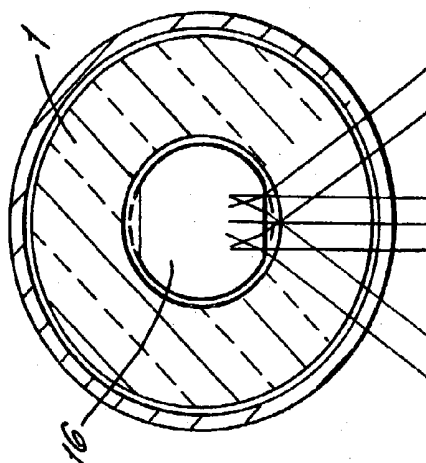
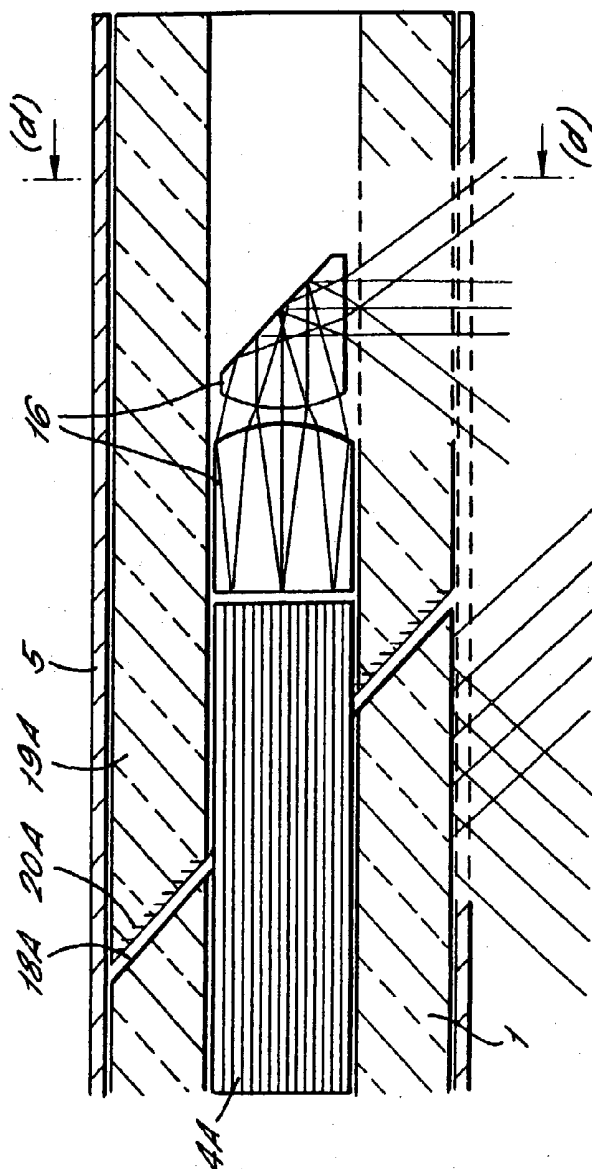

FIG. 7(c).



**APPARATUS FOR PROVIDING AN IMAGE OF A  
REMOTE OBJECT ACCESSIBLE ONLY  
THROUGH AN APERTURE OF FINITE DIAMETER**

[0001] This invention relates to the range of viewing scopes intended to provide an image of a remote object accessible only through an aperture of finite diameter. This includes, for example, borescopes, endoscopes, fibrescopes, and videoscopes.

[0002] Such instruments generally perform two basic optical functions. Firstly they transfer light for illumination purposes from the proximal to the distal end of the scope so as to illuminate the object being viewed. Secondly, they transfer an image of the same object from the distal to the proximal end where this may be viewed by the eye, or by means of an attached or integral camera. Depending on the type of scope there are a number of possible means of image transfer e.g. relay lenses; rod lenses, gradient index (e.g. Selfoc) lenses, flexible coherent fibre bundles, rigid or (semi-rigid) coherent fibre image conduit, CCD or CMOS chip in distal tip. In all of these types of instrument there is a requirement to transmit illumination to the object being viewed. This is usually accomplished by means of a glass fibre bundle consisting of many thousands of individual small diameter (<100 micron) optical fibres packed tightly around the outside of the image transmitting system. Often the mechanical arrangement consists of a 2-tube construction, whereby an inner tube of material is used to support and protect the image transmitting optical system. The illumination fibres are packed around this inner tube inside of an outer protective tube.

[0003] The quality (brightness, resolution, image size) of the image produced by the scope is determined by many design factors however it is generally the case that the larger the diameter of the image transmission system and the greater the amount of luminous flux transmitted by the system then the better is the image quality achievable in respect of either image size, brightness, resolution or some combination of these criteria. Clearly for a given external diameter of scope the amount of luminous flux transmitted by the system can be increased by increasing the number of illumination fibres, however this will-necessarily reduce the diameter of the imaging optical system thereby tending to reduce the overall luminous flux transmitted from distal to proximal end. For any particular system design there will be an optimum ratio of external scope diameter to imaging system diameter which maximises the overall luminous flux transmitted to the image.

[0004] According to the present invention there is provided an apparatus for providing an image of a remote object accessible only through an aperture of finite diameter, the apparatus comprising an elongate body defining a main axis, an image relay means for relaying an image along the main axis from the distal end of the scope, and an annular light pipe surrounding the image relay means for transmitting light to the distal end of the scope to illuminate the object to be viewed; characterised in that at least one of the inner surface or the outer surface of the annular light pipe is surrounded by air.

[0005] The light pipe is essentially a homogeneous block of light transmitting material as opposed to a number of discrete fibres. Although the light pipe will generally have a one piece construction, it may be made up of a small number of homogeneous blocks optically coupled to one another.

[0006] The advantages in replacing the bundle of optical fibres with an annular light pipe are numerous.

[0007] The annular light pipe does not require an inner protective tube allowing it to occupy a proportionally greater part of the limited cross-section available.

[0008] Optical fibres necessarily consist of some dead space caused by gaps between individual fibres and the cladding around each fibre core. This is not the case with an annular light pipe which can therefore transmit more light flux than a fibre bundle of the same cross-sectional area.

[0009] The annular light pipe has the potential to carry more light flux than a fibre bundle of the same cross-sectional area since the numerical aperture is higher. This offers the potential to use light concentrating techniques to increase the amount of light coupled into the annular light pipe as mentioned below.

[0010] When an apparatus is assembled using a bundle of fibres, it is difficult to avoid damaging some of the individual fibres as they are packed tightly around the image relay means. This becomes a proportionally greater problem as the diameter of the apparatus is reduced.

[0011] An annular light pipe is easier to handle than a bundle of optical fibres thereby greatly facilitating the assembly process.

[0012] The ability of the annular light pipe to transmit light is dependent upon the efficiency of the total internal reflection within the annular light pipe. This, in turn, is dependent upon the difference in the refractive index of the annular light pipe and the surrounding medium. To achieve the required differential in refractive indices at least the inner surface or the outer surface of the annular light pipe is surrounded by air. Of course, the annular light pipe will have to be externally supported and also has to provide support internally for the image relay means. This can be achieved if the annular light pipe is provided internally and/or externally with a support which contacts the annular light pipe only at a number of discrete locations. The support material preferably has a lower refractive index than that of the annular light pipe. The support may, for example, be a powder distributed internally and/or externally of the annular light guide, or may be one or more strips of fibrous material wound internally and/or externally of the annular light pipe.

[0013] As an alternative to the air gap, one of the inner surface or the outer surface of the annular light pipe may be coated with a layer of material having a lower refractive index than the material of the annular light pipe.

[0014] In order to increase the amount of light being transmitted through the annular light pipe, the invention may make use of a light flux concentrator. This takes the form of a frusto-conical light pipe which is coaxial with the annular light pipe and has a central axial bore corresponding to the bore of the annular light pipe, the outer diameter of the frusto-conical light pipe decreasing towards the annular light pipe and being substantially equal to the outer diameter of the annular light pipe at the interface between the annular light pipe and the frusto-conical light pipe. This allows a greater amount of flux to be coupled into the annular light pipe.

[0015] The flux will, however, be distributed over a wider angular range. This is a well understood and fundamental limitation of such light concentrators and there is generally an inverse relationship between the spatial distribution and annular distribution achieved for given light flux through a frusto-conical light pipe. At the distal end, the light would be emitted from the annular light pipe over a correspondingly larger angular distribution. Depending on the field of view, this may or may not be desirable. If it is not desirable, the angular distribution can be reduced by providing a distal light guide adjacent to the distal end of the annular light pipe and having an outer diameter equal to the outer diameter of the annular light pipe, and an inner diameter at its proximal end which is equal to the inner diameter of the annular light pipe and which progressively decreases towards the distal end. This is feasible since the diameter of the image relay means immediately adjacent to the distal end is generally smaller than its diameter away from the distal end. This leaves some unused space at the distal end for the tapered distal light guide as described.

[0016] The invention is applicable to a lateral viewing apparatus in which light is emitted and the images received in a direction substantially  $90^\circ$  to the viewing direction. In this case, the annular light pipe is provided with a window through which the image is transmitted to the image relay means. In order to reduce the amount of astigmatism, the external surface of the annular light pipe at the window may be polished flat.

[0017] A further arrangement for a lateral viewing apparatus is provided by the light guide terminating at a face which is at substantially  $45^\circ$  to the main axis and is associated with a reflective coating.

[0018] Examples of apparatus constructed in accordance with the present invention will now be described with reference to the accompanying drawings, in which:

[0019] FIGS. 1(a) and 1(b) are schematic axial section and end illustrations respectively of the technical principal underlying the present invention;

[0020] FIG. 2(a) is a schematic cross-section of the present invention and FIG. 2(b) is a similar view of the prior art for comparative purposes;

[0021] FIG. 3 is a schematic cross-section of an apparatus in accordance with the present invention;

[0022] FIG. 4(a) is a schematic cross-section through a portion of the apparatus showing a first way of supporting an annular light pipe and image relay means;

[0023] FIG. 4(b) is a view similar to FIG. 4(a) showing a second way of supporting the annular light pipe and image relay means;

[0024] FIG. 5 is a schematic cross-section similar to FIG. 3 of a further apparatus in accordance with the present invention having a light flux concentrator;

[0025] FIG. 6(a) is a schematic axial cross-section of a distal end of a further example of an apparatus in accordance with the present invention;

[0026] FIG. 6(b) is a cross-section through line (b) (b) in FIG. 6(a);

[0027] FIGS. 6(c) and 6(d) are views corresponding to FIGS. 6(a) and 6(b) respectively showing a further example of an apparatus in accordance with the present invention;

[0028] FIGS. 7(a) and 7(b) are views corresponding to FIGS. 6(a) and 6(b) respectively showing a further example of an apparatus in accordance with the present invention; and

[0029] FIGS. 7(c) and 7(d) are views corresponding to FIGS. 6(a) and 6(b) respectively showing a further example of an apparatus in accordance with the present invention.

[0030] The invention can be applicable to any apparatus such as a borescope, endoscope, fibrescope or videoscope. Such an apparatus may either be of rigid construction or may be flexible. The invention essentially resides in replacing a conventional annular bundle of fibres in such a device with an annular light pipe 1. The technical principle governing the operation of the light pipe will now be described with reference to FIGS. 1(a) and 1(b).

[0031] The elongate annular light pipe 1 is shown surrounded inside and out by air. Light 2 is coupled into the proximal end of the light pipe 1. This light is efficiently contained within the light pipe 1 by means of total internal reflection from the air-glass interfaces. FIG. 1(a) shows the typical path of meridional light rays (rays travelling within the plane of the drawing) incident on the end of the light pipe at an angle  $\theta$  with respect to the direction of the pipe axis. It can be shown that any ray incident on the end of the pipe within an angle  $\theta$  will be thus contained within the guide providing that  $\sin \theta \leq \sqrt{n'^2 - 1}$  where  $n'$  is the refractive index of the pipe material. This implies that a material with a refractive index of 1.414 ( $\sqrt{2}$ ) or greater will effectively contain meridional light rays incident from any acute angle to the pipe axis 3.

[0032] FIG. 1(b) shows an end-on view of the pipe 1 and the path of a typical skew ray (a ray direction with both a meridional component and a component out of the plane of the drawing in FIG. 1(a)). Clearly any skew ray that is incident at an angle to the pipe axis 3 of  $\theta$  or less, where  $\theta$  is defined by the equation above, will be incident on the pipe wall within the material at an angle to the surface normal greater than that of a meridional ray incident from a similar angle to the pipe axis 3. Hence any skew ray satisfying the above equation must also be contained efficiently within the pipe 1.

[0033] The quantity  $\sin \theta (=n' \sin \theta')$  in the above equation defines the maximum 'numerical aperture' of the light ray bundle. For most common optical materials ( $n > 1.414$ ) the maximum numerical aperture is greater than 1.

[0034] A cross-section illustrating schematically one possible design of a scope body containing a pipe 1 of this type is shown in FIG. 2(a). For comparison a conventional borescope cross-section is shown of FIG. 2(b). The pipe 1 is replacing both the conventional fibre bundle B and the inner protective lens tube T. The example shown in FIG. 2 shows a conventional relay lens image transfer system 4 however the pipe 1 could just as well act as the protective enclosure for any of the other types of image transfer system referred to earlier.

[0035] FIG. 3 is a schematic showing the apparatus in greater detail than in FIG. 2(a). The apparatus is a device

such as a borescope which is configured as a forward viewing device. The device comprises a hollow cylindrical main body **5** with imaging lenses **6** at its distal end. An image relay means, in this case a fibre image conduit **4A** extends axially away from the distal end along the centre of the body **5**. An annular light pipe **1** extends proximally from the distal end and surrounds the imaging lenses **6** and fibre image conduits **4A** at least along a portion of its length. An illumination fibre bundle **7** consisting of a plurality of optical fibres is coupled to the proximal end of the light pipe **1**. The opposite end of the illumination fibre bundle is connected to the light source.

[0036] In use, light from the light source is transmitted along the illumination fibre bundle **7** and subsequently along the annular light pipe **1** to be emitted from the distal end of the device as rays **8** to illuminate the image. The image received by the imaging lenses is represented by lines **9**. This image is relayed distally along the fibre image conduit so as to be viewed by the eye of an observer or by a camera in the conventional manner.

[0037] In principle the annular light pipe **1** as described above can transmit light with extremely high efficiency, since the process of total internal reflection is close to 100% efficient for a smooth or polished surface. Clearly any absorption of light by the material would reduce the efficiency. This can be avoided by choosing a material for which the absorption at the wavelength of intended use is low (e.g. at visible wavelengths fused silica, high transmission optical glass or plastic could be used).

[0038] Loss of light may also occur where any material touches or comes into close contact with the internal or external surfaces of the guide. Obviously this must occur to some extent as the pipe **1** has to be supported in some way and furthermore is acting as a support for the image relay means **4**, **4A**. This loss can however be reduced to negligible level by a number of possible means illustrated in the various embodiments described below.

[0039] Possible Embodiments

[0040] 1) Materials: Suitable high transmission materials for an annular light pipe include fused silica, optical glass, acrylic (poly-methyl-methacrylate). Acrylic or other plastic materials have the advantage of being highly flexible however do not have as high transmission as many types of optical glass or fused silica.

[0041] 2) Uncoated Capillary Material

[0042] The principle is essentially as described above. However in order to reduce light loss where anything touches the pipe a number of possible techniques can be implemented.

[0043] a) If all surfaces are clean and free of grease then the pipe will only make contact on its internal or external surfaces at isolated single points. Light will only escape from the guide where surfaces are adjacent to within less than 1 wavelength ( $\approx 0.5$  microns for visible light). This means that the effective contact area will be small as a proportion of the pipe surface area and little light flux will be lost.

[0044] b) The capillary could be protected by means of a material of lower refractive index.

[0045] Suitable materials might be fluoropolymers such as PTFE, Teflon etc. Such materials have a low refractive index ( $\approx 1.3$ ) and will therefore maintain the light-guiding properties of a pipe made of material of higher refractive index all be it at a lower numerical aperture. FIG. 4(a) shows one possible arrangement whereby the pipe **1** is spaced from both the image relay means (in this case a fibre image conduit **4A**) and the housing **5** by means of a light coating of fine particles **10**, e.g. Teflon powder. These contact the pipe **1** only at discrete points and even at those points would substantially preserve the light-guiding properties of the pipe due to the low refractive index of the Teflon. An alternative arrangement is shown in FIG. 4(b) whereby a thin Teflon fibre **11** is coiled around the image relay means **4A** and a second fibre **12** is coiled around the capillary so as to provide a low refractive index protective barrier.

[0046] 3) Coated Capillary Material

[0047] Either the inner surface or the outer surface of the pipe itself could consist of a light transmitting material with a thin cladding layer of lower refractive index material on either the external, internal or both surfaces. For such an arrangement it can be shown that the maximum numerical aperture of the pipe is given by:  $\sin \theta = \sqrt{n_{\text{core}}^2 - n_{\text{cladding}}^2}$ . Suitable material combinations, could for example consist of a fused silica capillary ( $n=1.46$ ) with a fluoropolymer cladding layer ( $n=1.3$ ) for which the numerical aperture would be 0.66, or alternatively an acrylic capillary core ( $n=1.49$ ) with a fluoropolymer cladding would have a numerical aperture of 0.73. These numerical aperture values are similar to, or greater than those of typical glass fibre bundle light guides, and would therefore be entirely adequate for transmitting light coupled directly from such a bundle. Using a glass core material of higher refractive index would result in a still higher numerical aperture.

[0048] A further advantageous feature of using a fluoropolymer cladding on a rigid material such as glass or silica is the additional strength and flexibility imparted to the structure. This is due to the prevention of the formation of micro-cracks in the stressed glass surface which could lead to the breakage of the light guide when placed under stress.

[0049] A further example of apparatus in accordance with the present invention is shown in FIG. 5. Most of the features of this example including the image relay means **4A** and the imaging lenses **6** are generally the same as described previously. Further, although FIG. 5 does not show a housing **5**, this will be present in use.

[0050] One difference in this example is that the light pipe **1(a)** does not extend as far in the distal or proximal directions as the light pipe **1** of the previous example. Instead, at the proximal end, an outwardly tapering flux concentrator **13** is provided. This has an outer diameter equal to that of the pipe **1A** at its distal end, and its outer diameter increases proximally. The fibre bundle **7A** can consequently be larger than the fibre bundle **7** used for the example described with reference to FIG. 3.

[0051] The fibre optic bundle will emit light over an area defined by the diameter of the flux concentrator and over an angle (or numerical aperture) determined by the combination of construction materials used or the input numerical aperture of the illumination from the light source (whichever is the lesser). Typical values for standard commercially

available light guides are: diameter=4.5 mm; numerical aperture=0.6. The flux concentrator **13** enables light to be coupled from a standard optical fibre light bundle **7A** and compressed down to a smaller area to match the size of light pipe **1A**. This will couple a greater amount of flux into the pipe **1A** than simply coupling from the fibre bundle directly into the pipe **1** as shown in **FIG. 3**. The flux will however be distributed over a wider angular range. This is a well understood and fundamental limitation of such light concentrators and there is generally, an inverse relationship between the spatial distribution and angular distribution achieved for a given light flux through a conical light concentrator. If the cross sectional areas of the input and output faces of the concentrator are  $A_i$  and  $A_o$  respectively, the input and output numerical apertures ( $NA_i$  and  $NA_o$ ) are related by the equation:

$$A_o \cdot NA_o^2 = A_i \cdot NA_i^2$$

[0052] If the maximum numerical aperture of the light pipe is higher than that of the fibre bundle, then this does allow the collection and transportation of light flux from a bundle of larger area than that of the light pipe.

[0053] At the distal end the light would be emitted from the light pipe **1** over a correspondingly larger angular distribution. Depending on the field of view this may or may not be desirable. However, it is quite feasible to reduce the angular distribution of the emitted light flux. This can be achieved by providing, adjacent to the distal end of the light pipe **1A** a tapered light guide which has a constant external diameter equal to that of the light pipe **1A** and inner diameter which decreases towards the distal end. As can be seen from **FIG. 5**, the distal imaging lens is required to have a corresponding tapered shape.

[0054] **FIGS. 6(a-d)** show two possible distal tip arrangements which would enable the use of an annular light pipe with a lateral viewing (90 degrees direction of view) scope. These arrangements use a 90° prism **15** with a cylindrical profile to couple light out of the capillary and direct the illumination in the 90° viewing direction. The view of the imaging system is achieved by means of a 90° prismatic lens **16**. In **FIGS. 6(a)** and **(b)** this is truncated such that the output transmitting surface and the reflecting surface of the prism are both flat and thus do not contribute any optical aberrations. In this configuration the object is viewed through the side face of the light pipe **1** guide. This will have the effect of viewing the object through a cylindrical shaped window and will introduce a small amount of astigmatic power. Depending on the diameter and thickness of the pipe, and the optical specifications of the instrument this may or may not represent a noticeable amount of astigmatic aberration. If the amount of astigmatism is significant then an alternative means of achieving a lateral direction of view is shown in **FIGS. 6(c)** and **(d)**. In this case a 90° viewing prism with a cylindrical profile to match the internal cylindrical curve of the capillary is used and the view is through a small section of the pipe **1** with a flat area **17** polished on to the outside curve.

[0055] **FIGS. 7(a)-(d)** show two further possible distal tip arrangements which would enable the use of an annular light pipe with a lateral viewing (90° direction of view) scope. These arrangements use the same fibre image conduit **4A** as in **FIG. 3**, and the same 90° prismatic lens **16** of **FIG. 6**. However, whereas **FIG. 6** uses a prism **15** to direct light in

the 90° viewing direction, the arrangement of **FIG. 7(a)** shows the light pipe **1** terminating at an oblique surface **18** at 45° to the main axis. The oblique face **18** is a reflective surface provided by means of a reflective mirror coating on the cut and polished edge of the light guide itself. Positioned distally of the light guide **1** is a support tube **19** having an oblique face **20** which is complementary to the oblique face **18** of the light guide **1**. This support tube **19** supports the distal end of the fibre image conduit **4A** and the prismatic lens **16**.

[0056] An alternative arrangement is shown in **FIGS. 7(c)** and **7(d)**. In this case, the light guide **1** has an oblique face **18A** at 45° as before, and a support tube **19A** is again provided in the same way that it was in **FIG. 7(a)**. However, in this case, the oblique face **28** of the support tube **19A** is provided with the reflective surface. This support tube **19A** should be made of glass, metal or plastic as convenient, with a reflective coating and may or may not be attached to the light guide **1** using optical cement. The use of optical cement has the advantage of reducing the requirement for a smooth, highly polished surface on the cut edge of the light guide **1**.

[0057] In both of the arrangements shown in **FIGS. 7(a)-(d)**, some of the 90° directed illumination may be obstructed by the image relay means for **A**. For example, if this consists of the coherent fibre image guide **4A** as shown in **FIGS. 7(a)-(d)**, this will usually be protected by a plastic coating. It is possible to remove the coating in the region of the illumination so as to allow the 90° directed illumination to pass through the fibre image conduit **4A** unobstructed. Alternatively, if the image relay means is a relay lens system, it may be possible, by careful design of the relay lens system and the prismatic lens **16** to arrange for the 90° directed illumination to pass through an air space between lenses of the image relay means thereby avoiding any obstruction to the illumination.

1. An apparatus for providing an image of a remote object accessible only through an aperture of finite diameter, the apparatus comprising an elongate body defining a main axis, an image relay means for relaying an image along the main axis from the distal end of the scope, and an annular light pipe surrounding the image relay means for transmitting light to the distal end of the scope to illuminate the object to be viewed; characterised in that at least one of the inner surface or the outer surface of the annular light pipe is surrounded by air.

2. An apparatus according to claim 1, wherein the or each surface surrounded by air is provided with a support which contacts the annular light pipe only at a number of discrete locations.

3. An apparatus according to claim 2, wherein the support material has a lower refractive index than that of the annular light pipe.

4. An apparatus according to claim 2 or claim 3, wherein the support is provided by a powder distributed internally and/or externally of the annular light guide.

5. An apparatus according to claim 2 or claim 3, wherein the support is one or more strips of fibrous material wound internally and/or externally of the annular light pipe.

6. An apparatus according to claim 1, wherein the inner surface or the outer surface of the light pipe is coated with a layer of material having a lower refractive index than the material of the annular light pipe.

7. An apparatus according to any one of the preceding claims, further comprising a frusto-conical light pipe which is coaxial with the annular light pipe and has a central axial bore corresponding to the bore of the annular light pipe, the outer diameter of the frusto-conical light pipe decreasing towards the annular light pipe and being substantially equal to the outer diameter of the annular light pipe at the interface between the annular light pipe and the frusto-conical light pipe.

8. An apparatus according to any one of the preceding claims, further comprising a distal light guide adjacent to the distal end of the annular light pipe and having an outer diameter equal to the outer diameter of the annular light pipe, and an inner diameter which at its proximal end is equal to the inner diameter of the annular light pipe and which progressively decreases towards the distal end.

9. An apparatus according to any one of the preceding claims arranged such that light is emitted and the images are received in a direction substantially  $90^\circ$  to the viewing direction in which the annular light pipe is provided with a window through which the image is transmitted to the image relay means.

10. An apparatus according to claim 9, wherein the external surface of the annular light pipe at the window is polished flat.

11. An apparatus according to claim 9 or claim 10, wherein the light guide terminates at a face which is at substantially  $45^\circ$  to the main axis and is associated with a reflective coating.

\* \* \* \* \*

专利名称(译)	用于提供仅通过有限直径的孔可访问的远程对象的图像的设备		
公开(公告)号	<a href="#">US20030179448A1</a>	公开(公告)日	2003-09-25
申请号	US10/362196	申请日	2001-11-01
[标]申请(专利权)人(译)	拉姆斯博顿ANDREW		
申请(专利权)人(译)	拉姆斯博顿ANDREW		
当前申请(专利权)人(译)	KEYMED ( 医疗及工业设备 ) 有限公司		
[标]发明人	RAMSBOTTOM ANDREW		
发明人	RAMSBOTTOM, ANDREW		
IPC分类号	A61B1/00 G02B23/24 G02B23/26 G02B1/00		
CPC分类号	G02B23/26		
优先权	2000026842 2000-11-02 GB		
外部链接	<a href="#">Espacenet</a> <a href="#">USPTO</a>		

摘要(译)

远程成像设备，例如管道镜或内窥镜。该装置具有图像中继装置（4），用于沿着主轴（3）从示波器的远端中继图像，以及环形光管（1），用于将光传输到示波器的远端以照射物体。被观看。至少环形光管（1）的内表面或外表面被空气包围。

