



(19) **United States**

(12) **Patent Application Publication** (10) **Pub. No.: US 2002/0092533 A1**

Boyd et al. (43) **Pub. Date: Jul. 18, 2002**

(54) **DEVICES AND METHODS FOR PORT-ACCESS MULTIVESSEL CORONARY ARTERY BYPASS SURGERY**

(52) **U.S. Cl. 128/898**

(76) **Inventors: Stephen W. Boyd**, Redwood City, CA (US); **Alan R. Rapacki**, San Francisco, CA (US); **Matthias Vaska**, Palo Alto, CA (US); **Brian S. Donlon**, Los Altos Hills, CA (US); **William S. Peters**, Woodside, CA (US)

(57) **ABSTRACT**

Surgical methods and instruments are disclosed for performing port-access or closed-chest coronary artery bypass (CABG) surgery in multivessel coronary artery disease. In contrast to standard open-chest CABG surgery, which requires a median sternotomy or other gross thoracotomy to expose the patient's heart, port-access CABG surgery is performed through small incisions or access ports made through the intercostal spaces between the patient's ribs, resulting in greatly reduced pain and morbidity to the patient. In situ arterial bypass grafts, such as the internal mammary arteries and/or the right gastroepiploic artery, are prepared for grafting by thoracoscopic or laparoscopic take-down techniques. Free grafts, such as a saphenous vein graft or a free arterial graft, can be used to augment the in situ arterial grafts. The graft vessels are anastomosed to the coronary arteries under direct visualization through a cardioscopic microscope inserted through an intercostal access port. Retraction instruments are provided to manipulate the heart within the closed chest of the patient to expose each of the coronary arteries for visualization and anastomosis. Disclosed are a tunneler and an articulated tunneling grasper for rerouting the graft vessels, and a finger-like retractor, a suction cup retractor, a snare retractor and a loop retractor for manipulating the heart. Also disclosed is a port-access topical cooling device for improving myocardial protection during the port-access CABG procedure. An alternate surgical approach using an anterior mediastinotomy is also described.

Correspondence Address:

Phillip S. Johnson
Johnson & Johnson
1 Johnson & Johnson Plaza
New Brunswick, NJ 08933-7003 (US)

(21) **Appl. No.: 09/982,502**

(22) **Filed: Oct. 19, 2001**

Related U.S. Application Data

(60) Division of application No. 09/487,024, filed on Jan. 19, 2000. Continuation-in-part of application No. 08/281,891, filed on Jul. 28, 1994, now Pat. No. 5,735,290, which is a continuation-in-part of application No. 08/023,778, filed on Feb. 22, 1993, now Pat. No. 5,452,733.

Publication Classification

(51) **Int. Cl.⁷ A61B 19/00**

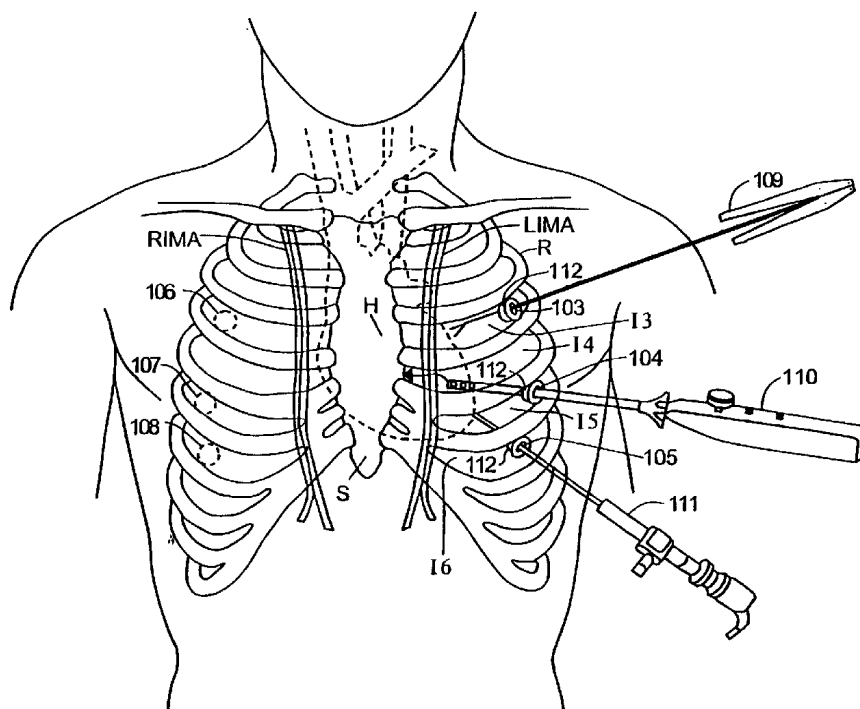

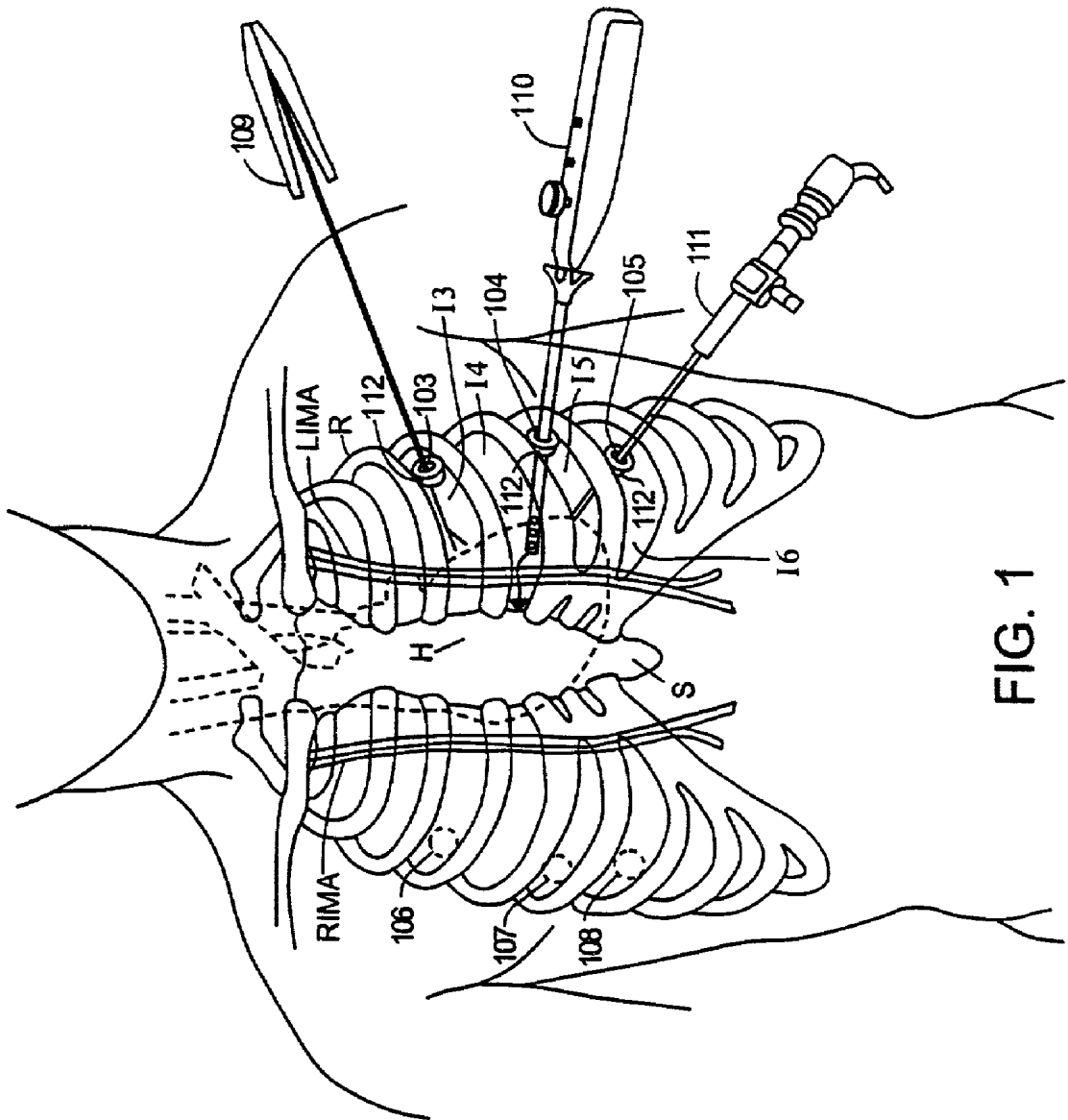

FIG. 1

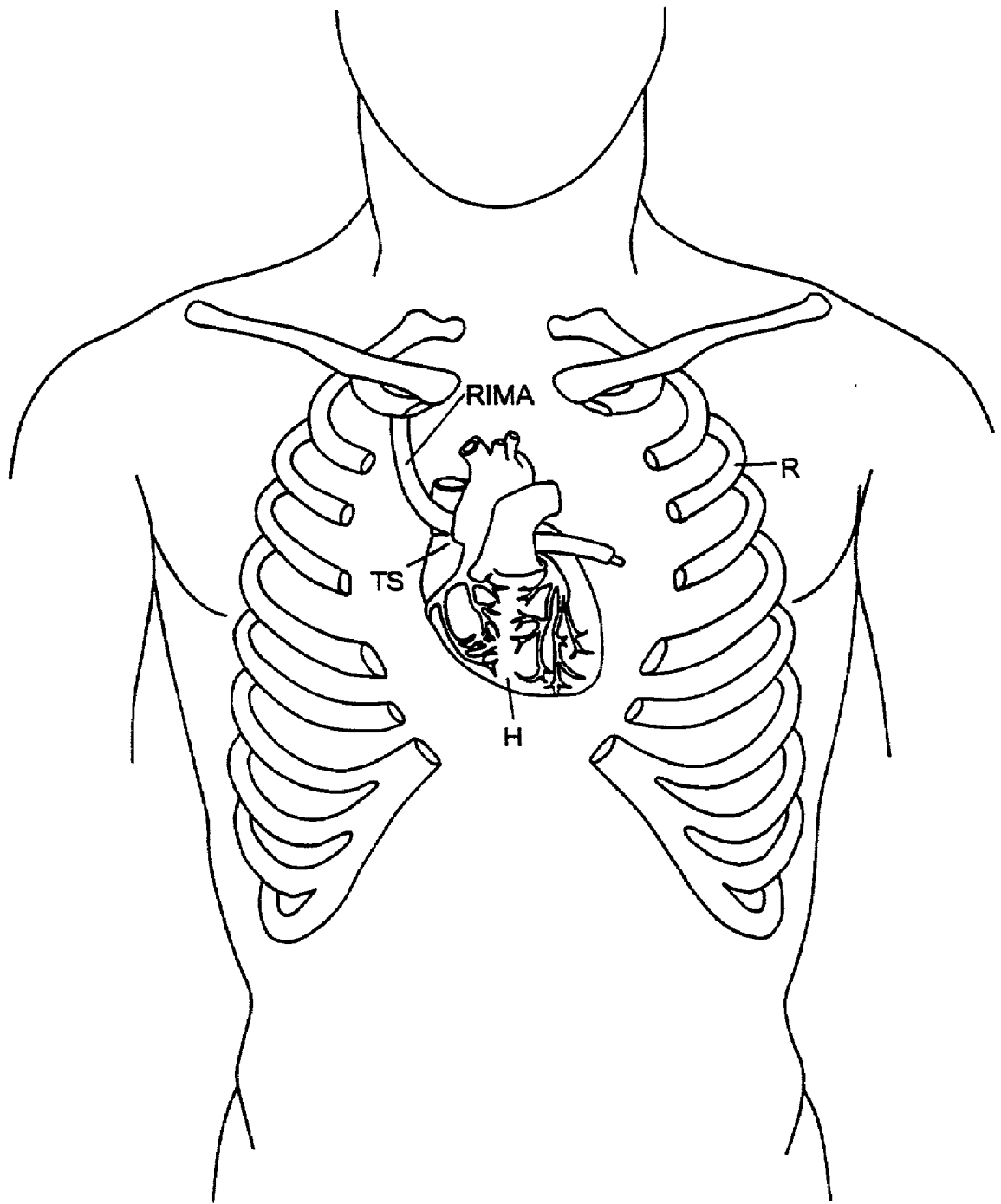

FIG.2

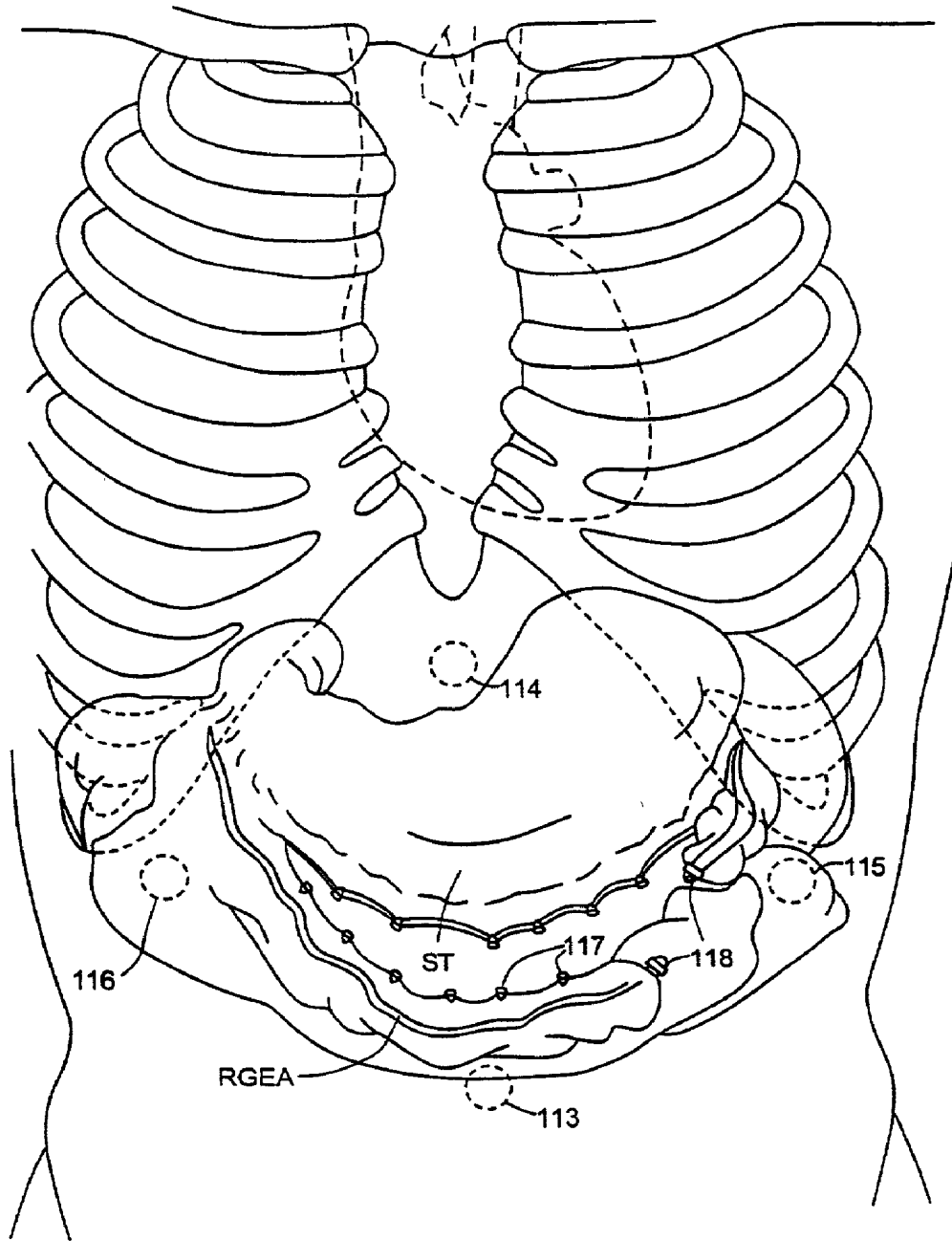

FIG.3

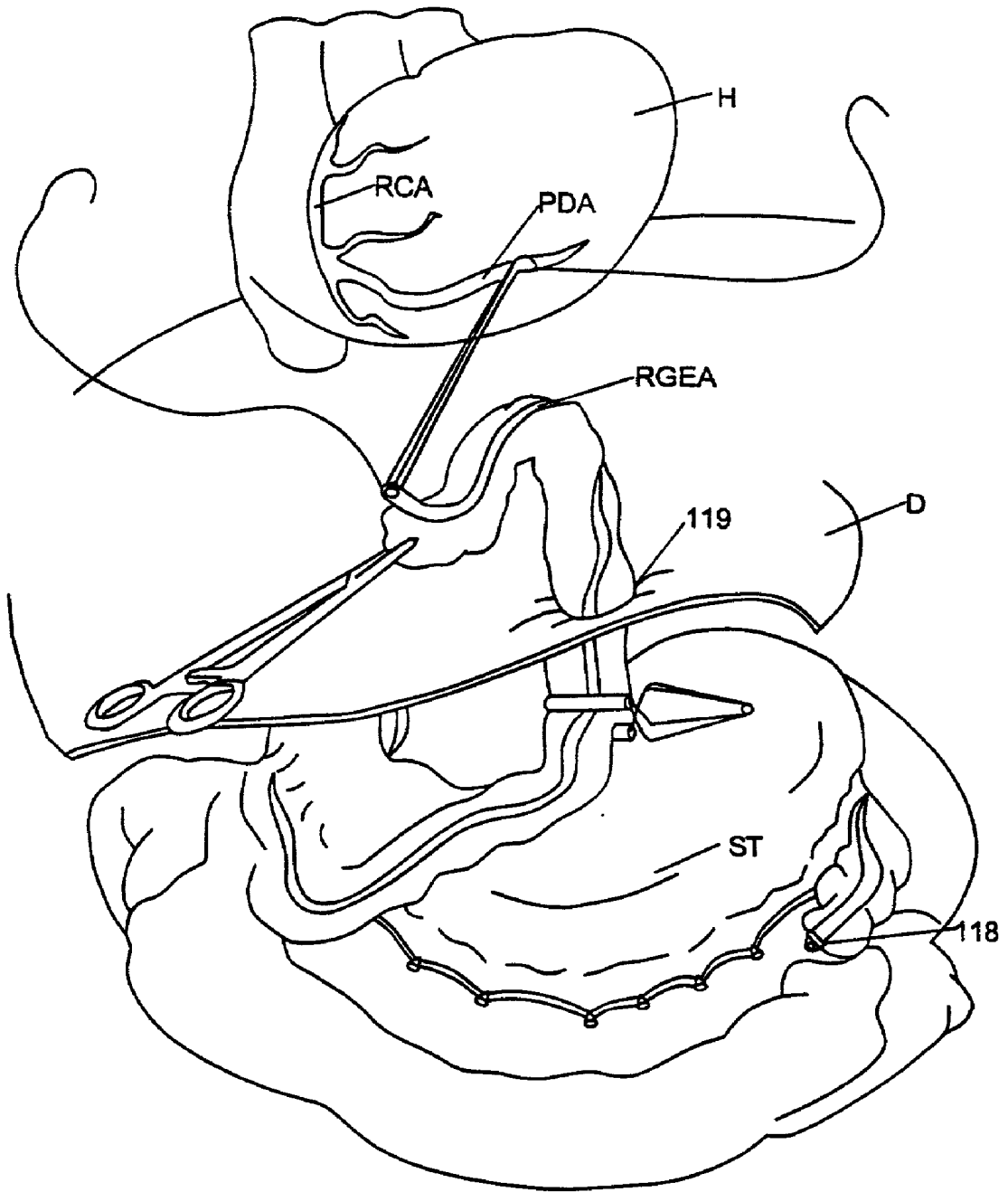

FIG.4

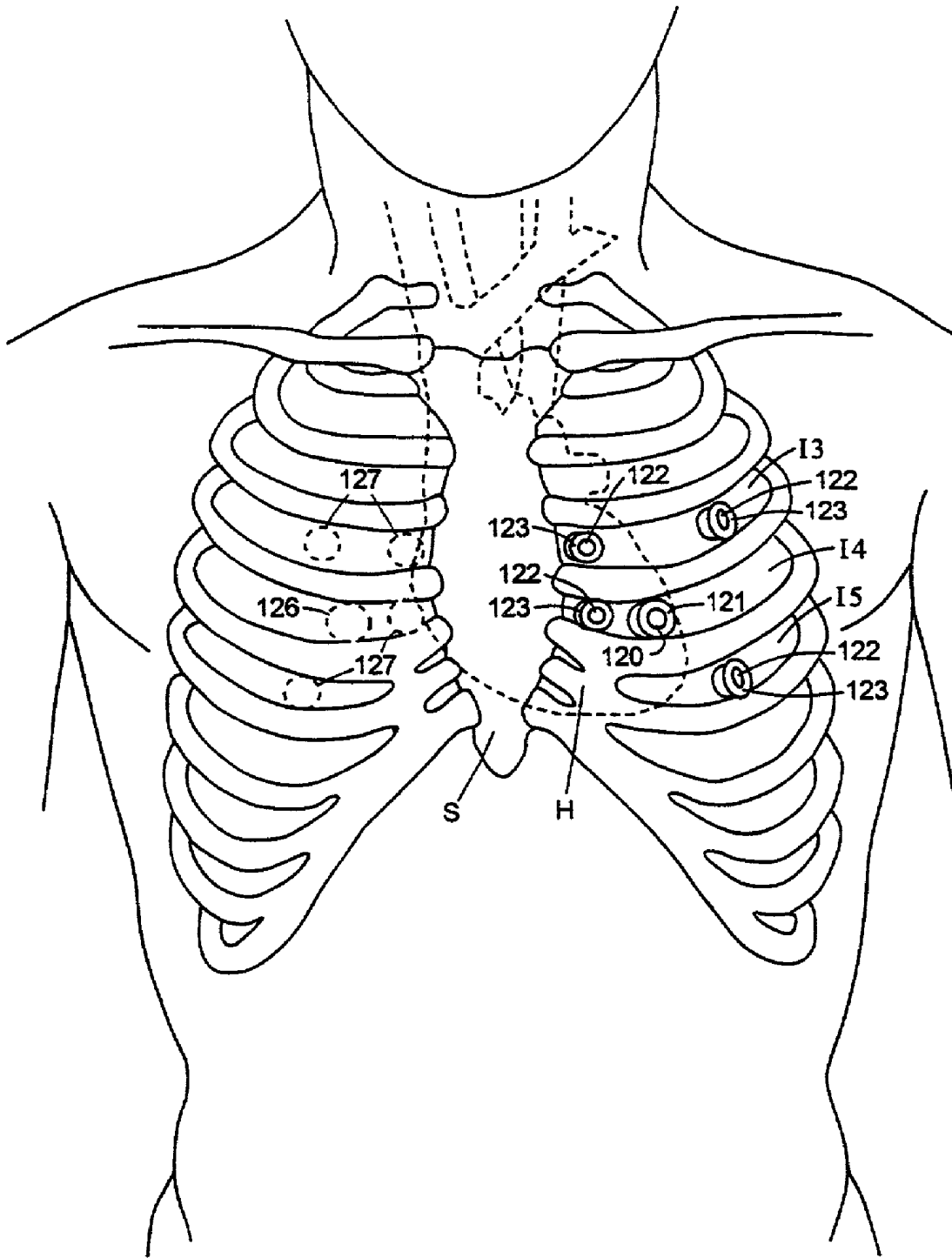

FIG. 5

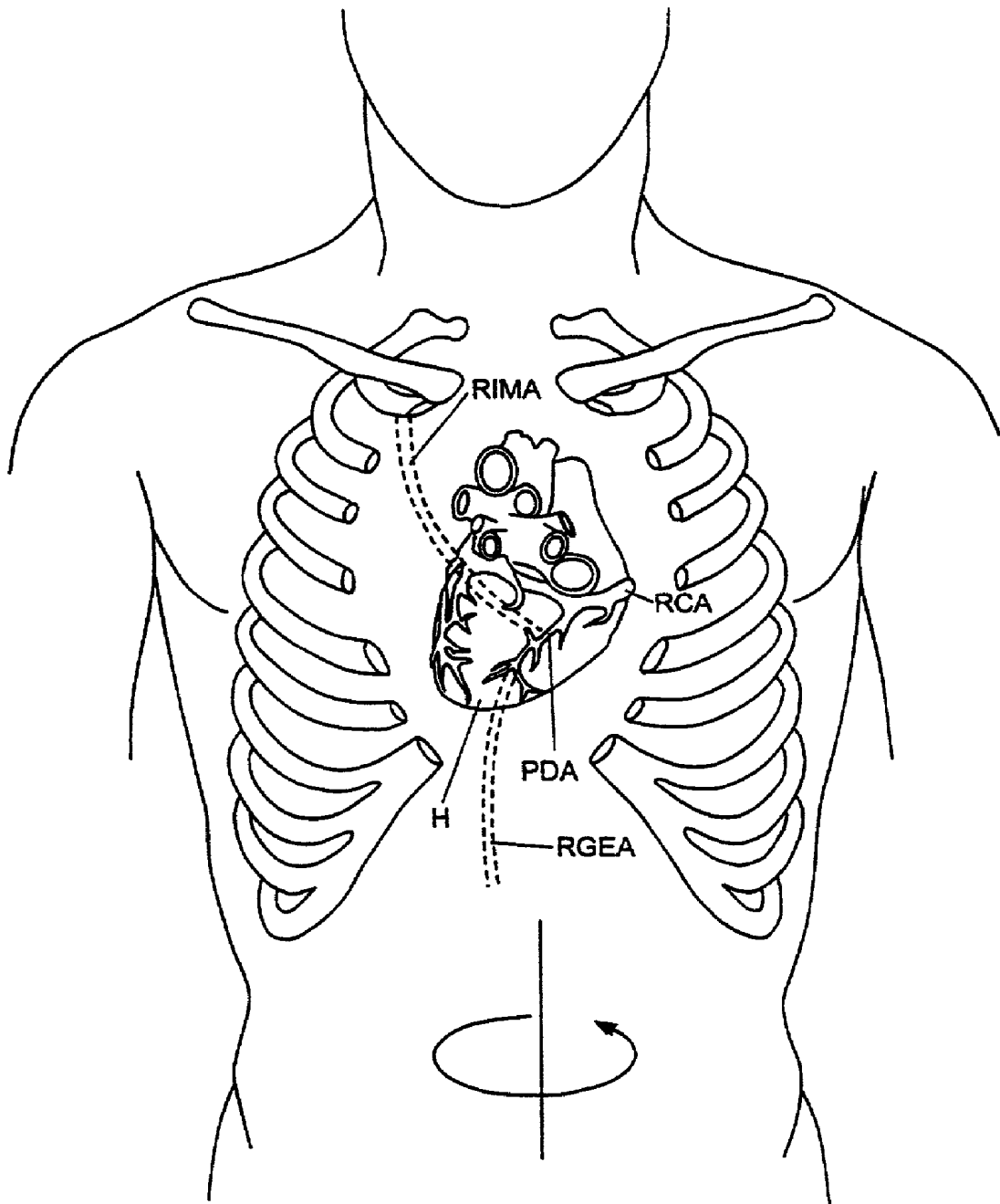

FIG.6

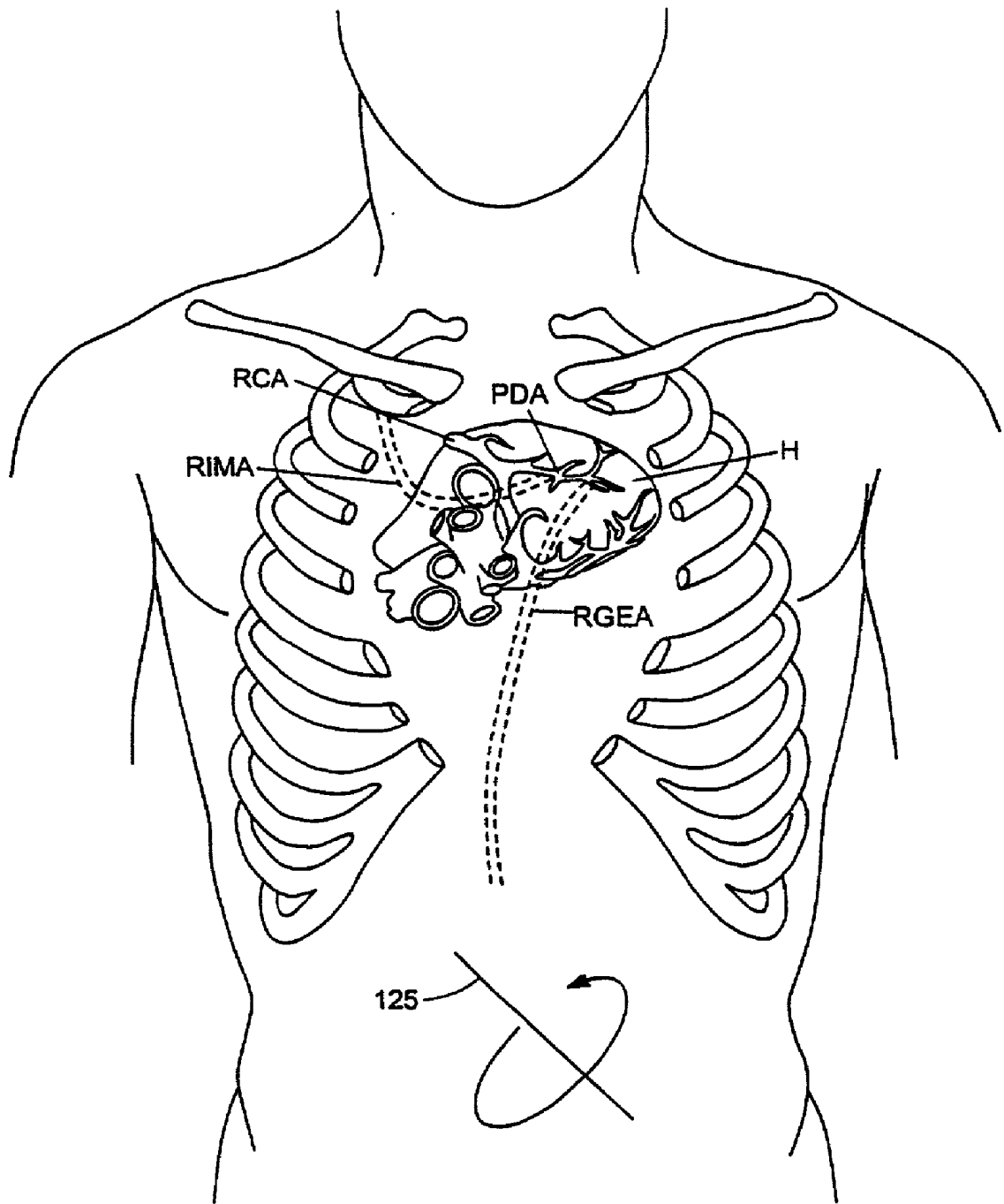

FIG. 7

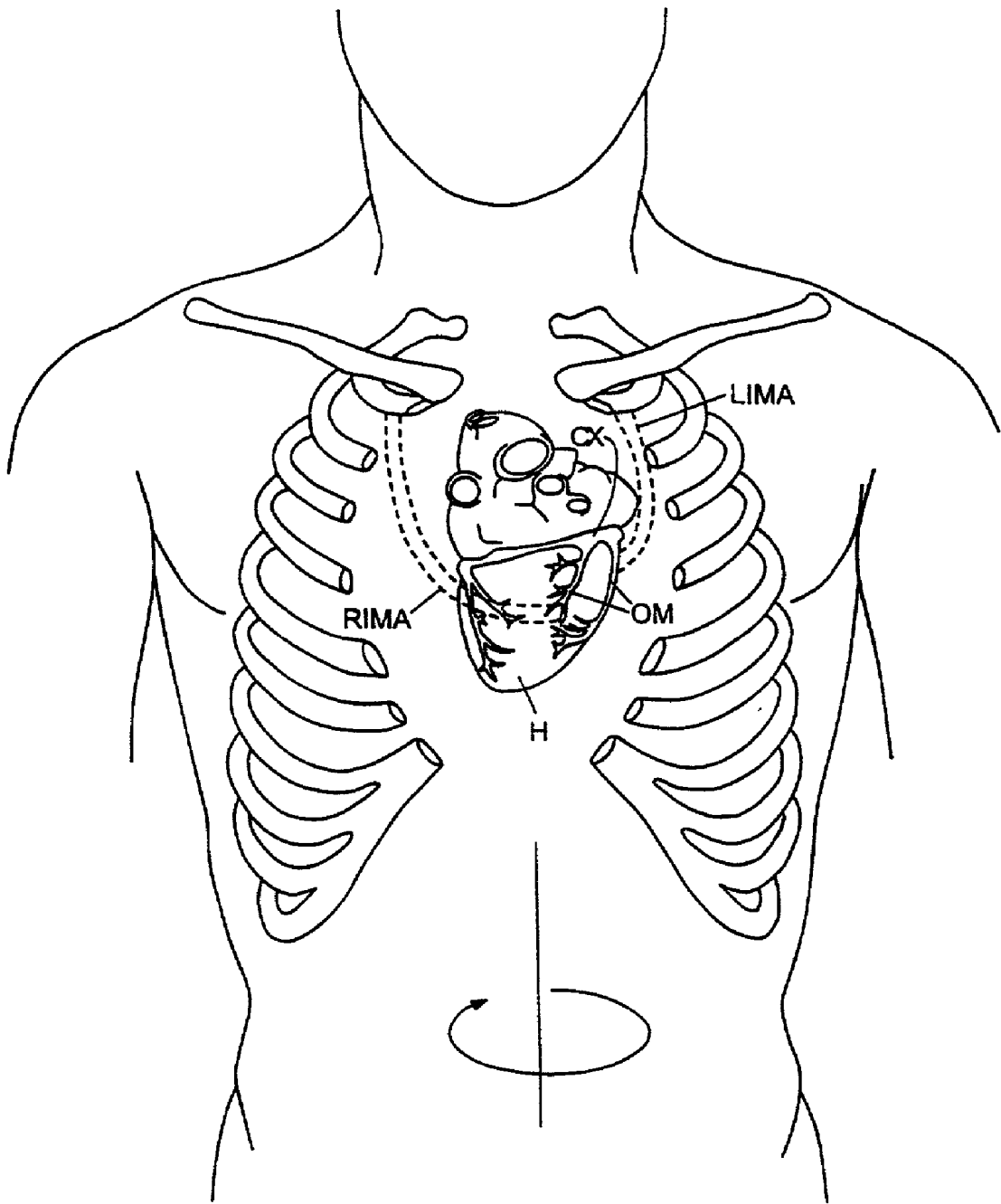

FIG.8

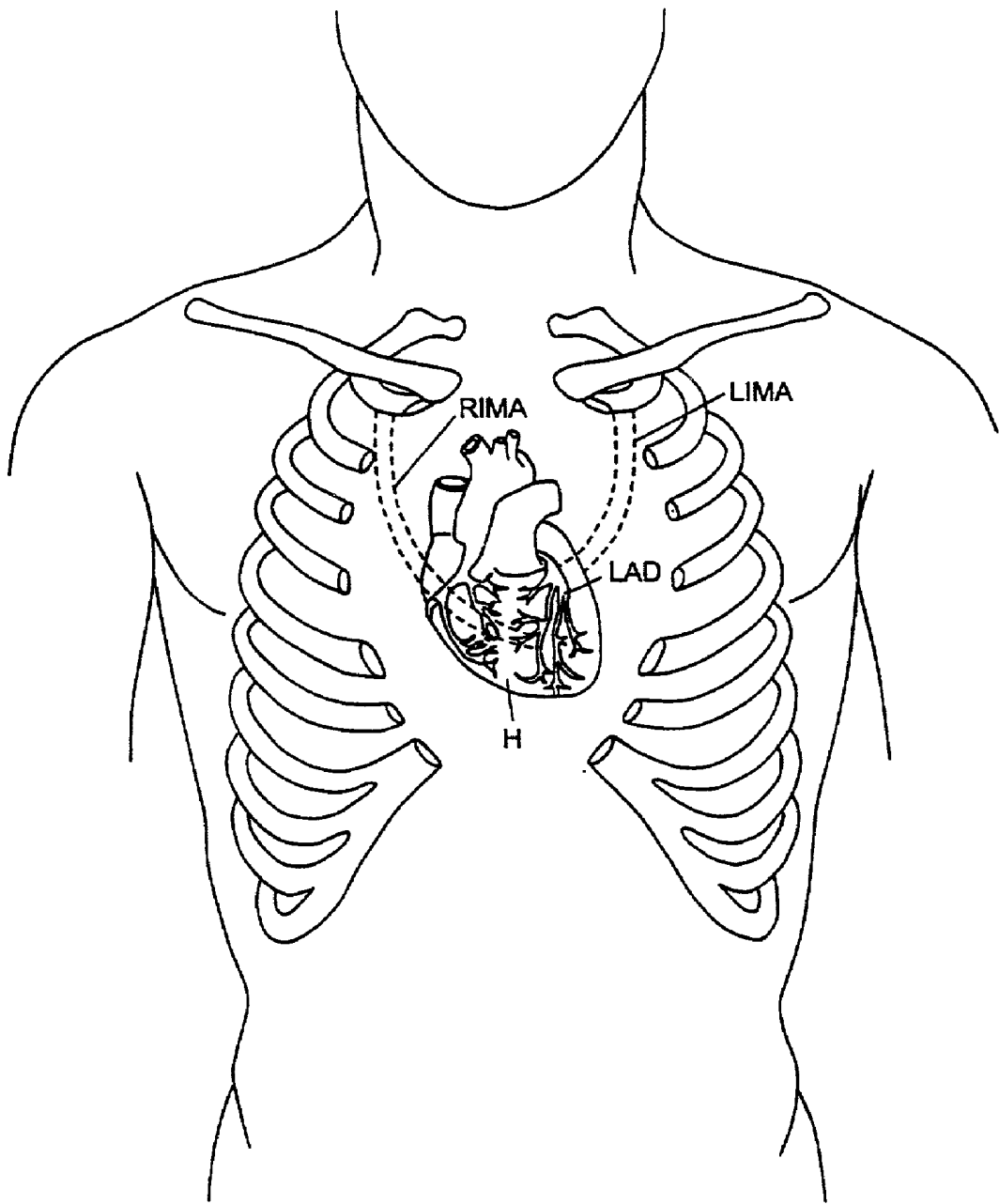

FIG.9

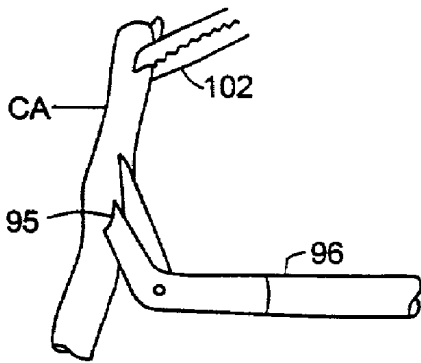

FIG. 10

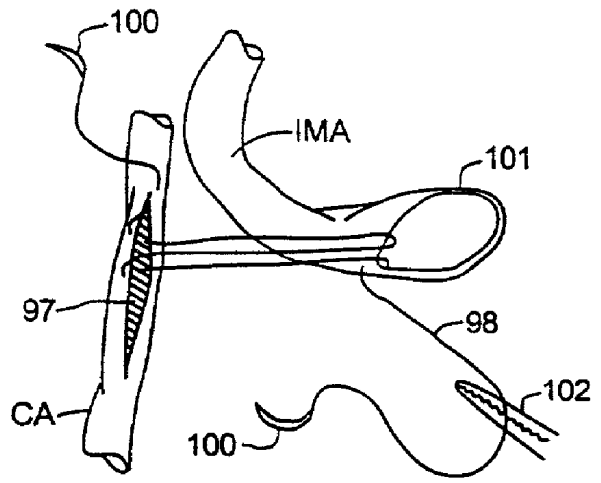

FIG. 11

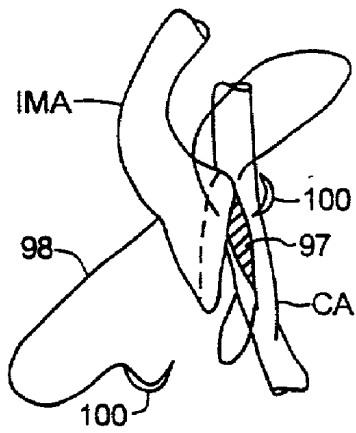

FIG. 12

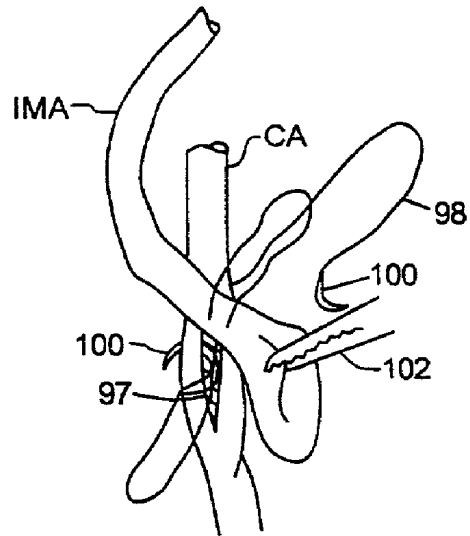

FIG. 13

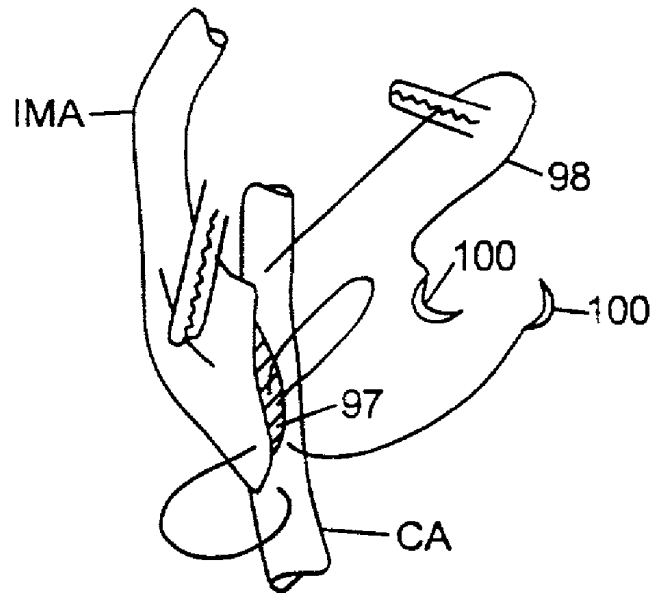

FIG. 14

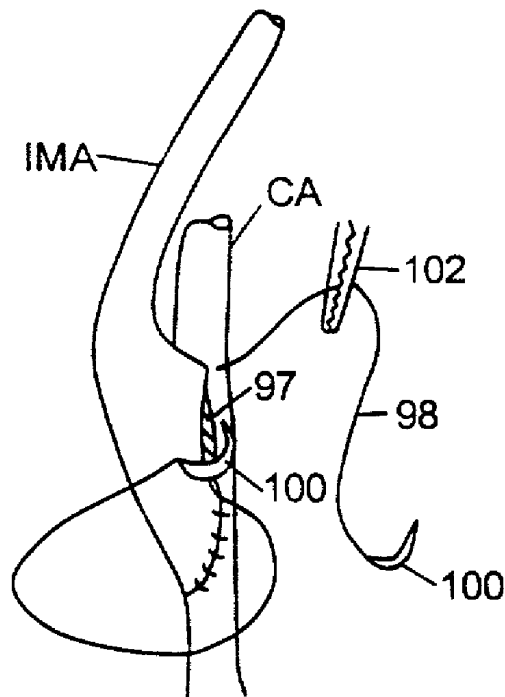

FIG. 15

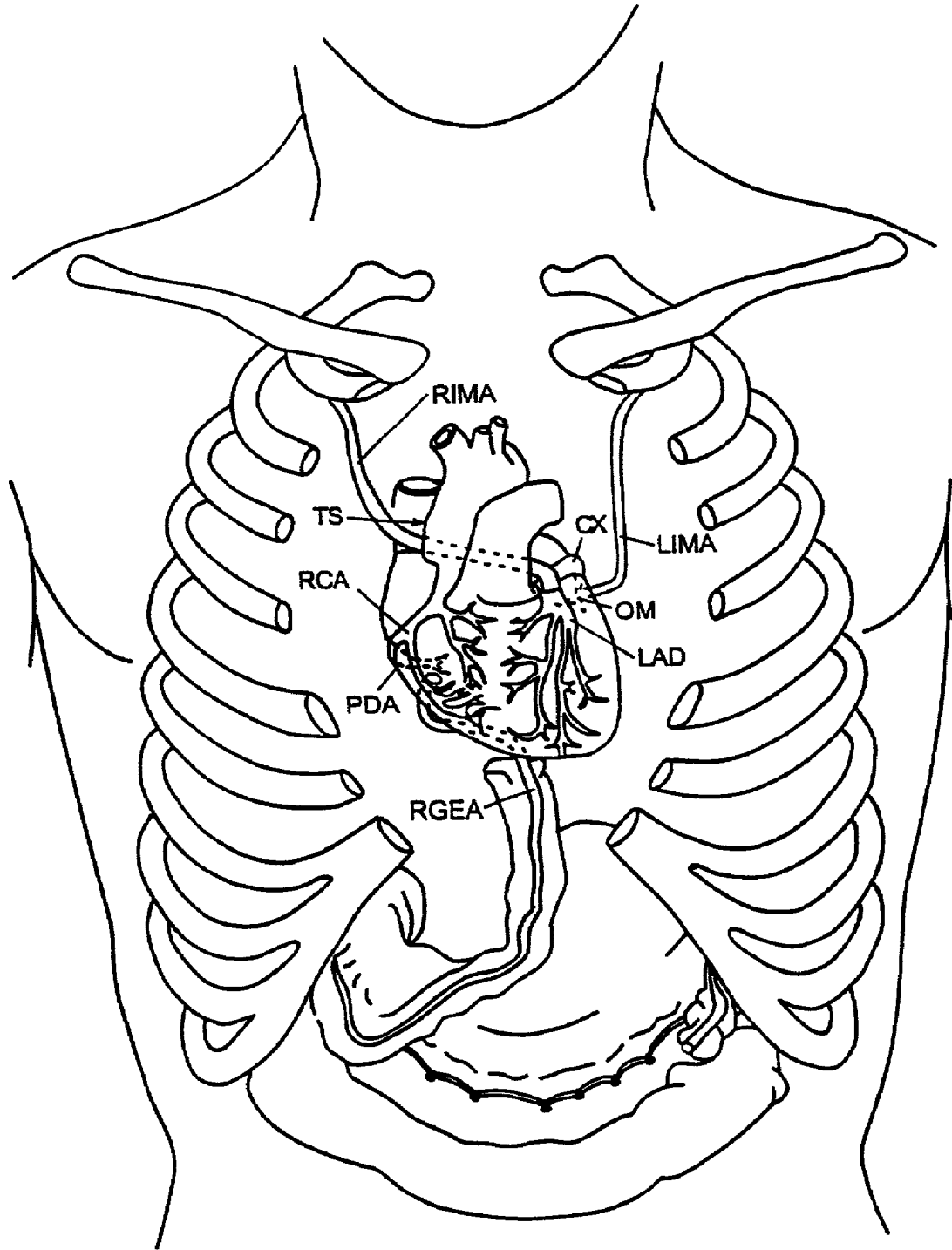

FIG.16

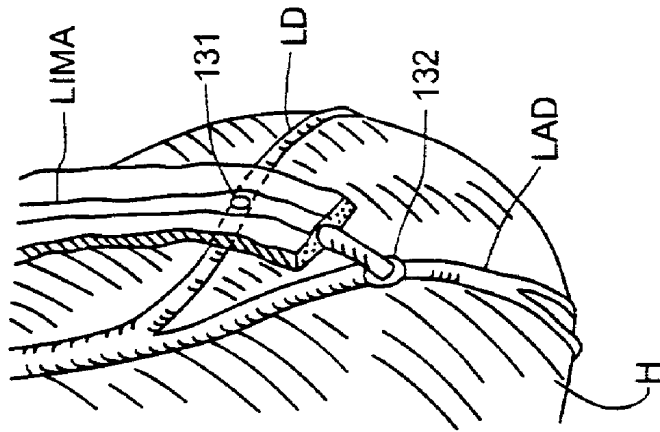

FIG. 19

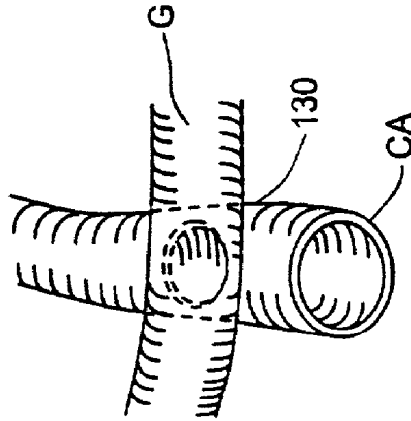

FIG. 18

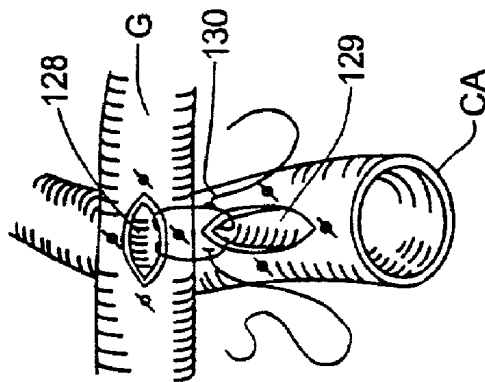

FIG. 17

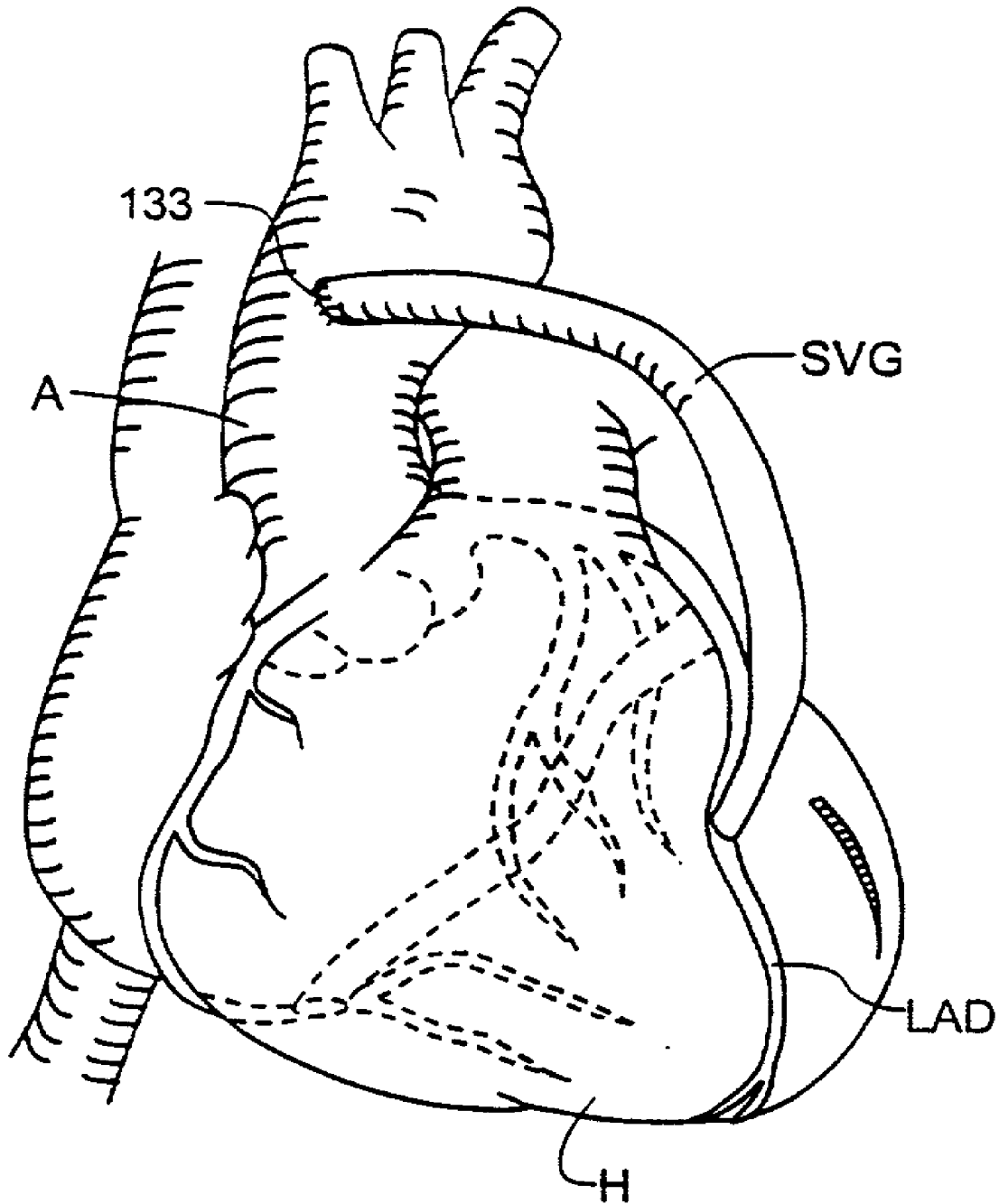

FIG.20

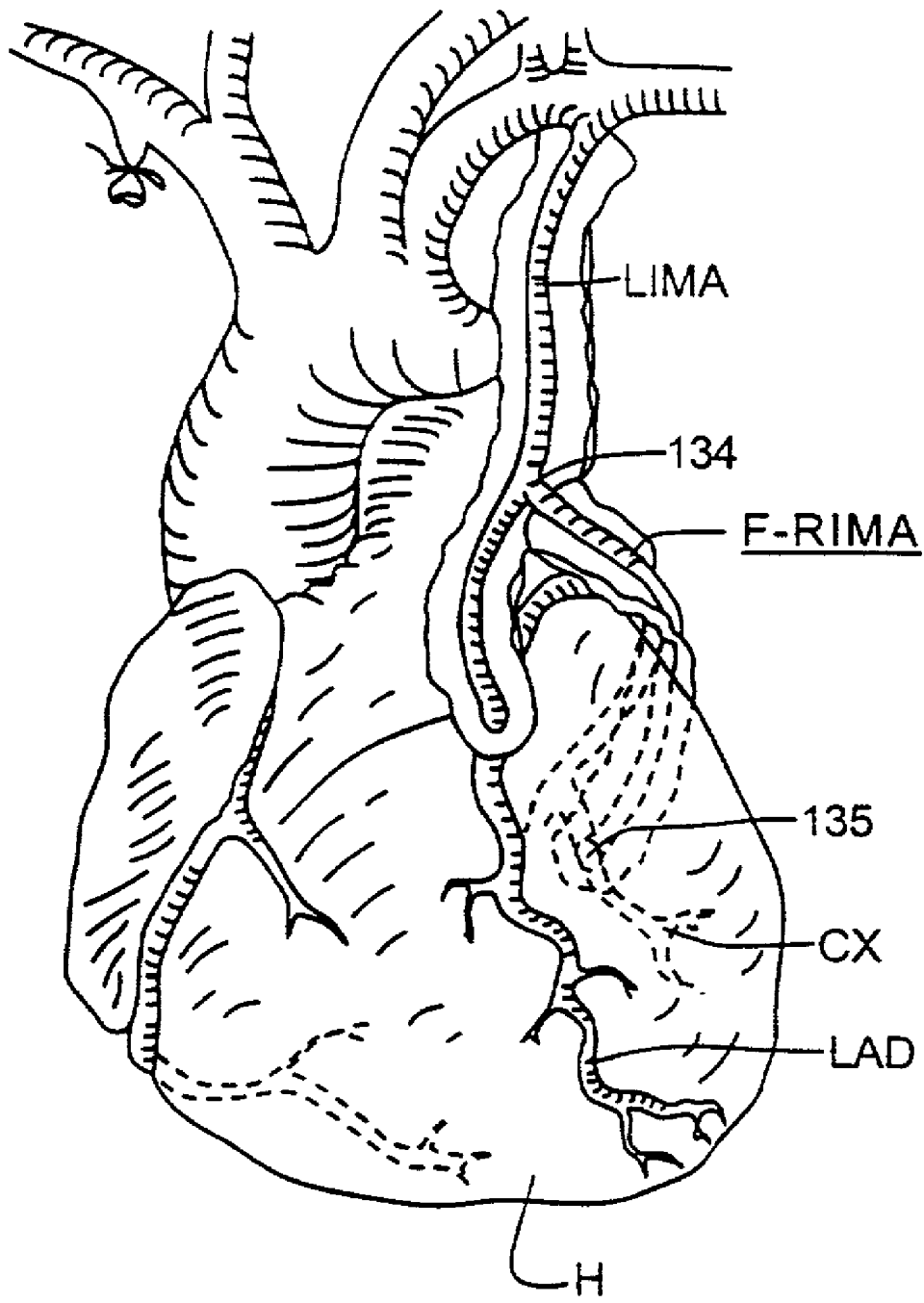

FIG.21

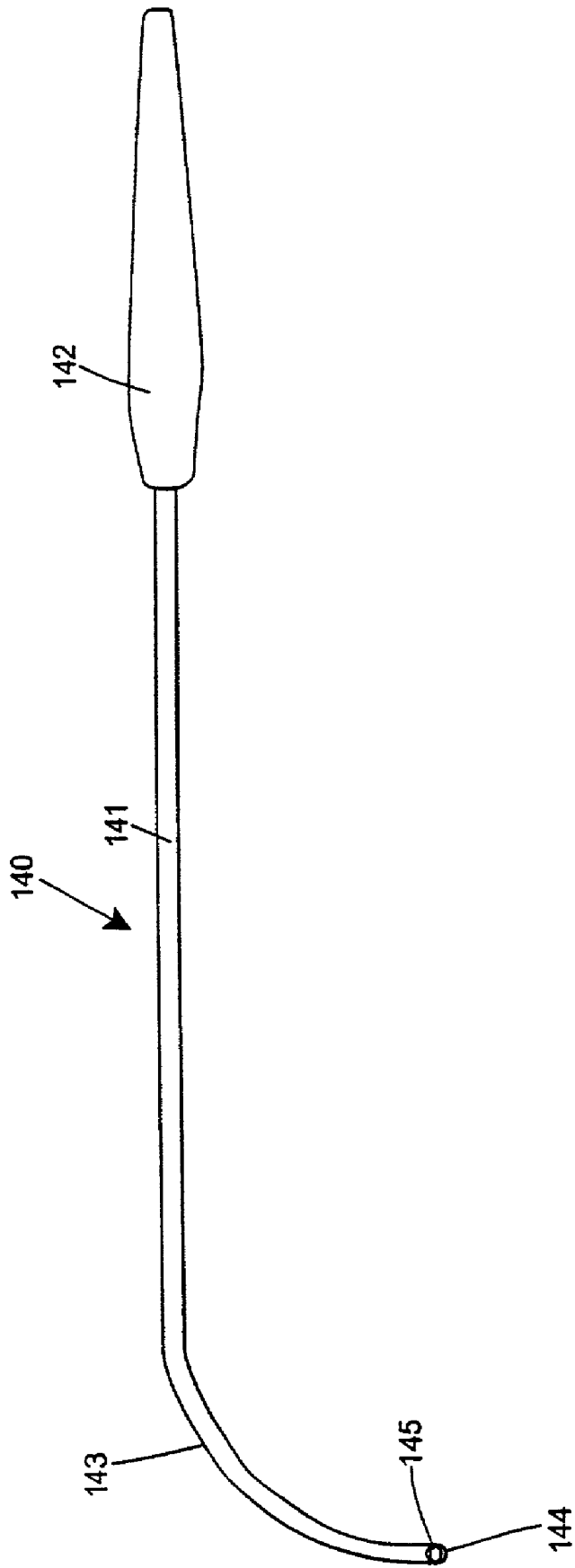

FIG. 22

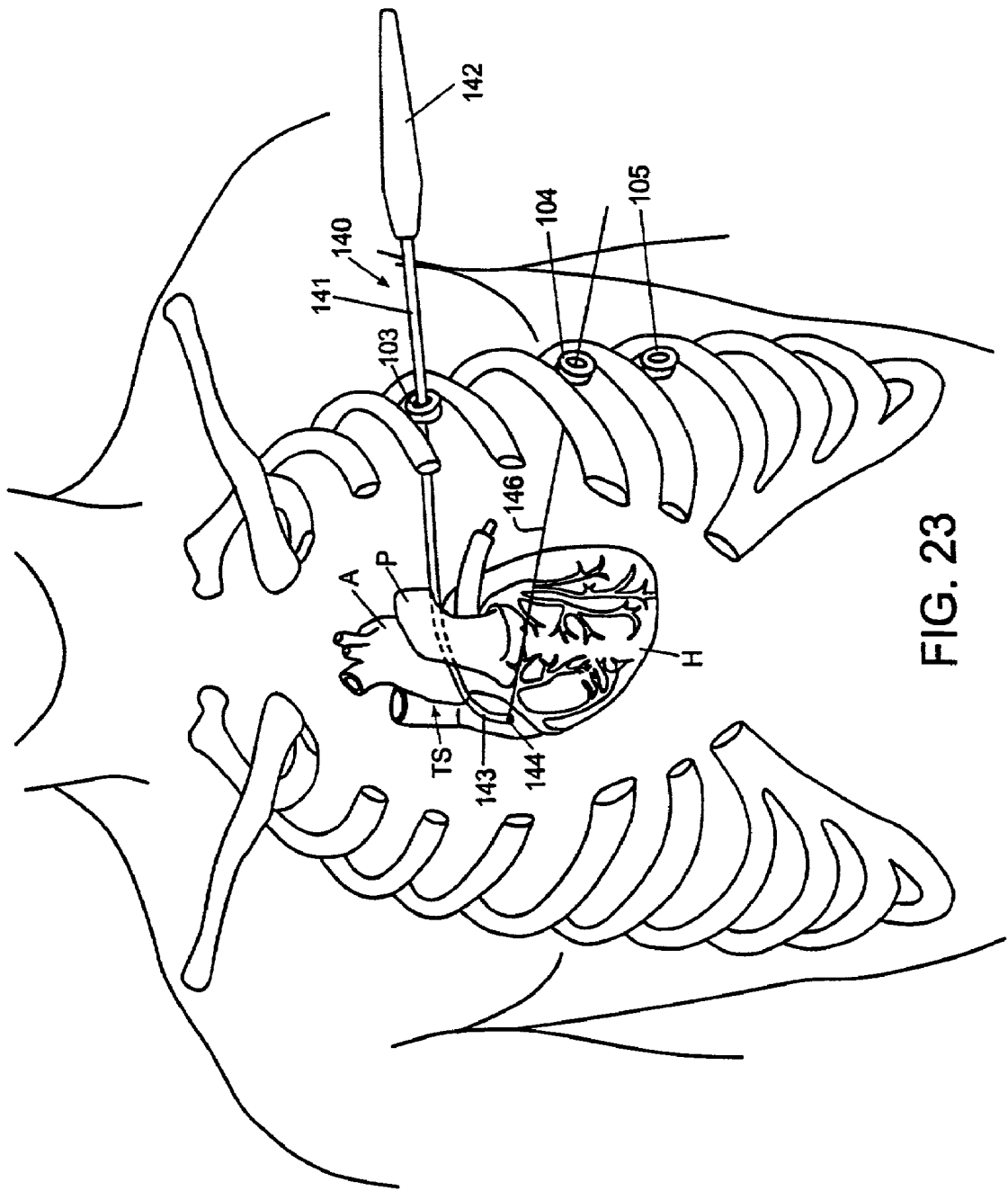

FIG. 23

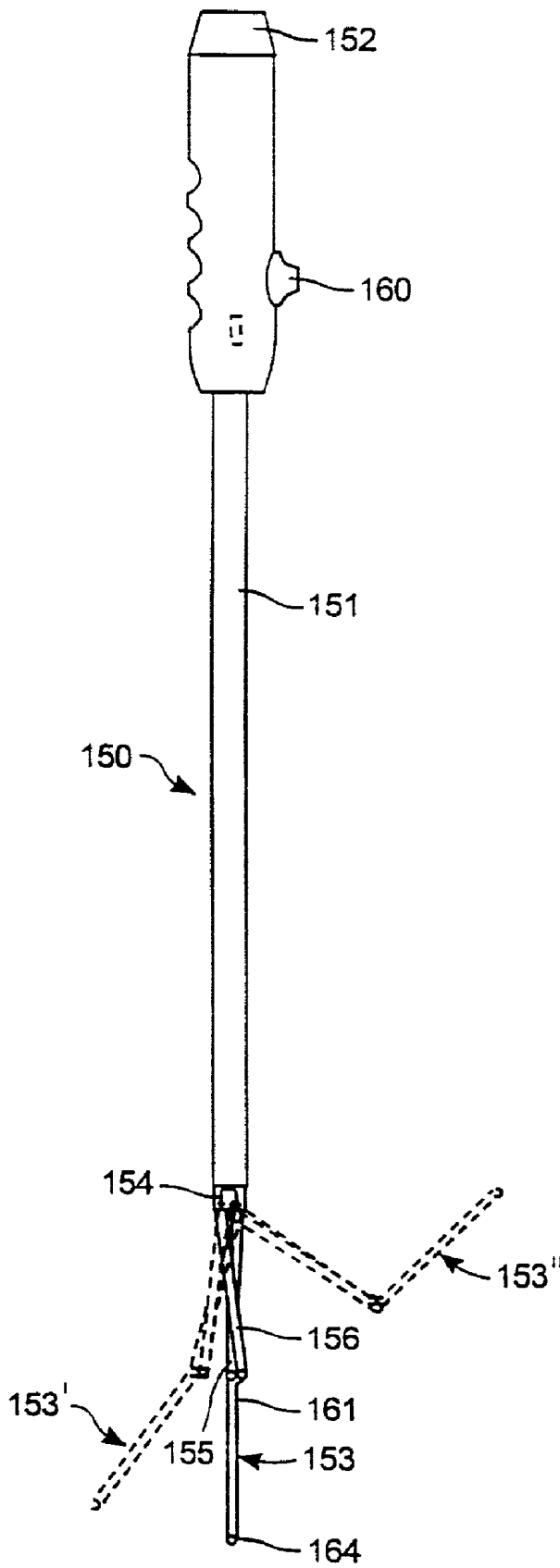

FIG. 24

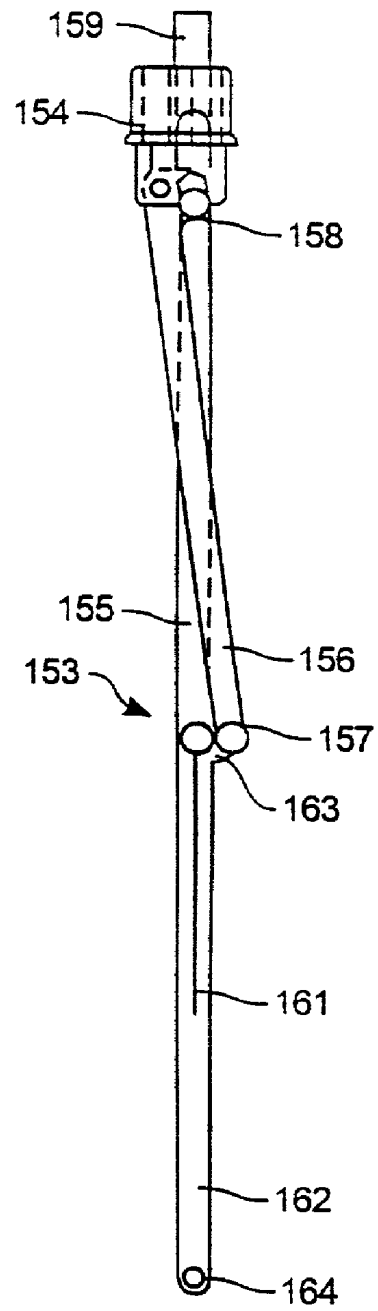

FIG. 25

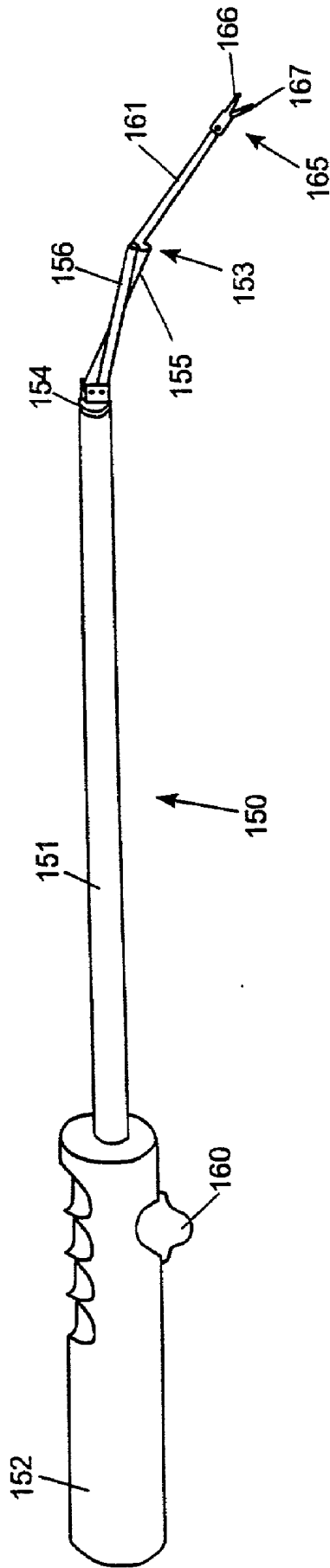
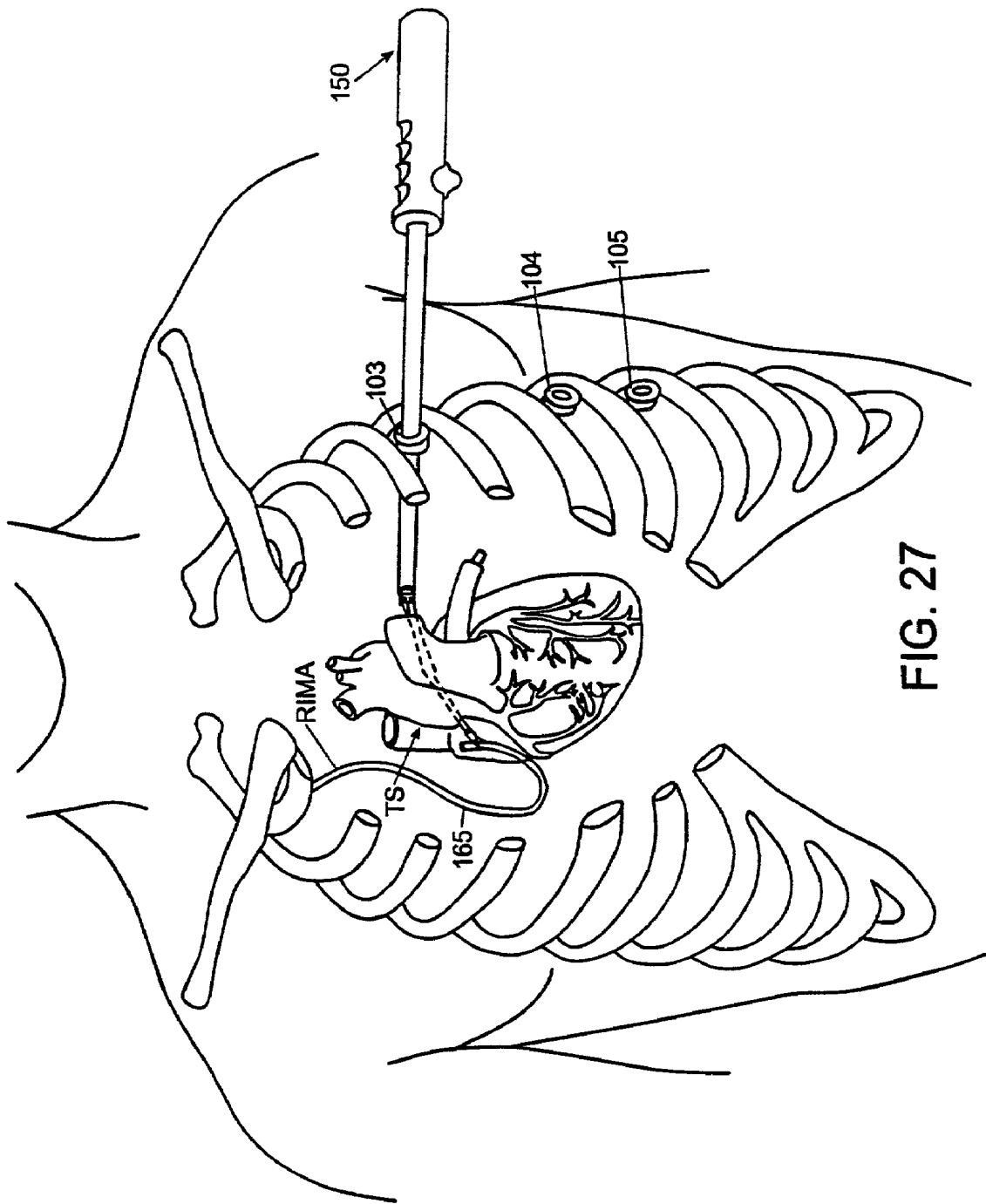

FIG. 26



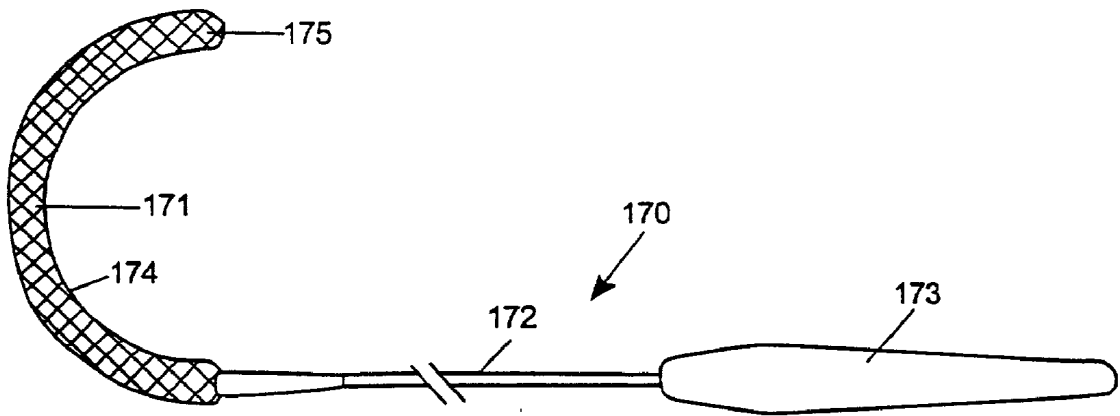

FIG. 28

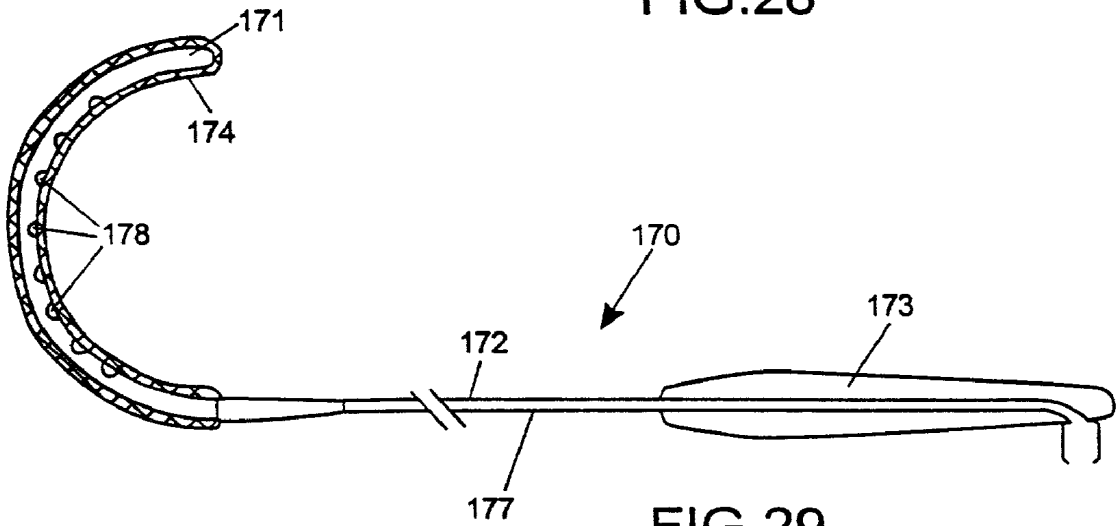

FIG. 29

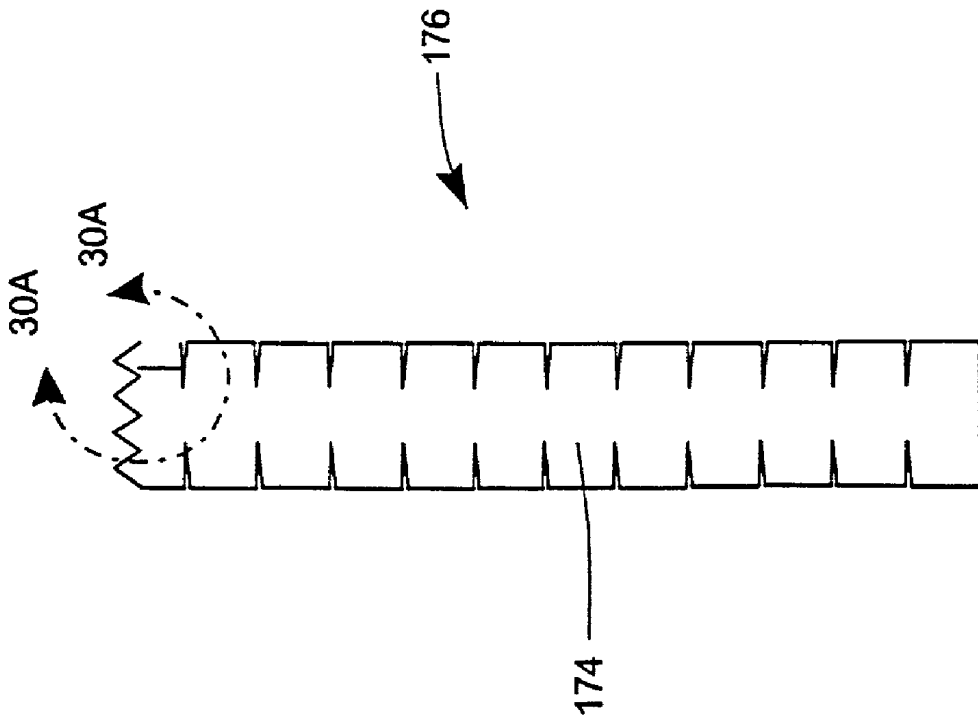

FIG. 30A

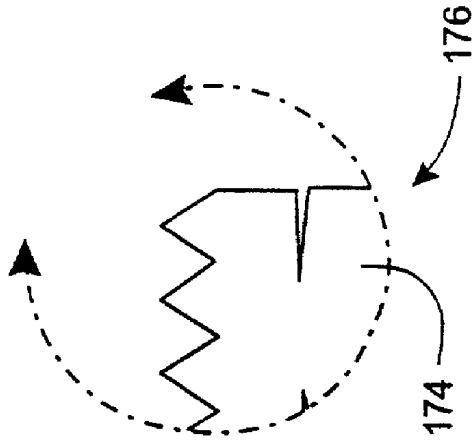

FIG. 30B

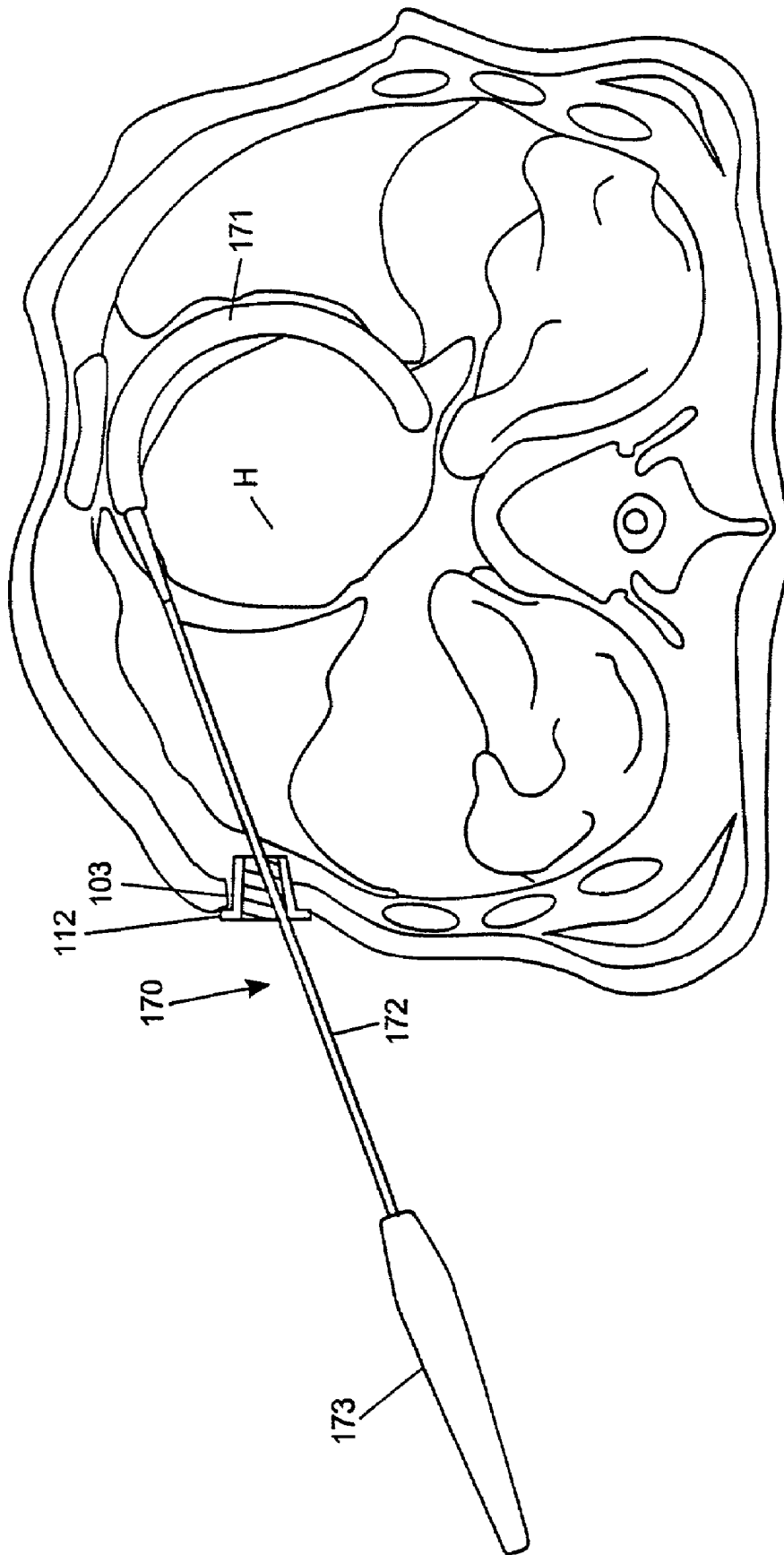
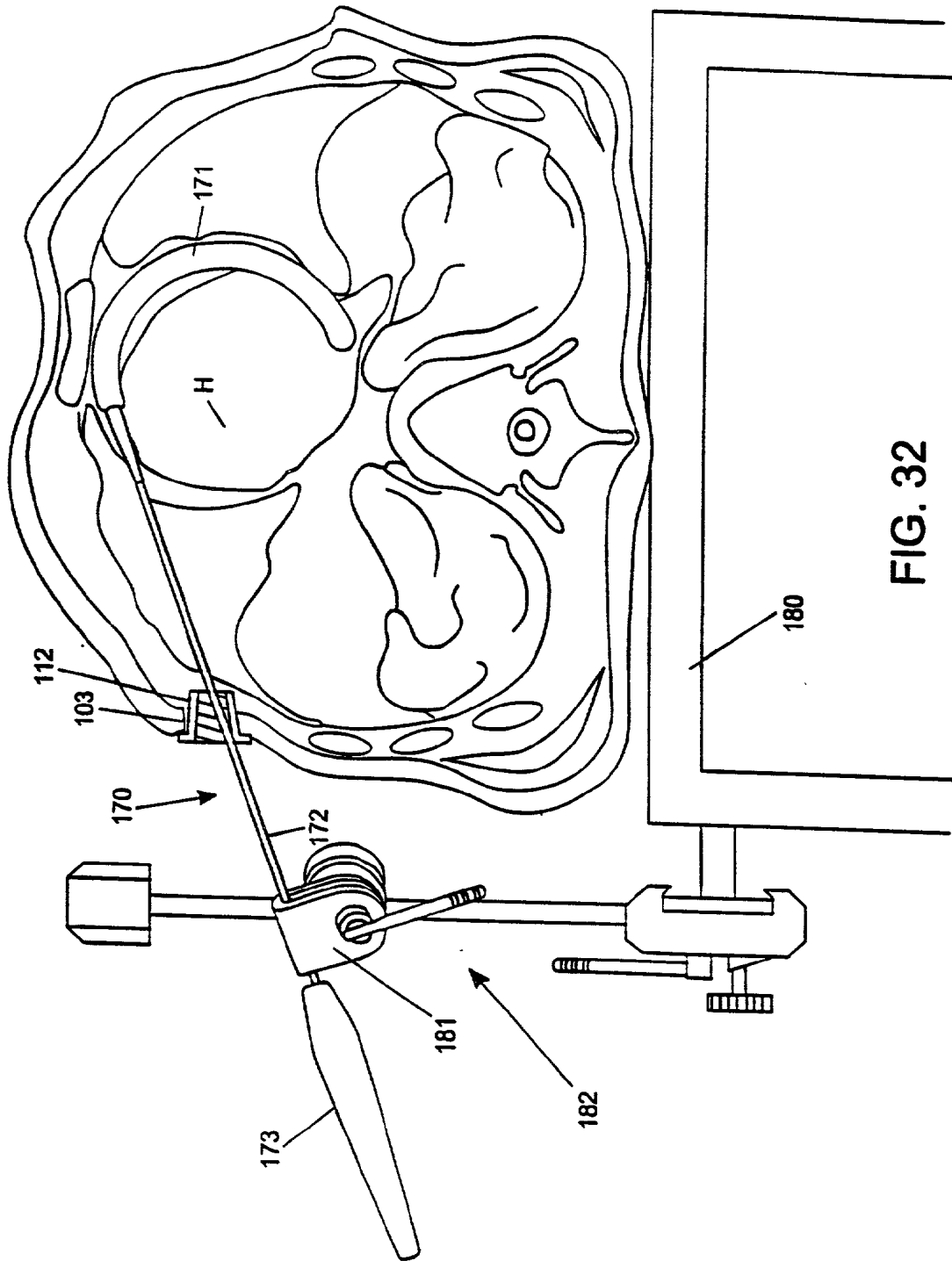

FIG. 31



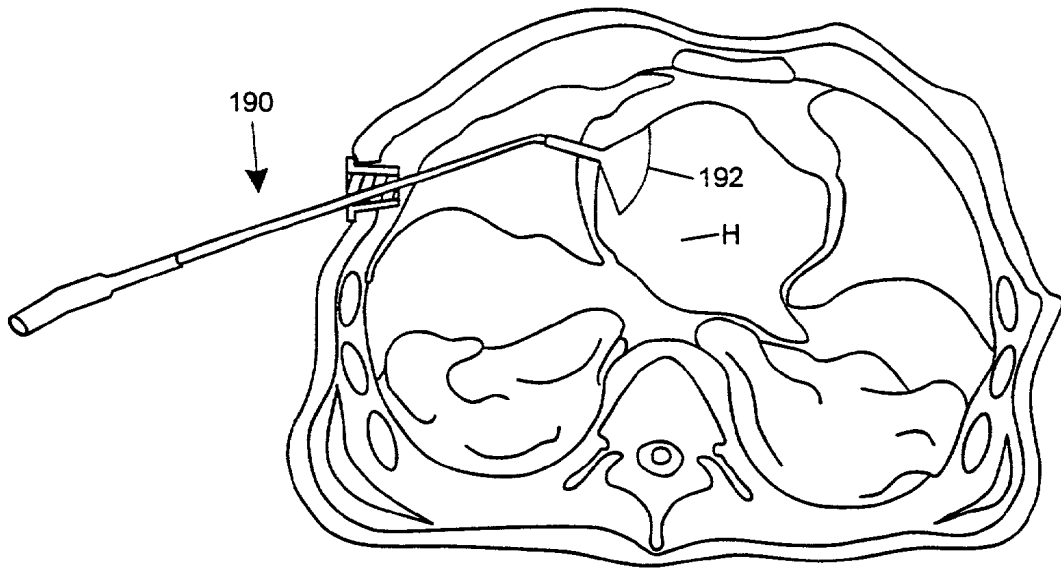

FIG. 34

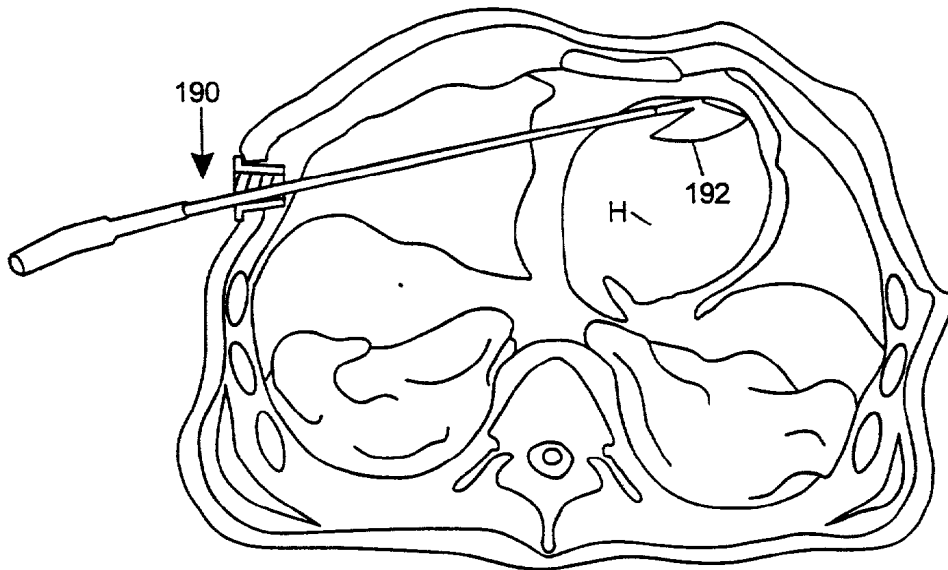
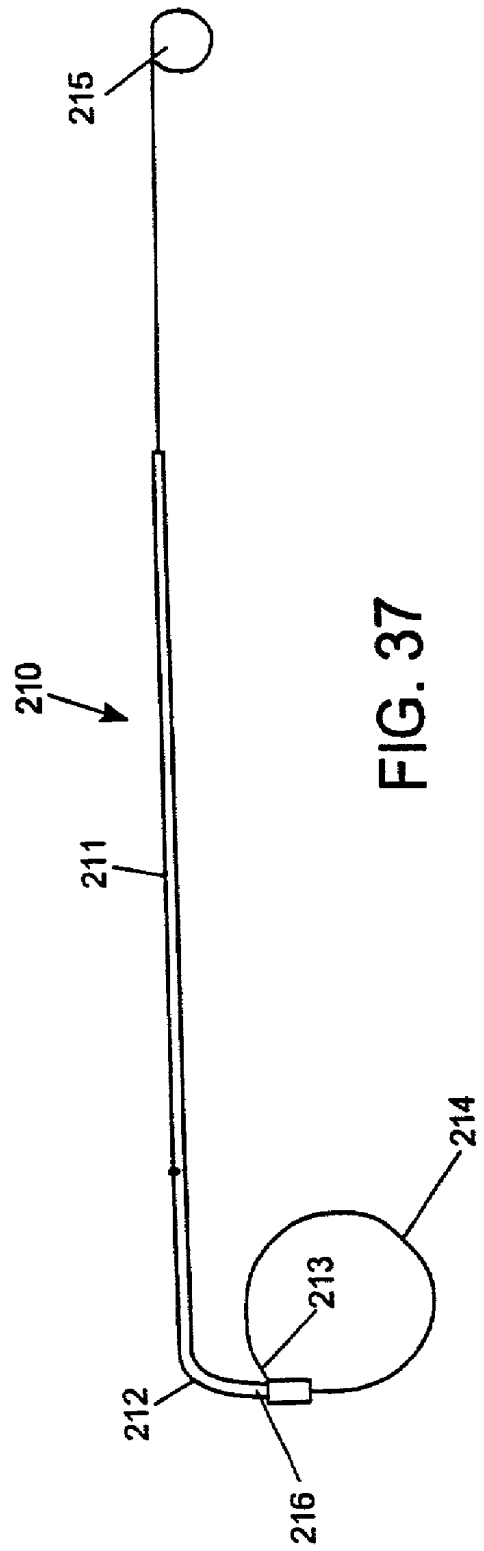
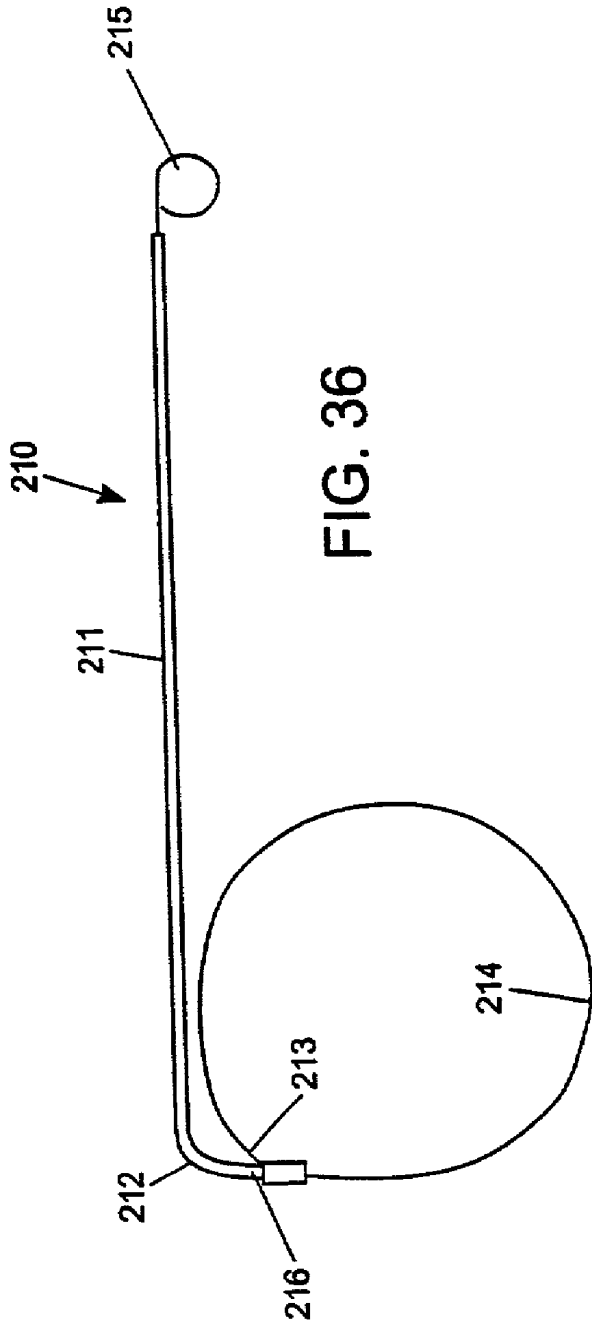

FIG. 35



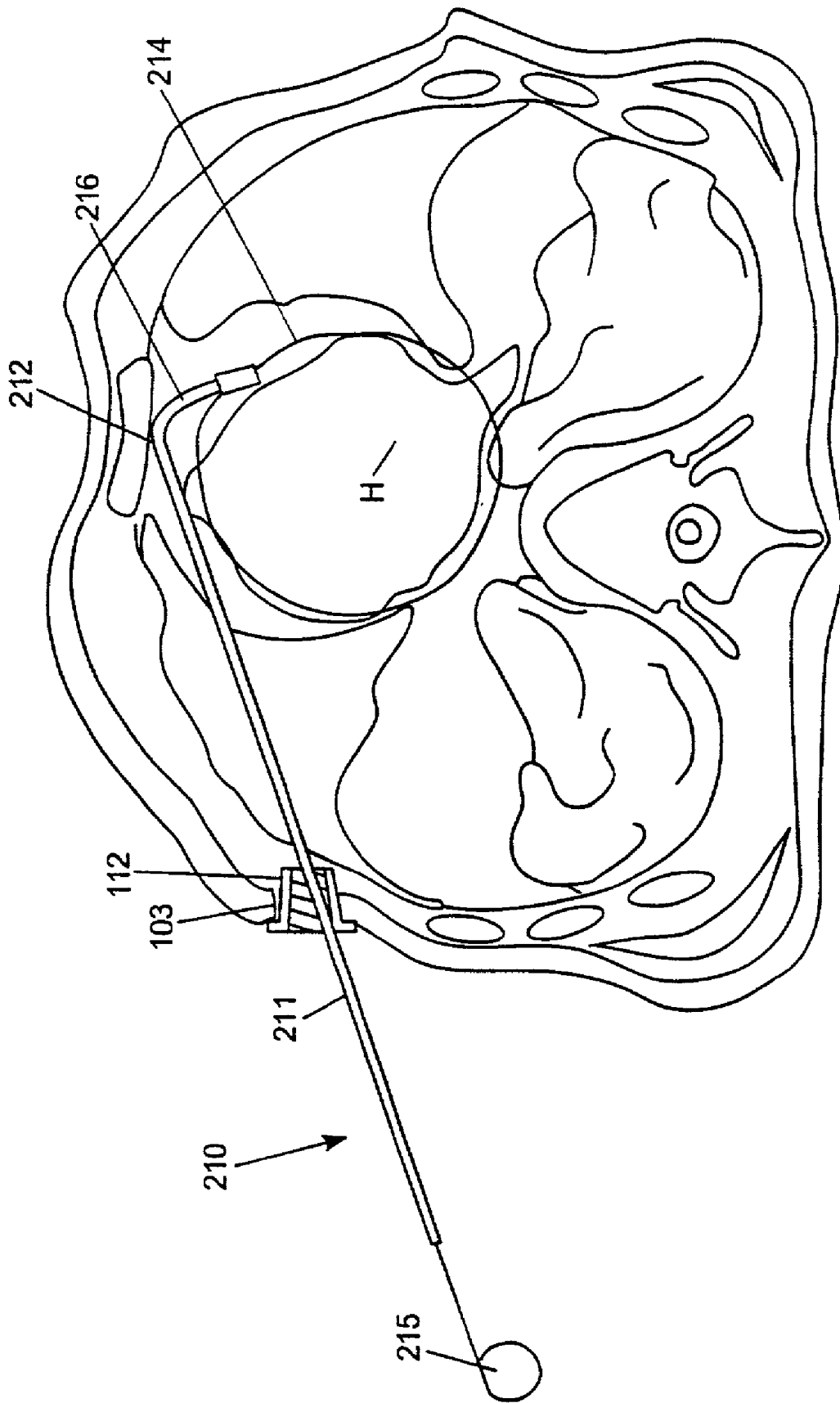
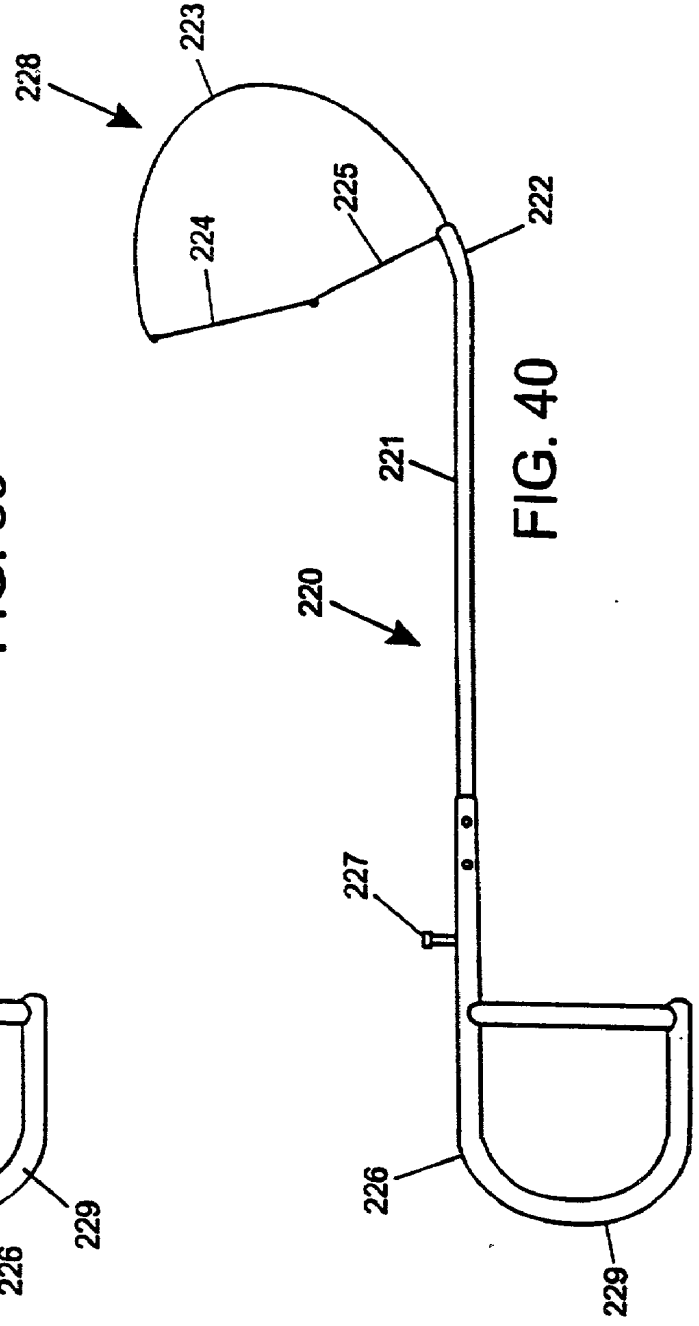
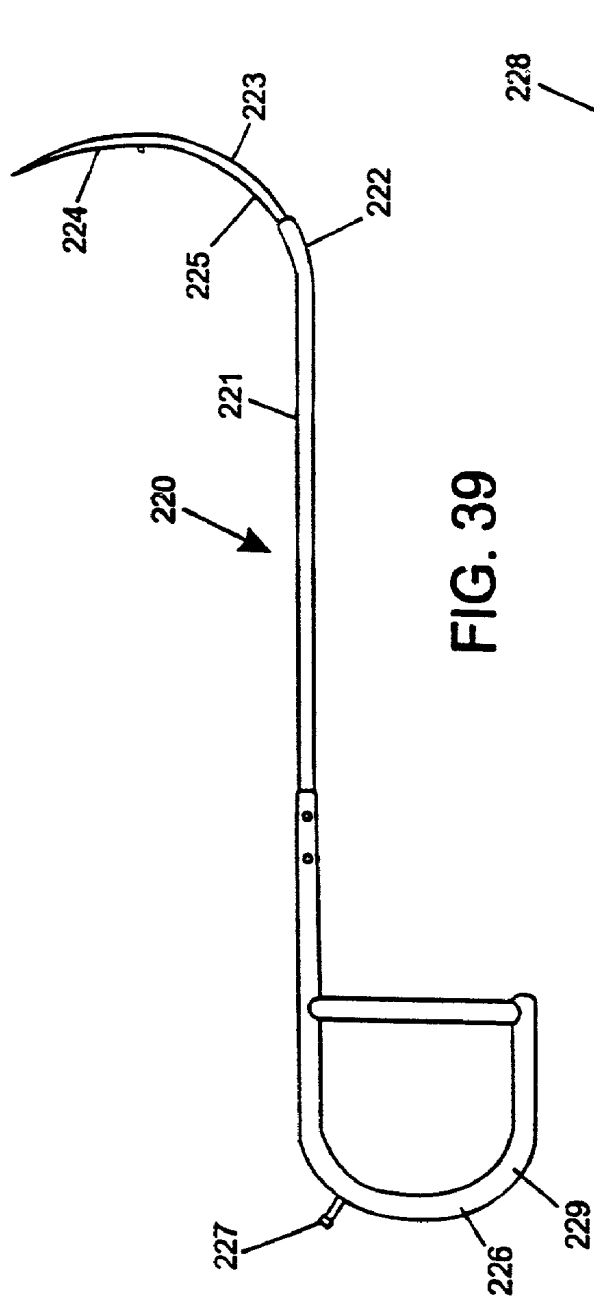

FIG. 38



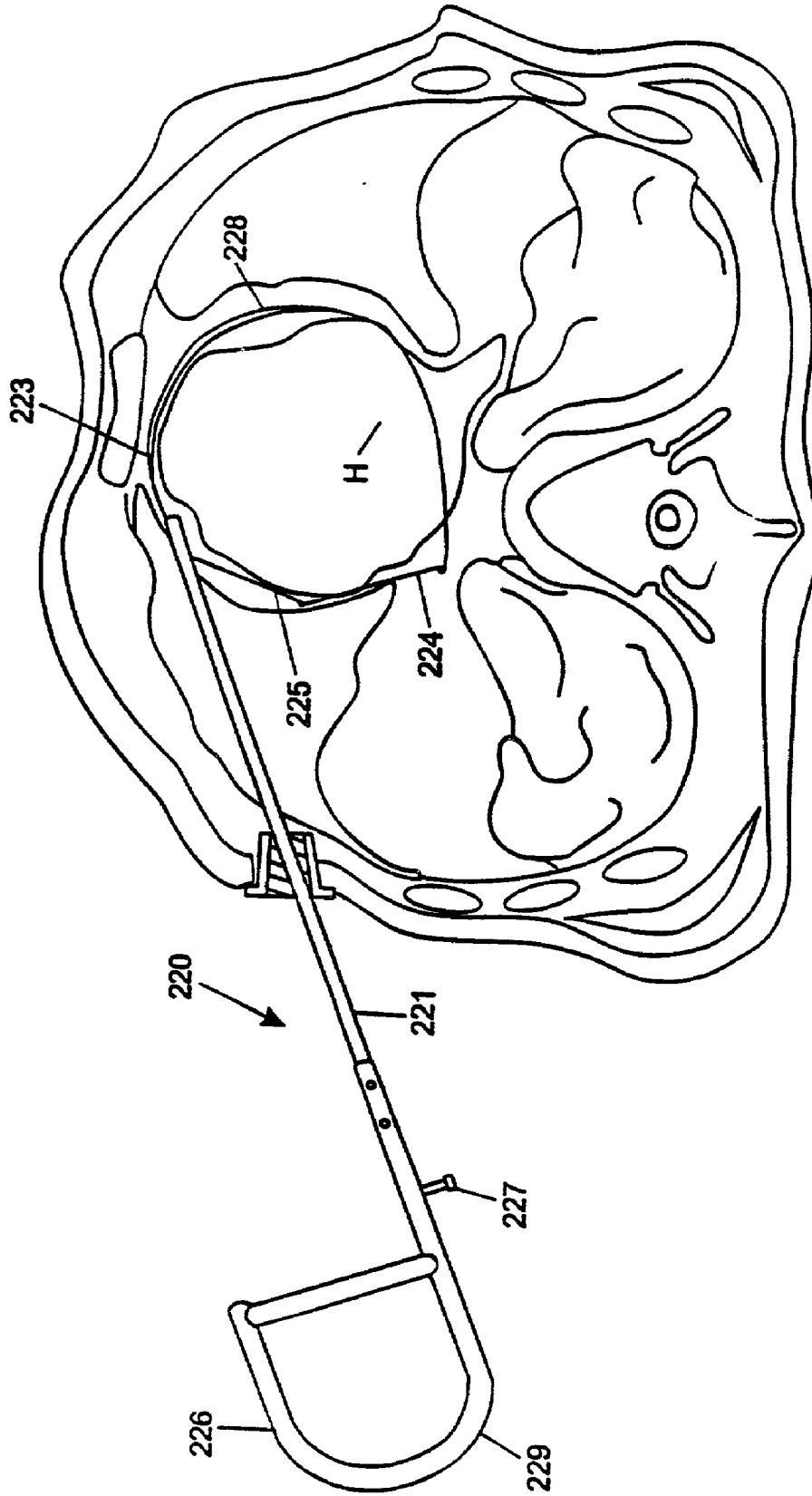

FIG. 41

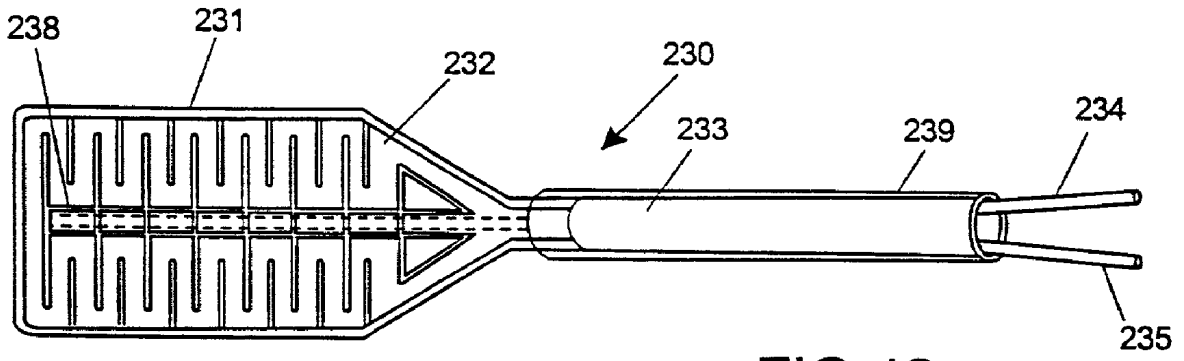

FIG. 42

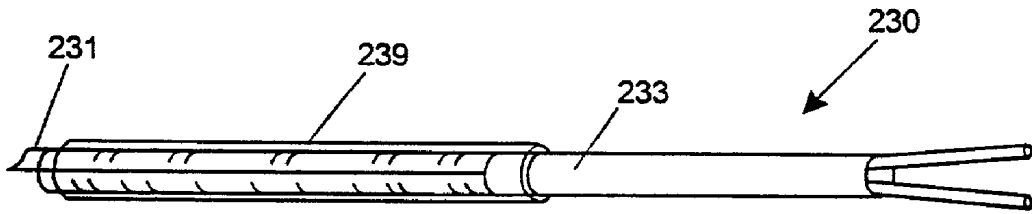

FIG. 43

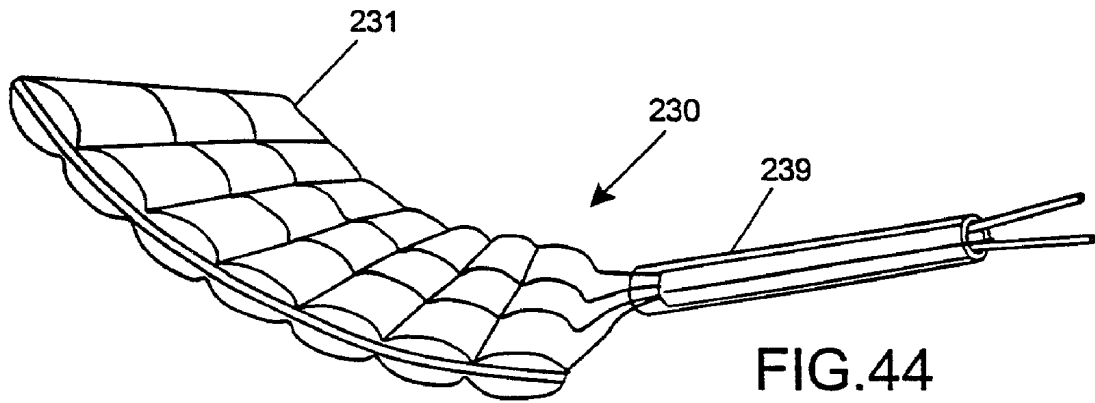

FIG. 44

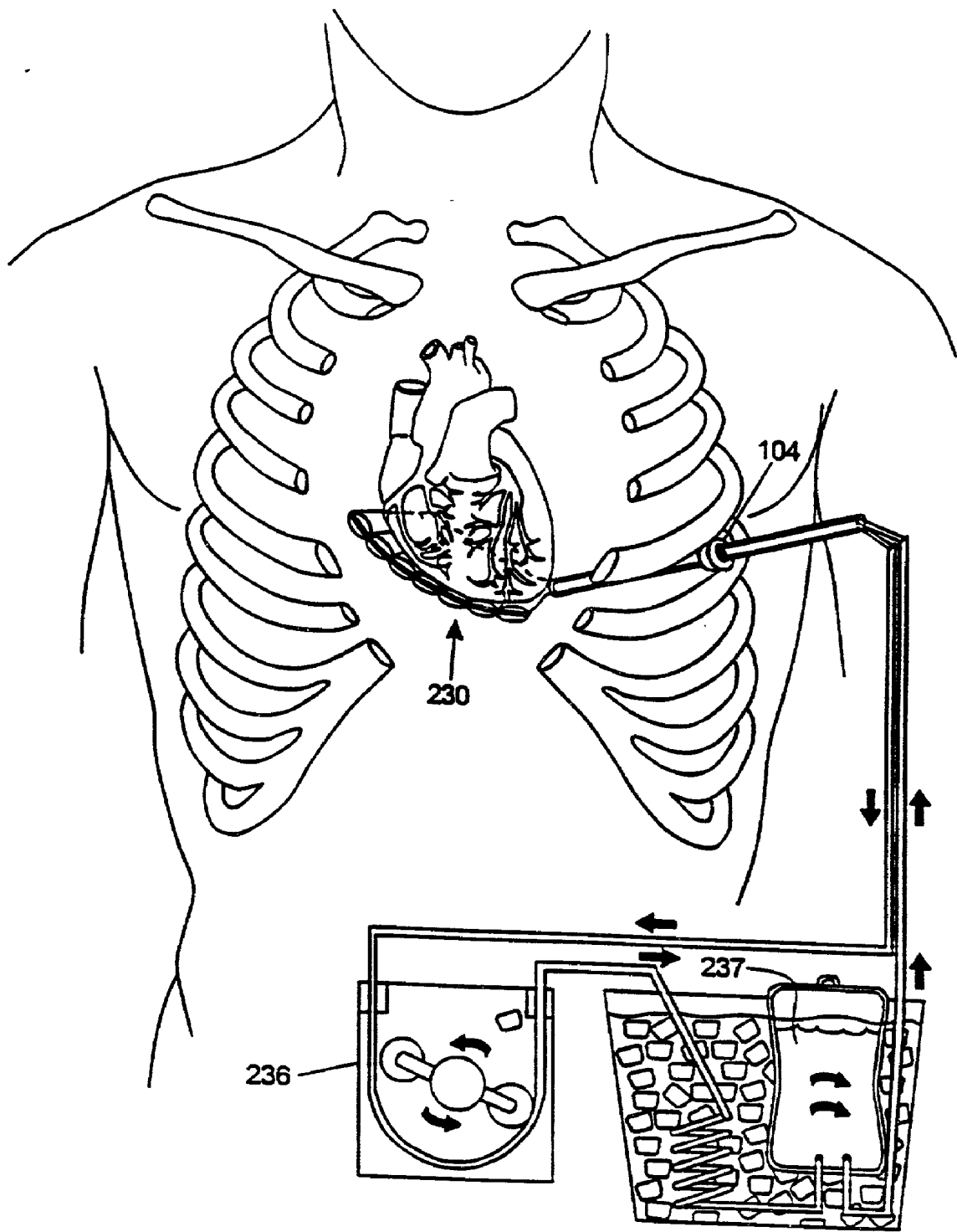

FIG.45

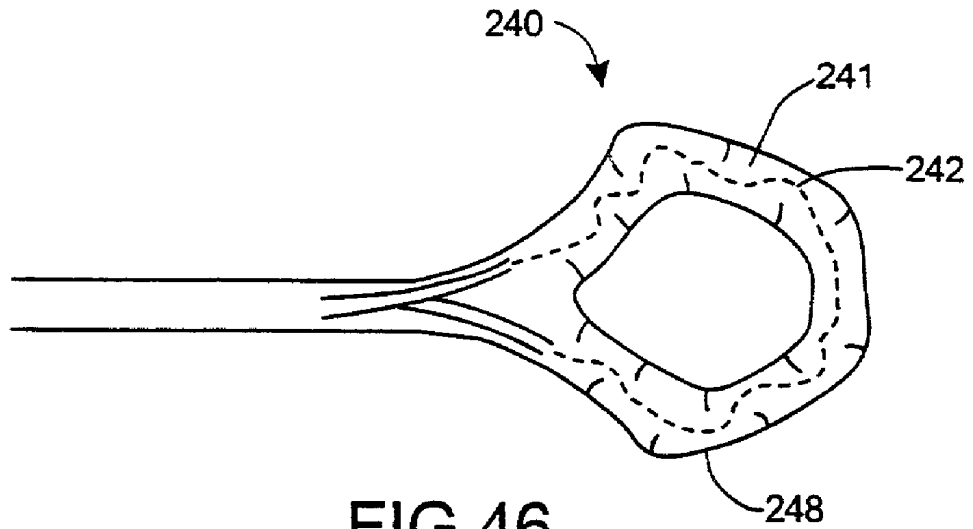

FIG. 46

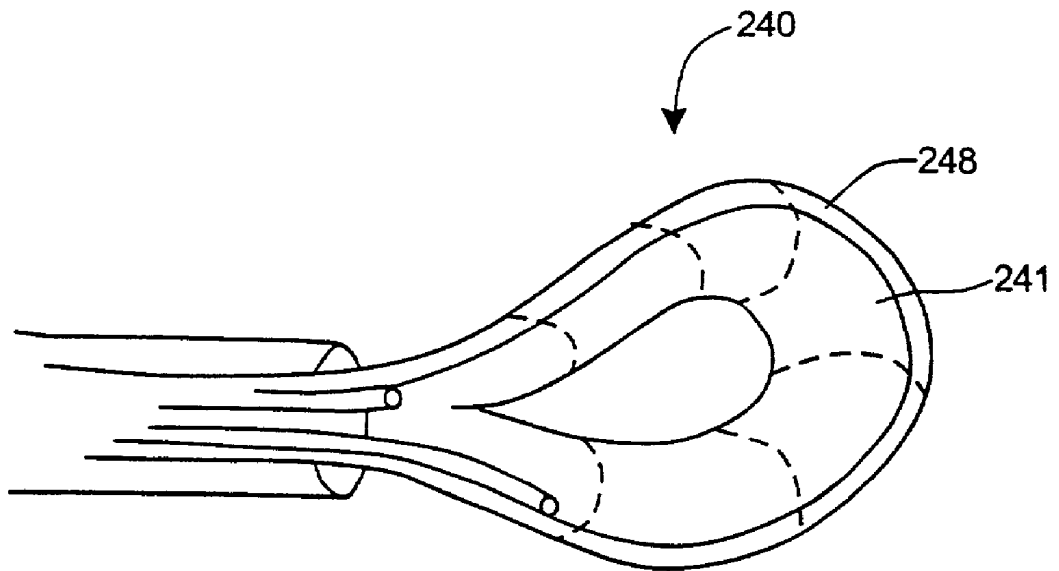

FIG. 47

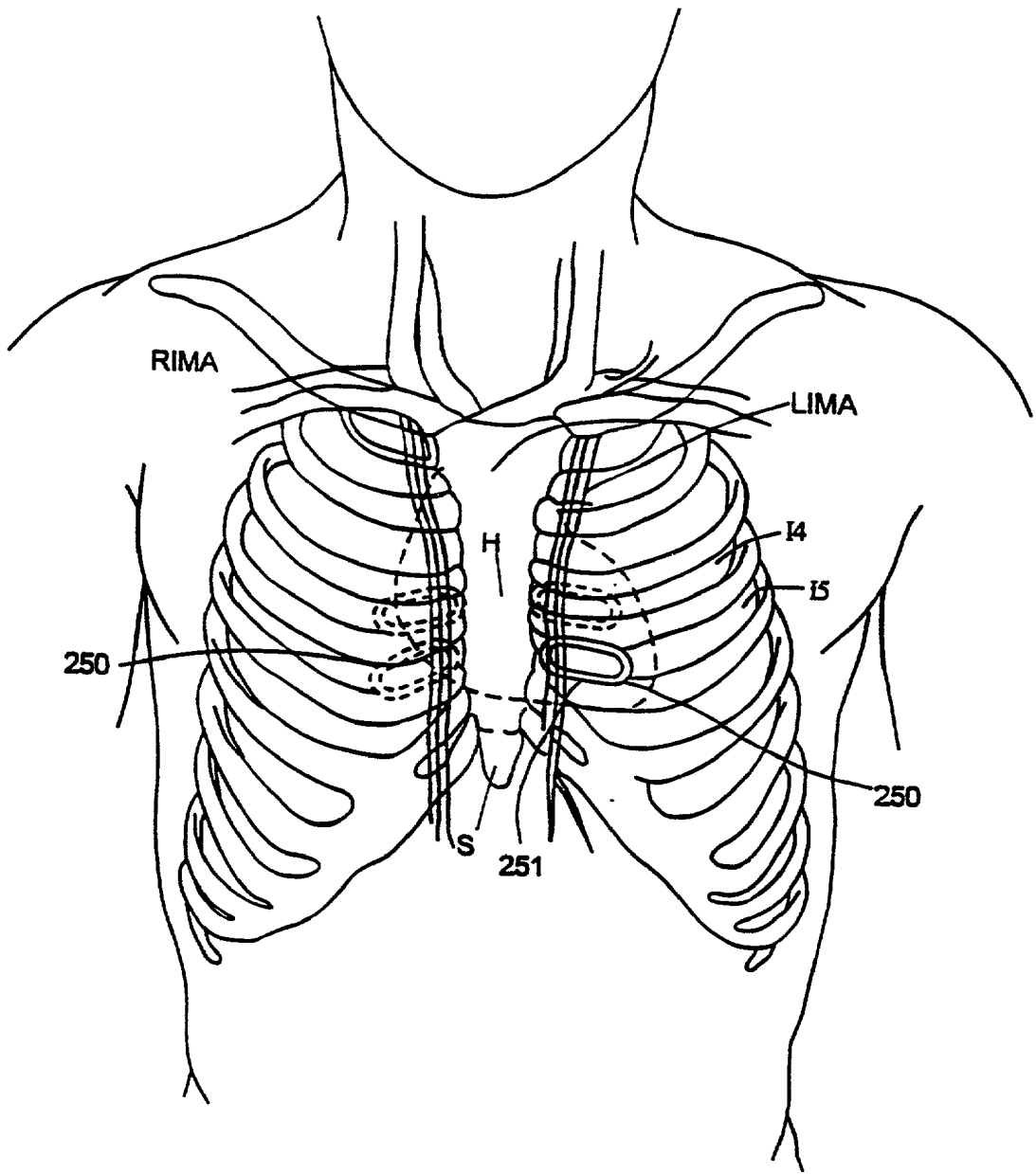

FIG. 48

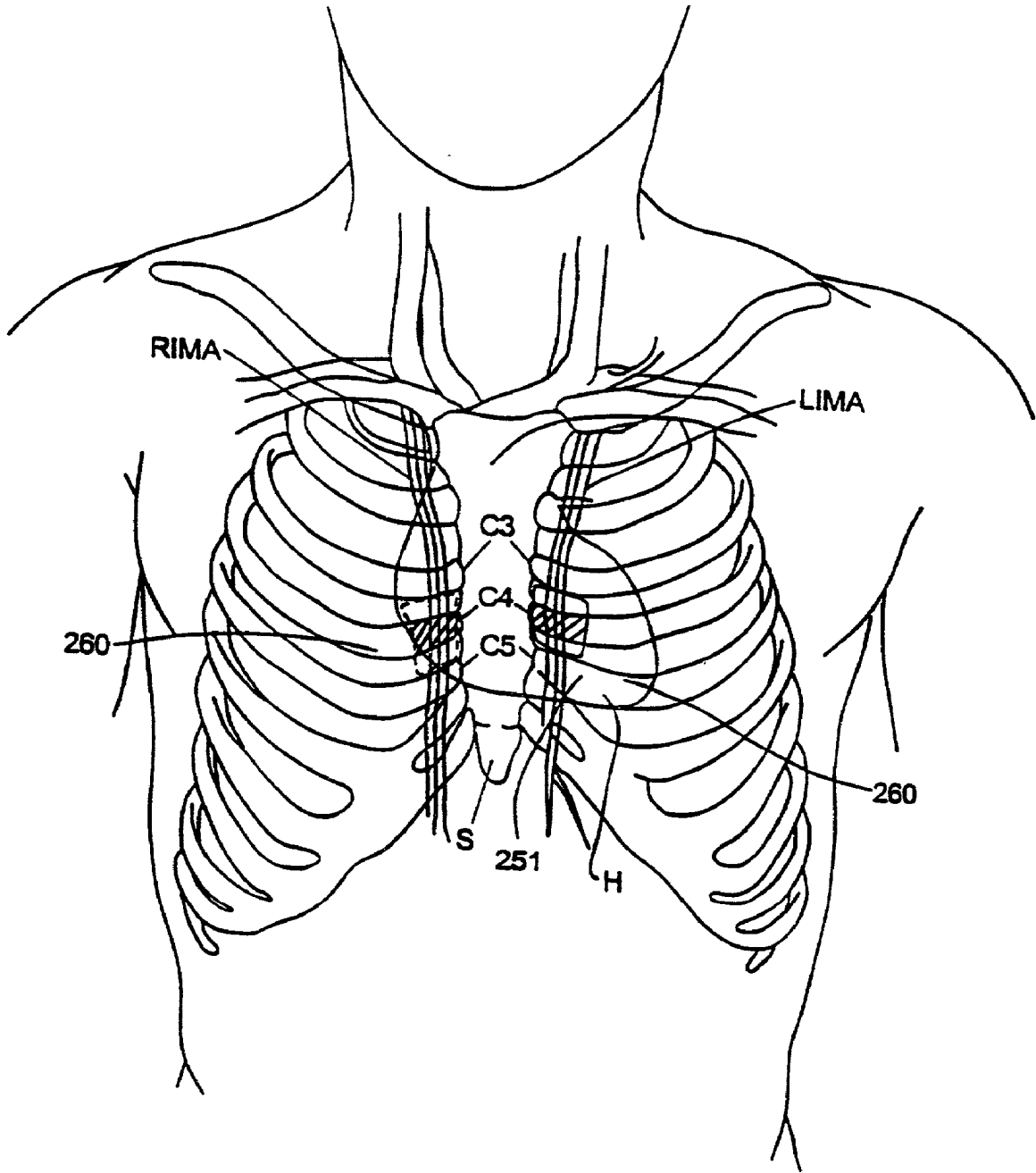
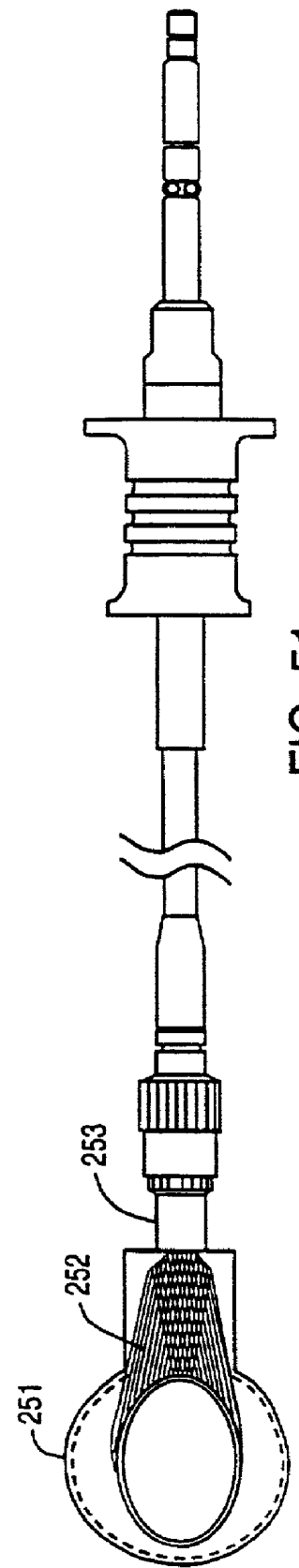
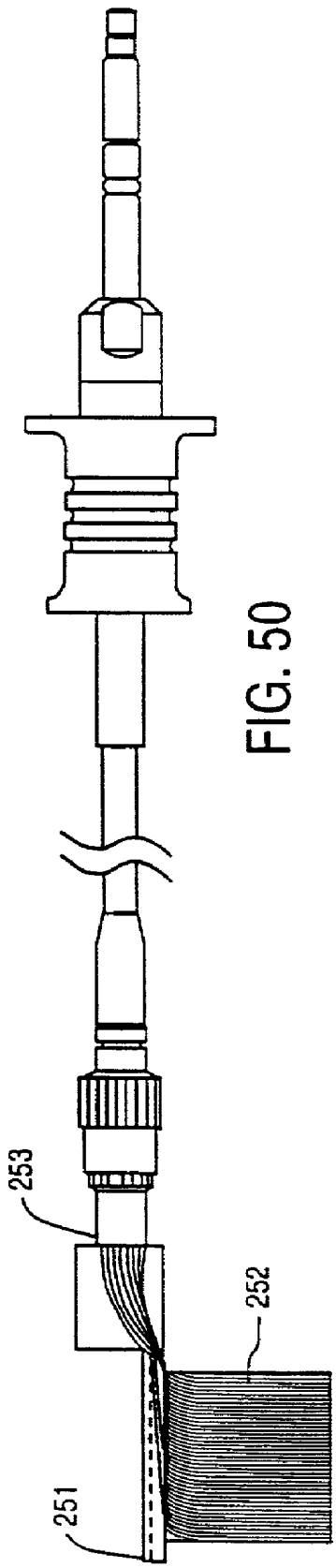

FIG.49



DEVICES AND METHODS FOR PORT-ACCESS MULTIVESSEL CORONARY ARTERY BYPASS SURGERY

[0001] This application is a continuation-in-part of copending U.S. patent application Ser. No. 08/281,891, filed Jul. 28, 1994, which itself is a continuation-in-part of copending U.S. patent application Ser. No. 08/023,778, filed Feb. 22, 1993. The complete disclosures of these related U.S. patent applications are hereby incorporated herein by reference for all purposes.

FIELD OF THE INVENTION

[0002] The present invention relates generally to devices and methods for performing thoracoscopic cardiac procedures. More particularly, the present invention relates to devices and methods for performing coronary artery bypass graft (CABG) surgery for multivessel coronary artery disease through port-access or closed-chest thoracoscopic methods.

BACKGROUND OF THE INVENTION

[0003] Coronary artery disease remains the leading cause of morbidity and mortality in Western societies. Coronary artery disease is manifested in a number of ways. For example, disease of the coronary arteries can lead to insufficient blood flow resulting in the discomfort and risks of angina and ischemia. In severe cases, acute blockage of coronary blood flow can result in myocardial infarction, leading to immediate death or damage to the myocardial tissue.

[0004] A number of approaches have been developed for treating coronary artery disease. In less severe cases, it is often sufficient to treat the symptoms with pharmaceuticals and lifestyle modification to lessen the underlying causes of disease. In more severe cases, the coronary blockage(s) can often be treated endovascularly using techniques such as balloon angioplasty, atherectomy, laser ablation, stents, hot tip probes, and the like.

[0005] In cases where pharmaceutical treatment and/or endovascular approaches have failed or are likely to fail, it is often necessary to perform a coronary artery bypass graft procedure using open surgical techniques. Such techniques require that the patient's sternum be opened and the chest be spread apart to provide access to the heart. A source of arterial blood is then connected to a coronary artery downstream from an occlusion while the patient is maintained under cardioplegia and is supported by cardiopulmonary bypass. The source of blood is often the left or right internal mammary artery, and the target coronary artery can be the left anterior descending artery, circumflex artery, right coronary artery or any one of their branches which might be narrowed or occluded.

[0006] While very effective in many cases, the use of open surgery to perform coronary artery bypass grafting is highly traumatic to the patient. The procedure requires immediate postoperative care in an intensive care unit, a total period of hospitalization of seven to ten days, and a recovery period that can be as long as six to eight weeks.

[0007] It would therefore be desirable to provide other, less traumatic methods and techniques for performing coronary artery bypass grafting. It would be particularly desir-

able if such techniques did not require opening of the patient's sternum, and might be even more desirable if such techniques could be performed using thoracoscopic methods. Such thoracoscopic methods could decrease morbidity and mortality, cost, and recovery time when compared to conventional open surgical coronary bypass procedures. In addition, such methods could be even more efficacious than open-surgical bypass procedures.

[0008] Treatment of multivessel coronary artery disease involves rerouting multiple conduits to supply blood to the blocked coronary arteries downstream of the blockages. Typical conduits used for CABG surgery in multivessel disease include arterial conduits, such as the left internal mammary artery (LIMA), the right internal mammary artery (RIMA) or the right gastroepiploic artery (RGEA), or venous conduits such as the greater saphenous vein (GSV) or the lesser saphenous vein (LSV). Often a combination of these and other conduits is necessary to achieve complete revascularization of the obstructed coronary arteries. Open-chest approaches to treatment of multivessel coronary artery disease are described in *Alternative Bypass Conduits and Methods for Surgical Coronary Revascularization*, by Grooters and Nishida, Futura Publishing Company, Inc., Armonk, N.Y., 1994. Other references for standard open-chest methods of coronary artery bypass surgery include: *Cardiac Surgery*, by Kirklin and Barratt Boyes, John Wiley & Sons, Inc. New York, 1993 (2nd Ed.), and Rob and Smith's *Operative Surgery, Cardiac Surgery*, The C V Mosby Co., St Louis, Mo., 1983 (4th Ed.).

[0009] A major challenge of thoracoscopic CABG surgery in multivessel disease is the ability to visualize and anastomose all of the coronary arteries through a limited number of access ports in order to minimize the trauma to the patient. This is made more difficult because many of preferred anastomosis sites on the branches of the right coronary artery and the circumflex artery are on the posterior aspect of the heart and therefore are difficult to access and to visualize with the heart in situ. Operating on the heart in situ would require separate access ports for the left coronary artery and each of the right coronary artery and the circumflex artery. Making this many access ports in the patient's chest would undermine the atraumatic aspect of the thoracoscopic approach. In open-chest CABG surgery, this problem is solved by withdrawing the heart from the pericardial sac and manipulating it to expose the arteries on the posterior aspect. No instruments currently exist for manipulating the heart within the closed chest of the patient, making it difficult to duplicate the close-chest procedure with thoracoscopic techniques. Devices and methods are therefore necessary for manipulating the heart within the patient's closed chest to expose each of the coronary arteries for visualization and anastomosis.

[0010] The additional length of time required for performing multiple anastomoses in multivessel CABG surgery also poses difficulties in terms of myocardial preservation during the lengthy procedure. In open procedures additional myocardial protection can be provided by topical hypothermia of the heart to reduce oxygen demand by the myocardium. The instruments and systems currently available for topical hypothermia in cardiac surgery are not suited for thoracoscopic techniques. New devices and methods are therefore

necessary for cooling the heart within the patient's closed chest to extend myocardial preservation during the multi-vessel CABG procedure.

SUMMARY OF THE INVENTION

[0011] The present invention describes devices and methods for performing port-access or closed-chest CABG surgery to treat multivessel coronary artery disease. All of the major steps of the port-access CABG procedure are performed through small percutaneous access ports to avoid the necessity of a median sternotomy or other gross thoracotomy, as required in prior open-chest approaches. The methods of the present invention include the steps of dissecting one or more conduit vessels, preferably arterial conduits, from their native locations, rerouting the conduit vessels to the heart and grafting the conduit vessels onto the blocked coronary arteries downstream of the blockages.

[0012] Generally, the step of dissecting the conduit vessels from their native locations or the "takedown" is performed through small access ports using endoscopic visualization. In the case of a LIMA or RIMA takedown, the access ports are made into the patient's thoracic cavity through the intercostal spaces and visualization is achieved using a flexible thoracoscope. Rerouting the LIMA involves redirecting the distal end of the LIMA to the desired anastomosis site. The RIMA may be rerouted anteriorly of the heart or it may be tunneled through the transverse sinus to reach the desired anastomosis site. In the case of an RGEA takedown, the access ports are made into the patient's abdomen and visualization is achieved using a laparoscope. Rerouting the RGEA involves tunneling the distal end of the RGEA through a hole in the diaphragm to reach the desired anastomosis site on the heart. If venous grafts, such as the GSV, or other free grafts are used in place of or in addition to the arterial conduits, then the takedown or harvesting of the graft is performed by open or closed surgical techniques as appropriate and the graft is rerouted to the patient's chest for anastomosis.

[0013] Specialized instruments for facilitating the takedown and rerouting steps are provided as part of the present invention. One instrument provided is a thoracoscopic tunneler for directing an arterial conduit through the transverse sinus or other tunneling path. One embodiment of a tunneler has an elongated shaft with a curved, rigid distal end with a hole through the distal tip for passing a tape or silastic tube through the transverse sinus to retract the aorto-pulmonary trunk to facilitate passage of the arterial conduit through the transverse sinus. Another embodiment of a tunneler has an elongated shaft with an articulated distal end with a grasper for reaching through the transverse sinus to grasp the arterial conduit and draw it through the transverse sinus to the desired anastomosis site. The two tunneling instruments may be used separately or in combination. In addition, a specialized thoracoscopic electro-surgical device may be provided to facilitate takedown of the arterial conduits. A suitable thoracoscopic electro-surgical device for this application is described in co-owned, copending patent application, Ser. No. 08/336,359, filed Nov. 8, 1994. the entire disclosure of which is hereby incorporated by reference.

[0014] The step of grafting the conduit vessels onto the heart is accomplished under direct visualization using a cardioscopic microscope inserted through a visualization

port into the patient's thoracic cavity made through an intercostal space in the anterior wall of the chest. Additional surgical instruments are inserted through auxiliary ports into the patient's thoracic cavity to perform the anastomosis of the conduit vessels to the coronary arteries. The devices and methods of the present invention are devised to minimize the trauma to the patient by making it possible to visualize and access all aspects of the heart from a single centrally located visualization port by manipulating the heart within the patient's closed chest with instruments inserted through the auxiliary access ports or through the takedown ports which remain from the takedown step. Generally, the distal end of each conduit vessel or graft is anastomosed to a coronary artery downstream of a blockage. Additionally, the conduit vessels may be sequentially grafted to more than one coronary artery or branch to form a "skip graft". If free grafts are used an additional step of creating a proximal anastomosis must be performed. The proximal end of the graft may be anastomosed to the ascending aorta or to another of the conduit vessels to form a Y-graft. The step of making the proximal anastomosis may be performed before or after the distal anastomosis, depending on the preferences of the surgeon.

[0015] Specialized instruments are provided for manipulating the heart within the closed chest of the patient to rotate the desired anastomosis site into the visual field of the cardioscopic microscope. The specialized instruments include retractors which can manipulate the heart from outside of the body through one or more of the access ports. One embodiment of a retractor has an elongated shaft with a handle at the proximal end and a curved, finger-like manipulator at the distal end. The curved, finger-like manipulator may be covered with an absorbent and/or frictional material to improve its effectiveness at retracting, rotating and manipulating the heart. Another embodiment of a retractor has an elongated tubular shaft with a suction cup-shaped manipulator at the distal end. A vacuum is applied between the suction cup manipulator and the surface of the heart to grip the heart. The distal surface of the suction cup manipulator may have a textured or highly frictional surface to increase the grip on the surface of the heart, especially in a direction tangential to the surface. The retractor can thus be used to retract or rotate the heart in any direction to expose the desired anastomosis site.

[0016] Another aspect of the present invention is to provide myocardial protection to the heart for the duration of the surgical procedure. A first component of the myocardial protection is to provide a means for establishing cardiopulmonary bypass (CPB) without the need for performing a thoracotomy or other grossly invasive procedure. One non-invasive method of establishing CPB involves the insertion of an endoaortic occlusion catheter into the ascending aorta through a percutaneous puncture into a peripheral artery. An inflatable occlusion balloon on the distal end of the catheter is used to partition the ascending aorta between the coronary ostia and the brachiocephalic artery to isolate the heart and coronary arteries from the remainder of the arterial system while it is supported on cardiopulmonary bypass. Cardioplegic solution to temporarily stop the heart from beating may be infused into the coronary arteries through the catheter and/or through a retroperfusion catheter percutaneously inserted in the coronary sinus. This method is more completely described in co-owned, copending patent application Ser. No. 08/281,891, filed Jul. 28, 1994.

[0017] Another relatively noninvasive method of establishing CPB involves using a thoracoscopic cross-clamp to isolate the heart and coronary arteries from the remainder of the arterial system while it is supported on cardiopulmonary bypass. The thoracoscopic cross-clamp is inserted into the patient's thoracic cavity through an access port. Co-owned, copending patent application Ser. No. 08/173,899, filed Dec. 27, 1993, the entire disclosure of which is hereby incorporated by reference, describes a specialized thoracoscopic cross-clamp suitable use with the present invention and a method of its use for isolating the heart and establishing CPB.

[0018] A second component of the myocardial protection is to provide a means for applying topical hypothermia to the heart to reduce oxygen demand by the myocardium while the patient is on cardiopulmonary bypass and particularly while the heart is under cardioplegic arrest. A specialized topical hypothermia system that can be applied thoracoscopically through small access ports into the chest is provided as part of the present invention. The topical hypothermia system includes a flexible heat exchanger which is collapsible to fit through an access cannula inserted into an intercostal space. The heat exchanger is deployable to an expanded position once it is inside of the thoracic cavity. The heat exchanger is placed in thermal contact with the heart and a cooling fluid is circulated from outside the body through cooling passages within the heat exchanger. The temperature of the heart can be lowered for the duration of the procedure to reduce oxygen demand. The heat exchanger can also be used for warming the heart at the end of the procedure by circulating a warm fluid through the cooling passages.

BRIEF DESCRIPTION OF THE DRAWINGS

[0019] FIG. 1 shows the takedown step for using the left internal mammary artery (LIMA) or the right internal mammary artery (RIMA) as an arterial bypass conduit.

[0020] FIG. 2 shows the tunneling of the RIMA through the transverse sinus (TS).

[0021] FIG. 3 shows the laparoscopic takedown of the right gastroepiploic artery (RGEA).

[0022] FIG. 4 shows the tunneling of the RGEA through the diaphragm into the thoracic cavity.

[0023] FIG. 5 shows the operative ports for performing the anastomosis of the arterial conduits onto the coronary arteries.

[0024] FIG. 6 shows a position of the heart for performing an anastomosis to the right coronary artery (RCA) or the posterior descending (PDA) branch.

[0025] FIG. 7 shows an alternate position of the heart for performing an anastomosis to the RCA or the PDA.

[0026] FIG. 8 shows the position of the heart for performing an anastomosis to the circumflex artery (Cx) or the obtuse marginal (OM) branches.

[0027] FIG. 9 shows the position of the heart for performing an anastomosis to the left anterior descending artery (LAD).

[0028] FIGS. 10-15 show the step-by-step sequence of creating an end-to-side anastomosis.

[0029] FIG. 16 shows the heart of the patient with multiple completed bypass grafts.

[0030] FIGS. 17-18 show the step-by-step sequence of creating a side-to-side anastomosis.

[0031] FIG. 19 shows the heart of the patient with sequential anastomoses on a "skip graft".

[0032] FIG. 20 shows the heart of the patient with a saphenous vein bypass graft.

[0033] FIG. 21 shows the heart of the patient with a Y-graft.

[0034] FIG. 22 shows a first embodiment of a tunneler for retracting the pulmonary trunk away from the transverse sinus.

[0035] FIG. 23 shows a schematic diagram of a patient's heart with the tunneler of FIG. 22 in use.

[0036] FIG. 24 shows a second embodiment of a tunneler having an articulating distal end.

[0037] FIG. 25 is an enlarged detail drawing of the multilink articulator on the distal end of the articulating tunneler of FIG. 24.

[0038] FIG. 26 shows an embodiment of the articulating tunneler of FIG. 24 with a grasper on the distal end for grasping the RIMA and drawing it through the transverse sinus.

[0039] FIG. 27 shows a schematic diagram of a patient's heart with the articulating tunneler of FIG. 26 in use.

[0040] FIG. 28 shows a first embodiment of a heart retractor with a finger-like manipulator on the distal end.

[0041] FIG. 29 shows an alternate embodiment of a heart retractor having a finger-like manipulator combined with a suction irrigation lumen.

[0042] FIG. 30A shows a die-cutting pattern for the covering material to cover the finger-like manipulator of FIG. 28.

[0043] FIG. 30B shows an enlarged detail drawing of the die-cutting pattern of FIG. 30A.

[0044] FIG. 31 shows a cross section of a patient showing the heart retractor of FIG. 28 in use.

[0045] FIG. 32 shows the heart retractor of FIG. 28 fixed to the operating table to stabilize the heart.

[0046] FIG. 33A shows a side view of a second embodiment of a heart retractor having a suction cup-shaped manipulator on the distal end. FIG. 33B shows a longitudinal cross section of the distal end of the heart retractor of FIG. 33A. FIG. 33C shows a distal end view of the heart retractor of FIG. 33A.

[0047] FIG. 34 shows a cross section of a patient showing the heart retractor of FIG. 33 in use.

[0048] FIG. 35 shows the heart retractor of FIG. 33 used to rotate the heart to expose the Cx and the OM branches on the left aspect of the heart.

[0049] FIG. 36 shows a third embodiment of a heart retractor with a flexible snare on the distal end for manipulating the heart.

[0050] FIG. 37 shows the heart retractor of FIG. 36 in a predeployed position for insertion through an access cannula.

[0051] FIG. 38 shows a cross section of a patient showing the heart retractor of FIG. 36 in use.

[0052] FIG. 39 shows a fourth embodiment of a heart retractor for manipulating the heart in a predeployed position for insertion through an access cannula.

[0053] FIG. 40 shows the heart retractor of FIG. 39 in a deployed position for manipulating the heart.

[0054] FIG. 41 shows a cross section of a patient showing the heart retractor of FIG. 39 in use.

[0055] FIG. 42 shows a first embodiment of a topical hypothermia device for cooling a patient's heart to improve myocardial protection during port-access cardiac surgery.

[0056] FIG. 43 shows the topical hypothermia device of FIG. 42 in a predeployed position for insertion through an access port.

[0057] FIG. 44 shows the topical hypothermia device of FIG. 42 in a deployed position.

[0058] FIG. 45 shows the topical hypothermia device of FIG. 42 in use within the chest of a patient.

[0059] FIG. 46 shows a second embodiment of a topical hypothermia device for cooling a patient's heart to improve myocardial protection during port-access cardiac surgery.

[0060] FIG. 47 shows the topical hypothermia device of FIG. 46 in a deployed position.

[0061] FIG. 48 shows a first embodiment of an anterior mediastinotomy approach for performing closed-chest multivessel CABG surgery.

[0062] FIG. 49 shows a second embodiment of an anterior mediastinotomy approach for performing closed-chest multivessel CABG surgery.

[0063] FIG. 50 shows a top view of a fiberoptically illuminated oval access cannula.

[0064] FIG. 51 shows a side view of the fiberoptically illuminated oval access cannula of FIG. 50.

DETAILED DESCRIPTION OF PREFERRED EMBODIMENTS

[0065] The Surgical Method

[0066] FIG. 1 is a schematic view of a patient's thorax illustrating the takedown step of the port-access CABG procedure. The takedown step should be performed while the patient is under general anesthesia, but before the patient has been placed on cardiopulmonary bypass. If the LIMA is to be used as an arterial bypass conduit, a series of access ports are created on the left lateral side of the patient's chest, as shown in FIG. 1. The access ports are created by incising the skin with a scalpel between two of the patient's ribs, then an access cannula 112 with a trocar is pushed through the intercostal space. Preferably, a self-anchoring access cannula 112 with a 10-12 mm internal diameter is used for the takedown ports. The placement of the access ports is highly variable, depending on the preferences of the surgeon and

the anatomy of the patient which is assessed fluoroscopically before the operation to verify the preferred locations.

[0067] In one preferred embodiment of the method, to allow the takedown of the LIMA, a first access port 103 is placed in the third intercostal space I3 on the left lateral side of the patient's chest, a second access port 104 is placed in the fifth intercostal space I5, and a third access port 105 is placed in the sixth intercostal space I6 in a slightly more anterior position from the first two. Meanwhile, the left and right bronchi are individually intubated just below the bifurcation of the trachea so that the lungs can be individually ventilated. The left lung is deflated to provide clearance between the lung and the left anterior wall of the thoracic cavity while the patient is ventilated through the right lung. A flexible thoracoscope 111 is inserted through one of the access ports, such as the third access port 105 as shown in FIG. 1. The distal end of the flexible thoracoscope 111 can be directed toward the anterior wall of the thoracic cavity just to the left of the sternum S to view the LIMA. Elongated instruments, such as an electrosurgical device 110 and a grasper 109, are inserted through the remaining ports 104, 103 to dissect the LIMA from the anterior wall of the chest. The LIMA is dissected with an attached pedicle. Side branches of the LIMA are ligated with ligating clips, applied with a thoracoscopic clip applicator, as the LIMA is dissected from the surrounding tissue. A length of LIMA of 15-30 cm is dissected from the wall to provide enough length to reach the chosen anastomosis site. When a sufficient length of LIMA has been dissected, two ligating clips are placed side-by-side near the distal end of the LIMA and the vessel is transected between them.

[0068] If the patient's lungs are ventilated by high frequency "jet" ventilation, then the RIMA can also be harvested from the access ports 103, 104, 105 on the left side of the patient's chest, provided the patient's chest has ample space between the heart and the anterior wall of the thoracic cavity. To do this, both lungs are partially deflated while continuing to ventilate, thereby allowing clearance to reach the RIMA from the left side of the chest. After dissecting the mediastinal pleura, the distal end of the thoracoscope 111 is directed toward the anterior wall of the thoracic cavity just to the right of the sternum S to view the RIMA and the RIMA is taken down in a similar fashion to the LIMA.

[0069] If conventional ventilation is used, sufficient ventilation cannot be achieved with both lungs partially deflated, so this option is not available. In this case, access ports 106, 107, 108 symmetrical to the left hand ports are placed in the lateral right side of the chest, typically in the third I3, fifth I5 and sixth I6 intercostal spaces. The right lung is deflated to provide clearance between the lung and the anterior wall of the thoracic cavity while the left lung is ventilated. The flexible thoracoscope 111 is inserted through one of the access ports and instruments, such as the electrosurgical device 110, graspers 109 and/or a clip applicator, are inserted through the remaining ports to dissect the RIMA from the anterior chest wall. A length of 15-30 cm of RIMA with an attached pedicle is dissected from the chest wall to provide enough length to reach the chosen anastomosis site. When a sufficient length of RIMA has been dissected, two ligating clips are placed side-by-side near the distal end of the RIMA and the vessel is transected between them.

[0070] When rerouting the RIMA to the anastomosis site, two paths are possible. The currently preferred path is

through the transverse sinus TS which is a natural passage behind the aorta A and the pulmonary artery P leading from the right side of the heart H to the left side. The RIMA is tunneled through the transverse sinus TS by passing an instrument, such as the articulated tunneling grasper 150 described below in relation to FIG. 24, through the transverse sinus TS and drawing the distal end of the RIMA back through the transverse sinus TS, as shown in FIG. 2. (nota bene: The patient's chest has been shown with the ribs R cut away in FIG. 2, and subsequent figures, solely for the purposes of illustration. An important feature of the port-access surgical method of the present invention is that the ribs and the sternum remain intact throughout the surgical procedure.) To facilitate the tunneling operation, a tunneler 140, such as the one described below in relation to FIG. 22, can be used to retract the pulmonary trunk P to allow easier passage of the RIMA through the transverse sinus TS. The second path for rerouting the RIMA is across the anterior side of the heart H. This routing of the RIMA is not currently preferred by most surgeons in open-chest CABG operations because the oscillating saw commonly used for doing the sternotomy in redo CABG operations can cause damage to the RIMA if it is placed in an anterior position. However, it is interesting to note that redo CABG will not require the oscillating saw to open the sternotomy if the original CABG operation was done with port-access techniques that do not require a sternotomy. The less traumatic reciprocating saw, commonly used in first time CABG surgery, can be used if a redo operation is necessary because it will be the patient's first sternotomy. As the techniques for port-access CABG surgery advance, the simpler anterior route for the RIMA is likely to become the preferred path.

[0071] If a third arterial conduit is required for complete revascularization of the heart or if either of the internal mammary arteries is not available, then the right gastroepiploic artery (RGEA) is the next choice. FIG. 3 shows the laparoscopic takedown step for the RGEA. A first laparoscopic access port 113 is placed above the umbilicus and a second laparoscopic access port 114 is placed below the diaphragm. A third 115 and fourth 116 access ports may be placed in the left and right side of the abdomen as shown for insertion of instruments. The RGEA is dissected from the greater curvature of the stomach ST using an electro-surgical device. Ligating clips are placed on branches of the RGEA running toward the omentum. Branches 117 running toward the stomach are preferably ligated with suture. A length of 15-30 cm of RGEA with an attached pedicle is dissected from the stomach to provide enough length to reach the chosen anastomosis site. When a sufficient length of RGEA has been dissected, two ligating clips 118 are placed side-by-side near the distal end of the RGEA and the vessel is transected between them.

[0072] A hole 119 is made through the diaphragm D in an appropriate place for reaching the desired anastomosis site using an electro-surgical device. The distal end of the RGEA is tunneled upward through the diaphragm D as shown in FIG. 4. In FIG. 4, the rerouted RGEA is shown being anastomosed to the PDA on a heart H which has been retracted by the methods described below to expose the posterior aspect of the heart.

[0073] If a venous graft, such as the greater saphenous vein (GSV), is needed, a venous takedown procedure can be performed by known techniques to provide a venous con-

duit. After harvesting, the vein can be prepared for use as a graft outside of the body and inserted into the thoracic cavity through one of the access ports at the appropriate time in the grafting step of the procedure.

[0074] Simultaneously with the takedown step or steps just described, the patient can be prepared for cardiopulmonary bypass by cannulating the femoral artery and the femoral vein using surgical cutdowns or the percutaneous Seldinger technique. Additionally, an endoaortic occlusion catheter may be positioned in the ascending aorta according to the methods described in co-owned, copending patent application Ser. No. 08/281,891, filed Jul. 28, 1994. According to the methods described therein, an elongated endoaortic occlusion catheter is introduced into a peripheral artery, such as the femoral artery and advanced into the ascending aorta. When it is time to establish CPB before the grafting step described below, an occlusion balloon on the distal end of the catheter is inflated to occlude the aortic lumen between the coronary ostia and the brachiocephalic artery. Once the balloon is inflated a cardioplegic agent can be infused through a lumen in the catheter into the aortic root and into the coronary arteries to induce cardiac arrest. Alternatively, a thoracoscopic cross-clamp may be introduced through one of the access ports according to the methods described in co-owned, copending patent application Ser. No. 08/173,899, filed Dec. 27, 1993, the entire disclosure of which is hereby incorporated by reference. According to the methods described therein, an elongated thoracoscopic cross-clamp is introduced through one of the access ports and, at the appropriate time, clamped around the ascending aorta to occlude the aortic lumen. A cardioplegic agent may be introduced antegrade into the aortic root or retrograde through the coronary sinus to induce cardiac arrest. This is in preparation for the grafting step of the method of the present invention which follows.

[0075] At this point in the procedure the pericardium is opened to expose the heart as completely as possible. Using thoracoscopic observation, grasping instruments and cutting instruments, such as knives, scissors and/or an electro-surgical device are inserted through the takedown ports 103, 104, 105 and a vertical slit beginning at or near the aortic reflection and extending to the apex of the heart is made in the pericardium. Thoracoscopic bipolar electro-surgical cutting scissors, such as model 3803 bipolar scissors from Everest Medical Corporation, Minneapolis, Minn., have proven to be an effective instrument for performing the pericardiotomy. The pericardium is divided to expose the surface of the heart H to view.

[0076] FIG. 5 shows the operative ports for performing the anastomosis of the arterial conduits onto the coronary arteries. A visualization port 120 is placed in the anterior wall of the chest, typically through the fourth intercostal space 14, about 1-3 cm from the sternum S. The precise placement of the visualization port 120 is determined by the position of the heart H within the patient's chest. A probe, such as a 22 gauge needle can be inserted percutaneously through the intercostal space while observing the anterior wall of the thoracic cavity through the thoracoscope. When the needle is observed entering the thoracic cavity above the target position, for instance above the LAD when the heart is in its native position, the needle is removed and a trocar is used to create an access port at that position. An access cannula 121 with an internal diameter of 10-12 mm is placed

in the access port **120** and the cardioscopic microscope (not shown) is inserted through the cannula. A cardioscopic microscope, adapted especially for this port-access CABG procedure is available from Karl Zeiss, GmbH, Germany. The presently preferred configuration uses an OPMI® microscope, model MDU or CS, with an NC31 microscope stand, an endoscopic adapter and a Port-Access Stereo vision Probe. Other types of microscope-based and direct visualization systems which are particularly well-suited for use in the method of the present invention are disclosed in co-owned, copending patent applications Ser. No. 08/135,387, filed Oct. 8, 1993, and Ser. No. 08/227,366, filed Apr. 13, 1994, the complete disclosures of which are hereby incorporated herein by reference. With the microscope positioned in the visualization port **120**, the left anterior descending coronary artery (LAD) should be within the field of view of the microscope.

[**0077**] A number of instrument ports **122** are placed about 3-5 cm from the visualization port to allow proper angulation of the instruments into the field of view of the microscope. Typically, two ports **122** are placed near the sternum S in the third **I3** and fourth **I4** intercostal spaces and two more ports **122** are placed to the left of the visualization port in the third **I3** and fifth **I5** intercostal spaces. An access cannula **123** with an internal diameter of 5 mm is placed in each of the instrument ports **122**.

[**0078**] Next the graft vessels, whether arterial or venous conduits, must be prepared for anastomosis. Preferably, the distal ends of the graft vessels are prepared outside of the body by passing the distal end of the graft out through one of the access ports. This simplifies the procedure because the end of the graft can be prepared under direct visualization with magnifying surgical loupes and because standard surgical instruments can be used for preparing the graft rather than thoracoscopic instruments. The LIMA or RIMA can be passed out through one of the thoracic access ports (e.g. access port **103** or **106** in **FIG. 1**) before rerouting or tunneling the vessel. The RGEA can be passed out through one of the abdominal access ports (e.g. access port **113** or **114** in **FIG. 3**) before tunneling the RGEA through the diaphragm D. If the graft vessel is too short to reach the exterior of the body through one of the access ports, the following graft vessel preparation procedure can also be carried out within the thoracic cavity using thoracoscopic instruments and techniques. Prior to preparing the graft vessel, the blood flow into the vessel must be stopped by placing an atraumatic clamp (e.g. **124** in **FIG. 4**) on the upstream end of the vessel. An atraumatic thoracoscopic bulldog clamp especially suited for this step of the procedure is described in co-owned, copending patent application Ser. No. 08/265,477, filed Jun. 24, 1994.

[**0079**] The graft vessel should be prepared by first determining the appropriate length of the conduit in order to reach the desired anastomosis site. The distal end of the graft vessel should then be skeletonized by stripping the pedicle away from the artery for 5-10 mm. The distal end of the artery is transected to remove the ligating clip **118** that was previously applied. If desired, Papavarin may be injected into the lumen of the artery to dilate it and reverse any arterial spasm. Depending on the technique preferred by the surgeon, the distal end of the graft vessel can be slit longitudinally to create a cobra head for the anastomosis.

Once prepared, the graft vessel is reinserted into the thoracic cavity through the access port.

[**0080**] When performing multiple anastomoses, it is preferable to do the most difficult or most difficult to reach anastomosis first. For example, any anastomosis to the RCA or the PDA should be performed first since the most retraction of the heart is necessary. Following that, any anastomosis to the Cx or the OM branches should be performed. Finally, any anastomosis to the LAD can be performed last. The RIMA, RGEA or a vein graft may be used for anastomosis to the RCA or the PDA which are on the posterior aspect of the heart. Typically, the LIMA, RIMA or a vein graft is used when a graft is needed for the Cx or the OM branches because of their location on the left aspect of the heart. The LIMA, or the RIMA if the LIMA has already been used for the Cx, may be used for anastomosis to the LAD which is on the anterior aspect of the heart. Because the manifestations of coronary artery disease are highly variable, the extent of the disease should be assessed fluoroscopically beforehand and the anastomosis sites and the best use of the available conduits strategized carefully. The procedures for anastomosing to each of the major anastomosis sites will now be described. These procedures can be performed in combination to achieve complete revascularization of the heart.

[**0081**] **FIG. 6** shows a first position of the heart H for performing an anastomosis to the right coronary artery (RCA) or the posterior descending (PDA) branch. The heart H is manipulated from outside of the body using instruments inserted through the instrument ports **122** or the takedown ports **103**, **104**, **105** in the patient's chest. Using the heart retractor devices described below in connection with **FIGS. 26 and 27** or any suitable means for manipulating the heart from outside of the body, the heart H is rotated approximately 180 degrees to the left of the patient to position the RCA and/or PDA under the microscope in the visualization port **120**. With the heart H stabilized in this position, the distal extremity of the conduit vessel is approximated to the chosen anastomosis site and an end-to-side anastomosis is performed. The likely graft vessels for the RCA and the PDA, which include the RIMA and the RGEA, are shown in phantom lines in **FIG. 6**. After completion of the anastomosis, the heart H is rotated back to its native position or to the desired position for the next anastomosis.

[**0082**] **FIG. 7** shows an alternate position of the heart H for performing the anastomosis to the RCA or the PDA. In this variation of the procedure, the heart H is rotated approximately 180 degrees about an axis **125** which is at an approximately 45 degree angle to the sagittal axis of the body. Flipped upward this way, the RCA and the PDA are positioned under the microscope in the visualization port **120**. With the heart H stabilized in this position, the distal extremity of the conduit vessel is approximated to the chosen anastomosis site and an end-to-side anastomosis is performed. The likely graft vessels for the RCA and the PDA, which include the RIMA and the RGEA, are shown in phantom lines in **FIG. 7**. After completion of the anastomosis, the heart H is rotated back to its native position or to the desired position for the next anastomosis.

[**0083**] **FIG. 8** shows the position of the heart H for performing an anastomosis to the circumflex artery (Cx) or the obtuse marginal (OM) branches. In order to access the

Cx or the OM branches which are on the left aspect of the heart or the left posterior aspect of the heart, the heart H is rotated toward the right by 45 to 90 degrees using retraction instruments inserted through the access ports (e.g. **103**, **104**, **105**). In this position the Cx and/or the OM branches will be positioned under the microscope in the visualization port **120**. With the heart H stabilized in this position, the distal extremity of the conduit vessel is approximated to the chosen anastomosis site and an end-to-side anastomosis is performed. The likely graft vessels for the Cx and the OM branches, which include the LIMA and the RIMA, are shown in phantom lines in **FIG. 8**. After completion of the anastomosis, the heart H is rotated back to its native position or to the desired position for the next anastomosis.

[**0084**] With the more difficult to reach anastomoses completed and the heart H back in its native position, as shown in **FIG. 9** the anastomosis to the LAD can now be completed. With the heart H in its native position, the LAD will be positioned under the microscope in the visualization port **120**. With the heart H stabilized in this position, the distal extremity of the conduit vessel is approximated to the chosen anastomosis site and an end-to-side anastomosis is performed. The likely graft vessels for the LAD, which include the LIMA and the RIMA, are shown in phantom lines in **FIG. 9**.

[**0085**] Alternatively to manipulating the heart within the closed chest to expose the different aspects, a second visualization port **126** and instrument ports **127** can be opened on the right side of the chest, as shown in phantom lines in **FIG. 5**, to access the right coronary artery RCA directly. In another alternative approach, right side access ports may be used alone if only the right coronary artery RCA and/or the obtuse marginal OM branches are to be revascularized or if the patient's anatomy favors a right side approach for multivessel revascularization.

[**0086**] **FIGS. 10-15** show the step-by-step sequence of creating an end-to-side anastomosis. Referring now to **FIG. 10**, an incision **95** is made in the wall of the coronary artery CA, where the incision has dimensions selected to match those of the distal end of the internal mammary artery graft IMA. The incision **95** is made by first piercing the arterial wall using the tip of a scalpel (not illustrated). Scissors **96** are then introduced through the penetration and used to axially extend the penetration, as illustrated at **97** in **FIG. 11**.

[**0087**] The internal mammary artery IMA can be joined to the extended incision **97** in the coronary artery CA by a variety of techniques, including suturing, laser welding, microstapling, and the like. In a currently preferred embodiment of the method of the present invention, it is preferred to use a continuous suturing technique as illustrated in **FIGS. 10-15**. A length of suture **98** has needles **100** at either end, which are manipulated using forceps **102** to join the distal end **101** of the internal mammary artery IMA graft to the opening created by the incision **97** in the coronary artery CA, as shown in **FIGS. 11-15**. The instrument designs presently preferred for performing the coronary anastomosis are described in copending application Ser. No. 08/194,946, filed Feb. 11, 1994, the entire disclosure of which is hereby incorporated herein by reference. Alternatively, an interrupted suture technique for the anastomosis can be used, as described in Rob and Smith's *Operative Surgery, Cardiac Surgery* for open-chest CABG surgery.

[**0088**] The presently preferred suture for port-access CABG surgery is a double-armed suture of 8-10 cm length which was specially developed for this procedure. The suture **98** has a first needle **100** on one end and a second needle **100** on the other end. Preferably, the needles **100** are $\frac{3}{8}$ circle curved hardened stainless steel needles with tapered points. The needles **100** are preferably attached to the suture **98** by crimping. Alternatively, the needles **100** may be adhesively bonded to be suture **98**. The preferred suture material **98** is a multifilament, expanded PTFE suture material with a size between 8-0 and 6-0 USP, preferably 7-0 USP. Suitable suture material of this type is available from W. L. Gore, Corporation under the tradename Goretex®. A contrasting color which is highly visible within the thoracic cavity, such as black, blue or white, is preferred for the suture material.

[**0089**] The configuration of this suture is especially advantageous for use in the port-access surgical CABG procedure. The suture can be inserted into the thoracic cavity through an access port and manipulated using thoracoscopic needle drivers to sew the anastomosis and to tie the suture within the thoracic cavity. Standard sutures, which are normally much longer, are very difficult to manipulate within the closed chest, especially when tying the suture using thoracoscopic instruments. The short length of the suture allows the knots in the suture to be pulled tight within the confines of the thoracic cavity while grasping the needles with the needle drivers. The multifilament, expanded PTFE suture material is much easier to handle and tie within the confines of the thoracic cavity than monofilament suture material which is generally stiffer and harder to handle. Additionally, the multifilament, expanded PTFE suture material has more resistance to damage than monofilament when it is grasped directly by the needle drivers, as shown in **FIGS. 11, 14** and **15**.

[**0090**] **FIG. 16** shows the heart H of a patient after completion of a total revascularization for multivessel coronary artery disease using port-access techniques. Three bypass grafts have been made, using the LIMA as a bypass to one of the OM branches of the Cx, the RIMA as a bypass to the LAD, tunneled via the transverse sinus TS, and the RGEA as a bypass to the PDA, tunneled through the diaphragm.

[**0091**] A sequential grafting technique or "skip grafting" is useful for achieving total revascularization when the number of significant coronary artery stenoses exceeds the number of available graft conduits. Sequential grafts are created by making a side-to-side anastomosis with a first coronary artery at an intermediate point on the graft vessel, then an end-to-side anastomosis between the distal end of the graft vessel and a second coronary artery. **FIGS. 17-18** show the step-by-step sequence of creating a side-to-side anastomosis between a graft vessel G and a coronary artery CA. The side-to-side anastomosis is fashioned in a diamond-shaped manner, placing the graft vessel arteriotomy **128** at right angles to the coronary arteriotomy **129**. Small arteriotomies, 3-4 mm in length, are used and six to eight continuous stitches **130** are placed through the coronary artery CA and the graft vessel G. An interrupted suture technique can also be used. **FIG. 19** shows the heart H of a patient with a completed sequential graft. The LIMA has been first grafted to the diagonal branch LD of the left

anterior descending coronary artery using a side-to-side anastomosis **131**, then grafted to the LAD with an end-to-side anastomosis **132**.

[0092] Free grafts using either arterial conduits or venous conduits can be used to augment the in situ arterial grafts. Generally, the proximal end of a free grafts is anastomosed to the ascending aorta A to provide an arterial blood source and the distal end of the graft is anastomosed to one of the coronary arteries. A common source of free grafts is the greater saphenous vein. Other conduits used as free grafts include the lesser saphenous vein, the LIMA, the RIMA, the inferior epigastric artery, the splenic artery, the subclavian artery, and others. FIG. 20 shows the heart H of a patient with a saphenous vein bypass graft SVG to the LAD. The proximal anastomosis **133** can be created using suture techniques similar to those described in connection with FIGS. 10-15 above with the exception that a thoracoscopic tissue punch would be used to create an aortotomy after the initial incision with a scalpel. Alternatively, the proximal anastomosis **133** can be created using an anastomosis staple device, such as those described in co-owned, copending patent application Ser. No. 08/394,333, filed Feb. 24, 1995, the entire disclosure of which is hereby incorporated by reference.

[0093] Free grafts can be combined with in situ grafts or other free grafts to create composite bypass grafts to help achieve total revascularization for multivessel disease. For example, a free graft can be anastomosed to the distal end of an in situ graft like the LIMA or RIMA when there is insufficient length of the graft after takedown. Alternatively, a Y-graft can be created as an alternative to the sequential grafts described above. FIG. 21 shows the heart H of a patient with a Y-graft. The Y-graft was created by joining the proximal end of a free right internal mammary artery graft F-RIMA to an intermediate point on a LIMA in situ graft with an end-to-side anastomosis **134**, then grafting the distal end of the RIMA to the Cx with an end-to-side anastomosis **135** and grafting the distal end of the LIMA to the LAD with an end-to-side anastomosis **136**. Other conduits including arterial and venous grafts can be combined in various combinations to create composite grafts.

[0094] Instrument Descriptions

[0095] FIGS. 22-47 show an armamentarium of instruments for facilitating the port-access multivessel CABG procedure. FIG. 22 shows a first embodiment of a tunneler **140** for retracting the pulmonary artery away from the ascending aorta to facilitate tunneling the RIMA through the transverse sinus TS. The tunneler **140** has an elongated shaft **141** of sufficient length to reach the great vessels of the heart from the takedown ports in the left lateral side of the chest, typically 15-30 cm in overall length. There is a handle **142** on the proximal end of the shaft **141**. The distal portion **143** of the shaft is curved to facilitate passing the tunneler **140** through the transverse sinus TS from the left side of the heart. The distal tip **144** of the shaft is rounded to make it atraumatic. There is a hole **145** through the shaft **141** near the distal tip **144** of the tunneler **140**. In use, a silastic tape **146** or elastomeric tube is threaded through the hole **145** and the distal end of the tunneler is inserted through one of the takedown ports (e.g. **103** in FIG. 23). Under thoracoscope observation, the curved distal portion **143** is inserted behind the pulmonary artery P and the ascending aorta A and passed

through the transverse sinus TS to the right side of the heart, as shown in FIG. 23. When the distal tip **144** of the tunneler **140** emerges on the right side of the heart H, a grasper is inserted through one of the access ports, typically one of the takedown ports on the left lateral side of the chest, to grasp one side of the tape **146**. The retractor **140** is withdrawn and the ends of the tape **146** are passed out through the access ports, preferably one of the takedown ports located at the third or fourth intercostal space, and tension is placed on the tape **140** to retract the main pulmonary artery P and the ascending aorta A (the aorto-pulmonary trunk), thereby widening the transverse sinus TS. With the pulmonary artery P and the ascending aorta A retracted, a Grasping instrument, such as the articulated tunneling grasper **150** of FIG. 26, can more easily be reached through the transverse sinus TS.

[0096] A basic embodiment of the articulated tunneling grasper **150** is shown in FIG. 24. The articulated tunneling grasper **150** has an elongated tubular shaft **151** with a handle **152** on the proximal end. A multilink articulator **153** is attached to the distal end of the shaft **151**. The multilink articulator **153** is shown in detail in FIG. 25. The multilink articulator **153** has a head **154** which attaches to the distal end of the shaft **151**. Two links **155**, **156** are pivotally attached to the head **154**. The first link **155** is a straight link. The proximal end of the first link **155** is pivotally attached to the head **154**. The second link **156** is an L-shaped link with a long leg **157** that is approximately the same length as the first link **155**, and a short leg **158** extending perpendicular from the proximal end of the long leg **157**. The second link **156** is pivotally attached to the head **154** at the proximal end of the long leg **157**. An actuator rod **159** that passes through the tubular shaft **151** connects the end of the short leg **158** with a sliding actuator button **160** on the handle **152**. The first link **155** and the second link **156** cross one another and their distal ends are pivotally attached to a third link **161**. The third link **161** is an L-shaped link with a long leg **162** extending distally, and a short leg **163** extending perpendicular from the proximal end of the long leg **162**. When the actuator rod **159** is in its neutral position the multilink articulator **153** is in a relatively straight position, as shown in FIG. 24 by solid lines **153**". When the actuator rod **159** is moved distally with respect to the head **154**, it pivots the second link **156** clockwise, as shown in FIG. 24 by phantom lines **153**". The relative motion of the first **155** and second links **156**, in turn, pivots the third link **161** clockwise, as shown. When the actuator rod **159** is moved proximally with respect to the head **154**, it pivots the second link **156** counterclockwise, as shown in FIG. 24 by phantom lines **153**". The relative motion of the first **155** and second links **156**, in turn, pivots the third link **161** counterclockwise. The distal end of the multilink articulator **153** can thus pivot approximately 90 degrees in either direction.

[0097] Various end effectors can be attached to the distal end of the multilink articulator **153** for performing different tasks. The possible end effectors include a simple hole **164**, as shown in FIG. 24, for placing a tape through the transverse sinus TS for retracting the aorto-pulmonary trunk, or a heart retraction device, such as a suction retractor or finger retractor, as discussed in more detail below, or a grasping mechanism, such as a cable-actuated grasper.

[0098] In one particularly preferred embodiment, shown in FIG. 26, a cable-actuated grasper **165** is mounted on the distal end of the multilink articulator **153** shown in FIG. 24.

The grasper **165** has a first **166** and second **167** jaw with grasping surfaces on the facing surfaces of the jaws **166**, **167**. At least one of the jaws **166**, **167**, and preferably both jaws, are pivotally attached to the distal end of the third link **166**, **167**. An actuator cable (not shown) extends from a control button **168** on the handle **152**, through the tubular shaft, and to a linkage connected to the grasper jaws **166**, **167**. The jaws of the grasper **166**, **167** can be actuated to open and close using the control button **168**.

[0099] In use, the articulated tunneling grasper **150** is inserted through one of the takedown ports **103**, **104**, **105** in a straight position. The distal end of the grasper **165** is inserted behind the pulmonary artery P and the ascending aorta A, and through the transverse sinus TS, as shown in FIG. 27. The multilink articulator **153** is actuated to assume an appropriate curve to pass easily through the transverse sinus TS. Once the distal end of the grasper **165** emerges from the transverse sinus TS on the right side of the heart H, as shown in FIG. 27, the multilink actuator **153** can be used to manipulate the grasper **165** closer to the RIMA. Another grasper may be inserted through another access port to assist with handling the RIMA to the articulated tunneling grasper **150**. The grasper **165** is opened, then closed to grasp the pedicle of the RIMA so as not to damage the vessel. The articulated tunneling grasper **150**, with the RIMA in its grasp, is withdrawn through the transverse sinus TS to the left side of the heart H. The RIMA has thus been tunneled through the transverse sinus TS from the right side of the heart to the left side, as discussed above in relation to FIG. 2.

[0100] Tunneling the RIMA through the transverse sinus TS from the right side of the heart to the left side is the currently preferred path for rerouting the RIMA for attachment to the Cx or the OM branches. Alternatively, the RIMA can be routed across the anterior side of the heart using the articulated tunneler or another thoracoscopic grasping device. When rerouting a graft vessel, particularly when tunneling through a space such as the transverse sinus TS, it is important to avoid twisting or kinking the graft vessel. One way to avoid twisting the vessel is to mark a line along the vessel which can serve as an indicator of whether the vessel is straight. For instance, the vessel can be marked by drawing a line along the vessel or on the pedicle with a surgical marker containing a nontoxic ink, such as methylene blue. The vessel is preferably marked before takedown to assure that the vessel is in a straight condition when it is marked. Alternatively, the clips or sutures that are used to ligate side branches of the vessel during takedown can be used as markers to determine if the graft vessel is straight when it is rerouted.

[0101] FIG. 28 shows a first embodiment of a heart retractor **170** with a finger-like manipulator **171** on the distal end for rotating the heart within the closed chest of the patient to expose each of the coronary arteries to be anastomosed. The retractor **170** has an elongated shaft **172** of approximately 15-30 cm with a handle **173** on the proximal end of the shaft. The distal end of the retractor shaft is curved to create a finger-like manipulator **171**. The curved manipulator **171** has a radius of curvature in one preferred embodiment of approximately 4.5 cm. The radius of curvature in other embodiment can range from 3.5-6 cm. The curvature of the finger-like manipulator **171** subtends an arc of approximately 90 to 180 degrees. The finger-like manipu-

lator **171** has an outer diameter of approximately 5-10 mm. The finger-like manipulator **171** is preferably molded of a rigid plastic, such as ABS or nylon. Alternatively, the finger-like manipulator **171** can be made of metal, such as stainless steel. In one particular alternative embodiment, the finger-like manipulator **171** is made of annealed **316** stainless steel which is malleable so that it can be manually bent to the desired curvature. The exterior of the finger-like manipulator **171** is covered with an absorbent and/or high friction material **174** to assist in grasping and manipulating the heart. The covering **174** of the finger-like manipulator **171** extends to the very distal end **175** of the manipulator **171** and covers the rounded distal tip **175**. The preferred material **174** for covering the finger-like manipulator **171** is a nonwoven polyester fabric, embossed with an open mesh pattern. The nonwoven polyester gives the covering absorbency, while the open mesh pattern improves the friction of the surface. A fabric with a self-sticking adhesive surface is preferred for convenience in assembling the retractor. The currently preferred material for the covering **174** of the finger-like manipulator **171** is a 2.4 oz. nonwoven, embossed polyester medical tape with Wetstick™ adhesive available from Avery Dennison, Specialty Tape Division, Painesville, Ohio.

[0102] Alternate materials for the covering **174** of the finger-like manipulator **171** include nonembossed, nonwoven fabrics, such as polyester surgical felt. While the absorbency of these materials is quite acceptable, the friction of the smooth, nonembossed fabric is less than for embossed materials. Examples of acceptable materials in this category include Fastisorb 820 and Exsorbx 400 available from Berkshire Corp, Great Barrington, Mass. or Surgical Felt 6077 or 6079 available from BARD, Vascular Surgery Division, Haverhill, Mass. Other materials suitable for covering the finger-like manipulator **171** include woven materials and knit materials made of polyester, cotton or other fibers. These materials also tend to have a lower coefficient of friction for gripping tissue. Another alternate material for the covering of the finger-like manipulator **171** is a composite material, including a first layer of a highly absorbent material, like surgical felt, and a second layer of mesh-like material to increasing the coefficient of friction for gripping the surface of the heart.

[0103] The covering material **174** is preferably die cut in a pattern that easily conforms to the shape of the finger-like manipulator **171**. FIG. 30 shows a die-cutting pattern **176** for the covering material **174** to cover a finger-like manipulator **171** having a radius of curvature of 4.5 cm which subtends 180 degrees of arc, and an outer diameter of 8 mm, such as the one shown in FIG. 28. FIG. 30B shows an enlarged detail drawing of the die-cutting pattern **176** of FIG. 30A. The self-adhesive covering material **174** is cut to this pattern **176** and adhesively bonded to the exterior of the finger-like manipulator **171**.

[0104] The absorbency, combined with the texture of the covering **174**, gives the retractor **170** a good frictional grip on the surface of the heart. Keeping the interface between the retractor surface and the surface of the heart dry is important for maintaining a good frictional grip. Another preferred embodiment of the retractor **170**, shown in FIG. 29, combines suction irrigation with the retractor to augment the absorbency of the covering material **174**. In this embodiment, a suction lumen **177** extends through the shaft **172** of

the retractor **170** and through the finger-like manipulator **171**. A series of suction holes **178** connect the suction lumen with the surface of the finger-like manipulator **171** on the inner curve of the distal end. A constant or intermittent suction through the holes **178** will keep the covering material **174** dry to improve the frictional grip on the surface of the heart.

[0105] In use, the retractor **170** is typically inserted into the thoracic cavity through one of the takedown ports **103**, **104**, **105** on the left lateral side of the chest. The curved finger-like manipulator **171** of the retractor **170** is hooked around the apex of the heart H, as shown in **FIG. 31**. The retractor **170** can be used to rotate or translate the position of the heart H within the closed chest. For example, the retractor **170** can be used to roll the heart H toward the right side of the patient to expose the Cx or the OM branches on the left aspect of the heart to the microscope in the visualization port **120**. This position of the heart H is shown in **FIG. 7**. The retractor **170** can also be used to lift the apex of the heart and flip the heart 180 degrees to expose the RCA or PDA on the posterior aspect of the heart H to view. This position of the heart H is shown in **FIG. 9**.

[0106] The retractor **170** can be fixed to the operating table **180** to stabilize the heart H in the desired position, as shown in **FIG. 32**. A positioning device **182**, such as those available from Omni-Tract Surgical Div., Minneapolis, Minn. or Mediflex Medical Products, Islandia, N.Y., is attached to the operating table **180** and bent to the correct position and locked in place. A clamp **181** on the distal end of the positioning device **182** is attached to the proximal end of the retractor **180** to hold it in place and maintain the position of the heart H during the course of the grafting step.

[0107] **FIG. 33A** shows a side view of an embodiment of a suction heart retractor **190** for manipulating the heart within the closed chest of the patient. The retractor **190** has an elongated tubular shaft **191** having a suction cup-shaped manipulator **192** on the distal end. The suction cup-shaped manipulator **192** may be mounted straight on the shaft **191** or it may be mounted at an angle to the shaft **191**. In one particularly preferred embodiment, there is a 45 degree bend **193** near the distal end of the shaft **191** so that the suction cup-shaped manipulator **192** is mounted at a 45 degree angle to the proximal shaft **191**. In either embodiment, the suction cup-shaped manipulator **192** is preferably flexibly mounted to the distal end of the shaft **191**. A vacuum lumen **194** extends through the tubular shaft from the proximal end to the distal end. The distal end of the vacuum lumen **194** is in fluid communication with the interior **195** of the suction cup-shaped manipulator **192**. The proximal end of the vacuum lumen **194** is adapted for attachment to a vacuum source. A fitting for connecting to the vacuum source, such as a barb fitting or luer fitting, may be attached to the proximal end of the tubular shaft **191**, or a flexible extension tube **196** may be attached to the proximal end of the shaft **191** with a fitting at the far end of the extension tube **196**.

[0108] The shaft **191** of the retractor **190** is preferably made of a rigid material that will support the forces required for manipulating the heart without significant deformation. Acceptable materials for the retractor shaft include stainless steel and liquid crystal polymer. To facilitate forming an angled or curved shaft, a mineral filled liquid crystal polymer (e.g. calcium carbonate) is preferred. This material can be heat formed at 350 to 400 degrees F.

[0109] **FIG. 33B** shows a longitudinal cross section of the distal end of the heart retractor **190** of **FIG. 33A**, and **FIG. 33C** shows a distal end view of the heart retractor of **FIG. 33A**. The suction cup-shaped manipulator **192** has an external diameter of approximately 12 to 50 mm for a surface area of approximately 110 to 1960 mm². The surface area of the suction cup-shaped manipulator **192** allows a firm grip on the surface of the heart H when a vacuum is applied to the interior **195** of the suction cup **192**, without causing vacuum damage to the tissue. A valve **197** on the shaft **191** of the retractor **190** allows the surgeon to control the vacuum to turn it on and off. Preferably, the vacuum should be limited to a maximum of 150 mmHg to avoid tissue damage. The suction cup-shaped manipulator **192** is made of a soft, flexible elastomeric material, such as silicone rubber with a hardness of approximately 40 to 80 Shore A durometer. The soft, flexible suction cup-shaped manipulator **192** is designed so that when a vacuum is applied within the interior **195** of the suction cup **192**, the suction cup **192** conforms to the surface of the heart H and does not cause deformation of the heart tissue.

[0110] The distal surface **198** of the suction cup-shaped manipulator **192** is textured to create a high friction surface. In one particularly preferred embodiment, the suction cup-shaped manipulator **192** has a pattern of bumps **199** on the distal surface **198** and a circular ridge **200** around the periphery of the suction cup **192**. The bumps **199** in one preferred embodiment have a height of approximately 1 mm with a 120 degree conical end and straight sides. Other geometries for the friction-increasing bumps **199** include conical, cylindrical or hemispherical, as well as other possible geometries. The circular ridge **200** around the periphery has a height of approximately 1-2 mm. The geometry and the pattern of the bumps **199** create a reliable friction grip on the surface of the heart H under vacuum without causing any damage to the heart tissue. An alternative embodiment of the retractor has an absorbent high friction material (not shown) adhesively attached to or cast into the distal surface of the suction cup-shaped manipulator **192** in place of the pattern of bumps. A suitable absorbent high friction material for this application is a nonwoven polyester fabric embossed with an open mesh pattern.

[0111] In use, the distal end of the retractor **190** is inserted through one of the access ports, typically one of the takedown ports **103**, **104**, **105** in the left lateral side of the patient's chest. The soft, flexible nature of the suction cup-shaped manipulator **192** allows it to be folded or collapsed as it is pushed through the access port. The retractor **190** can be inserted through an access cannula **112** or the cannula **112** can be removed from the access port **103** to facilitate insertion of the suction cup-shaped manipulator **192** directly through the access port **103**. In one preferred embodiment of the method, suction cup-shaped manipulator **192** is placed on the anterior surface of the heart H near the apex, as shown in **FIG. 34**, and a vacuum is applied to grip the surface of the heart. From this position, the retractor **192** can be used to rotate the heart H in either direction. In **FIG. 35**, the retractor **190** has been used to rotate the heart H approximately 90 degrees to the right to expose the Cx and the OM branches on the left aspect of the heart to view. The retractor **190** can also be used to rotate the heart 180 degrees to the left to expose the RCA and PDA on the posterior aspect of the heart, as in **FIG. 8**. In an alternative embodiment of the method, the suction cup-shaped manipulator **192**

is placed on the posterior side of the heart near the apex and a vacuum is applied to grip the surface of the heart. Then, the retractor **190** is used to lift and rotate the heart to flip it 180 degrees to expose the RCA and PDA on the posterior aspect of the heart, as in **FIG. 7**. This retractor **190** can also be fixed to the operating table to stabilize the heart in the desired position similarly to the embodiment of **FIG. 32**.

[0112] **FIG. 36** shows a third retraction device **210** for manipulating the heart within a patient's closed chest. The retraction device **210** has an elongated tubular shaft **211**. The tubular shaft **211** has a right angle bend **212** at the distal end. A first end **213** of a flexible snare **214** is attached to the shaft **211** at the distal end. The second end of the flexible snare extends through a lumen within the tubular shaft **211** and attaches to a sliding handle **215** at the proximal end. The snare **214** is made of a flexible wire or band. Preferably, the flexible wire or band is covered with a soft, flexible friction material to increase the surface area and to improve the frictional grip on the heart. Suitable materials for the covering of the snare include soft, flexible polymers or elastomers or absorbent, high-friction fabrics. The flexible wire or band **214** of the snare is preferably made of a highly resilient material such as a superelastic nickel/titanium alloy or a spring temper stainless steel or titanium alloy.

[0113] **FIG. 37** shows the heart retractor of **FIG. 36** in a predeployed position for insertion through an access cannula. When the sliding handle is in a proximal position, the snare **214'** forms a small loop, as shown in **FIG. 37**, which easily deforms to fit through a 10 mm access cannula. When the sliding handle **215** is in a distal position, the snare **215** forms a large loop **214**, as shown in **FIG. 36**, which is large enough to encircle the heart H. The wire is preferably preshaped so that the snare opens up in a loop **214** perpendicular to the axis of the distal segment **216** of the shaft **211**. **FIG. 38** shows a cross section of a patient showing the retraction device **210** inserted into the thoracic cavity through one of the access ports **103** with the snare encircling the heart H. From this position, the retractor **210** can be used to manipulate the heart H to a desired position. For example, the retractor **210** can be used to lift and rotate the heart H to flip it 180 degrees to expose the RCA and PDA on the posterior aspect of the heart, as in **FIG. 7**.

[0114] **FIG. 39** shows a fourth retractor device **220** for manipulating the heart within the close chest of a patient in a predeployed position for insertion through an access cannula. The retractor **220** has an elongated tubular shaft **221** with a handle **226** on the proximal end. In a preferred embodiment, the distal end **222** of the shaft has an angled portion at an approximately 0 to 45 degree angle to the proximal portion of the shaft **221**. A flexible band **223** extends through a lumen within the tubular shaft **221** and extends beyond the distal end of the shaft **221**. The distal end of the band **223** is pivotally attached to a distal link **224**. The distal link **224** is, in turn, pivotally attached to a proximal link **225** which, in turn, is pivotally attached to the distal end **222** of the tubular shaft **221**. The proximal end of the band **223** is attached to a sliding actuator button **227** on the handle **226**. When the activator button **227** is in a proximal position, the distal portion of the flexible band **223** is positioned parallel to and in close proximity to be proximal **225** and distal links **224**, as shown in **FIG. 39**. When the activator button **227** is in a distal position, the distal portion of the flexible band **223** extends from the distal end of the tubular

shaft **221** to form a loop **228** together with the proximal **225** and distal links **224**, as shown in **FIG. 40**. In the illustrative embodiment of **FIGS. 39 and 40**, the handle **226** has a semicircular cassette **229** for storage of the band **223** when the band is in the proximal position. Other embodiments of the retractor **220** could have a circular storage cassette or a linear configuration for storing the retracted band **221**. Preferably, the flexible band **223** is made of a resilient material such as a spring tempered stainless steel or titanium alloy. The proximal **225** and distal links **224** are also preferably made of a stainless steel or titanium alloy. The surfaces of the flexible band **223** and/or the proximal **225** and distal links **224** facing the inside of the loop **229** are preferably covered with a soft, flexible friction material to improve the frictional grip a the retractor on the heart H. Suitable materials for the covering of the loop **228** include soft, flexible polymers or elastomers or absorbent, high-friction fabrics.

[0115] In use, the distal end of the retractor loop **220** is inserted into the thoracic cavity through one of the access ports **103**, typically one of the takedown ports **103, 104, 105** on the left lateral side of the chest. The actuator button **227** is advanced distally to open the loop **228** large enough to encircle the heart H. The loop **22** is passed around the heart H from the apex end and tightened gently around the heart, as shown in **FIG. 41**. A force limiter can be incorporated into the actuating mechanism of the retractor **220** to prevent excessive force on the heart H. From this position, the retractor **220** can be used to manipulate the heart H to a desired position. For example, the retractor **220** can be used to lift and rotate the heart to flip it 180 degrees to expose the RCA and PDA on the posterior aspect of the heart, as in **FIG. 7**.

[0116] **FIGS. 42-45** show a topical hypothermia device **230** which can be used to improve myocardial protection during the port-access multivessel CABG procedure. The topical hypothermia device **230** has a flexible heat exchanger **231** which has at least one fluid passage **232** therethrough to circulate a cooling fluid. The flexible heat exchanger **231** is collapsible to a predeployed position which can easily fit through an access port into the chest of the patient. The flexible heat exchanger **231** is attached to the distal end of an elongated tubular shaft **233**. The tubular shaft **233** is preferably made of a rigid material such as stainless steel or a rigid plastic. An inflow lumen **234** extends through the tubular shaft **233** and is fluidly connected to the flexible heat exchanger **231**. A return lumen **235** extends through the tubular shaft **233** parallel to the inflow lumen **234**. The inflow lumen **234** and the return lumen **235** may be formed of extruded plastic tubes which are inserted through the tubular shaft **233**. Alternatively, the lumens **234, 235** may be formed integrally with the tubular shaft **233** by extrusion. The proximal ends of the inflow lumen **234** and the return lumen **235** are adapted for attachment to a circulating pump **236** and a reservoir of cooling fluid **237**, which is preferably a saline solution.

[0117] In the illustrative embodiment of **FIG. 42**, the flexible heat exchanger **231** is made from two sheets of flexible plastic which are heat sealed or RF sealed together to form a serpentine cooling path **232** through the heat exchanger **231**. Preferred materials for manufacturing the flexible heat exchanger **231** include polyurethane, vinyl, polypropylene, nylon, etc. The flexible heat exchanger **231**,

in one preferred embodiment, has a length of 12-18 cm and a width of 7-10 cm. Optionally, the flexible heat exchanger **231** may have a flexible backbone **238** which extends from the distal end of the tubular shaft **233** to the distal edge of the heat exchanger **231**. The flexible backbone **238** may be made from a flexible polymer, elastomer, or a resilient metal wire, such as spring temper stainless steel or a superelastic nickel/titanium alloy, or a composite of metal and plastic. The flexible heat exchanger **231** is rolled, folded or twisted and placed in an introducer sheath **239** in the predeployed position as shown in **FIG. 43**. Preferably, the introducer sheath **239** is sized to fit through an access cannula with a 10-12 mm internal diameter.

[**0118**] In use, the topical hypothermia device **230** is prepared in the predeployed position by first priming the flexible heat exchanger **231** by filling it with cooling fluid and connecting the proximal end of the inflow lumen **234** and the return lumen **235** to the circulating pump **236** and the reservoir of cooling fluid **237**. The flexible heat exchanger **231** is rolled and covered with the introducer sheath **239**. The topical hypothermia device **230** is inserted through one of the access ports **104** in this predeployed position. The distal end of the introducer sheath **239** is placed under the heart **H** and then withdrawn proximally with respect to the flexible heat exchanger **231**, thereby placing the flexible heat exchanger **231** underneath the heart **H**. Alternatively, the sheath **239** can be withdrawn after the topical hypothermia device **230** is introduced through the access port **104** and the flexible heat exchanger **231** placed under the heart **H** with the help of the flexible backbone **238**. The circulating pump **236** is turned on to force cooling fluid into the flexible heat exchanger **231** and through the cooling passage **232**. The flexible heat exchanger **231** inflates with cooling fluid and spreads out under the heart **H** to make good thermal contact with the myocardium, as shown in **FIG. 45**. Preferably, the flexible heat exchanger **231** is constructed so that it curves to conform to the exterior of the heart **H** when inflated to the deployed position, as shown in **FIG. 44**, to create a better thermal contact with the myocardium. Typically, a cooling fluid at 0-4 degrees Celcius is circulated through the flexible heat exchanger **231** with a flow rate of greater than 350 ml/min to rapidly cool the heart.

[**0119**] In an alternate embodiment of the topical cooling device, the flexible heat exchanger **231** may also be covered with a thermal insulating material, such as surgical felt, to prevent thermal shock to the myocardial tissue. Another way to avoid thermal shock to the myocardial tissue is to use a more moderate temperature for the cooling fluid, with better thermal contact and a higher flow rate to rapidly cool the myocardium without the risk of thermal shock.

[**0120**] **FIG. 46** shows an alternate embodiment of the topical cooling device **240**, which is similar to the embodiment of **FIG. 42** except for the construction of the flexible heat exchanger **241**. In this embodiment, the flexible heat exchanger is in the form of a ring made by heat sealing two sheets of plastic together. The cooling fluid enters one side of the ring-shaped heat exchanger and follows a serpentine cooling path **242** through the heat exchanger **241** around to the other side of the ring. A preformed, resilient wire loop **248** is attached around the outside of the ring-shaped heat exchanger **241** to initialize the shape of the heat exchanger **241** during deployment, as shown in **FIG. 47**.

[**0121**] The topical cooling device **230, 240** can be used alone to induce hypothermic cardiac arrest in the patient's heart or the topical cooling device **230, 240** can be used in conjunction with cardioplegic arrest to improve the myocardial protection during the surgical procedure. In addition, the topical cooling device **230, 240** can be used to rewarm the heart after the completion of the surgical procedure by circulating warm fluid through the flexible heat exchanger **231, 241**. In addition to the multivessel CABG procedure of the present invention, the topical cooling device **230, 240** will find utility for improving myocardial protection in any open-chest or closed-chest cardiac surgery.

[**0122**] Another closely related surgical approach for performing closed-chest multivessel CABG surgery is through an anterior mediastinotomy, that is, through an incision into the mediastinum, the mass of tissues and organs between the lungs that includes the heart. Another term for this surgical approach is a rib-sparing, anterior mini-thoracotomy. There are two ways to perform the anterior mediastinotomy for this approach. The first way is through an intercostal incision **250, 25-50 mm** long, in the fourth **I4** or fifth **I5** intercostal space to the left of the sternum **S**, as shown in **FIG. 48**. The second way is to create a larger access port **260** by removing either the third **C3**, fourth **C4** or fifth **C5** costal cartilage, preferably on the left side of the sternum **S**. When one of the costal cartilages is removed it creates an access port **260** approximately 50-60 mm square, as shown in **FIG. 49**. The access port **260** can be held open using a tissue spreader for an access cannula which is oval or square in shape. Actual cutting or removal of ribs is not necessary. The best position for the port may be decided by viewing through the lateral **IMA** takedown ports in the third or fourth intercostal space and probing with a needle to find the best position and line of sight for the particular anastomosis site. It should be noted that, because the anterior mediastinotomy may cut across the path of the internal mammary artery, it is preferable to make the access port after completion of the **IMA** takedown.

[**0123**] A tissue spreader or oval cannula **251** for retraction would be useful to maintain the access channel. Retraction of the ribs should be kept to a minimum in order to reduce the trauma to the patient. For introduction without retraction of the ribs, the oval cannula **251** should have interior dimensions of approximately 12 mm width and 25-50 mm length, and a thin wall of approximately 1 mm thick. For varying degrees of retraction, the width of the oval cannula **251** can be increased anywhere from 12 mm to 25 mm, which should be sufficient for adequate visualization and instrument access. Visualization and instrument insertion can thus be accomplished through a single elongated access port, rather than using separate visualization and instrument ports as in the port-access approach described above. Visualization can be accomplished using a surgical microscope, as described above, or by direct visualization through the access port **250, 260**, with or without magnifying loupes. The cannula **251** should be configured to facilitate retraction of the pedicle through the lumen of the cannula without harm so that the distal end of the graft vessel can be prepared for anastomosis outside of the body under direct visualization. Therefore, the cannula **251** should have no sharp edges that could harm the graft vessel or pedicle. The insertion length of the cannula **251** should be about 25-50 mm.

[**0124**] Preferably, illumination means are incorporated into the oval cannula **251** or into the tissue spreader used to

maintain the access channel. A light conduction path is incorporated into the wall of the oval cannula **251** or into the blades of the tissue spreader to direct a beam of light distally onto the surgical site. A light source is connected to the light conduction path. The light source can be integrated into the device or an external light source may be connected to the device by an optical cable.

[**0125**] An exemplary embodiment of an illuminated access device is shown in a top view in **FIG. 50** and a side view in **FIG. 51**. This particular embodiment is an illuminated oval cannula **251**, however the following inventive features can also be incorporated into a blade retractor, tissue spreader, or standard circular access cannula. Optical fibers **252** are embedded into the wall of the oval cannula **251**. The optical fibers terminate at the distal end of the cannula **251** to direct a beam of light distally toward the surgical site. A narrow or diffuse beam of light can be created depending on the arrangement and the numerical aperture of the optical fibers. At the proximal end of the cannula **251**, the optical fibers **252** gather together into an optical connector **253** for connection to an external light source. In one currently preferred embodiment, a multiplicity of small diameter optical fibers are distributed evenly about the periphery of the oval cannula **251**. The wall of the oval cannula **251** can be made of an opaque material to avoid light escaping from the optical fibers **252** from interfering with visualization through the lumen **254** of the cannula **251**. Alternatively, the interior and/or exterior wall of the cannula **251** can be made transparent or translucent to create a diffuse ambient light within or around the cannula **251**.

[**0126**] Anastomosis between the graft vessel and the coronary artery is performed using instruments inserted through the access port **250**, **260**. One advantage of this approach is that the access port **250**, **260** is large enough so that the surgeon can insert a finger through the access port or oval cannula **251** to directly palpate the heart, for instance to locate a stenosis in the coronary artery. It may be advantageous to elevate the heart within the thoracic cavity to facilitate palpation of the heart and/or performing the anastomosis. A device similar to the topical cooling devices **230**, **240** of **FIGS. 42-47** may be used to elevate the heart **H** within the thoracic cavity by inserting it underneath the heart and inflating it, with or without circulating cooling fluid. The tunneling and retraction devices of **FIGS. 22-41** can be used through the access port or through the takedown ports to manipulate the heart to expose different aspects of the heart for visualization and anastomosis of multiple coronary arteries according to the methods described above. Alternatively, a second mediastinal access port **250'**, **260'** can be opened on the right side of the chest to access the right coronary artery directly. In another alternative approach, a right side mediastinal access port **250'**, **260'** may be used alone if only the right coronary artery is to be revascularized or if the patient's anatomy favors a right side approach for multivessel revascularization.

What is claimed is:

1. A method of cardiac surgery on a heart within a chest of a patient, the chest having a sternum and a plurality of ribs, each rib being separated from an adjacent rib by an intercostal space, the method comprising the steps of:

making at least one access port into the chest through an intercostal space, a first aspect of the heart facing the

access port, and a second aspect of the heart facing away from the access port;

introducing a retraction instrument through the access port; and

manipulating the retraction instrument to reposition the heart within the chest into a retracted position wherein the second aspect of the heart is facing the access port;

wherein the ribs and sternum remain intact during each of said steps.

2. The method of claim 1 wherein the access port is made in a left lateral portion of the chest and wherein the first aspect of the heart comprises a left lateral aspect.

3. The method of claim 2 wherein the second aspect of the heart comprises an aspect of the heart selected from a posterior aspect, a right lateral aspect, and an anterior aspect.

4. The method of claim 1, further comprising the step of:

visualizing the heart with a visualization instrument introduced into the chest of the patient through a second access port positioned within an intercostal space.

5. The method of claim 1, further comprising the step of:

anastomosing a vascular graft onto a coronary artery on the heart while the heart is in the retracted position.

6. The method of claim 5, wherein the anastomosing step comprises the substep of introducing an anastomosing instrument into the chest of the patient through an access port within an intercostal space.

7. The method of claim 5, wherein the anastomosing step comprises anastomosing the vascular graft onto a circumflex artery.

8. The method of claim 5, wherein the anastomosing step comprises anastomosing the vascular graft onto a right coronary artery.

9. The method of claim 5 wherein the anastomosing step comprises anastomosing the vascular graft onto a posterior descending coronary artery.

10. The method of claim 5, wherein the vascular graft is selected from the group including a left internal mammary artery, a right internal mammary artery, a gastroepiploic artery, a radial artery, a saphenous vein, and a prosthetic vascular graft.

11. The method of claim 5 further comprising the step of:

dissecting an internal mammary artery from an anterior wall of the patient's chest;

and wherein the anastomosing step comprises anastomosing the internal mammary artery onto the coronary artery.

12. The method of claim 5, further comprising the step of:

anastomosing a second vascular graft onto a second coronary artery using an anastomosing instrument introduced through an access port within an intercostal space.

13. The method of claim 12 wherein the second vascular graft is selected from the group including a left internal mammary artery, a right internal mammary artery, a gastroepiploic artery, a radial artery, a saphenous vein, and a prosthetic vascular graft.

14. The method of claim 13 wherein the second coronary artery comprises a left anterior descending coronary artery.

15. The method of claim 13 wherein the second coronary artery comprises a circumflex artery.

16. The method of claim 13 wherein the second coronary artery comprises a right coronary artery.

17. The method of claim 12 further comprising repositioning the heart into a second retracted position using said retraction instrument before the step of anastomosing a second vascular graft.

18. The method of claim 1 wherein the manipulating step comprises the substep of applying a vacuum between a surface of the retraction instrument and a surface of the heart to grip the heart with the retraction instrument.

19. The method of claim 1 wherein the manipulating step comprises the substep of lifting the heart with a rigid finger on the retraction instrument.

20. The method of claim 1 wherein the manipulating step comprises the substeps of placing a flexible loop on the retraction instrument around the heart and tightening the loop.

21. The method of claim 1 wherein the manipulating step comprises rotating the heart.

22. The method of claim 21 wherein the heart is rotated about an axis extending longitudinally through the heart from an aortic root generally toward an apex of the heart.

23. The method of claim 21 wherein the heart is rotated about an axis disposed at an acute angle between 0° and 90° relative to a longitudinal axis extending from an aortic root toward an apex of the heart.

24. The method of claim 1, further comprising the step of:

partitioning an ascending aorta of the patient, paralyzing the heart, and maintaining circulation of oxygenated blood in the patient.

25. The method of claim 24 wherein the partitioning step comprises the substep of introducing an intraluminal occlusion device into a peripheral artery of the patient, transluminally advancing the intraluminal occlusion device into the ascending aorta and occluding the ascending aorta between the patient's coronary ostia and brachiocephalic artery.

26. The method of claim 1 wherein the introducing step comprises the substeps of inserting the retraction instrument through the access port in a predeployed state and deploying the retraction instrument into a deployed state within the chest of the patient.

27. The method of claim 26 wherein the retraction instrument has a profile in the predeployed state which is smaller than its profile in the deployed state.

28. The method of claim 27 wherein the profile in the predeployed state has a diameter of less than about 12 mm.

29. A method of retracting a heart within a chest of a patient, the chest having a sternum and a plurality of ribs, each rib being separated from an adjacent rib by an intercostal space, the method comprising the steps of:

making at least one access port into the chest through an intercostal space;

introducing a retraction instrument through the access port;

applying a vacuum between a surface of the retraction instrument and a surface of the heart to grip the heart with the retraction instrument; and

manipulating the retraction instrument to reposition the heart within the chest of the patient;

wherein the ribs and sternum remain intact during each of said steps.

30. The method of claim 29 wherein the step of applying a vacuum comprises applying a vacuum through a suction cup attached to the retraction instrument.

31. The method of claim 29 wherein the step of manipulating comprises engaging the surface of the heart with a textured surface on the retraction instrument to reduce slippage of the retraction instrument on the surface of the heart.

32. The method of claim 29 wherein the access port is positioned so that a first aspect of the heart is facing the access port, and a second aspect of the heart is facing away from the access port, the step of manipulating comprising repositioning the heart so that the second aspect of the heart is facing the access port.

33. The method of claim 32 wherein the access port is positioned in a left lateral side of the patient's chest, the first aspect of the heart comprising a left lateral aspect of the heart.

34. The method of claim 33 wherein the heart is repositioned so that an anterior aspect of the heart is facing the access port.

35. The method of claim 33 wherein the heart is repositioned so that a posterior aspect of the heart is facing the access port.

36. The method of claim 33 further comprising performing a surgical procedure on a third aspect of the heart through a second access port positioned within an intercostal space.

37. The method of claim 35 wherein the surgical procedure comprises anastomosing a vascular graft to a coronary artery on the third aspect of the heart.

38. The method of claim 36 wherein the coronary artery is selected from the group including the right coronary artery, posterior descending artery, the left anterior descending coronary artery, and the circumflex artery.

39. The method of claim 36 wherein the vascular graft is selected from the group including an internal mammary artery, a gastroepiploic artery, a radial artery, a saphenous vein, and a prosthetic vascular graft.

40. The method of claim 36 wherein the second access port is disposed in an anterior side of the patient's chest.

41. The method of claim 29 wherein the step of manipulating comprises rotating the heart about a longitudinal axis extending from an aortic root generally toward an apex of the heart.

42. The method of claim 29 wherein the introducing step comprises the substeps of inserting the retraction instrument through the access port in a predeployed state and deploying the retraction instrument into a deployed state within the chest of the patient.

43. The method of claim 42 wherein the retraction instrument has a profile in the predeployed state which is smaller than its profile in the deployed state.

44. The method of claim 43 wherein the profile in the predeployed state has a diameter of less than about 12 mm.

45. A method of cardiac surgery on a heart within a chest of a patient, the chest having a sternum and a plurality of ribs, each rib being separated from an adjacent rib by an intercostal space, the method comprising the steps of:

making at least one access port into the chest through an intercostal space;

introducing a myocardial cooling device through the access port; and

cooling the patient's heart using the myocardial cooling device;

wherein the ribs and sternum remain intact during each of said steps.

46. The method of claim 45 wherein the introducing step comprises the substeps of inserting the myocardial cooling device through the access port in a predeployed state and deploying the myocardial cooling device into a deployed state within the chest of the patient.

47. The method of claim 46 wherein the myocardial cooling device has a profile in the predeployed state which is smaller than its profile in the deployed state.

48. The method of claim 47 wherein the profile in the deployed state has a diameter of less than about 12 mm.

49. The method of claim 46 wherein the deploying step comprises the substep of inflating the myocardial cooling device with a cooling fluid.

50. The method of claim 46 wherein the deploying step comprises the substep of extending the myocardial cooling device from within a sheath.

51. The method of claim 45 wherein the cooling step comprises the substep of positioning the myocardial cooling device in thermal contact with the patient's heart.

52. The method of claim 45 wherein the cooling step comprises the substep of circulating a cooling fluid through the myocardial cooling device.

53. The method of claim 45, further comprising the step of:

anastomosing a vascular graft onto a coronary artery on the patient's heart using an anastomosing instrument introduced through an access port within an intercostal space.

54. The method of claim 45, further comprising the step of:

introducing a retraction instrument into the patient's chest through an access port within an intercostal space; and

manipulating the retraction instrument to reposition the heart within the patient's chest.

55. A method of performing coronary artery bypass graft surgery at a surgical site on a heart within a chest of a patient, the chest having a sternum and a plurality of ribs, each rib being separated from an adjacent rib by an intercostal space, the method comprising the steps of:

making first and second access ports into the chest through at least one intercostal space, the surgical site being on an aspect of the heart facing away from the first access port;

introducing a retraction instrument through the second access port;

manipulating the retraction instrument to reposition the heart within the chest into a retracted position wherein the aspect of the heart containing the surgical site is facing the first access port; and

anastomosing a vascular graft to a coronary artery at the surgical site using an anastomosing instrument introduced through the first access port;

wherein the ribs and sternum remain intact during each of said steps.

56. The method of claim 55 wherein the second access port is made in a left lateral portion of the chest.

57. The method of claim 55 wherein the first access port is made in an anterior portion of the chest.

58. The method of claim 57 wherein the aspect of the heart is selected from the group including a posterior aspect, a right lateral aspect, and a left lateral aspect.

59. The method of claim 55, further comprising the step of:

visualizing the heart with a visualization instrument introduced into the chest of the patient through a third access port positioned within an intercostal space.

60. The method of claim 55 wherein the anastomosing step comprises anastomosing the vascular graft onto a circumflex artery.

61. The method of claim 55, wherein the anastomosing step comprises anastomosing the vascular graft onto a right coronary artery.

62. The method of claim 55 wherein the anastomosing step comprises anastomosing the vascular graft onto a posterior descending coronary artery.

63. The method of claim 55, wherein the vascular graft is selected from the group including a left internal mammary artery, a right internal mammary artery, a gastroepiploic artery, a radial artery, a saphenous vein, and a prosthetic vascular graft.

64. The method of claim 55 further comprising the step of:

dissecting an internal mammary artery from an anterior wall of the patient's chest;

and wherein the anastomosing step comprises anastomosing the internal mammary artery onto the coronary artery.

65. The method of claim 64 wherein the step of dissecting comprises dissecting the right internal mammary artery from an anterior wall of the chest using a dissection instrument introduced through an access port in an intercostal space in a right lateral portion of the chest.

66. The method of claim 64 further comprising routing the right internal mammary into a left portion of the chest using a grasping instrument introduced through an access port in an intercostal space.

67. The method of claim 66 wherein the right internal mammary artery is routed through a transverse epicardial sinus of the patient into the left portion of the chest.

68. The method of claim 67 wherein the grasping instrument is introduced through an access port in a left lateral portion of the chest, further comprising tunneling the grasping instrument through the transverse epicardial sinus into a right portion of the chest before the step of routing.

69. The method of claim 55, further comprising the step of:

anastomosing the vascular graft onto a second coronary artery using an anastomosing instrument introduced through an access port within an intercostal space.

70. The method of claim 69, wherein the first anastomosing step comprises creating a side-to-side anastomosis between the vascular graft and the coronary artery and the second anastomosing step comprises creating an end-to-side anastomosis between the vascular graft and the second coronary artery.

71. The method of claim 55, further comprising the step of:

anastomosing a second vascular graft onto a second coronary artery using an anastomosing instrument introduced through an access port within an intercostal space.

72. The method of claim 84 wherein the second vascular graft is selected from the group including a left internal mammary artery, a right internal mammary artery, a gastroepiploic artery, a radial artery, a saphenous vein, and a prosthetic vascular graft.

73. The method of claim 71 wherein the second coronary artery is selected from the group including a left anterior descending coronary artery, a circumflex artery, a right coronary artery, and a posterior descending coronary artery.

74. The method of claim 71, further comprising the step of:

anastomosing the second vascular graft onto a third coronary artery.

75. The method of claim 74, wherein the second anastomosing step comprises creating a side-to-side anastomosis between the second vascular graft and the second coronary artery and the third anastomosing step comprises creating an end-to-side anastomosis between the second vascular graft and the third coronary artery.

76. The method of claim 55 wherein the manipulating step comprises the substep of applying a vacuum between a surface of the retraction instrument and a surface of the heart to grip the heart with the retraction instrument.

77. The method of claim 55 wherein the manipulating step comprises the substep of lifting the heart with a rigid finger on the retraction instrument.

78. The method of claim 55 wherein the manipulating step comprises the substeps of placing a flexible loop on the retraction instrument around the heart and tightening the loop.

79. The method of claim 55 wherein the manipulating step comprises rotating the heart.

80. The method of claim 79 wherein the heart is rotated about an axis extending longitudinally through the heart from an aortic root generally toward an apex of the heart.

81. The method of claim 79 wherein the heart is rotated about an axis disposed at an angle between 0° and 90° relative to a longitudinal axis extending from an aortic root toward an apex of the heart.

82. The method of claim 55, further comprising the step of:

cooling the patient's heart with a myocardial cooling device inserted into the chest of the patient through an access port in an intercostal space.

83. The method of claim 55, further comprising the step of:

partitioning an ascending aorta of the patient, paralyzing the heart, and maintaining circulation of oxygenated blood in the patient.

84. The method of claim 83 wherein the partitioning step comprises the substep of introducing an intraluminal occlusion device into a peripheral artery of the patient, transluminally advancing the intraluminal occlusion device into the ascending aorta and occluding the ascending aorta between the patient's coronary ostia and brachiocephalic artery.

85. The method of claim 55 wherein the introducing step comprises the substeps of inserting the retraction instrument

through the access port in a predeployed state and deploying the retraction instrument into a deployed state within the chest of the patient.

86. The method of claim 85 wherein the retraction instrument has a profile in the predeployed state which is smaller than its profile in the deployed state.

87. The method of claim 86 wherein the profile in the predeployed state has a diameter of less than about 12 mm.

88. The method of claim 55 wherein the step of anastomosing comprises forming an opening in the coronary artery with a cutting instrument introduced through an access port in an intercostal space, and attaching the vascular graft to the coronary artery around the opening.

89. The method of claim 88 wherein the step of attaching comprises suturing the vascular graft to the coronary artery using a suturing instrument introduced through an access port in an intercostal space.

90. The method of claim 88 wherein the step of attaching comprises introducing a suture into the chest of the patient through an access port in an intercostal space and suturing the vascular graft to the coronary artery with the suture.

91. The method of claim 90 wherein the suture has a first end and a second end, a first needle attached to said first end and a second needle attached to said second end, said suture having a length of about 8 to 10 centimeters, and wherein the step of attaching comprises tying the suture within the chest of the patient using a suturing instrument introduced through an access port in an intercostal space.

92. The method of claim 55 further comprising the step of dissecting a gastroepiploic artery within an abdomen of the patient to create a free end thereof, and routing the free end into the chest, the step of anastomosing comprising anastomosing the free end to the coronary artery.

93. The method of claim 92 wherein the step of dissecting comprises dissecting the gastroepiploic artery using a dissection instrument introduced into the abdomen an access cannula positioned in a wall of the abdomen.

94. The method of claim 93 wherein the step of dissecting further comprises visualizing the interior of the abdomen using a scope introduced through an access cannula into the abdomen.

95. The method of claim 92 wherein the step of routing comprises creating an opening in a diaphragm of the patient between the abdomen and the chest, and introducing the free end of the gastroepiploic artery through the opening into the chest.

96. A myocardial cooling device comprising:

a shaft having a proximal end, a distal end, and at least a first lumen therebetween; and

an inflatable bladder attached to the distal end of the shaft and having at least one cooling passage therethrough in communication with the first lumen, said inflatable bladder having a predeployed state and a deployed state, wherein said inflatable bladder is insertable through an access port in an intercostal space when in said predeployed state.

97. The myocardial cooling device of claim 96 wherein said inflatable bladder is insertable through a cannula having an internal diameter of 12 millimeters when in said predeployed state.

98. The myocardial cooling device of claim 96 further comprising a sheath which covers said inflatable bladder when in said predeployed state.

99. The myocardial cooling device of claim 98 wherein said inflatable bladder is extended from said sheath when in said deployed state.

100. The myocardial cooling device of claim 96 wherein said inflatable bladder is inflated with a cooling fluid when in said deployed state.

101. The myocardial cooling device of claim 96 further comprising a means for circulating a cooling fluid through said at least one cooling passage.

102. The myocardial cooling device of claim 115 wherein the shaft further comprises a second lumen in communication with an outlet of said at least one cooling passage, whereby the cooling fluid may be delivered through the first lumen into the cooling passage, circulated therethrough, and received through the second lumen.

103. The myocardial cooling device of claim 96 wherein the at least one cooling passage comprises a plurality of horizontal passages interconnected by a series of vertical passages.

104. The myocardial cooling device of claim 96 wherein the inflatable bladder has a curvature in the deployed state selected to conform to an exterior surface of the heart.

105. The myocardial cooling device of claim 98 wherein the inflatable bladder is configured to twist into a helical configuration when contained within the sheath in the undeployed state.

106. A surgical retraction device comprising:

a shaft having a proximal end and a distal end;

a contact surface adjacent said distal end for atraumatically contacting living tissue within a body cavity; and

a means for applying a vacuum at said contact surface.

107. The surgical retraction device of claim 106 wherein said means for applying a vacuum at said contact surface comprises a passage from said proximal end to said distal end of said shaft, said passage being in fluid communication with said contact surface.

108. The surgical retraction device of claim 106 wherein said contact surface further comprises a friction-increasing surface.

109. The surgical retraction device of claim 106 wherein said contact surface is flexibly mounted to said distal end of said shaft.

110. The surgical retraction device of claim 106 wherein said contact surface is mounted at an angle of approximately 45 degrees to a longitudinal axis of said shaft.

111. The surgical retraction device of claim 108 wherein said friction-increasing surface comprises a multiplicity of bumps extending from said contact surface.

112. The surgical retraction device of claim 106 wherein said contact surface is concave.

113. The surgical retraction device of claim 110 wherein said contact surface is disposed on a distal side of a cup-shaped member attached to said distal end of said shaft.

114. The surgical retraction device of claim 111 wherein said cup-shaped member is flexible.

115. The surgical retraction device of claim 112 wherein said cup-shaped member is sufficiently flexible to conform to a surface of a patient's heart when a vacuum is applied between said contact surface and the surface of the heart.

116. The surgical retraction device of claim 113 wherein said contact surface further comprises a friction-increasing surface.

117. The surgical retraction device of claim 116 wherein said friction-increasing surface comprises a multiplicity of bumps extending from said contact surface.

118. The surgical retraction device of claim 106 wherein said shaft and contact surface are configured to be positioned through an access port in an intercostal space.

119. The surgical retraction device of claim 118 wherein access port has a diameter of 12 mm.

120. The surgical retraction device of claim 118 wherein the contact surface is on a contact member attached to the distal end of the shaft, contact surface being larger than the access port in an unstressed condition, the contact member being collapsible so as to be positionable through the access port.

121. A surgical retraction device for retracting a body structure within a body cavity, the body structure having a curved external surface, the surgical retraction device comprising:

a rigid shaft having a distal end and a proximal end, the shaft having a contact surface near the distal end with a curvature selected to conform to the external surface of the body structure; and

a textured, porous material attached to the contact surface for frictionally engaging the body structure;

wherein a distal portion of the shaft including the contact surface and porous material may be introduced into the body cavity through an access port with a diameter of at most about 12 mm.

122. The surgical retraction device of claim 121 wherein the porous material comprises a fabric pad.

123. The surgical retraction device of claim 121 wherein the porous material comprises surgical gauze.

124. The surgical retraction device of claim 121 wherein the porous material comprises a foam pad.

125. The surgical retraction device of claim 121 wherein the porous material is wrapped around a distal portion of the shaft.

126. The surgical retraction device of claim 121 wherein the contact surface comprises a lateral surface of a distal portion of the shaft, the distal portion of the shaft having a diameter of less than about 10 mm.

127. The surgical retraction device of claim 121 wherein the porous material covers the distal end of the shaft.

128. The surgical retraction device of claim 121 further comprising an aspiration lumen within the shaft extending from the proximal end to at least the contact surface, and a plurality of holes in the contact surface in communication with the lumen, whereby a vacuum may be applied through the aspiration lumen and the holes to withdraw fluids from the porous material.

129. The surgical retraction device of claim 121 wherein at least a portion of the shaft is malleable such that the contact surface may be shaped into various curvatures.

130. A surgical retraction device for retracting a body structure within a body cavity, the retractor comprising:

a rigid shaft having a proximal end and a distal end;

a guide means along the shaft; and

a flexible band extending through the guide means so as to be slidable with respect to the shaft, the flexible band forming a loop at the distal end of the shaft and having a first end attached to the shaft and a second end

extending to the proximal end of the shaft, whereby the size of the loop may be enlarged or reduced by sliding the band relative to the shaft;

wherein a distal portion of the shaft and the loop may be introduced through an access port with a diameter of at most 12 mm.

131. The surgical retraction device of claim 130 wherein the band has a rectangular cross-section.

132. The surgical retraction device of claim 130 wherein the band is metal.

134. The surgical retraction device of claim 130 wherein the loop has a friction-increasing inner surface for engaging the body structure.

135. The surgical retraction device of claim 134 wherein the friction increasing inner surface comprises a porous material attached to the band.

136. The surgical retraction device of claim 130 wherein the loop is formed around an axis which is generally perpendicular to a longitudinal axis of the shaft.

137. The surgical retraction device of claim 130 wherein the loop is formed around an axis parallel to a longitudinal axis of the shaft.

138. The surgical retraction device of claim 130 wherein the band is a superelastic alloy.

139. The surgical retraction device of claim 130 wherein the band is a shape-memory alloy.

140. The surgical retraction device of claim 130 further comprising a link pivotably coupled to the distal end of the shaft, the first end of the band being attached to the link.

141. The surgical retraction device of claim 140 wherein the link is jointed so as to have a proximal section and a distal section pivotably attached to the proximal section, the proximal section being pivotably attached to the shaft, and the distal section being attached to the first end of the band.

142. The surgical retraction device of claim 130 wherein the guide means comprises a lumen in the shaft, the band being disposed slidably within the lumen.

143. The surgical retraction device of claim 130 further comprising actuation means at the proximal end of the shaft for sliding the band relative to the shaft.

144. A surgical tunneling instrument for tunneling between adjacent body structures in a body cavity, the tunneling instrument comprising:

a shaft having a distal end, a proximal end and a lumen therebetween;

a linkage extending through the lumen;

an articulating finger at the end of the shaft, the articulating finger comprising:

a first proximal member having a proximal end and a distal end opposite the proximal end, the proximal end being pivotably coupled to the shaft at a first point and coupled to the linkage at a second point laterally offset from the first point;

a second proximal member having a proximal end pivotably coupled to the shaft and a distal end opposite the proximal end; and

a distal member having a proximal end and a distal end opposite the proximal end, the distal end being configured for tunneling between the body structures, and the proximal end being pivotably coupled to the distal end of the first proximal member at a third point and pivotably coupled to the distal end of the second proximal member at a fourth point laterally offset from the third point; and

means at the proximal end of the shaft for moving the linkage relative to the shaft, whereby the first proximal member pivots relative to the shaft about the first point and the distal member pivots relative to the first proximal member about the third point.

145. The tunneling instrument of claim 144 further comprising means at the distal end of the distal member for grasping a vascular structure.

146. The tunneling instrument of claim 145 wherein the grasping means comprises a hook.

147. The tunneling instrument of claim 145 wherein the grasping means comprises a snare.

148. The tunneling instrument of claim 145 wherein the grasping means comprises a pair of grasping jaws, at least one of said grasping jaws being movable with respect to the other.

149. The tunneling instrument of claim 145 wherein the first and second points are separated by a first transverse distance, and the third and fourth points are separated by a second transverse distance, the first and second transverse distances being less than about 10 mm.

* * * * *

专利名称(译)	用于端口进入多支血管冠状动脉搭桥手术的装置和方法		
公开(公告)号	US20020092533A1	公开(公告)日	2002-07-18
申请号	US09/982502	申请日	2001-10-19
[标]申请(专利权)人(译)	BOYD STEPHENW 拉帕茨基ALAN - [R 沃什卡MATTHIAS 唐隆BRIAN小号 PETERS威廉二世		
申请(专利权)人(译)	博伊德史蒂芬W. 拉帕茨基ALAN R. 沃什卡MATTHIAS 唐隆BRIAN S. PETERS威廉S.		
当前申请(专利权)人(译)	BOYD STEPHENW 拉帕茨基ALAN - [R 沃什卡MATTHIAS 唐隆BRIAN小号 PETERS威廉二世		
[标]发明人	BOYD STEPHEN W RAPACKI ALAN R VASKA MATTHIAS DONLON BRIAN S PETERS WILLIAM S		
发明人	BOYD, STEPHEN W. RAPACKI, ALAN R. VASKA, MATTHIAS DONLON, BRIAN S. PETERS, WILLIAM S.		
IPC分类号	A61B17/00 A61B17/02 A61B17/04 A61B17/28 A61B17/30 A61B17/34 A61B18/14 A61B19/00 A61F2/24 A61F2/958 A61F7/00 A61F7/10 A61M1/00		
CPC分类号	A61B17/00234 A61B17/0218 A61B17/29 A61B17/2909 A61B18/1492 A61B19/52 A61B2017/00243 A61B2017/00247 A61B2017/0225 A61B2017/0237 A61B2017/0243 A61B2017/047 A61B2017/0472 A61B2017/2912 A61B2017/2927 A61B2017/2932 A61B2017/306 A61B2017/308 A61B2017/3405 A61B2017/3492 A61B2018/00214 A61B2018/00232 A61B2018/00261 A61B2018/00291 A61B2018/00363 A61B2018/00392 A61B2018/00577 A61B2019/5206 A61F2/2427 A61F7/10 A61F2007/0001 A61F2007/0054 A61F2007/101 A61M25/1011 A61M39/0247 A61M2025/028 A61M2039/0279 A61M2205/3344 A61M2205/3355 A61M2205/366 A61B90/36 A61B2090/306		
优先权	09/019014 1998-02-05 US		
其他公开文献	US7017581		
外部链接	Espacenet USPTO		

摘要(译)

公开了用于在多支冠状动脉疾病中执行端口进入或闭胸冠状动脉旁路 (CABG) 手术的手术方法和器械。与需要正中胸骨切开术或其他大体胸廓切开术以暴露患者心脏的标准开胸CABG手术相比, 通过小切口或通过患者肋骨之间的肋间隙制成的进出口进行端口接入CABG手术, 从而导致大大减轻了患者的疼痛和发病率。通过胸腔镜或腹腔镜移除技术准备用于移植的原位动脉旁路移植植物,

例如内乳动脉和/或右胃网膜动脉。可以使用自由移植体，例如隐静脉移植体或自由动脉移植体增加原位动脉移植体。通过插入肋间入口的心脏显微镜直接观察，移植血管与冠状动脉吻合。提供回缩器械以操纵患者的闭合胸腔内的的心脏以暴露每个冠状动脉以进行可视化和吻合。公开了一种用于重新布置移植管的隧道器和铰接式隧道式抓紧器，以及用于操纵心脏的指状牵开器，吸盘牵开器，圈套器牵开器和环牵引器。还公开了一种端口接入局部冷却装置，用于在端口接入CABG手术期间改善心肌保护。使用前纵隔切开术的另一种手术方法也是描述。

