



US009661986B2

(12) **United States Patent**  
**Shahmoon et al.**

(10) **Patent No.:** **US 9,661,986 B2**  
(45) **Date of Patent:** **May 30, 2017**

(54) **MULTICORE FIBER ENDOSCOPES**

2011/0137126 A1\* 6/2011 French ..... A61B 1/00165  
600/178

(71) Applicant: **Z Square Ltd.**, Tel Aviv (IL)

2011/0301414 A1\* 12/2011 Hotto ..... A61B 1/00009  
600/114

(72) Inventors: **Asaf Shahmoon**, Petah-Tikva (IL);  
**Alex Zlotnik**, Ashdod (IL); **Zeev**  
**Zalevsky**, Rosh Ha Ayin (IL); **Sigal**  
**Kremer-Tal**, Ramat-Hasharon (IL);  
**David Zigdon**, Tel Aviv (IL)

2013/0156389 A1\* 6/2013 Shinji ..... A61B 1/00167  
385/103

2013/0278740 A1 10/2013 Zalevsky et al.

(Continued)

(73) Assignee: **Z Square Ltd.**, Tel Aviv (IL)

FOREIGN PATENT DOCUMENTS

(\* ) Notice: Subject to any disclaimer, the term of this  
patent is extended or adjusted under 35  
U.S.C. 154(b) by 58 days.

EP 1918743 5/2008

OTHER PUBLICATIONS

(21) Appl. No.: **14/805,915**

Fortin et al., Evaluation of the microscanning process, 1994, 9  
pages.\*

(22) Filed: **Jul. 22, 2015**

(Continued)

(65) **Prior Publication Data**

US 2016/0022119 A1 Jan. 28, 2016

**Related U.S. Application Data**

*Primary Examiner* — Timothy J Neal

(60) Provisional application No. 62/028,346, filed on Jul.  
24, 2014, provisional application No. 62/119,832,  
filed on Feb. 24, 2015.

(74) *Attorney, Agent, or Firm* — Pearl Cohen Zedek;  
Latzter Baratz LLP

(51) **Int. Cl.**

**A61B 1/06** (2006.01)

**A61B 1/00** (2006.01)

(Continued)

(57) **ABSTRACT**

(52) **U.S. Cl.**

CPC ..... **A61B 1/00117** (2013.01); **A61B 1/0017**  
(2013.01); **A61B 1/00096** (2013.01);

(Continued)

Endoscopes, multicore endoscope fibers and configuration  
and operation methods are provided. The fibers may have  
hundreds or thousands of cores and possibly incorporate  
working channel(s) and additional fibers. The fiber may be  
used at different optical configurations to capture images of  
tissue and objects at the distal tip and to enhance a wide  
range of optical characteristics of the images such as reso-  
lution, field of view, depth of field, wavelength ranges etc.  
Near-field imaging as well as far-field imaging may be  
implemented in the endoscopes and the respective optical  
features may be utilized to optimize imaging. Optical ele-  
ments may be used at the distal fiber tip, or the distal fiber  
tip may be lens-less. Diagnostics and optical treatment  
feedback loops may be implemented and illumination may  
be adapted to yield full color images, depth estimation,  
enhanced field of views and/or depths of field, and additional  
diagnostic data.

(58) **Field of Classification Search**

CPC ..... A61B 1/00163; A61B 1/00165; A61B  
1/00167; A61B 1/0017; A61B 1/00172;

(Continued)

(56) **References Cited**

U.S. PATENT DOCUMENTS

7,738,180 B2\* 6/2010 Igarashi ..... G02B 23/243

348/45

2008/0033301 A1\* 2/2008 DellaVecchia ..... A61B 3/12

600/477

2008/0107386 A1\* 5/2008 Kudou ..... G02B 6/02042

385/126

2009/0137893 A1\* 5/2009 Seibel ..... A61B 1/0005

600/407

**21 Claims, 13 Drawing Sheets**

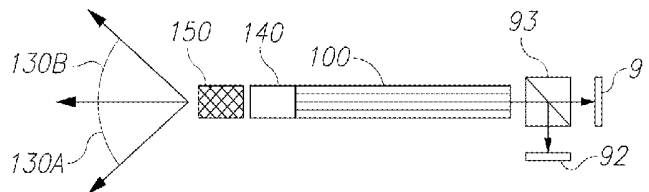

(51) **Int. Cl.**

*A61B 1/07* (2006.01)  
*G02B 23/26* (2006.01)  
*G02B 6/04* (2006.01)  
*G02B 6/02* (2006.01)

(52) **U.S. Cl.**

CPC ..... *A61B 1/00167* (2013.01); *A61B 1/00174*  
(2013.01); *A61B 1/00193* (2013.01); *A61B*  
*1/0676* (2013.01); *A61B 1/07* (2013.01); *G02B*  
*23/26* (2013.01); *G02B 6/02042* (2013.01);  
*G02B 6/04* (2013.01)

(58) **Field of Classification Search**

CPC ..... A61B 1/00174; A61B 1/00193; A61B  
1/0676  
USPC ..... 600/182  
See application file for complete search history.

(56)

**References Cited**

U.S. PATENT DOCUMENTS

2015/0208144 A1\* 7/2015 Holmes ..... H04J 14/02  
398/48

OTHER PUBLICATIONS

International Search Report of International Application No. PCT/  
IL2015/050756 mailed Nov. 5, 2015.

\* cited by examiner

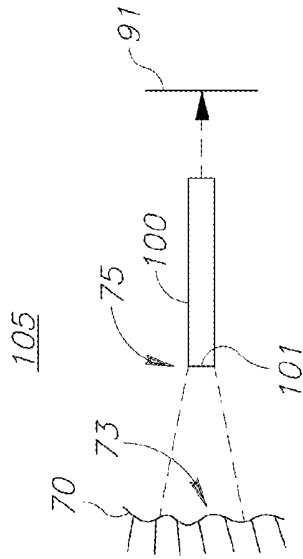

Figure 1A

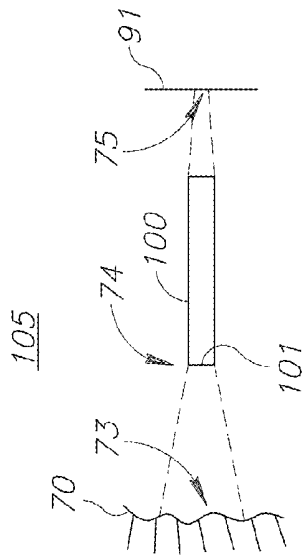

Figure 1B

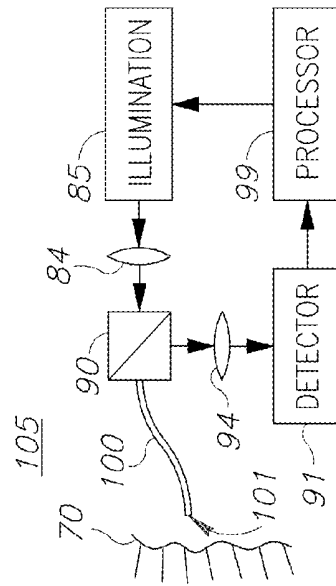

Figure 1C

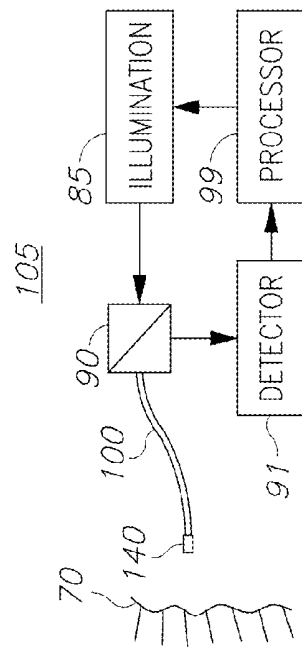

Figure 1D

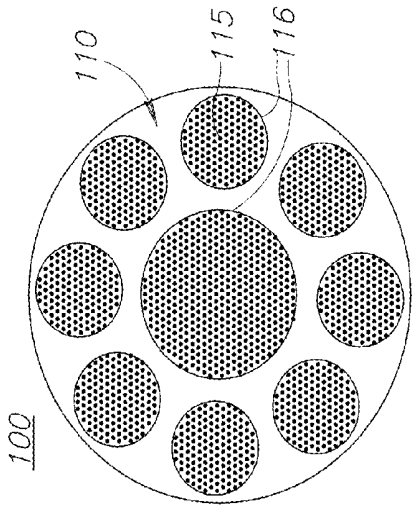

Figure 2C

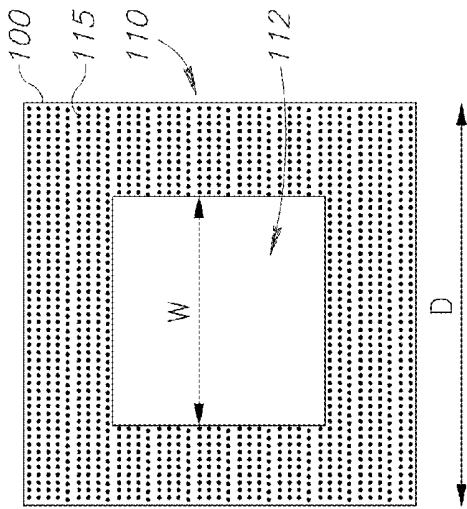

Figure 2B

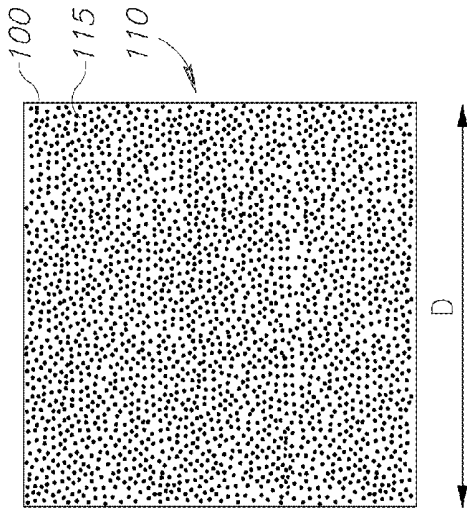

Figure 2A

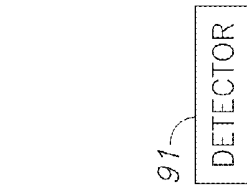

Figure 2E

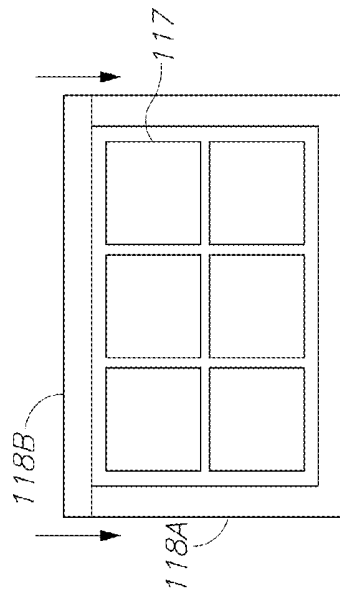
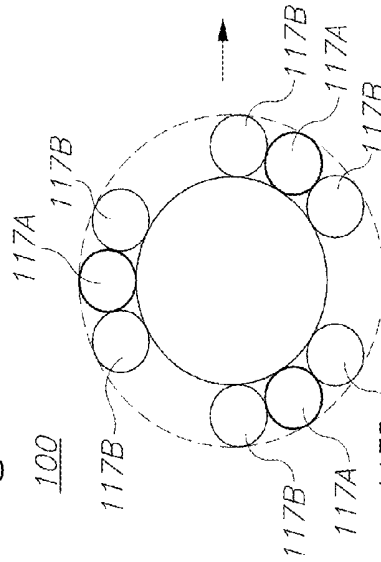
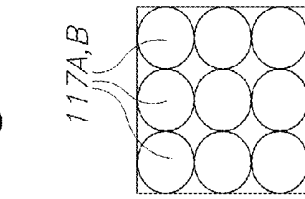

Figure 2D

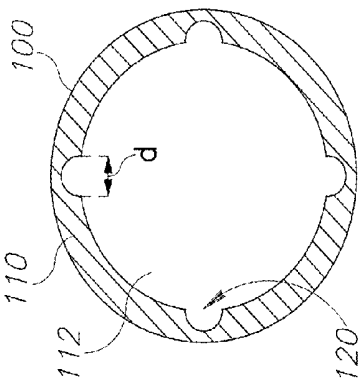

Figure 3A

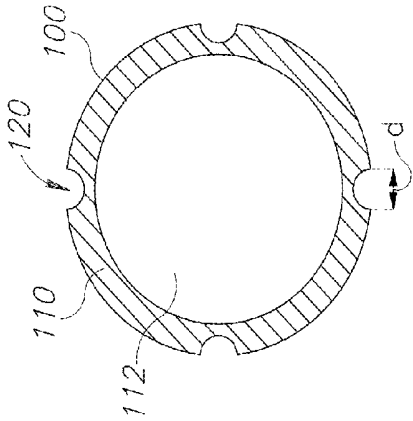

Figure 3B

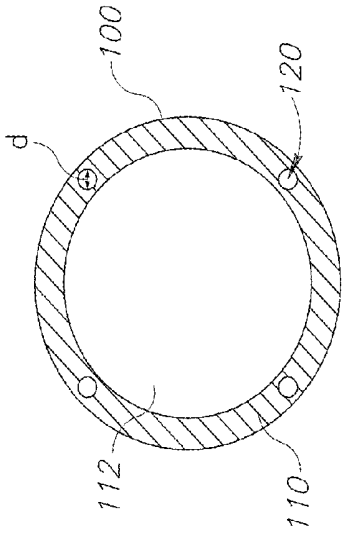

Figure 3C

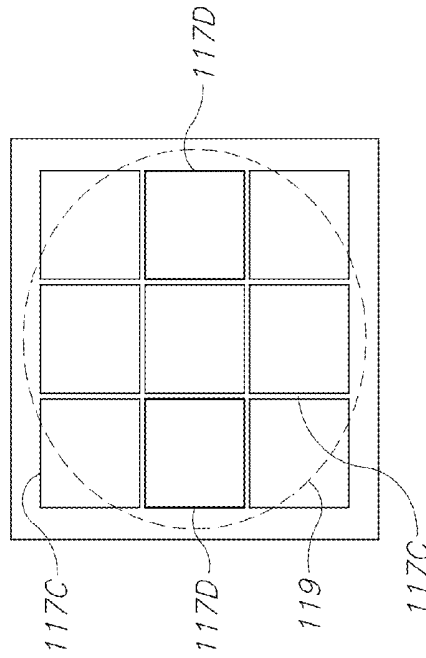

Figure 3D

100

117C

117D

119

117C

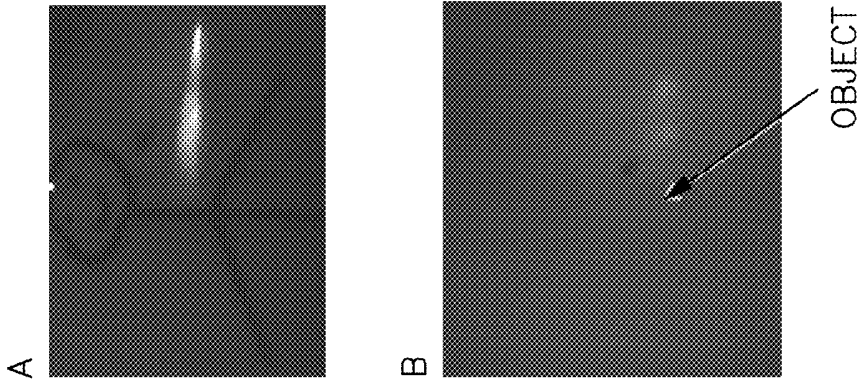

Figure 3F

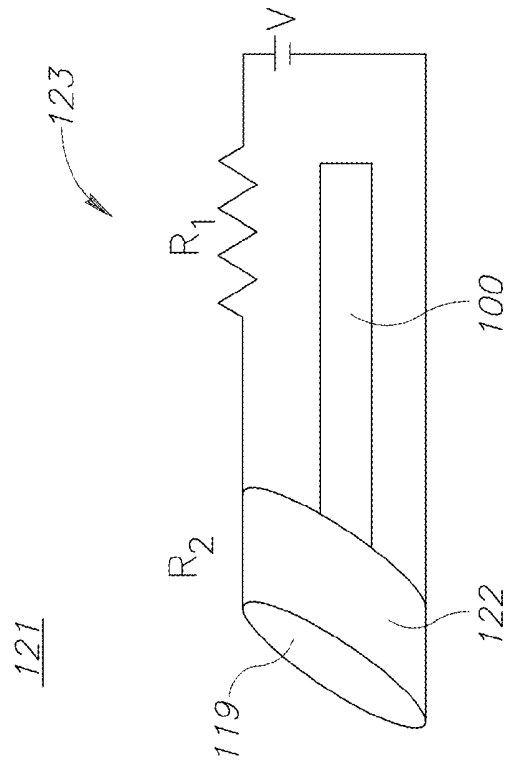

Figure 3E

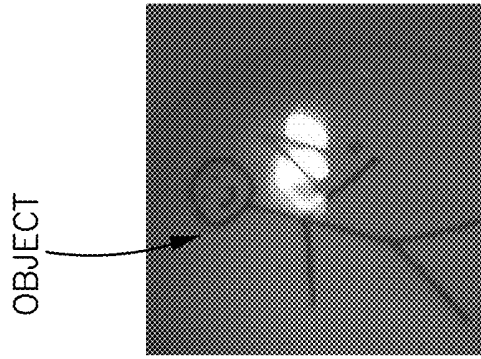

Figure 3G

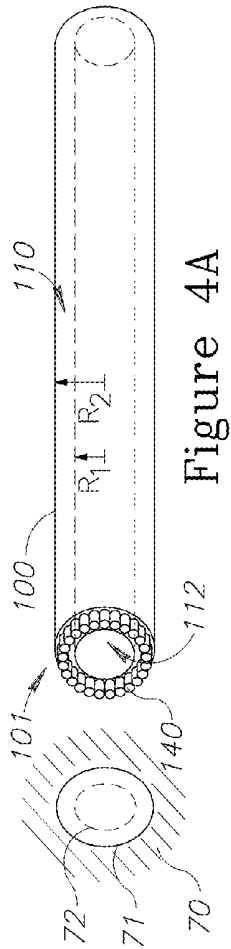

Figure 4A

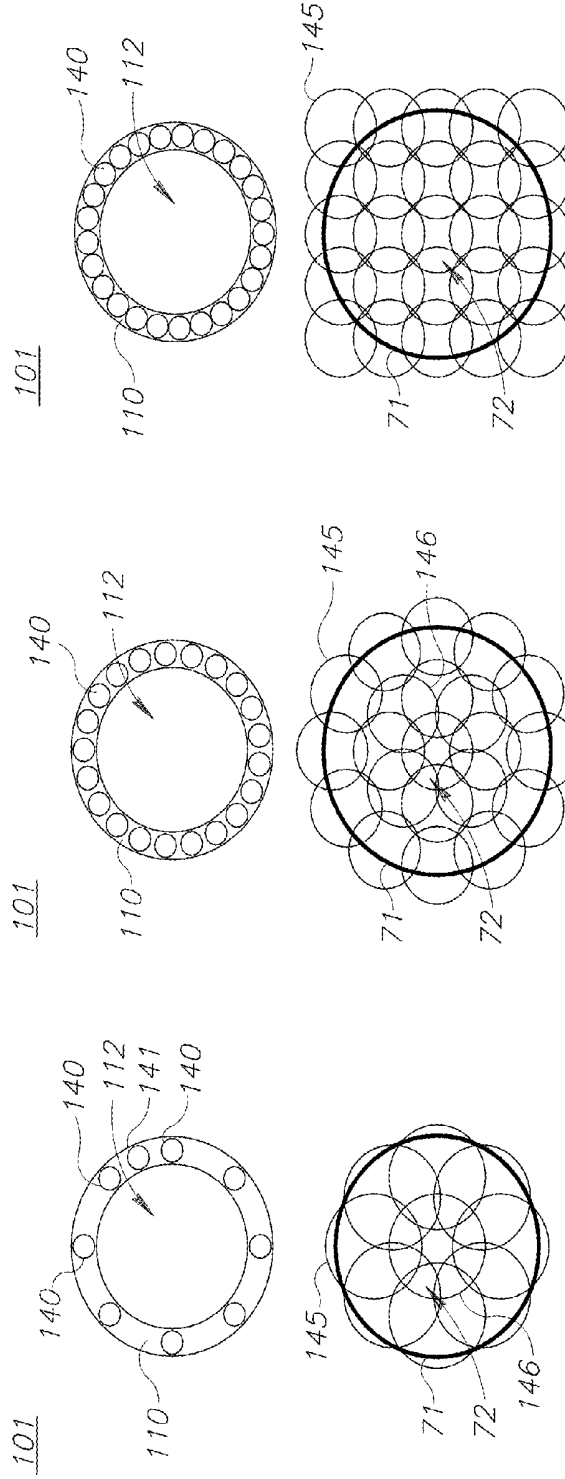

Figure 4B

Figure 4C

Figure 4D

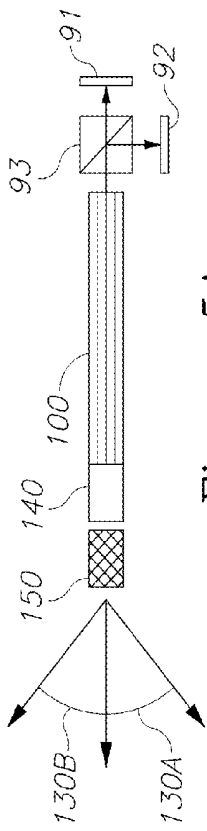

Figure 5A

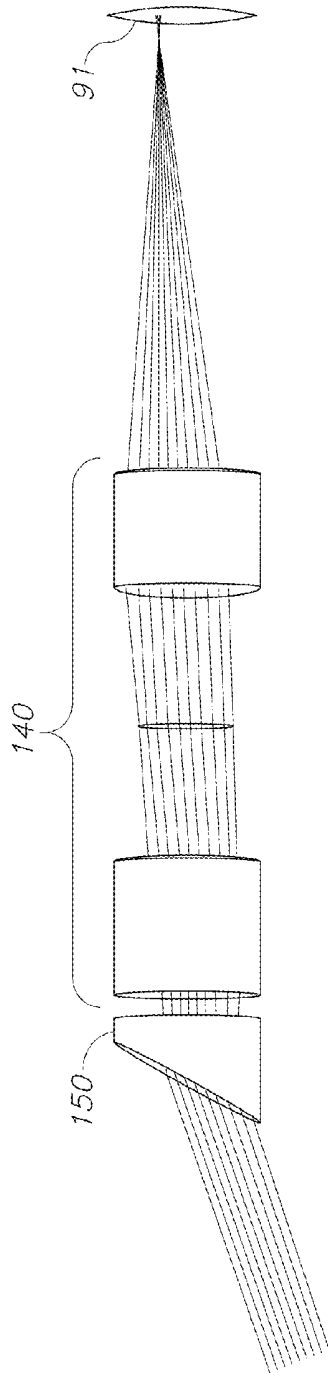

Figure 5B

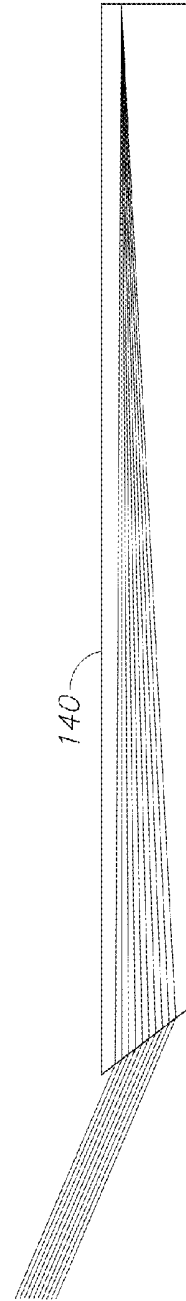

Figure 5C

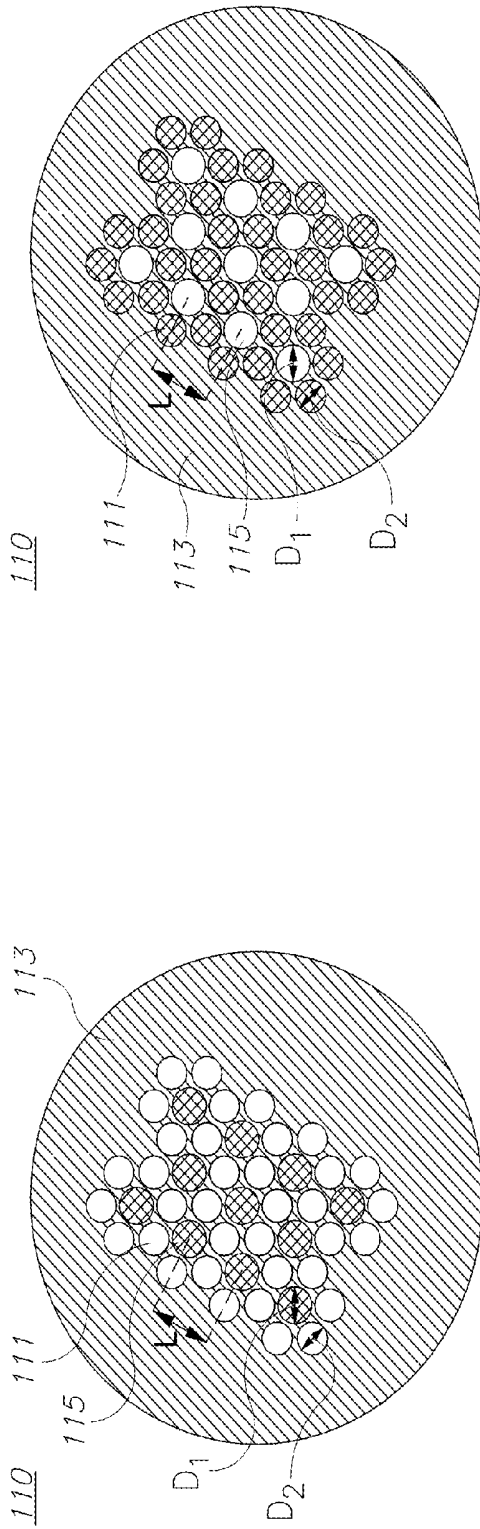

Figure 6B

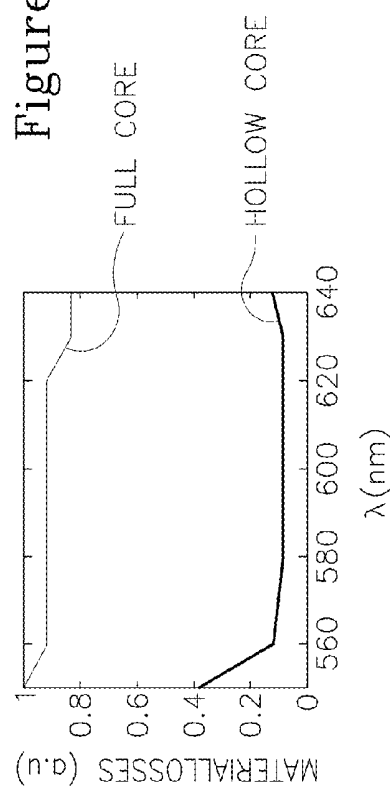

Figure 6A

Figure 6C

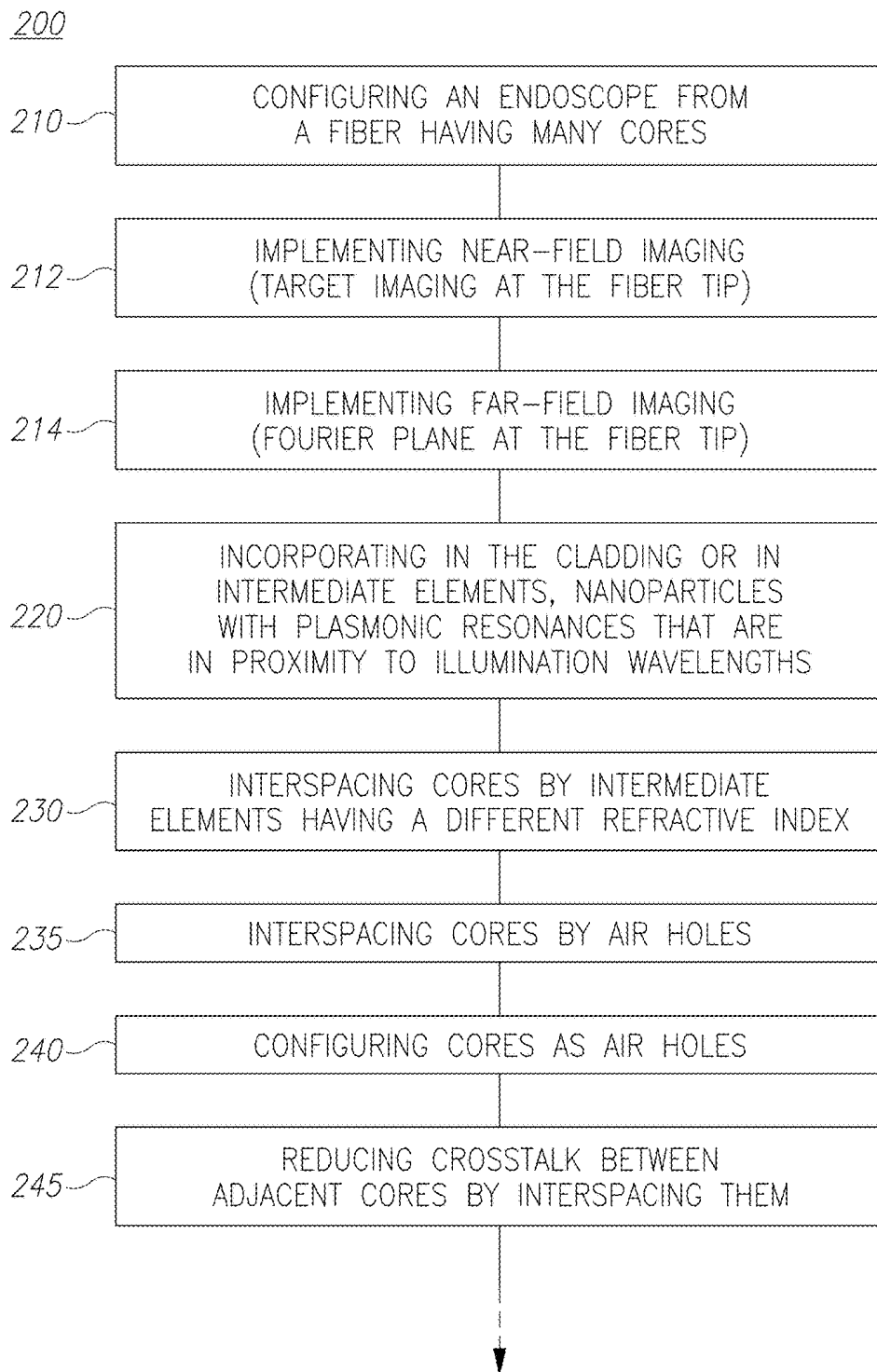

Figure 7

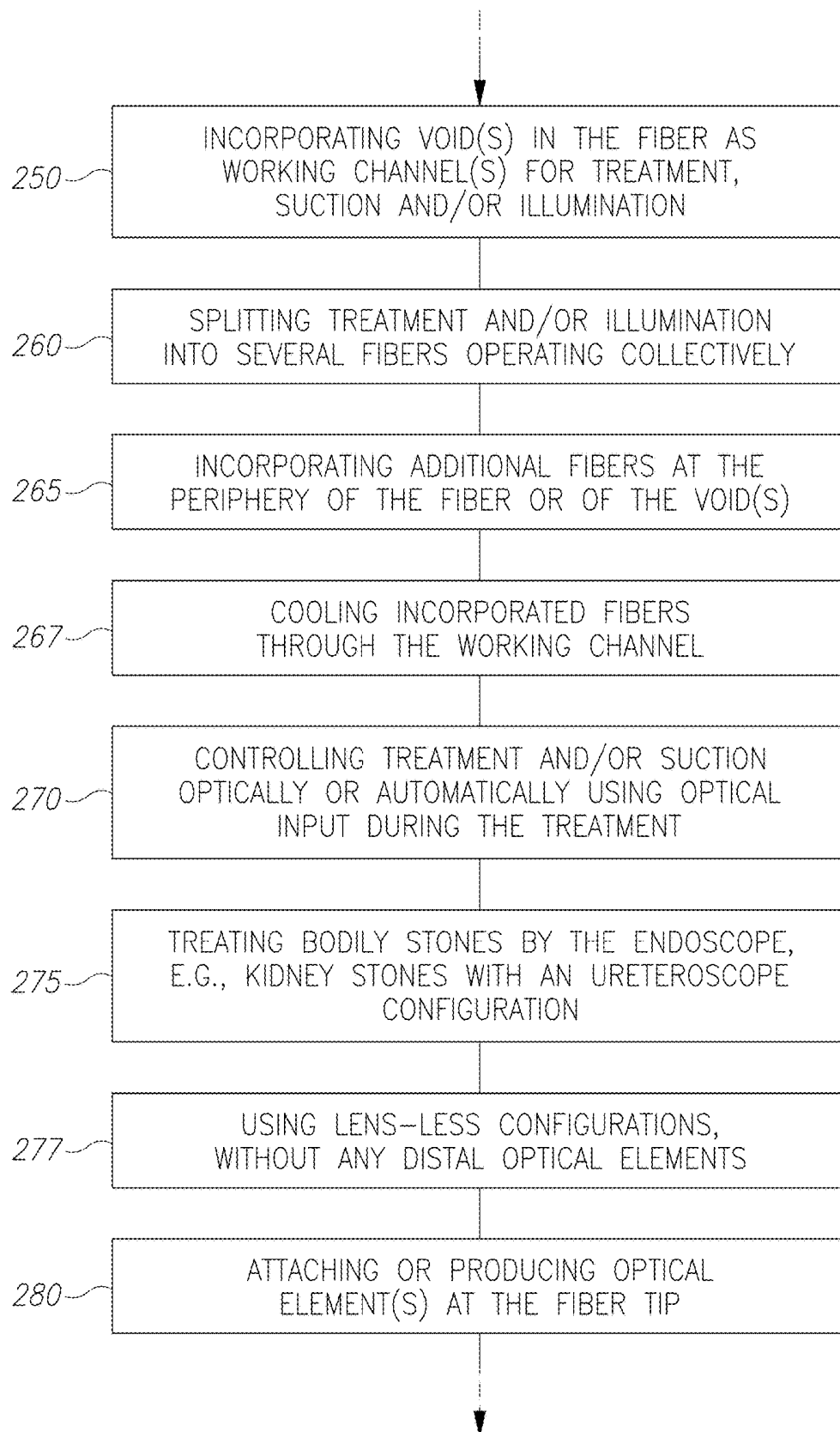

Figure 7 (cont. 1)

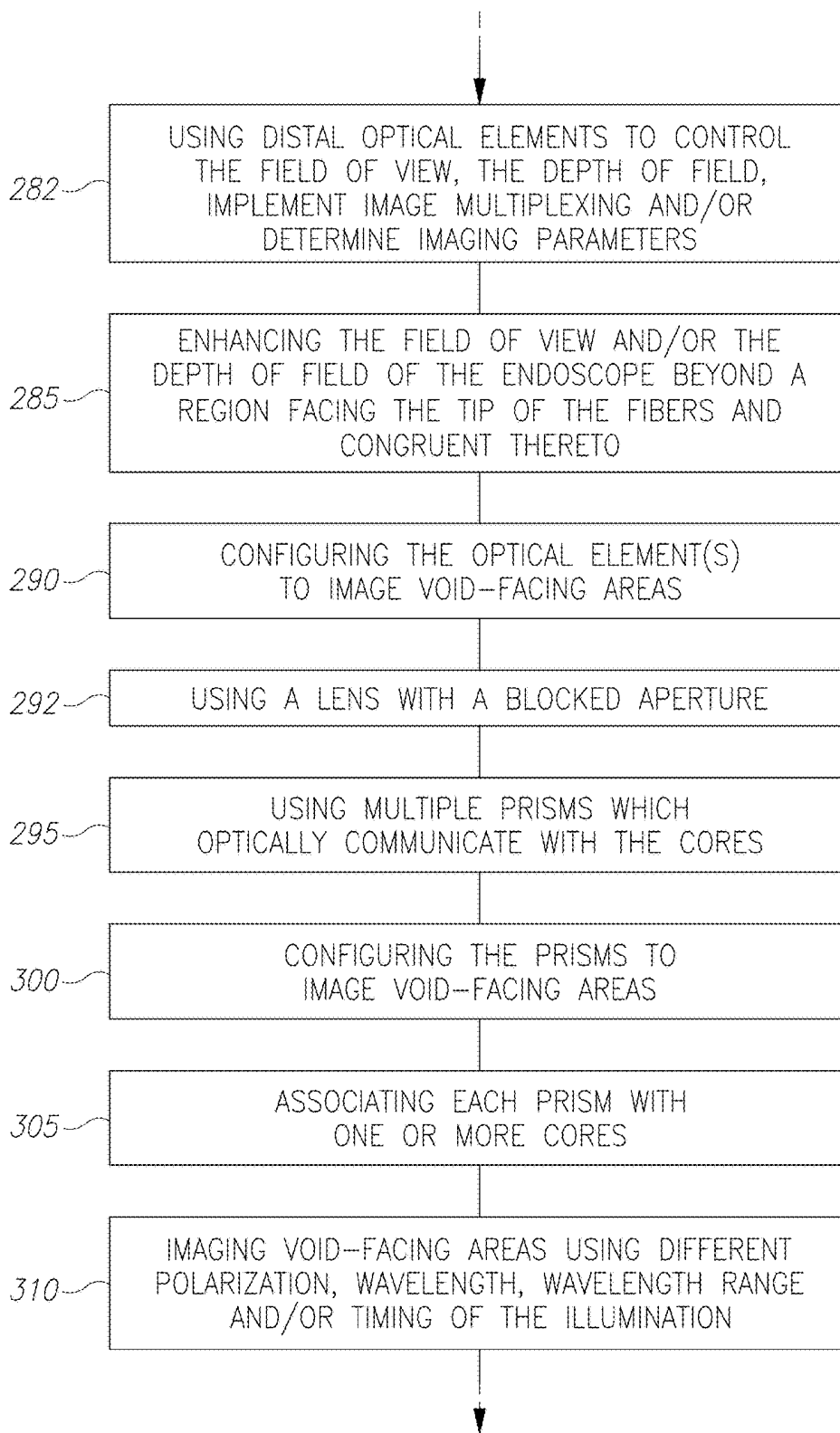

Figure 7 (cont. 2)

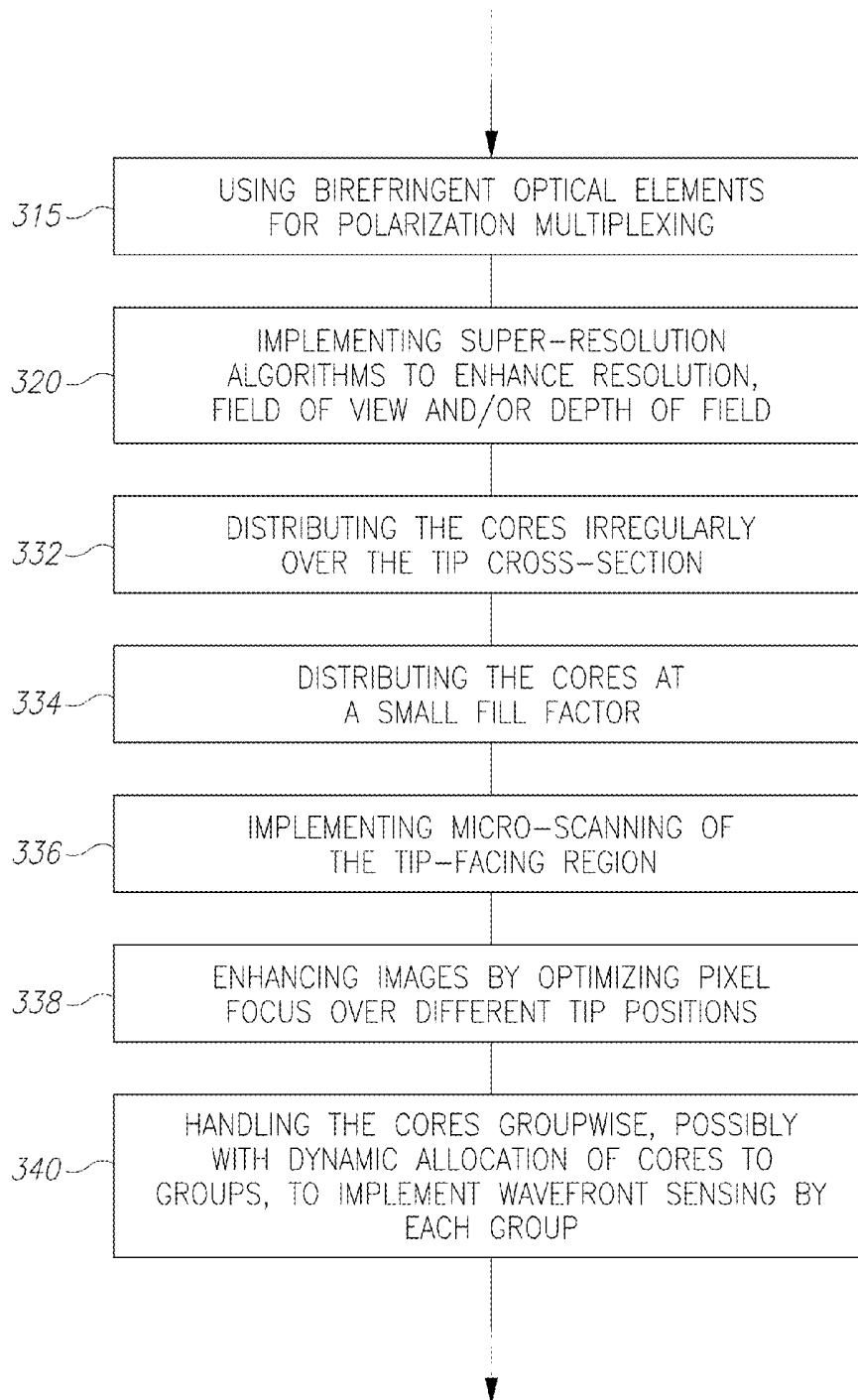

Figure 7 (cont. 3)

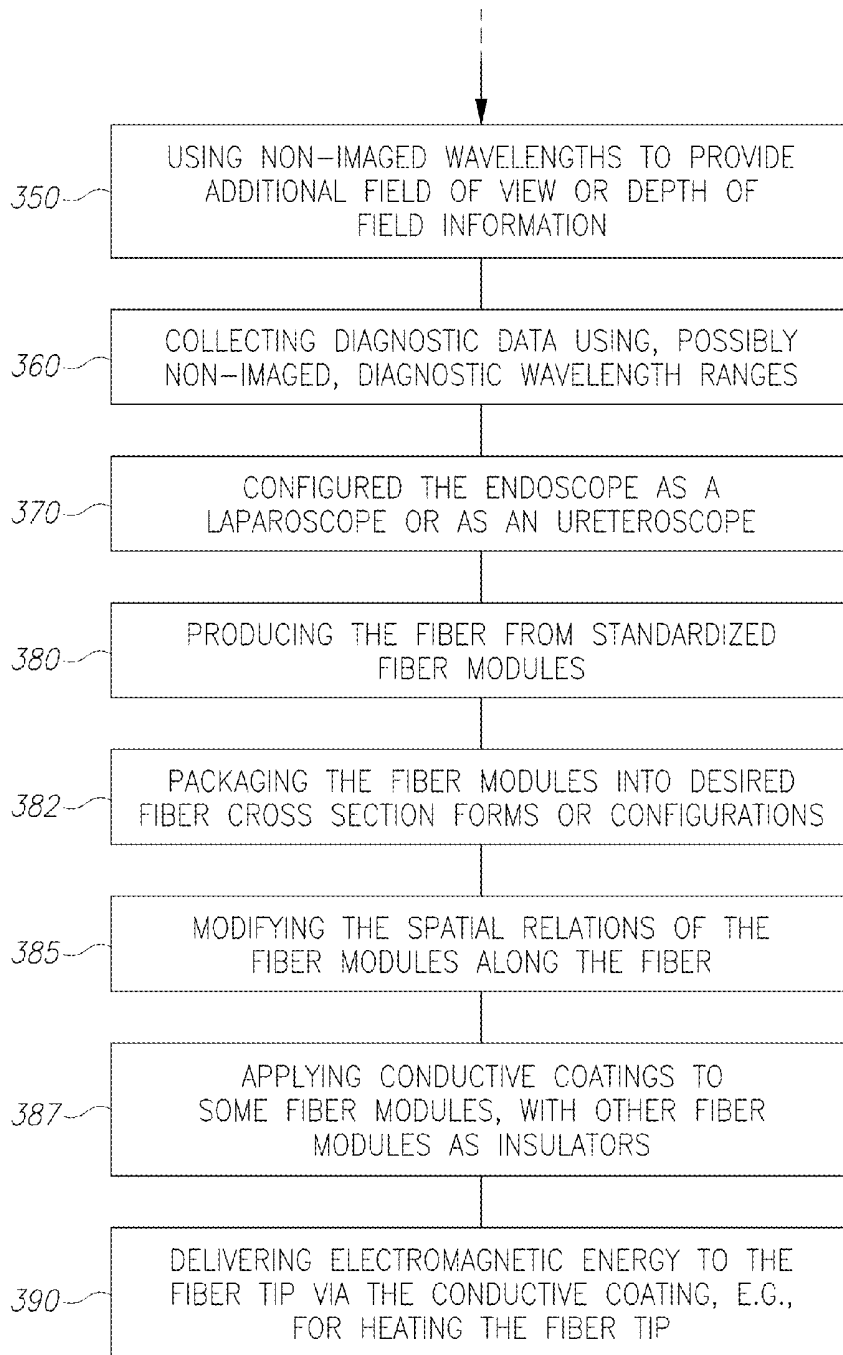

Figure 7 (cont. 4)

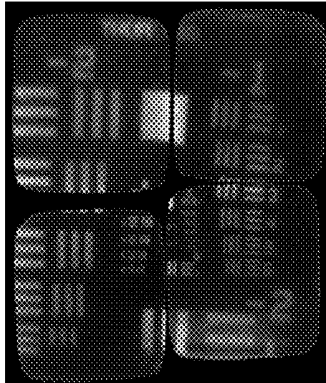

Figure 8A

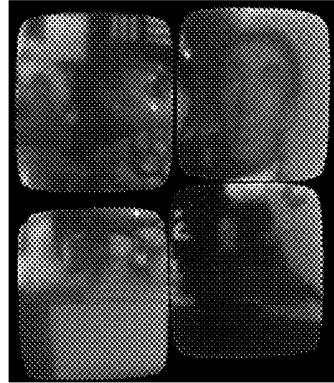

Figure 8B

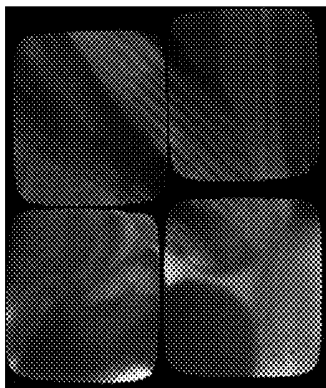

Figure 8C

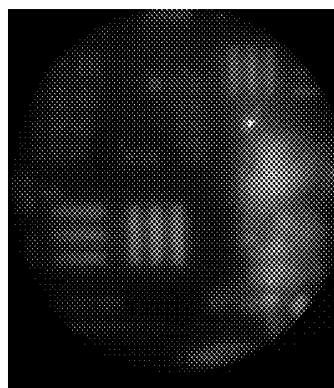

Figure 8D

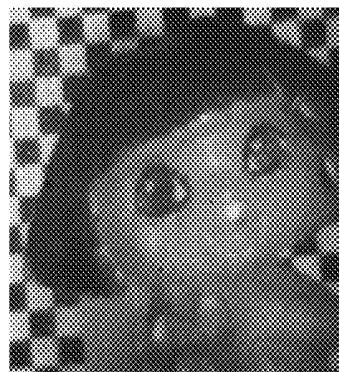

Figure 8E

**MULTICORE FIBER ENDOSCOPES****CROSS REFERENCE TO RELATED APPLICATIONS**

This application claims the benefit of U.S. Provisional Patent Application No. 62/028,346, filed on Jul. 24, 2014, and of U.S. Provisional Patent Application No. 62/119,832, filed on Feb. 24, 2015, both of which are incorporated herein by reference in their entireties.

**BACKGROUND OF THE INVENTION****1. Technical Field**

The present invention relates to the field of endoscopy, and more particularly, to multicore fiber endoscopes.

**2. Discussion of Related Art**

Endo scopes in various configurations allow efficient treatment of a range of medical problems, as well as means for manipulating different situations with limited access. Endo scope operations are challenging in that illumination, detection and treatment are confined to long and narrow operations modes. Fiber optics technology is a central enabler for such techniques, and fiber-based endoscope experience continuous improvements.

**SUMMARY OF THE INVENTION**

The following is a simplified summary providing an initial understanding of the invention. The summary does not necessarily identify key elements nor limit the scope of the invention, but merely serves as an introduction to the following description.

One aspect of the present invention provides an endoscope having a distal tip and a proximal tip, the endoscope comprising: at least one fiber module comprising at least one hundred cores distributed at a fill factor smaller than  $\frac{1}{4}$ , at least one optical element, in optical communication with the cores, at the distal tip, and a detector, in optical communication with the cores, at the proximal tip. The endo scope may be configured to implement super-resolved imaging by micro scanning over a pitch distance between the cores, and at least one of (i) implement three dimensional sensing by handling the cores group-wise with respect to radiation delivered therethrough, (ii) enhance, by configuring the at least one optical element, a field of view of the endoscope beyond a region facing the cores at the distal tip, and (iii) enhance, by configuring the at least one optical element, a depth of field of the endoscope beyond a region congruent to the distal tip.

These, additional, and/or other aspects and/or advantages of the present invention are set forth in the detailed description which follows; possibly inferrable from the detailed description; and/or learnable by practice of the present invention.

**BRIEF DESCRIPTION OF THE DRAWINGS**

For a better understanding of embodiments of the invention and to show how the same may be carried into effect, reference will now be made, purely by way of example, to the accompanying drawings in which like numerals designate corresponding elements or sections throughout.

In the accompanying drawings:

FIGS. 1A-1D are high level schematic illustrations of endo scope configurations according to some embodiments of the invention.

FIGS. 2A-2C are high level schematic illustrations of fiber cross sections having a large number of cores in their electromagnetic propagation region(s), according to some embodiments of the invention.

FIGS. 2D and 2E are high level schematic illustrations of fiber production by packing fiber modules, according to some embodiments of the invention.

FIGS. 3A-3C are high level schematic cross section illustrations of fibers having working channels and additional channel positions for treatment or illumination fibers, according to some embodiments of the invention.

FIG. 3D is a high level schematic illustration of a fiber with an assembled front lens, according to some embodiments of the invention.

FIGS. 3E-3G are high level schematic illustrations of a defogging mechanism and its effects, according to some embodiments of the invention.

FIGS. 4A-4D are high level schematic illustrations of hollow endoscope fibers having optical elements at the distal tip which compensate for the central void, according to some embodiments of the invention.

FIGS. 5A-5C are high level schematic illustrations of optical elements, according to some embodiments of the invention.

FIGS. 6A and 6B are high level schematic illustration of fiber cross sections with different configurations of the cores, according to some embodiments of the invention.

FIG. 6C illustrates comparative experimental results of full core and hollow core fibers, according to some embodiments of the invention.

FIG. 7 is a high level schematic flowchart illustrating a method, according to some embodiments of the invention.

FIGS. 8A-8E are high level schematic illustrations of experimental imaging results for bundled fibers, according to some embodiments of the invention.

**DETAILED DESCRIPTION OF THE INVENTION**

Prior to the detailed description being set forth, it may be helpful to set forth definitions of certain terms that will be used hereinafter.

The terms “distal” and “proximal” as used in this application refer to the ends of the endoscope. The end and associated parts of the endoscope which are far from the endoscope’s interface (detector or eye) and close to the imaged tissue and to its surroundings is termed the distal end, while the end and associated parts of the endoscope which are close to the endoscope’s interface and are remote from the imaged tissue, being typically outside the body is termed the proximal end. The term “reflected” as used in this application refers to a change in a direction of an illumination wavefront which impacts one or more imaged object or tissue. The term “reflection” is understood broadly as any radiation gathered by the fiber, irrespective of the source of the illumination which is reflected by the object(s) and/or tissue(s).

The term “near field imaging” as used in this application refers to the formation of an image (of imaged objects, tissues and/or their surroundings) at the distal end of the endoscope fiber, typically at the fiber’s tip. The imaged is then typically transferred through the fiber to the detector, possibly through proximal optical elements. The term “near field imaging” may relate to different types of optical systems, including direct imaging without any optical ele-

ments between the imaged object or tissue and the fiber tip as well as to imaging through optical element(s) such as lenses.

The term “far field imaging” as used in this application refers to the formation of a Fourier transform of imaged objects, tissues and/or their surroundings at the distal end of the endoscope fiber (i.e., the distal end of the endoscope fiber is at the aperture or pupil plane of the optical system), typically at the fiber’s tip. The image of the imaged objects, tissues and/or their surroundings may be formed at the proximal end of the endoscope fiber, typically at the fiber’s proximal tip or directly on the detector, possibly through proximal optical elements. The term “far field imaging” may relate to different types of optical systems. In one example, “far field imaging” may be direct in the sense that no optical elements are used between the imaged object or tissue and the distal fiber tip, which delivers radiation entering the fiber along the fiber to the detector at the proximal end of the fiber. In another example, “far field imaging” may be carried out with optical elements positioned between the imaged object or tissue and the distal fiber tip, with the distal fiber tip being at least approximately at the Fourier plane (also termed aperture plane and pupil plane in different contexts) of the optical elements.

With specific reference now to the drawings in detail, it is stressed that the particulars shown are by way of example and for purposes of illustrative discussion of the preferred embodiments of the present invention only, and are presented in the cause of providing what is believed to be the most useful and readily understood description of the principles and conceptual aspects of the invention. In this regard, no attempt is made to show structural details of the invention in more detail than is necessary for a fundamental understanding of the invention, the description taken with the drawings making apparent to those skilled in the art how the several forms of the invention may be embodied in practice.

Before at least one embodiment of the invention is explained in detail, it is to be understood that the invention is not limited in its application to the details of construction and the arrangement of the components set forth in the following description or illustrated in the drawings. The invention is applicable to other embodiments or of being practiced or carried out in various ways. Also, it is to be understood that the phraseology and terminology employed herein is for the purpose of description and should not be regarded as limiting.

Endoscopes, multicore endoscope fibers and configuration and operation methods are provided. The fibers may have hundreds or thousands of cores and possibly incorporate working channel(s) and additional fibers. The fiber may be used at different optical configurations to capture images of tissue and objects at the distal tip and to enhance a wide range of optical characteristics of the images such as resolution, field of view, depth of field, wavelength ranges etc. Near-field imaging as well as far-field imaging may be implemented in the endoscopes and the respective optical features may be utilized to optimize imaging. Optical elements may be used at the distal fiber tip, or the distal fiber tip may be lens-less. Diagnostics and optical treatment feedback loops may be implemented and illumination may be adapted to yield full color images, depth estimation, enhanced field of view and/or depth of field and additional diagnostic data.

In the following, various embodiments of multicore endoscope fibers are disclosed. The described embodiments are roughly and not exclusively described in groups relating to the following traits. Certain endoscope embodiments may

implement far field imaging (see FIG. 1A below), i.e., have the image formed at the proximal end of the endoscope fiber, while certain endoscope embodiments may implement near field imaging (see FIG. 1B below), i.e., have the image formed at the distal end of the endoscope fiber. Both far field and near field implementations, may have distal optical elements between the imaged objects or tissues and the distal fiber tip (see FIG. 1C below), or may operate without such distal optical elements (see FIG. 1D below). Each of the four combinations (far field with or without distal optical elements and near field with or without distal optical elements) has different features, advantages and disadvantages as exemplified in Table 1, and may be selected according to specific implementation scenarios. Alternation of the combination may be carried out between applications or in real time, to combine advantages of different configuration types. It is further noted that endoscopes may be designed to have several combinations, e.g., a part of the fiber face (or certain fiber modules) having distal optics for imaging far objects and another part of the fiber face (or other fiber modules) lacking distal optics for microscopic imaging.

TABLE 1

Characteristics of different embodiments		
	Far-field imaging	Near-field imaging
Distal fiber tip	Fourier plane	Image plane
With distal optics	Larger region of interest	Larger field of view, Image multiplexing, larger energetic efficiency
		Larger field of view which may include working channel without compromising (central) regions in the field of view
No distal optics	Wavefront sensing, optical zooming	Auto focus and optical zooming capabilities
	Simpler production and fiber management	

Certain embodiments comprise lens-less embodiments in which the distal fiber tip lacks optical elements. Lens-less embodiments may implement either far-field or near-field imaging, and may utilize structural features to enhance optical resolution, apply super-resolution methods and retrieve wavefront information while reducing crosstalk between the cores.

Endoscope embodiments may have full tip cross sections or have working channel(s) within the imaging fiber characterized by different configurations and uses, integrating additional fibers etc., in which case the cores and optical elements may be configured to overcome the reduction of the field of view due to the incorporation of the working channel.

In the following, various configurations of the large number of cores in the fiber are disclosed, which provide solutions to various issues such as reducing crosstalk between the fibers, overcoming material losses, achieving enhanced resolution by different methods, providing required mechanical characteristics and optimizing the imaging performances of the endoscope fibers. The disclosed endoscopes may serve different purposes, e.g., may be designed as a laparoscope or an ureteroscope. It is noted that elements disclosed in the context of some of the embodiments are not necessarily limited to these embodiments but may be implemented within other embodiments as well.

FIGS. 1A-1D are high level schematic illustrations of endoscope configurations according to some embodiments of the invention. Proposed micro endoscope 105 is con-

structured from large plurality of cores (e.g., one hundred cores or more, hundreds of cores, thousands of cores, in certain embodiments tens or hundreds of thousand cores per fiber or fiber module, reaching over a million cores in certain fiber endoscopes), each responsible for transferring a single or a large number of spatial degrees of freedom out of which at the output, proximal end (the one external to the patient body), a high resolution color image may be constructed. Multi-core fiber 100 exhibits a high degree of flexibility in its optical design, as exemplified below, which may be utilized and adapted for specific applications, for example for uretero scopes with a large working channel and a small external diameter or for laparoscopes with a very high resolution obtained at a small external diameter.

Endoscope 105 may be configured to carry out far-field imaging, near-field imaging or a combination of far-field imaging and near-field imaging. Irrespectively of the imaging mode, endo scope 105 may be configured to have one or more optical elements 140 at a distal tip 101 of fiber 100 or have no optical elements between tip 101 and imaged tissue(s) or object(s) 70. Certain embodiments may comprise removable or reconfigurable optical elements 140 at tip 101 and/or optical elements 140 affecting only parts of the surface of distal tip 101 (e.g., sub-group(s) of the cores).

Certain embodiments comprise endoscopes 105 having a plurality of fibers 100, grouped together, each having at least one hundred cores distributed at a fill factor smaller than  $\frac{1}{4}$ , or even smaller than  $\frac{1}{6}$ , at least one photonic illumination fiber, and at least one optical element at a distal tip of fibers 100, which may be configured to enhance a field of view and/or a depth of field of endoscope 105 beyond a region facing a tip of fibers 100 and congruent thereto (see details below). Endoscope 105 may be further configured to implement three dimensional sensing by handling the cores group-wise with respect to radiation delivered therethrough (see details below). Endo scope 105 may be further configured to super-resolved imaging by micro scanning over a pitch distance between the cores (see details below). Endoscope 105 may be configured to comprise a LED (light emitting diode) light source located at distal tip 101 as the illumination source.

FIG. 1A schematically illustrates far-field imaging, in which an image 73 (indicating any kind of electromagnetic signal reflected from tissue or object 70) is delivered through tip 101 and fiber 100 to yield image 75 on detector 91. Tip 101 may be a Fourier plane (also termed aperture plane or pupil plane) at which the Fourier transform 74 of image 73 enters fiber 100. It is noted that the Fourier plane may be located anywhere along fiber 100 as well as distally or proximally to fiber 100, in different embodiments of the invention, and be optically transformed to image 75 on detector 91. Alternatively or complementary, Fourier image 74 or derivatives thereof may be measured at detector 91, and/or manipulated to enhance imaging parameters such as resolution, field of view and depth of focus, as non-limiting examples. Optical elements may be introduced distally or proximally to fiber 100 to modify or manipulate the radiation entering tip 101 and the radiation falling on detector 91, respectively.

FIG. 1B schematically illustrates near-field imaging, in which image 73 yields image 75 at fiber tip 101. Image 75 is then delivered, possibly through optical elements, to detector 91 through fiber 100. It is noted that image 75 may be formed within fiber 100 and not necessarily exactly at tip 101. Image 75 delivered via fiber 100 may be measured at detector 91, and/or manipulated to enhance imaging parameters such as resolution, field of view and depth of focus, as

non-limiting examples. Optical elements may be introduced distally or proximally to fiber 100 to modify or manipulate the radiation entering tip 101 and the radiation falling on detector 91, respectively.

FIG. 1C schematically illustrates optical configurations having one or more optical element(s) 140 at the distal end of fiber 100, at proximity to imaged tissue 70. Optical element(s) 140 may be attached to tip 101 or may be somewhat distally removed from tip 101 (e.g., held by spacers at a distance therefrom). Each optical element 140 may be in optical communication with a respective core or a respective group of cores. Proximally, illumination 85 is delivered to fiber 100 and reflected illumination (e.g., in far-field or in near-field) is directed from the cores to a detector 91, e.g., via a beam splitter 90. Proximal optical elements may be set and used to manipulate illumination 85 and the reflected illumination, as symbolized below (FIG. 1D) by lenses 84, 94 respectively. One or more processor(s) 99 may be configured to control the illumination and/or process the detected illumination, as well as control illumination and image beams in case there are controllable elements in the optical path.

FIG. 1D schematically illustrates optical configurations having no optical element(s) (also termed below "lens-less" configurations) at the distal end of fiber 100, so that fiber tip 101 is used directly to deliver and receive illumination to and from imaged tissue 70. Illumination 85 is delivered to fiber 100 proximally, e.g., via an optical element 84 such as a lens, and reflected illumination is directed to detector 91 via another optical element 94, e.g., a lens. One or more processor(s) 99 may be configured to control the illumination and/or process the detected illumination, as well as control illumination and image beams in case there are controllable elements in the optical path. In certain embodiments, lens-less configurations may be configured to generate image at "contact mode", i.e., with close proximity of the fiber tip to the examined tissue, to yield microscopic resolution determined by the sizes of the cores.

In certain embodiments, proximal optical elements 94 (and possibly optical elements 84 too) may be variable and be used to adjust the plane and depth of focus of captured images in far-field imaging configurations, especially in lens-less configurations.

FIGS. 2A-2C are high level schematic illustrations of fiber cross sections having a large number of cores 115 in their electromagnetic propagation region(s) 110, according to some embodiments of the invention. Fiber(s) 100 may comprise central or eccentric optical cores (110) and/or may have hollow, central or eccentric region(s) (112) that may be used for treatment such as energy delivery, suction, illumination, drug delivery etc. Illumination means may be integrated in various ways within the multicore fibers 100. Selection of near-field or far-field configurations, as well as selection if and which optical elements 140 are inserted distally to the tip, may be carried out under consideration of the tradeoffs between the different applications (see, e.g., Table 1 and other examples below). For example, considerations concerning production, use, optical characteristics and algorithmic parameters may be balanced differently at different embodiments to optimize endo scope 105 to a wide range of performance and device requirements.

Fiber 100 illustrated in FIG. 2A may have any form of cross section, e.g., square as illustrated in a non-limiting manner, round, hexagonal, elliptic etc. While FIG. 2A illustrates a solid cross section of fiber 100, FIG. 2B illustrates hollow endoscope having a void 112 within fiber 100 that may be used for different purposes as disclosed below

(e.g., as a working channel for inserting a tool or carrying out suction, for incorporating additional fibers etc.). Fibers **100** may be square, round or have any other form, and void **112** may too have any shape and any position within fiber **100**, void(s) **112** and fiber **100** may have any dimensions ( $R_c$ ,  $R_o$ ,  $D$ ,  $W$  etc.), and voids may also be multiple (i.e., fiber **100** may enclose two or more voids), all designed according to requirements from the endoscope. FIG. 2C schematically illustrates multicore fiber **100** with cores **115** grouped into "super core" groups **116** that may be configured to sense wavefronts in lens-less configurations, as explained below.

Multicore fiber **100** may be made of biocompatible materials in case of medical uses, e.g., polymers such as PMMA (poly-methyl methacrylate) and PS (polystyrene) and may be flexible. Fiber **100** may also be made of non-compatible materials and be flexible or rigid in case of industrial uses. Fiber **100** may be configured to have a flexibility characterized by a Young's modulus smaller than 10 GPa and to be disposable. Fiber **100** may thus be more flexible than glass fiber (having a Young's modulus of about 65 GPa), and may reach PMMA flexibility (Young's modulus between 1.8 and 3.1 GPa) or higher flexibility.

Various embodiments compensate for the reduced transparency of polymer fibers with respect to glass fibers, using means such as fiber materials, configuration of cores and interspaces, number and sizes of cores, material modifications of different fiber parts, control over the number of propagation modes in cores **115**, optical means such as lenses or prisms at either side of fiber **100** and their configuration, design and application of different types of illumination and algorithmic solutions, all of which are exemplified below in a non-limiting manner. The following disclosure also addresses ways to control cross talk between cores **115** (i.e., interaction effects between radiation propagating in adjacent cores **115**) and ways to improve the information content and to enhance treatment-relevant information of the detected images.

Illumination may comprise coherent light or incoherent light, any spectral pattern (broad or narrow wavelength ranges, continuous or discrete ranged), polarized (in various patterns) or non-polarized light and different ranges in the visual or infrared ranges. Material differences between cores, interspaces and outer cladding may comprise different materials, using air cores or air interspaces, and doping any of the fiber regions to influence their refractive indices, as explained in more details below. It is noted that any of the embodiments presented below may be used in any of the other embodiments described herein, as long as they are compatible. Particularly, computational methods optical methods and fiber design considerations described in the context of any embodiment may be applied to other embodiments as well.

FIGS. 2D and 2E are high level schematic illustrations of fiber production by packing fiber modules, according to some embodiments of the invention. Multi-core fibers **100** may be produced using fiber modules or units **117**. Each fiber module **117** is itself a multicore fiber, possibly configured to have uniform dimensions. Such embodiments are referred to as bundled fibers, and may bundle any number of fiber modules **117** in any configuration (e.g., 2x2 modules, 3x3 modules etc.). Fiber module **117** may have any form, such as square, rectangular, round or elliptic, and may be packed into fibers **100** having a wide range of forms and configurations. Introducing fiber modules **117** having an intermediate dimension between cores or core groups and whole fiber **100** (each module **117** may have e.g. tens, hundreds or thousands of cores) enables simpler production

and higher flexibility on forming fiber **100** from fiber modules **117**. For example, as illustrated in FIG. 2D, rectangular fiber **100** may be assembled from rectangularly arranged square fiber modules **117**, e.g., using a package support **118A** and a respective attachable cover **118B**. Fiber modules **117** may simply be mechanically held by package support **118A** and cover **118B** at certain regions along fiber **100** and/or fiber modules **117** may be glued together or otherwise attached at least at certain regions. In another example, illustrated in FIG. 2E, fiber modules **117A**, **117B** may be arranged around void **112**. In certain embodiments, fiber modules **117A**, **117B** may be arranged to differ in their observation angles and/or in optical elements **140** attached at fiber tip **110** (see, e.g., below, FIGS. 4A-4D). For example, fiber units **117A** may be configured to cover a field of view in front of void **112** (e.g., be inclined inwards or have respective optical elements) while fiber units **117B** may be configured to cover a field of view laterally beyond tip **101** (e.g., be inclined outwards or have respective optical elements). For example, non-limiting inclination angles may be 5-20° inwards and 10-50° outwards. Respective packaging or attachment configurations may be applied to fixate fiber modules **117A**, **117B** in their respective positions and angles. In certain embodiments, the annular arrangement of fiber modules **117A**, **117B** may be at the fiber's distal end, while fiber modules **117A**, **117B** may be separated and re-arranged differently at the fiber's proximal end, e.g., into a rectangular form to cover a face of a single rectangular detector. Thus, flexibility in production and use is achieved, enabling independent optimization of the spatial distribution of the fiber modules at either end of fiber **100**, to enhance both the optical sensing at the distal end as well as the detection and processing at the proximal end.

FIGS. 3A-3C are high level schematic cross section illustrations of fiber **100** having working channel **112** and channel positions **120** for treatment or illumination fibers, according to some embodiments of the invention. Working channel **112**, depicted as void **112** within fiber **100**, is surrounded by electromagnetic propagation multicore fiber region **110**. Treatment and/or illumination fiber(s) may be integrated into fiber **100** of the endoscope in a way that allows combined imaging and treatment using one fiber, immediate image feedback of the treatment etc. Such combination may be used, e.g., as ureteroscope or as any other type of endoscope. In certain embodiments, positioning additional fibers in channels **120** near working channel **112** may be configured to cool down the fibers (e.g., treatment fibers) by the liquids flowing through working channel **112**.

In the illustrated examples, treatment or illumination fibers may be inserted at indicated positions **120** (e.g., grooves, or channels), e.g., at an inner wall of multi-core imaging region **110** in fluid communication with working channel **112**, i.e., on the periphery of voids **112** (FIG. 3A, channel diameter, e.g., ca. 250  $\mu\text{m}$ ), at an outer wall of multi-core imaging region **110** in fluid communication with the surroundings of fiber **100**, i.e., on the periphery of fiber **100** (FIG. 3B, channel diameter, e.g., ca. 250  $\mu\text{m}$ ), within multi-core imaging region **110** (FIG. 3C, channel diameter, e.g., ca. 200  $\mu\text{m}$ ), or combinations of these possibilities. Integration of the treatment or illumination fibers may be carried out before, during or after production of fiber **100**. In certain embodiments, glass treatment or illumination fibers may be inserted into grooves **120** after pulling polymer fiber **100**.

In certain embodiments, treatment or illumination fibers may be configured and controlled to operate collectively, simultaneously or sequentially, to achieve a desired illumina-

nation and/or treatment. For example, the treatment channel may be split into several low power channels **120** to have thinner channels and lower power delivery through each channel. Such configuration may enable increasing the mechanical flexibility of the endoscope, which is very important, e.g., in the field of ureteroscopy. Furthermore, the usage of hollow channels **120** for inserting the external illumination or treatment fibers provides a device configuration exhibiting self-alignment.

FIG. 3D is a high level schematic illustration of fiber **100** with an assembled lens **119**, according to some embodiments of the invention. A modular construction of fiber **100** (see, e.g., FIGS. 2D, 2E) may be used to modify some of fiber modules **117** to incorporate features into fiber **100** in a simpler manner than incorporating these features into a uniform fiber. Fiber modules **117D** may be configured in a modular, building block style manner to form various cross sectional organizations with respect to form and functionality of the endoscope. In the illustrated example of certain embodiments, two non-adjacent fiber modules **117D** may be coated with a conductor (e.g., a metal) while the rest of fiber modules **117C** may be uncoated (and insulating). Such configurations may be used to deliver electricity to fiber tip **101**. For example, electromagnetic signals or electromagnetic radiation may be delivered via fiber modules **117D** to adjacent tissues or to associated devices or components (e.g., checking equipment or endo scope instrumentation). In the illustrated example, electromagnetic energy may be delivered to distal lens **119** for heating it to prevent fogging upon entry to the body. In certain embodiment, an antenna structure (not shown) may be designed upon lens **119**, which receives electromagnetic radiation to heat lens **119** without using contacts. In certain embodiments, radiofrequency (RF) treatment may be applied to tissue or objects surrounding fiber tip **101** via the conductive coating of fiber modules **117D**.

FIGS. 3E-3F are additional high level schematic illustrations of a defogging mechanism **121** and its effects, according to some embodiments of the invention. FIG. 3E illustrates lens **119** coated by a conductive coating **122** connected to an electric circuit **123** configured to heat lens **119** via coating **122**, to prevent fog and to defog lens **119** when required. FIG. 3F exemplifies image deterioration by fog accumulation—the top image (A) taken a short time after the beginning of fog accumulation, the bottom image (B) taken later, with the object, marked by an arrow, barely visible. FIG. 3G illustrates the image after defogging—both object and illumination spot are clear again.

In certain embodiments, endoscope **105** may be operated in the far field (FIG. 1A) or in the near field (FIG. 1B) by properly adapting the focal length of the external optics (the one outside the patient's body, e.g., optical elements **84**, **94**) to the working distance of treated tissue **70** from the distal tip of the endoscope. Fiber **100** may be configured to deliver full images even with working channel **112** in the middle of the imaging surface by employing far field imaging, e.g., using imaging lens **94** adapted to have a central blocked aperture.

In far field imaging configurations having lens-less fiber tip **101**, obtained images may have a number of pixels that is not related to the number of cores **115**, enhancing the image resolution with respect to near field embodiments. For example, certain embodiments comprise using as detector **91** an integral imaging sensor capable of sensing wavefront or the 3D topography of inspected tissue **70**. In such embodiments, cores **115** may be configured to have a small

number of possible spatial modes, resembling the Shack-Hartmann interferometer or a wavefront sensor.

In certain embodiments, cores **115** may be grouped into “super-cores” **116** (see FIG. 2C), each comprising a group of adjacent cores **115**. Each “super-core” **116** may be handled as a single wavefront sensing element which delivers information about the wavefront by comparing radiation propagating through individual core members **115** within each “super-core” **116** (or light field sensing, i.e., comparing light directions at different cores operating in near field and multi-mode). The grouping of cores **115** into “super-cores” **116** may be uniform across the face of fiber **100** or be variable, some core groups being larger than others, see, e.g., the larger central core group in FIG. 2C).

The grouping of cores **115** may be changed in time according to imaging performance preferences, based, e.g., on an even (or uneven) distribution of cores **115** across fiber **110**. It is noted that in such configurations a tradeoff exists between depth measurements and resolution. A larger number of cores **115** in each “super-core” **116** provides more details about the three dimensional structure of the imaged region by using more detailed wavefronts, while smaller numbers of cores **115** per group **116** and no grouping at all provide higher resolution. The grouping of cores **115** may hence be designed or modified according to spatially and temporally changing imaging requirements. Complementarily, cores **115** may be handled by processor **99** group-wise with respect to the radiation delivered therethrough, to implement each group **116** as a wavefront sensor. The allocation of cores **115** to core groups **116** may be carried out dynamically, e.g., by processor **99**. Additionally, grouping considerations may accompany other considerations regarding imaging performance such as suggested techniques for enhancing resolution and/or depth measurements.

In certain embodiments, near field implementations may comprise sensing the light field between the cores (operating in multi-mode), i.e., measuring directional components of the radiation to yield 3D imaging. Light field sensing may be carried out groupwise with respect to the core grouping.

In certain embodiments, endoscope fiber **100** may comprise multiple cores **115** that are not positioned at equal distances but interspaced unevenly (see FIG. 2A for a schematic illustration). Uneven (irregular) distribution of cores **115** (e.g., a spatial distribution that does not coincide with the spatial distribution of pixels on detector **91**) enables, when working in the far-field conditions, to obtain super resolved images since the sampling of cores **115** in the aperture plane (Fourier plane) is not uniform and thus the sampling at the aperture plane does not affect the field of view or generate visible limitations in the image plane. The distribution of cores **115** and the interspaces across fiber **100** may be designed to optimize resolution enhancement using algorithmic and optical techniques. Indeed, increasing the distances between cores **115** may provide larger benefits from micro-scanning and application of other super resolution techniques.

In certain embodiments, the optical design of fiber tip **101** may be configured to have working channel **112** positioned asymmetrically and not centrally within the cross section of the tip (not concentric to the imaging channel). The shape of working channel **112** may be configured to different than circular (e.g., elliptic, elongated, polygonal, etc.) in order to better encode the optical transfer function (OTF). The working channel shape may be configured to improve inverting the OTF and the algorithmic correcting of the image via the image post processing to yield a super resolved image.

In certain near-field imaging embodiments, an increased depth of focus may be achieved in lens-less embodiments by selecting the best focal positions that can provide the sharpest contrast per each pixel in the generated image, from images captured at different tip positions with respect to tissue 70. The best focus for each pixel may be selected from a plurality of images captured at different tip positions.

In certain embodiments, optical elements 140 may be attached to or produced at distal fiber tip 100 (facing tissue 70). Optical elements 140 may be used to enhance imaging in both far-field imaging and near-field imaging. For example, optical elements 140 may be used to control the field of view, increasing it beyond the edges of tip 101 outwards and/or inwards (in case of a designed working channel void 112).

FIGS. 4A-4D are high level schematic illustrations of hollow endoscope fiber 100 having optical elements 140 at distal tip 101 which compensate for the central void, according to some embodiments of the invention. In embodiments with void(s) 112 at the cross section of fiber 100 at tip 101, various solutions are presented below for imaging a void-facing area 72 in addition to (or in place of) region 71 facing cores 115. It is noted that any type of target 70 may be imaged, e.g., tissue, specific anatomical members, bodily fluids, various stones or obstructions, tumors, foreign bodies etc.

In certain embodiments, illumination source 85 of endoscope 105 and at least some of the optical elements (e.g., tip optical elements 140, proximal optical elements 84, 94) may be configured to image at least a part of the area facing void(s) 112 (i.e., void-facing area 72) differently than a rest of the region facing tip 101 (i.e., core-facing region 71). The difference in the imaging may lie in any of polarization, wavelength, wavelength range and/or timing of the illumination. Non-limiting examples are presented in the following.

Multiple cores 115 may be used to generate a full image, overcoming the lack of cores in hollow region 112 and providing imaging (and illumination) of tissue 70 directly opposite to working channel 112 (void-facing area 72). For example, endoscope 105 may be configured to provide a 90° field of view of fiber 100. FIG. 4A schematically illustrates in a non-limiting manner an annular multicore region 110 (with an inner radius  $R_i$  and an outer radius  $R_o$ ) having annularly arranged optical elements 140. Similar principles may be applied to any geometric configuration of fiber tip 100, e.g., any form thereof, any position and form of void(s) 112, etc.

In certain embodiments, optical elements 140 may comprise gradient index (GRIN) lenses cut at specified angles and glued at tip 101 of micro endoscope 105. Each cut GRIN 140 may be cut and positioned to face a different direction in order to enhance the fiber's field of view (FOV) to equal the number of GRINs 140 multiplied by the FOV of each GRIN 140 (or, complementarily or alternatively, enhance the depth of field by configuring some of GRINs 140 to deliver radiation from different depths of field). The cut of the edge of GRIN lenses 140 may realize a prism coupling light into that specific GRIN from different predefined sectors of the field of view. Aspheric lenses may be used as alternative to GRIN lenses as optical elements 140.

FIGS. 4B-4D schematically illustrates three possible configurations, according to some embodiments of the invention. The large circle schematically represents the periphery of the total FOV of fiber tip 101, which is the boundary of the imaged region facing the cores (71), while the small circles represent the fields of view of individual optical

elements 140, 141, taken in a non-limiting illustrative case to be equal. For example, tip FOV (region 71 plus void-facing area 72) may be covered by equally spaced (in FIG. 4B eight) optical elements 140 each imaging a peripheral region 145, and an additional optical element 141 may be configured to image a central region 146. Void-facing area 72 is thus covered centrally by region 146 and its periphery is covered by regions 145. In another example, a larger number (in FIG. 4C twenty one) of optical elements 140 may be configured to have angles covering tip FOV in several concentric circular sets of imaging regions—in the illustrated example twelve peripheral regions 145, eight intermediate regions 146 and one central region. In another example, annularly arranged optical elements 140 (in FIG. 4D twenty five) may be configured to have angles covering the tip FOV in a grid-like manner individual regions 145 partly overlapping and covering tip FOV and possible extending into a larger area. This disclosed method provides high flexibility in adapting fiber tip optical elements 140 to yield a required field of view.

In certain embodiments, optical element 140 may comprise an annular lens coupled to an annular prism that directs light from the whole FOV into the annular lens.

In certain embodiments, possibly without the ring of optical elements described above, the center of FOV may be imaged using selective illumination. Illumination may be directed to the center of FOV and not to its periphery, and accompanying algorithms may be configured to process the detected signals to derive images of the FOV center (e.g., by processor 99).

In certain embodiments, illumination having different polarizations may be used for the central FOV (e.g., void-facing area 72) and for the periphery of FOV (e.g., core-facing region 71), so that the detected signal is spatially encoded by the difference in polarization, and may be decoded to create images of the whole FOV (see more elaborate explanation below). Optical elements 140 may be birefringent to directly differently polarized illumination to different geometric areas.

In certain embodiments, void 112 may be eccentric or divided into eccentric voids, leaving rooms for ventral cores to image the center of the FOV directly.

In certain embodiments, cores 115 may be unequally or non-uniformly spaced within fiber 100, e.g., such that the positions of cores 115 do not coincide with the uniform spatial sampling matrix of the pixels of detector 91 positioned outside the body. The lack of coinciding between the two grids may be utilized to apply geometric super resolving algorithms to improve the quality of the captured image (resembling in a sense the micro-scanning technique).

Certain embodiments may implement micro scanning via the spatial core configuration. For example, fiber 100 may exhibit multicore designs having a low fill factor (the fill factor is the ratio between the core area and the square of the distance between cores, the latter termed pitch). For example, the core diameter may range between 0.4-2.5  $\mu\text{m}$  and the pitch may range between 2-10  $\mu\text{m}$  to yield a range of low fill factors ( $1/(\text{pitch}/\text{core diameter})^2$ ), e.g., fill factors between  $1/4$  and  $1/16$ . When the fill factor is low (e.g., below  $1/4$ , below  $1/6$ , e.g.,  $1/16$ ), simple movement of tip 101 of the micro endoscope (e.g., movement amplitude may equal at least the pitch, i.e. a few microns) enable implementation of the micro-scanning concept to significantly increase the geometric resolution of the device. (It is noted that, in case of imaging with large fill factor, the micro scanning procedure cannot increase the geometric resolution of the image but rather only to perform over-sampling of the image,

because the point spread function (PSF) of the sampling pixel/core itself limits as a spatial low pass the obtainable resolution.) In certain embodiments, spatial scanning methods and temporal scanning methods according to the present disclosure may be combined and adapted to imaging requirements.

In certain embodiments, illumination channel **85** may have time-varying optics which realizes a spatial scanning of the illumination spot. The spatial illumination scanning may be used to construct a wide field image having large field of view which is not affected by the working channel positioned in the center of the tip even if the tip is in near field with respect to the inspected tissue.

In any of the embodiments, processor **99** may be configured to process into images radiation delivered from the imaging region through cores **115** to detector **91** and possibly to implement super-resolution algorithms on the detected radiation.

In certain embodiments, inspected tissue **70** may be illuminated by a tunable laser as illumination source **85**. A set of spatial images of tissue **70** may be captured, each image corresponding to a different wavelength. The resulting is hyperspectral image may be used for identification of specific types of tissues (e.g., cancerous tissue) to enhance the imaging. Thus, fiber endo scope **105** may provide diagnostic possibilities carried out using different wavelengths (in a specified diagnostic wavelength range, such as infrared wavelengths used to measure hemoglobin oxygenation) that are used for specific purposes and not necessarily for the imaging illumination. The selection of wavelengths and wavelength bands may be changed during the procedure, manually or automatically, to adapt to different stages in the procedure and different imaging requirements with respect, e.g., to spatial or temporal parameters, encountered site and tissue, etc. In one example, single wavelength bands may be illuminated and analyzed separately, to enhance the derived information. Given wavelength bands may be used to illuminate the target from different directions to yield more detailed spatial information.

In certain embodiments, working channel **112** of endoscope **105** configured as an uretero scope may be used to suck out large kidney stones and attach the stones by suction to tip **101** of the endo scope. Treatment laser (possibly incorporated in fiber **100**, see FIGS. **3A-3C**) may then be used to break the stones while the sucking stabilizes the stones and prevents them from moving around during the medical treatment. Suction may be applied through working channel **112**, and the imaging may be used to provide feedback regarding the efficiency of the suction and the treatment. For example, intensive treatment may tend to overcome the suction and release the attached stone. The imaging may be used to detect the development of stone disengagement from fiber tip **101** and to adjust suction and/or applied energy respectively. In this context, splitting of energy application into several fibers as described above may provide more uniform treatment of the stone that employs lower energy concentration at any one point of the stone. Energy application intensity may be regulated at each of the energy sources to avoid stone disengagement from the suction.

In certain embodiments, working channel **112** of the uretero scope may be used to inject liquid and to slightly change the optical conditions of fiber **100** such that effectively the focal length of lens **140** at tip **101** is changed and focal scanning can be realized to produce the sharpest possible image per each pixel in the image.

Endo scope **105** may be configured as any type of endo scope and be used to handle any type of bodily stones or other obstructions.

FIGS. **5A-5C** are high level schematic illustrations of optical elements **140**, according to some embodiments of the invention. In certain embodiments, a polarizing optical element **150** (e.g., a Glan Thompson prism) may be implemented at the end of fiber **100** (FIG. **5A**) in addition to imaging lens(es) **140** at tip **101** of the micro-endoscope (e.g., a GRIN lens, aspheric lenses). Polarizing optical element **150** may be configured to increase FOV by polarization multiplexing beyond the limitations of optical element(s) **140**. Different fields of view **130A**, **130B** may be polarization-encoded, folded into endoscope fiber **100** and separated at the output (e.g., using a polarized beam splitter (PBS) **93** before reaching detectors **91**, **92**). Polarization-encoding may be carried out using different linear polarization directions (e.g., with 45° therebetween), circular polarization etc. Polarization multiplexing may be used to increase the imaged area either laterally or centrally (see above), depending on the configurations of fiber **100** and the optics. Polarization multiplexing may be combined with temporal scanning of the field of view. Polarization multiplexing may be used to enhance three dimensional depth imaging in place or in addition to enlarging the field of view. Different processing algorithms may be applied to the signals of detectors **91**, **92** to provide additional information at regions from which both polarization types are detected. Illumination source **85** for polarization multiplexing may be non-polarized (with separation to polarization component being carried out optically), or polarized and have both components.

FIGS. **5B** and **5C** schematically illustrate embodiments for optical elements **140**, **150** at fiber tip **101**, namely an angle deflecting element **150** (e.g., a prism) and an imaging optical element **140** (FIG. **5B**) and a combined configuration with a faceted GRIN lens **140** (FIG. **5C**).

In certain embodiments, certain parts of FOV may be imaged by different optical elements **140** (and respective cores **115**) to enable optical triangulation, i.e., distance measurement from tip **101** and the tissue region. Such embodiments allow to trade-off FOV with depth information and thus dynamically allocate imaging resources (e.g., FOV—Field of View, DOF—Depth of Field) according to situation dependent needs. In certain embodiments, different polarizations may be used by different optical elements **140** imaging the same region, so that using polarization enhances depth information instead or in addition to extending the FOV (as explained above). Dynamic variation of polarization may be used to modify the optical performance of fiber **100** during operation. In certain embodiments, different wavelengths may be used by different optical elements **140** imaging the same region, so that using wavelength multiplexing (e.g., using a tunable laser as explained above) enhances depth information instead or in addition to extending the FOV (as explained above). Dynamic variation of color allocation may be used to modify the optical performance of fiber **100** during operation. For example, multiple laser sources having different wavelengths may be used as illumination source **85**, e.g., four channels, three of which used to yield color imaging and the fourth used to derive image depth information via triangulation computation. In certain embodiments, the wavelength used for the fourth channel may be identical to the wavelength used in one of the other three channels to facilitate or simplify the triangulation computation.

In certain embodiments, endoscope **105** may be configured to use at least one non-imaged wavelength range, selected to provide additional depth of field or field of view information. In certain embodiments, polarization, wavelength or spatial multiplexing may be used to image a tissue region from different directions, to enable stereoscopic vision of the tissue region. Processor **99** may be configured to derive and provide stereo-imaging.

In certain embodiments, endoscope **105** may be configured to provide two or more levels of resolution, allow balancing field of view information and depth of field information, or allow balance between any other image parameters by adapting the illumination and/or the image processing procedure disclosed herein.

FIGS. **6A** and **6B** are high level schematic illustration of fiber cross sections with different configurations of the cores, according to some embodiments of the invention. FIG. **6C** illustrates comparative experimental results of full core and hollow core fibers, according to some embodiments of the invention.

The configuration of the cores (dimension, material, interspaces) may be designed to reduce crosstalk between cores **115** and to be less affected by its banding. For example, crosstalk reduction may be achieved in the fabrication process by generating physical barriers between the cores or by using anti-crosstalk layer(s). Core spacing may be selected to reduce crosstalk between adjacent cores **115** below a specified threshold. For example, crosstalk may be reduced by spacing the cores (e.g., by at least  $4\mu$  between cores) and by increasing the refraction index difference between the cores and the cladding. The cores may be interspaced by structures such as air holes or doped polymer material (e.g., with incorporated nanoparticles). Cores **115** may be hollow, made of polymer material and/or include nanoparticles to control the refractive index. In certain embodiments, contrast may be enhanced by placing the hardware with the external holes array. In certain embodiments, an optical element (e.g., optical element **94**) may be added between the output of fiber **100** and the imaging system and configured to block the output coming from cladding **113** thus transferring only the information going out from optical cores **115**. The optical element may comprise an intensity mask having a value of one for all core locations and a value of zero for all cladding locations to make all and only information from the cores to propagate to detector **91**.

In certain embodiments, the difference in the refraction index between cores **115** and cladding **113** may be designed to be large enough, and/or intermediate elements **111** may be introduced to reduce interaction between radiation propagating in different cores **115**. Core **115** and/or cladding **113** and/or elements **111** may comprise polymer with incorporated nanoparticles. Due to plasmonic resonance of the nanoparticles at specific wavelengths an effective increased refraction index may be obtained for the doped material. The specific wavelengths may be selected to be close to wavelength bands (e.g., within a few nm, e.g.,  $\pm 5$  nm at most) of illumination source **85** (e.g., three or four color lasers). It is noted that as both the plasmonic resonance and the bandwidth of illumination lasers are narrow, they may be matched to yield an effectively increased refractive index by the nanoparticles at the illumination wavelengths.

In certain embodiments, hollow cores through which no light coupling is obtained may be interlaced as intermediate elements **111** between cores **115** (see FIG. **6A**). Hollow cores **111** may be used to reduce the effective refraction

index difference between light conducting solid cores **115** and their surrounding medium **113**.

In certain embodiments, cores **115** may be hollow (FIG. **6B**) and be isolated by doped or non-doped solid polymer. Hollow cores **115** (air holes) were shown to very significantly reduce material losses (FIG. **6C**) and are thus exceptionally advantageous when using polymer fibers **100** which are characterized by relatively large losses compared to glass fibers. The main advantage of polymer fibers is their flexibility, enable strong bending which is required under certain endoscope applications (e.g., treating kidney stones as presented above).

Fiber materials (for cladding **113** and intermediate elements **111** if any) and doping may be selected according to the required refractive indices and mechanical properties of fiber **100**, and may comprise various types of biocompatible (or not biocompatible, e.g., in non-medical uses) polymers, possibly doped with nanoparticles to influence the refractive indices. Either or both illumination wavelength ranges and types of nanoparticles may be selected to optimize the changes in the refractive indices to optimize the radiation transfer through the cores. In any of the embodiments, core diameter  $D_1$ , diameter of intermediate elements  $D_2$  and distance between cores  $L$  may be configured to achieve specified optical performance parameters.

FIG. **7** is a high level schematic flowchart illustrating a method **200**, according to some embodiments of the invention. Data processing stages and control stages may be implemented by respective processors and algorithms may be implemented by respective computer program product(s) comprising a computer usable medium having computer usable program code tangibly embodied thereon, the computer usable program code configured to carry out at least part of the respective stages.

Method **200** comprises configuring an endoscope from a fiber with at least several hundred cores (stage **210**), e.g., having a multi-core imaging region or a multi-core tip configured to deliver reflected illumination along the fiber for an external detector. Method **200** may comprise implementing near-field imaging (target imaging at the fiber tip) (stage **212**) and/or implementing far-field imaging (Fourier plane at the fiber tip) (stage **214**).

In certain embodiments, method **200** may comprise configuring an endoscope from a plurality of fibers, grouped together, each having at least one hundred cores distributed at a fill factor smaller than  $1/4$ , or even below  $1/6$ , and at least one photonic illumination fiber, implementing three dimensional sensing by handling the cores group-wise with respect to radiation delivered therethrough, implementing super-resolved imaging by micro scanning over a pitch distance between the cores, and configuring at least one optical element at a distal tip of the fibers to enhance a field of view and/or a depth of field of the endoscope beyond a region facing a tip of the fibers and congruent thereto.

Method **200** may comprise at least one of the following stages for reducing losses and/or cross talk between cores: incorporating in the cladding, nanoparticles with plasmonic resonances that are in proximity to illumination (and imaging) wavelengths (stage **220**); interspacing cores by intermediate elements (possibly incorporating nanoparticles) having a different refractive index than the cores (stage **230**), e.g., by 0.1; interspacing cores by air holes (stage **235**) and configuring cores as air holes (stage **240**), and may comprise reducing crosstalk between adjacent cores by interspacing them (stage **245**).

In certain embodiments, method **200** may further comprise incorporating one or more void(s) in the fiber as working channel(s) for treatment, suction and/or illumination (stage **250**).

In certain embodiments, method **200** may further comprise splitting treatment and/or illumination into several fibers operating collectively (stage **260**) and/or incorporating additional fibers at the periphery of the fiber or of the void(s) (stage **265**). Method **200** may comprise cooling incorporated fibers through the working channel (stage **267**). In certain embodiments, method **200** may further comprise controlling treatment and/or suction optically or automatically using optical input during the treatment (stage **270**), and treating bodily stones by the endoscope, e.g., kidney stones with an ureteroscope configuration (stage **275**).

Method **200** may further comprise using lens-less configurations, without any distal optical elements (stage **277**) and/or using distal optical elements to control the field of view, the depth of field, implement image multiplexing and/or determine imaging parameters (stage **282**), for example by attaching or producing optical element(s) at the fiber tip (stage **280**). Method **200** may comprise enhancing the field of view and/or the depth of field of the endoscope beyond a region facing the tip of the fibers and congruent thereto (stage **285**). Method **200** may comprise configuring the optical element(s) to image void-facing areas (stage **290**), for example, using a lens with blocked aperture (stage **292**); using multiple prisms which optically communicate with the cores (stage **295**) and configuring the prisms to image void-facing areas (stage **300**), e.g., associating each prism with one or more cores (stage **305**); imaging void-facing areas using different polarization, wavelength, wavelength range and/or timing of the illumination (stage **310**), in the former using birefringent optical elements for polarization multiplexing (stage **315**).

In certain embodiments, method **200** may further comprise implementing super-resolution algorithms (on the detected radiation) to enhance resolution, field of view and/or depth of field (stage **320**).

In certain embodiments, method **200** may further comprise any of: distributing the cores irregularly (with respect to detector pixel order) over the tip cross section (stage **332**), distributing the cores at a small fill factor (stage **334**), and implementing micro-scanning of the region facing the tip (stage **336**). In certain embodiments, method **200** may comprise enhancing images by optimizing pixel focus over different tip positions (stage **338**), for example by selecting the best focus for each pixel from a plurality of images captured at different tip positions, and composing an enhanced image from the pixels at their selected best focus.

In certain embodiments, method **200** may comprise handling the cores groupwise, possibly with dynamic allocation of cores to groups, to implement wavefront sensing by each group (stage **340**). Method **200** may comprise implementing light field sensing, i.e., comparing light directions at different cores operating in near field and multi mode.

In certain embodiments, method **200** may further comprise using non-imaged wavelengths to provide additional field of view and/or depth of field information (stage **350**). Method **200** may comprise collecting diagnostic data using, possibly non-imaged, diagnostic wavelength ranges (stage **360**). In any of the embodiments, method **200** may comprise configuring the endoscope as a laparoscope or an ureteroscope (stage **370**).

Method **200** may further comprise producing the fiber from standardized fiber modules (stage **380**). In certain embodiments, method **200** comprises packaging the fiber

modules into desired fiber cross section forms or configurations (stage **382**). Method **200** may comprise modifying the spatial relations of the fiber modules along the fiber (stage **385**), e.g., to have a circumferential arrangement of fiber modules at the distal tip and a compact arrangement of fiber modules at the proximal tip of the fiber.

In certain embodiments, method **200** may further comprise applying conductive coatings to some fiber modules, with other fiber modules as insulators (stage **387**), e.g., for delivering electromagnetic energy to the fiber tip via the conductive coating, e.g., for heating the fiber tip (stage **390**), elements associated with the fiber tip and/or a surroundings of the fiber tip.

FIGS. **8A-8E** are high level schematic illustrations of experimental imaging results for bundled fibers, according to some embodiments of the invention. The imaging configuration is illustrated schematically in FIG. **1B**. The presented results represent raw data, prior to the application of the image processing algorithms described above. FIGS. **8A-8C** illustrate the imaging of three different targets using a two by two bundled fiber (as evident in the four sub-images, each received from one fiber module, having a side of **450 $\mu$ m**, and ca. 23,000 cores per fiber module). The targets are respectively a resolution target, characters (person and doll) and an anatomy model. FIG. **8D** illustrates imaging by a single multicore fiber, 1.8 mm in diameter having ca. 500,000 cores. Both configurations achieve very high resolution which is unattainable by current fibers. FIG. **8E** illustrates a result achieved by applying image enhancement algorithms applied on the captured image. It is noted that each multi-core fiber module may comprise more than 10,000 cores and may have a diameter of less than 1 mm.

In the above description, an embodiment is an example or implementation of the invention. The various appearances of “one embodiment”, “an embodiment”, “certain embodiments” or “some embodiments” do not necessarily all refer to the same embodiments.

Although various features of the invention may be described in the context of a single embodiment, the features may also be provided separately or in any suitable combination. Conversely, although the invention may be described herein in the context of separate embodiments for clarity, the invention may also be implemented in a single embodiment.

Certain embodiments of the invention may include features from different embodiments disclosed above, and certain embodiments may incorporate elements from other embodiments disclosed above. The disclosure of elements of the invention in the context of a specific embodiment is not to be taken as limiting their use in the specific embodiment alone.

Furthermore, it is to be understood that the invention can be carried out or practiced in various ways and that the invention can be implemented in certain embodiments other than the ones outlined in the description above.

The invention is not limited to those diagrams or to the corresponding descriptions. For example, flow need not move through each illustrated box or state, or in exactly the same order as illustrated and described.

Meanings of technical and scientific terms used herein are to be commonly understood as by one of ordinary skill in the art to which the invention belongs, unless otherwise defined.

While the invention has been described with respect to a limited number of embodiments, these should not be construed as limitations on the scope of the invention, but rather as exemplifications of some of the preferred embodiments. Other possible variations, modifications, and applications are also within the scope of the invention. Accordingly, the

scope of the invention should not be limited by what has been described, but by the appended claims and their legal equivalents.

The invention claimed is:

1. An endoscope having a distal tip and a proximal tip, the endoscope comprising:

at least one multi-core fiber module comprising at least one hundred cores distributed at a fill factor smaller than  $\frac{1}{4}$ ,

at least one optical element, in optical communication with the cores, at the distal tip, and

a detector, in optical communication with the cores, at the proximal tip;

wherein the endoscope is configured to implement super-resolved imaging by micro scanning over a pitch distance between the cores, and

wherein the endoscope is configured to implement three dimensional sensing by handling the cores group-wise with respect to radiation delivered therethrough, and to at least one of:

enhance, by configuring the at least one optical element, a field of view of the endoscope beyond a region facing the cores at the distal tip, and

enhance, by configuring the at least one optical element, a depth of field of the endoscope beyond a region congruent to the distal tip.

2. The endoscope of claim 1, configured to have a Young's modulus smaller than 10 GPa and to be disposable.

3. The endoscope of claim 1, wherein the at least one optical element comprises a plurality of prisms set according to specified field of view and depth of field requirements, the prisms set directly on the distal tip or on lenses attached to the distal tip.

4. The endoscope of claim 1, comprising a plurality of multi-core fiber modules which are arranged modularly in the endoscope.

5. The endoscope of claim 4, wherein each multi-core fiber module comprises more than 10,000 cores and has a diameter of less than 1 mm.

6. The endoscope of claim 4, wherein the endoscope comprises at least three multi-core fiber modules and further comprising at least two conductive coatings applied to at least two corresponding non-adjacent multi-core fiber modules, wherein the endoscope is configured to enable delivering electromagnetic energy via the conductive coatings to the distal tip for heating and defogging the distal tip.

7. The endoscope of claim 1, further comprising at least one photonic illumination fiber configured to deliver illumination to the distal tip of the endoscope, or a LED light source located at the distal tip.

8. The endoscope of claim 7, wherein the at least one photonic illumination fiber is configured to illuminate one part of the region facing the tip differently from another part of the region facing the tip, wherein the difference lies in at least one of: polarization, wavelength, wavelength range and timing of the illumination.

9. The endoscope of claim 1, further comprising at least one void going through the endoscope and configured as a working channel that enables an introduction at a distal tip of the endoscope of at least one of: at least one illumination

element, at least one treatment element and suction according to imaging input during treatment.

10. The endoscope of claim 9, wherein the at least one optical element comprises at least one of a lens having at least one blocked aperture and a plurality of prisms, configured to deliver radiation from a void-facing area to the cores, wherein the prisms are set directly on the distal tip or on one or more lens attached to the distal tip.

11. The endoscope of claim 9, configured as an urethroscope.

12. The endoscope of claim 1, wherein the cores are distributed irregularly at a cross section of the distal tip with respect to a pixel distribution of the detector.

13. The endoscope of claim 1, wherein the cores are handled group-wise to implement each group as a wavefront sensor.

14. The endoscope of claim 1, wherein a core spacing is selected to reduce crosstalk between adjacent cores below a specified threshold.

15. The endoscope of claim 1, further comprising elements that have a different refractive index from the cores.

16. The endoscope of claim 1, further configured to use at least one non-imaged wavelength range, selected to provide at least one of: extended field of view, extended depth of field and specified diagnostic data.

17. The endoscope of claim 1, configured as a laparoscope.

18. A method comprising:

configuring an endoscope from at least one multi-core fiber module comprising at least one thousand cores distributed at a fill factor smaller than  $\frac{1}{4}$ ,

implementing super-resolved imaging by micro scanning over a pitch distance between the cores,

implementing three dimensional sensing by handling the cores group-wise with respect to radiation delivered therethrough, and

configuring at least one optical element at a distal tip of the endoscope to enhance at least one of a field of view and a depth of field of the endoscope beyond a region facing a tip of the fibers and congruent thereto.

19. The method of claim 18, further comprising configuring the endoscope modularly from a plurality of the multi-core fiber modules.

20. The method of claim 18, further comprising configuring optical elements at the distal tip to provide specified field of view and depth of field requirements.

21. An endoscope having a distal tip and a proximal tip, the endoscope comprising:

a plurality of multi-core fiber modules, each comprising at least one thousand cores distributed at a fill factor smaller than  $\frac{1}{4}$ , and

a detector, in optical communication with the cores, at the proximal tip;

wherein the endoscope is configured to implement super-resolved imaging by micro scanning over a pitch distance between the cores, and three dimensional sensing by handling the cores group-wise with respect to radiation delivered therethrough, and

wherein the endoscope is configured to have a Young's modulus smaller than 10 GPa and to be disposable.

\* \* \* \* \*

专利名称(译)	多芯光纤内窥镜		
公开(公告)号	<a href="#">US9661986</a>	公开(公告)日	2017-05-30
申请号	US14/805915	申请日	2015-07-22
[标]申请(专利权)人(译)	ZSQUARE		
申请(专利权)人(译)	ZSQUARE LTD.		
当前申请(专利权)人(译)	ZSQUARE LTD.		
[标]发明人	SHAHMOON ASAF ZLOTNIK ALEX ZALEVSKY ZEEV KREMER TAL SIGAL ZIGDON DAVID		
发明人	SHAHMOON, ASAF ZLOTNIK, ALEX ZALEVSKY, ZEEV KREMER-TAL, SIGAL ZIGDON, DAVID		
IPC分类号	A61B1/00 A61B1/06 A61B1/07 G02B23/26 G02B6/04 G02B6/02		
CPC分类号	A61B1/00117 A61B1/0017 A61B1/00096 A61B1/00167 A61B1/00174 A61B1/00193 A61B1/0676 A61B1/07 G02B23/26 G02B6/02042 G02B6/04		
优先权	62/028346 2014-07-24 US 62/119832 2015-02-24 US		
其他公开文献	US20160022119A1		
外部链接	<a href="#">Espacenet</a> <a href="#">USPTO</a>		

摘要(译)

提供了内窥镜，多芯内窥镜纤维以及配置和操作方法。纤维可具有数百或数千个芯，并且可能包含工作通道和附加纤维。光纤可以在不同的光学配置下使用，以捕获远端尖端处的组织和物体的图像，并增强图像的宽范围的光学特性，例如分辨率，视场，景深，波长范围等。可以在内窥镜中实现场成像以及远场成像，并且可以利用相应的光学特征来优化成像。光学元件可以用在远端光纤尖端，或远端光纤尖端可以是无透镜的。可以实现诊断和光学治疗反馈回路，并且可以调整照明以产生全色图像，深度估计，增强的视野和/或景深，以及附加的诊断数据。

