



US008709000B2

(12) **United States Patent**  
**Madhani et al.**

(10) **Patent No.:** **US 8,709,000 B2**  
(45) **Date of Patent:** **Apr. 29, 2014**

(54) **ARTICULATED SURGICAL INSTRUMENT FOR PERFORMING MINIMALLY INVASIVE SURGERY WITH ENHANCED DEXTERITY AND SENSITIVITY**

(71) Applicant: **Intuitive Surgical Operations, Inc.**, Sunnyvale, CA (US)

(72) Inventors: **Akhil J. Madhani**, Glendale, CA (US); **J. Kenneth Salisbury**, Mountain View, CA (US)

(73) Assignee: **Intuitive Surgical Operations, Inc.**, Sunnyvale, CA (US)

(\*) Notice: Subject to any disclaimer, the term of this patent is extended or adjusted under 35 U.S.C. 154(b) by 0 days.

(21) Appl. No.: **13/721,508**

(22) Filed: **Dec. 20, 2012**

(65) **Prior Publication Data**

US 2013/0110131 A1 May 2, 2013

**Related U.S. Application Data**

(63) Continuation of application No. 12/833,766, filed on Jul. 9, 2010, now Pat. No. 8,343,141, which is a continuation of application No. 11/945,424, filed on Nov. 27, 2007, now Pat. No. 7,780,651, which is a continuation of application No. 11/243,730, filed on Oct. 4, 2005, now Pat. No. 7,316,681, which is a continuation of application No. 10/076,812, filed on Feb. 15, 2002, now Pat. No. 6,991,627, which is a continuation of application No. 09/340,946, filed on Jun. 28, 1999, now Pat. No. 6,371,952, which is a continuation of application No. 09/030,661, filed on Feb. 25, 1998, now Pat. No. 5,976,122, which is a continuation of application No. 08/857,776, filed on May 16, 1997, now Pat. No. 5,792,135.

(60) Provisional application No. 60/017,981, filed on May 20, 1996.

(51) **Int. Cl.**  
**A61B 17/00** (2006.01)  
**B25J 17/02** (2006.01)

(52) **U.S. Cl.**  
USPC ..... **606/1**; 74/490.05; 74/490.06

(58) **Field of Classification Search**  
CPC ..... **A61B 17/00234**; **A61B 19/22**  
USPC ..... **606/1**, **130**; **74/490.05**, **490.06**, **469**, **74/479.01**; **318/568.22**  
See application file for complete search history.

(56) **References Cited**

**U.S. PATENT DOCUMENTS**

1,620,828 A 3/1927 Molony  
4,259,876 A 4/1981 Belyanin et al.

(Continued)

**FOREIGN PATENT DOCUMENTS**

JP 7194610 8/1995  
WO 9729690 8/1997  
WO 0067640 11/2000

**OTHER PUBLICATIONS**

Alexander, Arthur D. III, "Impacts of Telemation on Modern Society;" Symposium on Theory and Practice of Robots and Manipulators, Centre for Mechanical Sciences 1st CISM IFToMM Symposium, Sep. 5-8, 1974, pp. 121-136, vol. 2, Springer-Verlag.

(Continued)

*Primary Examiner* — Julian W Woo

(57) **ABSTRACT**

An articulated surgical instrument for enhancing the performance of minimally invasive surgical procedures. The instrument has a high degree of dexterity, low friction, low inertia and good force reflection. A unique cable and pulley drive system operates to reduce friction and enhance force reflection. A unique wrist mechanism operates to enhance surgical dexterity compared to standard laparoscopic instruments. The system is optimized to reduce the number of actuators required and thus produce a fully functional articulated surgical instrument of minimum size.

**10 Claims, 8 Drawing Sheets**

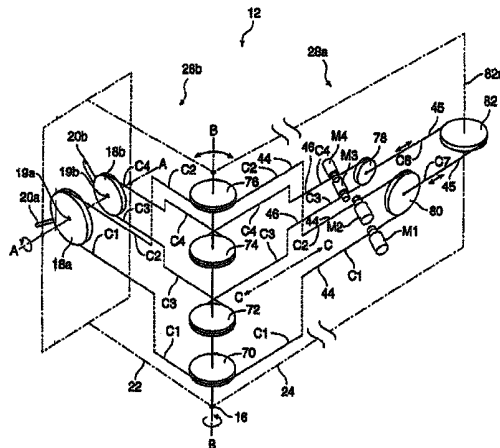

(56)

## References Cited

## U.S. PATENT DOCUMENTS

4,686,866	A *	8/1987	Rosheim .....	74/490.06
4,762,455	A	8/1988	Coughlan et al.	
4,804,220	A *	2/1989	Rosheim .....	74/479.01
4,806,066	A *	2/1989	Rhodes et al. ....	74/469
4,921,393	A	5/1990	Andeen et al.	
5,046,375	A	9/1991	Salisbury, Jr.	
5,078,140	A	1/1992	Kwoh	
5,178,032	A	1/1993	Zona et al.	
5,209,747	A	5/1993	Knoepfler	
5,217,003	A	6/1993	Wilk	
5,254,130	A	10/1993	Poncet et al.	
5,312,399	A	5/1994	Hakky et al.	
5,313,962	A	5/1994	Obenchain	
5,339,799	A	8/1994	Kami et al.	
5,368,015	A	11/1994	Wilk	
5,374,277	A	12/1994	Hassler	
5,417,210	A	5/1995	Funda et al.	
5,441,494	A	8/1995	Ortiz	
5,443,494	A	8/1995	Paolizzi et al.	
5,454,827	A	10/1995	Aust et al.	
5,456,684	A	10/1995	Schmidt et al.	
5,528,955	A	6/1996	Hannaford et al.	
5,529,955	A	6/1996	Hibino et al.	
5,556,401	A	9/1996	Caillouette	
5,558,668	A	9/1996	Lankford et al.	
5,581,166	A *	12/1996	Eismann et al. ....	318/568.22
5,626,595	A	5/1997	Sklar et al.	
5,630,431	A	5/1997	Taylor	
5,710,870	A	1/1998	Ohm et al.	
5,762,458	A	6/1998	Wang et al.	
5,784,542	A	7/1998	Ohm et al.	
5,792,135	A	8/1998	Madhani et al.	
5,800,423	A	9/1998	Jensen	
5,808,665	A	9/1998	Green	
5,814,038	A	9/1998	Jensen et al.	
5,855,583	A	1/1999	Wang et al.	
5,876,325	A	3/1999	Mizuno et al.	
5,976,122	A	11/1999	Madhani et al.	
6,223,100	B1	4/2001	Green	
6,371,952	B1	4/2002	Madhani et al.	

6,889,116	B2	5/2005	Jinno
6,991,627	B2	1/2006	Madhani et al.
7,101,363	B2	9/2006	Nishizawa et al.
7,316,681	B2	1/2008	Madhani et al.
7,780,651	B2	8/2010	Madhani et al.
7,854,738	B2	12/2010	Lee et al.
8,343,141	B2	1/2013	Madhani et al.
2006/0100610	A1	5/2006	Wallace et al.

## OTHER PUBLICATIONS

- Bejczy, Antal K. et al., "Controlling Remote Manipulators through Kinesthetic Coupling," *Computers in Mechanical Engineering*, 1983, pp. 48-60, vol. 1—Issue 1.
- Fukuda, Toshio et al., "Micro Active Catheter System With Multi Degrees of Freedom," *Proc. IEEE International Conference on Robotics and Automation*, 1994, pp. 2290-2295, vol. 3, IEEE.
- International Search Report for application No. PCT/US97/08379, Mailed on Aug. 5, 1997, 1 page.
- Neisius B. et al., "Robotic manipulator for endoscopic handling of surgical effectors and cameras," 1st Intl. Symposium on Medical Robotics and Computer Assisted Surgery, 1994, pp. 169-176, vol. 2.
- Neisius, B. et al., "Robotic Telemanipulator for Laparoscopy," Annual International Conference of the IEEE Engineering in Medicine and Biology, 1995, and Canadian Medical and Biological Engineering Conference, Sep. 20-23, 1995, pp. 1199-1200, vol. 17, No. 2, pp. 1199-1200.
- Rosheim, Mark E., Chapter 5: "Pitch-Yaw-Roll Wrists," *Robot Wrist Actuators*, Wiley & Sons, New York, 1989, pp. 95-206.
- Schenker, Paul S. et al., "Development of a Telemanipulator for Dexterity Enhanced Microsurgery," 2nd Annual International Symposium on Medical Robotics and Computer Assisted Surgery, Nov. 4-7, Baltimore, Maryland, 1995, pp. 81-88.
- Taubes, Gary et al., "Surgery in Cyberspace," *Discover magazine*, Dec. 1994, vol. 15, issue 12, pp. 85-92.
- Vertut, Jean and Phillippe Coiffet, *Robot Technology: Teleoperation and Robotics Evolution and Development*, English translation, Prentice-Hall, Inc., Englewood Cliffs, NJ, USA 1986, vol. 3A, 332 pages.

\* cited by examiner

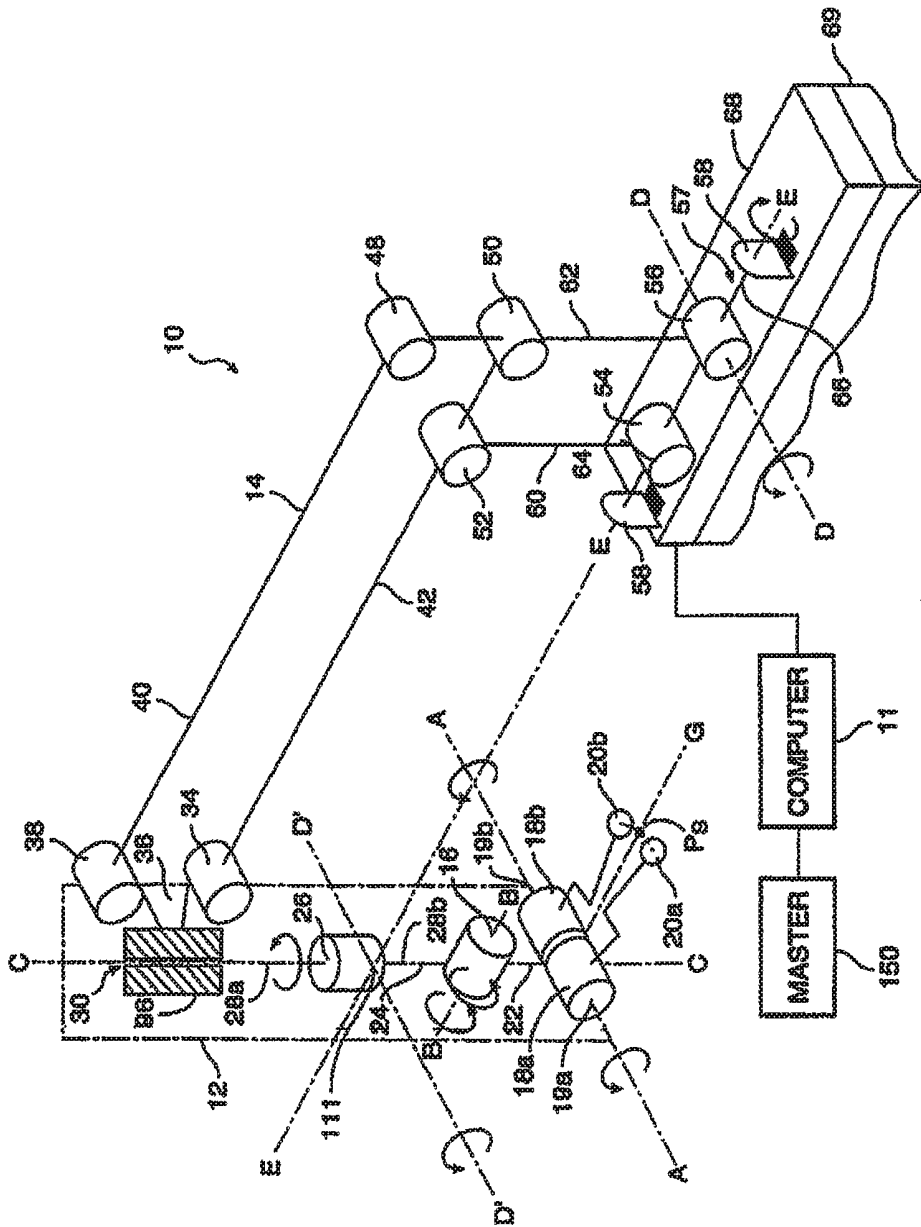

FIG. 1

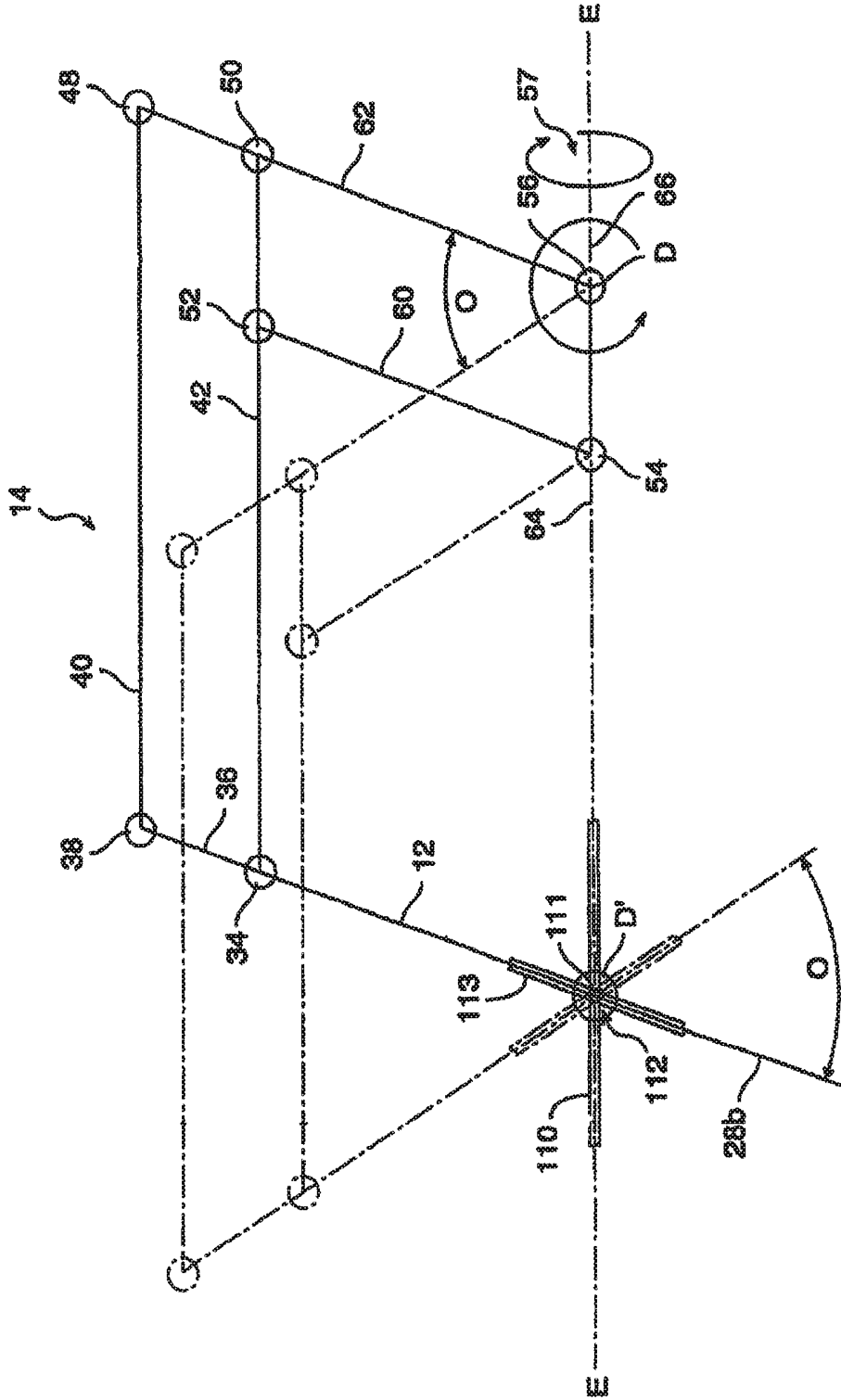

FIG. 2

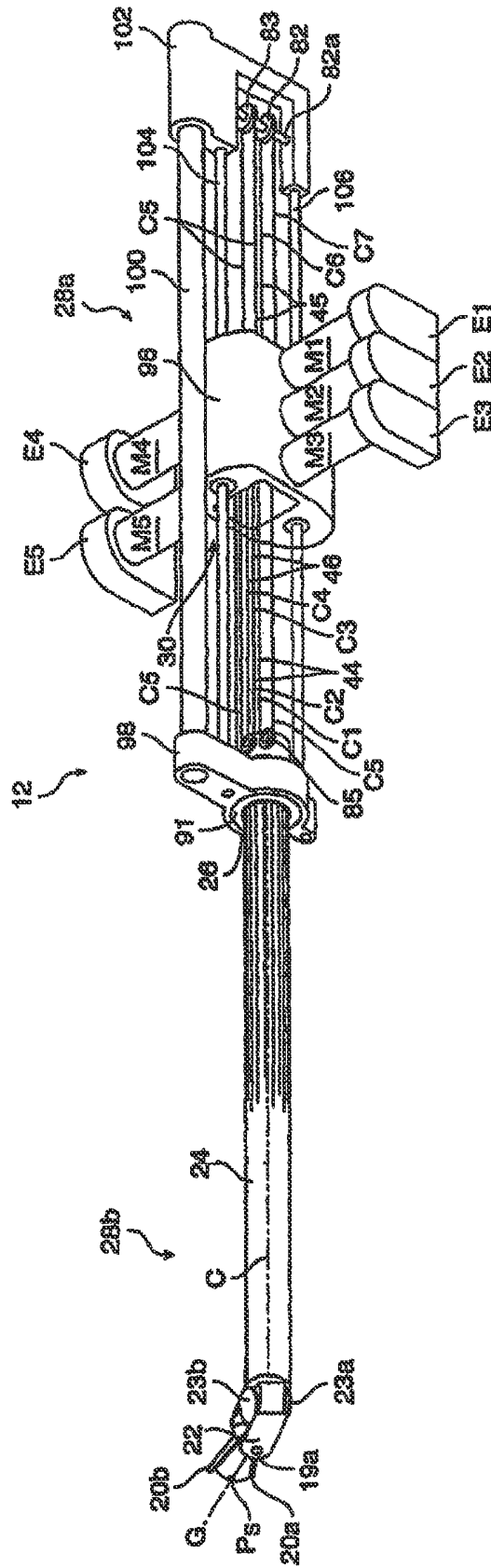

FIG. 3

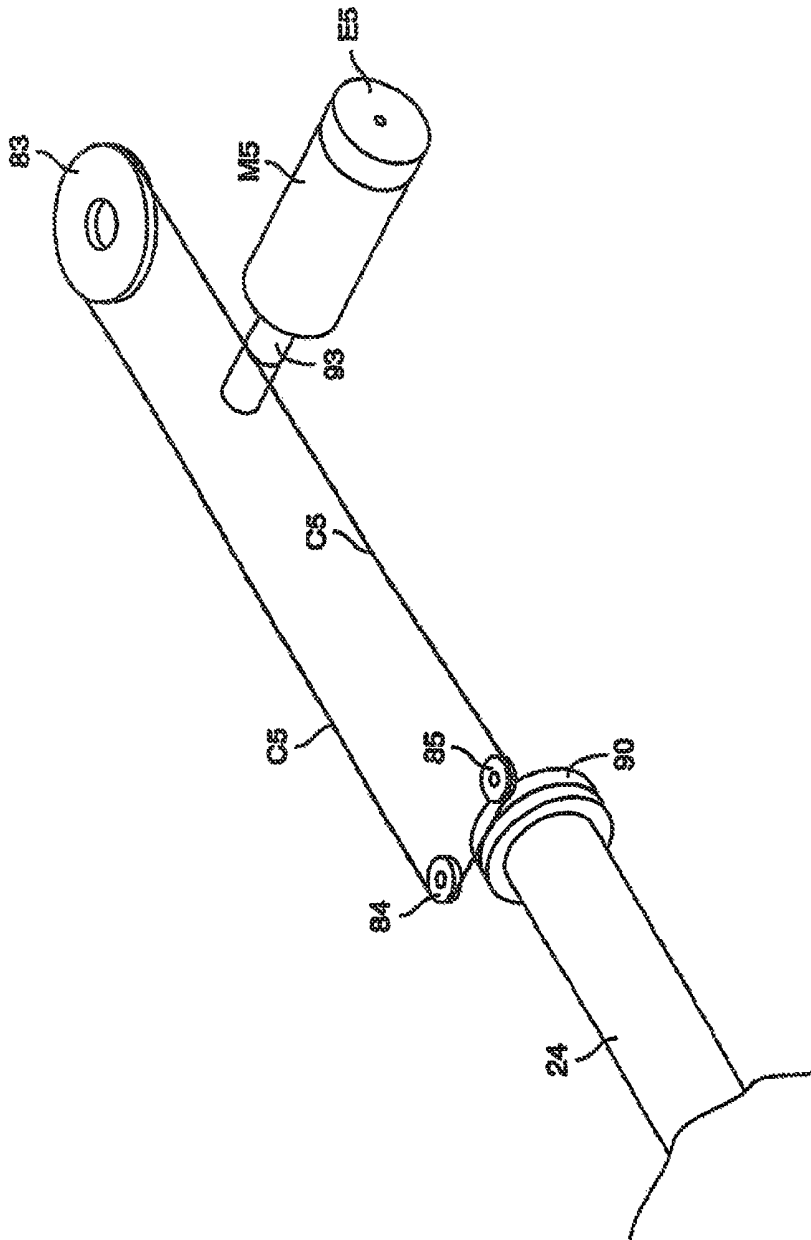

FIG. 4

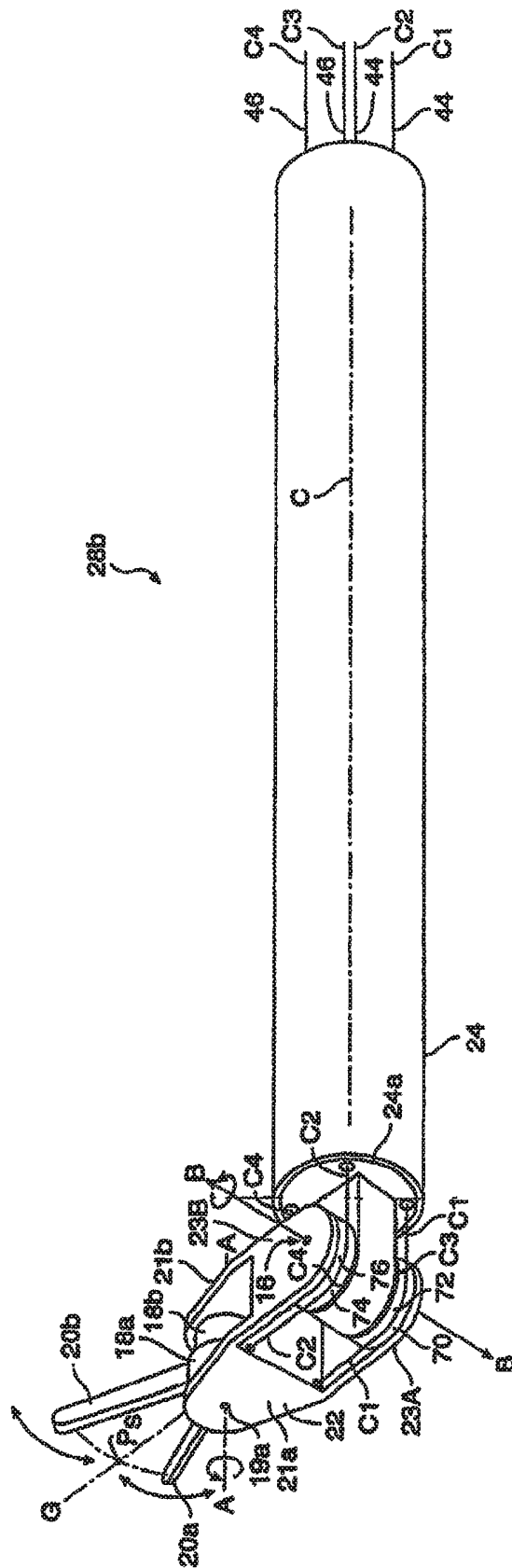

FIG. 5

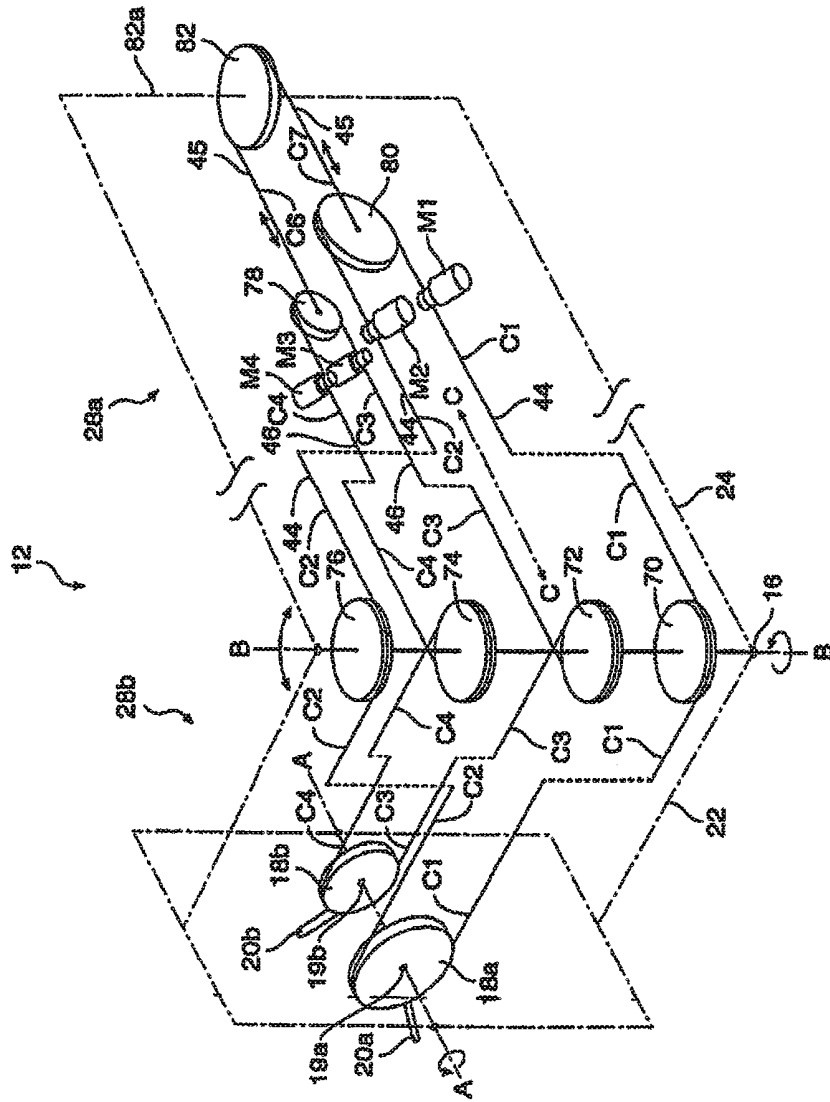

FIG. 6



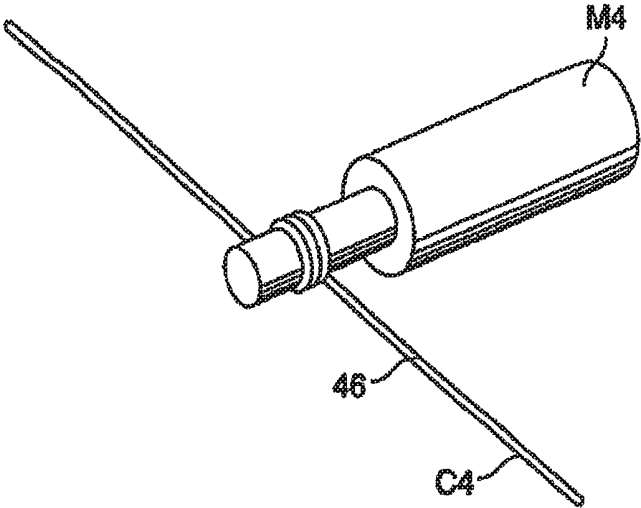

FIG. 7A

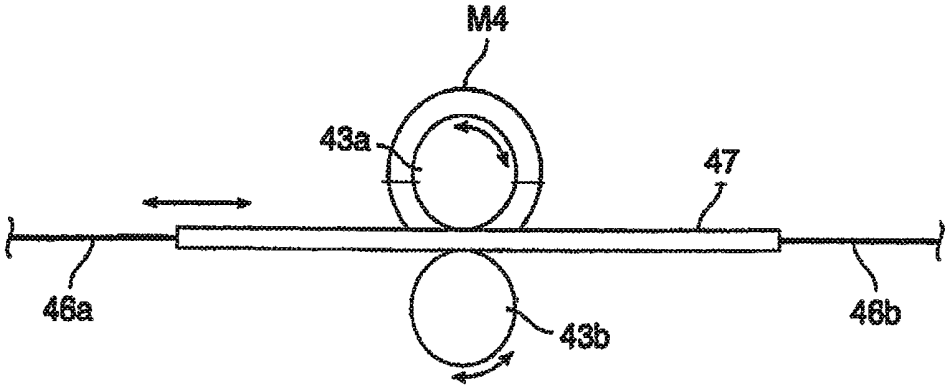

FIG. 7B

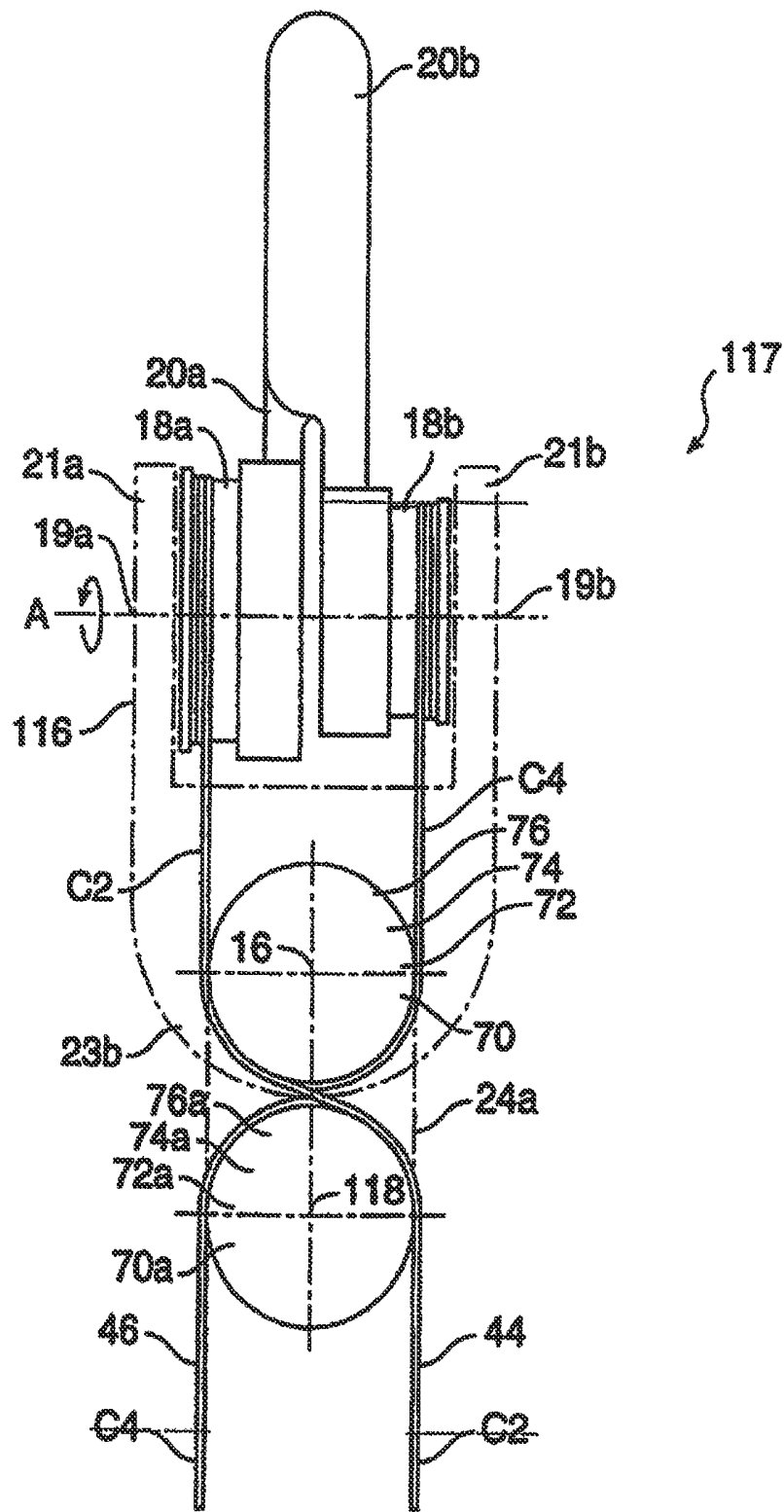

FIG. 8

**ARTICULATED SURGICAL INSTRUMENT  
FOR PERFORMING MINIMALLY INVASIVE  
SURGERY WITH ENHANCED DEXTERITY  
AND SENSITIVITY**

This application is a continuation of, and claims the benefit of priority from, co-pending U.S. patent application Ser. No. 10/076,812, filed Feb. 15, 2002, which is a continuation of Ser. No. 09/340,946, filed Jun. 28, 1999, which is a continuation of U.S. patent application Ser. No. 09/030,661, filed Feb. 25, 1998 (now U.S. Pat. No. 5,976,122), which is a continuation of U.S. patent application Ser. No. 08/857,776, filed May 16, 1997 (now U.S. Pat. No. 5,792,135), which claims priority to U.S. Provisional Application No. 60/017,981, filed May 20, 1996, the full disclosures of which are incorporated herein by reference.

**FIELD OF THE INVENTION**

This invention relates generally to methods and apparatus for enhancing the performance of minimally invasive surgery. This invention relates particularly to surgical instruments that augment a surgeon's ability to perform minimally invasive surgical procedures. This invention relates more particularly to a novel articulated surgical instrument for minimally invasive surgery which provides a high degree of dexterity, low friction, low inertia and good force reflection.

**BACKGROUND OF THE INVENTION**

Minimally invasive medical techniques are aimed at reducing the amount of extraneous tissue which must be damaged during diagnostic or surgical procedures, thereby reducing patient recovery time, discomfort, and deleterious side effects. Approximately 21,000,000 surgeries are now performed each year in the United States. It is estimated that 8,000,000 of these surgeries can potentially be performed in a minimally invasive manner. However, only about 1,000,000 surgeries currently use these techniques due to limitations in minimally invasive surgical instruments and techniques and the additional surgical training required to master them.

Advances in minimally invasive surgical technology could have a dramatic impact. The average length of a hospital stay for a standard surgery is 8 days, while the average length for the equivalent minimally invasive surgery is 4 days. Thus, the complete adoption of minimally invasive techniques could save 28,000,000 hospital days, and billions of dollars annually in hospital residency costs alone. Patient recovery times, patient discomfort, surgical side effects, and time away from work are also reduced with minimally invasive surgery.

The most common form of minimally invasive surgery is endoscopy. Probably the most common form of endoscopy is laparoscopy which is minimally-invasive inspection and surgery inside the abdominal cavity. In standard laparoscopic surgery, a patient's abdomen is insufflated with gas, and cannula sleeves are passed through small (approximately 1/2 inch) incisions to provide entry ports for laparoscopic surgical instruments.

The laparoscopic surgical instruments generally include a laparoscope for viewing the surgical field, and working tools such as clamps, graspers, scissors, staplers, and needle holders. The working tools are similar to those used in conventional (open) surgery, except that the working end of each tool is separated from its handle by an approximately 12-inch long extension tube.

To perform surgical procedures, the surgeon passes instruments through the cannula and manipulates them inside the

abdomen by sliding them in and out through the cannula, rotating them in the cannula, levering (i.e., pivoting) the instruments in the abdominal wall and actuating end effectors on the distal end of the instruments. The instruments pivot around centers of rotation approximately defined by the incisions in the muscles of the abdominal wall. The surgeon monitors the procedure by means of a television monitor which displays the abdominal worksite image provided by the laparoscopic camera.

Similar endoscopic techniques are employed in arthroscopy, retroperitoneoscopy, pelviscopy, nephroscopy, cystoscopy, cisternoscopia, sinoscopy, hysteroscopy and urethroscopy. The common feature of all of these minimally invasive surgical techniques is that they visualize a worksite within the human body and pass specially designed surgical instruments through natural orifices or small incisions to the worksite to manipulate human tissues and organs thus avoiding the collateral trauma caused to surrounding tissues which would result from creating open surgical access.

There are many disadvantages of current minimally invasive surgical technology. For example, existing MIS instruments deny the surgeon the flexibility of tool placement found in open surgery. Most laparoscopic tools have rigid shafts and are constrained to approach the worksite from the direction of the small incision. Additionally, the length and construction of many endoscopic instruments reduces the surgeon's ability to feel forces exerted by tissues and organs on the end effector of the tool. The lack of dexterity and sensitivity provided by endoscopic tools is a major impediment to the expansion of minimally invasive surgery.

Telesurgery systems for use in surgery are being developed to increase a surgeon's dexterity as well as to allow a surgeon to operate on a patient from a remote location. Telesurgery is a general term for surgical systems where the surgeon uses some form of servomechanism to manipulate the surgical instruments movements rather than directly holding and moving the tools. In a system for telesurgery, the surgeon is provided with an image of the patient's body at the remote location. While viewing the three-dimensional image, the surgeon performs the surgical procedures on the patient by manipulating a master device which controls the motion of a servomechanism-actuated instrument. The surgeon's hands and the master device are positioned relative to the image of the operation site in the same orientation as the instrument is positioned relative to the act. During the operation, the instrument provides mechanical actuation and control of a variety of surgical instruments, such as tissue graspers, needle drivers, etc., that each perform various functions for the surgeon, i.e., holding or driving a needle, grasping a blood vessel or dissecting tissue.

Such telesurgery systems have been proposed for both open and endoscopic procedures. An overview of the state of the art with respect to telesurgery technology can be found in "Computer Integrated Surgery: Technology And Clinical Applications" (MIT Press, 1996). Moreover, prior systems for telesurgery are described in U.S. Pat. Nos. 5,417,210, 5,402,801, 5,397,323, 5,445,166, 5,279,309, 5,299,288.

However methods of performing telesurgery using telemanipulators still require the development of dexterous surgical instruments capable of transmitting position, force, and tactile sensations from the surgical instrument back to the surgeon's hands as he/she operates the telesurgery system such that the system the surgeon has the same feeling as if manipulating the surgical instruments directly by hand. A system's ability to provide force reflection is limited by factors such as

friction within the mechanisms, gravity, the inertia of the surgical instrument and forces exerted on the instrument at the surgical incision.

What is needed, therefore, is a surgical instrument that increases the dexterity with which a surgeon can perform minimally invasive surgical procedures.

It would also be desirable to provide a dexterous surgical apparatus having a wrist with two degrees-of-freedom.

It would further be desirable to provide a wrist mechanism that has low friction in order to provide the surgeon with sensitive feedback of forces exerted on the surgical instrument.

It would still further be desirable to provide a surgical instrument having a wrist mechanism for minimally invasive surgery which is suitable for operation in a telemanipulator mechanism.

### SUMMARY AND OBJECTS OF THE INVENTION

Accordingly, it is an object of this invention to provide a surgical instrument that increases the dexterity with which a surgeon can perform minimally invasive surgical procedures.

It is also an object of this invention to provide a dexterous surgical apparatus having a wrist with two degrees-of-freedom.

It is a further object of this invention to provide a wrist mechanism that has low friction in order to provide the surgeon with sensitive feedback of forces exerted on the surgical instrument.

It is a still further object of this invention to provide a surgical instrument having a wrist mechanism for minimally invasive surgery which is suitable for, operation in a telemanipulator mechanism.

In accordance with the above objects of the invention applicants describe a compact articulated surgical instrument suitable for endoscopic surgery. The instrument has two opposed pivoting jaws and a pivoting wrist member. The instrument is capable of providing force reflection with high sensitivity. The instrument is adapted to be coupled via a servomechanism to a master control operated by a surgeon.

### BRIEF DESCRIPTION OF THE DRAWINGS

The foregoing and other objects, features and advantages of the invention will be apparent from the following more particular description of preferred embodiments of the drawings in which like reference characters refer to the same parts throughout the different views. The drawings are not necessarily to scale, emphasis instead being placed upon illustrating the principles of the invention.

FIG. 1 is a schematic drawing of a servomechanical surgery system including a force-reflecting surgical instrument mounted to a positioning mechanism.

FIG. 2 is a schematic drawing of a positioning mechanism in forward and rearward positions with the surgical instrument inserted into a patient.

FIG. 3 is a perspective view of a force-reflecting surgical instrument.

FIG. 4 is a schematic view of the cable drive actuation of the rotary motion of the force-reflecting surgical instrument.

FIG. 5 is a perspective view of the distal end of the force-reflecting surgical instrument.

FIG. 6 is a simplified schematic drawing of the force-reflecting surgical instrument showing the relationship of the cables and pulleys.

FIG. 7a is a perspective view of a cable wrapped around the drive shaft of a drive motor.

FIG. 7b is a schematic drawing showing another preferred method for driving the cables in the present invention.

FIG. 8 is a top view of the wrist member of another preferred force-reflecting surgical instrument.

### DETAILED DESCRIPTION OF THE PREFERRED EMBODIMENTS

The surgical instrument in the first embodiment includes an elongate support member having a proximal portion and a distal portion lying along a longitudinal axis. A distal wrist member is rotatably coupled to the distal portion of the support member by a wrist joint. First and second opposed work members are mounted to respective first and second driven capstans. The first and second driven capstans are rotatably mounted to the wrist member by respective first and second capstan joints which preferably have a common axis. First, second, third and fourth intermediate idler pulleys are rotatably mounted to the wrist member about the wrist joint. A cable drive system including first, second, third and fourth cables is provided. Each intermediate idler pulley is engaged by one cable and each driven capstan is drivingly engaged by two cables. The cable drive system is capable of pivoting the wrist member about the wrist joint and pivoting the work members independently of each other about the capstan joints.

In preferred embodiments, a linear bearing is mounted in sliding engagement with the support member for allowing the distal portion of the support member to be reciprocated along the longitudinal axis relative to the proximal portion of the support member. In such embodiments the cable drive system is capable of translating the support member along the longitudinal axis. In preferred embodiments, the support member may also include a rotary joint separating the proximal and distal portions of the support member for allowing rotation of the distal portion relative to the proximal portion about the longitudinal axis. In such embodiments the first through fourth cables are capable of twisting about the longitudinal axis during rotation of the distal portion and the cable drive system comprises a fifth cable coupled to the rotary joint for rotating the distal portion about the longitudinal axis.

The present invention also provides a novel system for tensioning the first, second, third and fourth cables. A first proximal idler pulley rotatably engages and tensions the first and second cables. A second proximal idler pulley rotatably engages and tensions the third and fourth cables. Fifth and sixth cables are connected to the first and second proximal idler pulleys for tensioning the first and second proximal idler pulleys. A third more proximal idler pulley is rotatably mounted to a support member for rotatably engaging and tensioning the fifth and sixth cables.

The surgical instrument further includes a plurality of actuators, each for driving one of the cables of the cable drive system. The instrument preferably comprises one actuator for each degree-of-freedom of the instrument. The actuators are preferably servomotors which are positioned between the intermediate idler pulleys and the proximal idler pulleys. The servomotors are preferably directly coupled to the cables by means of a drive capstan mounted on the drive shaft of the servomotor.

The surgical instrument is adapted to be a slave device which is controlled by a master device and a controller. Movements of the instrument and the master device as well as forces exerted thereon may be scaled between the instrument and the master device. A positioning mechanism having two

degrees-of-freedom may be mounted to the instrument for positioning the instrument over a work site. The positioning mechanism may provide the instrument with redundant degrees-of-freedom for positioning the endpoint. The combination of a positioning mechanism with the applicants articulated surgical instrument is adapted to enable a surgeon operating the master device to feel forces that are experienced by the instrument during positioning and use of the instrument with greater sensitivity than with prior systems.

Details about the preferred attributes of the surgical system are also described in applicants' pending applications titled "Force-Reflecting Surgical Instrument And Positioning Mechanism For Performing Minimally Invasive Surgery With Enhanced Dexterity And Sensitivity" and "Wrist Mechanism For Surgical Instrument For Performing Minimally Invasive Surgery With Enhanced Dexterity And Sensitivity" filed on even date herewith. The disclosures of these applications are incorporated herein by reference.

Referring to FIG. 1, telesurgery system 10 allows a surgeon at one location to perform surgery on a patient at another location. The surgeon may be in the same operating room as the patient or many miles away. Telesurgery system 10 includes a force-reflecting surgical instrument 12 which is mounted by a bracket 36 to a positioning mechanism 14. Instrument 12 and positioning mechanism 14 are controlled by a computer 11 and a master device 150 which is manipulated by a surgeon at a remote location. Instrument 12 and positioning mechanism 14 are driven by drive motors M1, M2, M3, M4, M5, M6 and M7 (FIGS. 3, 4, 6 and 7a-b) in conjunction with a series of cables and pulleys.

Instrument 12 has low friction, low inertia and high bandwidth but a small range of motion. Positioning mechanism 14 has a large range of motion but typically has a higher inertia and a lower bandwidth than the instrument. The combination of instrument 12 and positioning mechanism 14 in a macro/micro actuation scheme results in a system with increased dynamic range compared to either of its individual components. Positioning mechanism 14 provides telesurgery system 10 with redundant degrees-of-freedom and helps position instrument 12 at a surgical worksite so that instrument 12 is generally in the proper location for performing the necessary surgery. Thus, by mounting instrument 12 on positioning mechanism 14, telesurgery system 10 is provided with high quality force control through the use of instrument 12 while at the same time having a large range of motion due to positioning mechanism 14. Instrument 12 is mounted on positioning mechanism 14 by means of mounting bracket 36. Preferably, the Instrument 12 is releasably attached to positioning mechanism 14 using any suitable releasable attachment means such as screws, bolts, clamps.

Instrument 12 has a proximal portion 28a which is rotatably coupled to a distal portion 28b by a rotary joint 26. Proximal portion 28a is slidably coupled to a sliding bracket 96 which forms a sliding joint 30. Sliding bracket 96 is fixed to bracket 36. Bracket 36 is a mounting bracket which releasably connects instrument 12 to positioning mechanism 14. Distal portion 28b of instrument 12 includes a wrist member which is rotatably coupled to a tubular support member 24 by a wrist joint 16. Two opposed work members 20a and 20b are fixed to respective driven capstans 18a and 18b which are rotatably coupled to wrist member 22 about capstan joints 19a and 19b. The work members 20a and 20b can be the operative end of standard surgical instruments such as scissors, retractors, needle drivers and electrocautery instruments.

Instrument 12 has five degrees-of-freedom with sliding joint 30 providing linear motion along longitudinal axis C-C,

rotary joint 26 providing rotational motion about axis C-C, wrist joint 16 providing rotational motion about axis B-B and capstan joints 19a and 19b providing rotational motion about axis A-A for work members 20a and 20b. Instrument 12 provides master device 150 with four degrees of force reflection so that the surgeon can have tactile feedback of surgical procedures. These degrees of force reflection include x, y and z forces exerted on the work members 20a and 20b, as well as the holding force between work members 20a and 20b. However, force reflection can be provided on more or fewer motion axes as required in any particular embodiment.

Positioning mechanism 14 is a two degree-of-freedom linkage which is preferably a four bar linkage which rotates about an axis E-E. Positioning mechanism 14 has a series of rigid members 36, 40, 42, 60 and 62 which are joined together by joints 34, 38, 48, 50, 52, 54, 56. Positioning mechanism 14 also includes a base 68 having ears 58 which engage shafts 64 and 66 to form a joint 57 for pivoting about axis E-E. Joint 56 allows link 62 to rotate about axis D-D which is orthogonal to axis E-E. The four bar linkage of rigid members 36, 40, 42, 60 and 62 transmits this rotation to instrument 12 via bracket 36 causing instrument 12 to rotate about axis E-E and axis D'-D' (axis D'-D' is parallel to axis D-D and intersects axis E-E orthogonally). Thus the four bar linkage operates to move point P.sub.s of instrument 12 about the surface of a sphere having its center at a remote center 111. Although a four bar linkage has been shown, the articulated surgical instrument of the present invention can be supported by any suitable positioning mechanism. To be suitable for minimally invasive surgery the positioning mechanism must pivot the surgical instrument about axes that intersect at the orifice through which the instrument is inserted into the patient.

Haptic master device 150 suitable to control instrument 12 is a seven degree-of-freedom input device. During use the master 150 is fixed in place to a console or cart or similar stationary support such that the mount provides a fixed reference point. During use, the surgeon manipulates the position and orientation of the master mechanism relative to its stationary support. Linkages, motors and encoders of the master detect the surgeon's movements and transmit them to the computer. The motors of the master preferably also provide force feedback to the surgeon. This controls motions of instrument 12 and positioning mechanism 14 and thus controls the position of the distal end of instrument 12 relative to the surgical site.

One apparatus suitable for use as a master in the presently described system is described in U.S. Pat. No. 5,587,937, titled Force Reflecting Haptic Interface the contents of which are incorporated by reference herein. Another suitable master device is described in U.S. Pat. No. 5,576,727, titled Electro-mechanical Human-Computer Interface With Force-Feedback the contents of which are incorporated by reference herein. The haptic master apparatus disclosed in the above references would require the addition of a further powered degree-of-freedom to provide force reflection from gripping the work members. For example, finger grippers may be attached to a motor and encoder on a separate mechanism for operation by the other hand of the surgeon. Alternatively, finger grippers may be attached to a motor and encoder on the same device for operation by the surgeon.

When employing telesurgery system 10 for laparoscopic surgery, positioning mechanism 14 is mounted to a manually-operated setup joint (not shown). After the setup joint has been used to position the tool and lock the tool in place, the surgeon then manipulates master device 150 to move instrument 12 through a cannula 113 inserted through small incision 112 in the abdominal wall 110 of the patient. In response

to manipulation of master device **150**, the distal portion **28b** of the instrument **12** is translated downwardly relative to positioning mechanism **14** along sliding joint **30** for insertion through cannula **113** and abdominal wall **110**.

Once within the abdomen, the distal portion **28b** of instrument **12** is further positioned over the desired surgical site. FIG. 2 depicts motion of mechanism **14** pivoted about axis D-D in forward and rearward positions for making large position movements. Positioning mechanism **14** pivots about axes D-D and E-E to perform large movements of telesurgery system **10** while precise movements are made by the joints of instrument **12**. Point **111** on instrument **12** is a remote point of rotation from positioning mechanism **14** which coincides with entry wound **112**. When positioning mechanism **14** is pivoted about axes D and E, instrument **12** pivots about point **111**. Note that point **111** adjacent incision **112** remains stationary as the instrument **12** is pivoted within the patient. As a result, incision **112** only needs to be large enough to accept instrument **12**.

As positioning mechanism **14** pivots, if wrist member **22** or work members **20a/20b** engage tissue causing rotation about joints **16** or **19a/19b**, instrument **12** will reorient itself so that instrument **12** is maintained relative to positioning mechanism **14** in the middle of its workspace. If necessary, positioning mechanism **14** can slow down as instrument **12** is reorienting itself.

Once instrument **12** is in the proper position, by further manipulating master device **150**, the surgeon can perform the necessary surgical procedures on the patient with instrument **12**. Forces experienced by instrument **12** are reflected back to the surgeon by master device **150**. The reflected forces may be scaled up in order to allow the surgeon to better “feel” the surgical procedures. As a result, the surgeon can feel instrument **12** engaging types of tissue that do not provide much resistance. In addition, movements of master device **150** relative to instrument **12** may be scaled down so that the precision and dexterity of instrument **12** can be increased.

Positioning mechanism **14**, because it is optimized to have a large range of motion, is likely to have higher inertia, higher friction and lower resolution than instrument **12**. Moreover, friction forces in cannula **113** and disturbance forces at incision **112** may be applied to the positioning mechanism.

However, in applicants’ preferred embodiment, primarily the surgical instrument detects forces for force reflection. Therefore, the higher inertia and friction of the positioning mechanism and the extraneous forces acting on it are excluded from the force reflection system. Thus, the quality of the force reflection between the tip of the instrument **12** and the master device is greatly improved.

Referring to FIGS. 3, 4 and 5, instrument **12** is now described in greater detail. Tubular support member **24** of distal portion lies along axis C-C and houses a series of cables C1, C2, C3 and C4 which travel the length of tubular support member **24**. Cables C1, C2, C3 and C4 control the rotation of joints **19a**, **19b** and **16** for controlling the operation of work members **20a** and **20b** and the orientation of wrist member **22**. Wrist member **22** includes two opposed distal ears **21a** and **21b** forming a clevis for supporting driven capstans **18a** and **18b** at respective capstan joints **19a** and **19b** which lie along axis A-A. Wrist member **22** also includes two opposed proximal ears **23a** and **23b** forming a clevis for supporting intermediate idler pulleys **70** and **72** which lie along axis B-B between ear **23a** and tongue **24a** at wrist joint **16**. Intermediate idler pulleys **74** and **76** are supported between ear **23b** and tongue **24a**. Cables C1, C2, C3 and C4 engage driven capstans **18a/18b** as well as intermediate idler pulleys **70**, **72**, **74** and **76** as described later in greater detail.

Work members **20a** and **20b** may be removably fixed to respective driven capstans **18a** and **18b**. Although work members **20a** and **20b** are depicted in the figures as being grippers, work members **20a** and **20b** can be replaced with other types of work members such as scissors, cutters, graspers, forceps or needle holders for stitching sutures. Typically, the work members are fixed to driven capstans **18a** and **18b** by a screw, clip or other suitable fastener. However, the work members may also be permanently affixed to the driven capstans by soldering or welding or the like or may be formed in one piece with the driven capstans.

Work members **20a** and **20b** together comprise one form of surgical end effector. Other surgical end effectors may be used in the surgical instrument of the present invention. End effectors simply may comprise standard surgical or endoscopic instruments with their handles removed including, for example, retractors, electrocautery instruments, microforceps, microneedle holders, dissecting scissors, blades, irrigators, and sutures. The end effectors will typically comprise one or two work members.

Proximal portion **28a** of instrument **12** includes support brackets **98** and **102** which are connected together by a support rod **100** as well as two guide rails **104** and **106**. A rotary bearing **91** forming rotary joint **26** is housed within support bracket **98** for supporting tubular support member **24**. Sliding bracket **96** is slidably mounted to guide rails **104** and **106** along linear bearings. As shown in FIG. 1, sliding bracket **96** is connected by bracket **36** to positioning mechanism **14**. Sliding bracket **96** preferably has about 8 inches of travel for surgical applications.

Drive motors M1, M2, M3, M4 and M5 are mounted to sliding bracket **96** and drive respective cables C1, C2, C3 and C4 and C5. Sliding bracket **96** supports each of the drive motors. During operation sliding bracket **96** is connected to positioning mechanism **14** by mounting bracket **36**. When instrument **12** is mounted on positioning mechanism **14**, the drive motors operate to move distal portion **28b** relative to sliding bracket **96**. Sliding bracket **96** thus forms the support bracket of the surgical instrument. Each drive motor M1, M2, M3, M4 and M5 includes a respective encoder E1, E2, E3, E4 and E5 for providing computer **11** with the rotational position of their respective drive shafts.

As shown in FIG. 4, drive motor M5 has a drive shaft capstan **93** which engages a cable drive loop consisting of Cable C5. The cable passes around rear tensioning pulley **83**. The cable passes around idler pulleys **84** and **85** and around drive capstan **90** which forms the proximal end of tubular support member **24**. Thus rotation of actuation of motor M5 can be used to rotate tubular support member **24** and the end effector it supports.

Referring to FIG. 6, the cable drive system of instrument **12** is now described in greater detail. Work members **20a** and **20b**, wrist member **22** and the translation of instrument **12** along longitudinal axis C-C are driven by cables C1, C2, C3 and C4 which are arranged in an N+1 actuation scheme. The N+1 actuation scheme allows the actuation of a three degree-of-freedom wrist using four cables. Four cables is the theoretical minimum possible number of tension elements required to drive three degrees-of-freedom and thus allows the instrument to be of minimum size and weight. Alternative actuation schemes using more cables may be desirable in situations where the forces required for actuation of different motions differ greatly in magnitude. The disadvantage of using more cables is an increase in weight, complexity and minimum size.

In FIG. 6, the rotational motion of joint **26** about axis C-C is omitted in order to more easily show cables C1-C4. Such

rotation results only in twisting of the cables C1-C4 between motors M1-M4 and pulleys 70, 72, 74 and 76. The cables are however arranged in tubular support member 24 such that this twisting does not significantly change the length of the cable path. Care should however be taken to prevent over-rotation of the instrument which would cause the cables to twist into contact with each other and create friction between the cables.

As shown in FIG. 6, cables C1 and C2 form two sides of a continuous cable loop 44. Cable C1 of loop 44 engages a proximal idler pulley 80, the drive shaft of motor M1, intermediate idler pulley 70 and driven capstan 18a. Cable loop 44 returns from driven capstan 18a as cable C2 and engages intermediate idler pulley 76, the drive shaft of motor M2 and proximal idler pulley 80.

As shown in FIG. 6, cables C3 and C4 form two sides of a continuous loop of cable 46. Cable C3 of cable loop 46 engages proximal idler pulley 78, the drive shaft of motor M3, intermediate idler pulley 72 and driven capstan 18b. Cable loop 46 returns from driven capstan 18b as cable C4 and engages intermediate idler pulley 74, the drive shaft of motor M4 and proximal idler pulley 78.

As shown in FIG. 6, proximal idler pulleys 78 and 80 are tensioned by cables C7 and C6 which are fixed to the center of proximal idler pulleys 78 and 80. Cables C7 and C6 form two sides of a single cable 45 which engages proximal idler pulley 82 which is rotatably mounted to support bracket 102 by shaft 82a. Shaft 82a is preferably movably mounted to support bracket 102 by a mechanism such as a lead screw. The lead screw may then be adjusted to appropriately tension cables C7 and C6. The tension is also applied via idler pulleys 78 and 80 to cables C1, C2, C3 and C4. A similar lead screw tensioning scheme can be used to tension cable C5 by longitudinal movement of idler pulley 83. It may be required for idler pulleys 82 and 83 to be mounted on separately adjustable shafts for these purpose instead of single shaft 82a illustrated in FIG. 3.

Driven capstans 18a and 18b may have different diameters in order to allow cables C1 through C4 to suitably engage their respective intermediate idler pulleys. Cables C1 and C2 engage the outer intermediate idler pulleys 70 and 76 while cables C3 and C4 engage the inner intermediate idler pulleys 72 and 74. Proximal idler pulleys 78 and 80 are sized such that pulley 80 is larger than pulley 78 to keep the cables straight.

Drive motors M1, M2, M3 and M4 control rotation of wrist member 22 about axis B-B, translation of instrument 12 longitudinally along axis C-C and rotation of work members 22a and 22b independent of each other about axis A-A by driving cables C1, C2, C3 and C4. Drive motors M1 and M2 drive cables C1/C2 in unison in opposition to cables C3/C4 driven by drive motors M3 and M4 in order to rotate wrist member 22 about axis B-B. Drive motor M1 drives cable C1 in opposition to cable C2 driven by drive motor M2 to rotate capstan 18a and attached work member 20a about axis A-A. In addition, drive motor M3 drives cable C3 in opposition to cable C4 driven by drive motor M4 to rotate capstan 18b and attached work member 20b about axis A-A. All four drive motors M1, M2, M3 and M4 drive cables C1, C2, C3 and C4 simultaneously to translate instrument 12 along longitudinal axis C-C.

Locating drive motors M1, M2, M3, M4 and M5 on sliding bracket 96 makes the distal portion 28b of instrument 12 have a small moving mass since the motors themselves remain stationary during actuation of the instrument. Although the motors are moved by positioning mechanism 14, the weight and inertia, of the motors do not affect force reflection. This is because, as stated above, in the preferred embodiment, only the instrument is used to reflect forces to the master. In addition,

employing cables instead of gears to control instrument 12 minimizes the amount of friction and backlash within instrument 12. The combination of small moving masses and low friction enables instrument 12 to provide force reflection to master device 150 with high sensitivity.

Certain possible changes to the configuration of pulleys, cables and motors described above will be apparent to those of skill in the art. Although cables C1/C2, C3/C4, C5 and C7/C6 have been depicted to be sides of the same cables, cables C1-C7 alternatively can each be individual cables which are fixed to driven capstans 18a and 18b, and proximal idler pulleys 78, 80 and 82. Moreover, although drive motors M1, M2, M3 and M4 have been depicted to drive cables C1, C2, C3 and C4 respectively, alternatively, some drive motors can be relocated from cables C1-C4 onto cables C7 and C6 for driving cables C7 and C6. The choice of the particular drive scheme employed in a particular embodiment will depend on the constraints of the forces required to be exerted by the instrument and the need to reduce the inertia and friction of the parts of the instrument that move during its actuation.

The surgical instrument of the present invention has been illustrated as using drive motors M1, M2, M3, M4 and M5. This drive motors may be standard servo motors having position encoders as shown in FIG. 3. However, other actuators may be used, such as hydraulic actuators and piezoelectric motors. To be used as an actuator in the present surgical instrument a drive mechanism should be able to provide variable and controllable force and position control.

Cables C1, C2, C3, C4, C7, C8 and C9 are driven by being wrapped about the drive shaft of their respective drive motors M1, M2, M3, M4, M5, M6 and M7. This cable drive method and an alternative cable drive method are illustrated in more detail in FIGS. 7a and 7b. For example, in FIG. 7a, cable C4 of cable loop 46 is wrapped around the drive shaft of motor M4. Cable C4 is preferably wrapped two times around the drive shaft to provide enough friction between the cable C4 and the drive shaft to prevent slippage. In order to further prevent slippage the cable may be fixed to the drive shaft at one point by soldering, welding or mechanical fixing means. However, in such an embodiment the range of motion of the cable is limited by the length of cable wrapped around the drive shaft or capstan thus several turns of cable are usually required.

FIG. 7b depicts another preferred method for driving cables. For example, motor M4 includes a drive wheel 43a and an idler wheel 43b for frictionally driving an elongate member 47 therebetween. Cable C4 consists of two halves, 46a and 46b which are fixed to opposite ends of member 47.

FIG. 8 depicts the distal end and wrist member 116 of another preferred instrument 117. Instrument 117 differs from instrument 12 in that instrument 117 includes eight intermediate idler pulleys instead of four. Instrument 117 includes intermediate idler pulleys 76, 74, 72 and 70 at wrist joint 16 but also includes intermediate idler pulleys 76a, 74a, 72a and 70a which are positioned adjacent to idler pulleys 76, 74, 72 and 70 on tongue 24a along shaft 118. Cables C1, C2, C3 and C4 do not make a complete wrap around each intermediate idler pulley but instead contacts a variable amount of the surface of each pulley varying in a range between 0.degree. and 180.degree. over the range of motion of the wrist about axis 16. This prevents the cables from crossing each other and rubbing together which prevents friction and noise.

Although the present invention has been described for performing laparoscopic surgery, it may also be used for other forms of endoscopic surgery as well as open surgery. The present manipulator could also be employed for any suitable

remote controlled application requiring a dexterous manipulator with high quality force feedback. Moreover, while this invention has been particularly shown and described with references to preferred embodiments thereof, it will be understood by those skilled in the art that various changes in form and details may be made therein without departing from the spirit and scope of the invention as defined by the appended claims.

What is claimed is:

1. An apparatus comprising:
  - an elongate support member having a proximal end and a distal end;
  - a wrist member coupled to the distal end of the elongate support by a wrist joint;
  - an end effector coupled to the wrist member by at least one joint, the end effector including first and second work members pivotally coupled to the wrist member, wherein the at least one work member can pivot relative to the wrist member; and
  - a drive system coupled to the proximal end of the elongate support member, the drive system comprising at least one actuator coupled to at least one drive element extending from the at least one actuator to the wrist joint; the apparatus further comprising pulleys rotatable about the wrist joint, the at least one actuator comprising four actuators, the at least one drive element comprising four cables extending from the four actuators through the wrist joint to the two work members.
2. The apparatus of claim 1, further comprising a sliding bracket housing the drive system.
3. The apparatus of claim 1, further comprising a support bracket, wherein:
  - the proximal end of the elongate support member is coupled to the support bracket by a rotary joint for rotation about a support axis and a linear joint for reciprocal motion along the support axis; and
  - the four actuators are coupled by the four cables to the wrist mechanism, the rotary joint and the linear joint such that selective actuation of the actuators operates to move the first work member of the end effector about two orthogonal axes with two degrees-of-freedom relative to the support member, extend and retract the support member along the support axis relative to the support bracket and

rotate the support member about the support axis relative to the support bracket and thereby move the first work member of the end effector relative to the support bracket with four degrees-of-freedom.

4. The apparatus of claim 3, comprising five actuators mounted on the support bracket coupled by five cables to the wrist mechanism, the rotary joint, the linear joint and the end effector wherein:

the end effector comprise a first work member and a second work member which can be moved in a scissor-like action relative to the first work member;

whereby selective actuation of the actuators operates to move the second work member relative to the first work member with one degree-of-freedom and move the first work member relative to the support bracket with four degrees-of-freedom.

5. The apparatus of claim 3, comprising a mounting bracket connected to the support bracket wherein the mounting bracket is adapted to releasably connect the elongate support member to a positioning mechanism.

6. The apparatus of claim 3, wherein a first actuator drives a first cable in opposition to a second cable driven by a second actuator to move the first work member with a first degree-of-freedom relative to the support member.

7. The apparatus of claim 6, wherein a third actuator drives a third cable in opposition to a fourth cable driven by a fourth actuator to move the second work member relative to the first work member with one degree-of-freedom.

8. The apparatus of claim 7, wherein the first and second actuators drive the respective first and second cables in unison in opposition to the third and fourth cables driven in unison by the respective third and fourth actuators in order to move the first work member relative to the support member with a second degree-of-freedom.

9. The apparatus of claim 6, wherein the first, second, third and fourth actuators drive respective first, second, third and fourth cables in unison in order to move the elongate support member along the support axis.

10. The apparatus of claim 1, the drive system further comprising an actuator configured to rotate the elongate support member about a longitudinal axis extending from the proximal end to the distal end.

\* \* \* \* \*



专利名称(译)	用于执行微创手术的铰接式手术器械，具有增强的灵活性和灵敏度		
公开(公告)号	<a href="#">US8709000</a>	公开(公告)日	2014-04-29
申请号	US13/721508	申请日	2012-12-20
[标]申请(专利权)人(译)	直观外科手术操作公司		
当前申请(专利权)人(译)	Intuitive Surgical公司运营，INC.		
[标]发明人	MADHANI AKHIL J SALISBURY J KENNETH		
发明人	MADHANI, AKHIL J. SALISBURY, J. KENNETH		
IPC分类号	A61B19/00 B25J9/10 B25J3/04 A61B1/00 B25J17/02 A61B17/00 B25J3/00 A61B17/28		
CPC分类号	A61B2019/223 A61B2017/2939 A61B2019/2234 A61B2019/2223 A61B2017/2929 B25J3/04 A61B2019/2296 A61B17/00234 A61B2019/2246 A61B2019/2242 A61B19/22 B25J9/104 A61B2017/2927 A61B19/2203 A61B2019/2292 A61B34/30 A61B17/29 A61B34/35 A61B34/37 A61B34/70 A61B34/71 A61B34/76 A61B34/77 A61B2034/305 A61B2034/306 A61B2034/715 Y10T74/20329 Y10T74/20335		
优先权	60/017981 1996-05-20 US		
其他公开文献	US20130110131A1		
外部链接	<a href="#">Espacenet</a> <a href="#">USPTO</a>		

摘要(译)

一种用于增强微创外科手术的性能的铰接式外科手术器械。该仪器具有高灵活性，低摩擦，低惯性和良好的力反射。独特的电缆和滑轮驱动系统可以减少摩擦并增强力反射。与标准腹腔镜器械相比，独特的腕部机构可提高手术灵活性。该系统经过优化，可减少所需的执行器数量，从而生产出最小尺寸的全功能铰接式手术器械。

