

FIG. 1

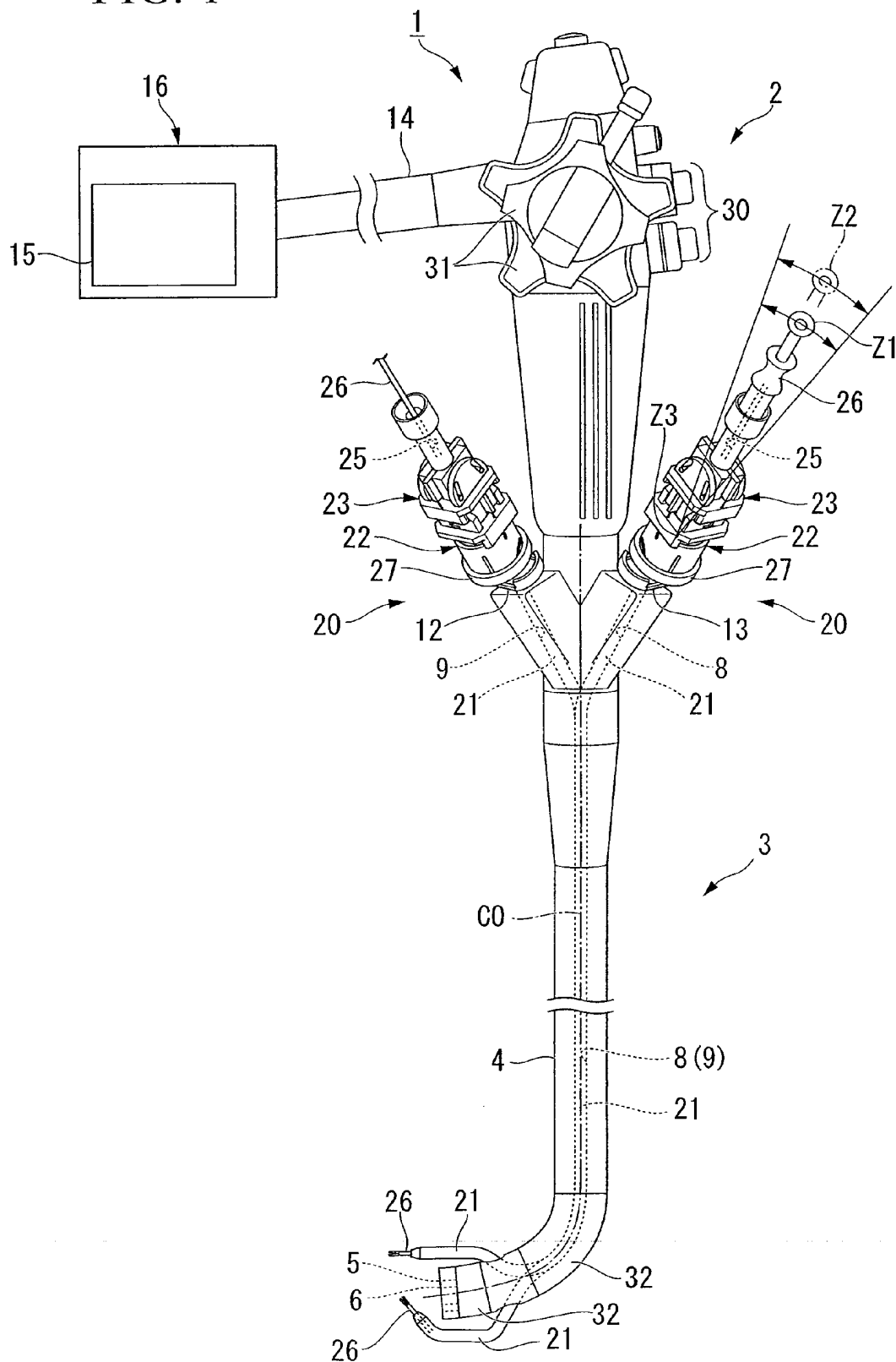

FIG. 11

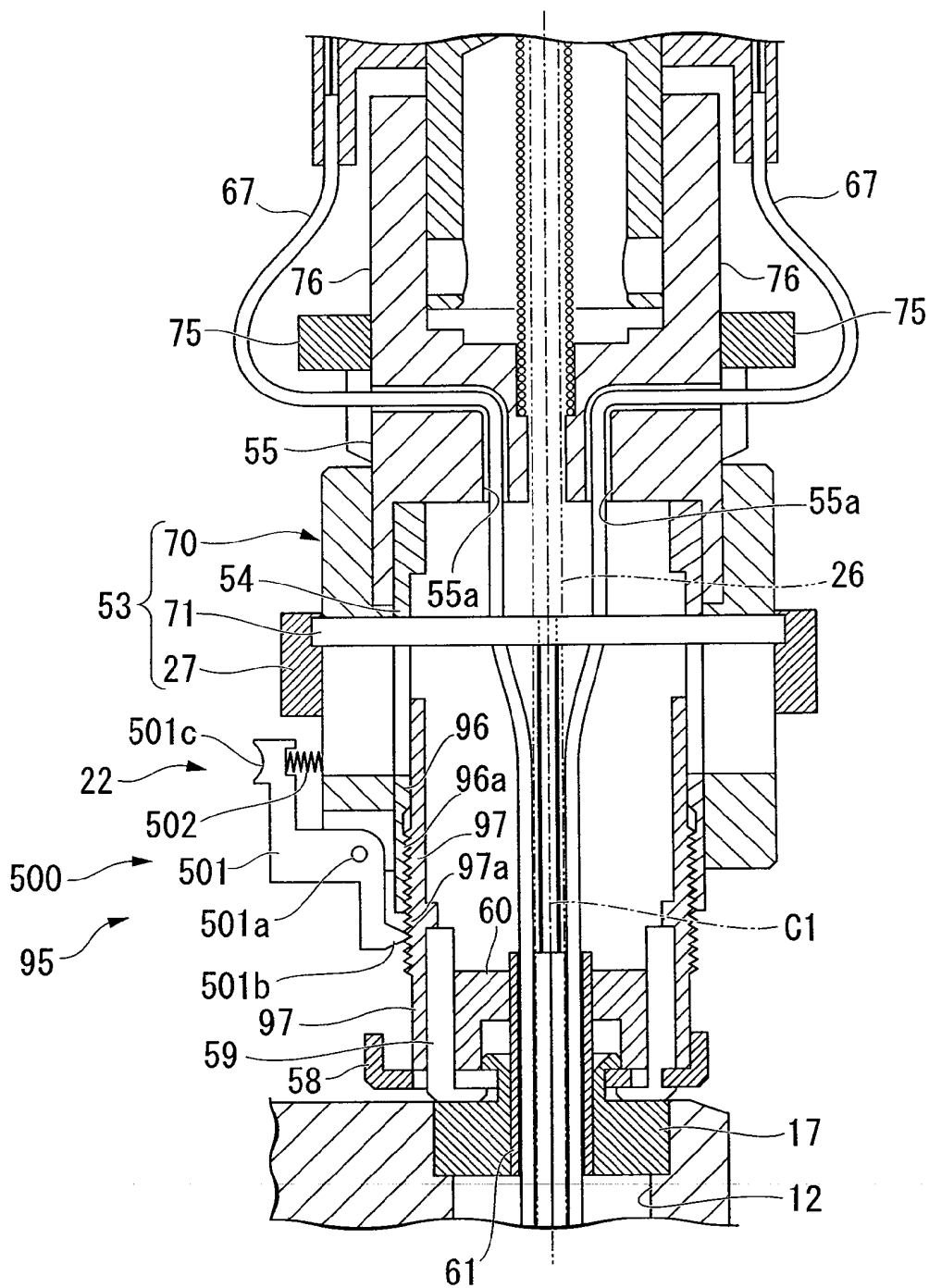

FIG. 12

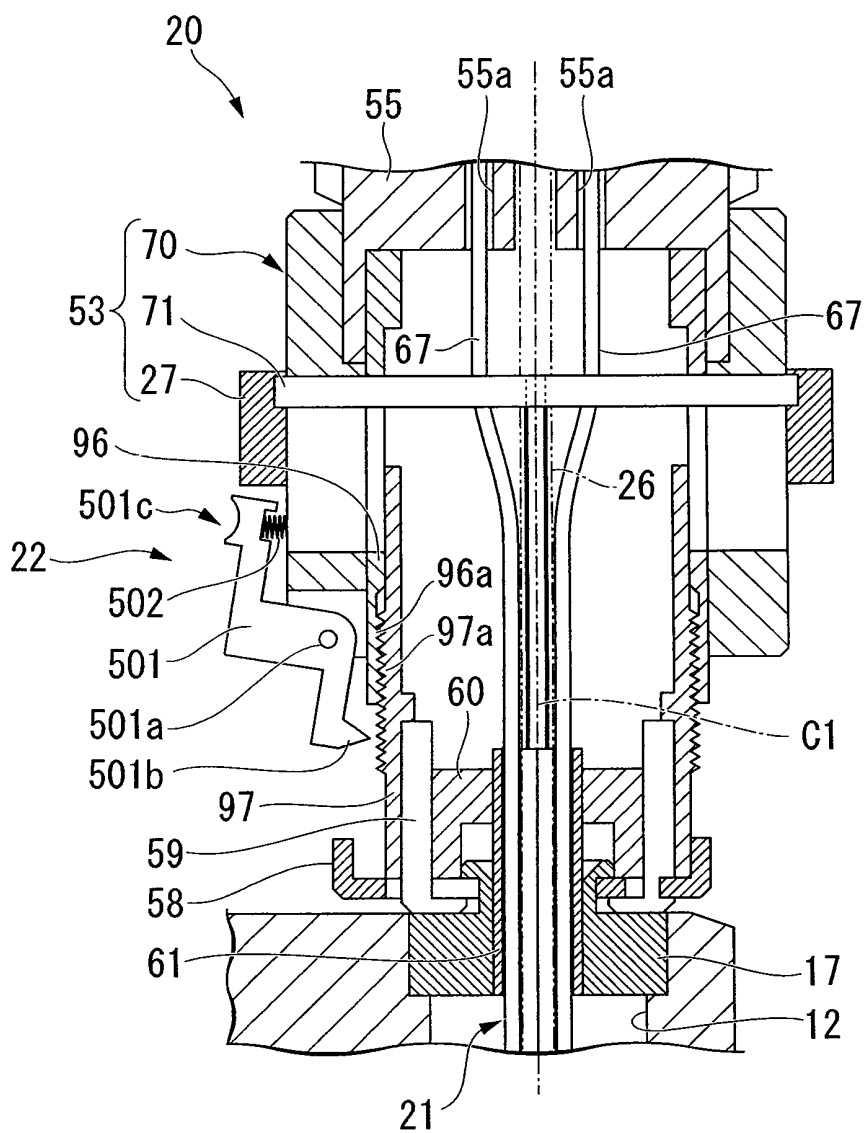

FIG. 15

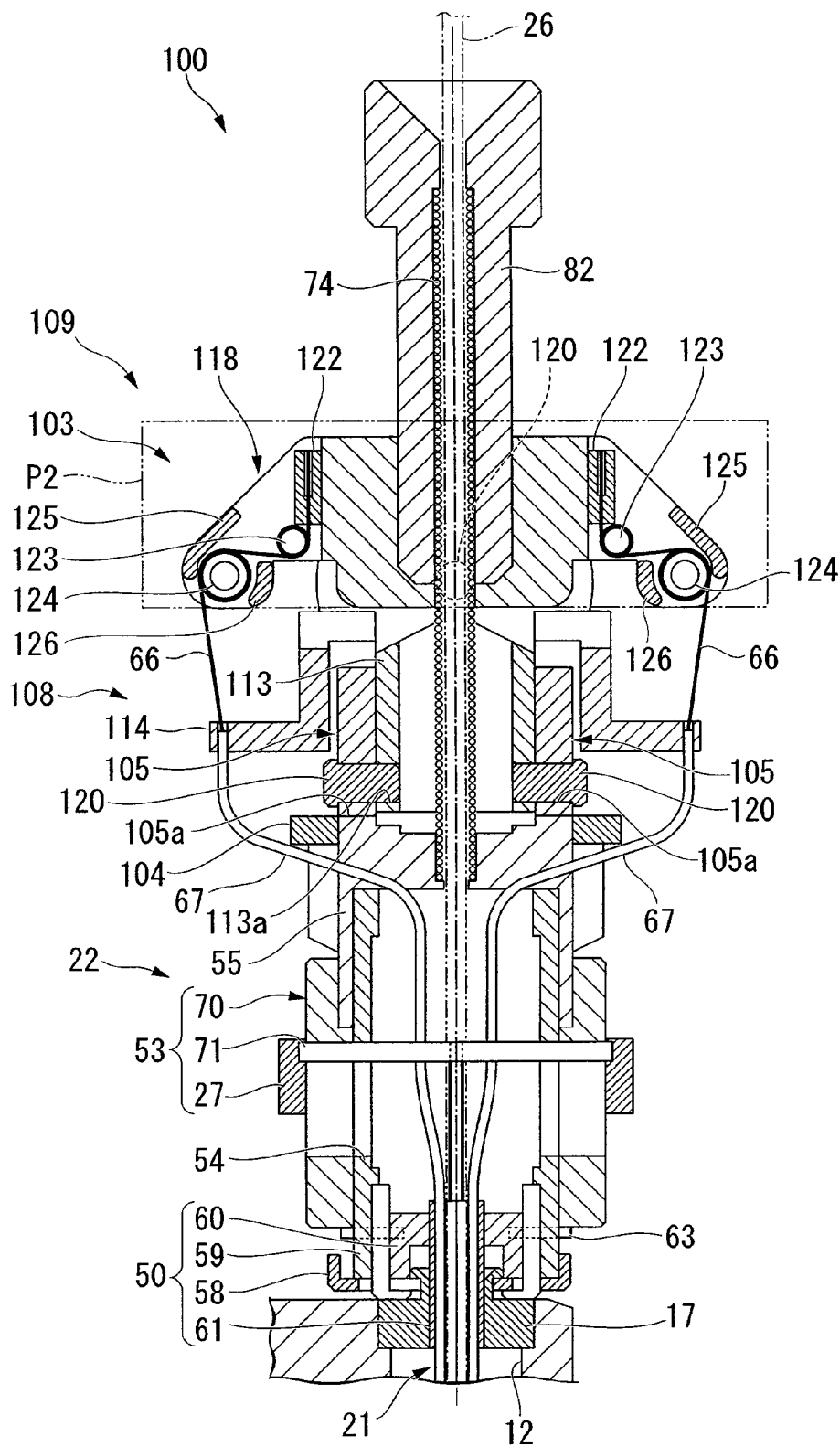

FIG. 16

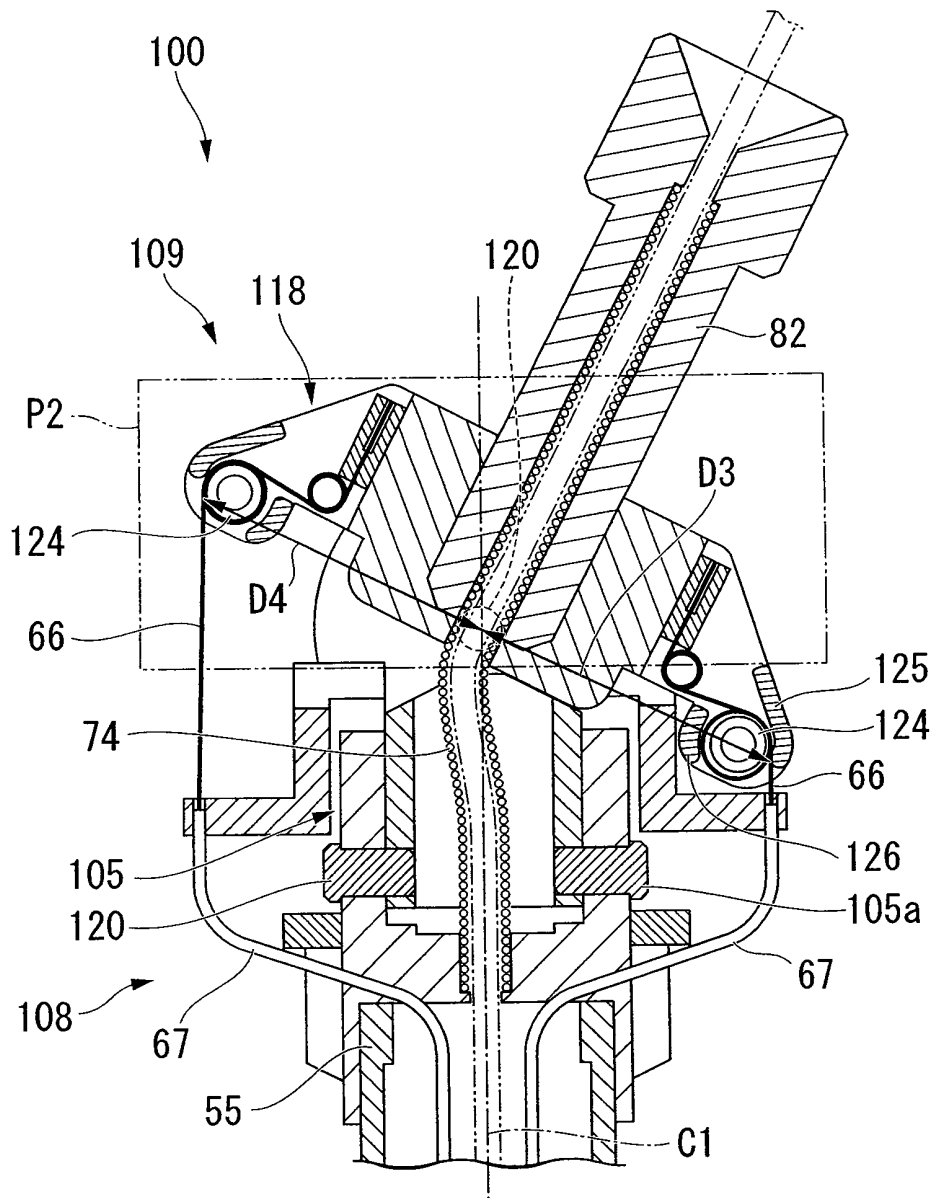

FIG. 17

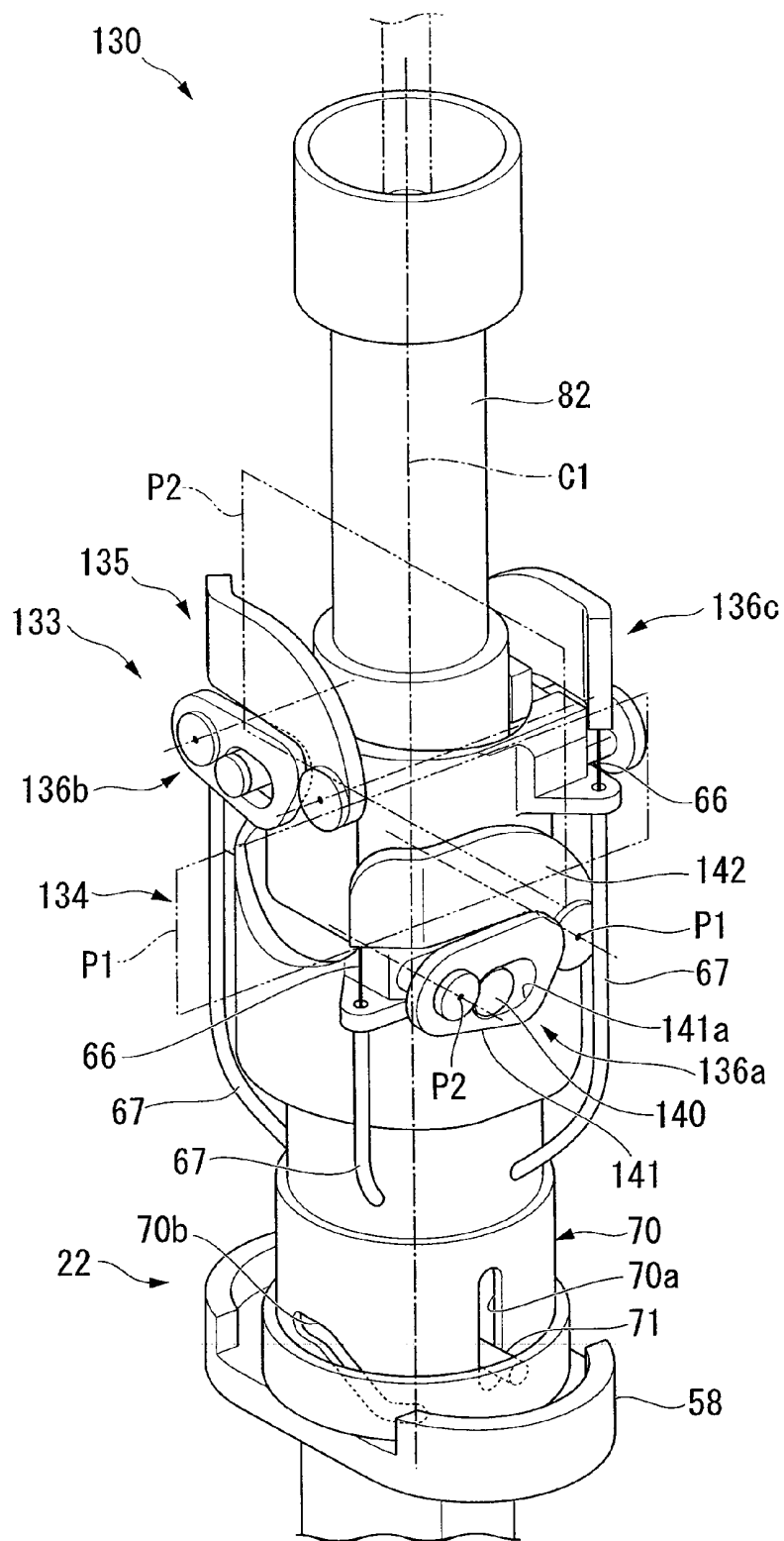

FIG. 18

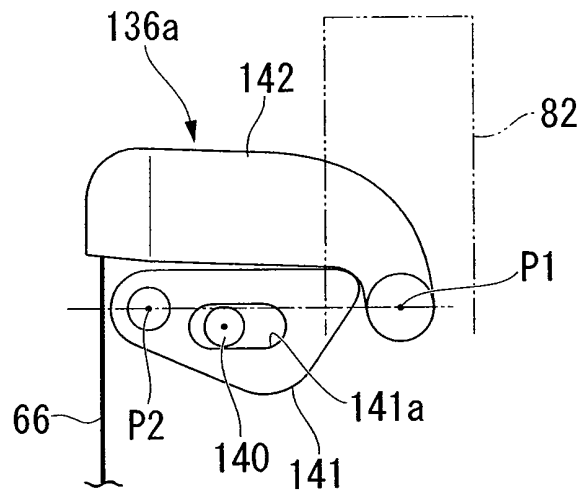

FIG. 19

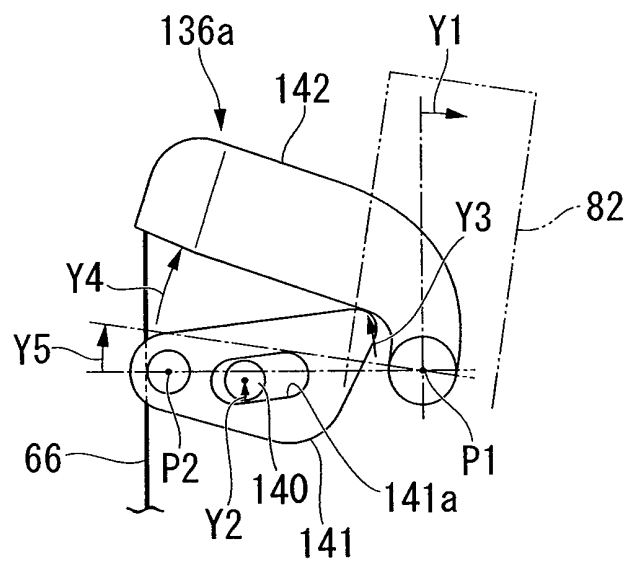

FIG. 22

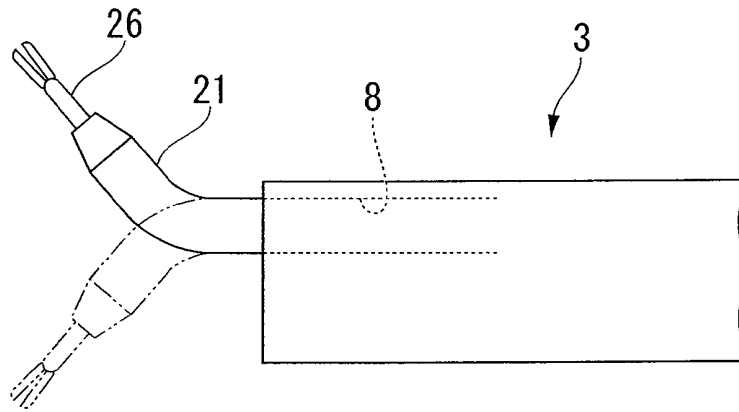

FIG. 23

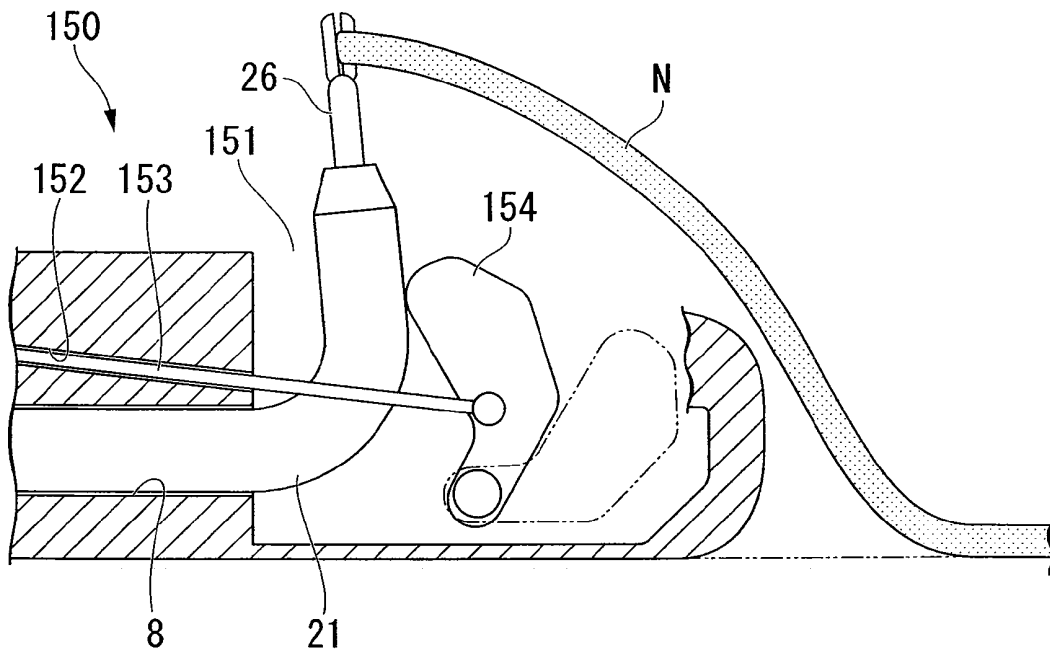

FIG. 24

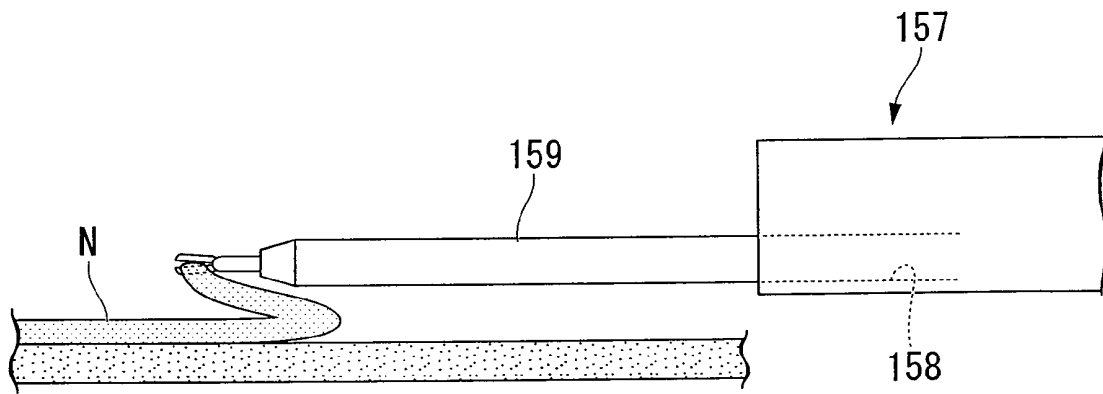

FIG. 25

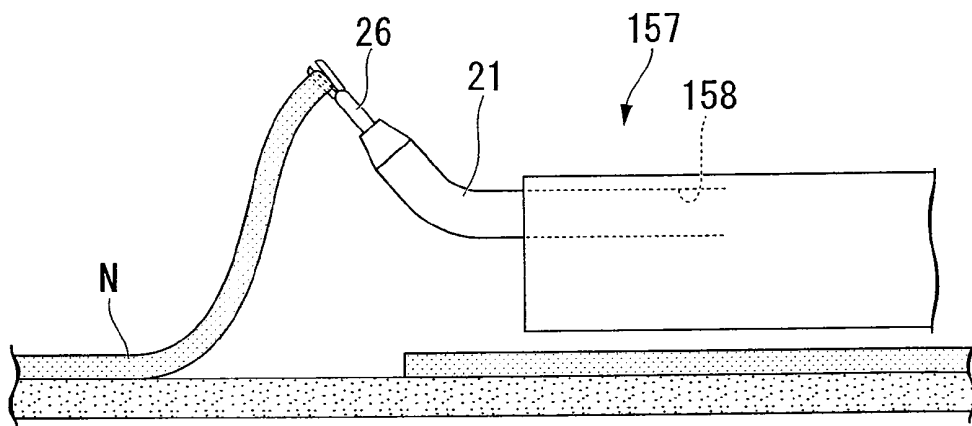

FIG. 26

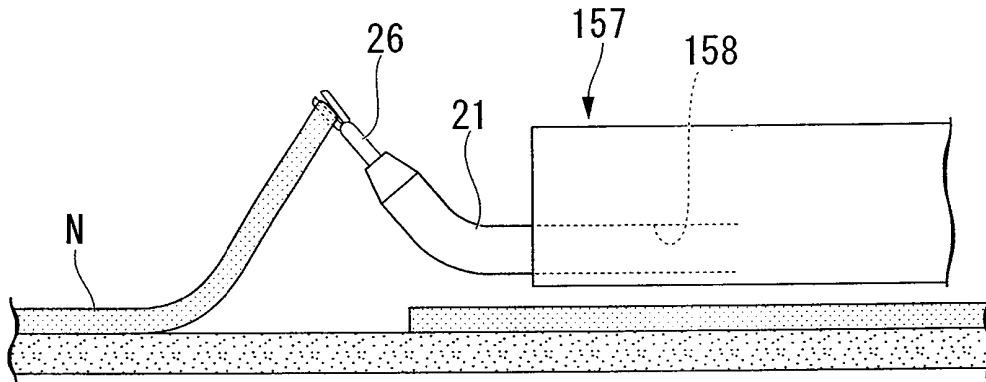

FIG. 27

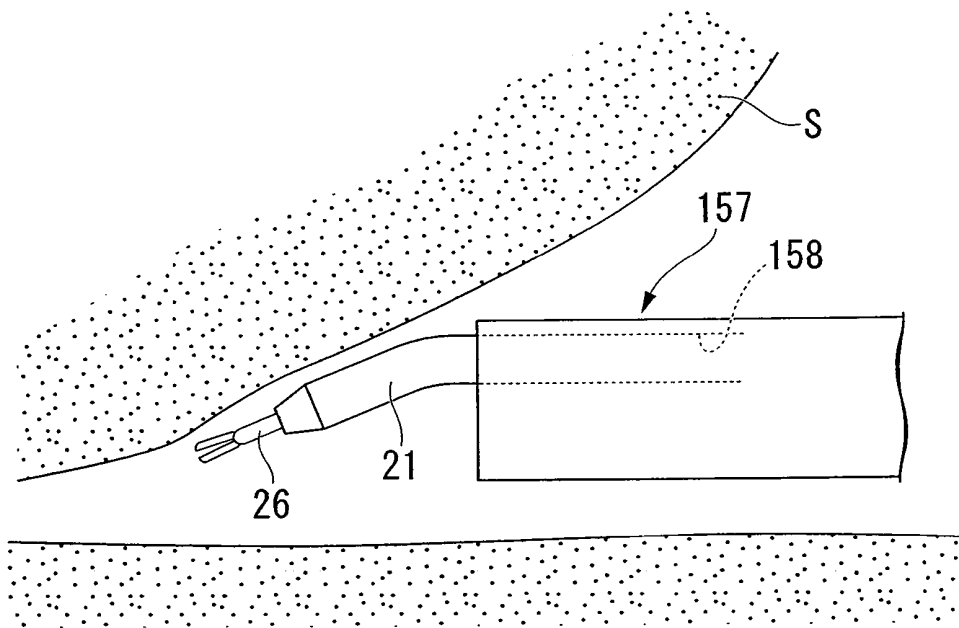

FIG. 28

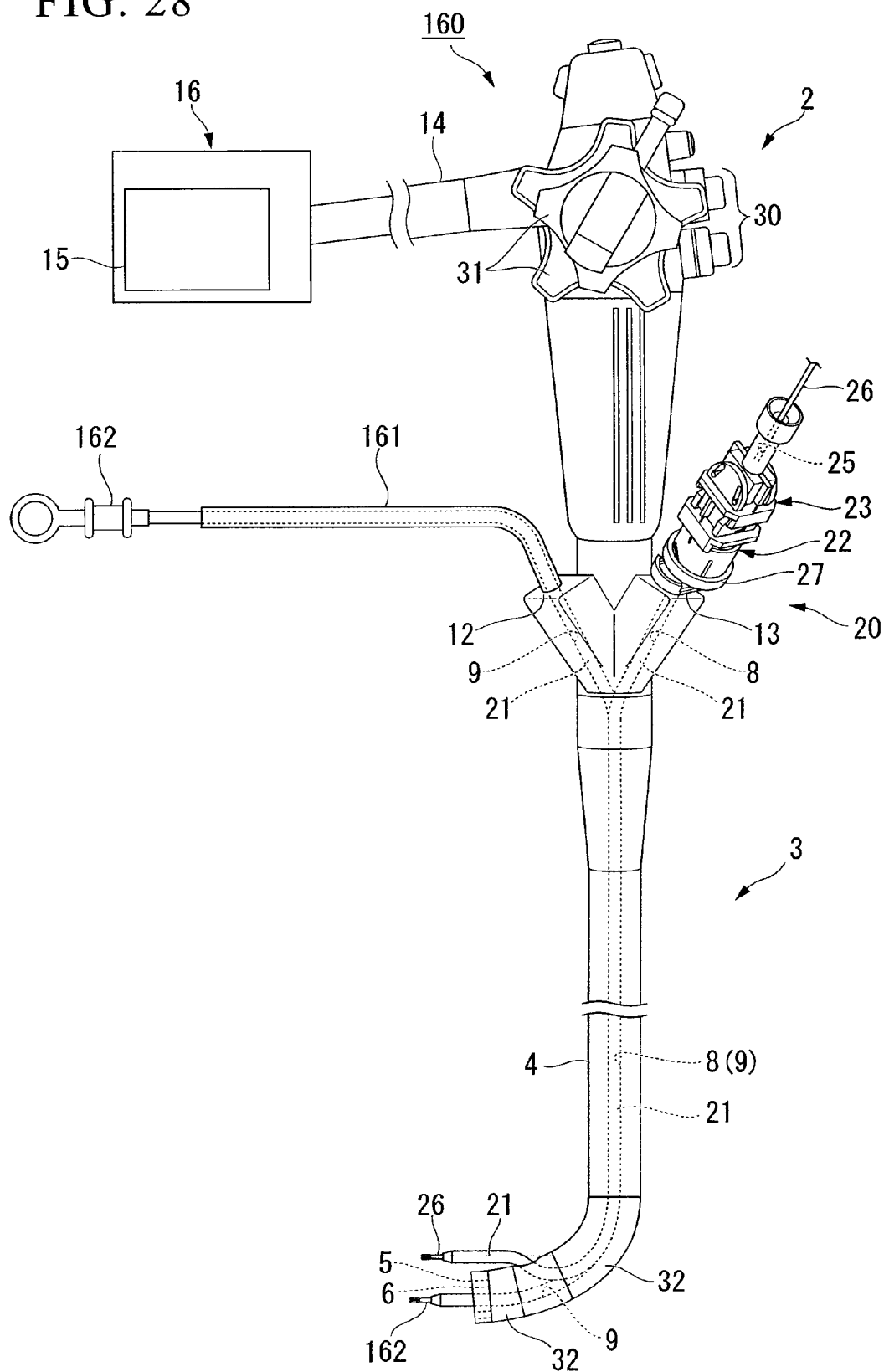

FIG. 29

	LEFT TREATMENT TOOL	RIGHT TREATMENT TOOL
PATTERN A	ARM MECHANISM WITH SECOND CURVE	ARM MECHANISM WITH SECOND CURVE
PATTERN B	ARM MECHANISM WITHOUT SECOND CURVE	ARM MECHANISM WITHOUT SECOND CURVE
PATTERN C	COMMON TREATMENT TOOL OR CLAMP RASING STAND	ARM MECHANISM WITH SECOND CURVE
PATTERN D	COMMON TREATMENT TOOL OR CLAMP RASING STAND	ARM MECHANISM WITHOUT SECOND CURVE

FIG. 30

	LEFT AND RIGHT TREATMENT TOOLS	EXISTENCE AND THE LIKE OF ASSISTANT
PATTERN A	CASE WHERE LEFT AND RIGHT ARMS ARE ARM MECHANISMS	SURGEON PERFORMS OPERATIONS OF RECIPROCATING, OPENING/CLOSING, AND ROTATING TREATMENT TOOL.
PATTERN B	CASE WHERE ONE IS ARM MECHANISM, THE OTHER IS GENERAL CLAMP, AND TISSUE IS TURNED OVER JUST BY RECIPROCATING CLAMP	CASE WITHOUT ASSISTANT. SURGEON PERFORMS OPERATIONS OF RECIPROCATING, OPENING/CLOSING, AND ROTATING ARM MECHANISM AND CLAMP.
PATTERN C		CASE WITH ASSISTANT. ASSISTANT PERFORMS OPERATIONS OF OPENING/CLOSING AND ROTATING CLAMP AND SURGEON PERFORMS OPERATION OF RECIPROCATING CLAMP.
PATTERN D		CASE WITH ASSISTANT. ASSISTANT PERFORMS OPERATIONS OF RECIPROCATING, OPENING/CLOSING, AND ROTATING CLAMP.
PATTERN E		CASE WITHOUT ASSISTANT.
PATTERN F	CASE WHERE ONE IS ARM MECHANISM AND ARM MECHANISM IS BENT BY CLAMP RASING STAND SO AS TO ELEVATE OR PULL TISSUE	CASE WITH ASSISTANT. ASSISTANT PERFORMS OPERATIONS OF OPENING/CLOSING AND ROTATING TREATMENT TOOL.
PATTERN G		CASE WITH ASSISTANT. ASSISTANT PERFORMS OPERATIONS OF RECIPROCATING, OPENING/CLOSING, AND ROTATING TREATMENT TOOL.

MANIPULATION MECHANISM AND MEDICAL DEVICE INSTRUMENT

BACKGROUND OF THE INVENTION

1. Field of the Invention

The present invention relates to a manipulation mechanism and a mechanical instrument which is used while being inserted into a body cavity in combination with a soft endoscope.

Priority is claimed on U.S. Provisional Application No. 61/093,492, filed Sep. 2, 2008, the content of which is incorporated herein by reference.

2. Background Art

As a method of performing a medical action such as an observation or a treatment on the internal organs of a human body, there is known a laparoscopic surgery which performs a surgical technique by forming a plurality of openings in an abdominal wall instead of making a large incision, and inserting the medical instruments such as an abdominoscope or a clamp into the respective openings. In such a surgery, since only small openings are formed in the abdominal wall, it is advantageous in that the stress on the patient is reduced.

In addition, as a method of reducing the stress to the patient, a method has been proposed for performing a surgical technique by inserting a soft endoscope through a natural passageway such as patient's mouth, nose, or anus. An example of an endoscope device (medical instrument) used in such a surgical technique is disclosed in US Patent Application Laid-open No. 2005/0065397.

In the disclosed endoscope device, arm portions of which front ends can be bent are respectively inserted through a plurality of lumens disposed in a soft inserting portion inserted through a patient's mouth. When treatment tools are respectively inserted through the arm portions, it is possible to approach the treatment tools to a treatment portion in different directions, and to continuously perform a plurality of surgical techniques in a state in which one endoscope is inserted into a body cavity.

Also, in the arm portion (manipulation mechanism) disclosed in the above-described specification, four pulling wires are disposed along the arm portion so as to be located at the same interval in the circumferential direction. In the pulling wires, the base ends are attached to a steering opening (oscillating body) in the base end of the arm portion, and the front ends are attached to the front end of the arm portion. In addition, it is possible to change a direction of the treatment portion protruding from the front end of the arm portion by curving the front end of the arm portion in such a manner that the base end of the treatment tool communicating with the opening and the arm portion is inclined so as to rotate the opening relative to the arm portion.

However, the method of attaching the opening to the base end of the arm portion is not clearly shown. Additionally, the position of the opening deviates from the base end of the arm portion when the opening is rotated, which may deteriorate the operability of the treatment tool.

SUMMARY OF THE INVENTION

The present invention is contrived in consideration of the above-described problems, and an object of the invention is to provide a manipulation mechanism that an oscillating body moves in a stable locus, and a medical instrument having the manipulation mechanism.

In the present invention, there is provided a manipulation mechanism including: an oscillating body which is disposed

on a first imaginary plane, where first and second imaginary planes are parallel to each other with respect to a manipulation reference plane; and a holding body which is disposed on the second imaginary plane so as to regulate an oscillating locus of the oscillating body, wherein the oscillating body is provided with first and second convex portions which are spaced from each other and protrude toward the holding body; the holding body is provided with first and second groove portions which respectively guide the first and second convex portions; and the first and second groove portions are formed to be closer to each other in a direction away from the manipulation reference plane on one side of the manipulation reference plane from a point on the manipulation reference plane as a start point.

BRIEF DESCRIPTION OF THE DRAWINGS

FIG. 1 is an overall view showing an endoscope device according to a first embodiment of the present invention.

FIG. 2 is an enlarged cut-away view showing a part of a front end of an insertion portion of the endoscope device.

FIG. 3 is a perspective view showing a main part of an arm mechanism of the endoscope device.

FIG. 4 is a front view showing the main part of the arm mechanism.

FIG. 5 is a sectional view showing the main part of the arm mechanism.

FIG. 6 is a sectional view showing the periphery of a holding mechanism of the arm mechanism.

FIG. 7 is an explanatory diagram showing an observed image through a monitor of the endoscope device.

FIG. 8 is a sectional view showing an operation of the main part of the arm mechanism.

FIG. 9 is a sectional view showing an operation in the periphery of the holding mechanism of the arm mechanism.

FIG. 10 is a sectional view showing an operation in the periphery of the holding mechanism of the arm mechanism.

FIG. 11 is a sectional view showing a main part of the arm mechanism according to a modified example of the first embodiment of the present invention.

FIG. 12 is a sectional view showing an operation of the arm mechanism according to the modified example.

FIG. 13 is an overall view showing the endoscope device according to the modified example.

FIG. 14 is a perspective view showing a main part of the arm mechanism of the endoscope device according to a second embodiment of the present invention.

FIG. 15 is a sectional view showing the main part of the arm mechanism.

FIG. 16 is a sectional view showing an operation of the main part of the arm mechanism.

FIG. 17 is a perspective view showing a main part of the arm mechanism of the endoscope device according to a third embodiment of the present invention.

FIG. 18 is an explanatory diagram showing a link mechanism of the arm mechanism.

FIG. 19 is an explanatory diagram showing an operation of the link mechanism of the arm mechanism.

FIG. 20 is a perspective view showing the endoscope device according to a fourth embodiment of the present invention.

FIG. 21 is a perspective view showing the endoscope device according to a fifth embodiment of the present invention.

FIG. 22 is an explanatory diagram showing a main part of the endoscope device according to the present invention.

FIG. 23 is an explanatory diagram showing a main part of the endoscope device according to the present invention.

FIG. 24 is an explanatory diagram showing a main part of the endoscope device according to the present invention.

FIG. 25 is an explanatory diagram showing a main part of the endoscope device according to the present invention.

FIG. 26 is an explanatory diagram showing a main part of the endoscope device according to the present invention.

FIG. 27 is an explanatory diagram showing a main part of the endoscope device according to the present invention.

FIG. 28 is an explanatory diagram showing the endoscope device according to the present invention.

FIG. 29 is a table showing a pattern of a treatment tool of the endoscope device according to the present invention.

FIG. 30 is a table showing patterns obtained by the relationship between a treatment tool of the endoscope device according to the present invention and an existence of an assistant.

DETAILED DESCRIPTION OF THE INVENTION

Hereinafter, embodiments of the present invention will be described. In addition, the basic structure of an endoscope device is disclosed in U.S. patent Ser. No. 11/652,880 which is related to the present invention, and the disclosed contents are incorporated in the following description by reference.

First Embodiment

An endoscope device 1 according to this embodiment is used to perform a treatment inside a comparatively narrow space such as a digestive canal, and one surgeon is capable of manipulating the endoscope device and performing a treatment by using the endoscope device. In addition, for convenience of description, parts of several diagrams are omitted.

As shown in FIG. 1, the endoscope device 1 has a configuration in which a tubular endoscope inserting portion 3 integrally extends from one end of an endoscope manipulating portion 2 and two arm mechanisms (medical instruments) 20 are attached to the one end.

The endoscope inserting portion 3 is elongate and flexible, and the configuration thereof is the same as that disclosed in U.S. patent Ser. No. 11/652,880. That is, the endoscope inserting portion 3 includes a flexible sheath 4 which covers the outer peripheral surface of the endoscope inserting portion 3, an illumination mechanism 5 which applies illumination light in the forward direction, and an observation mechanism 6 which has an imaging element such as a CCD (not shown in the figure) for observing a forward area. In addition, the inside of the endoscope inserting portion 3 is provided with a first lumen (operation channel) 8 and a second lumen (operation channel) 9 which extend from the front end of the endoscope inserting portion 3 to the endoscope manipulating portion 2.

The endoscope manipulating portion 2 includes clamp openings 12 and 13 which respectively communicate with the first and second lumens 8 and 9, and a control mechanism 16 which is connected to the endoscope manipulating portion 2 through a universal cable 14 and which has a monitor 15. The control mechanism 16 has a light source (not shown in the figure) which supplies illumination light to the illumination mechanism 5. In addition, the image observed by the observation mechanism 6 is transmitted to the control mechanism 16 through the universal cable 14, and is displayed on the monitor 15 through an appropriate image process.

In addition, the endoscope manipulating portion 2 further includes a switch 30 and an angle knob 31. The switch 30 is

manipulated, for example, upon performing an air supply operation, a water supply operation, and a suction operation through the first lumen 8. The angle knob 31 is used when a third curve 32, described later, of the endoscope inserting portion 3 is bent in four directions with respect to the axis.

As shown in FIG. 2, in the inside of the endoscope inserting portion 3, in the same manner as the known configuration, a plurality of substantially cylindrical curve pieces 36 is disposed to be connected to each other in a predetermined range along the axis C0 of the endoscope inserting portion 3, and the third curve 32 of the front end of the endoscope inserting portion 3 can be bent with respect to the axis C0.

In the inside of the endoscope inserting portion 3, a first support piece 35 which has the illumination mechanism 5 and the observation mechanism 6 attached to a front end surface thereof and is formed in a cylindrical shape provided with a top, the plurality of curve pieces 36, a second substantially cylindrical support piece 37 which has a pair of openings 37a at opposing side surfaces, and the plurality of curve pieces 36 are disposed in a sequential order from the front end of the endoscope inserting portion 3. In addition, a portion between the first support piece 35 and the curve piece 36, a portion between the second support piece 37 and the curve piece 36, and a portion between the curve pieces 36 are perpendicular to the axis C0 of the endoscope inserting portion 3, and are rotatably connected a plurality of hinges 39 which is differently disposed in a direction seen from the axis C0.

The front ends of four endoscope manipulating wires (not shown in the figure) disposed at the same interval in the circumferential direction are attached to an inner surface of a base end of the first support piece 35, and the endoscope manipulating wires disposed at opposing positions to make a pair. The base ends of two pairs of endoscope manipulating wires are inserted through the inside of the endoscope inserting portion 3 and the endoscope manipulating portion 2, and are respectively fixed to the angle knob 31. Then, when the angle knob 31 is rotated, it is possible to rotate the third curve 32 in four directions with respect to the axis C0.

In the front end of the endoscope inserting portion 3, the first lumen 8 and the second lumen 9 displace from the axis C0 of the endoscope inserting portion 3 so as to respectively communicate with passageways 37a of the second support piece 37.

In this embodiment, in the front end of the endoscope inserting portion 3, the ranges of the lengths A1 and A2 of the first and second support pieces 35 and 37 taken along the axis C0 are the rigid ranges in which the endoscope inserting portion 3 cannot be bent, and the other ranges are the soft ranges in which the endoscope inserting portion 3 can be bent.

As shown in FIG. 1, each of the arm mechanisms 20 includes an arm portion (inserting portion) 21 which is formed in an elongate tubular shape so as to be bent, a body portion 22 which is formed in a shaft shape so as to be connected to the arm portion 21, and an arm manipulating portion (manipulating mechanism) 23 which is attached to the body portion 22 and is used to manipulate the front end of the arm portion 21 to be bent. A treatment tool 26 such as a gripping clamp can be reciprocally inserted through a channel 25 which is formed to communicate with the arm portion 21, the body portion 22, and the arm manipulating portion 23. In this embodiment, two arm mechanisms 20, through which the treatment tool 26 is inserted, are used. The first lumen 8, the second lumen 9, and the arm portion 21 are separably and reciprocally inserted through each arm mechanism 20, and the bodies 22 are respectively attached to the clamp pieces 12 and 13. In addition, in the inside of the

first lumen 8 and the second lumen 9, the arm portion 21 is adapted to be rotatable about the axis thereof.

In order to prevent the movements of the arm manipulating portions 23 from interfering with each other, the arm mechanisms 20 through which the lumens 8 and 9 are inserted are respectively attached to the clamp openings 12 and 13 so that the base ends of the arm mechanisms 20 are distant from each other while forming a predetermined angle with respect to the axis C0 of the endoscope inserting portion 3.

Note that, in this embodiment, the gripping clamp is used as the treatment tool 26, but the present invention is not limited thereto. For example, a high-frequency knife, a snare, or the like may be used as the treatment tool 26.

In the inside of the arm portion 21, in the same manner as the above-described endoscope inserting portion 3, curve pieces (not shown in figure) are disposed to be connected to each other in a predetermined range along the axis of the arm portion 21 in the front end of the arm portion 21.

the front ends of four arm portion manipulating wires (not shown in figure) (first and second manipulation members) disposed at the same interval in the circumferential direction are attached to the inner surface of the base end side of the curve piece disposed at the forefront end of the arm portion 21, and the arm portion manipulating wires disposed at the opposing positions to make a pair. Two pairs of arm portion manipulating wires are respectively inserted through arm portion manipulating sheaths (not shown in figure) disposed and fixed to the inside of the arm portion 21, and the base ends of the arm portion manipulating wires respectively extend to the arm manipulation portions 23 of the arm mechanisms 20. In addition, when the arm portion manipulating wires are pulled, it is possible to bend a first curve (curve portions) 43.

In addition, as shown in FIG. 2, in the arm portion 21, front ends of a pair of second curve manipulating wires (not shown in figure) are attached to an inner surface of a curve piece disposed at a second curve 42 corresponding to a middle portion of the curve pieces connected to each other through a predetermined range. Each second curve manipulating wire is inserted through a second curve manipulating sheath (not shown) disposed and fixed to the inside of the arm portion 21, and the base end of the second curve manipulating wire extends to the body portion 22 of the arm mechanism 20.

In addition, the arm portions 21 are respectively inserted through passageways 4a formed in the sheath 4 and the lumens 8 and 9, and protrude forward from the front end surface 3a of the endoscope inserting portion 3.

Next, the configuration of the body portion 22 and the arm manipulating portion 23 of the arm mechanism 20 will be described with reference to FIGS. 3 to 5. In addition, for convenience of description, FIGS. 3 to 5 show a state where a second curve manipulating ring 27 to be described later is pushed down. Further, since the clamps 12 and 13 have the same configuration, the clamp 12 will be described.

The body portion 22 includes an engagement mechanism 50 which engages with an opening metal 17 of the clamp opening 12, a second curve manipulating mechanism 53 which pulls a base end of a second curve manipulating wire 51, a first substantially cylindrical body member 54 which is attached with the engagement mechanism 50 and the second curve manipulating mechanism 53, and a second substantially cylindrical body member 55 which is coaxially fixed to the base end of the first body member 54 and supports the arm manipulating portion 23 in an oscillating manner.

The engagement mechanism 50 includes a slide member 58 which is formed in a plate shape and engages with the opening metal 17, a guide ring 59 which supports the slide member 58, a substantially cylindrical support member 60

which supports the slide member 58 between the guide ring 59 and the support member 60, and a tubular connection pipe 61 which is disposed on the axis C1 of the body portion 22 and is fixed to the support member 60 so as to be connected to the arm portion 21.

A substantially circular hole portion 58a is formed in the center portion of the slide member 58. When the slide member 58 moves in a direction perpendicular to the axis C1 of the body portion 22, the hole portion 58a engages with a circular flange portion 17a formed in the opening metal 17 so that the engagement mechanism 50 of the body portion 22 is fixed to the clamp opening 12. The guide ring 59 is made of, for example, metal such as stainless steel, and includes a substantially cylindrical body portion and an annular claw portion 59a which protrudes from one end of the body portion to the inside in the radial direction and interposes the slide member 58 between the flange portion 17a and the claw portion 59a.

In addition, the first body member 54, the guide ring 59, and the support member 60 are fixed from the side surface of the first body member 54 by a pin member 63. Further, the second curve manipulating sheath 52 and the arm portion manipulating sheath 67 are fixed to the connection pipe 61.

Likewise, since the guide ring 59 is made of metal such as stainless steel, even when large torque acts on the arm mechanism 20 about the hole portion 58a of the slide member 58 upon oscillating the arm manipulating portion 23, it is possible to prevent the claw portion 59a of the guide ring 59 from being damaged, where particularly large torque acts on the claw portion.

The second curve manipulating mechanism 53 includes a cylindrical guide member 70 which is fixed to the outer radial portion of the first body member 54, a second annular curve manipulating ring 27 which is disposed in the outer radial portion of the guide member 70, and a bar member 71 which is locked to the second curve manipulating ring 27 so as to be movable along the axis C1 and is attached with the base end of the second curve manipulating wire 51.

The side surfaces of the guide member 70 and the first body member 54 are respectively provided with a pair of slits 70a and 54a formed along the axis C1 and communicating with each other so as to face each other.

In the outer peripheral surface of the guide member 70, groove portions 70b are formed at two opposing positions. In more detail, in the groove portion 70b, a first groove portion 70c and a second groove portion 70d formed in a surface perpendicular to the axis C1 are connected to a third spiral groove portion 70e in a sequential order of the first groove portion 70c, the third groove portion 70e, and the second groove portion 70d so as to be formed in a substantially spiral shape as a whole, where the third spiral groove portion 70e is formed in a spiral shape so as to be close to the base end thereof when rotating in a direction depicted by E1 about the axis C1.

Particularly, as shown in FIG. 3, the inner peripheral surface of the second curve manipulating ring 27 is provided with a pair of convex portions 27a protruding inward in the radial direction so as to face each other, and the pair of convex portions 27a engages with the groove portions 70b of the guide member 70. In addition, the inner peripheral surface of the second curve manipulating ring 27 is provided with a pair of groove portions 27b formed at opposing positions so as to extend in the circumferential direction. The bar member 71 is inserted through the slit 70a of the guide member 70 and the slit 54a of the first body member 54 so as to be locked to the groove portion 27b of the second curve manipulating ring 27 at both ends of the bar member 71.

Since the second curve manipulating mechanism **53** has the above-described configuration, when the second curve manipulating ring **27** disposed at a position shown in FIGS. **3** to **5** is rotated in a direction depicted by **E1** about the axis **C1**, the second curve manipulating ring **27** moves to the base end of the body portion **22** while rotating in a direction depicted by **E1** as the convex portion **27a** moves to the base end of the body portion **22** along the groove portion **70b**. Since the bar member **71** is locked to the groove portion **27b** of the second curve manipulating ring **27** and is inserted through the slit **70a** and the slit **54a**, both ends of the bar member **71** move in the inside of the groove portion **27b** in the circumferential direction of the second curve manipulating ring **27**, and the bar member **71** moves to the base end along the slit **70a** without rotating in a direction depicted by **E1**. Likewise, the bar member **71** is capable of pulling the base end of the second curve manipulating wire **51** without twisting the second curve manipulating wire **51**. In addition, when the convex portion **27a** arrives at the second groove portion **70d** of the groove portion **70b**, the second curve manipulating ring **27** is fixed to the guide member **70** by means of the friction between the convex portion **27a** and the second groove portion **70d**. Even when the second curve manipulating ring **27** is separated from the hand of the surgeon, the second curve manipulating wire **51** is maintained in a pulled state.

As shown in FIGS. **3** to **5**, the second body member **55** includes a spring member **74** which is disposed inside the second body member **55** so as to extend to the base end along the axis **C1** and of which one end is fixed, a first substantially flat sheath attachment member **75** which is disposed in the outer peripheral surface of the base end of the second body member **55** and is attached with the pair of arm portion manipulating sheaths **67**, and a pair of first guide members (holding members) **76** which is disposed in the surface of the base end side of the second body member **55** and is provided with a pair of slits (first and second groove portions) **76a** engaging with a first oscillating portion **80** to be described later. In addition, the shape of each slit **76a** will be described later in detail.

Further, the arm manipulating portion **23** includes a first oscillating portion **80** which is connected to the first guide member **76** and oscillates on a plane (first imaginary plane) **P1** including the axis **C1**, a second oscillating portion **81** which is connected to the first oscillating portion **80** and oscillates on a plane (first imaginary plane) **P2** perpendicular to the plane **P1** including the axis **C1**, and a cylindrical manipulation stick (oscillating body) **82** which is fixed to the second oscillating portion **81**. The first oscillating portion **80**, the second oscillating portion **81**, and the manipulation stick **82** are sequentially disposed on the axis **C1** of the body portion **22**.

The first oscillating portion **80** includes a first plate-shaped wire attachment plate **85** of which both ends are attached with a base end of an arm portion manipulating wire **66**, a pair of first support members **86** which is fixed with the first wire attachment plate **85** therebetween and is provided with a pair of cylindrical shaft members (first and second convex portions) **86a** engaging with the slits **76a** of the first guide member **76**, a second substantially flat-plate-shaped sheath attachment member **87** which is disposed in the outer peripheral surfaces of the base ends of the pair of first support members **86** and is attached with the pair of arm portion manipulating sheaths **67**, and a pair of second plate-shaped guide members (holding bodies) **88** which is disposed in the surface of the base end side of the pair of first support members **86** and is provided with a pair of slits (first and second groove portions) **88a** engaging with the second oscillating portion **81** to be

described later. The first wire attachment plate **85** and the pair of first support members **86** constitute an oscillating body.

The first wire attachment plate **85**, the pair of first support members **86**, and the pair of first guide members **76** are formed to be symmetrical to each other with respect to the plane **P1**. Each of the arm portion manipulating wires **66** extends to the front end (the other side) of the arm portion **21** through one shaft member **86a** and the other shaft member **86a**.

The pair of shaft members **86a** are formed away from each other so as to protrude from the first support member **86**. In addition, when the pair of shaft members **86a** engages with the slits **76a** of the pair of first guide members **76** so that the slit **76a** guides the shaft member **86a**, the first support member **86** is regulated so as to oscillate along the plane **P1**.

In addition, the second oscillating portion **81** includes a second plate-shaped wire attachment plate **91** of which both ends are attached with the base ends of the arm portion manipulating wires **66** and a pair of second support members **92** which is fixed with the second wire attachment plate **91** interposed therebetween and is provided with a pair of cylindrical shaft members **92a** engaging with the slits **88a** of the second guide member **88**. The second wire attachment plate **91**, the pair of second support members **92**, and the manipulation stick **82** constitute an oscillating body.

The second wire attachment plate **91**, the pair of second support members **92**, and the pair of second guide members **88** are formed to be symmetrical to each other with respect to the plane **P2**. In the front end of the second wire attachment plate **91**, a pair of holding mechanisms **300** are formed so as to be symmetrical to each other with the axis **C1** interposed therebetween (particularly, see FIG. **5**). In addition, the detailed description thereof is omitted, and the holding mechanisms **300** are formed in the first wire attachment plate **85** in the same manner.

As shown in FIG. **6**, each holding mechanism **300** includes a bar-shaped shaft **302** of which one end is rotatably attached to the end of the second sheath attachment member **87** through a pin **301**, and a holding portion **304** which is rotatably attached to the second wire attachment plate **91** through a pin **303** and slidably engages with the shaft **302**.

In addition, the holding portion **304** includes a stopper casing **307** which has a substantially C-shaped section taken along the plane **P2**, a stopper base **308** which is accommodated in the stopper casing **307**, a plate-shaped stopper **309** which engages with the shaft **302**, and an elastic member **310** such as a spring which urges so that the stopper base **308** and one end **309a** of the stopper **309** are away from each other.

The shaft **302** is disposed substantially parallel to the axis **C1**. The shaft **302** and the stopper casing **307** are adapted to rotate on the plane **P2**.

Both ends of the substantially C-shaped stopper casing **307** are provided with passage holes **307a** and **307b**, and the shaft **302** is inserted through the passage holes **307a** and **307b**. In addition, an insertion hole **307c** is formed in the stopper casing **307** on the side of the axis **C1** so as to extend from the lumen of the stopper casing **307** to the front end thereof.

The stopper base **308** is formed to have a substantially E-shaped section taken along the plane **P2**. The stopper base **308** includes a first partition plate **308a**, a second partition plate **308b**, and a third partition plate **308c** which are disposed so as to be substantially perpendicular to the axis **C1** and are sequentially disposed from the front end of the stopper base to the base end thereof, where the ends on the side of the axis **C1** are integrally fixed to each other. The first partition plate **308a** extends in a direction away from the axis **C1** more than the second partition plate **308b** and the third partition plate **308c**,

and the front end thereof is provided with a passage hole **308d** for allowing the shaft **302** to be inserted therethrough. In addition, the first partition plate **308a** of the stopper base **308** is attached with the base end of the arm portion manipulating wire **66**. A gap between the second partition plate **308b** and the third partition plate **308c** is set to be thicker than the thickness of the stopper **309**.

As described below, when the arm manipulating portion **23** is manipulated, the stopper casing **307** rotates about the pin **303** relative to the shaft **302**, or the stopper base **308** moves in the inside of the stopper casing **307**. However, even in this case, each of the passage holes **307a** and **307b** of the stopper casing **307** and the passage hole **308d** of the stopper base **308** is set to have an inner diameter in which the passage holes are not locked to the shaft **302** so that the shaft **302** is freely inserted therethrough.

A passage hole **309b** is formed in one end **309a** of the stopper **309**, and the shaft **302** is inserted through the passage hole **309b**. The other end of the stopper **309** is disposed between the second partition plate **308b** and the third partition plate **308c** of the stopper base **308**, and the above-described elastic member **310** is disposed between one end **309a** of the stopper **309** and the first partition plate **308a** of the stopper base **308**. When one end **309a** of the stopper **309** is urged to the base end by the elastic member **310**, the other end of the stopper **309** is locked between the second partition plate **308b** and the third partition plate **308c** so that one end **309a** is disposed to be inclined toward the base end with respect to the other end of the stopper **309**.

Since the inner diameter of the passage hole **309b** of the stopper **309** is set to be slightly larger than the outer diameter of the shaft **302**, when the stopper **309** is disposed at a position substantially perpendicular to the shaft **302**, the shaft **302** is freely inserted through the passage hole **309b**. When the stopper **309** is inclined at a predetermined angle or more with respect to the position perpendicular to the shaft **302**, the outer peripheral edge of the passage hole **309b** is jammed in the shaft **302** so that the stopper **309** is adhered and fixed to the shaft **302**. That is, in FIG. 6, the base end of the arm portion manipulating wire **66** is fixed to the second sheath attachment member **87**.

Returning to FIGS. 3 to 5, the description is continued. Each of the arm portion manipulating wires **66** extends to the front end of the arm portion **21** through one shaft member **92a** or the other shaft member **92a**.

The pair of shaft members **92a** are formed away from each other so as to protrude from the second support member **92**. In addition, when the pair of shaft members **92a** engages with the slits **88a** of the pair of second guide members **88** so that the slit **88a** guides the shaft member **92a**, the second support member **92** is regulated to oscillate along the plane **P2**.

Further, the pair of arm portion manipulating wires **66** for bending the first curve **43** of the arm portion **21** in two directions on a line with respect to the axis is attached to both ends of the first wire attachment plate **85**, and the pair of arm portion manipulating wires **66** for bending the first curve **43** in two directions perpendicular to the two directions is attached to both ends of the second wire attachment plate **91**. In addition, a position of the first wire attachment plate **85** attached with the base ends of the pair of arm portion manipulating wires **66** moves on the plane **P1**, and a position of the second wire attachment plate **91** attached with the base ends of the pair of arm portion manipulating wires **66** moves on the plane **P2**.

Further, the other end of the spring member **74** of which one end is fixed to the second body member **55** is fixed to a perforation hole (oscillating-body-side channel) **82a** coaxially

formed with the manipulation stick **82** disposed on the axis **C1** through a gap between the pair of first support members **86** and a gap between the pair of second support members **92**. Likewise, the channel **25** is formed so as to include the perforation hole (insertion-portion-side channel) **21a** (see FIG. 2) formed in the arm portion **21**, the inside of the first body member **54**, the inside of the second body member **55**, and the inner surface of the spring member **74**, and the treatment tool **26** is inserted through the channel **25** up to the arm portion **21**.

As described above, a relationship between the slit **76a** of the first guide member **76** oscillating the first oscillating portion **80** and the shaft member **86a** of the first support member **86** and a relationship between the slit **88a** of the second guide member **88** oscillating the second oscillating portion **81** and the shaft member **92a** of the second support member **92** are set to have the same configuration as each other when rotating by 90° in a direction seen from the axis **C1**. That is, in the arm manipulating portion **23** of the arm mechanism **20** according to this embodiment, the oscillating body and the holding body make a pair, and two pairs thereof are disposed at positions shifted in the direction of the axis **C1** so as to be perpendicular to the oscillating planes **P1** and **P2**. In addition, the oscillating body including the first wire attachment plate **85** and the pair of first support members **86** and the holding body including the second guide member **88** are integrally formed with each other.

Therefore, hereinafter, a relationship between the slit **88a** and the shaft member **92a** will be described. In addition, only for convenience of description, the pair of slits **88a** and the shaft members **92a** are described as slits **88a1** and **88a2** and shaft members **92a1** and **92a2** having separate reference numerals.

When the first curve **43** of the arm portion **21** is formed in a shape along the axis of the arm portion **21**, as shown in FIG. 5, the pair of shaft members **92a1** and **92a2** are disposed so as to be symmetrical to each other with respect to the axis **C1** of the body portion **22** and protrudes in a direction perpendicular to the plane **P2** when viewed from a plane perpendicular to the plane **P2**.

Here, as shown in FIGS. 3 to 5, a manipulation reference plane **P3** is set so as to be perpendicular to the axis **C1** and to pass through the center point (start point) **Q1** of the shaft member **92a1** and the center point (start point) **Q2** of the shaft member **92a2**. In addition, as shown in FIG. 3, planes (second imaginary planes) **P4** are set in the inner surfaces of the pair of second guide members **88**.

At this time, the pair of planes **P4** is parallel to the plane **P2**, and the pair of second guide members **88** is disposed on the plane **P2**.

In addition, the slit **88a1** is formed in an elongate hole shape so as to extend to the base end (one side) of the body portion **22** along a circular arc **L2** passing through the position of the perforation hole from the center point **Q1** as one end about the shaft member **92a2**. In the same manner, the slit **82a2** is formed in an elongate hole shape so as to extend to the base end along a circular arc **L1** passing through the position of the perforation hole from the center point **Q2** as one end about the shaft member **92a1**. In addition, when the first curve **43** of the arm portion **21** is formed in a shape taken along the axis, and the manipulation stick **82**, the first oscillating portion **80**, and the second oscillating portion **81** are disposed on the axis **C1** of the body portion **22** (hereinafter, the position of the manipulation stick **82** is referred to as "a neutral position"), predetermined tension acts on four arm portion

manipulating wires 66 so that the shaft member 92a1 and the shaft member 92a2 are respectively located at ends of the center points Q1 and Q2.

Further, as shown in FIG. 1, since the arm manipulating portion 23 is disposed in the vicinity of the switch 30 and the angle knob 31 of the endoscope manipulating portion 2, for example, one surgeon is capable of manipulating the arm manipulating portion 23, the switch 30, the angle knob 3, and the like using one hand while supporting the endoscope manipulating portion 2 using the other hand.

Next, a sequence of cutting, for example, a target tissue inside a digestive canal by using the endoscope device 1 with the above-described configuration will be described.

First, the endoscope inserting portion 3 is inserted from a patient's mouth into a body while observing a forward situation of the endoscope inserting portion 3 through the observation mechanism 6 and the monitor 15 by illuminating the forward area of the endoscope inserting portion 3 using the illumination mechanism 5. At this time, the third curve 32 of the endoscope inserting portion 3 is inserted into the body while being curved with respect to the axis C0 by an operation of rotating the angle knob 31 if necessary.

At this time, the arm mechanisms 20 may not be inserted through the lumens 8 and 9.

As shown in FIG. 2, when it is observed that the front end of the endoscope inserting portion 3 arrives at a target tissue K by using the monitor 15, the position of the front end of the endoscope inserting portion 3 is fixed, and the arm portions 21 having the treatment tools 26 inserted through the first and second lumens 8 and 9 are inserted. Then, when the slide members 58 of the engagement mechanisms 50 engage with the opening metals 17 of the clamp openings 12 and 13, the body portions 22 of the arm mechanisms 20 are attached to the clamp openings 12 and 13. Then, each of the arm portions 21 protrudes from the passageway 4a of the side surface of the endoscope inserting portion 3 by a predetermined length.

Here, the base ends of the pair of second curve manipulating wires 51 are pulled by the bar member 71 by rotating the second curve manipulating ring 27 in a direction depicted by E1, and the pair of second curves 42 are fixed while being bent in an S shape so as to face each other. At this time, as shown in FIG. 7 showing the image of the monitor 15, a so-called triangular arrangement is formed such that the front ends of the treatment tools 26 are close to each other and the base ends of the arm portions 21 are opened, thereby easily performing a surgical technique.

In addition, in this embodiment, since the substantially circular hole portion 58a of the slide member 58 of the body portion 22 engages with the circular flange portion 17a of the opening metal 17, it is possible to adjust the curving direction of the arm portion 21 by rotating the arm manipulating portion 23 and the body portion 22 of the arm mechanism 20 about the axis C1 of the body portion 22 relative to each of the lumens 8 and 9. Independently from this rotation, it is possible to rotate the treatment tool 26 about the axis relative to the arm mechanism 20. If necessary, the surgeon manipulates the manipulation stick 82 so as to adjust a curving direction of the arm portion 21 and a direction of the treatment tool 26 as described later in detail.

Next, the surgeon performs a treatment on the target tissue K. First, the treatment tool 26 is reciprocated relative to the manipulation stick 82 of one arm mechanism 20 or the manipulation stick 82 is oscillated relative to the body portion 22 in order to grip the endoscope manipulating portion 2 using one hand and to adjust the position or direction of the front end of the arm portion 21 using the other hand. When the treatment tool 26 is reciprocated relative to the manipulation

stick 82, it is possible to adjust a protruding length of the treatment tool 26 from the front end of the arm portion 21. Then, when the manipulation stick 82 is oscillated relative to the body portion 22, as described below, it is possible to bend the first curve 43 in four directions with respect to the axis of the arm portion 21.

That is, as shown in FIG. 8, for example, when the manipulation stick 82 of the arm mechanism 20 moves down toward the slit 88a1, the second wire attachment plate 91 rotates about the shaft member 92a1.

At this time, in the holding mechanism 300 disposed in the slit 88a1, as shown in FIG. 9, the second wire attachment plate 91 and the pin 303 rotate in a direction depicted by the arrow in the drawing. Then, the front-end-side inner surface of the stopper casing 307 comes into contact with the first partition plate 308a of the stopper base 308 so as to move the stopper base 308 toward the base end. For this reason, in the state where the position of one end 309a of the stopper 309 is substantially maintained, the second partition plate 308b moves the other end of the stopper 309 toward the base end so that the stopper 309 is substantially perpendicular to the shaft 302, and hence the operation of fixing the stopper 309 to the shaft 302 is canceled.

When the surgeon's hand is release from the manipulation stick 82, the second wire attachment plate 91 is slightly inclined toward the slit 88a2 due to a difference in the tension (which indicates that the tension of the pulled arm portion manipulating wire 66 becomes strong) of two arm portion manipulating wires 66 attached to the second wire attachment plate 91. Accordingly, in the state where the position of one end 309a of the stopper 309 is substantially maintained, the other end of the stopper 309 moves toward the front end so that the outer peripheral edge of the passage hole 309b is jammed in the shaft 302, and the stopper 309 is fixed to the shaft 302.

Then, as shown in FIG. 8, the arm portion manipulating wire 66 attached to the end of the second wire attachment plate 91 on the side opposite the side where the manipulation stick 82 moves down is pulled in the state where a radius is a distance D1 from the center of the shaft member 92a1 to the attachment position of the arm portion manipulating wire 66. For this reason, compared with the case where the second wire attachment plate 91 rotates about the center point between the shaft member 92a1 and the shaft member 92a2, it is possible to pull the arm portion manipulating wire 66 in a longer distance. On the other hand, the arm portion manipulating wire 66 attached to the end of the second wire attachment plate 91 on the side where the manipulation stick 82 moves down is pushed in while having a radius set to a distance D2 from the center of the shaft member 92a1 to the attachment position of the arm portion manipulating wire 66. For this reason, compared with the case where the second wire attachment plate 91 rotates about the above-described center point, it is possible to suppress the loosening amount of the arm portion manipulating wire 66.

In addition, when the manipulation stick 82 moves down toward the slit 88a2 in this state, as shown in FIG. 10, the second wire attachment plate 91 rotates in a direction depicted by the arrow in the drawing together with the pin 303. Then, the inner surface of the base end side of the stopper casing 307 comes into contact with one end 309a of the stopper 309 so as to move the base-end-side portion of the stopper 309 to the front end from a plane P11 extending from the inner surface of the base end side surface of the third partition plate 308c as shown in FIG. 9. For this reason, as shown in FIG. 10, in the state where the position of the other end of the stopper 309 is substantially maintained, the stopper

casing 307 moves one end 309a of the stopper 309 toward the front end so that the stopper 309 is substantially perpendicular to the shaft 302, and hence the operation of fixing the shaft 302 to the stopper 309 is canceled.

In this manner, the second wire attachment plate 91 rotates about the shaft member 92a1.

In this embodiment, since the treatment tool 26 is reciprocated relative to the manipulation stick 82, the oscillating center of the manipulation stick 82 is located at a fixed position in the direction of the axis C1 of the body portion 22 regardless of the reciprocating movement of the treatment tool 26. That is, as shown in FIG. 1, even when the treatment tool 26 is reciprocated so that the manipulation end is located at the position Z1 or the position Z2, the position of the oscillating center Z3 of the treatment tool 26 does not change, which has such a merit that a natural oscillating movement can be performed. However, when the treatment tool 26 is oscillated in the state where the treatment tool 26 is withdrawn to the base end as much as possible, that is, in the state where the manipulation end of the treatment tool 26 is withdrawn as much as possible, the movement range of the manipulation end of the treatment tool 26 becomes wide, which may cause such a problem that the treatment tool 26 contacts with the surgeon or the endoscope manipulating portion 2.

Further, in this embodiment, since the first curve 43 of the arm portion 21 is formed in a shape of the first curve 43 taken along the axis of the arm portion 21 when the manipulation stick 82 is located at the neutral position, it is possible to easily determine the position of the manipulation stick 82 corresponding to the state where the first curve 43 is formed in a linear shape. In addition, when the first curve 43 of each arm portion 21 is formed in a shape taken along the axis of the arm portion, and the first oscillating portion 80 and the second oscillating portion 81 are disposed at positions taken along the axis C1 of the body portion 22, uniform tension acts on each of four arm portion manipulating wires 66. For this reason, the first curve 43 of the arm portion 21 is easily disposed at the stable position taken along the axis, and the manipulation stick 82 is easily disposed at the stable neutral position.

Then, the surgeon manipulates the base end of the treatment tool 26 so that the front end of the treatment tool 26 grips and pulls the target tissue K, and maintains one of arm mechanisms 20 in this state.

In addition, the surgeon manipulates the other arm mechanism 20 in the same manner so that the treatment tool 26 cuts the target tissue K.

In this embodiment, as shown in FIG. 2, when the arm portions 21 protrude forward from the endoscope inserting portion 3 so as to bend the second curve 42 and the first curve 43, it is possible to shorten a length A3 from the front end of the treatment tool 26 to the front end surface 3a of the endoscope inserting portion 3, and thus to perform the treatment in the inside of a comparatively narrow space such as a digestive canal.

In this manner, in the arm manipulating portion 23 according to this embodiment, the pair of shaft members 92a move in the inside of the pair of slits 88a formed on the plane P4 of the second guide member 88. For this reason, it is possible to stably oscillate the manipulation stick 82, moving on the plane P2 parallel to the plane P4, along the slit 88a.

In the arm manipulating portion 23, the shaft member 92a1 rotates in the rotation direction from the center point Q1 of the slit 88a1 on the plane P2, and the shaft member 92a2 moves inside the slit 88a2 so that the manipulation stick 82 oscillates in the rotation direction from the center point Q1. However,

this movement can be changed such that the shaft member 92a2 rotates in the rotation direction from the center point Q2 of the slit 88a2, and the shaft member 92a1 moves inside the slit 88a1 so that the manipulation stick 82 oscillates in the rotation direction from the center point Q2. Accordingly, it is possible to further stabilize the oscillation of the manipulation stick 82.

In addition, since the oscillating center of the manipulation stick 82 is suppressed from changing from one of the shaft member 92a1 and the shaft member 92a2 to the other thereof when the manipulation stick 82 is inclined toward one of them at the neutral position, it is possible to further improve the operability of the manipulation stick 82.

Since the manipulation stick 82 is disposed between the pair of second guide members 88, it is possible to further reliably oscillate the manipulation stick 82 on the plane P2.

Since the oscillating body and the holding body make a pair in the arm manipulating portion 23, and two pairs thereof are disposed so that the oscillating planes of two pairs are perpendicular to each other, it is possible to oscillate the manipulation stick 82 in two directions which are perpendicular to each other.

In addition, in the arm mechanism 20 according to this embodiment, when the manipulation stick 82 is oscillated in the rotation direction from the position Q1 or the position Q2 on the plane P2, it is possible to change the pulled arm portion manipulating wires 66, and to change the curving direction of the first curve 43.

Further, since the uniform tension acts on the arm portion manipulating wires 66 at the neutral position, when the external force is applied to the manipulation stick 82, the manipulation stick 82 is located on the axis C1 of the body portion 22. At this time, the shaft member 92a1 is located at the center point Q1 of the slit 88a1, and the shaft member 92a2 is located at the center point Q2 of the slit 88a2. Accordingly, it is possible to easily change the oscillating center of the manipulation stick 82.

Since the perforation hole 82a of the manipulation stick 8 communicates with the perforation hole 21a of the arm portion 21 so as to form the channel 25, it is possible to perform the treatment by inserting the treatment tool 26 into the channel 25 of the arm mechanism 20.

Since the arm portions 21, through which the treatment tools 26 are inserted, protrude from the front ends of the lumens 8 and 9 by respectively inserting the arm mechanisms 20 through the first and second lumens 8 and 9 formed in the endoscope device 1, it is possible to perform various treatments using the treatment tools 26 while bending the first curves 43 of the arm mechanisms 20.

In addition, since the arm mechanism 20 is attached to the endoscope device 1 in the state where the arm portion 21 is inserted through the first lumen 8 or the second lumen 9, it is possible to integrate the endoscope device 1 with the arm mechanism 20, and thus to improve the operability of the endoscope device.

Since the arm portions 21 of the arm mechanisms 20 are rotated in the rotation direction about the axis thereof at the front ends of the first lumen 8 and the second lumen 9, it is possible to improve the treatment operability using the endoscope device 1.

Since the first wire attachment plate 85 and the second wire attachment plate 91 are provided with the holding mechanisms 300, it is possible to easily bend the first curve 43 of the arm mechanism 20, and to maintain the curve state of the first curve 43 bent by the surgeon. Then, one surgeon is capable of easily manipulating the endoscope device 1.

In addition, as described above, since the endoscope device 1 according to this embodiment uses two arm mechanisms 20, it is possible to perform a complex treatment.

Further, as in the modified example shown in FIG. 11, the first body member 54 according to this embodiment may be formed by double tubes, that is, a body's base end side member 96 and a body-front-end-side member 97 which are formed in a cylindrical shape so as to have different diameters, and the inner peripheral surface of the body-base-end-side member 96 and the outer peripheral surface of the body-front-end-side member 97 coming into contact with each other may be provided with positioning portions 96a and 97a used for determining the relative position in the direction of the axis C1. In this modified example, the positioning portions 96a and 97a are formed in an concavity and a convexity so as to be continuous in the direction of the axis C1 and to be fitted to each other.

The arm portion manipulating sheaths 67 are inserted through the perforation holes 55a formed in the second body member 55.

In addition, the body-base-end-side member 96 is attached with a fixing mechanism 500 for fixing the body-base-end-side member 96 to the body-front-end-side member 97 in the direction of the axis C1. The fixing mechanism 500 includes a lever 501 which is rotatably attached to the body-base-end-side member 96 through a pin 501a and an urging member 502 which urges the lever 501 in the rotation direction of the pin 501a. The lever 501 is provided with a claw portion 501b, and the claw portion 501b is adapted to be fitted to the positioning portion 96a of the body-base-end-side member 96. In addition, the lever 501 is urged by the urging member 502 so that the claw portion 501b is fitted to the positioning portion 96a.

The body-base-end-side member 96, the body-front-end-side member 97, and the fixing mechanism 500 constitute a length adjusting mechanism 95.

FIG. 11 shows a state where the body-base-end-side member 96 is fixed to the body-front-end-side member 97 in the direction of the axis C1. When a lever pressing portion 501c formed in the lever 501 is pushed toward the axis C1 against the force of the urging member 502, as shown in FIG. 12, it is possible to move the claw portion 501b and the positioning portion 96a to be away from each other. In this state, when the body-base-end-side member 96 is reciprocated in the direction of the axis C1, it is possible to change the protruding length of the treatment tool 26.

In addition, since the arm portion manipulating sheath 67 is inserted through the perforation hole 55a formed in the second body member 55 while ensuring a sufficient length, even when the body-base-end-side member 96 is reciprocated relative to the body-front-end-side member 97, it is possible to prevent the arm portion manipulating sheath 67 from continuously extending.

In this modified example, since the length of the body portion 22 of the arm mechanism 20 in the direction of the axis C1 can be adjusted, it is possible to adjust the protruding length of the treatment tool 26 from the front end of the arm portion 21 by using the positional relationship between the body-base-end-side member 96 and the body-front-end-side member 97 without changing the protruding length of the treatment tool 26 closer to the base end than the manipulation stick 82 as in the first embodiment.

In addition, since the oscillating center of the manipulation stick 82 is reciprocated in the direction of the axis C1, as shown in FIG. 13, it is possible to allow the movement width of the manipulation end of the treatment tool 26 in a direction perpendicular to the direction of the axis C1 to be uniform

regardless of the reciprocation state of the treatment tool 26 even when the manipulation end is located at the position Z4 or Z5.

However, since the position of the oscillating center deviates due to the reciprocation of the treatment tool 26, the surgeon may feel uncomfortable by manipulating the device.

Note that, in this modified example, even when the body-base-end-side member 96 rotates in the rotation direction about the axis C1 relative to the body-front-end-side member 97, this rotation is absorbed between the engagement mechanism 50 and the clamp opening 12, and hence the arm mechanism 20 does not rotate.

Also, even when the arm mechanism 20 moves in the direction of the axis C1, since the lengths of the manipulating wire 66 and the arm portion manipulating sheath 67 are fully-extended, lack of both lengths does not occur. At this time, when the arm portion 21 is fixed to the front end of the endoscope inserting portion, the arm portion 21 does not protrude from the front end of the endoscope inserting portion due to the loosening state of the manipulating wire 66 and the arm portion manipulating sheath 67.

Note that, in this embodiment, each of the pair of slits 70a and the pair of the slits 88a is formed in a circular arc shape of which a center is the center point Q1. However, the shape of the slit 88a is not limited thereto, but may be formed in a shape closer to each other in a direction away from the plane P3 to the base end of the body portion 22. The same applies to the slit 70a.

Further, in this embodiment, the arm manipulating portion 23 is provided with two pairs of the oscillating body and the holding body, where the oscillating body and the holding body make a pair. However, a pair of the oscillating body and the holding body may be disposed in the arm manipulating portion 23.

Second Embodiment

Next, a second embodiment of the invention will be described. Since the same reference numerals will be given to the same constituents as those of the above-described embodiment, the description thereof will be omitted, and only the differences will be described.

As shown in FIGS. 14 and 15, an arm mechanism 100 according to this embodiment includes the arm portion 21, the body portion 22, and an arm manipulating portion 103 which is manipulated to curve the front end of the arm portion 21.

The second body portion 55 of the body portion 22 includes the spring member 74, a first sheath attachment member 104 which is disposed in the outer peripheral surface of the base end of the second body member 55, and a pair of first plate-shaped guide members 105 which is disposed in the surface of the base end side of the second body member 55 and is provided with a perforation hole 105a so as to rotatably support a first oscillating portion 108 to be described later.

The pair of arm portion manipulating sheaths 67, through which the arm portion manipulating wires 66 are inserted, is attached to both ends of the first sheath attachment member 104.

In addition, the arm portion manipulating portion 103 includes the first oscillating portion 108 which is rotatably supported to the pair of first guide members 105 so as to oscillate on the plane P1 including the axis C1, the second oscillating portion 109 which is connected to the first oscillating portion 108 so as to oscillate on the plane P2 perpendicular to the plane P1 including the axis C1, and the cylindrical manipulation stick 82 which is fixed to the second oscillating portion 109.

The first oscillating portion **108** includes a first plate-shaped wire attachment portion **112** of which both ends are attached with the base ends of the arm portion manipulating wires **66**, a pair of first support members **113** which is fixed with the first wire attachment portion **112** interposed therebetween, a second sheath attachment member **114** which is disposed in the outer peripheral surfaces of the base ends of the pair of first support members **113** and is attached with the pair of arm portion manipulating sheaths **67**, and a pair of second plate-shaped guide members **115** which is disposed in the surfaces of the base end side of the pair of first support members **113** and is provided with perforation holes **115a** so as to rotatably support the second oscillating portion **109**.

Each of the first support members **113** is provided with a perforation hole **113a** which communicates with the perforation hole **105a** of the first guide member **105**. In addition, both ends of the second sheath attachment member **114** are attached with the pair of arm portion manipulating sheaths **67** through which the arm portion manipulating sheaths **66** are inserted.

In addition, a pair of pin members **120** is inserted through the perforation holes **105a** of the first guide members **105** and the perforation holes **113a** of the first support members **113** so that the first oscillating portion **108** rotates on the plane **P1** about the pin member **120** relative to the first guide member **105**.

The second oscillating portion **109** includes a second plate-shaped wire attachment portion **118** of which both ends are attached with the base ends of the arm portion manipulating wires **66**, and a pair of second support members **119** which is fixed with the second wire attachment portion **118** interposed therebetween and is provided with perforation holes **119a** communicating with the perforation holes **115a** of the second guide members **115**.

In addition, the pair of pin members **120** is inserted through the perforation holes **115a** of the second guide members **115** and the perforation holes **119a** of the first support members **119** so that the second oscillating portion **109** rotates on the plane **P2** about the pin member **120** relative to the second guide members **115**.

Here, since the first wire attachment portion **112** and the second wire attachment portion **118** have the same configuration, the configuration of the second wire attachment portion **118** will be described with reference to FIG. **15**.

The second wire attachment portion **118** includes a fixing member **122** which fixes the base ends of the arm portion manipulating wires **66**, first and second winding members **123** and **124** around which the arm portion manipulating wires **66** are wound, and regulation members **125** and **126** which prevent the arm portion manipulating wires **66** from protruding to the outside. In addition, the arm portion manipulating wire **66** wound around the second winding member **124** extends to the inside of the arm portion manipulating sheath **67** attached to the second sheath attachment member **114**.

In the arm mechanism **100** having the above-described configuration, for example, as shown in FIG. **16**, when the manipulation stick **82** of the arm mechanism **100** falls down along the second wire attachment portion **118**, the second wire attachment portion **118** rotates on the plane **P2** about the pin member **120**. In addition, the arm portion manipulating wire **66** attached to the end of the second wire attachment portion **118** opposite to where the manipulation stick **82** moves down is drawn out in the state where a radius is a distance **D4** from the center of the pin member **120** to the position of the second winding member **124** where the arm portion manipulating wire **66** is drawn out. On the other hand,

the arm portion manipulating wire **66** attached to the end of the second wire attachment portion **118** on the side where the manipulation stick **82** falls down is pushed in while having a radius set to a distance **D3** from the center of the pin member **120** to the position of the second winding member **124** where the arm portion manipulating wire **66** is drawn out. At this time, in this embodiment, since the periphery of the second winding member **124** is provided with a space for accommodating the remaining arm portion manipulating wire **66**, it is possible to manipulate the arm portion manipulating wire **66** while suppressing the arm portion manipulating wire **66** from being loosened in other portions.

Third Embodiment

Next, a third embodiment of the invention will be described. Since the same reference numerals will be given to the same constituents as those of the above-described embodiment, the description thereof will be omitted, and only the different points will be described.

As shown in FIG. **17**, an arm manipulating portion **133** of an arm mechanism **130** according to this embodiment includes a first oscillating portion **134** which oscillates on the plane **P1** including the axis **C1** relative to the body portion **22**, a second oscillating portion **135** which is connected to the first oscillating portion **134** and oscillates on the plane **P2** perpendicular to the plane **P1** including the axis **C1**, and the cylindrical manipulation stick **82** which is fixed to the second oscillating portion **135**.

Even in this embodiment, the arm portion manipulating wire **66** on the side opposite to the side where the manipulation stick **82** falls down is pulled, but four arm portion manipulating wires **66** are provided with four link mechanisms **136a** to **136d** having the same configuration in order to increase the pulling amount when the manipulation stick **82** is inclined by a predetermined angle.

The link mechanism **136a** and the link mechanism **136d** (not shown in figure) are included in the first oscillating portion **134**. Then, the pair of link mechanisms **136a** and **136d** is disposed on both planes parallel to the panel **P1** and away from the plane **P1** by a predetermined distance so as to be symmetrical to each other with respect to the axis **C1** of the body portion **22**, and is operated on the respective planes so as to pull or push the base end of the arm portion manipulating wire **66**. In addition, the link mechanism **136b** and the link mechanism **136c** are included in the second oscillating portion **135**. Then, the pair of link mechanisms **136a** and **136d** is disposed on both planes parallel to the plane **P2** and away from the plane **P2** by a predetermined distance so as to be symmetrical to each other with respect to the axis **C1** of the body portion **22**, and is operated on the respective planes so as to pull or push the base end of the arm portion manipulating wire **66**.

Next, the link mechanism **136a** of the link mechanisms will be given as examples and schematically described. As shown in FIG. **18**, the manipulation stick **82** is supported so as to be rotatable about the point **P1**, and a pin member **140** is fixed to the manipulation stick **82**. One end of a first link **141** is supported so as to be rotatable about the point **P2**, and the inside thereof is provided with a slit **141a** engaging with the pin member **140**. One end of a second link **142** is supported so as to be rotatable about the point **P1**, and the other end thereof is fixed to the base end of the arm portion manipulating wire **66**. Then, the other end of the first link **141** is locked to the vicinity of one end of the second link **142**.

In the link mechanism **136a** having the above-described configuration, as shown in FIG. **19**, when the manipulation

stick **82** is inclined in a direction depicted by the arrow **Y1**, the pin member **140** rotates about the point **P1** so as to move inside the slit **141a** in a direction depicted by the arrow **Y2**, thereby pushing up the other end of the first link **141** in a direction depicted by the arrow **Y3**. Then, the vicinity of one end of the second link **142** is locked to the other end of the first link **141**, and the other end of the second link **142** is pushed up in a direction depicted by the arrow **Y4** so as to pull the base end of the arm portion manipulating wire **66**.

In addition, a case will be examined in which the manipulation stick **82** and the second link **142** are fixed to each other without the link mechanisms described so far and the manipulation stick **82** is supported so as to be rotatable about the point **P1**. In this case, since the second link **142** rotates about the point **P1** by an angle corresponding to a degree that the manipulation stick **82** rotates about the point **P1**, the other end of the second link **142** is pushed up in a direction depicted by the arrow **Y5**, and the pushing-up amount is smaller than that when the link mechanism is used.

Likewise, in the link mechanisms **136a** to **136d** according to this embodiment, it is possible to increase the pulling amount of the arm portion manipulating wire **66** with respect to the inclined angle of the manipulation stick **82**.

In addition, when the manipulation stick **82** is inclined in a direction opposite to the direction depicted by the arrow **Y1** in the state shown in FIG. **18**, the pin member **140** rotates about the point **P1** so as to move inside the slit **141a** in a direction opposite to the direction depicted by the arrow **Y2**, thereby pushing down the other end of the first link **141** in a direction opposite to the direction depicted by the arrow **Y3**. Then, the vicinity of one end of the second link **142** is pushed down by the other end of the first link **141**, and the other end of the second link **142** is pushed down in a direction opposite to the direction depicted by the arrow **Y4** so as to push in the base end of the arm portion manipulating wire **66**.

In addition, in this embodiment, the link mechanisms **136a** to **136d** adopt a two-stage link structure, but the link structure may have several stages not less than one stage.

Fourth Embodiment

Hereinafter, another embodiment of the endoscope device according to the above-described embodiment will be described. Since the same reference numerals will be given to the same constituents as those of the above-described embodiment, the description thereof will be omitted, and only the different points will be described. In addition, for convenience of description, the partial shape in the drawings is omitted.

As shown in FIG. **20**, an endoscope inserting portion **202** of an endoscope device **201** according to this embodiment is inserted through a lumen of an over tube (medical instrument) **220**, and the front end of the endoscope inserting portion **202** protrudes forward from an opening formed in the front end of the over tube **220**.

A lumen **205** is formed in a clamp opening **204** disposed in the endoscope manipulating portion **203** of the endoscope device **201**, and the lumen **205** extends to a front end surface of the endoscope inserting portion **202** along the endoscope inserting portion **202**.

For example, a treatment tool inserting portion **231** of a first treatment tool **230** as a high-frequency knife is inserted through the lumen **205**, and the front end of the treatment tool inserting portion **231** protrudes forward from the front end of the endoscope inserting portion **202**. The base end of the first treatment tool **230** is provided with a treatment tool manipulating portion **232**, and the treatment tool manipulating por-

tion **232** includes a manipulation portion body **232a** which is attached to the base end of the treatment tool inserting portion **231** and a manipulation member **232b** which is slidable on the manipulation portion body **232a** in the longitudinal direction. In addition, when the manipulation member **232b** is pushed into the manipulation portion body **232a**, a high-frequency current flows from a high frequency generating device (not shown in figure) to a knife member **233** disposed in the front end of the treatment tool inserting portion **231**.

Since the treatment tool manipulating portion **232** is disposed in the endoscope manipulating portion **203** of the endoscope device **201**, one surgeon is capable of reciprocating and rotating the first treatment tool **230** relative to the clamp opening **204** of the endoscope manipulating portion **203**, and manipulating the knife member **233**. In addition, in the past, an assistant assisting the surgeon rotated and manipulated the treatment tool.

The base end of the over tube **220** is provided with a clamp opening **221**, and the body portion **22** of the arm mechanism **20** of the above-described embodiment is attached to the clamp opening **221**. In addition, the arm portion **21** of the arm mechanism **20** is inserted through the lumen of the over tube **220**, and the front end of the arm portion **21** protrudes forward from the opening formed in the front end of the over tube **220**. The front end of the over tube **220** may have a curve function. The arm portion **21** may be separably attached to the over tube **220**. The arm mechanism **20** may not be provided with the second curve **42**.

For example, a treatment tool inserting portion **241** of a second treatment tool **240** such as a gripping clamp is inserted through the channel **25** formed in the arm mechanism **20**. The base end of the second treatment tool **240** is provided with a treatment tool manipulating portion **242**, and the treatment tool manipulating portion **242** includes a manipulation portion body **242a** which is attached to the base end of the treatment tool inserting portion **241** and a manipulation member **242b** which is slidable on the manipulation portion body **242a** in the longitudinal direction. Then, when the manipulation member **242b** is pushed into or pulled out from the manipulation portion body **242a**, a gripping portion **243** disposed in the front end of the treatment tool inserting portion **241** is opened or closed.

In addition, the surgeon is capable of reciprocating or rotating the second treatment tool **240** relative to the arm mechanism **20**, and manipulating the gripping portion **243**.

The treatment using the endoscope device **201** and the over tube **220** having the above-described configuration is performed as follows.

First, in the inside of a patient's body, the treatment tool inserting portion **241** of the second treatment tool **240** protrudes from the front end of the arm portion **21**, the treatment tool manipulating portion **242** of the second treatment tool **240** is manipulated so as to grip the target tissue **K2** using the gripping portion **243**, and then the manipulation stick **82** is oscillated through the treatment tool manipulating portion **242** so as to bend the first curve **43** and to pull the target tissue **K2**.

Next, the treatment tool inserting portion **231** of the first treatment tool **230** protrudes from the lumen **205** of the endoscope device **201**, and the treatment tool manipulating portion **232** is manipulated so as to cut the target tissue **K2**.

In the endoscope device **201** having the above described configuration according to this embodiment, it is possible to observe an area on the side of the front end of the endoscope inserting portion by inserting the endoscope inserting portion **202** of the endoscope device **201** through the lumen of the over tube **220**.

In addition, since the target tissue K2 is pulled and cut, it is possible to easily perform the cutting operation. Further, since it is possible to use two treatment tools, that is, the second treatment tool 240 for the pulling operation and the first treatment tool 230 for the cutting operation, it is possible to more easily perform the cutting operation.

In addition, as below, one surgeon can perform the above-described treatment. That is, for example, the surgeon performs a manipulation operation (an operation of twisting the endoscope inserting portion 202, an operation of manipulating an angle of the scope, and the like) the endoscope manipulating portion 203 using a left hand, and reciprocates the endoscope inserting portion 202 or manipulates the treatment tool manipulating portion 232 of the first treatment tool 230, the treatment tool manipulating portion 242 of the second treatment tool 240, and the arm mechanism 20 while holding the endoscope inserting portion 202 using a right hand.

Likewise, since the manipulation operation (a rotation operation or an opening/closing operation of the gripping portion in the gripping clamp) performed by an assistant can be performed by one surgeon, it is possible to solve the difficulty of cooperating with the assistant, and thus to perform the treatment by only a few surgeons.

Fifth Embodiment

Next, a fifth embodiment of the invention will be described. Since the same reference numerals will be given to the same constituents as those of the above-described embodiment, the description thereof will be omitted, and only the different points will be described.

As shown in FIG. 21, in an endoscope device 251 according to this embodiment, a clamp opening 252 is provided instead of the clamp opening 204 of the endoscope device 201 according to the above-described embodiment, the arm portion 21 of the arm mechanism 20 is inserted through the lumen 205, and the body portion 22 is attached to the clamp opening 252. In addition, the front end of the arm portion 21 protrudes forward from the front end of the endoscope inserting portion 202.

The treatment tool inserting portion 231 of the first treatment tool 230 is inserted through the channel 25 formed in the arm mechanism 20, and the front end of the treatment tool inserting portion 231 protrudes forward from the front end of the arm portion 21. In addition, it is desirable that the arm mechanism 20 is provided with the second curve 42.

In the endoscope device 251 having the above-described configuration according to this embodiment, it is possible to exhibit the same advantage as that of the above-described embodiment. In addition, it is possible to curve the front end of the treatment tool inserting portion 231 of the first treatment tool 230 by using the arm mechanism 20 attached to the clamp opening 252.

In the past, since the treatment such as the cutting operation was performed by moving the treatment tool inserted through the endoscope together with the endoscope, the FOV of the endoscope moved during the treatment. In this embodiment, since the treatment is performed by curving the first curve 43 of the arm mechanism 20 attached to the clamp opening 252, it is possible to improve the operability of the surgeon by suppressing the movement of the FOV during the treatment.

So far, the embodiment has been described in which the first and second lumens 8 and 9 communicate with the passageways 37a formed in the side surface of the endoscope inserting portion 3 of the endoscope device, and two arm mechanisms are inserted through the lumens 8 and 9. However, when the positions of the passageways of the lumens are

changed or the types of the treatment tools inserted through the lumens are changed, it is possible to perform various types of surgical techniques as described below.

For example, as shown in FIG. 22, the first lumen 8 may be inserted through the passageway formed in the front end surface of the endoscope inserting portion 3, and the arm portion 21 without the second curve may be inserted through the first lumen 8. When the arm portion 21 is adapted to be bent just by the first curve, it is possible to shorten the rigid range which cannot be bent in the arm portion 21, and thus to perform the treatment in the inside of a comparatively narrow space such as a digestive canal.

In addition, the configuration shown in FIG. 22 may be used. That is, a passageway 151 is formed in a side surface of a front end of an endoscope inserting portion 150. Then, the passageway 151 is provided with a raising stand 154 rotated by an endoscope manipulating wire 153 inserted through a second lumen 152. With the above-described configuration, it is possible to bend the front end of the arm portion 21 inserted through the first lumen 8 by using the raising stand 154.

In addition, when the treatment tool 26 is configured as the gripping clamp, it is possible to elevate and pull a tissue such as a mucous membrane N by using the treatment tool 26. Further, when the high-frequency treatment tool is inserted through the arm portion 21 and is operated, it is possible to simply perform the treatment.

In addition, as shown in FIG. 24, an endoscope inserting portion 157 may be provided with a lumen 158 communicating with a passageway formed in the front end surface of the endoscope inserting portion, and a gripping clamp 159 may be inserted through the lumen so as to be movable in a reciprocating manner. It is possible to perform a treatment in such a manner that the mucous membrane N or the like is gripped by the gripping clamp 159 and is reciprocated. Further, the treatment may be performed by using a high-frequency treatment tool (not shown in figure) in the state shown in FIG. 24.

As shown in FIG. 25, in the case where the mucous membrane N or the like is elevated and pulled by the treatment tool 26 as the gripping clamp, it is desirable that the arm portion 21 is disposed so as to protrude forward from a position (upper position) of the endoscope inserting portion 157 away from the mucous membrane N. This is because the mucous membrane N or the like can be elevated and pulled up to a higher position compared with the case where the arm portion 21 protrudes forward from a position close to the mucous membrane N as shown in FIG. 26.

As shown in FIG. 27, in the case where the endoscope inserting portion 157 enters a lower portion of a tissue S, it is desirable that the arm portion 21 be disposed so as to protrude forward from the endoscope inserting portion 157 on the side of the tissue S (upper position). With the above-described disposed state, it is possible to ensure an FOV of a forward area or a treatment area by supporting the tissue S using the arm portion 21.

In the above-described embodiment, the case has been described in which one surgeon manipulates the endoscope device. However, as shown in FIG. 28, one end of a tube 161 may be attached to one clamp opening 12, and a treatment tool 162 for a general endoscope device may be inserted through the other end of the tube 161. With the above-described configuration, it is possible to adjust the protruding length of the treatment tool 162 from the front end of the endoscope inserting portion 3 based on the positional relationship between the other end of the tube 161 and the base end of the treatment tool 162. In addition, the manipulation operations may be shared in such a manner that the surgeon

manipulates the endoscope manipulating portion 2 and the arm manipulating portion 23 and the assistant manipulates the treatment tool 162.

In addition, in FIG. 28, the arm mechanism 20 may be attached to the clamp opening 12 instead of the clamp opening 13, and the arm portion 21 may protrude forward from the front end of the endoscope inserting portion 3 through the second lumen 9.

Here, a difference in the characteristic of the treatment tools inserted through two lumens of the endoscope device and the existence of the assistant will be described with reference to FIG. 29.

In addition, in the case of the surgical technique performed without inserting the treatment tool through the lumen of the endoscope device, in many cases, the tissue or the like is gripped or pulled by the treatment tool manipulated by the surgeon's left hand, and the tissue or the like is separated by the treatment tool manipulated by the surgeon's right hand. For this reason, even in the case of the surgical technique performed by inserting two treatment tools through the lumens of the endoscope device, generally, it is desirable that the tissue or the like gripped and pulled by the treatment tool protruding forward from the front end of the endoscope device on the left side of the surgeon and the tissue or the like is separated by the treatment tool protruding forward from the front end on the right side thereof.

As in a pattern A shown in FIG. 29, in the case where the second curves are formed in both arm mechanisms, that is, the arm mechanism protruding forward from the left side of the front end of the endoscope inserting portion and the arm mechanism protruding forward from the right side of the front end, two treatment tools may be disposed in a triangular shape as shown in FIG. 7.

As in a pattern B, in the case where the second curve is not formed in any one of the arm mechanisms, that is, the arm mechanism protruding forward from the left side of the front end of the endoscope inserting portion and the arm mechanism protruding forward from the right side of the front end, it is not possible to dispose two treatment tools in a triangular shape. However, since it is possible to shorten the rigid range where the arm portion cannot be bent, it is possible to easily approach the treatment target even in the inside of a comparatively narrow space such as a digestive canal.

As in a pattern C, in the case where the arm mechanism provided with the second curve protrudes forward from the right side of the front end of the endoscope inserting portion and a general treatment tool such as a clamp protrudes forward from the left side of the front end, it is possible to perform the treatment such as a separation operation using the arm mechanism by gripping or elevating the tissue using the treatment tool. In addition, in the case where the arm mechanism provided with the second curve is disposed in the right side of the front end of the endoscope inserting portion and a clamp raising stand is disposed so as to bend the arm mechanism, it is possible to elevate and pull the tissue by inserting the treatment tool through the arm mechanism so as to bend the treatment tool by the clamp raising stand. In the case of the pattern C, the rigid range becomes long in the arm mechanism, but the arm mechanism may be disposed in a triangular shape.

As in a pattern D, in the case where the arm mechanism without the second curve being protruded forward from the right side of the front end of the endoscope manipulating portion and the general treatment tool such as the clamp protrudes forward from the left side of the front end, and in the case where the arm mechanism without the second curve being protruded forward from the right side of the front end of

the endoscope manipulating portion and the clamp raising stand is disposed so as to bend the arm mechanism, it is possible to obtain the same advantage as that of the pattern C. Here, it is not possible to dispose the arm mechanism in a triangular shape, but it is possible to shorten the rigid range of the arm portion.

In addition, in the case of the right-handed surgeon, the combination shown in FIG. 29 is desirable. However, in the case of the left-handed surgeon, it is desirable to use the endoscope device in which the right and left in FIG. 29 are changed.

Further, a difference in the characteristic of the treatment using the treatment tool disposed in the front end of the endoscope manipulating portion and the existence of the assistant will be described with reference to FIG. 30.

As in a pattern A, in the case where the treatment tools protruding forward from both sides of the front end of the endoscope manipulating portion are the arm mechanisms, the surgeon alone performs the operations of reciprocating, opening/closing, and rotating two treatment tools inserted through the arm mechanisms. At this time, since all the manipulation operations are performed by the surgical surgeon, the surgeon alone can perform the surgical technique.

In patterns B to D, one of the treatment tools protruding forward from the front end of the endoscope manipulating portion is the arm mechanism, the other is the general clamp, and the tissue is turned over just by reciprocating the clamp. In this case, in the case where the assistant does not exist as in the pattern B, the surgeon performs the operations of reciprocating, opening/closing, and rotating the arm mechanism and the clamp. At this time, since all the manipulation operations are performed by the surgeon, the surgeon can perform the surgical technique alone.

In the case of the pattern C in which the assistant exists, the assistant performs the operations of opening/closing and rotating the clamp, and the surgeon performs the operation of reciprocating the clamp, since the manipulation is shared in the same manner as the general endoscope device, the surgeon and the assistant can have the same manipulation feeling as that of the general endoscope device. Then, in the case of the pattern D in which the assistant exists and the assistant performs the operations of reciprocating, opening/closing, and rotating the clamp, the surgeon can concentrate on the operations of manipulating the endoscope manipulating portion and one arm mechanism.

In patterns E to G, one arm mechanism protrudes forward from the front end of the endoscope manipulating portion, and the clamp raising stand is disposed so as to curve the arm mechanism. In the case where the assistant does not exist as in the pattern E, since the surgeon performs the operations of reciprocating, opening/closing, and rotating the arm mechanism and manipulating the clamp raising stand, the surgical alone can perform the surgical technique.

As in a pattern F, in the case where the assistant exists and the assistant performs the operations of opening/closing and rotating the treatment tool, since the manipulation is shared in the same manner as the general endoscope device, the surgeon and the assistant can have the same manipulation feeling as that of the general endoscope device. Then, in the case of the pattern G in which the assistant exists and the assistant performs the operations of reciprocating, opening/closing, and rotating the treatment tool, the surgeon can concentrate on the operations of manipulating the endoscope manipulating portion and the arm mechanism.

While preferred embodiments of the invention are as described and illustrated above, it should be understood that these are exemplary of the invention and are not to be con-

sidered as limiting. Additions, omissions, substitutions, and other modifications can be made without departing from the spirit or scope of the invention.

For example, in the above-described embodiments, the plane P1 where the manipulation stick 82 oscillates is perpendicular to the plane P2 where the second oscillating portion oscillates, but the planes P1 and P2 may intersect each other.

What is claimed is:

1. A manipulation mechanism comprising:

a manipulation reference plane which is perpendicular to an axis of the manipulation mechanism;

a first imaginary plane which includes the axis and which is perpendicular to the manipulation reference plane;

a second imaginary plane which includes the axis and which is perpendicular to the manipulation reference plane and the first imaginary plane;

a first oscillating portion which is configured to oscillate on the first imaginary plane;

a first guide member which is disposed on the first imaginary plane and which regulates an oscillating locus of the first oscillating portion;

a second oscillating portion which is configured to oscillate on the second imaginary plane;

a second guide member which is disposed on the second imaginary plane and which regulates an oscillating locus of the second oscillating portion; and

a manipulation stick which is fixed to the second oscillating portion and which is disposed so as to be capable of moving on the second imaginary plane,

wherein:

the first oscillating portion comprises:

a first force-transmitting-member attachment member configured so that a force transmitting member can be attached at both ends thereof;

a pair of first support members which is fixed with the first force-transmitting-member attachment member interposed there between; and

a force receiving member which is disposed in outer peripheral surfaces of base ends of the pair of first support members;

the second oscillating portion comprises:

a second force-transmitting-member attachment member configured so that a force transmitting member can be attached at both ends thereof; and

a pair of second support members which is fixed with the second force-transmitting-member attachment member interposed there between;

the first oscillating portion, the second oscillating portion and the manipulation stick are sequentially disposed on the axis;

the pair of first support members of the first oscillating portion is provided with first and second convex portions which are spaced from each other, which are disposed symmetrically to each other with respect to the axis, and which protrude in a direction orthogonal to the first imaginary plane;

the pair of second support members of the second oscillating portion is provided with first and second convex portions which are spaced from each other, which are disposed symmetrically to each other with respect to the axis, and which protrude in a direction orthogonal to the second imaginary plane;

the first guide member is provided with first and second groove portions which respectively guide, on the first

imaginary plane, the first and second convex portions of the pair of first support members of the first oscillating portion;

the second guide member is provided with first and second groove portions which respectively guide, on the second imaginary plane, the first and second convex portions of the pair of second support members of the second oscillating portion; and

in each of the first and second guide members, the first and second groove portions are formed to be closer to each other in a direction away from the manipulation reference plane on one side of the manipulation reference plane from a point on the manipulation reference plane as a start point.

2. The manipulation mechanism according to claim 1, wherein, in each of the first and second guide members, the first groove portion is formed in a circular arc shape of which a center thereof is the start point in the second groove portion, and

wherein, in each of the first and second guide members, the second groove portion is formed in a circular arc shape of which a center thereof is the start point in the first groove portion.

3. The manipulation mechanism according to claim 1, wherein the first oscillating portion and the first guide member are formed to be symmetrical to each other with respect to the first imaginary plane, and

the second oscillating portion and the second guide member are formed to be symmetrical to each other with respect to the second imaginary plane.

4. The manipulation mechanism according to claim 1, wherein the second guide member is integrally formed with the first oscillating portion the oscillating body of the other part.

5. A medical instrument comprising:

the manipulation mechanism according to claim 2;

an insertion portion which extends to the other side of the manipulation reference plane and has a base end attached to the manipulation mechanism;

a curve portion which is formed in the insertion portion so as to be bent;

a first force transmitting member which extends on the manipulation reference plane to the other side of the manipulation reference plane through the start point of the first groove portion of the first guide member and has a base end attached to the first force-transmitting-member attachment member of the first oscillating portion and a front end attached to a front end of the curve portion;

a second force transmitting member which extends on the manipulation reference toward the other side of the manipulation reference plane through the start point of the second groove portion of the first guide member and has a base end attached to the first force-transmitting-member attachment member of the first oscillating portion and a front end attached to a position different from the position where the front end of the first force transmitting member is attached to the front end of the curve portion;

a third force transmitting member which extends on the manipulation reference plane to the other side of the manipulation reference plane through the start point of the first groove portion of the second guide member and has a base end attached to the second force-transmitting-member attachment member of the second oscillating portion and a front end attached to a front end of the curve portion; and

a fourth force transmitting member which extends on the manipulation reference plane through the start point of the second groove portion of the second guide member and has a base end attached to the second force-transmitting-member attachment member of the second oscillating portion and a front end attached to a position different from the position where the front end of the third force transmitting member is attached to the front end of the curve portion.

6. The medical instrument according to claim 5, wherein tension is applied to each of the first and second force transmitting members.

7. The medical instrument according to claim 5, wherein the insertion portion is insertable through an operation channel formed in an endoscope.

8. The medical instrument according to claim 5, wherein a lumen is formed so as to allow an endoscope to be insertable there through.

9. The medical instrument according to claim 5, wherein the oscillating portion is provided with an oscillating-body-side channel, wherein the inserting portion is provided with an insertion-portion-side channel which is formed from the base end of the inserting portion to the front end thereof, and wherein the oscillating-body-side channel communicates with the insertion-portion-side channel.

10. The medical instrument according to claim 9, wherein the oscillating portion is formed to extend in a predetermined direction, and wherein the oscillating-body-side channel is formed from one end of the oscillating portion to the other end thereof.

11. The manipulation portion according to claim 10, wherein a length adjusting mechanism is disposed between the base end of the insertion portion and one end of the oscillating portion so as to adjust a distance between the insertion-portion-side channel and the oscillating-body-side channel and to communicate with the insertion-portion-side channel and the oscillating-body-side channel.

12. The medical instrument according to claim 5, wherein the insertion portion is attachable to or detachable from an operation channel of an endoscope.

13. The medical instrument according to claim 5, wherein the insertion portion is rotatable in a rotation direction about an axis thereof inside an operation channel of an endoscope.

14. The manipulation mechanism according to claim 2, wherein the first oscillating portion and the first guide member are formed to be symmetrical to each other with respect to the first imaginary plane, and the second oscillating portion and the second guide member are formed to be symmetrical to each other with respect to the second imaginary plane.

15. The manipulation mechanism according to claim 2, wherein the second guide member is integrally formed with the first oscillating portion.

16. The manipulation mechanism according to claim 1, wherein each of the first and second oscillating portions oscillates such that one of the first and second convex portions moves along the corresponding one of the first and second groove portions in a state where the other of the first and second convex portions stands at one end of the other of the first and second portions.

* * * * *

FIG. 4

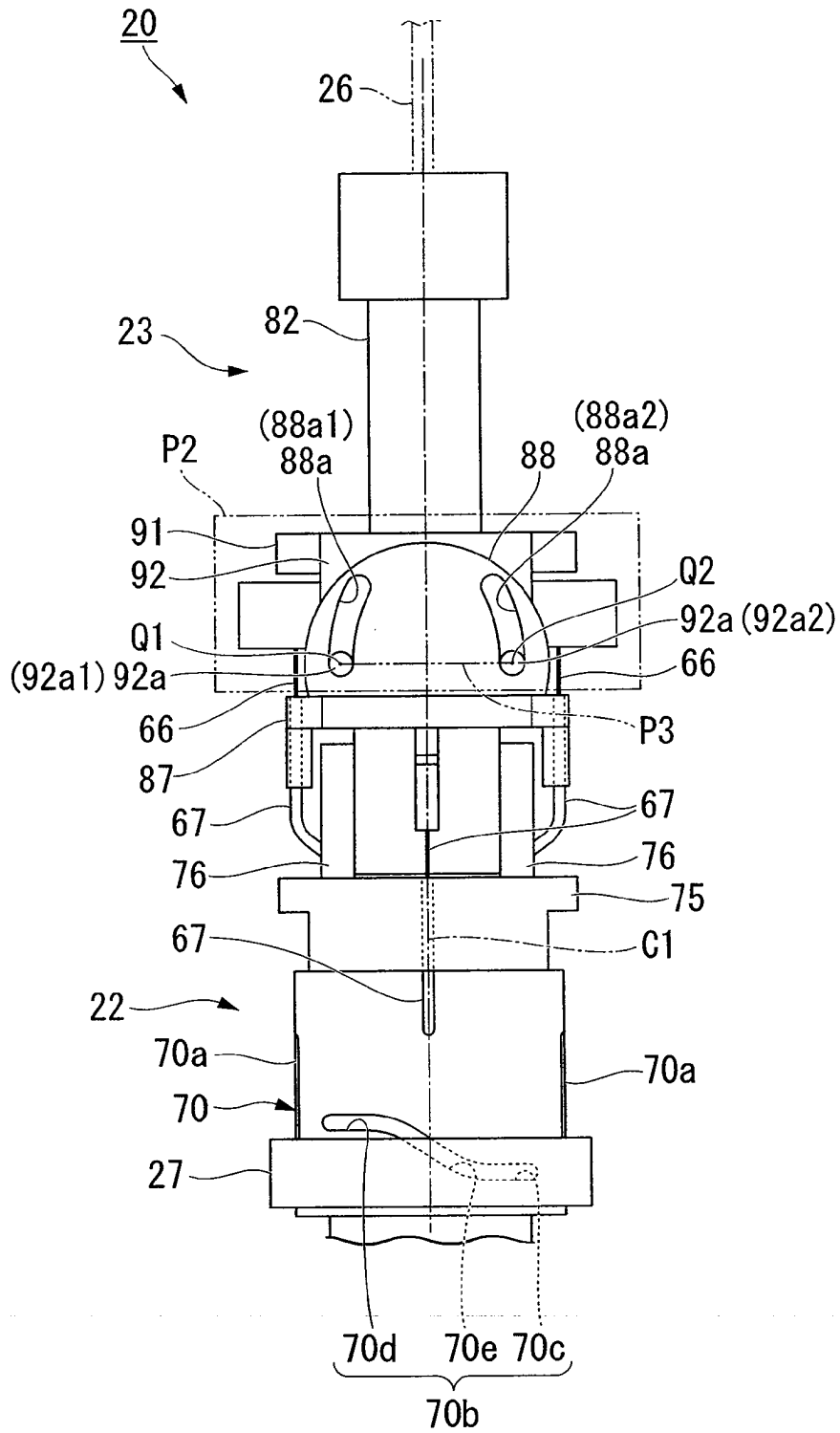

FIG. 5

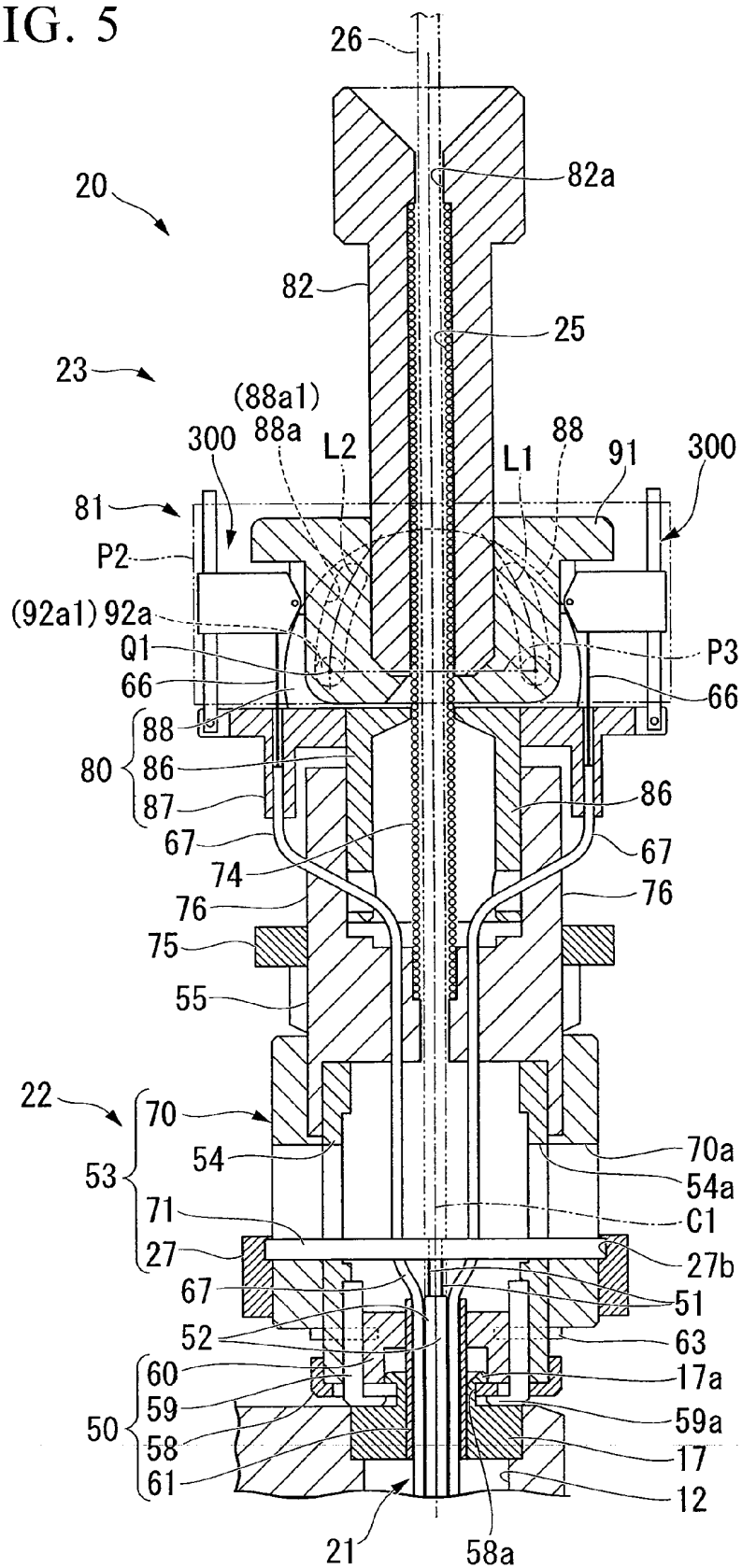

FIG. 6

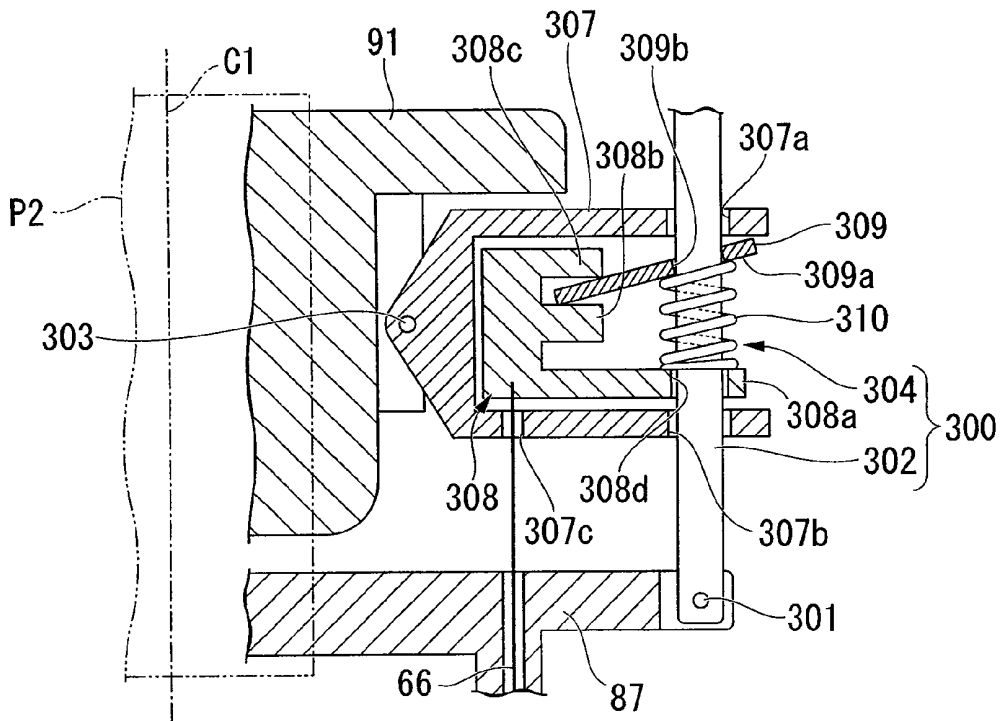

FIG. 7

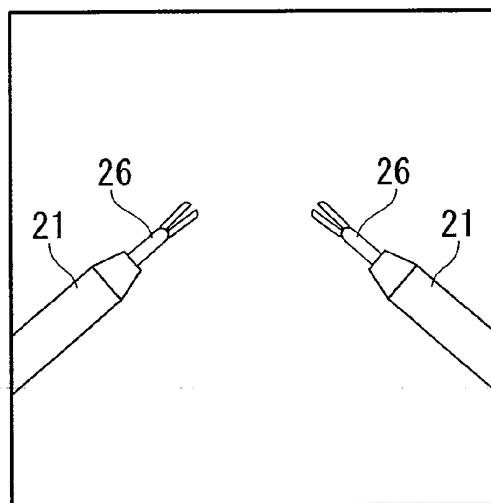

FIG. 8

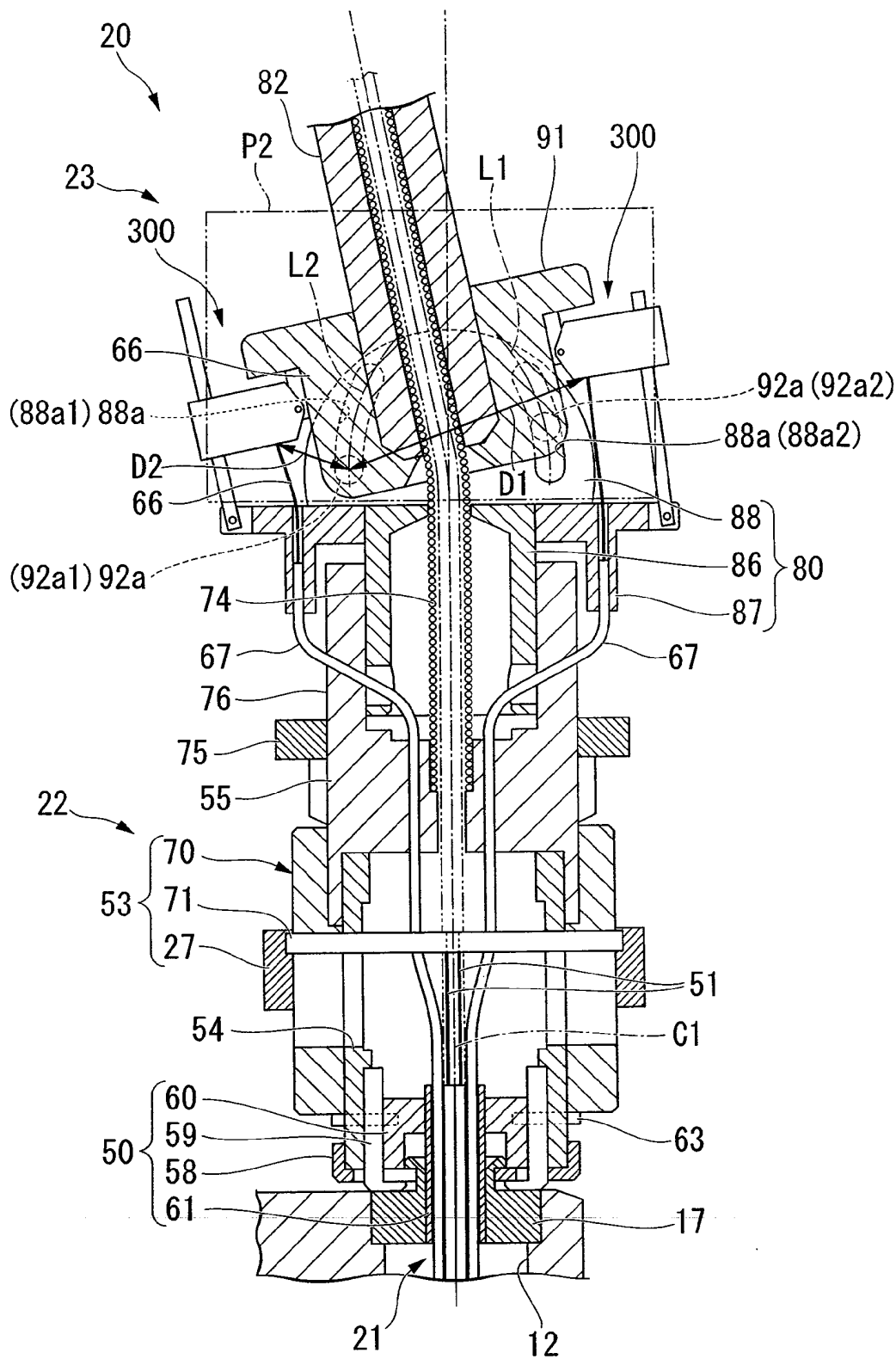

FIG. 9

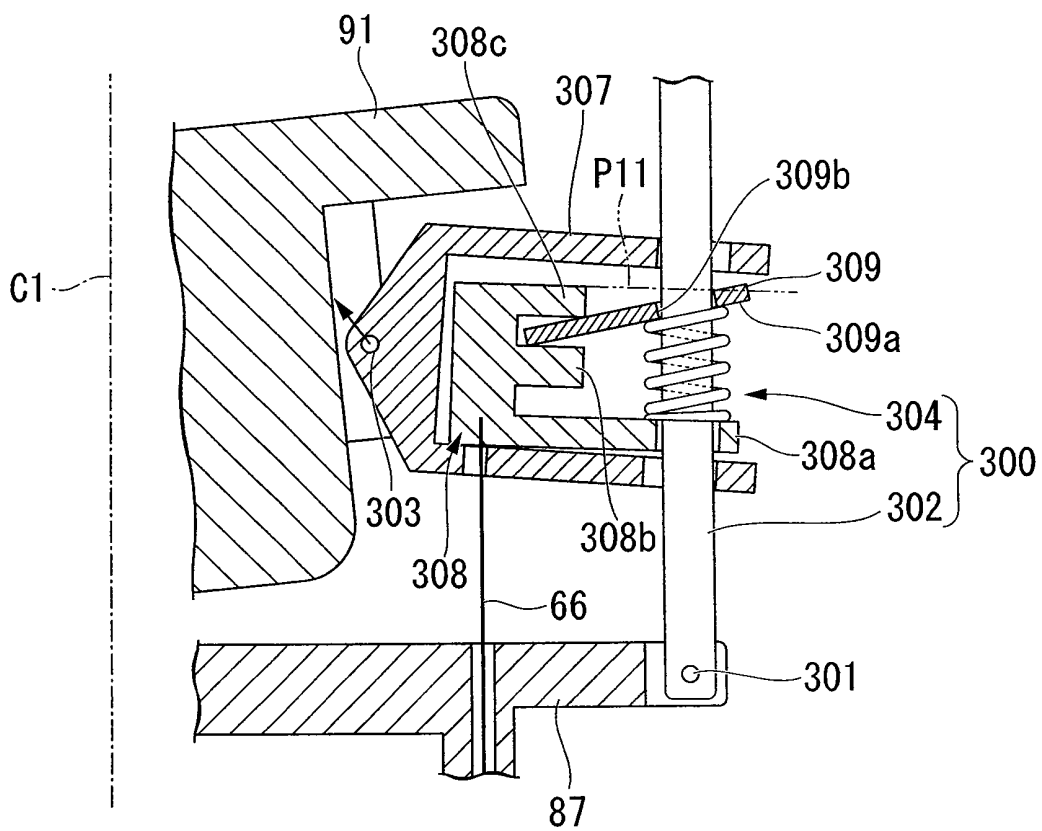
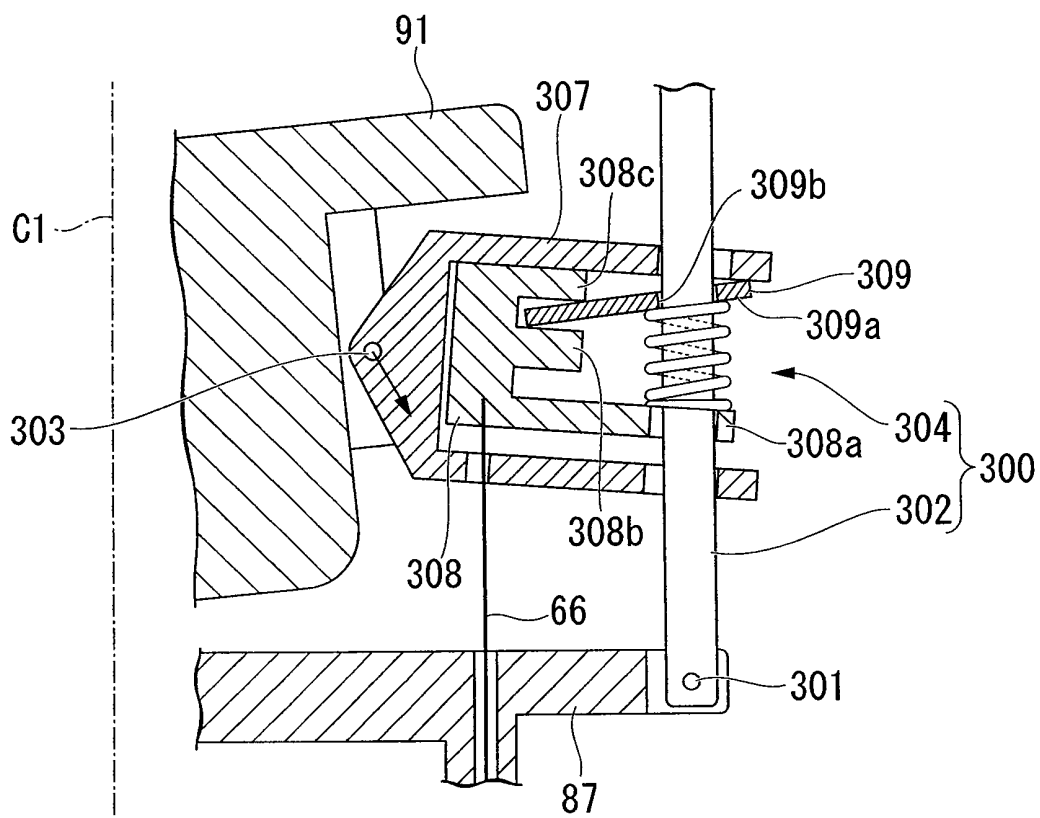

FIG. 10



专利名称(译)	操纵机构和医疗器械仪器		
公开(公告)号	US8460276	公开(公告)日	2013-06-11
申请号	US12/551618	申请日	2009-09-01
[标]申请(专利权)人(译)	出岛TAKUMI		
申请(专利权)人(译)	桥本TATSUTOSHI 出岛, TAKUMI		
当前申请(专利权)人(译)	奥林巴斯医疗系统股份有限公司.		
[标]发明人	HASHIMOTO TATSUTOSHI DEJIMA TAKUMI		
发明人	HASHIMOTO, TATSUTOSHI DEJIMA, TAKUMI		
IPC分类号	A61B17/00		
CPC分类号	A61B17/29 A61B17/2909 A61B19/22 A61B1/018 A61B2017/003 A61B2019/2276 A61B2017/2906 A61B2017/291 A61B2017/2927 A61B2019/2211 A61B2019/2242 A61B2017/0034 A61B1/00098 A61B1/ /00133 A61B34/70 A61B34/71 A61B2034/301 A61B2034/742		
代理机构(译)	OSTROLENK FABER LLP		
优先权	61/093492 2008-09-02 US		
其他公开文献	US20100063354A1		
外部链接	Espacenet USPTO		

摘要(译)

一种用于在软内窥镜中在稳定轨迹中移动振动体的操纵机构，例如用于腹腔镜手术。该机构具有在第一和第二假想平面上振动的第一和第二振动部分以及调节第一和第二振动部分的振动轨迹的导向构件。操纵杆固定到第二振动部分并且能够在第二假想平面上移动。振动部分别具有传力部件安装部件，一对第一支撑部件和受力部件。一对第一支撑构件设置有第一凸部和第二凸部，并且第一引导构件和第二引导构件中的每一个设置有第一槽部和第二槽部，第一槽部和第二槽部形成为在远离操作基准面的方向上彼此靠近。

