



US007686822B2

(12) **United States Patent**  
**Shayani**

(10) **Patent No.:** **US 7,686,822 B2**  
(45) **Date of Patent:** **Mar. 30, 2010**

(54) **HERNIA REPAIR METHOD**

(56) **References Cited**

(76) Inventor: **Vafa Shayani**, 110 North Quincy St.,  
Hinsdale, IL (US) 60521  
(\* ) Notice: Subject to any disclaimer, the term of this  
patent is extended or adjusted under 35  
U.S.C. 154(b) by 484 days.

U.S. PATENT DOCUMENTS  
5,282,616 A 2/1994 Stacavich-Notaro  
5,384,939 A 1/1995 Weber  
5,697,979 A \* 12/1997 Pignataro ..... 623/15.11  
D390,099 S 2/1998 Bailey et al.  
5,728,116 A 3/1998 Rosenman  
5,972,022 A 10/1999 Huxel  
6,036,701 A 3/2000 Rosenman  
6,735,819 B2 5/2004 Iverson et al.

(21) Appl. No.: **11/753,303**

\* cited by examiner

(22) Filed: **May 24, 2007**

*Primary Examiner*—(Jackie) Tan-Uyen T Ho  
*Assistant Examiner*—Christina Lauer  
(74) *Attorney, Agent, or Firm*—Boyle Fredrickson, SC

(65) **Prior Publication Data**

US 2007/0219569 A1 Sep. 20, 2007

**Related U.S. Application Data**

(57) **ABSTRACT**

(62) Division of application No. 10/436,812, filed on May  
13, 2003, now abandoned.

An article of manufacture suitable for positioning a sheet of  
mesh material over tissue is described. In one embodiment,  
the article comprises a surgical tack having a hook-type mate-  
rial such as Velcro® material carried by the tack, e.g., secured  
to the top of the head thereof. A plurality of such tacks are  
positioned around the site of a hernia or the like and the mesh  
is positioned over the site and the tacks. The mesh is made of  
a loop-type Velcro® material or the like which allows the  
mesh to be releasably engaged and disengaged from the hook-  
type material carried by the tacks so that the mesh can be  
appropriately positioned over the tissue.

(51) **Int. Cl.**  
**A61B 17/08** (2006.01)

(52) **U.S. Cl.** ..... **606/151**; 606/156

(58) **Field of Classification Search** ..... 623/23.72,  
623/17.19, 23.54; 606/70, 285, 151-156;  
128/898

See application file for complete search history.

**17 Claims, 3 Drawing Sheets**

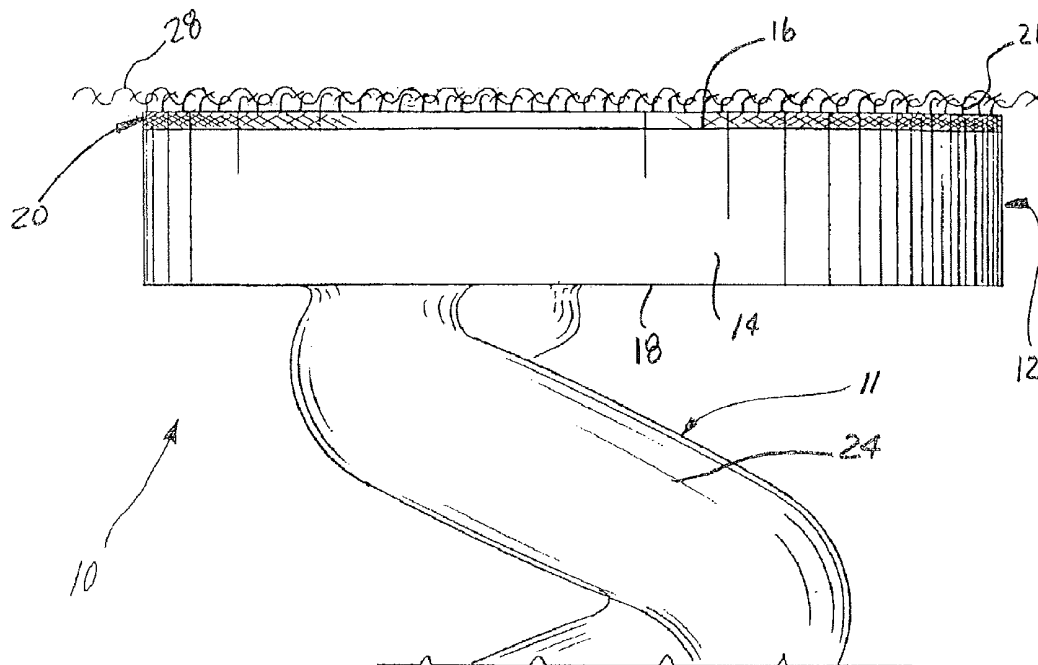

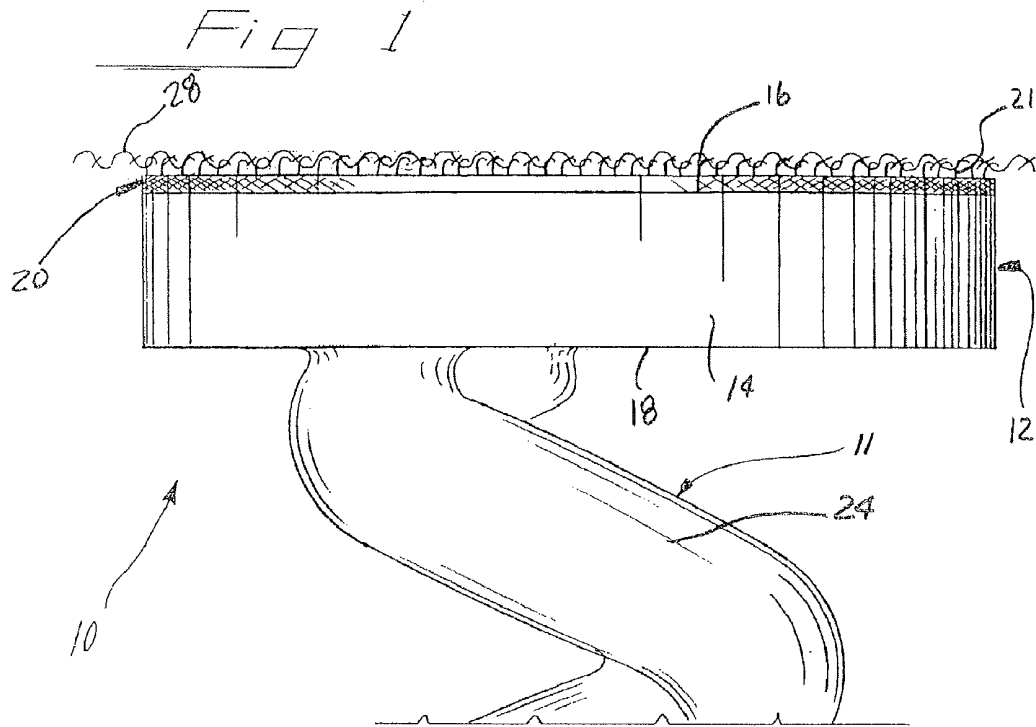
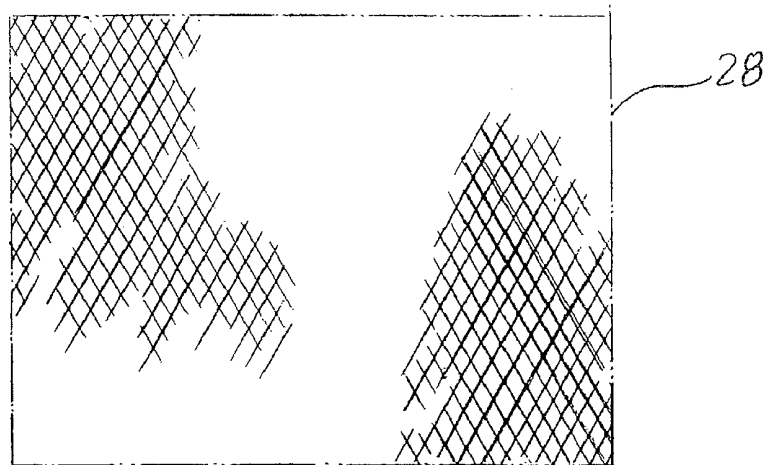

Fig 2



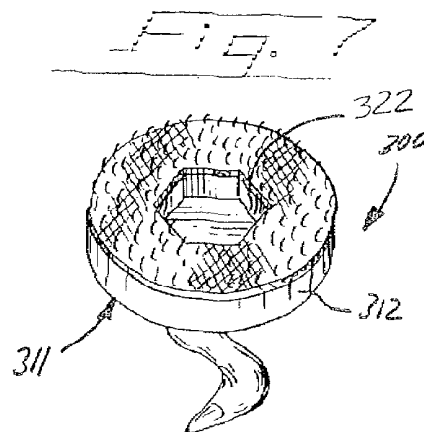
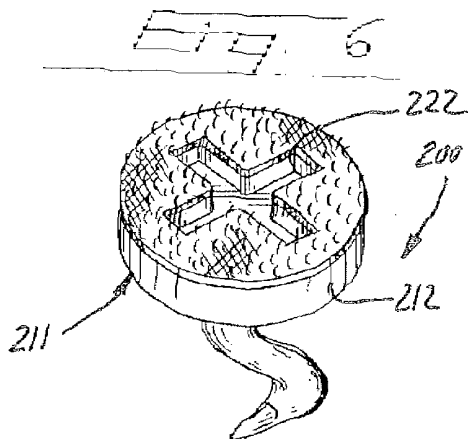
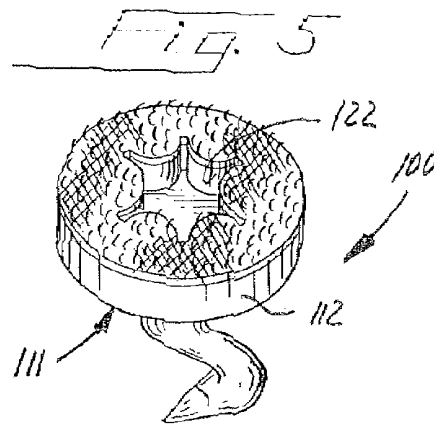
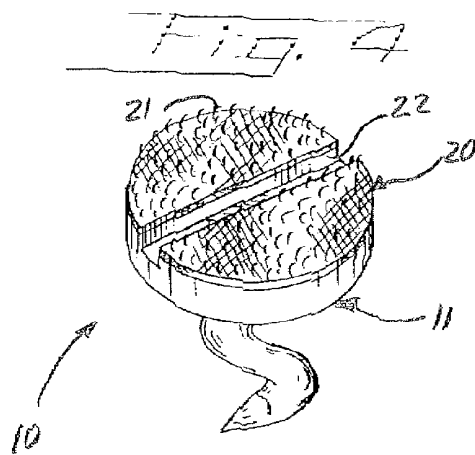
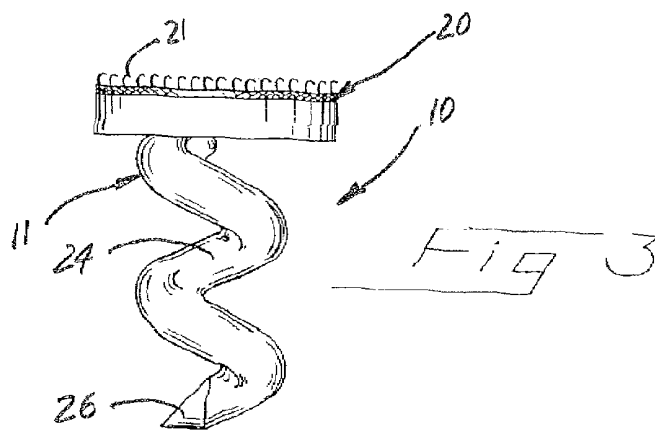
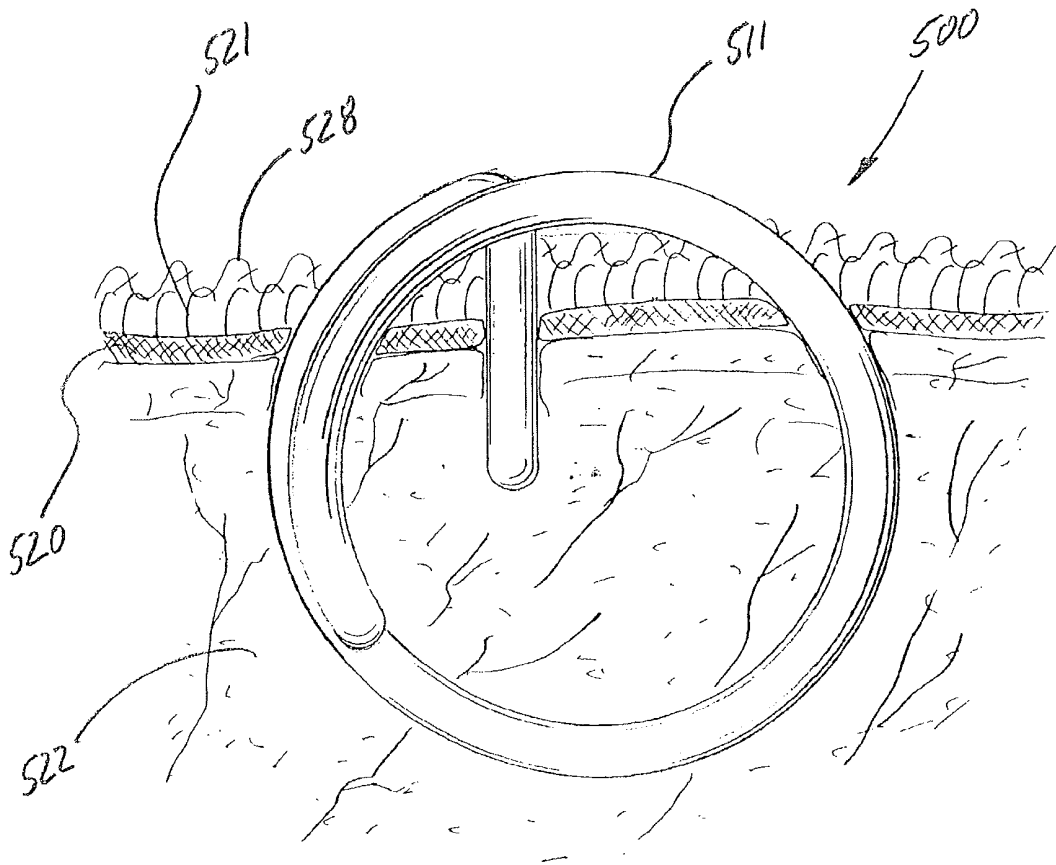

Fig. 8



**HERNIA REPAIR METHOD****CROSS-REFERENCE TO RELATED APPLICATIONS**

This application is a divisional application and claims priority to U.S. application Ser. No. 10/436,812, filed on May 13, 2003 now abandoned, titled "Article for positioning mesh over tissue", which was published on Nov. 18, 2004 as U.S. Patent Application Publication No. 2004/0230208 and the disclosure of which is incorporated herein.

**FIELD OF THE INVENTION**

This invention relates to surgical devices and, more particularly, to surgical articles used to position and fix mesh over tissue for repair of abdominal wall defects.

**BACKGROUND OF THE INVENTION**

Abdominal wall defects or hernias are commonly repaired using a physiologically compatible synthetic mesh such as a polytetrafluoroethylene mesh, polypropylene mesh, and the like. Tension-free mesh repair of hernias is preferred over conventional suture closure, which often results in the creation of significant tension and subsequent recurrence of the hernia. More recently, video-assisted (laparoscopic) technology has been utilized to repair the abdominal wall defects from a posterior (from inside the abdomen) position, thus offering the potential for a lower incidence of subsequent recurrence of the hernia. Where the laparoscopic technique is utilized, the synthetic mesh is typically secured against the abdominal wall using surgical tacks of various types, for example of the type disclosed in U.S. Pat. Nos. 5,728,116 and 6,036,701, and also of the Q-ring type commercially available from Onux Medical, Inc. of Hampton, N.H.

One of the challenges encountered during laparoscopic hernia repair is the placement of the mesh and the tacks in the precisely intended location to provide adequate overlap of the mesh with the surrounding abdominal wall tissue. With each application of an additional surgical tack, repositioning of the mesh (when necessary) becomes more and more difficult, if not impossible. In addition, during the early process of tacking the mesh to the abdominal wall, the field of view is often significantly hindered by the partially dangling piece of mesh. This limitation may reach unsafe levels in cases of large abdominal wall defects requiring large pieces of mesh, with significant potential for inadvertent injury to abdominal organs.

There is, therefore, a need for improving the existing technique of laparoscopic hernia repair through the use of a tack or the like that would allow placement of the tacks before obliteration of the view by the mesh, and subsequent near-perfect positioning and repositioning of the mesh as needed.

**SUMMARY OF THE INVENTION**

The present invention provides a safe and efficient means or article for the application and subsequent repositioning of synthetic mesh to the abdominal wall with minimal risk of injury to abdominal tissue and organs.

Accordingly, the invention is an article suitable for positioning a sheet of surgical mesh over tissue and comprising a mesh engaging material associated with a tack adapted to be fastened to the tissue. The mesh is releasably engaged and disengaged from the mesh engaging material associated with

the tack so as to allow the positioning and subsequent repositioning and stretching of the mesh over the tissue.

In one embodiment, the tack includes a head bearing a hook-type fiber material and a tissue anchoring member which depends from the head. The tack is secured to the tissue and the mesh material is releasably engageable with the hook-type material carried by the tack. In this manner the mesh material can be positioned and repositioned over tissue as desired by the surgeon.

In another embodiment, the tack secures a piece of the mesh engaging material to the tissue. The mesh can then be pressed against the mesh engaging material secured to the tissue and is releasably held in place by the mesh engaging material.

Other advantages and features of the present invention will be more readily apparent from the following detailed description of the preferred embodiments of the invention, the accompanying drawings, and the appended claims.

**BRIEF DESCRIPTION OF THE DRAWINGS**

In the accompanying drawings forming part of the specification and in which like numerals are employed to designate like parts throughout the same,

FIG. 1 is an enlarged, partial front elevational view of a surgical tack provided with releasable mesh engagement element;

FIG. 2 is a top plan view of a patch of surgical mesh suitable for releasable engagement to the mesh engagement element shown in FIG. 1;

FIG. 3 is a front elevational view of the entire surgical tack of FIG. 1;

FIG. 4 is a perspective view of the surgical tack of FIG. 3 provided with a slotted head;

FIG. 5 is a perspective view of a tack similar to that of FIG. 3 and provided with a head configured to receive a Torx driver;

FIG. 6 is a perspective view of a tack similar to that of FIG. 3 and configured to receive a Phillips driver;

FIG. 7 is a perspective view of a tack similar to that of FIG. 3 and configured to receive an Allen driver; and

FIG. 8 is an enlarged, fragmentary front elevational view depicting the releasable mesh engagement element held in place with a Q-ring type of tack.

**DETAILED DESCRIPTION OF THE PREFERRED EMBODIMENTS**

The invention disclosed herein is susceptible of embodiment in many different forms. Shown in the drawings and described hereinbelow in detail are preferred embodiments of the invention. It is to be understood, however, that the present disclosure is an exemplification of the principles of the invention and does not limit the invention to the illustrated embodiments.

Moreover, it is understood that the specification herein does not necessarily describe the details of the surgical tack or the releasable mesh engagement element that are known in the art and that will be recognized as such by those skilled in the art. The detailed descriptions of these elements are not necessary to an understanding of the article of the present invention. Accordingly, such elements are herein represented and described only to the degree necessary to aid in an understanding of the features of the present invention.

FIGS. 1, 3 and 4 depict a preferred embodiment of the present invention in which article 10 comprises a surgical tack

**11** having a releasable mesh engagement element or member **20** attached to the top of head **12**.

Head **12** has a circular, disk like figuration and includes a body **14** and top and bottom radial faces **16** and **18**, respectively. The top face **16** of the head **12** is covered with a circular, disk shaped releasable mesh engagement member, such as patch **20**, which is preferably made of and includes hook-type Velcro® or the like latching fiber material **21**. The mesh engagement member such as patch **20** may be secured to the top face **16** of the head **12** by any known means including, but not limited to, adhesive applied either directly to the top of the head **12**, to the lower surface of the mesh engagement member **20**, or both. A tack driver cavity, such as slot or straight slit **22**, extends across top face **16** and into the body **14** of head **12**. The slot **22** is configured to receive a complementary driver.

The tack **11** additionally comprises an elongate spiral screw member or base **24** which extends generally away from the bottom radial face **18** of the head **12**. The spiral screw member **24** terminates in a distal tissue piercing tip **26**.

FIGS. 5-7 depict alternate respective article embodiments **100**, **200** and **300** similar in structure to the article **10** except that the respective heads **112**, **212** and **312** of the tacks **111**, **211** and **311** respectively incorporate cavities **122**, **222** and **322** structured and shaped to accept Torx, Phillips or Allen drivers for driving and securing the tacks into tissue for the purposes described in more detail below.

The article **10** of the present invention is suitable for use in a variety of surgical procedures including, but not limited to, the repair of ventral hernias. In connection with the repair of ventral hernias, an incision is first made into a patient's abdominal cavity in order to access the site of the hernia (i.e., abdominal wall defect) using conventional surgical techniques. After the site has been prepared using conventional surgical techniques, several tacks capable of releasably holding a surgical mesh are secured around the perimeter of the abdominal wall defect using conventional tacking devices such as, for example, a surgical grasper, a tack driver, or alternatively, a tacking gun which has been pre-loaded with a predetermined number of the surgical tacks.

The tacks **11** are advantageously secured to the tissue around the abdominal wall defect sought to be repaired prior to the insertion of any mesh material into the abdominal cavity, and with the full view of the abdominal wall defect and surrounding internal organs. Thereafter, an appropriately sized sheet or patch of the biocompatible surgical mesh, for example, such as the sheet of mesh material **28** depicted in FIG. 2, is inserted through the incision and positioned over the site of the hernia with the peripheral edges thereof overlying the tacks. The mesh material is then pressed into abutting contact against the tacks **11** and, more specifically, against the heads **12** thereof so as to cause the loop-type material comprising the fabric of the mesh **28** to become releasably intertwined, latched and engaged with the hook-type material **21** of tack **11** as shown in FIG. 1. The mesh **28** may then be selectively disengaged or released from tack **11**, and then subsequently selectively stretched and re-attached or re-engaged with the latching fiber material until the optimal positioning and stretching of the mesh **28** over the tissue site has been achieved.

Once the desired mesh placement has been accomplished, any one of a number of conventional tacking devices may be used to apply conventional surgical tacks to further secure and maintain the mesh **28** over the site of the hernia. The hernia repair procedure is then completed in a conventional manner and the incision in the wall of the abdominal cavity is closed using conventional surgical sutures.

The foregoing description is to be taken as illustrative, but not limiting of the scope of the present invention. Still other variants within the spirit and scope of the present invention will readily present themselves to those skilled in the art such as, for example, the alternate article **500** shown in FIG. 8 where a patch or strip **520** including Velcro® type hook material **521** is positioned against the tissue **522** and a Q-ring type tack **511** of the type manufactured by Onux Medical, Inc. of Hampton, N.H. is driven through the patch **520** and into the tissue **522** to fasten the patch **520** to the tissue. It is understood, of course, that a plurality of patches such as patch **520** are positioned around the hernia site, and that a plurality of the tacks **511** are driven through the patches **520** respectively. The mesh **528** is then releasably securable to the aforesaid plurality of patches in the same manner as that described above with respect to the tacks **11**.

What I claim is:

1. A method of positioning and securing a sheet of mesh material over tissue comprising:

- (a) securing a plurality of tacks to the tissue, each of the tacks having a mesh engagement element associated therewith;
- (b) positioning the sheet of mesh material over the tissue and the tacks;
- (c) pressing the sheet of mesh material against the tacks and the mesh engagement elements thereon; and
- (d) adjusting the position of sheet of mesh material over the tissue by releasably engaging and disengaging the sheet of mesh material from the mesh engagement elements.

2. The method of claim 1 wherein securing the plurality of tacks to the tissue includes positioning a plurality of the mesh engagement elements to the tissue and then driving a plurality of the tacks through the mesh engagement elements and into the tissue.

3. The method of claim 1 further comprising fastening the sheet of mesh material to the tissue following adjusting the position of sheet of mesh material over the tissue by releasably engaging and disengaging the sheet of mesh material from the mesh engagement elements.

4. A method of relieving tension of a damaged tissue comprising:

- (a) engaging a number of physiologically compatible tacks with physiology proximate the damaged tissue;
- (b) engaging a mesh with a head of each tack positioned on one side of the damaged tissue;
- (c) tensioning the mesh across the damaged tissue and engaging the mesh with a head of a tack positioned on another side of the damaged tissue; and
- (d) adjusting the tension of the mesh by repositioning the mesh relative to one of the tacks such that the mesh transfers a load away from the damaged tissue to the number of tacks.

5. The method of claim 4 wherein the physiology proximate the damaged tissue is muscle tissue.

6. The method of claim 4 further comprising passing a number of tacks through the mesh after the tension of the mesh has been adjusted such that the mesh is positioned between a number of tacks.

7. The method of claim 4 wherein engaging the number of tacks with physiology includes rotating each tack relative to the physiology.

8. The method of claim 4 further comprising adjusting the tension of the mesh by repositioning the mesh relative to a number of tacks such that the tension of the mesh can be adjusting in a first direction and a crossing direction.

5

9. A method of repairing a rupture comprising:  
 engaging a number of tacks with tissue proximate the rupture;  
 placing a mesh proximate the number of tacks;  
 engaging the mesh with a first tack;  
 tensioning the mesh toward a second tack;  
 engaging the mesh with the second tack to maintain the tension of the mesh; and  
 wherein the mesh is repositionable with respect to the tacks by pulling the mesh in a direction generally opposite the tension and without moving the tacks relative to the tissue.

10. The method of claim 9 wherein the mesh removably engages a side of the tacks generally opposite the tissue.

11. The method of claim 9 further comprising closing an opening in a patient that is formed to allow passage of the tacks and the mesh therethrough and sized to allow laparoscopic repair of the rupture.

12. The method of claim 11 further comprising passing the tacks through the opening and engaging the tacks with the tissue prior to positioning the mesh generally across the rupture.

6

13. The method of claim 9 further comprising passing a number of openings formed in the mesh over a number of hooks formed on a surface of each tack that is generally opposite a surface of the tack facing the tissue.

14. The method of claim 9 further comprising passing a barb of a supplemental tack through the mesh and into engagement with the tissue after the mesh has been secured by the first and second tacks.

15. The method of claim 9 wherein engaging the tacks with the tissue includes rotating the tacks about an axis that is generally perpendicular to the tissue.

16. The method of claim 15 further comprising engaging a tool with a tack driver cavity formed in a portion of the tack so that rotating a portion of the tool rotates the tack.

17. The method of claim 9 further comprising removing the mesh and the tacks upon repair of the tissue that resulted in the rupture.

\* \* \* \* \*

|                |                                     |                       |            |
|----------------|-------------------------------------|-----------------------|------------|
| 专利名称(译)        | 疝气修复方法                              |                       |            |
| 公开(公告)号        | <a href="#">US7686822</a>           | 公开(公告)日               | 2010-03-30 |
| 申请号            | US11/753303                         | 申请日                   | 2007-05-24 |
| [标]申请(专利权)人(译) | SHAYANI VAFA                        |                       |            |
| 申请(专利权)人(译)    | SHAYANI VAFA                        |                       |            |
| 当前申请(专利权)人(译)  | SHAYANI VAFA                        |                       |            |
| [标]发明人         | SHAYANI VAFA                        |                       |            |
| 发明人            | SHAYANI, VAFA                       |                       |            |
| IPC分类号         | A61B17/08 A61B17/064 A61F2/00       |                       |            |
| CPC分类号         | A61B17/064 A61B2017/0649 A61F2/0063 |                       |            |
| 其他公开文献         | US20070219569A1                     |                       |            |
| 外部链接           | <a href="#">Espacenet</a>           | <a href="#">USPTO</a> |            |

摘要(译)

描述了一种适于将网片材料片定位在组织上的制品。在一个实施方案中，所述制品包括具有钩型材料的外科手术钉，所述钩型材料例如由所述钉子承载的Velcro材料，例如固定到其头部的顶部。多个这样的钉子定位在疝等的部位周围，并且网状物定位在部位和钉子上方。网状物由环状Velcro材料等制成，其允许网状物可释放地与由钉子承载的钩型材料接合和脱离，使得网状物可以适当地定位在组织上。

