



US007187784B2

(12) **United States Patent**
Tawfiq et al.

(10) **Patent No.:** **US 7,187,784 B2**
(45) **Date of Patent:** **Mar. 6, 2007**

(54) **BORESCOPE FOR DRILLED SHAFT INSPECTION**

(75) Inventors: **Kamal Tawfiq**, Tallahassee, FL (US);
Edward J. Mallory, Tallahassee, FL (US);
Sastry Putcha, Tallahassee, FL (US);
Dan Turner, Lake City, FL (US)

(73) Assignee: **Florida State University Research Foundation, Inc.**, Tallahassee, FL (US)

(*) Notice: Subject to any disclaimer, the term of this patent is extended or adjusted under 35 U.S.C. 154(b) by 421 days.

(21) Appl. No.: **10/776,817**

(22) Filed: **Feb. 11, 2004**

(65) **Prior Publication Data**

US 2004/0160514 A1 Aug. 19, 2004

Related U.S. Application Data

(63) Continuation-in-part of application No. 09/409,450, filed on Sep. 30, 1999, now abandoned.

(60) Provisional application No. 60/102,408, filed on Sep. 30, 1998.

(51) **Int. Cl.**

G06K 9/00 (2006.01)
G01V 1/40 (2006.01)
G01V 3/18 (2006.01)
E21B 47/00 (2006.01)
A61B 1/04 (2006.01)

(52) **U.S. Cl.** **382/109; 702/6; 73/152.02; 166/250.01; 175/50; 348/85**

(58) **Field of Classification Search** None
See application file for complete search history.

(56) **References Cited**

U.S. PATENT DOCUMENTS

4,079,625 A 3/1978 Mann

4,938,060 A	7/1990	Sizer et al.	
5,123,492 A	6/1992	Lizanic, Jr.	
5,255,245 A	10/1993	Clot	
5,355,128 A	10/1994	Riordan	
5,379,216 A *	1/1995	Head	702/12
5,485,745 A	1/1996	Rademaker et al.	
5,550,331 A	8/1996	Thompson	
5,587,525 A *	12/1996	Shwe et al.	73/152.52
5,663,559 A	9/1997	Auzerais et al.	
5,754,220 A	5/1998	Smalser, Sr.	
5,996,711 A *	12/1999	Ohmer	175/61
6,041,860 A	3/2000	Nazzal et al.	
6,157,893 A *	12/2000	Berger et al.	702/9
6,164,126 A *	12/2000	Ciglenec et al.	73/152.01
6,281,489 B1 *	8/2001	Tubel et al.	250/227.14
6,307,199 B1 *	10/2001	Edwards et al.	250/269.3

* cited by examiner

Primary Examiner—Jingge Wu

Assistant Examiner—Charles Kim

(74) *Attorney, Agent, or Firm*—Senniger Powers

(57) **ABSTRACT**

Visual inspection of an interior surface of a borehole. A housing adapted to be lowered in the borehole supports a portable camera for generating images of a portion of the interior surface of the borehole and a light source for illuminating an area adjacent the camera. A monitor receives signals from the camera and, in response thereto, displays the images generated by the camera. A viewing envelope positioned adjacent the camera defines a viewing area adjacent the camera, particularly for use in visually inspecting slurry-filled boreholes.

31 Claims, 9 Drawing Sheets

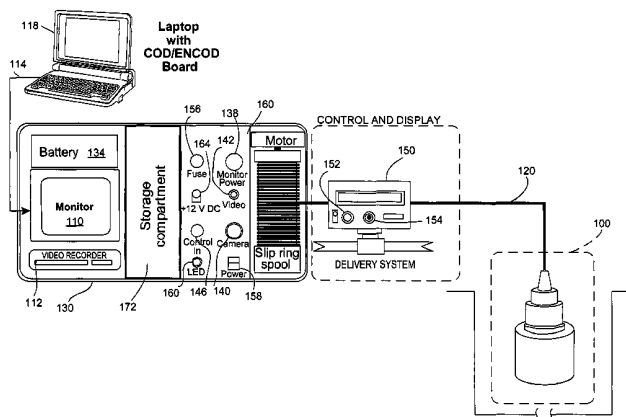

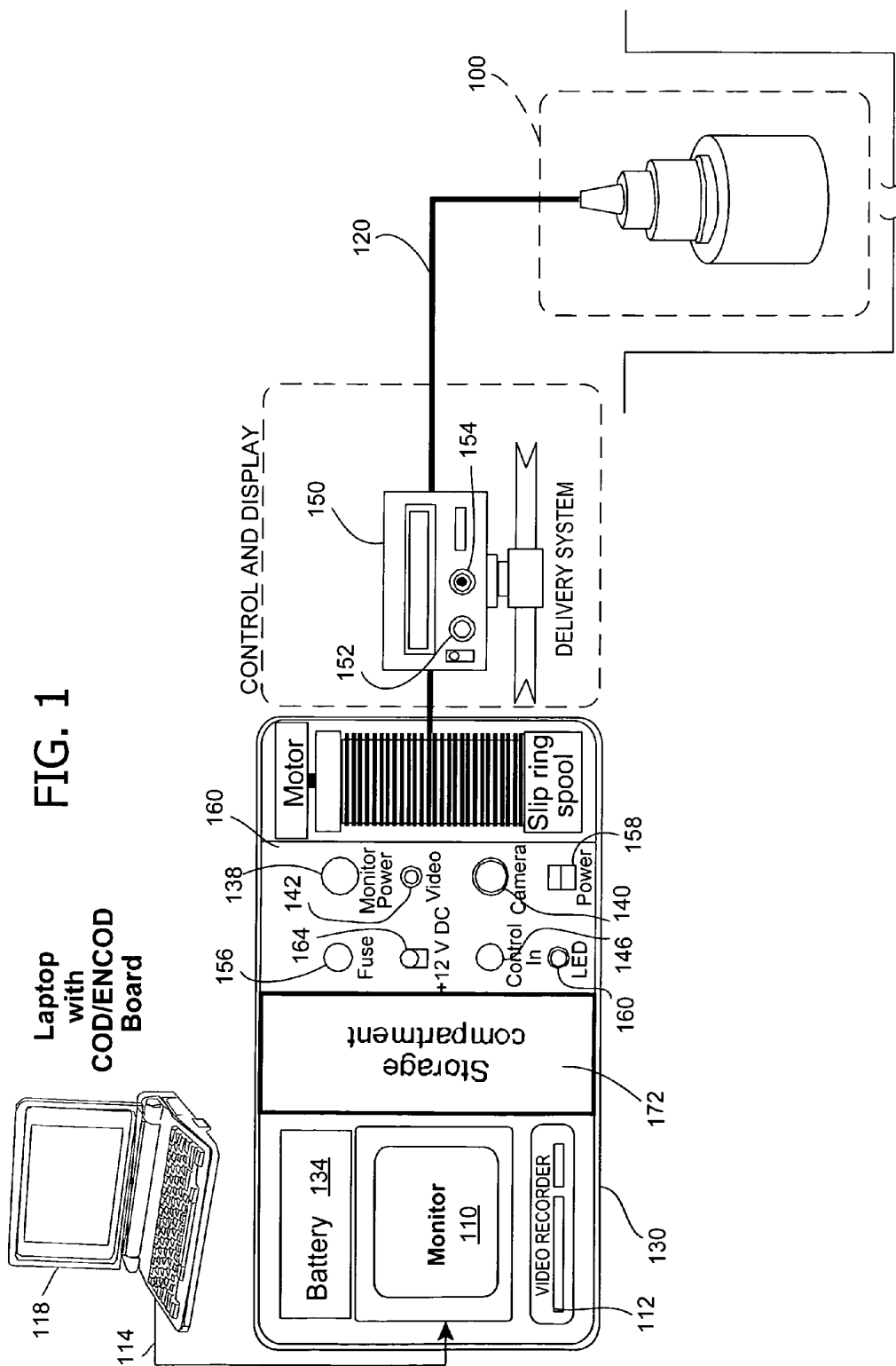

FIG. 1

FIG. 2

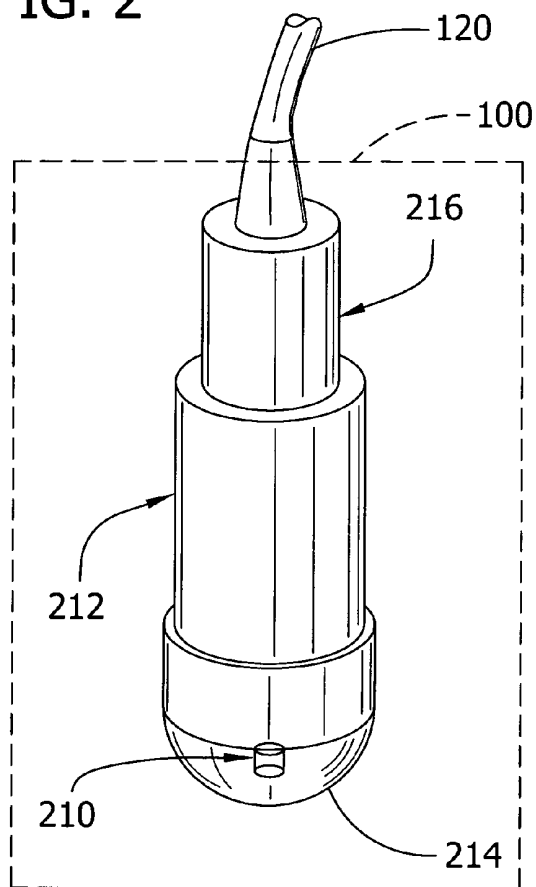

FIG. 3

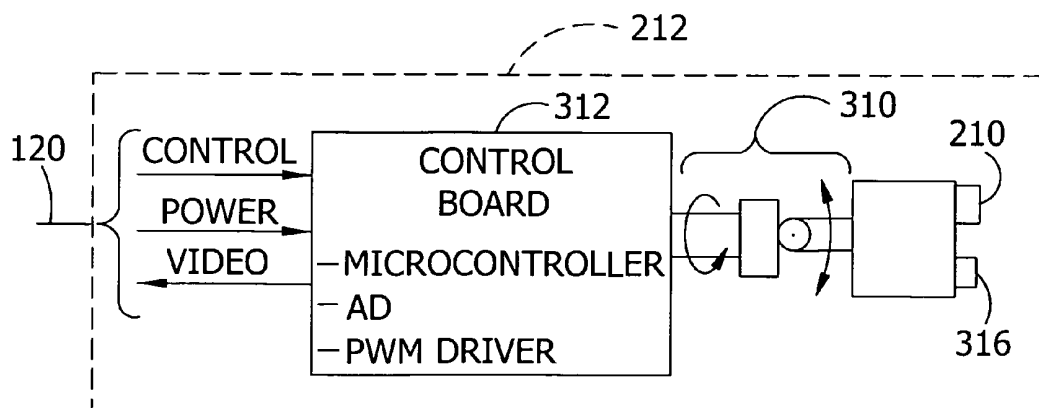

FIG. 4

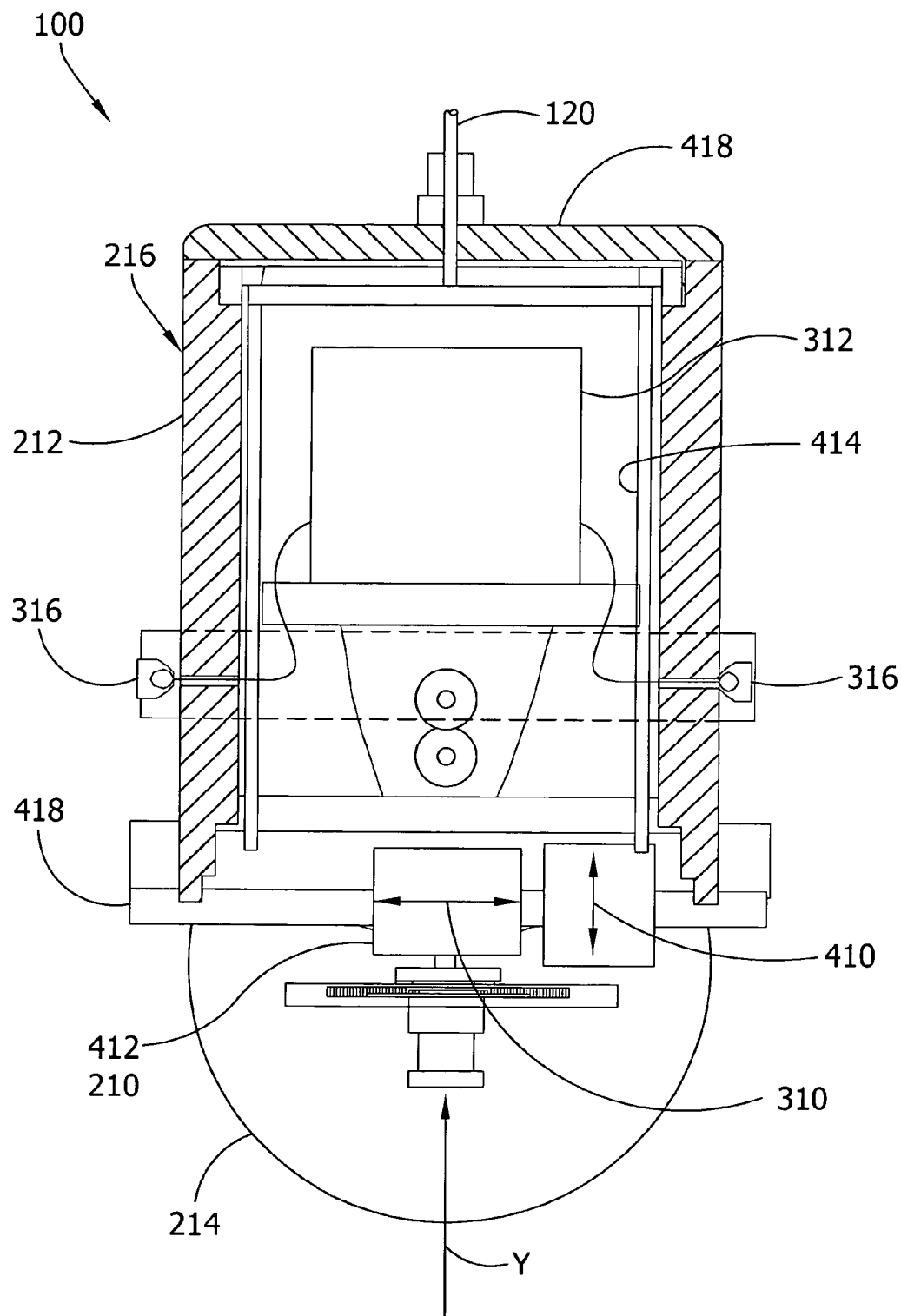

FIG. 5

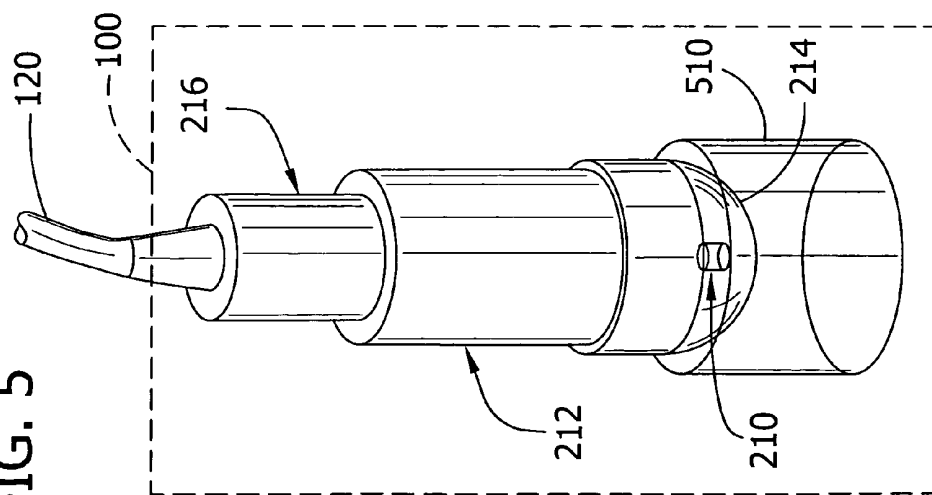
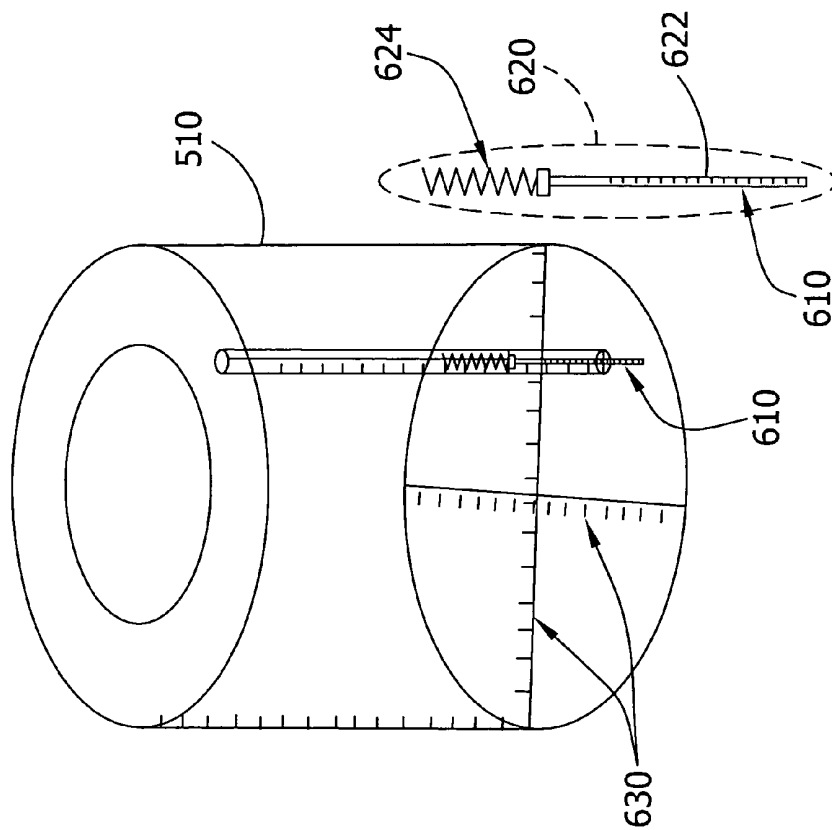

FIG. 6



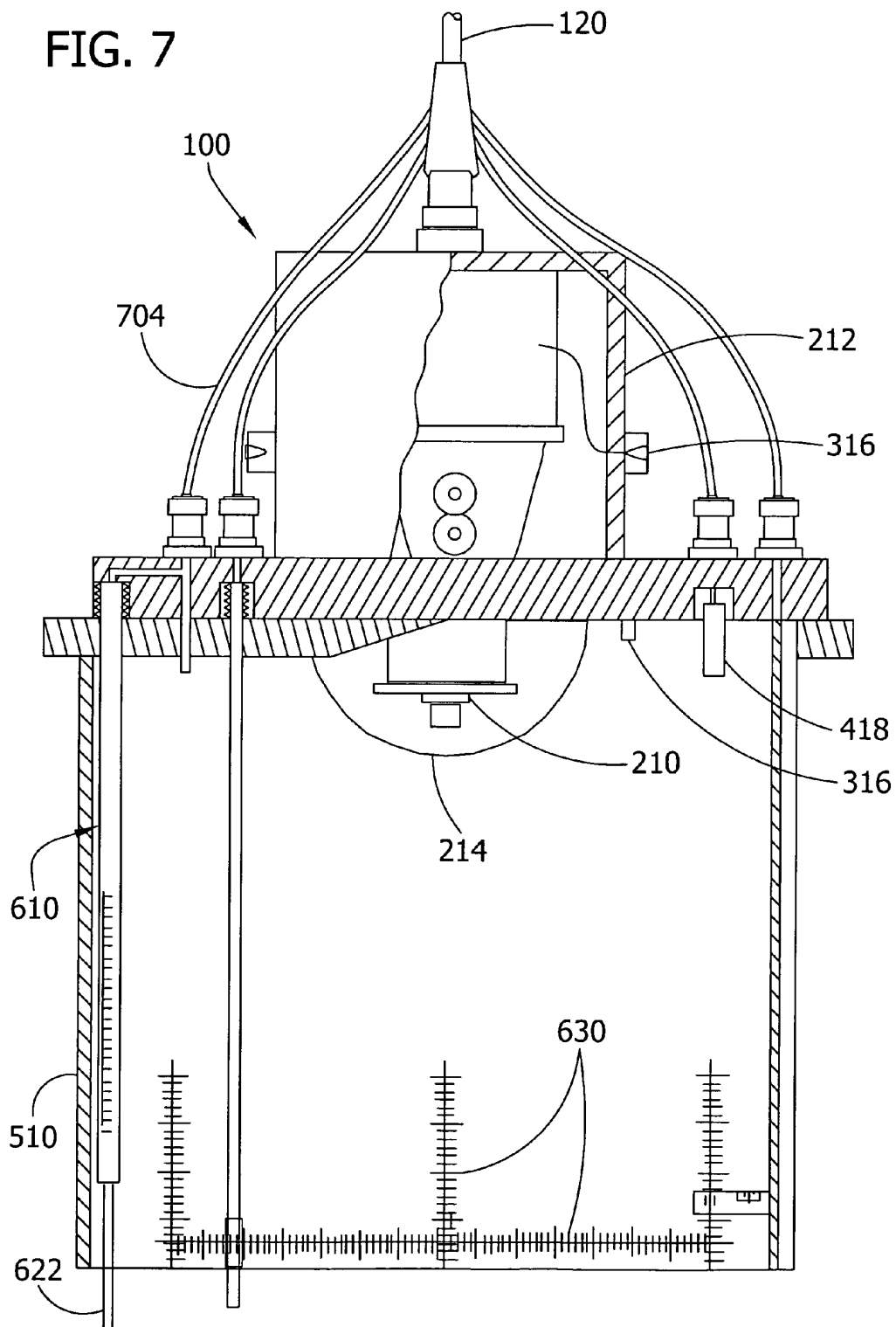

FIG. 8

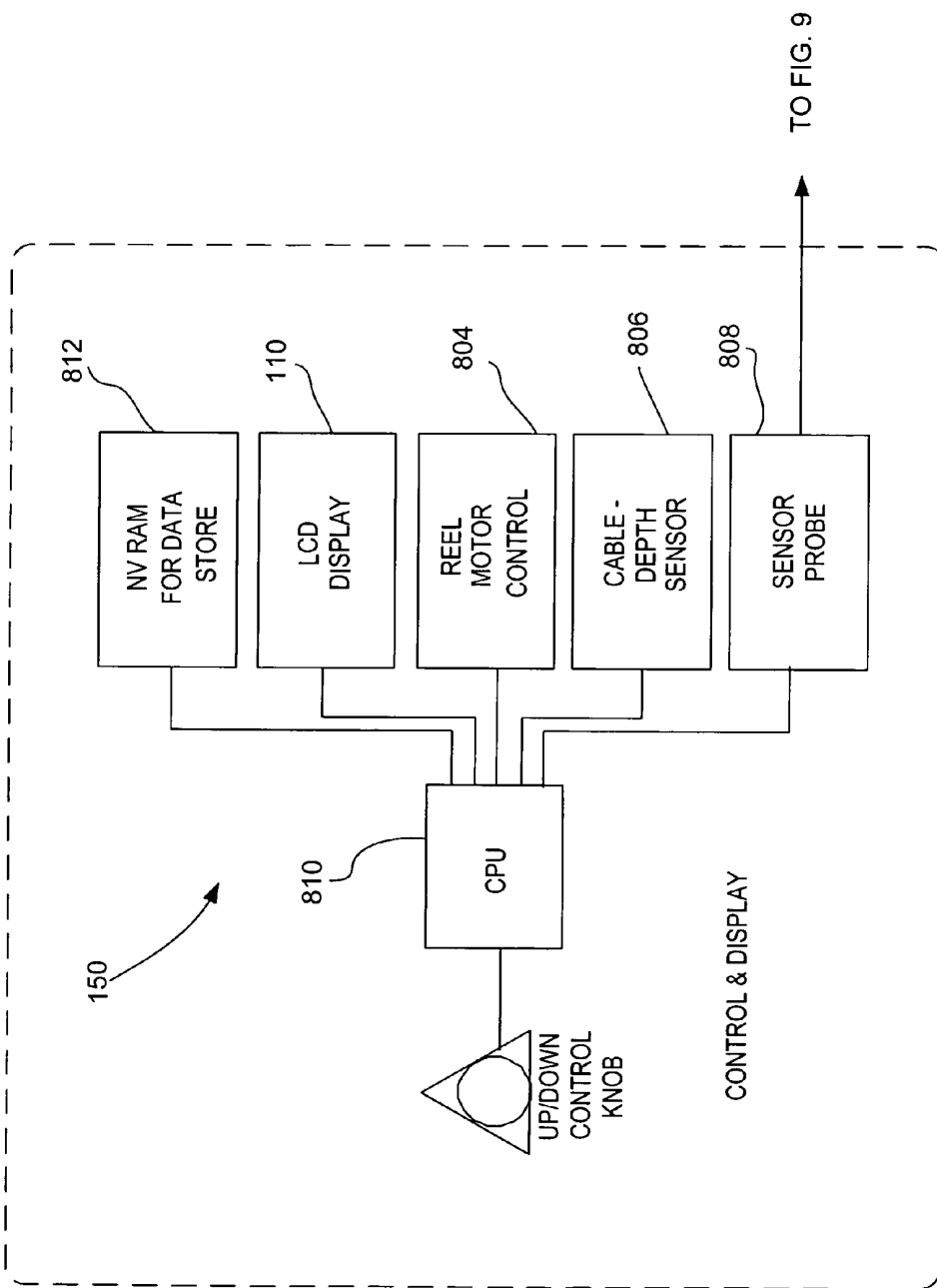
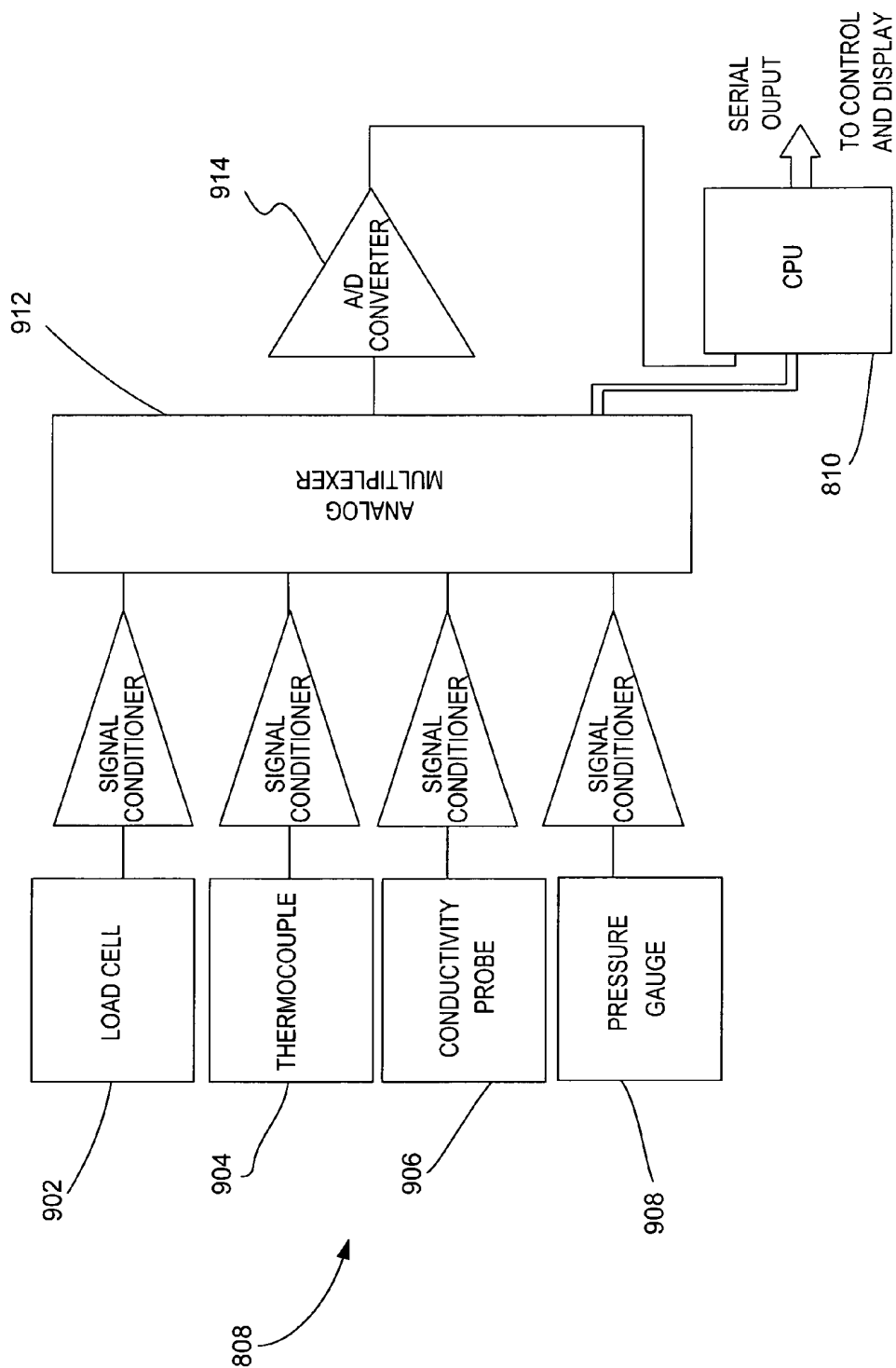

FIG. 9



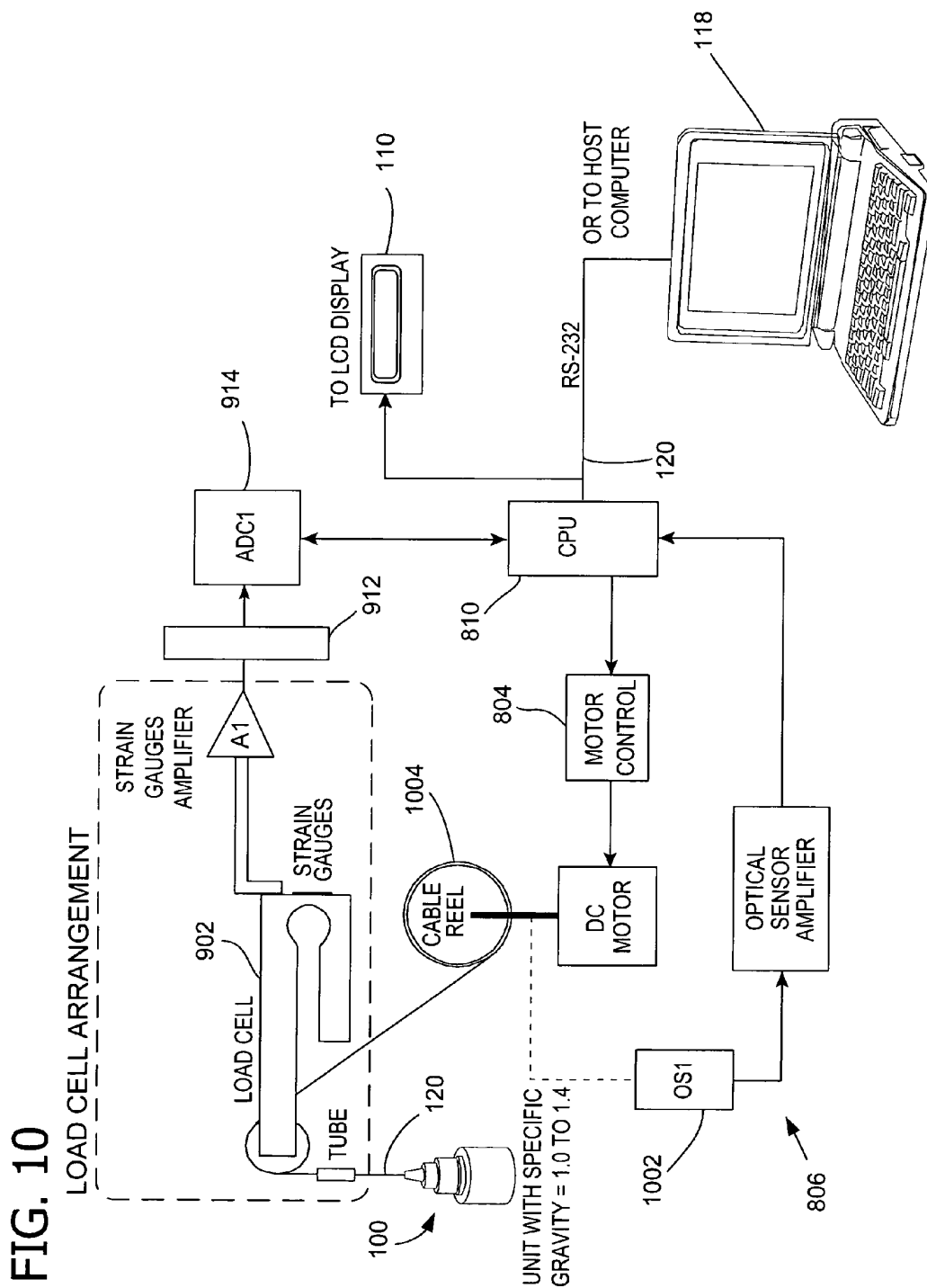
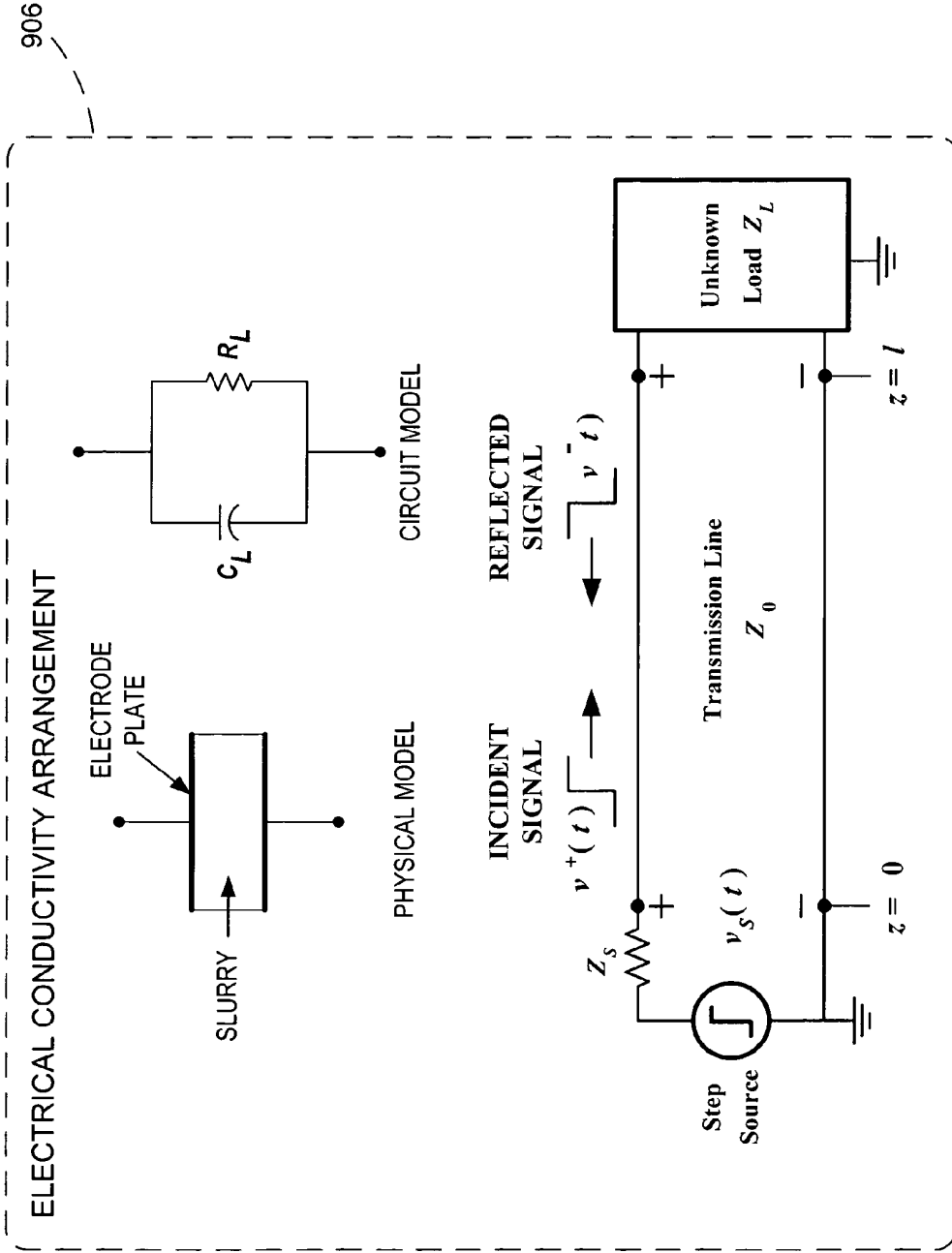

FIG. 11



**BORESCOPE FOR DRILLED SHAFT
INSPECTION****CROSS REFERENCE TO RELATED
APPLICATION**

This application is a continuation-in-part of application Ser. No. 09/409,450, filed Sep. 30, 1999 now abandoned, which claims the benefit of provisional application Ser. No. 60/102,408, filed Sep. 30, 1998, the entire disclosures of which are incorporated herein by reference.

BACKGROUND OF THE INVENTION

The invention relates generally to a borescope system for use in inspecting drilled shafts, also referred to as bores or boreholes. In particular, the invention relates to a portable visual inspection system for inspecting relatively large drilled construction shafts and the like that provides improved efficiency in terms of maneuverability, information gathering, data recording, data analyzing, and data quantifying.

Drilled construction shafts that are subsequently filled with concrete or similar materials provide support for many large building projects. For this reason, field engineers and inspectors involved in preparing such shafts are particularly concerned with ensuring that the load transfers in side resistance and in end bearing are consistent with any assumptions made during the design phase. Normally, project design methods assume that drilled shafts are constructed under competent supervision and with ample quality control and assume that the finished foundation will be durable and have structural integrity. However, such assumptions are not always warranted. Unless project specifications and procedures are closely followed in the field, for example, the final shaft may have defects that can influence its structural and bearing capacity when filled. Therefore, the inspection of drilled shafts and the record keeping associated with shaft construction are important and require careful attention.

Defects of a finished support structure and the conditions under which such defects occur may involve a number of causes. For example, defects typically result from one or more of the following: 1) over stressing the soil beneath the shaft base due to insufficient bearing (contact) area or because of unconsolidated materials located at the shaft base; 2) excessive mixing from mineral slurry, which can affect the development of concrete strength and/or formation of voids and cavities within the set concrete; and 3) structural discontinuities and/or deviations from the true vertical line causing local, undesirable stress concentrations. In general, these and other defects can result in insufficient load transfer reducing the bearing capacity of the final structure and/or causing excessive settling during service.

To develop the required end bearing capacity, the drilled shaft should be inspected so that undesirable debris may be removed before concrete placement. Shaft failures have been attributed to insufficient borehole cleaning, and cleaning the base of boreholes often requires special tools. Although the operation sounds simple, a typical cleaning process involves several steps including visually inspecting the borehole, sounding the base of the shaft by a weight attached to a chain, and obtaining samples of the side walls and the base. Based on the results of the visual, sounding, and sampling inspections, a trained inspector decides whether the borehole must be cleaned or otherwise altered before concrete placement. The inspector usually bases his

or her decision on the condition of the borehole and the amount of sedimentary deposits at the base. If the inspector decides that cleaning is warranted, several methods may be used, including air lifting, using a clean-out-bucket, or removing debris and unwanted material with a submerged pump. The cleaning requirements can be quite strict. For example, the Florida Department of Transportation requires that at least 50 percent of the base of each shaft have less than 0.5 inches (13 mm) of sediment at the time of concrete placement, and that the maximum depth of sedimentary deposits or any other debris at any place on the base of the shaft not exceed 1.5 inches (40 mm).

As may be expected, verifying the conditions existing at the shaft base is often a difficult task. Lowering a human inspector into a borehole, especially one that has been stabilized with slurry, can be very dangerous or even impossible. Thus, to facilitate the inspection process and to avoid sending human inspectors into large construction boreholes, highway agency guidelines often recommend the use of a shaft inspection device. The Florida Department of Transportation, for example, recommends the use of its Shaft Inspection Device (SID), developed in the early 1980s by Schmertmann and Crapps, Inc. The SID comprises a television camera sealed inside a water-tight jacket and is used for inspecting both dry and wet excavations. The concept of the SID was derived from an Australian drilled shaft inspection device originally developed by Dr. Jim Holden of the Country Roads Board.

Since its inception, the SID has been used with only modest success. The SID weighs approximately 10,000 pounds, is quite large, and is relatively expensive. Although the idea of utilizing an optical device to inspect drilled shafts has been favored by engineers and contractors, the operation of present devices like the SID is cumbersome, time consuming, expensive, and often produces disappointing results, especially on drilled shaft projects in waterways. In addition to the high cost of the device itself, the SID's lack of mobility and versatility, particularly in waterways projects, results in higher operating costs.

For these reasons, a portable visual inspection system for drilled shaft inspection with improved efficiency in terms of portability, information gathering, data recording, and quantifying the obtained measurements is desired. Such a system benefits from advancements in many technologies, including imaging, fiber optics, and computers and signal processing, as well as from the development of various types of miniature video scopes and borescope devices.

SUMMARY OF THE INVENTION

Embodiments of the invention overcome one or more deficiencies in the prior art by providing, among other things, an improved system for reliably and accurately visually inspecting relatively large construction boreholes such as those prepared for building drilled shaft foundations. The invention advantageously provides a visual inspection of the adequacy of boreholes (e.g., their bottom and sides) to construct deep foundations or slurry walls. Embodiments of the invention also determine the strength of the materials at the bottom of the boreholes as well as the physical and electrical properties, the pressure, and the temperature of the slurry in the borehole. This is accomplished by a portable system utilizing a miniature charge coupled device (CCD) camera in a watertight assembly and a miniature penetrometer. The system of the present invention provides a smaller and lighter device for drilled shaft inspection that a single user can operate. Further, the invention does not require a

complicated assembly but can be assembled on-site just prior to use. In one embodiment, an improved inspection system of the invention collects data in analog and/or digital form and is capable of providing digital information to a computer. Thus, it is economical in terms of the number of required personnel and efficient in storing and retrieving the needed information. Advantageously, the present invention is particularly well-suited for inspection in waterways projects and even provides clear vision in environments where visibility is limited. Moreover, the features of the present invention described herein are less laborious and easier to implement than currently available techniques as well as being economically feasible and commercially practical.

Briefly described, a system for inspecting a borehole embodying aspects of the invention includes a portable camera in a housing adapted to be lowered into the borehole. The camera, which has a defined viewing area, generates images of at least a portion of an interior surface of the borehole and generates signals representative of the generated images. The system also includes a sensor for use with the housing for sensing a physical characteristic of the borehole and a computer receiving and responsive to the signals from the camera and the sensed physical characteristic for inspecting the borehole.

Another embodiment of the invention involves a method of inspecting a borehole that contains a slurry. The method includes lowering a camera assembly into the slurry and determining a velocity at which the camera assembly is lowered. The method also includes measuring a buoyant weight of the camera assembly in the slurry and determining a density of the slurry as a function of a comparison between the measured buoyant weight of the camera assembly in the slurry and a reference weight of the camera assembly in air.

Another embodiment of a system for visually inspecting an interior surface of a construction borehole according to the invention includes a camera assembly, a load cell, and a computer. The camera assembly in this embodiment includes a portable camera for generating images of the interior of the borehole and for generating signals representative of the generated images. A housing provides the camera with viewing access and is adapted to be lowered into the borehole. The camera assembly also includes a viewing envelope positioned adjacent the camera and external to the housing. The viewing envelope has a transparent shell defining a fluid chamber and defining a viewing area adjacent the camera. A light source illuminates the viewing area, which enables the images of an interior surface of the borehole to be generated by the camera. Also, the viewing envelope has width substantially less than a width of the construction borehole. The load cell measures a buoyant weight of the camera assembly in a slurry relative to a reference weight of the camera assembly in air and the computer determines a density of the slurry in the borehole from the measured buoyant weight.

Yet another embodiment of the present invention relates to a system for visually inspecting a construction borehole. The system includes a portable camera for generating images of a portion of an interior surface of the borehole and a light source for illuminating a viewing area adjacent the camera. The light source enables the images of the interior surface of the borehole to be generated by the camera. The system also includes a housing for the camera and the light source that is adapted to be lowered into the bore hole. A probe for use with the housing measures a penetration of the probe on a bottom of the borehole and, in turn, determines an amount of a deposit at the bottom of the borehole. At least

one of the images generated by the camera displays the probe. Further, the system includes a monitor receiving and responsive to signals from the camera for displaying the images generated by the camera.

Alternatively, the invention may comprise various other methods and systems.

Other objects and features will be in part apparent and in part pointed out hereinafter.

BRIEF DESCRIPTION OF THE DRAWINGS

FIG. 1 is a block diagram of a borescope system for visually inspecting drilled shafts according to an embodiment of the invention.

FIG. 2 is a view of a camera assembly of the system of FIG. 1.

FIG. 3 is a view of a tilt and pan gear and of a light source of the camera assembly of FIG. 1.

FIG. 4 is a schematic view of the camera assembly of FIG. 1.

FIG. 5 is a view of an observation chamber for use with the camera assembly of FIG. 1.

FIG. 6 is a view of a penetrometer for use with the observation chamber of FIG. 5.

FIG. 7 is a schematic view of the camera assembly of FIG. 1 including the observation chamber of FIG. 5.

FIG. 8 is a block diagram of a borescope system for visually inspecting drilled shafts according to another embodiment of the invention.

FIG. 9 is a block diagram of control circuitry for use with the borescope system of FIG. 8.

FIG. 10 is a block diagram of a load cell arrangement associated with the control circuitry of FIG. 9.

FIG. 11 is a block diagram of an electrical conductivity arrangement associated with the control circuitry of FIG. 9.

Corresponding reference characters indicate corresponding parts throughout the drawings.

DETAILED DESCRIPTION OF THE INVENTION

Referring now to the drawings, FIG. 1 illustrates a borescope system in block diagram form. As shown, the system includes a camera assembly **100** connected to a video monitor **110** (e.g., a relatively small, portable television) for visually inspecting a borehole. A typical borehole is several feet in diameter (e.g., about nine feet) and has an even greater depth (e.g., about 150 feet). It is to be understood, however, that a borehole describes any opening in the ground that has either a generally cylindrical geometry of a few inches to several feet in diameter and depth or a generally rectangular cutoff wall in the ground with a few inches to several feet in width/depth. The borehole can be dry or wet (at least partially filled with transparent, translucent, or opaque fluid). The borehole can be self supported, cased, or a pipe pile. The ratio of the size of the borehole to the camera chamber can be 1:1 or 28:1.

As described in detail below, the present system may be used to visually inspect the adequacy of boreholes (bottom and sides) to construct deep foundations or slurry walls. In addition, the system is able to determine the strength of the materials at the bottom of the boreholes by using a miniature penetrometer; and to determine the physical and electrical properties, the pressure, and the temperature of the slurry in the borehole.

According to embodiments of the invention, the camera assembly **100** generates images of the shaft's interior sur-

faces while suspended in the borehole. As illustrated, the video monitor **110** has a video recorder **112** (e.g., a video cassette recorder, digital video recorder or other recording system) for recording the video images captured by camera assembly **100** in analog form or digital form depending on the video format. In one embodiment, the borescope system also provides a line **114** to a computer **118** for displaying and recording the captured images. In the embodiment shown, camera assembly **100** communicates with the computer **118** via a power-video-control cable **120** (also referred to as an umbilical cord). Camera assembly **100** communicates with computer **118** according to, for example, an RS232 standard. It is to be understood that computer **118** may be used in addition to or instead of the video monitor **110** and recorder **112** for recording the video images of the interior of the borehole generated by camera assembly **100**.

The borescope system of the invention also has a case **130** for housing, storing, and transporting various components of the system. Advantageously, the case **130** houses a rechargeable battery **134** for supplying power to the various components of the system. An appropriately wired connector panel **136** known to those skilled in the art provides easy electrical connections between the various components such as the battery **134**, camera assembly **100**, video monitor **110**, and/or computer **118**.

Although computer **118** is shown as a laptop computer in FIG. **1**, other computer configurations are easily adapted for use with the present invention. Moreover, computer **118** may be self-powered (e.g., independently battery powered), receive power from battery **134**, or receive power from an external source independent of the borescope system.

In the illustrated embodiment, battery **134** supplies power to video monitor **110** and recorder **112** via a monitor power connection **138** and a power line (not shown). Battery **134** also supplies power to camera assembly **100** via a camera input **140** and the power-video-control cable **120**. In the embodiment shown in FIG. **1**, the line **114** supplies a video signal to computer **118** (or another external monitor) via a video connector **142**. The connector panel **136** also includes a control input **146** described below.

As will be explained in greater detail below, a controller **150** controls camera assembly **100**. The controller **150** is connected on one side, by the umbilical cord containing power-video-control cable **120** to computer **118**. Controller **150** is connected on another side to the control input **146** on connector panel **136**. As shown in FIG. **1**, controller **150** further includes a pan controller **152** and a tilt controller **154**. Borescope system operators can manipulate the camera's position using the controllers **152** and **154**. Control signals generated by controllers **152,154** are transmitted to camera assembly **100** via power-video-control cable **120**. Additionally, the RS232 link between computer **118** and camera assembly **100** is established via controller **150**. Thus, it is possible to generate and transmit computer controlled input information to camera assembly **100** via controller **150**. Likewise, computer **118** can receive camera information, such as camera position information, from camera assembly **100** via controller **150**.

The connector panel **136** also provides access to a power supply fuse **156**, as well as a system power switch **158** and a power indicator **160**. Although it is anticipated that the borescope system will often operate using the battery **134**, the system may also be connected directly to an external power source using a power line (not shown) connected via a power connector **164**. The external power line and power connector **164** may also be used to recharge the battery **134** when the system is not being used. Although the embodi-

ment shown in FIG. **1** contemplates the use of a 12 volt power system, the borescope system of the present invention is in no way limited to 12 volt systems. Additionally, the case **130** also includes at least one storage compartment **172** for storing various components of the borescope system when the system is not in use or being transported.

Advantageously, a borescope system according to the invention permits control, measurement, and/or display of camera assembly depth, buoyant weight, and/or descending velocity as well as electrical conductivity, pressure, and/or temperature of the slurry contained in the borehole.

Referring now to FIG. **2**, camera assembly **100** includes a miniature (e.g., about the size of a highlighter pen) color or black and white charge coupled device (CCD) video camera **210**. In one embodiment, the width of camera assembly **100**, including the miniature camera **210**, is substantially less than the diameter of the borehole under inspection.

The camera **210** may be housed within a housing chamber **212** for protection. This camera assembly housing chamber **212**, generally cylindrical in this embodiment, is constructed using a rigid material such as aluminum. It is to be understood, however, that other materials, such as PVC, may be suitable for protecting camera **210**. In fact, as shown in FIG. **4** below, one embodiment of the housing chamber **212** of the present invention uses an aluminum frame enclosed in a PVC casing. An abrasion resistant transparent dome **214** provides camera **210** with viewing access while protecting the camera **210** from possible damage due to contact with the surfaces being inspected. Although the transparent dome **214** in the embodiment illustrated in FIG. **2** is constructed of plastic, any number of transparent materials could be used with the borescope system of the present invention. Power-video-control cable **120** is connected to the end of camera assembly **100** at a rear closure **216**. The rear closure **216**, in turn, connects to housing chamber **212**. Housing chamber **212**, rear closure **216**, and transparent dome **214** are assembled using methods known in the art to create a substantially watertight protective housing for the camera assembly **100**.

Referring now to FIG. **3**, the housing chamber **212** of camera assembly **100** also encloses a tilt and pan gear mechanism **310**, on which camera **210** is mounted. A system operator controls the tilt and pan gear mechanism **310** to rotate camera **210** through a wide range of motion leg (e.g., 360 degrees in-plane and 180 degrees out-of-plane). Camera rotation is explained in further detail below.

In addition to camera **210** and tilt and pan gear mechanism **310**, the housing chamber **212** also encloses an electronic control board **312** and one or more high intensity light emitting diodes **316**. Preferably, the light emitting diodes **316** provide sufficient illumination to enable camera **210** to capture images of the interior of the borehole under inspection. The control board **312** controls camera **210** and tilt and pan gear mechanism **310** in response to operator inputs from controller **150** via power unit **132** and power-video-control cable **120** (see also FIG. **1**). By manipulating tilt and pan gear mechanism **310**, also referred to as a motion control mechanism, the operator can control and direct a camera viewing angle or line of sight, which in turn enables the operator specify areas of the borehole for viewing and inspection.

FIG. **4** is a schematic illustrating certain detailed aspects of the camera assembly **100** of a borescope system according to the present invention. As shown in FIG. **4**, the camera assembly housing chamber **212** supports tilt and pan gear mechanism **310** which includes a vertical servo motor **410**

for tilting camera **210** and a horizontal servo motor **412** for rotating it. The functionality of tilt and pan gear mechanism **310** may be further described by reference to the vertical servo motor **410** and the horizontal servo motor **412**. The tilt mechanism and vertical servo motor **410** constitute a first rotational motion stage for rotating camera **210** in a plane defined by a vertical axis *y* relative to the housing chamber **212**, i.e., tilting camera **210** up to approximately 180 degrees (± 90 degrees), as camera **210** is suspended in the borehole. Likewise, the pan mechanism and horizontal servo motor **412** constitute a second rotational motion stage for rotating camera **210** about the vertical axis *y* over approximately 360 degrees as camera **210** is suspended in the borehole.

Referring to both FIG. 3 and FIG. 4, control board **312** provides servo motors **410**, **412** with electrical control signals in response to operator inputs from the tilt and pan controllers **152, 154** of controller **150** (see FIG. 1). In particular, control board **312** includes a micro-controller with an analog-to-digital (A/D) converter and a pulse width modulation output driver. The micro-controller receives analog input signals from tilt and pan controllers **152, 154** and converts the received signals to pulse width modulated output signals for accurately controlling the position of servo motors **410, 412** using control and driver techniques that are known in the art.

FIG. 4 further illustrates housing chamber **212** previously described with respect to FIG. 2. As shown in FIG. 4, housing chamber **212** is comprised of a generally cylindrical aluminum frame **414** enclosed in a generally cylindrical PVC casing **416**. Generally disk-shaped PVC end caps **418** are used to enclose each end of housing chamber **212**.

In an alternative embodiment, aluminum stands (not shown) support camera assembly **100** on the bottom of the borehole to be inspected. Aluminum brackets (not shown) may be attached to the PVC casing **416** to provide additional support for housing chamber **212** and for receiving and supporting the aluminum stands.

In another embodiment, the borescope system employs a fluid-filled viewing envelope **510** as shown in FIG. 5 connected to housing **212**. The viewing envelope **510**, also referred to as an observation chamber, is particularly well-suited for use in slurry-filled boreholes. As is known in the art, boreholes are often filled with a viscous mud, or slurry, especially in waterways projects. The slurry, however, obscures the view of the side walls and bottom of the filled borehole. According to the invention, the viewing envelope **510** is attached to the camera assembly **100** and filled with a clear liquid such as water. The camera **210** is separated from the fluid by the transparent dome **214**.

Fluid describes materials of gas or liquid nature. A fluid chamber (i.e., viewing envelope **510**) can be used to inspect the verticality of a borehole and quantitatively determine the angle of tilt of the borehole (using a horizontal air bubble or a laser beam attached to the fluid chamber). The viewing envelope **510** consists of either a rigid or a flexible transparent material. Moreover, viewing envelope **510** is either closed end or open end. For example, in a dry borehole, it may be desired to detach the chamber from the camera assembly and the inspection can be carried out with camera assembly **100** alone.

The present invention may be used to determine the adequacy of the boreholes. Cleanliness of the bottom and sides of the borehole from any soil or rock residues is an important factor for determining whether the borehole is adequate for constructing deep foundations or slurry walls. Also, the concept of borehole adequacy describes cracking in pipe piles or defects in borehole casing.

Advantageously, the fluid in viewing envelope **510** provides camera **210** with a viewing interface. In operation, the operator lowers camera assembly **100**, with viewing envelope **510** attached, into a slurry-filled borehole. By moving the assembly **100**, particularly the viewing envelope **510**, into contact with the side walls or bottom of the borehole, the operator is able to obtain images of the borehole's interior surface even though the assembly **100** is submerged in the slurry. In this manner, viewing envelope **510** defines a viewing area of the camera **210** in situations where a camera could not otherwise view the walls or bottom of the borehole.

In addition to providing a clear viewing interface, the water in viewing envelope **510** counters the pressure of the slurry against its surface and adds weight to the overall assembly **100**. This helps stabilize camera assembly **100** and is an improvement over an air-filled observation chamber. As illustrated in FIG. 5, viewing envelope **510** is a generally cylindrical structure constructed of rigid, transparent plastic or a similar material. In an alternative embodiment, viewing envelope **510** is made of a flexible, durable, transparent plastic. In this alternative embodiment, the water contained in the viewing envelope **510** sufficiently maintains the chamber's volume while the flexible plastic more uniformly conforms to the non-uniform interior surface of the borehole.

FIG. 6 shows a penetrometer **610** for use with viewing envelope **510**. In this embodiment, the penetrometer **610** measures the stiffness of the bottom of the borehole with, for example, a spring-loaded steel bar assembly **620** projecting therefrom having a graduated steel bar **622** connected to a spring **624**. If the bottom of the borehole is relatively stiff, or solid, it will provide resistance and push up the steel bar **622** and likewise compress the spring **624**. On the other hand, if the bottom of the borehole is soft, it will not provide as much resistance and, thus, will push the steel bar **622** and compress the spring **624** by lesser amounts. The penetrometer **610**, which may be mounted on a surface of the viewing envelope **510**, for example, is calibrated to measure stiffness as a function of the amount of deflection of the spring-loaded steel bar assembly **620**. It should be understood, however, that penetrometer **610** could be employed separately, without viewing envelope **510**.

FIG. 6 further shows a viewing envelope **510** that includes graduated scale markings **630**. The graduated scale markings **630** would be captured by the video camera and could be used to take relative measurements. For example, the size of a shaft anomaly could be measured against graduated scale markings **630**. In this instance, the invention identifies any debris existing at the bottom of the shaft and is able to measure the debris for acceptance using the vertical and horizontal graduated scale **630** of viewing envelope **510**.

The penetrometer **610**, along with viewing envelope **510**, can be used to determine the thickness of the sediments and the unconfined strength of the materials at the bottom of the borehole. Penetrometer **610** can be mechanical with a calibrated spring or pneumatic.

FIG. 7 is a schematic view of the camera assembly of FIG. 1 including viewing envelope **510**, and illustrating further details of the invention. In this embodiment of the present invention, viewing envelope **510** forms a graduated observation chamber marked with vertical and/or horizontal scaling. It is to be understood that viewing envelope **510** may be open-ended or closed-ended. If closed-ended, it may be desired to fill the observation chamber with water or another transparent liquid. In an alternative embodiment, an air line **704** supplies pressurized air to the observation chamber.

Those skilled in the art will appreciate the importance of measuring several physical characteristics of the slurry. FIG. 8 illustrates further aspects of a borescope system according to the invention in which computer 118 cooperates with controller 150 and monitor 110 (e.g., a liquid crystal display panel). In operation, a reel motor control 806 is responsive to user input via controller 150 for raising or lowering camera assembly 100 within a borehole under inspection. A cable depth sensor 806 provides information regarding the depth of camera assembly 100 at any given instant as it drops into the drilled shaft. In addition, one or more sensor probes 808 (see FIG. 9) may provide information to central processing unit 810 regarding any of a number of characteristics of the borehole. A memory 812 associated with computer 118 stores the gathered information in this embodiment of the invention.

In other words, FIG. 8 shows the components of a control and display unit according to embodiments of the invention. For example, sensor probes 808 encompass sensors and measurements shown in FIG. 9, including load cell 902 (for unit weight and viscosity measurements) (see FIG. 10); thermocouple 904 (for temperature measurement); conductivity probe 906 (for electric conductivity measurement of the slurry) (see FIG. 11); and pressure gauge 908 (for slurry pressure measurement). Those skilled in the art are familiar with thermocouples and pressure gauges suitable for use with the invention.

Referring now to FIG. 9, the sensor probe 808 may constitute one or more sensors including, but not limited to, a load cell 902, a thermocouple 904, a conductivity probe 906, and a pressure gauge 908. For example, the pressure gauge 908 measures pressure on camera assembly 100 as exerted by the slurry in the borehole and the thermocouple 904 measures temperature of the slurry. As shown, the control circuitry of FIG. 9 conditions the sensor signals and prepares them for processing by computer 118. For example, the analog sensor signals are conditioned and then multiplexed by an analog multiplexer 912 before being converted to digital signals by an analog/digital converter 914 for processing by computer 118. The load cell arrangement, including load cell 902, along with the reel motor control 804 and the cable depth sensor 806 are used to measure the unit weight, the viscosity of the slurry, and the depth at which the measurements are taken.

FIG. 10 shows an exemplary load cell arrangement including the load cell 902 of FIG. 9 for obtaining unit weight and viscosity measurements. Advantageously, the load cell arrangement permits determination of the unit weight and the viscosity of the slurry fluid, at different depths, as a function of the slurry's physical properties. For example, camera assembly 100 including the fluid chamber (i.e., viewing envelope 510) has a predetermined specific gravity that ranges from 1 to 1.4. Based on the anticipated density of the slurry fluid in the borehole, the camera chamber size 212 can be selected to get the desired specific gravity (1 to 1.4). This specific gravity of the borescope is very important to determine the unit weight and the viscosity of the slurry fluid in the borehole.

The camera assembly 100, including viewing envelope 510, can be lowered in the slurry fluid under a substantially constant velocity (i.e., a controlled fall). At different depth intervals, a control unit at the surface such as computer 118 detects its depth and buoyant weight from which the unit weight of the slurry can be determined. A digital readout unit at the surface displays the relationship between depths versus unit weight. In one embodiment, load cell 902, according to the arrangement of FIG. 10, determines the

weight of camera assembly 100 and the cable depth sensor 806 determines its depth. For example, cable depth sensor 806 comprises an optical wheel sensor 1002 associated with a cable reel 1004 used for raising and lowering camera assembly 100 by its umbilical cord 120.

Referring now to FIG. 11, an exemplary electrical conductivity arrangement including the conductivity probe 906 is shown. Advantageously, the present invention determines at least one electrical property of the slurry such as its electrical conductivity. Conductivity probe 906 in one embodiment extends from viewing envelope 510 for measuring electrical conductivity of the slurry with the depth. Measurements of the electrical conductivity are displayed on the control unit.

In yet another embodiment, camera assembly 100 includes a soil sampler (not shown) for use with viewing envelope 510 in addition to or instead of the penetrometer 610.

The invention assists in determining the suitability of a drilled shaft borehole for pouring concrete without the need for sending an inspector or diver to inspect the bottom or sides of the hole. Additionally, data is stored on video recorder 112 and/or computer 118, or on similar recording devices. The stored data can be used on site or during subsequent analysis in assessing the load carrying capacity of drilled shafts.

Moreover, the borescope system of the present invention provides qualitative as well as quantitative measurements to assist in determining the amount of sedimentary deposits and contamination in the boreholes rather than relying on the personal judgment of the drilled shaft inspector. When the invention is employed using a computer with MPEG or similar capability, the analog video images may be converted to digital images that an inspector or analyst can manipulate using digital filters, for example, to extract information that may not be detectable from a visual inspection of the shaft surfaces. For example, each pixel in an image would be mapped and given a value based on its optical characteristics. An image processor would then process the pixel data. In an alternative embodiment, a digital video camera may be used that provides both a video image as well as digital information regarding the image. Digital filtering and image processing techniques suitable for use with the present invention are known in the art and need not be described further herein.

The invention also has the advantage of advanced maneuverability. The operator can maneuver the video camera at various angles allowing inspection of the side walls of the shaft. Conventional inspection devices cannot perform this function. Furthermore, these processes can be conducted and monitored in real time and records can be stored digitally and/or reproduced on hard copies for later analysis and final reporting. Also, the digitized images and data can be added to a data base on drilled shaft construction and used to improve existing design/construction methods. This device provides engineers with an alternative to the SID at a much lower cost and with higher efficiency and productivity.

In one embodiment, the system comprises a portable inspection unit that can be transported and operated by a single inspector. Reconfiguring the basic unit to accommodate additional inspection sensors is also contemplated. Such sensors include probes to obtain soil specimens for further inspection, probes to measure penetration resistance of the bottom soil, or ultrasound or similar penetrating sensors to gather information below surficial sediments.

These additions are regarded as accessories and may be added to the basic unit when field conditions require such accessories.

Advantageously, such a system provides both portability and versatility to facilitate the process of shaft inspection in a timely manner. Thus, one or two inspectors can perform the job with great efficiency and without causing delays in the construction stage of the drilled shafts. Furthermore, the borescope system of the present invention is not limited to vertical drilled shafts and may be used to inspect non-vertical shafts by adjusting or substituting the structure used to support and/or suspend the camera and housing into the shaft.

When introducing elements of the present invention or the embodiment(s) thereof, the articles "a," "an," "the," and "said" are intended to mean that there are one or more of the elements. The terms "comprising," "including," and "having" are intended to be inclusive and mean that there may be additional elements other than the listed elements.

In view of the above, it will be seen that the several objects of the invention are achieved and other advantageous results attained.

As various changes could be made in the above constructions, products, and methods without departing from the scope of the invention, it is intended that all matter contained in the above description and shown in the accompanying drawings shall be interpreted as illustrative and not in a limiting sense.

What is claimed is:

1. A method of inspecting a borehole containing a slurry, said method comprising:

- lowering a camera assembly into the slurry, said camera assembly having a reference weight in air;
- determining a velocity at which the camera assembly is lowered;
- measuring a buoyant weight of the camera assembly in the slurry;
- determining a density of the slurry as a function of a comparison between the measured buoyant weight of the camera assembly in the slurry and the reference weight of the camera assembly in air.

2. A system for visually inspecting an interior surface of a construction borehole containing a slurry, said system comprising:

- a camera assembly, said camera assembly comprising:
 - a portable camera for generating images of a portion of the interior surface of the borehole and for generating signals representative of the generated images;
 - a light source for illuminating an area adjacent the camera thereby enabling the images of the interior surface of the borehole to be generated by the camera;
- a housing for the camera and the light source, said housing providing the camera with viewing access and adapted to be lowered into the borehole;
- a viewing envelope positioned adjacent the camera and external to the housing, said viewing envelope comprising a transparent shell defining a fluid chamber and defining a viewing area adjacent the camera, said light source illuminating the viewing area, and said viewing envelope having a width less than a width of the construction borehole; and
- a load cell for measuring a buoyant weight of the camera assembly in the slurry relative to a reference weight of the camera assembly in air; and

a computer receiving and responsive to the measured buoyant weight for determining a density of the slurry in the borehole.

3. The system of claim 2 further comprising a video recorder for recording the images generated by the camera.

4. The system of claim 2 further comprising a monitor receiving and responsive to the signals from the camera for displaying the images generated by the camera.

5. The system of claim 2 further comprising an image processor for acquiring an image of the interior surface of the borehole from the images generated by the camera and for processing the acquired image.

6. The system of claim 5 wherein the images generated by the camera each include a plurality of pixels, said pixels each having a value representative of an optical characteristic of the images, and wherein the image processor processes the acquired image of the interior surface of the borehole as a function of the pixel values.

7. The system of claim 2 further comprising a rechargeable power supply for supplying power to the camera and/or the monitor.

8. The system of claim 2 wherein the fluid chamber of the viewing envelope is filled with water.

9. The system of claim 2 wherein the transparent shell comprises a rigid plastic.

10. The system of claim 2 wherein the transparent shell comprises a flexible plastic.

11. The system of claim 2 further comprising a rotational motion stage for tilting the camera in a plane relative to an axis of the housing.

12. The system of claim 2 further comprising a rotational motion stage for rotating the camera about an axis of the housing.

13. The system of claim 2 further comprising a probe for use with the housing for measuring penetration on a bottom of the borehole and determining an amount of a deposit at the bottom of the borehole and wherein at least one of the images generated by the camera displays the probe.

14. The system of claim 13 wherein the probe comprises a graduated bar protruding from the housing and connected to the housing by a spring, said graduated bar being in the viewing area of the camera.

15. The system of claim 2 wherein the housing includes a transparent dome through which the camera has viewing access.

16. The system of claim 2 wherein an outer width of the housing is less than the width of the construction borehole.

17. The system of claim 2 wherein the fluid chamber of the viewing envelope is filled with air.

18. A system for visually inspecting an interior surface of a construction borehole, said system comprising:

- a portable camera for generating images of a portion of the interior surface of the borehole and for generating signals representative of the generated images, said camera defining a viewing area adjacent the camera in which the images are generated;
- a light source for illuminating at least a portion of the viewing area adjacent the camera thereby enabling the images of the interior surface of the borehole to be generated by the camera;
- a housing for the camera and the light source, said housing adapted to be lowered into the borehole;
- a probe for use with the housing for measuring a penetration resistance of the probe on a bottom of the borehole and determining an amount of a deposit at the bottom of the borehole as a function of the measured

13

penetration resistance and wherein at least one of the images generated by the camera displays the probe; and a monitor receiving and responsive to signals from the camera for displaying the images generated by the camera.

19. The system of claim 18 further comprising a video recorder for recording the images generated by the camera.

20. The system of claim 18 wherein the monitor comprises a computer having a display, said computer receiving the images generated by the camera and displaying the images on its display.

21. The system of claim 20 further comprising an image processor for acquiring an image of the interior surface of the borehole from the images generated by the camera and for processing the acquired image.

22. The system of claim 21 wherein the images generated by the camera each include a plurality of pixels, said pixels each having a value representative of an optical characteristic of the images, and wherein the image processor processes the acquired image of the interior surface of the borehole as a function of the pixel values.

23. The system of claim 18 further comprising a rechargeable power supply for supplying power to the camera and/or the monitor.

24. The system of claim 18 further comprising a viewing envelope positioned adjacent the camera, said viewing envelope defining a viewing area adjacent the camera, and wherein the light source illuminates the viewing area.

25. The system of claim 24 wherein the viewing envelope comprises a transparent shell defining a fluid chamber.

26. The system of claim 25 wherein the fluid chamber of the viewing envelope is filled with water.

27. The system of claim 25 wherein the transparent shell comprises a rigid plastic.

28. The system of claim 25 wherein the transparent shell comprises a flexible plastic.

29. The system of claim 18 further comprising a motion control mechanism connected to the portable camera for

14

controlling a viewing angle of the portable camera relative to an axis of the housing and comprising a rotational motion stage for tilting the viewing angle in a plane relative to the axis of the housing.

5 30. The system of claim 18 further comprising a motion control mechanism connected to the portable camera for controlling a viewing angle of the portable camera relative to an axis of the housing and comprising a rotational motion stage for rotating the viewing angle about the axis of the housing.

10 31. A system for visually inspecting an interior surface of a construction borehole, said system comprising:

a portable camera for generating images of a portion of the interior surface of the borehole and for generating signals representative of the generated images, said camera defining a viewing area adjacent the camera in which the images are generated;

a light source for illuminating at least a portion of the viewing area adjacent the camera thereby enabling the images of the interior surface of the borehole to be generated by the camera;

a housing for the camera and the light source, said housing adapted to be lowered into the borehole;

a probe for use with the housing for measuring a penetration of the probe on a bottom of the borehole and determining an amount of a deposit at the bottom of the borehole and wherein at least one of the images generated by the camera displays the probe, and wherein the probe comprises a graduated bar protruding from the housing and connected to the housing by a spring, said graduated bar being in the viewing area of the camera.; and

a monitor receiving and responsive to signals from the camera for displaying the images generated by the camera.

* * * * *

专利名称(译)	用于钻孔轴检查的管道镜		
公开(公告)号	US7187784	公开(公告)日	2007-03-06
申请号	US10/776817	申请日	2004-02-11
[标]申请(专利权)人(译)	佛罗里达州立大学		
申请(专利权)人(译)	佛罗里达州立大学研究基金会		
当前申请(专利权)人(译)	佛罗里达州立大学研究基金会, INC.		
[标]发明人	TAWFIQ KAMAL MALLORY EDWARD J PUTCHA SASTRY TURNER DAN		
发明人	TAWFIQ, KAMAL MALLORY, EDWARD J. PUTCHA, SASTRY TURNER, DAN		
IPC分类号	G06K9/00 A61B1/04 E21B47/00 G01V1/40 G01V3/18 G01N21/954 H04N7/18		
CPC分类号	E21B47/0002 G01N21/954 E21B47/002		
助理审查员(译)	KIM, CHARLES		
优先权	60/102408 1998-09-30 US		
其他公开文献	US20040160514A1		
外部链接	Espacenet USPTO		

摘要(译)

目视检查钻孔的内表面。适于在井眼中下降的壳体支撑便携式摄像机，用于产生钻孔内表面的一部分的图像，以及用于照射邻近摄像机的区域的光源。监视器接收来自摄像机的信号，并响应于此，显示由摄像机产生的图像。位于相机附近的观察区域限制了与相机相邻的观察区域，特别是用于视觉检查填充有浆料的钻孔。

