



US 20180289344A1

(19) **United States**

(12) **Patent Application Publication**
Green et al.

(10) **Pub. No.: US 2018/0289344 A1**
(43) **Pub. Date: Oct. 11, 2018**

(54) **MULTIPLE MEDICAL DEVICE GUIDANCE**

A61B 6/03 (2006.01)

(71) Applicant: **InnerOptic Technology, Inc.,**
Hillsborough, NC (US)

A61B 8/12 (2006.01)

A61B 8/00 (2006.01)

A61B 17/34 (2006.01)

A61B 18/20 (2006.01)

A61B 18/00 (2006.01)

(72) Inventors: **Caroline Green**, Chapel Hill, NC (US);
Brian Heaney, Durham, NC (US);
Sharif Razzaque, Boulder, CO (US);
Andrei State, Chapel Hill, NC (US)

(52) **U.S. Cl.**

CPC *A61B 6/12* (2013.01); *A61B 2018/143*
(2013.01); *A61B 17/320016* (2013.01); *A61B*
90/361 (2016.02); *A61B 18/14* (2013.01);
A61B 1/04 (2013.01); *A61B 1/303* (2013.01);
A61B 1/3132 (2013.01); *A61B 5/0066*
(2013.01); *A61B 5/04* (2013.01); *A61B 6/5223*
(2013.01); *A61B 5/062* (2013.01); *A61B*
8/0841 (2013.01); *A61B 5/72* (2013.01); *A61B*
5/742 (2013.01); *A61B 5/7425* (2013.01);
A61B 5/743 (2013.01); *A61B 5/7475*
(2013.01); *A61B 18/1815* (2013.01); *A61B*
17/221 (2013.01); *A61B 34/20* (2016.02);
A61B 2034/107 (2016.02); *A61B 2090/378*
(2016.02); *A61B 5/055* (2013.01); *A61B*
5/6848 (2013.01); *A61B 6/032* (2013.01);
A61B 6/037 (2013.01); *A61B 6/463* (2013.01);
A61B 6/466 (2013.01); *A61B 6/468* (2013.01);
A61B 8/12 (2013.01); *A61B 8/4483* (2013.01);
A61B 8/466 (2013.01); *A61B 8/468* (2013.01);
A61B 8/483 (2013.01); *A61B 8/523* (2013.01);
A61B 17/3403 (2013.01); *A61B 18/20*
(2013.01); *A61B 2018/00559* (2013.01); *A61B*
2018/00577 (2013.01); *A61B 2018/1425*
(2013.01); *A61B 2018/1861* (2013.01); *A61B*
34/10 (2016.02)

(21) Appl. No.: **15/799,639**

(22) Filed: **Oct. 31, 2017**

Related U.S. Application Data

(63) Continuation of application No. 14/190,725, filed on Feb. 26, 2014, now abandoned, which is a continuation of application No. 13/753,274, filed on Jan. 29, 2013, now Pat. No. 8,670,816.

(60) Provisional application No. 61/736,789, filed on Dec. 13, 2012, provisional application No. 61/592,531, filed on Jan. 30, 2012.

Publication Classification

(51) **Int. Cl.**

A61B 6/12 (2006.01)
A61B 34/10 (2016.01)
A61B 17/32 (2006.01)
A61B 90/00 (2016.01)
A61B 18/14 (2006.01)
A61B 1/04 (2006.01)
A61B 1/303 (2006.01)
A61B 1/313 (2006.01)
A61B 5/00 (2006.01)
A61B 5/04 (2006.01)
A61B 6/00 (2006.01)
A61B 5/06 (2006.01)
A61B 8/08 (2006.01)
A61B 18/18 (2006.01)
A61B 17/221 (2006.01)
A61B 34/20 (2016.01)
A61B 5/055 (2006.01)

(57)

ABSTRACT

A system and method for providing image guidance for placement of one or more medical devices at a target location. The system receives emplacement information of medical devices within a predetermined area. The system calculates a viewing angle in a virtual 3D space of a plurality of virtual medical devices corresponding to the plurality of medical devices. The system also causes a display device to display the plurality of virtual medical devices based at least on the calculated viewing angle.

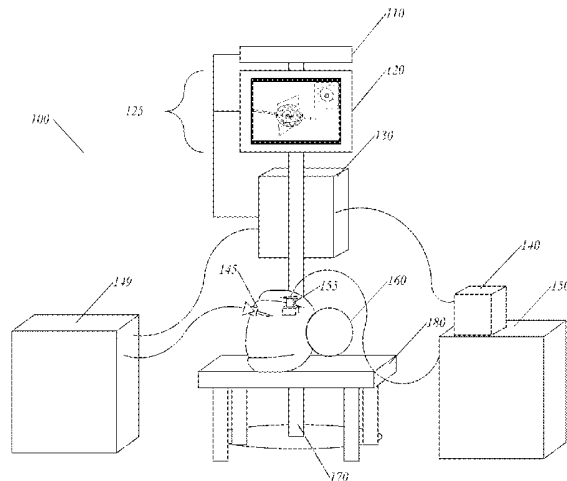

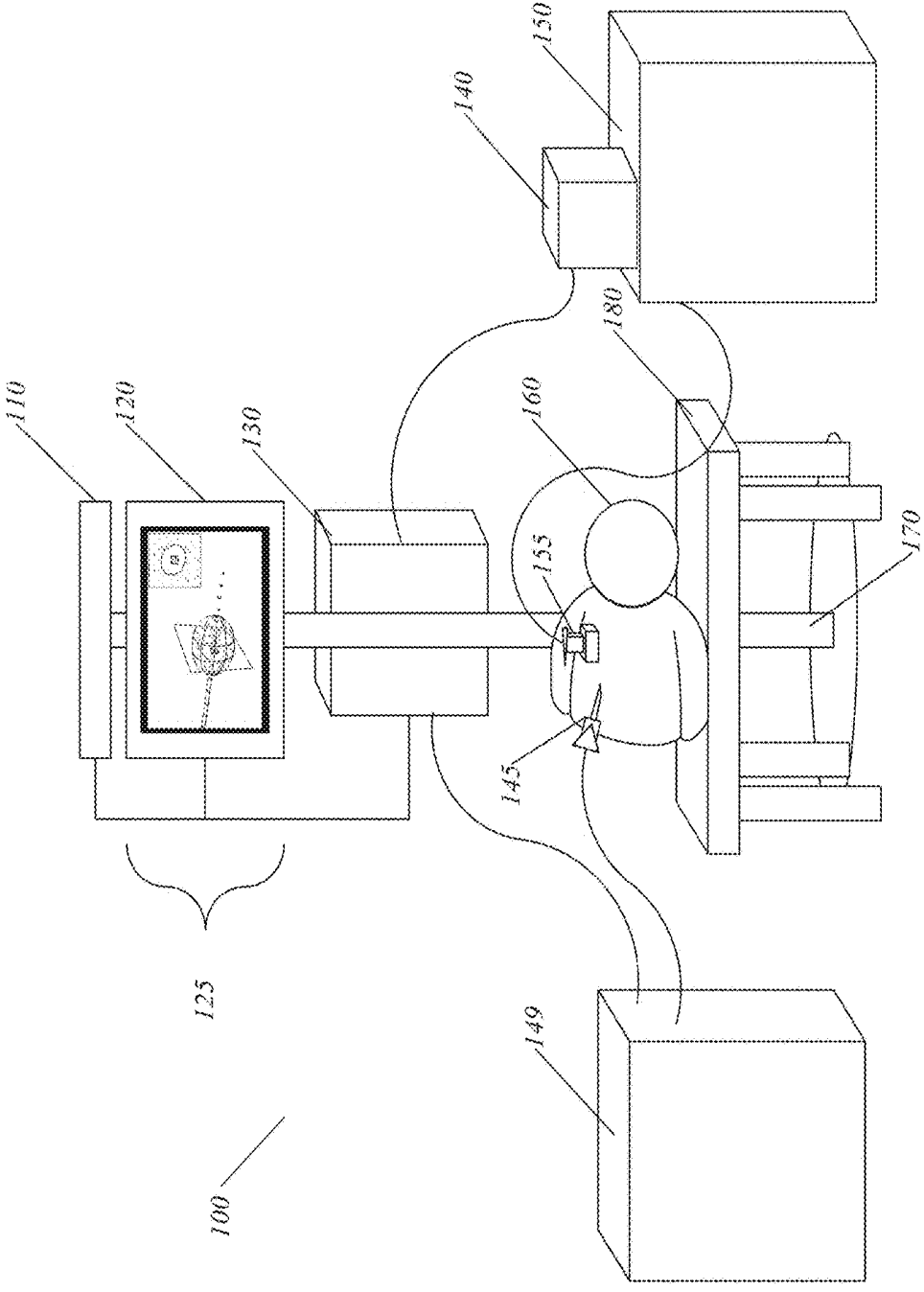

FIG. 1A

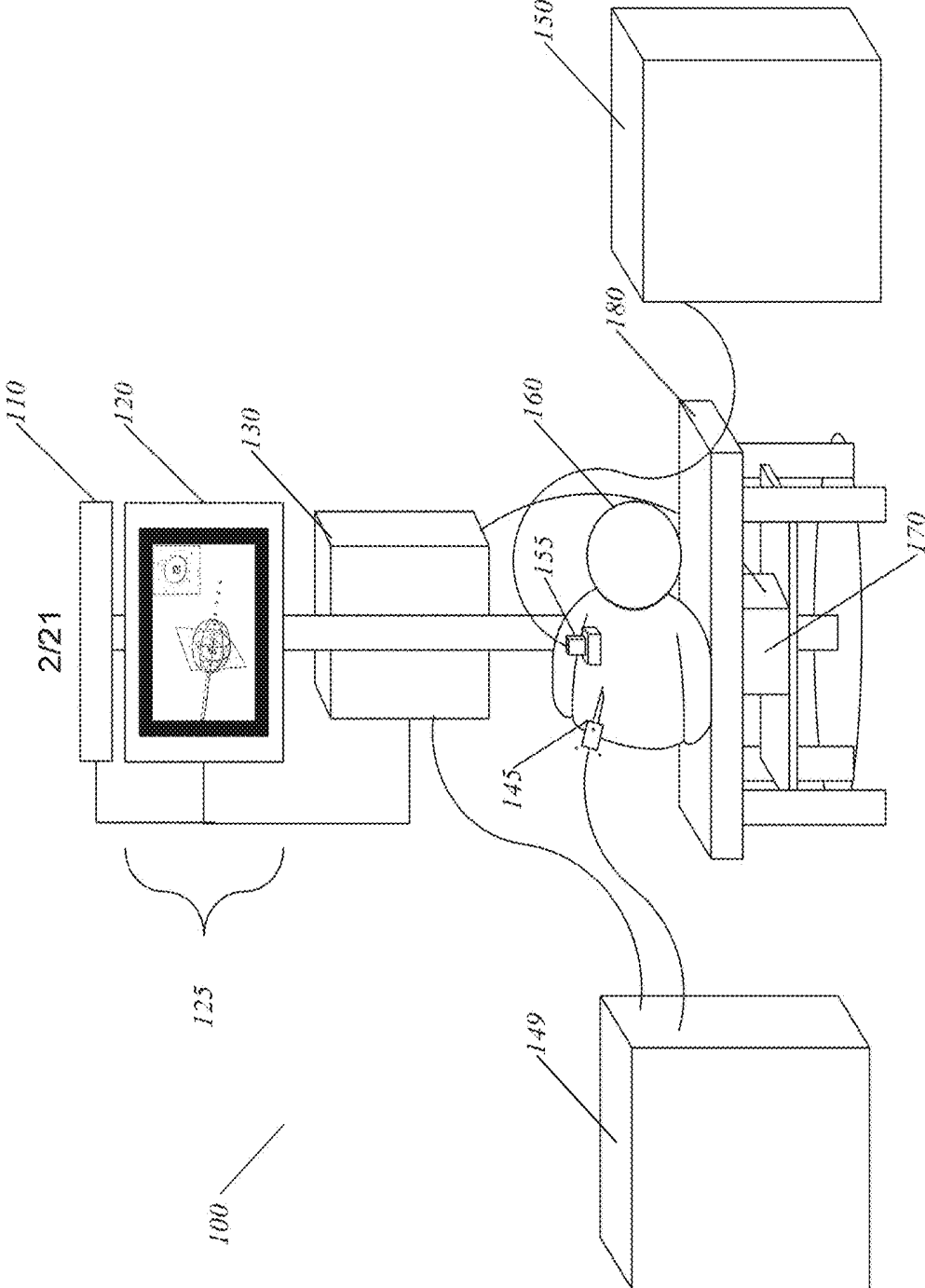

FIG. 1B

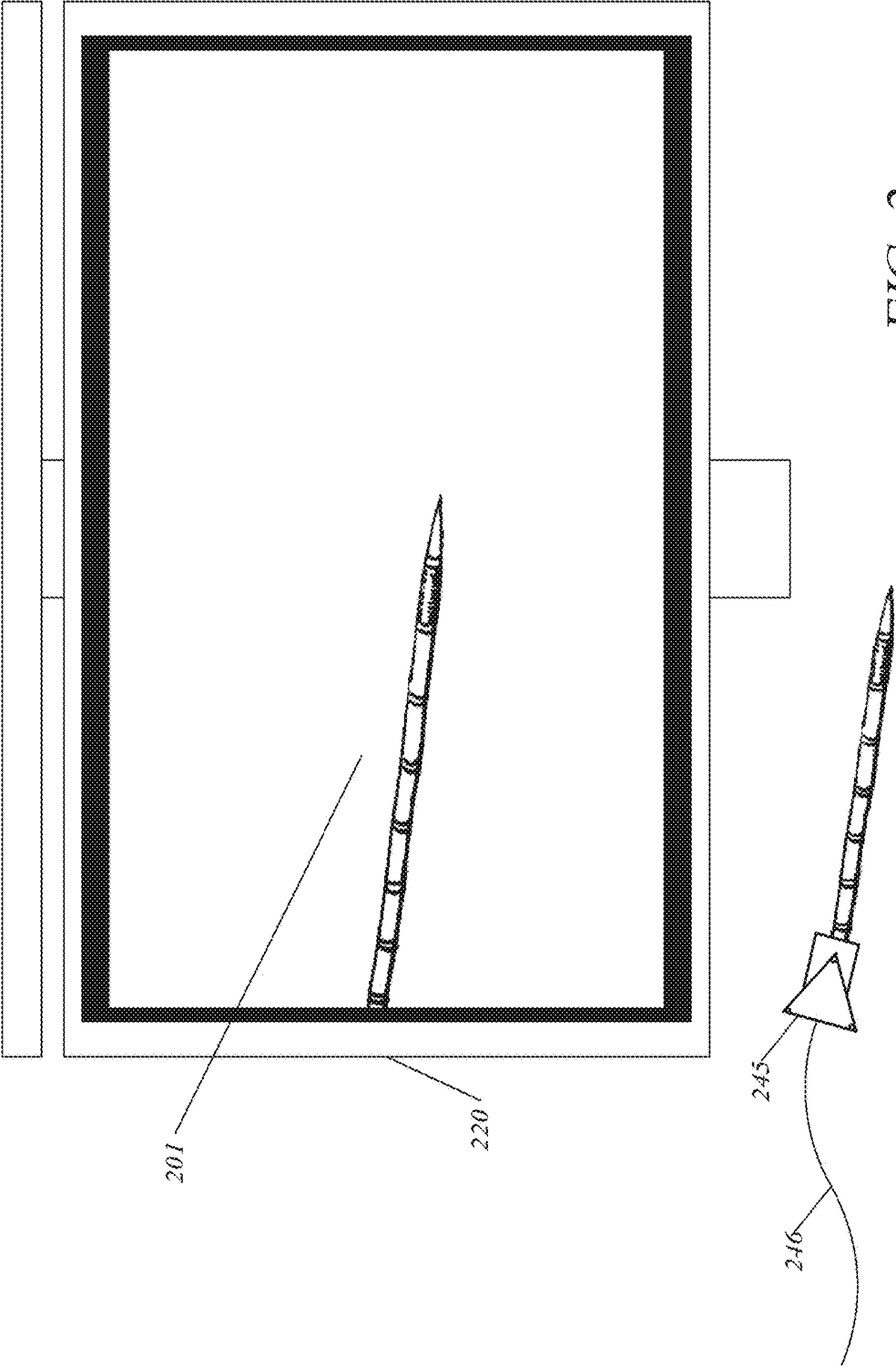

FIG. 2

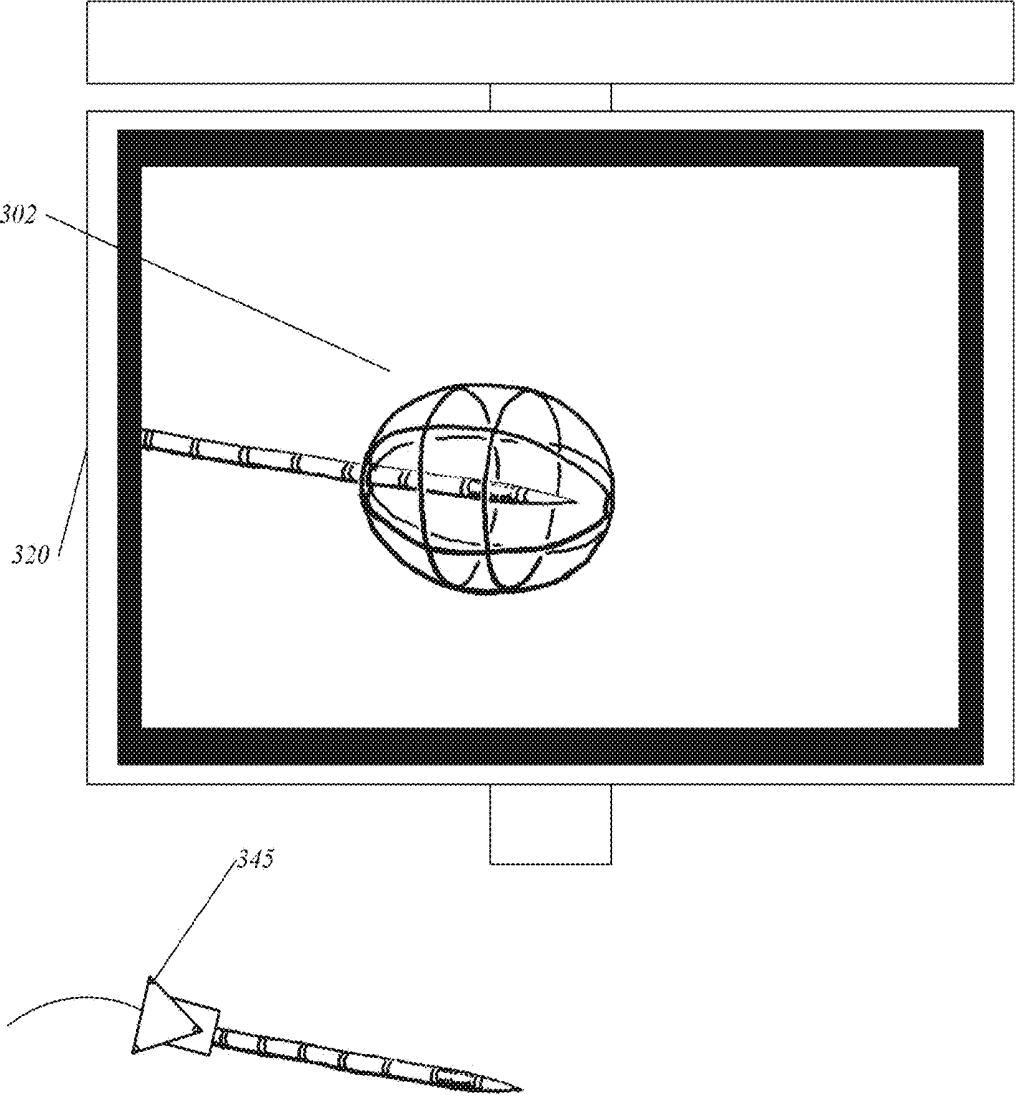

FIG. 3

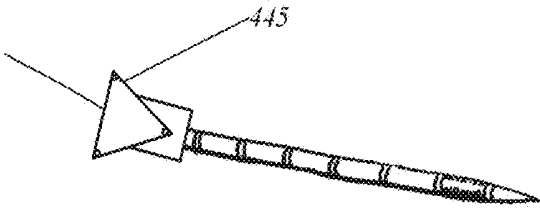
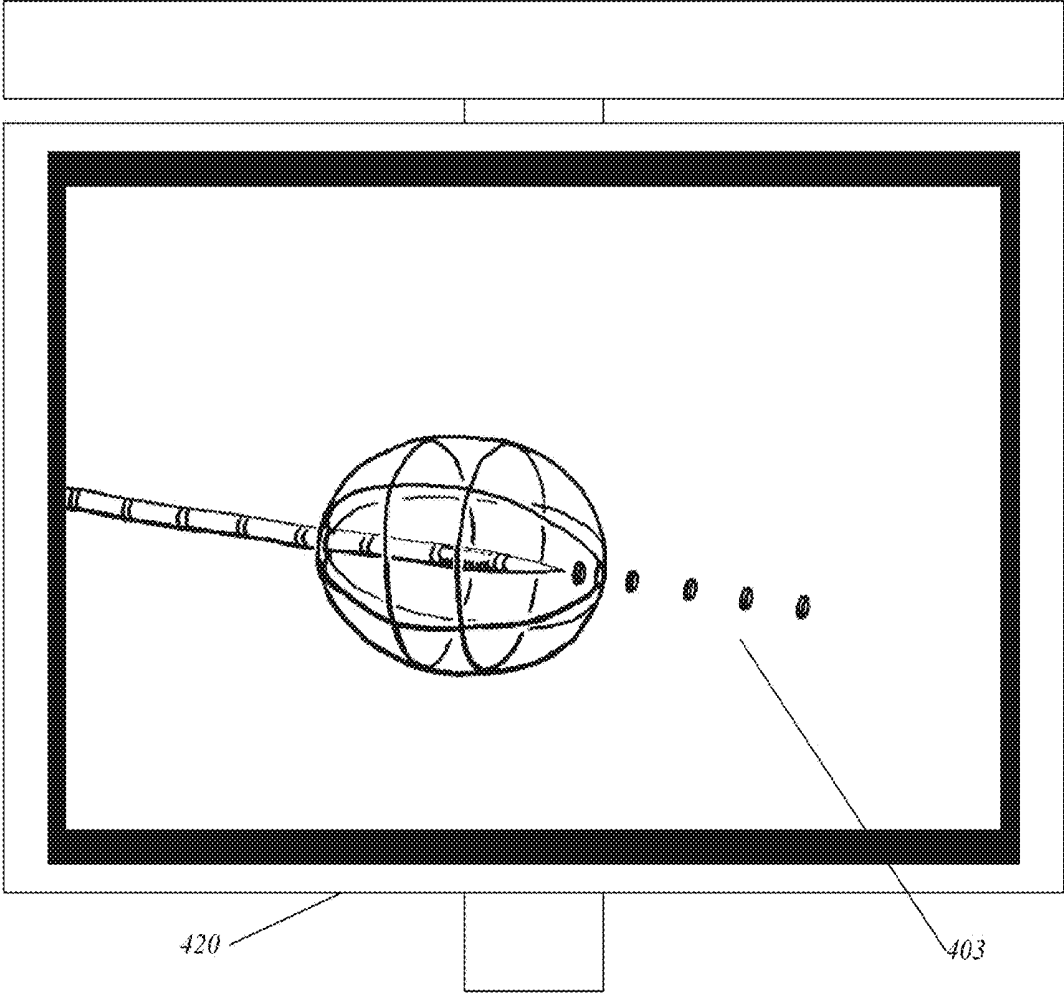
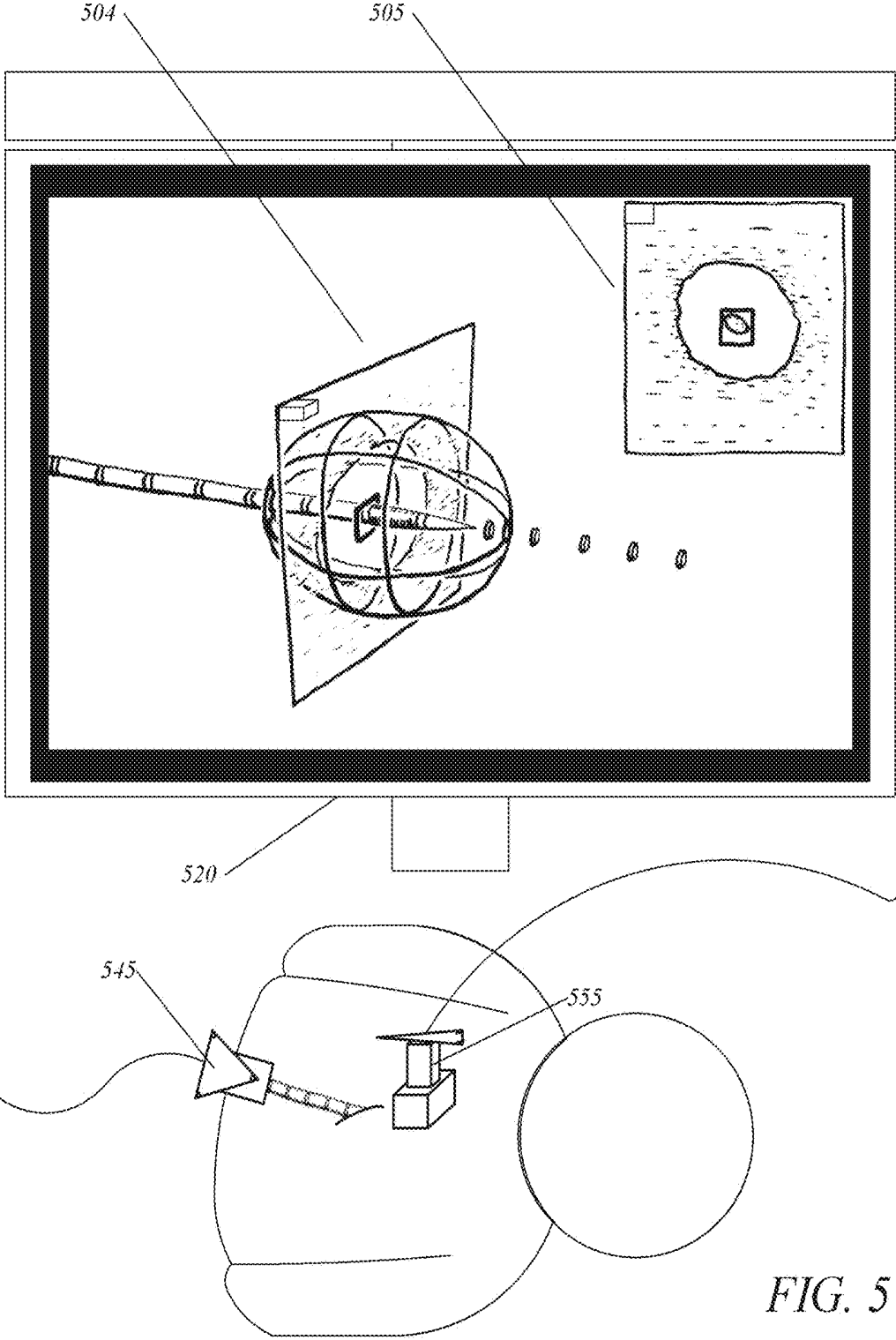

FIG. 4



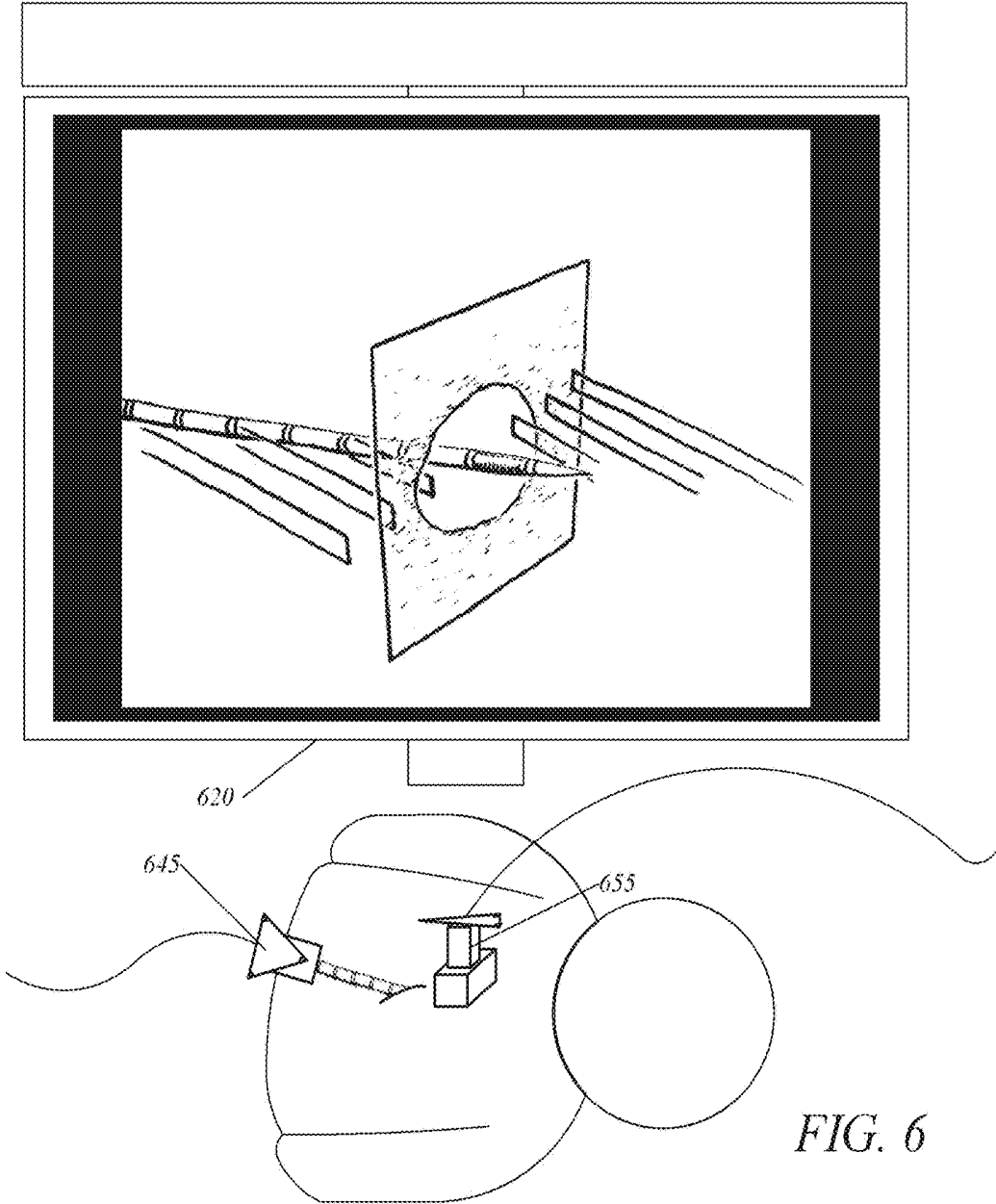
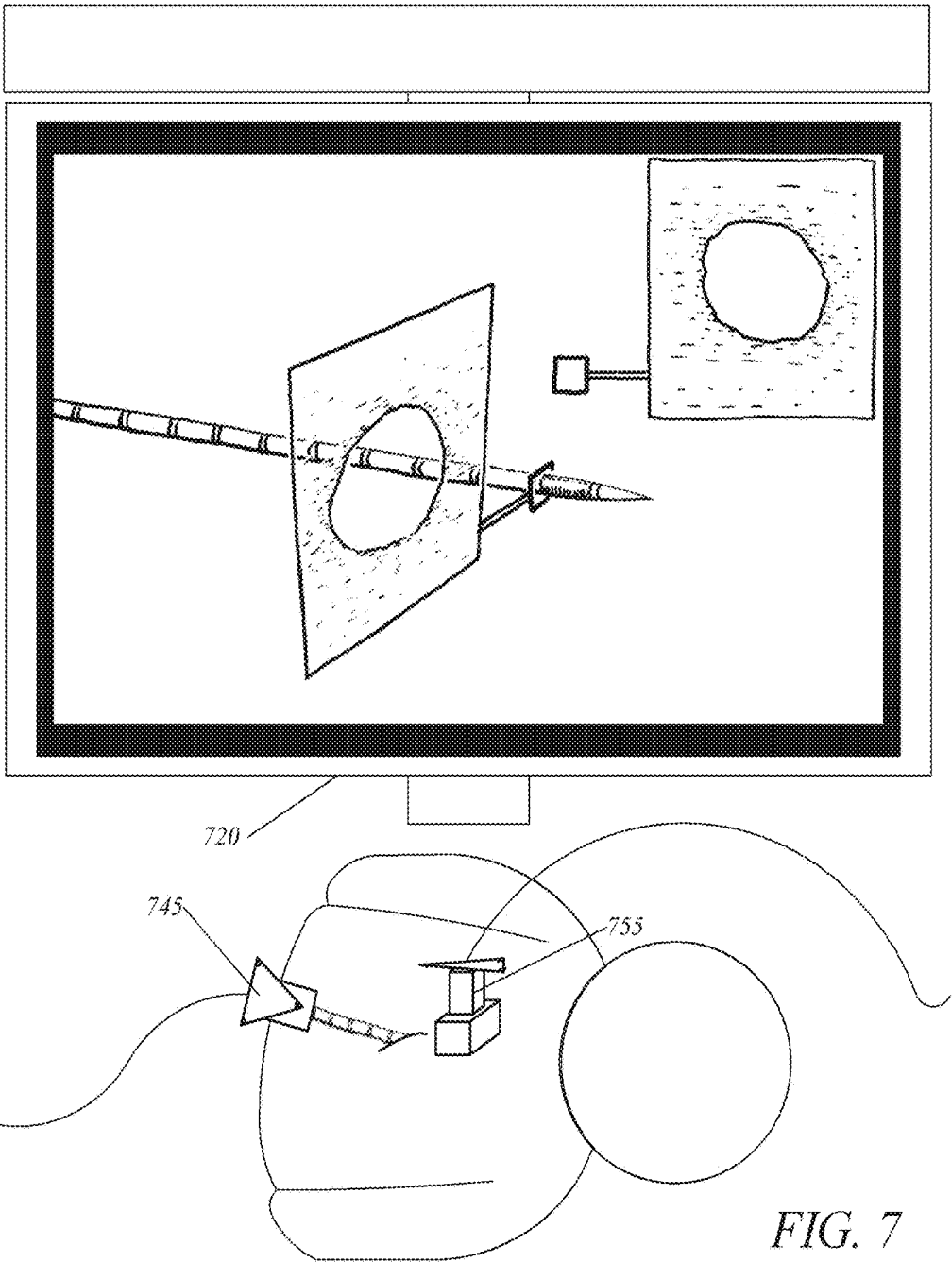

FIG. 6



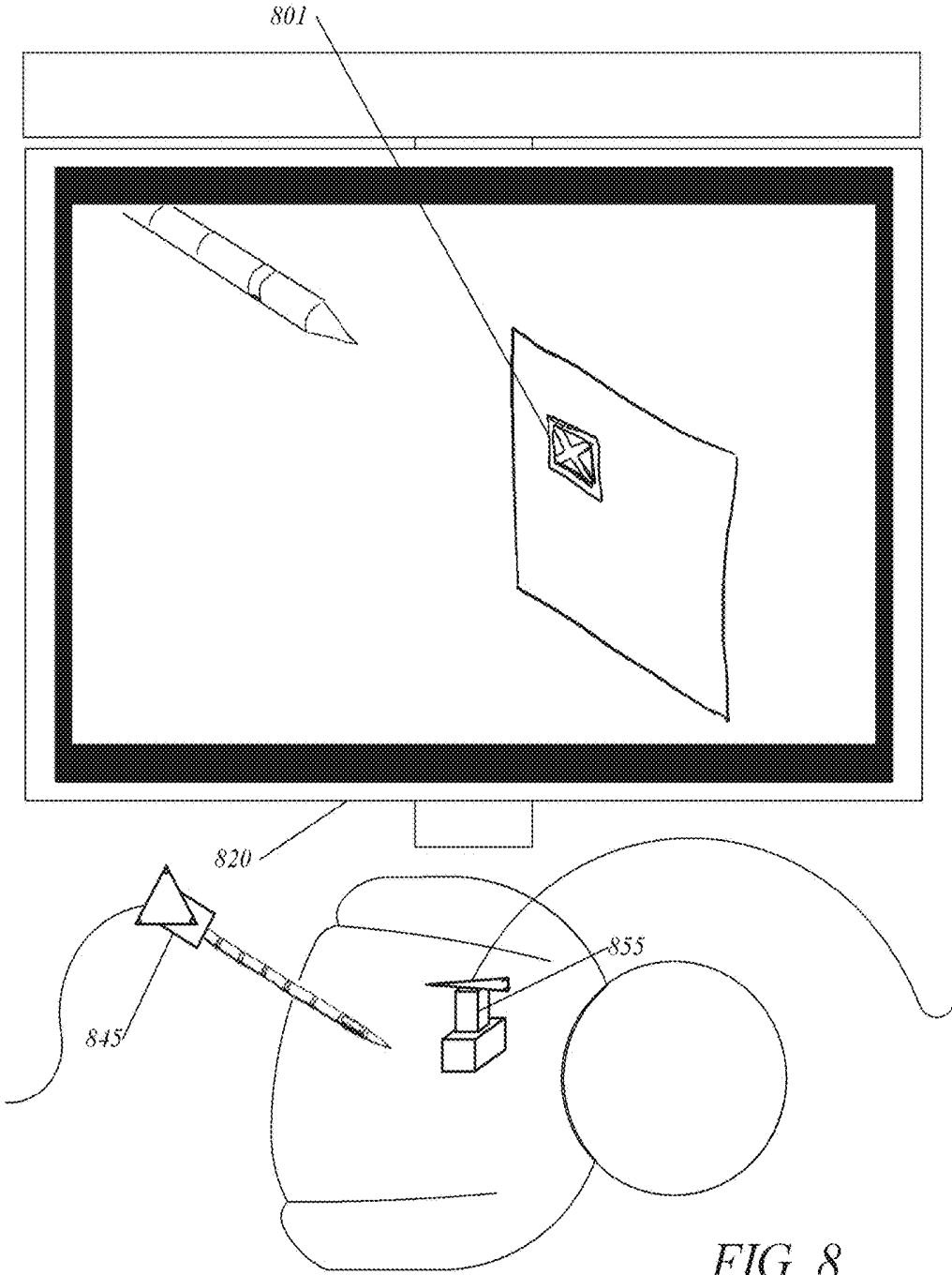
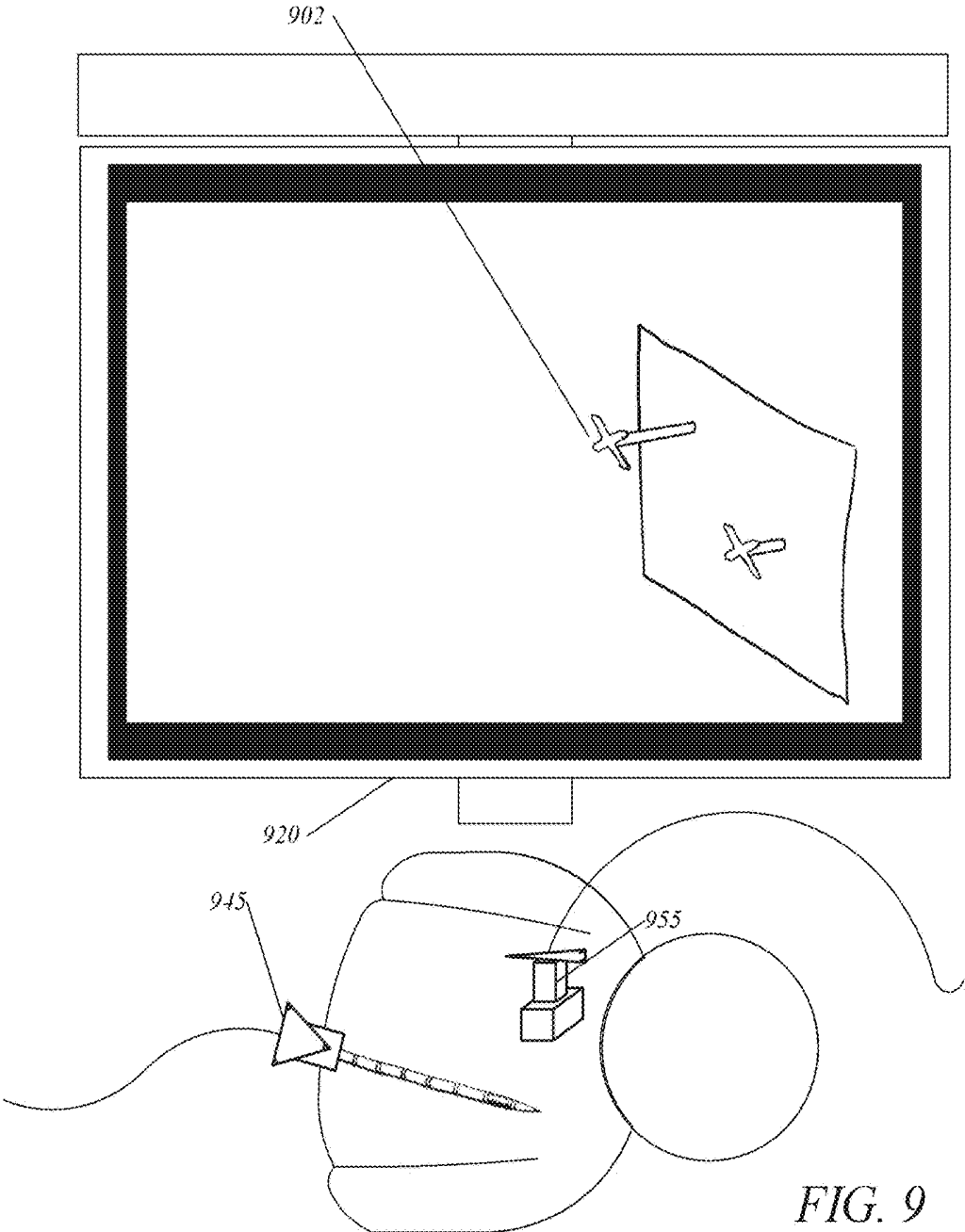
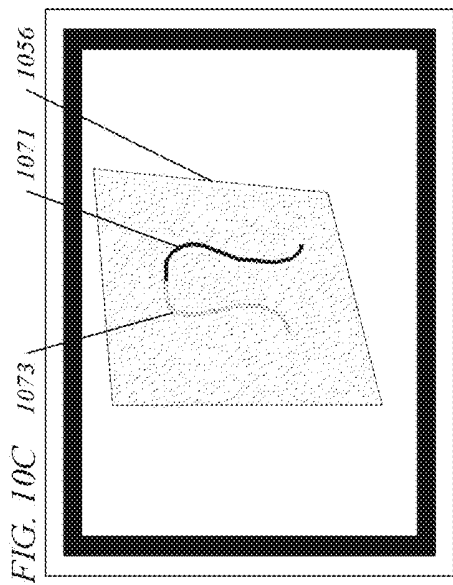
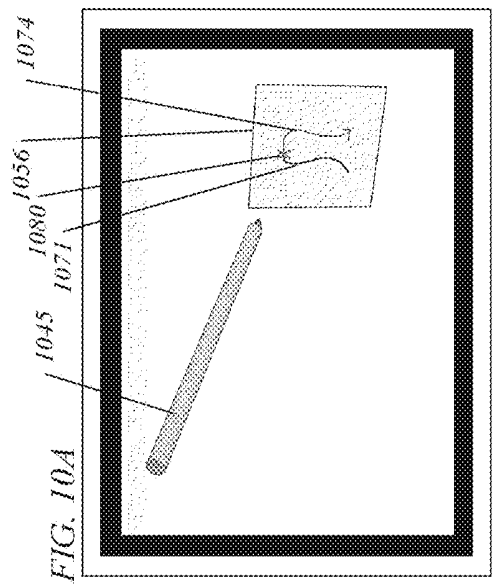
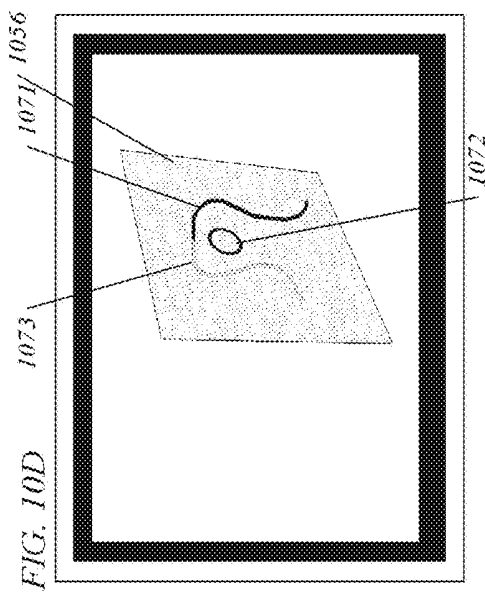
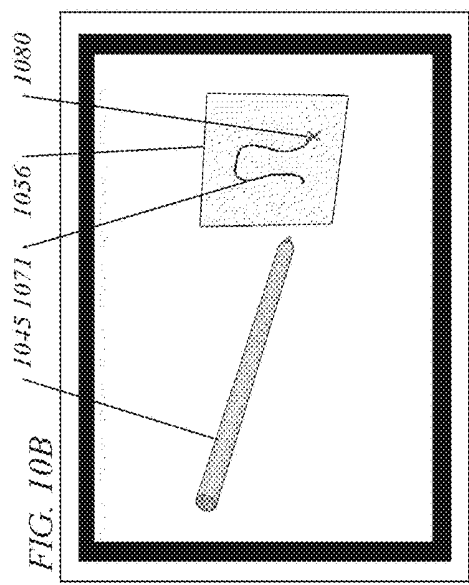

FIG. 8





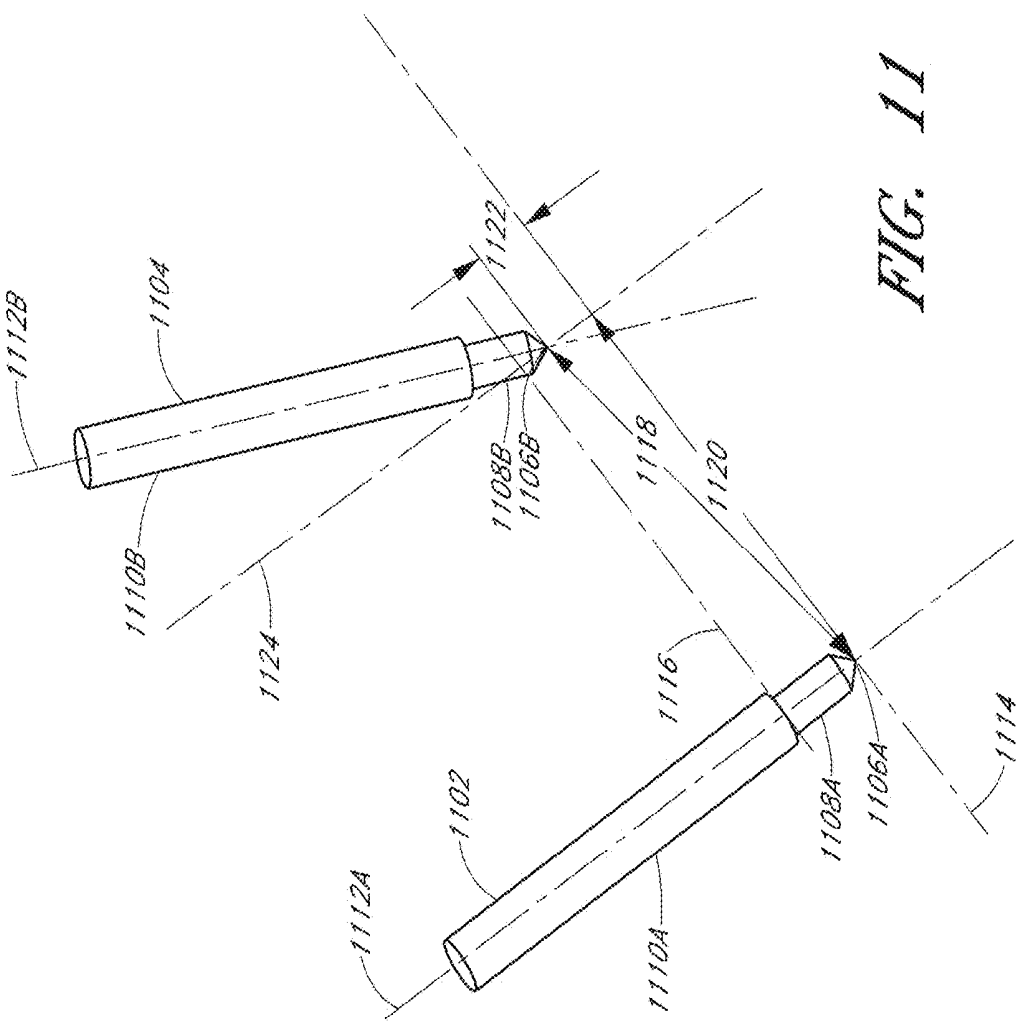

FIG. 11

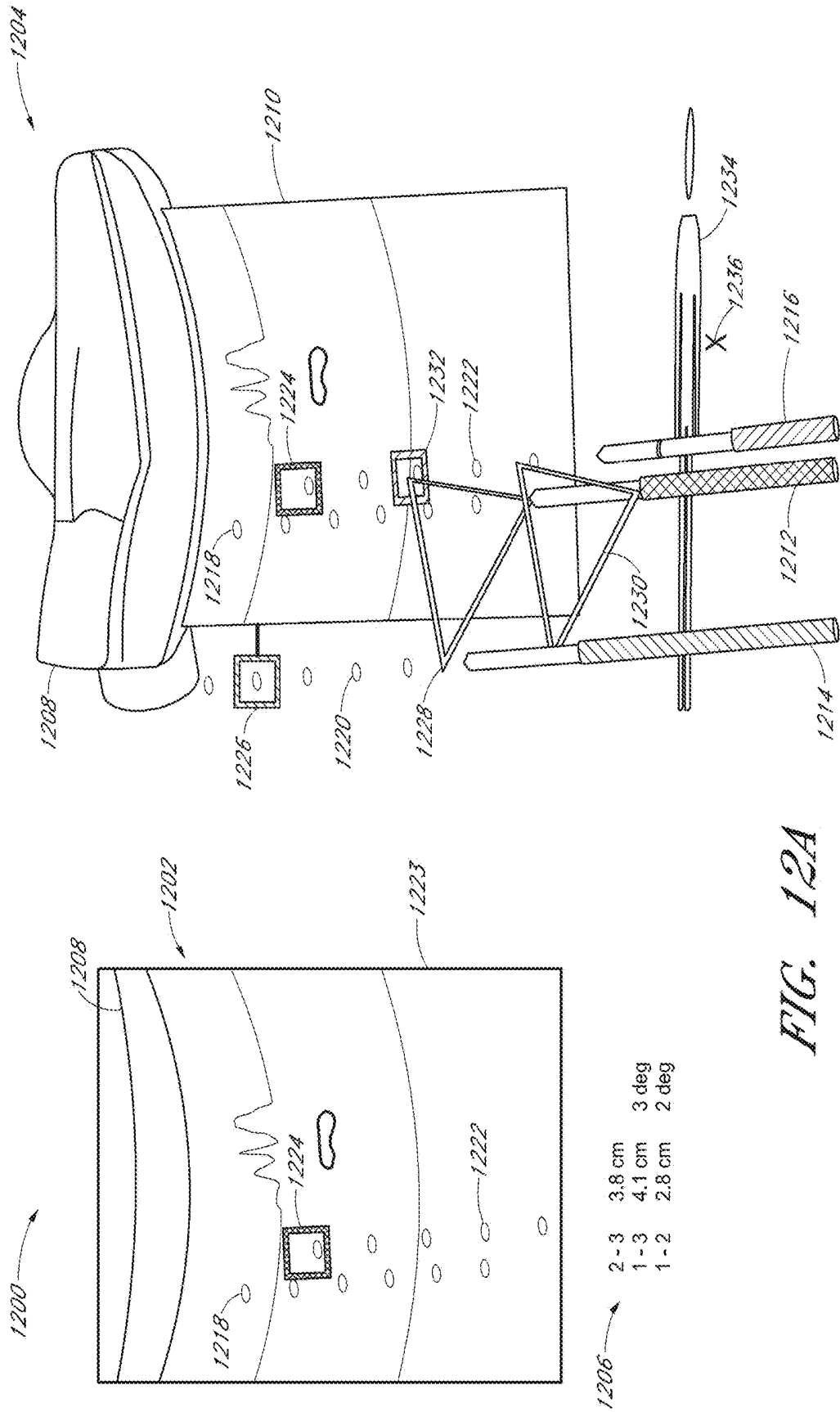
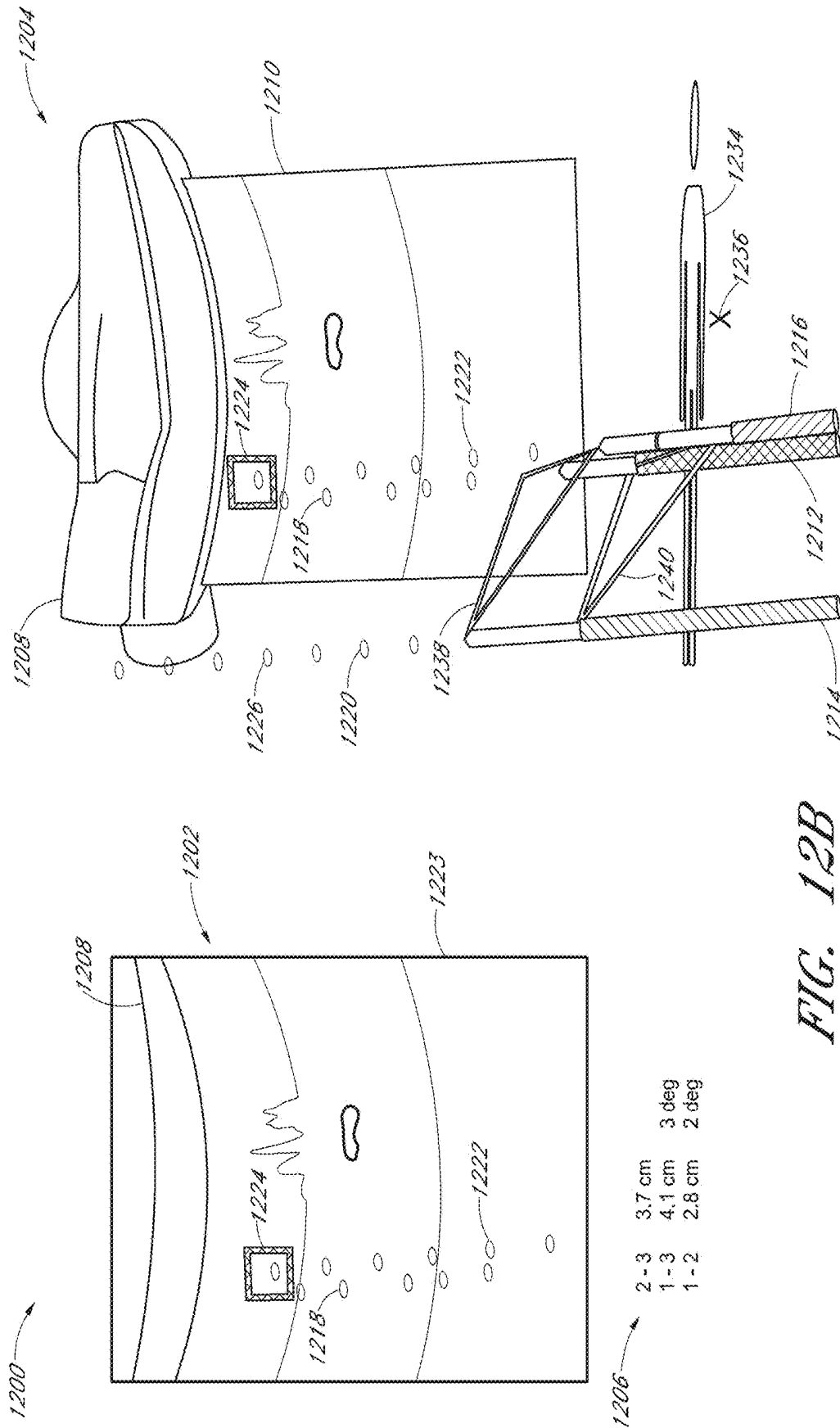

FIG. 12A



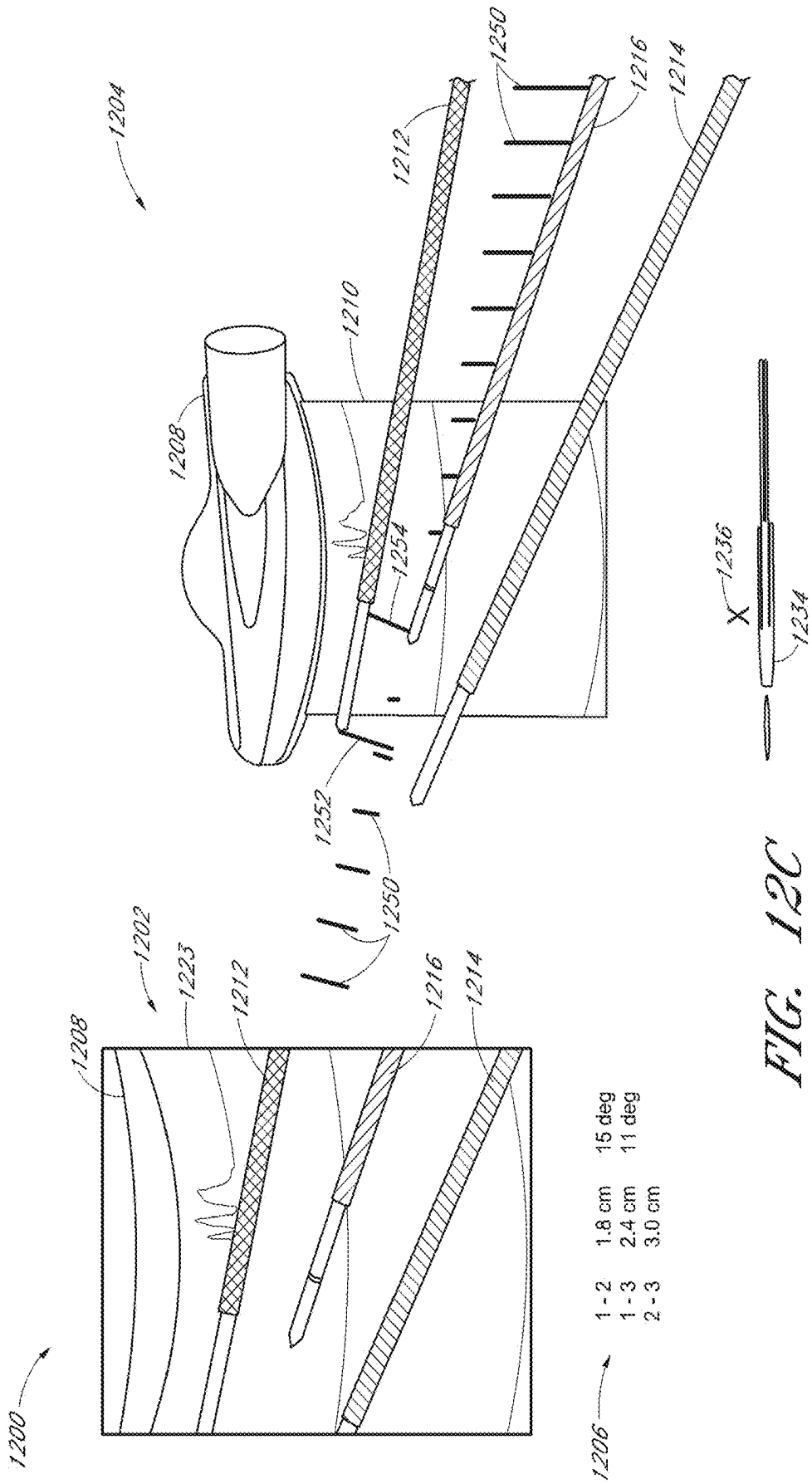

FIG. 12C

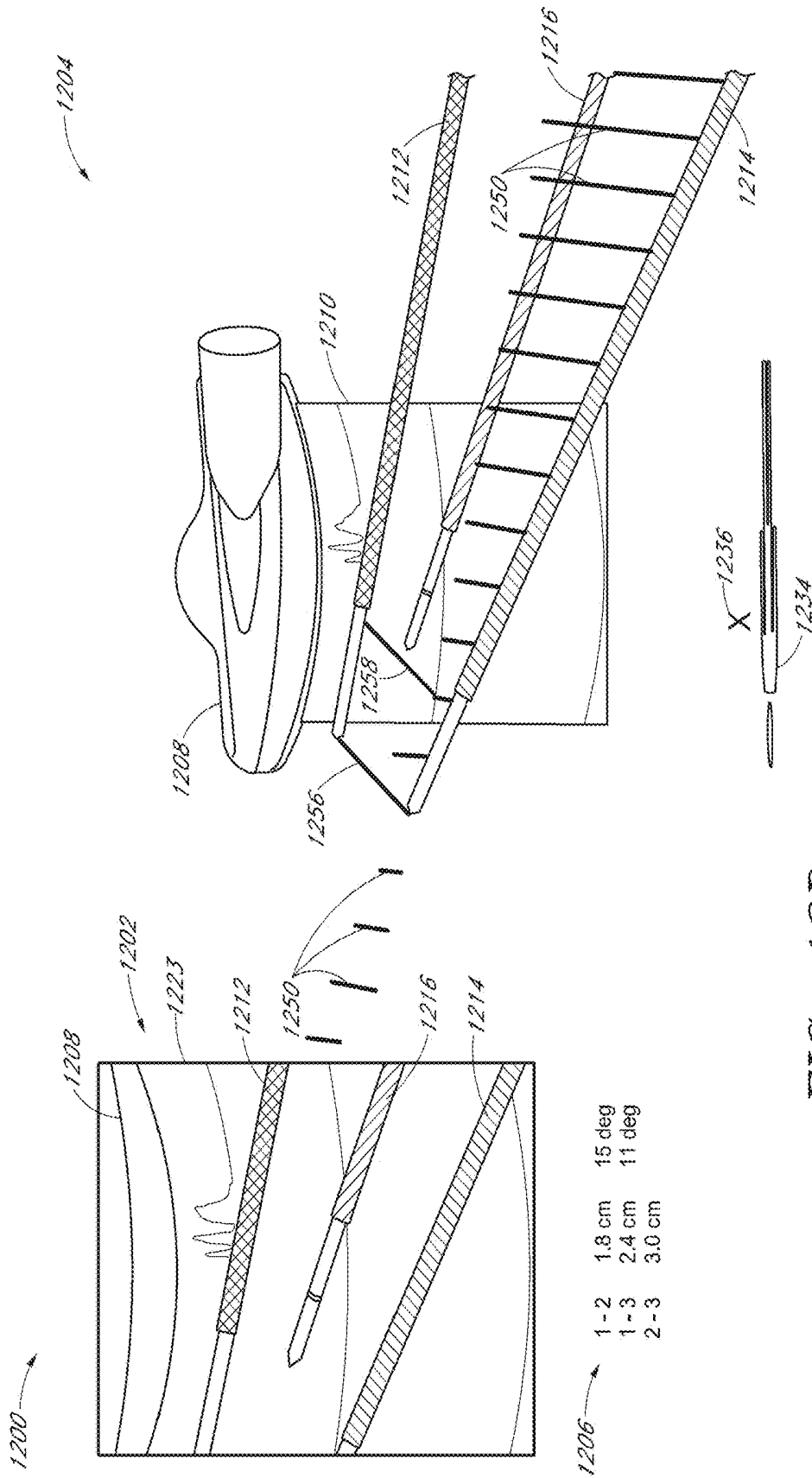

FIG. 12D

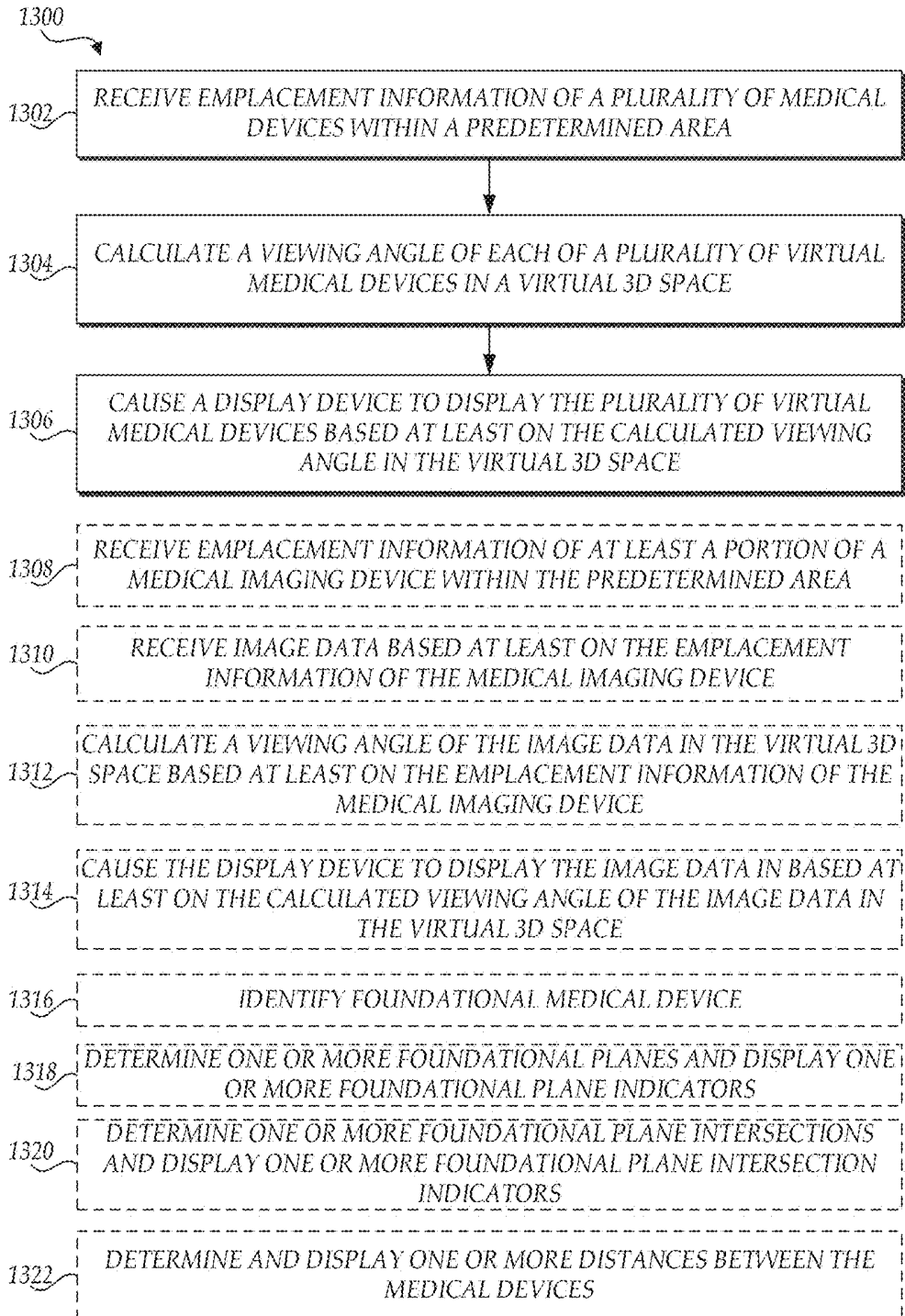

FIG. 13

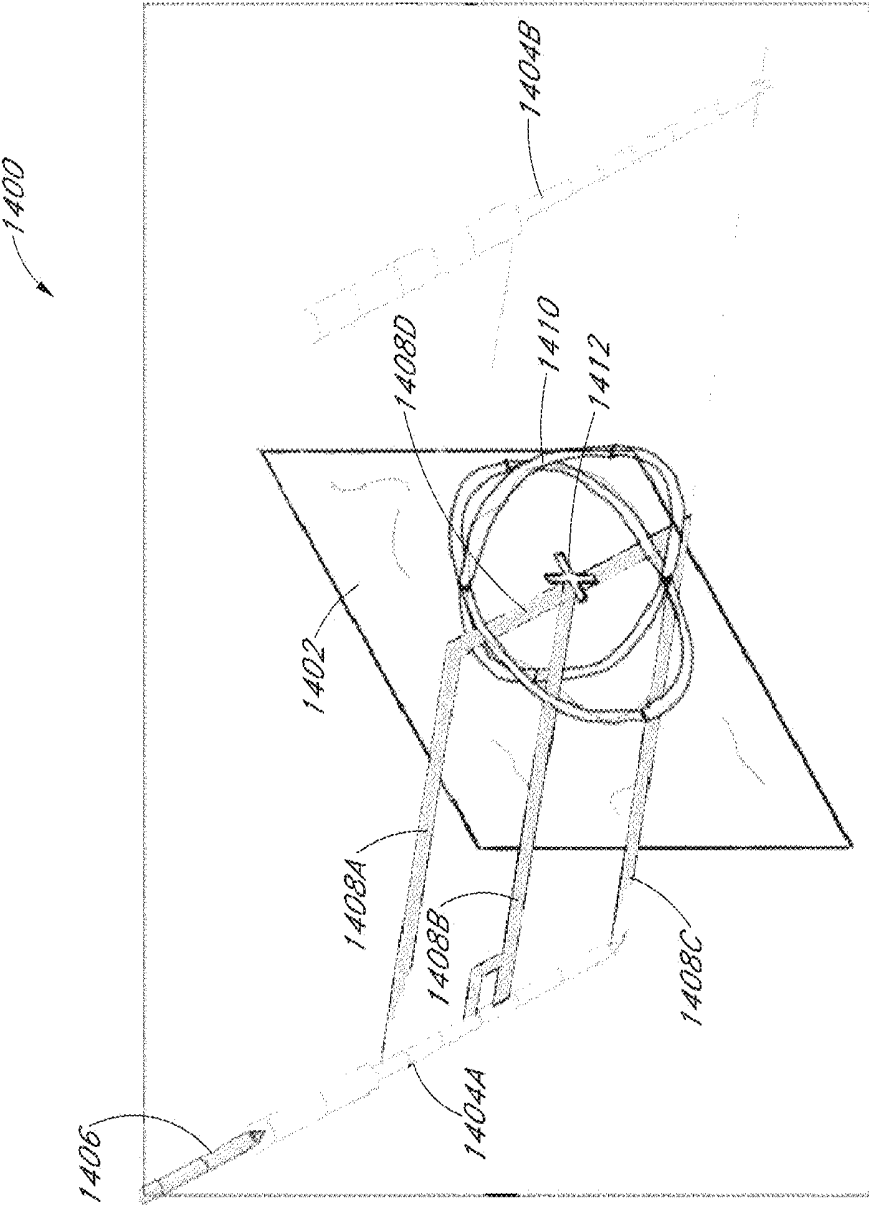

FIG. 14A

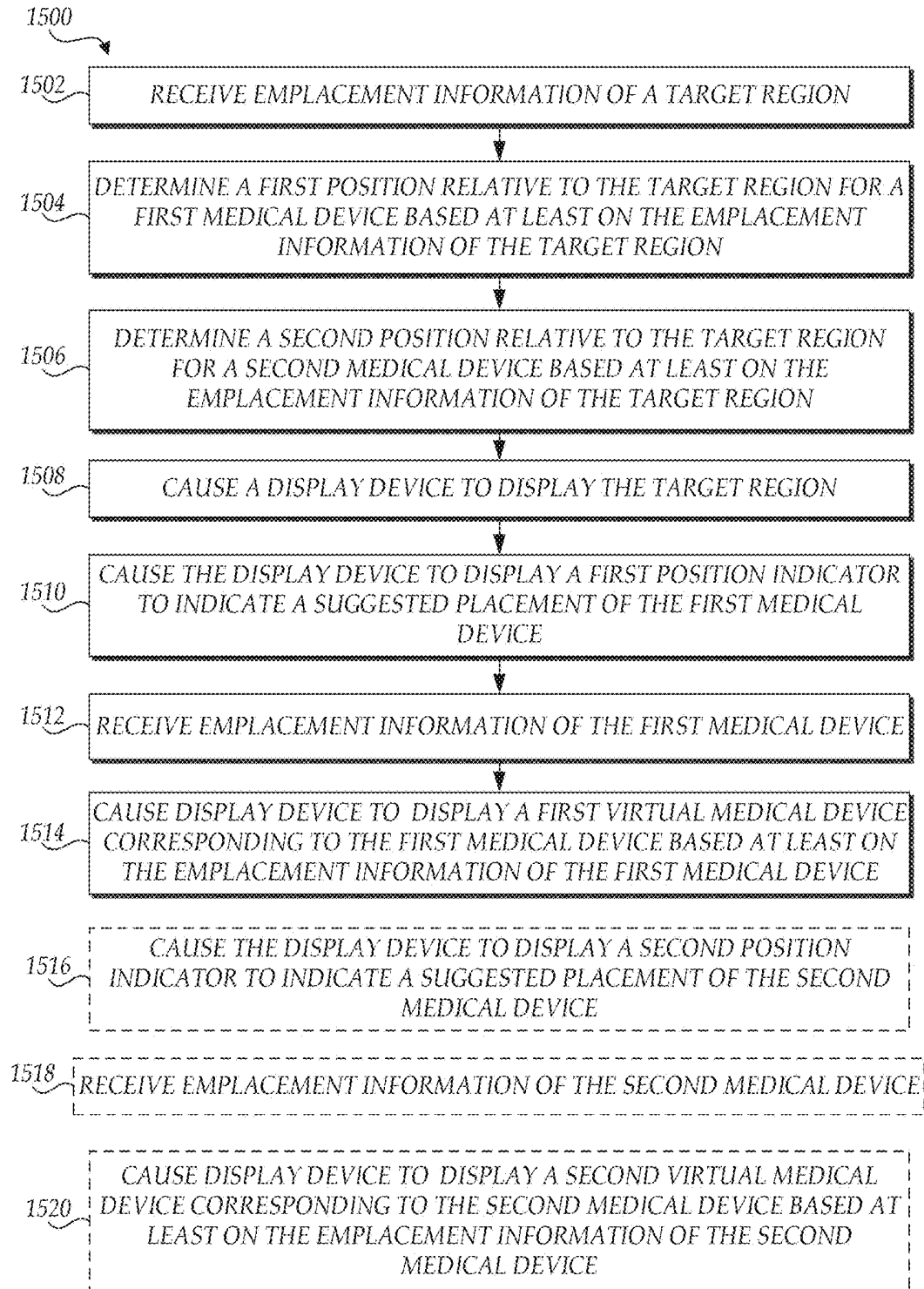

FIG. 15

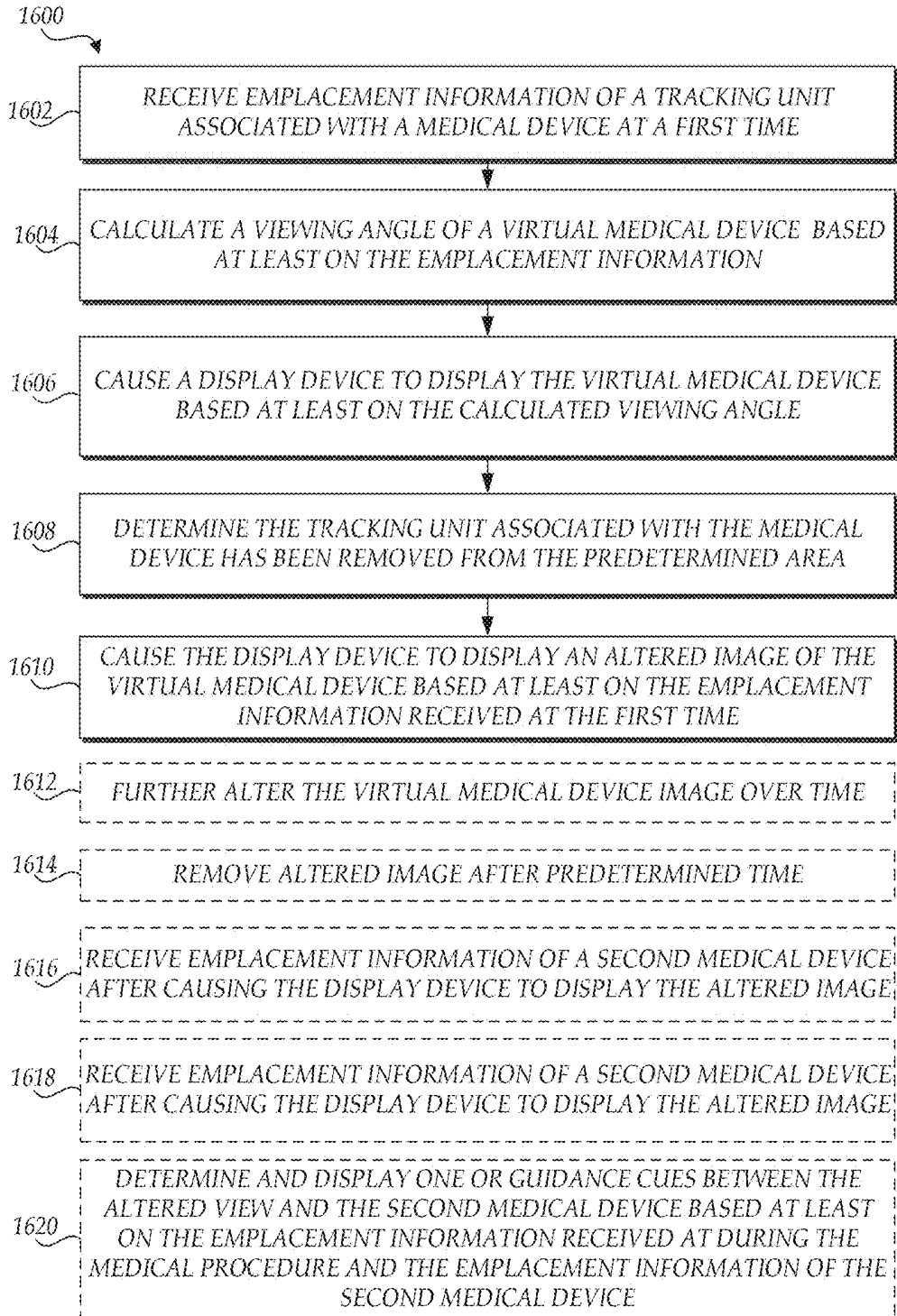

FIG. 16

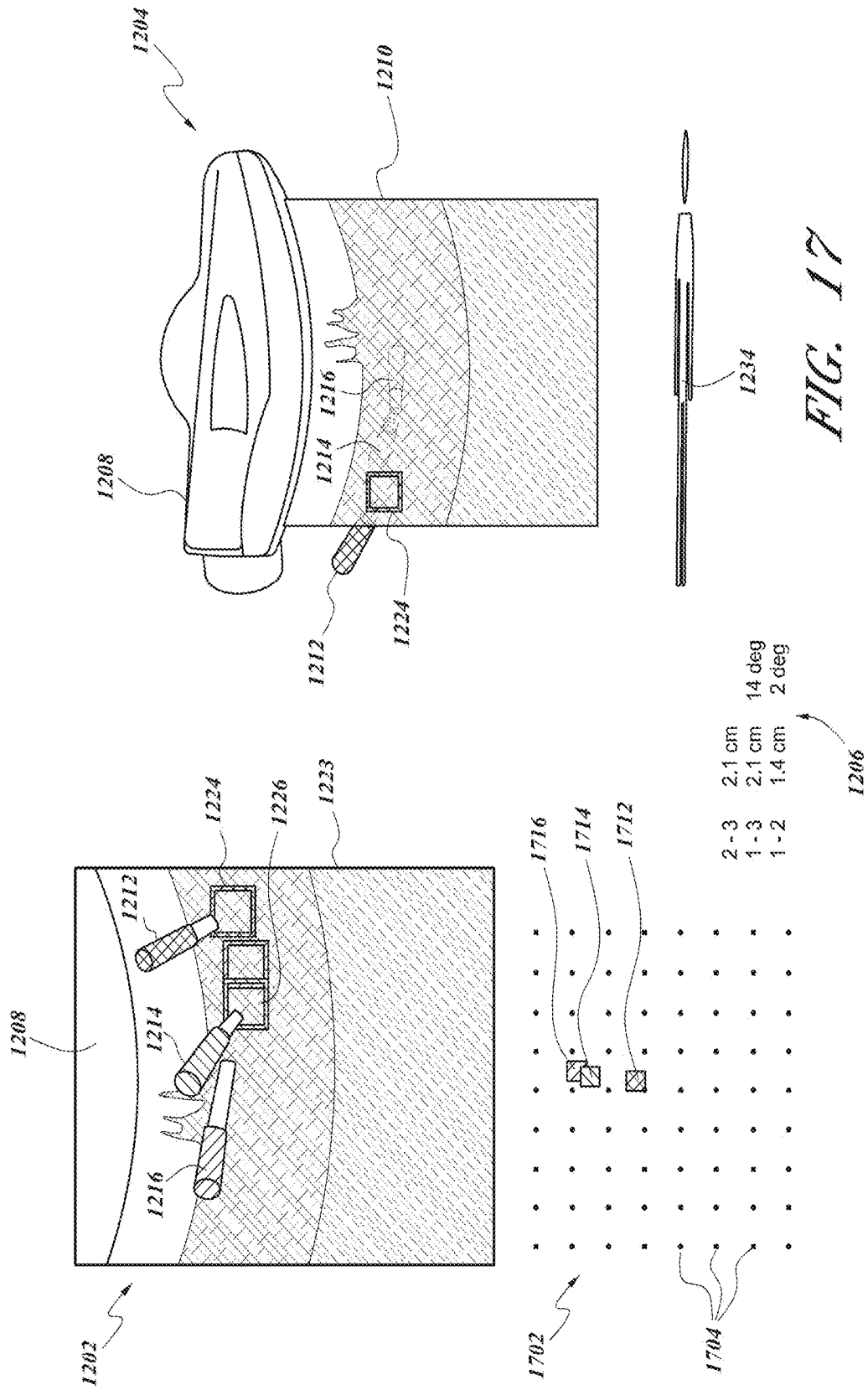
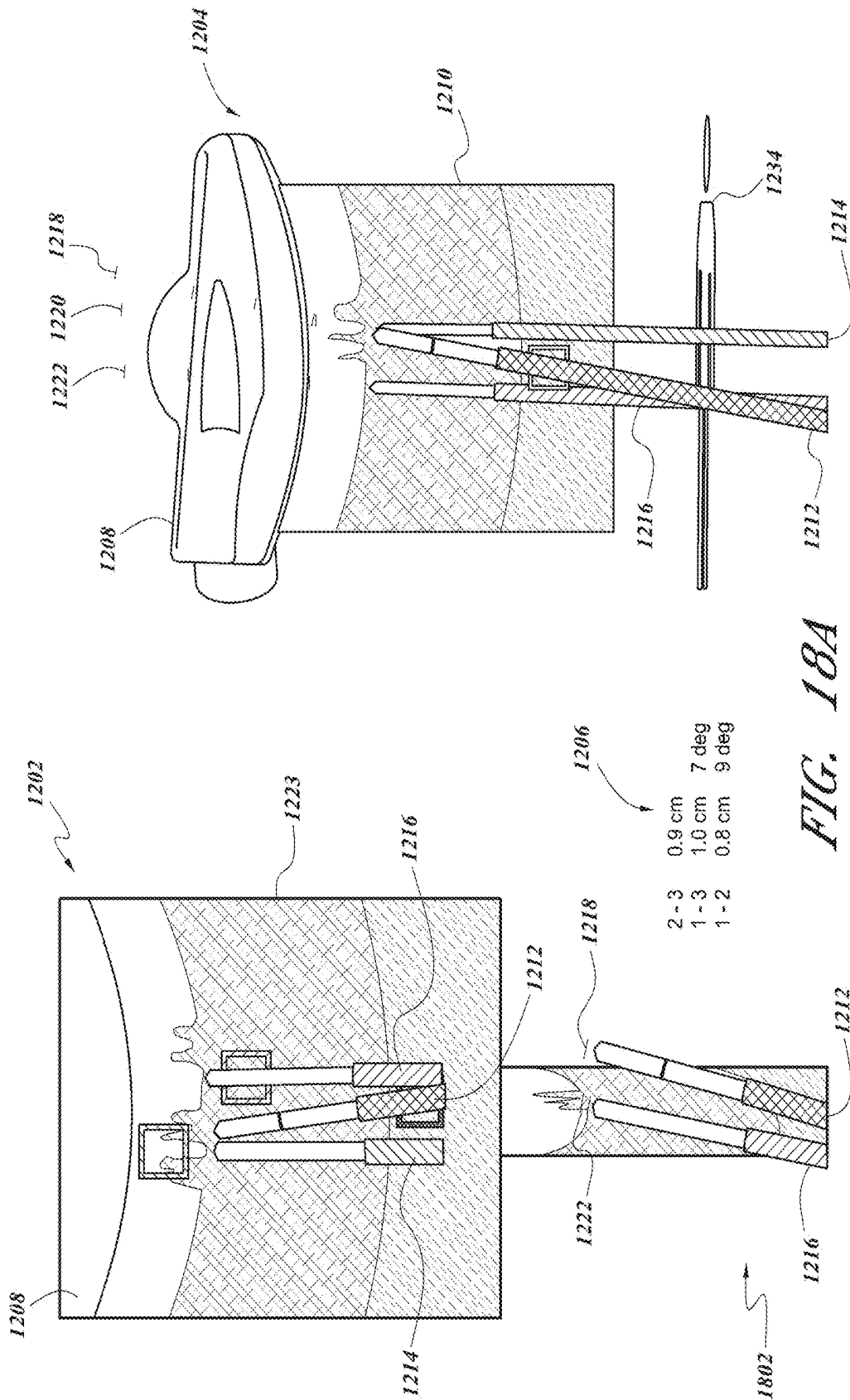

FIG. 17



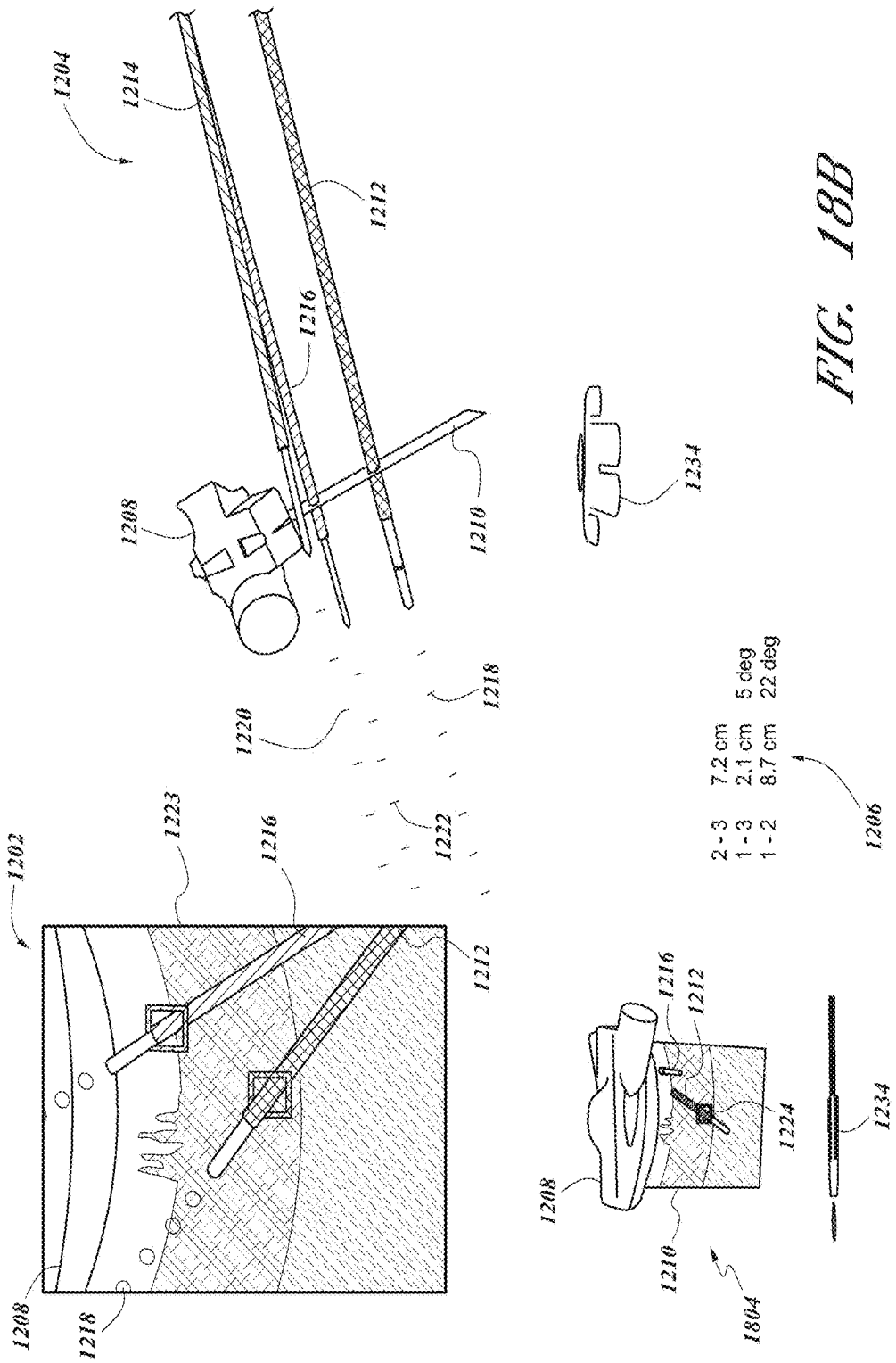

FIG. 18B

MULTIPLE MEDICAL DEVICE GUIDANCE

CROSS-REFERENCE TO RELATED APPLICATIONS

[0001] The present application is a continuation of U.S. application Ser. No. 14/190,725 filed Feb. 26, 2014, entitled MULTIPLE MEDICAL DEVICE GUIDANCE, which is a continuation of U.S. application Ser. No. 13/753,274, now issued U.S. Pat. No. 8,670,816, filed Jan. 29, 2013, entitled MULTIPLE MEDICAL DEVICE GUIDANCE, which claims priority benefit to U.S. Provisional Application Nos. 61/592,531, filed Jan. 30, 2012 and 61/736,789 filed Dec. 13, 2012, each of which is hereby incorporated herein by reference in its entirety.

TECHNICAL FIELD

[0002] The systems and methods disclosed herein relate generally to computer systems facilitating medical device guidance through tissue by a medical practitioner.

BACKGROUND

[0003] Various existing medical device systems, such as for ablation procedures, require a healthcare provider, such as a physician, to place controlled formations of medical devices into patient tissue. Examples of these systems include the RFA Medical InCircle™ System and the Angio-Dynamics NanoKnife™ system. Similarly, the Covidien Evident™ MWA System does not require, but supports, multi-medical device configurations. Many of these systems include a plastic guide piece to help the healthcare provider hold the medical devices in an acceptable spatial configuration (e.g. three medical devices held parallel, with shafts 2 cm apart).

[0004] Unfortunately, controlled placement of the medical devices often comes at the expense of operator flexibility and responsiveness. Accordingly, there is a need for a medical device guidance system which assists operators in placing medical devices, while permitting the operator to maintain an appropriate degree of hand flexibility.

BRIEF DESCRIPTION OF THE DRAWINGS

[0005] FIG. 1A illustrates a first exemplary system for image-guided medical procedures.

[0006] FIG. 1B illustrates a second exemplary system for image-guided medical procedures.

[0007] FIG. 2 illustrates a virtual rendering of an exemplary surgical instrument being displayed on a screen.

[0008] FIG. 3 illustrates a virtual rendering of an ablation volume of a surgical instrument being displayed on a screen.

[0009] FIG. 4 illustrates a virtual rendering of a trajectory and ablation volume of a surgical instrument being displayed on a screen.

[0010] FIG. 5 illustrates a virtual rendering of a surgical instrument and medical images displayed on a screen.

[0011] FIG. 6 illustrates a virtual rendering of a surgical instrument and guidance cues displayed on a screen.

[0012] FIG. 7 illustrates a virtual rendering of a surgical instrument and guidance cues displayed on a screen.

[0013] FIG. 8 illustrates a virtual rendering of a surgical instrument and guidance cues displayed on a screen.

[0014] FIG. 9 illustrates a virtual rendering of a surgical instrument and guidance cues displayed on a screen.

[0015] FIG. 10A-10D illustrates a virtual rendering of a surgical instrument and annotations displayed on a screen.

[0016] FIG. 11 is a diagram illustrating various features of multiple medical devices that can be tracked by the system.

[0017] FIGS. 12A-12D illustrate embodiments of displaying image guidance data for multiple medical devices.

[0018] FIG. 13 is a flow diagram illustrative of an embodiment of a routine implemented by the system to display a plurality of virtual medical devices.

[0019] FIG. 14A is a perspective view of an embodiment of a display for medical device placement guidance.

[0020] FIG. 14B illustrates the content on a display 1500 in certain embodiments depicting manipulation of a second medical device with respect to a target region.

[0021] FIG. 15 is a flow diagram illustrative of an embodiment of a routine implemented by the system to provide medical device placement guidance.

[0022] FIG. 16 is a flow diagram illustrative of an embodiment of a routine implemented by the system to display an altered image of a virtual medical device after a medical device has been removed from a predetermined area.

[0023] FIG. 17 is a diagram illustrative of an embodiment of a needle tip map.

[0024] FIG. 18A and 18B are diagrams illustrating embodiments of a rotated view.

DETAILED DESCRIPTION

System Overview

[0025] Implementations disclosed herein provide systems, methods and apparatus for generating images facilitating medical device insertion into tissue by an operator. Certain embodiments pertain to a free-hand medical device guidance system. The system can provide the healthcare provider full manual control over the medical device, while making the spatial relationships between the target, medical device and U/S image more intuitive via a visual display. Using this visual feedback, the operator can adjust the medical device's position, orientation, or trajectory. Particularly, the system can be used to facilitate multiple-medical device configurations. Certain of the contemplated embodiments can be used in conjunction with previous systems, such as U.S. patent application Ser. No. 13/014,587 and U.S. patent application Ser. No. 11/137,156, each of which is hereby incorporated by reference in its entirety.

[0026] In some embodiments, a user desires that the medical devices that are used together (e.g., used simultaneously for treating one tumor) are parallel to each other. In certain embodiments, the medical devices are arranged to be equally spaced from the center of the tumor. In some embodiments, a user desires that the tips of the medical devices be in the same plane, and all medical device shafts be perpendicular to that plane. In some embodiments, each medical device includes a single shaft-like electrode surrounded by a tube of electrically insulating material. The medical provider can expose some length of the electrode by sliding the insulating tube partially into the medical device's handle. In some embodiments, the length of the exposed electrode can be specified by the user (e.g. 0.5 cm-2 cm). In some embodiments, the length of the exposed electrodes can be the same for all medical devices. In certain embodiments, the healthcare provider exposes the electrode (by withdrawing the insulating sleeve) before placing the medical device into the patient. In some embodiments, the power generator

is provided the distances between the medical devices, and the length of the exposed electrodes. In some embodiments, the medical devices can move continuously, even after the healthcare provider has placed them into the proper position in the patient's tissue because of patient motion from breathing, manual manipulation, etc. In some embodiments, the medical devices are not parallel to an image plane.

[0027] The system can aid the healthcare provider in placing the medical devices. In some embodiments, the system improves the healthcare provider's ability to place the medical devices level with each other (e.g., tips are co-planar) and parallel with each other. The system can also aid the healthcare provider in determining the number of medical devices to be used and what their optimal positions are, including: distance from tumor's center; distance from tumor's extent or boundary; medical device depth; spacing between medical devices; angle between medical devices; exposure of the deployable electrodes (or optimal retraction of the electrode's insulation), etc.

[0028] The system can also help the healthcare provider determine what healthy tissues are in an ablation zone volume (by displaying the predicted ablation zone of the multi-medical device configuration). The system can help the healthcare provider place the medical devices in the above determined (planned) configuration. The system can help the healthcare provider understand how the current configuration (i.e. the way the medical devices are currently placed) differs from the optimal, acceptable or pre-planned configurations. The system can output the distance between medical devices to the power generator, so that the ablation time, the ablation power and other ablation parameters can be automatically computed by the ablation generator. The system can be used for treatment of tumors, fibroids or cysts, with bipolar radiofrequency medical device ablation, multiple microwave medical devices, electroporation, and/or electrochemotherapy systems. It can also be used for nerve or muscle stimulation or sensing (electrodes in the spine, brain). The system can be used during open surgery, laparoscopic surgery, endoscopic procedures, biopsies, and/or interventional radiology procedures.

[0029] The system can be used in conjunction with live intraoperative ultrasound (U/S), pre-operative CT, or any cross-sectional medical imaging modality (e.g. MRI, OCT, etc.). In addition, the system can use a variety of techniques to determine each medical device's position and orientation. For example, the system can use the NDI Aurora magnetic system, NDI Polaris optical system, etc. In some embodiments, a position sensor can be embedded inside, or affixed to the outside of each medical device, at the tip, along the shaft, or on the handle. Sensors can be built into the medical devices or attached after manufacturing, before use. Each medical device can have its own sensor, which continually reports position and orientation, or a single sensor can be used for all the medical devices. In embodiments where one sensor is used, the healthcare provider can attach the sensor to the particular medical device that she is intentionally repositioning, and then, once she has placed that medical device, she would remove the sensor and attach it to the next medical device she is repositioning. In some embodiments, the medical devices, U/S probe and/or laparoscope can be manipulated by the healthcare provider. In certain embodiments, the system can be used with a robotic manipulator, where the robot controls the medical devices, U/S probe and/or laparoscope.

[0030] In some embodiments, the handles of medical devices can have push-button switches, to allow the user to select a medical device, indicate a tissue target, etc. The handle can also have an indicator light to indicate to the users which medical device is selected. Finally, the handle can have an encoder to detect how much length of electrode has been exposed by the user, and report this information to the guidance system and therapeutic generator

Image Guidance Systems

[0031] FIG. 1A illustrates a first exemplary system for image management in image-guided medical procedures. FIG. 1B illustrates a second exemplary system for image management in image-guided medical procedures. In many respects the embodiments illustrated by FIG. 1A and 1B are similar and use similar numbering. Where the two are different, those differences are noted. The differences between the two figures can include that, in FIG. 1A, two position sensing units **110** and **140** are shown, whereas in FIG. 1B, only a single position sensing unit **110** is shown.

[0032] In some embodiments, position sensing units **110** and **140** can track surgical instruments, also referred to herein as medical devices, within a tracking area and provide data to the image guidance unit. The medical devices can include invasive medical devices, biopsy needles, ablation needles, surgical needles, nerve-block needles, or other needles, electrocautery device, catheters, stents, laparoscopic cameras, or other instruments that enter a part of the body, and non-invasive medical devices that do not enter the body, such as ultrasound transducers. The medical devices can also include medical imaging devices that provide or aid in the selection of medical images for display. In some embodiments, the medical imaging device can be any device that is used to select a particular medical image for display. The medical imaging devices can include invasive medical devices, such as laparoscopic cameras, and non-invasive medical devices, such as ultrasound transducers.

[0033] Although only two surgical instruments **145** and **155** are shown in FIGS. 1A and 1B, it will be understood that additional surgical instruments can be tracked and associated data can be provided to the image guidance unit **130**. The image guidance unit **130** can process or combine the data and show image guidance data on display **120**. This image guidance data can be used by a healthcare provider to guide a procedure and improve care. There are numerous other possible embodiments of system **100**. For example, many of the depicted modules can be joined together to form a single module and can be implemented in a single computer or machine. Further, position sensing units **110** and **140** can be combined and track all relevant surgical instruments **145** and **155**, as discussed in more detail below and exemplified in FIG. 1B. Additional imaging units **150** can be included, and combined imaging data from the multiple imaging units **150** can be processed by image guidance unit **130** and shown on display unit **120**. Additionally, two or more surgical systems **149** can also be included.

[0034] Information about and from multiple surgical systems **149** and attached surgical instruments **145** (and additional surgical instruments not shown) can be processed by image guidance unit **130** and shown on display **120**. These and other possible embodiments are discussed in more detail below. Imaging unit **150** can be coupled to image guidance unit **130**. In some embodiments, imaging unit **150** can be coupled to a second display unit (not shown). The second

display unit can display imaging data from imaging unit 150. The imaging data displayed on display unit 120 and displayed on second display unit can be the same or different. In some embodiments, the imaging unit 150 is an ultrasound machine 150, the movable imaging device 155 is an ultrasound transducer 155 or ultrasound probe 155, and the second display unit is a display associated with the ultrasound machine 150 that displays the ultrasound images from the ultrasound machine 150. In some embodiments, a movable imaging unit 155 can be connected to image guidance unit 130. The movable imaging unit 155 can be useful for allowing a user to indicate what portions of a first set of imaging data are to be displayed. For example, the movable imaging unit 155 can be an ultrasound transducer 155, a needle or other medical device, for example, and can be used by a user to indicate what portions of imaging data, such as a pre-operative CT scan, to show on a display unit 120 as image 125. Further, in some embodiments, there can be a third set of pre-operative imaging data that can be displayed with the first set of imaging data.

[0035] In some embodiments, system 100 comprises a first position sensing unit 110, a display unit 120, and second position sensing unit 140 (if it is included) all coupled to image guidance unit 130. In some embodiments, first position sensing unit 110, display unit 120, and image guidance unit 130 are all physically connected to stand 170. Image guidance unit 130 can be used to produce images 125 that are displayed on display unit 120. The images 125 produced on display unit 120 by the image guidance unit 130 can be determined based on ultrasound or other visual images from the first surgical instrument 145 and second surgical instrument 155.

[0036] For example, if the first surgical instrument 145 is an ablation needle 145 and the second surgical instrument 155 is an ultrasound probe 155, then images 125 produced on display 120 can include the images, or video, from the ultrasound probe 155 combined with graphics, such as projected medical device drive or projected ablation volume, determined based on the emplacement of ablation needle 145. If the first surgical instrument 145 is an ultrasound probe 145 and the second surgical instrument 155 is a laparoscopic camera 155, then images 125 produced on display 120 can include the video from the laparoscopic camera 155 combined with ultrasound data superimposed on the laparoscopic image. More surgical instruments can be added to the system. For example, the system can include an ultrasound probe, ablation needle, laparoscopic camera, cauterizer, scalpel and/or any other surgical instrument or medical device. The system can also process and/or display collected data, such as preoperative CT scans, X-Rays, MRIs, laser scanned 3D surfaces etc.

[0037] The term “emplacement” and the term “pose” as used herein are broad terms encompassing their plain and ordinary meanings and may refer to, without limitation, position, orientation, the combination of position and orientation, or any other appropriate location information. In some embodiments, the imaging data obtained from one or both of surgical instruments 145 and 155 can include other modalities such as a CT scan, MRI, open-magnet MRI, optical coherence tomography (“OCT”), positron emission tomography (“PET”) scans, fluoroscopy, ultrasound, or other preoperative, or intraoperative 2D or 3D anatomical imaging data. In some embodiments, surgical instruments 145 and 155 can also be scalpels, implantable hardware, or

any other device used in surgery. Any appropriate surgical system 149 or imaging unit 150 can be attached to the corresponding medical instruments 145 and 155.

[0038] As noted above, images 125 produced can also be generated based on live, intraoperative, or real-time data obtained using the second surgical instrument 155, which is coupled to second imaging unit 150. The term “real time” as used herein is a broad term and has its ordinary and customary meaning, including without limitation instantaneously or nearly instantaneously. The use of the term real time can also mean that actions are performed or data is obtained with the intention to be used immediately, upon the next cycle of a system or control loop, or any other appropriate meaning. Additionally, as used herein, real-time data can be data that is obtained at a frequency that would allow a healthcare provider to meaningfully interact with the data during surgery. For example, in some embodiments, real-time data can be a medical image of a patient that is updated one time per second. In some embodiments, real-time data can be ultrasound data that is updated multiple times per second.

[0039] Second surgical instrument 155 can be coupled to second position sensing unit 140. Second position sensing unit 140 can be part of imaging unit 150 or it can be separate. Second position sensing unit 140 can be used to determine the emplacement of second surgical instrument 155. In some embodiments, first and/or second position sensing units 110 and/or 140 can be magnetic trackers and magnetic can be coils coupled to surgical instruments 145 and/or 155. In some embodiments, first and/or second position sensing units 110 and/or 140 can be optical trackers and visually-detectable fiducials can be coupled to surgical instruments 145 and/or 155.

[0040] Images 125 can be produced based on intraoperative or real-time data obtained using first surgical instrument 145, which is coupled to first surgical system 149. In FIGS. 1A and 1B, first surgical system 149 is shown as coupled to image guidance unit 130. The coupling between the first surgical system 149 and image guidance unit 130 may not be present in all embodiments. In some embodiments, the coupling between first surgical system 149 and image guidance unit 130 can be included where information about first surgical instrument 145 available to first surgical system 149 is useful for the processing performed by image guidance unit 130. For example, in some embodiments, the first surgical instrument 145 is an ablation needle 145 and first surgical system 149 is an ablation system 149. In some embodiments, it can be useful to send a signal about the relative strength of planned ablation from ablation system 149 to image guidance unit 130 in order that image guidance unit 130 can show a predicted ablation volume. In other embodiments, the first surgical system 149 is not coupled to image guidance unit 130. Example embodiments including images and graphics that can be displayed are included below.

[0041] In some embodiments, the first position sensing unit 110 tracks the emplacement of first surgical device 145. First position sensing unit 110 can be an optical tracker 110 and first surgical device 145 can have optical fiducials attached thereto. The emplacement of optical fiducials can be detected by first position sensing unit 110, and, therefrom, the emplacement of first surgical device 145 can be determined.

[0042] In various embodiments, as depicted in FIG. 1B, a single position sensing unit **110** can track both first medical device **145** and second medical device **155**. In FIG. 1B, in some embodiments, position sensing unit **110** is a magnetic tracker and is mounted below a surgical table **180**. Such an arrangement can be useful when the tracking volume of the position sensing unit **110** is dependent on the location of the position sensing unit, as with many magnetic trackers. Magnetic tracking coils can be mounted in or on the medical devices **145** and **155**.

[0043] In some embodiments, either or both of the first position sensing unit **110** and the second position sensing unit **140** can be an Ascension Flock of Birds, Nest of Birds, driveBAY, medSAFE, trakSTAR, miniBiRD, MotionSTAR, pciBiRD, or Calypso 2D Localization System and tracking units attached to the first and/or second medical devices **145** and **155** can be magnetic tracking coils. The term “tracking unit,” as used herein, is a broad term encompassing its plain and ordinary meaning and includes without limitation all types of magnetic coils or other magnetic field sensing devices for use with magnetic trackers, fiducials or other optically detectable markers for use with optical trackers, such as those discussed above and below. In some embodiments, the tracking units can be implemented using optical position sensing devices, such as the HiBall tracking system and the first and second position sensing units **110** and **140** can form part of the HiBall tracking system. Tracking units can also include a GPS device or signal emitting device that allows for tracking of the position and, optionally, orientation of the tracking unit. In some embodiments, a signal emitting device might include a radio-frequency identifier (RFID). In such embodiments, the first and/or second position sensing unit **110** and **140** can use the GPS coordinates of the tracking units or can, for example, triangulate the radio frequency signal being emitted by the RFID associated with tracking units. The tracking systems can also include one or more 3D mice.

[0044] In some embodiments, either or both of the first position sensing unit **110** and the second position sensing unit **140** can be an electromagnetic measurement system (e.g., NDI Aurora system) using sensor coils for tracking units attached to the first and/or second surgical devices **145** and **155**. In some embodiments, either or both of the first position sensing unit **110** and the second position sensing unit **140** can be an optical 3D tracking system using fiducials. Such optical 3D tracking systems can include the NDI Polaris Spectra, Vicra, Certus, PhaseSpace IMPULSE, Vicon MX, InterSense IS-900, NaturalPoint OptiTrack, Polhemus FastTrak, IsoTrak, or Claron MiconTracker2. In some embodiments, either or both of position sensing units **110** and **140** can each be an inertial 3D tracking system comprising a compass, accelerometer, tilt sensor and/or gyro, such as the InterSense InertiaCube or the Nintendo Wii controller. In some embodiments, either or both of position sensing units **110** and **140** can be attached to or affixed on the corresponding surgical device **145** and **155**. In some embodiments, the position sensing units, **110** and **140**, can include sensing devices such as the HiB all tracking system, a GPS device, or signal emitting device that would allow for tracking of the position and, optionally, orientation of the tracking unit. In some embodiments, a position sensing unit **110** or **140** can be affixed to either or both of the surgical devices **145** and **155**. The surgical devices **145** or **155** can be tracked by the position sensing units **110** or **140**. A room

coordinate system reference, such as the display **120** can also be tracked by the position sensing unit **110** or **140** in order to determine the emplacements of the surgical devices **145** and **155** with respect to the room coordinate system. Devices **145** and **155** can also include or have coupled thereto one or more accelerometers, which can be used to estimate movement, position, and location of the devices.

[0045] In some embodiments, the display unit **120** displays 3D images to a user, such as a healthcare provider. Stereoscopic 3D displays separate the imagery shown to each of the user's eyes. This can be accomplished by a stereoscopic display, a lenticular auto-stereoscopic display, or any other appropriate type of display. The display **120** can be an alternating row or alternating column display. Example alternating row displays include the Miracube G240S, as well as Zalman Trimon Monitors. Alternating column displays include devices manufactured by Sharp, as well as many “auto-stereoscopic” displays (e.g., Philips). Display **120** can also be a cathode ray tube. Cathode Ray Tube (CRT) based devices, can use temporal sequencing, showing imagery for the left and right eye in temporal sequential alternation. This method can also be used projection-based devices, as well as by liquid crystal display (LCD) devices, light emitting diode (LED) devices, and/or organic LED (OLED) devices.

[0046] In certain embodiments, a user can wear a head mounted display in order to receive 3D images from the image guidance unit **130**. In such embodiments, a separate display, such as the pictured display unit **120**, can be omitted. The 3D graphics can be produced using underlying data models, stored in the image guidance unit **130** and projected onto one or more 2D planes in order to create left and right eye images for a head mount, lenticular, or other 3D display. The underlying 3D model can be updated based on the relative emplacements of the various devices **145** and **155**, as determined by the position sensing unit(s), and/or based on new data associated with the devices **145** and **155**. For example, if the second medical device **155** is an ultrasound probe, then the underlying data model can be updated to reflect the most recent ultrasound image. If the first medical device **145** is an ablation needle, then the underlying model can be updated to reflect any changes related to the needle, such as power or duration information. Any appropriate 3D graphics processing can be used for rendering including processing based on OpenGL, Direct3D, Java 3D, etc. Whole, partial, or modified 3D graphics packages can also be used, such packages including 3DS Max, SolidWorks, Maya, Form Z, Cybermotion 3D, VTK, Slicer, or any others. In some embodiments, various parts of the needed rendering can occur on traditional or specialized graphics hardware. The rendering can also occur on the general CPU, on programmable hardware, on a separate processor, be distributed over multiple processors, over multiple dedicated graphics cards, or using any other appropriate combination of hardware or technique.

[0047] One or more modules, units, devices, or elements of various embodiments can be packaged and/or distributed as part of a kit. For example, in one embodiment, an ablation needle, tracking elements, 3D viewing glasses, and/or a portion of an ultrasound wand can form a kit. Other embodiments can have different elements or combinations of elements grouped and/or packaged together. Kits can be sold or distributed separately from or with the other portions of the system.

[0048] One will readily recognize that there are numerous other examples of image guidance systems which can use, incorporate, support, or provide for the techniques, methods, processes, and systems described herein.

Depicting Surgical Instruments

[0049] Previous systems do not provide satisfactory image guidance data. It can often be difficult to discern the content of a 3D scene from a 2D depiction of it, or even from a 3D depiction of it. Therefore, various embodiments herein provide image guidance that can help the doctor better understand the scene, relative emplacements or poses of object in the scene and thereby provide improved image guidance.

[0050] FIG. 2 illustrates a virtual rendering 201 of an exemplary surgical instrument 245 being displayed on a screen 220. In this case, the surgical instrument displayed is an ablation needle 245. The wire 246 connecting the ablation needle 245 to an ablation system is also depicted. Although only one surgical instrument 245 is displayed, it will be understood that multiple surgical devices can be tracked and displayed simultaneously on screen 220, as described in greater detail below with reference to FIG. 11-17.

[0051] The virtual surgical instrument 201 can be displayed in a virtual 3D space with the screen 220 acting as a window into the virtual 3D space, which can also be referred to as the perspective view. Thus, as the surgical instrument 245 is moved to the right, the virtual surgical instrument 201 also moves to the right. Similarly, if the surgical instrument 245 is rotated 90 degrees so that the tip of the surgical instrument is pointing towards the screen 220, the virtual surgical instrument 201 will likewise show the change in orientation, and show the tip of the virtual surgical instrument 201 in the background and the other end of the image 201 in the foreground.

[0052] Some models of medical devices have markings such as bands around the shaft (to indicate distance along the shaft), and a colored region near the tip to indicate where the radio frequency or microwave energy is emitted from in the case of an ablation probe. Healthcare providers performing medical device procedures are often familiar with these markings and can use them to help understand the spatial relationship between the medical device and anatomy. In some embodiments, the make and model of the medical device 245 is known to the image guidance system and the virtual medical device displayed (201) in display 220 can resemble medical device 245. The features of medical devices that can be rendered in the scene include the overall shape (diameter, cross sectional shape, curvature, etc.), color, distance markers, visuals or echogenic fiducial markers, the state of deployable elements such as tines, paddles, anchors, resection loops, stiffening or steerable sleeves, temperature, radiation, light or magnetic field sensors, lens, waveguides, fluid transfer channels, and the like.

[0053] The type of medical device being used can be input into the image guidance system, can be a system default, can be detected by a camera or other device, can be received as data from an attached medical device, such as surgical system 149 in FIGS. 1A and 1B, or the information can be received in any other appropriate manner. Making the surgical instrument displayed on display 220 resemble the surgical instrument 245 can help healthcare providers associate the image guidance data with the real world and can provide more familiar guidance information to a healthcare provider, thereby further aiding the healthcare provider in

the guidance task. For example, the healthcare provider can see the familiar markings on the medical device being displayed on the display 220 and therefore be familiar with the distance and relative placement of the displayed medical device with respect to other data, such as a tumor seen in an ultrasound (not depicted in FIG. 2). This knowledge of relative placement of items being displayed can help the healthcare provider move the medical device into place.

[0054] Consider an embodiment in which the virtual surgical instrument 201 in the display 220 is an ablation needle depicting the portion of the needle that will perform the ablation, for example, the portion that emits the radio or microwave energy. If the display 220 also includes ultrasound data, then the doctor can be able to find the tumor she wishes to ablate by moving the ultrasound probe around until she spots the tumor. In various embodiments, she will be able to see the displayed ultrasound data and its location relative to the displayed medical device with the markings. She can then drive the medical device until she sees, on display 220, that the emitter-portion of the medical device encompasses the tumor in the ultrasound, also seen on display 220. When she activates the ablation, she can then be much more certain that she has ablated the correct portion of the tissue. Various embodiments of this are discussed more below.

[0055] As another example, consider the physical markings that can be on the instruments themselves. These markings can help orient a healthcare provider during use of the instrument. In some embodiments, the image guidance unit can represent these markings in the images displayed in the display. For example, certain ultrasound transducers are built with an orientation mark (e.g., a small bump) on one side of the transducing array. That mark can also be shown in the ultrasound image on the scanner's display, to help the healthcare provider understand where the scanned anatomical structures shown on screen are located under the transducer, inside the patient. In some embodiments, the image guidance system can display a symbolic 3D representation of the orientation mark both next to the motion-tracked ultrasound slice (e.g., moving with the displayed ultrasound slice) and next to the 2D ultrasound slice also displayed by the system. An example of this is displayed in FIG. 5, where a small rectilinear volume corresponding to a feature on an ultrasound probe is shown both in proximity to the ultrasound slice displayed in 3D and the ultrasound slice displayed as a 2D image.

[0056] Other embodiments can track and display other types of instruments and their features. For example, a healthcare provider may want to track one or more of a scalpel, a biopsy, a cauterizer (including an electrocauterizer and Bovies), forceps, cutting loops on hysteroscopes, harmonic sheers, lasers (including CO.sub.2 lasers), etc. For example, in various embodiments, the following devices can be tracked and various aspects of their design displayed on display 220: Olympus™ OES Pro Hystero-Resectoscope, SonoSurg Ultrasonic Surgical System Olympus™ GF-UC 160 Endoscope Wallus™ Embryo Transfer Catheter Angio-Dynamics®, NanoKnife™, VenaCure™ laser, StarBurst, Uniblade, Habib®, Resector Bovie™ Electrodes, Covidien Evident™, Cool-tip™ Ablation Antennas, Opti4™ Electrodes Microsulis MEA (microwave endometrial ablation), Acculis Halt™ Medical System Optimed BigLumen Aspi-

ration Catheter Optimed Optipure Stent Central venous catheterization introducer medical device (such as those made by Bard and Arrow).

[0057] Once tracked, a healthcare provider is able to see image guidance data on display **220** that will allow her to know the relative pose, location, or emplacement of the tracked instrument(s) with respect to one another or with respect to imaging data and will be able to see, on display **220**, the features of the instrument rendered in the scene.

Depicting Ablation Volume and Other Instrument Information

[0058] Various embodiments of the systems herein depict as part of the image guidance data information related to the surgical instruments. For example, in some embodiments, an image guidance system such as the systems of FIG. 1A or 1B can illustrate an expected spherical ablation volume. For example, FIG. 3 shows an ablation needle **345** which has a darkened portion that indicates where the radio frequency or microwave energy for ablation will be emitted. In some embodiments, an image guidance system can display on display **320** the expected ablation volume **302**. The ablation volume **302** can be shown as a transparent volume, a wireframe volume (depicted in FIG. 3), as a point cloud of various densities, as an outline, as a volume, or in any other appropriate manner. Although only one ablation volume **302** is displayed, it will be understood that multiple ablation volumes can be displayed for each medical device **345** that is displayed on the screen **320**.

[0059] For some ablation needles, the expected volume of ablated tissue is neither spherical nor centered at the tip of the medical device. For example: a Covidien surgical microwave medical device has an ellipsoidal ablation volume; a Covidien Evident transcutaneous microwave medical device has a teardrop-like ablation volume; RFA Medical's bipolar ablation system uses two medical devices simultaneously, where each medical device has paddles that deploy after the medical device is inserted inside the tissue (which one can equate to a canoe's oar). In some embodiments, the ablation volume for such a medical device is, to a first approximation, a volume that lies directly between the paddles of the two medical devices.

[0060] The position and orientation of the volume can be specified by the placement of a tracked medical device, such as medical device **345** in FIG. 3. In some embodiments, with single medical device ablation systems, the volume's approximate size (e.g., girth and length, if ellipsoidal) can be either specified by the healthcare provider, or automatically computed by the guidance system. The ablation volume can be based on numerous parameters such as the medical device make and model, power and duration settings of the microwave or radio frequency generator, measured or estimated temperature and impedance of the target tissue or other tissue information, a formula, a look-up-table, fixed or default values, or based on any other appropriate available information.

[0061] Other instrument information can also be depicted. For example, if a cauterizer is tracked as part of an image guidance system, then the cauterization volume can be determined or estimated and that volume can be displayed. If a laser is tracked as part of the image guidance system, then the projected laser path can be determined or estimated and displayed. In embodiments where multiple medical

devices are used, the combined volume can be shown, as described in greater detail below with reference to FIGS. 12A and 12B.

Depicting Medical Device Placement Trajectory, and Other Prediction Information

[0062] In certain procedures, the system can provide prediction information related to the surgical instruments. In the context of scalpel movement, this can be the location that the scalpel will hit if a healthcare provider continues to move the scalpel in a particular direction. In the context of ablation or biopsies, this can be the projected medical device placement if it is driven along its central axis, which is also referred to herein as a longitudinal axis.

[0063] FIG. 4 illustrates both an ablation volume **404** for an ablation needle **445** and a projected needle drive **403**. If a healthcare provider is driving an ablation needle **445** into tissue (not pictured), then she can know where the medical device will be driven. In some embodiments, the projected drive of a medical device can be depicted on the display **420** and can show the healthcare provider the projected path **403** that the medical device will take if it is driven along its central axis. Although the trajectory of only one medical device is displayed, it will be understood that the trajectory of multiple medical devices can be determined and displayed simultaneously on screen **420**, as described in greater detail below with reference to FIGS. 12A, 12B, 13A, and 13B.

[0064] In some embodiments, in order to aid the healthcare provider in placing or orienting a medical device **445**, an image guidance system, such as that depicted in FIG. 1A or FIG. 1B, can draw a number of rings about the axis of the medical device shaft, extrapolated beyond its tip, as depicted in FIG. 4. A healthcare provider can view and manipulate the position and orientation of the medical device **445** and its expected drive projection (via its displayed projected trajectory) before it enters the patient's tissue. In some embodiments, this is accomplished by the doctor positioning the virtual rings in the drive projection such that they are co-incident (or pass through) the ultrasound representation of a target, such as a tumor that the doctor has spotted in the ultrasound. This can allow the healthcare provider to verify that the medical device **445** is properly aimed at the target and can drive the medical device **445** forward into the tissue such that it reaches its desired target or destination. For example, if the doctor identifies a tumor in the ultrasound image (not pictured in FIG. 4), she can align the ablation needle **445** such that the drive projection rings on display **420** intersect or otherwise indicate that the medical device, if driven straight, will reach the tumor.

[0065] The rings can be spaced at regular (e.g., 0.5, 1, or 2 cm) intervals to provide the healthcare provider with visual or guidance cues regarding the distance from the medical device tip to the targeted anatomy. In some embodiments, the spacing of the rings can indicate other aspects of the data, such as the drive speed of the medical device, the density of the tissue, the distance to a landmark, such as the ultrasound data, or any other appropriate guidance data or property. In some embodiments, the rings or other trajectory indicators can extend beyond the medical device tip, by a distance equal to the length of the medical device-shaft. This way, the user knows if the medical device is long enough to reach the target—even before the tip enters the patient. That is, in some embodiments, if the rings do not reach the target

with the tip still outside the body, then the tip won't reach the target even when the entire length shaft is inserted into the body.

[0066] Other display markers can be used to show trajectory, such as a dashed, dotted, or solid line, transparent medical device shaft, point cloud, wire frame, etc. In some embodiments, three-dimensional rings can be used and provide depth cues and obscure little of the ultrasound image. Virtual rings or other virtual markers can be displayed semi-transparently, so that they obscure less of the ultrasound image than an opaque marker would.

[0067] Other prediction information can also be displayed. For example, if a scalpel is being tracked by the image guidance system, then a cutting plane corresponding to the scalpel can be displayed (not pictured). Such a cutting plane can be coplanar with the blade of the scalpel and can project from the blade of the scalpel. For example, the projected cutting plane can show where the scalpel would cut if the doctor were to advance the scalpel. Similar prediction information can be estimable or determinable for cauterizers, lasers, and numerous other surgical instruments.

Depicting Combinations of Graphics

[0068] As discussed herein, when there are multiple instruments or devices being used in a procedure, images, graphics, and data associated with the multiple instruments can be displayed to the healthcare provider. In some embodiments, as depicted in FIG. 5, when there are two medical devices 545 and 555 being used and tracked in a procedure, data, images, and graphics associated with those two images can be combined and displayed on the same display.

[0069] FIG. 5 depicts an ablation needle 545 and an ultrasound probe 555 being used during a procedure. Data associated with each of the devices 545 and 555 are displayed on the display 520. As described previously with reference to FIG. 2, the devices 545 and 555 can be displayed in a virtual 3D space with the screen 520 acting as a window into the virtual 3D space and providing a perspective view. Thus, as the surgical instrument 545 are moved to the right, the virtual surgical instrument 501 also moves to the right. Similarly, if the ultrasound probe 555 is moved to the right, the ultrasound image 504 is also moved to the right. If the surgical instrument 545 is rotated 90 degrees so that the tip of the surgical instrument is pointing towards the screen 520, the system 100 will likewise adjust the virtual surgical instrument 501 to show the change in orientation, and show the tip of the virtual surgical instrument 501 in the background and the other end of the virtual surgical instrument 201 in the foreground. Similarly a rotation of the ultrasound probe 555 will result in a rotation of the ultrasound image 504.

[0070] The data from two or more devices can be combined and displayed based on their relative placements or poses. For example, the system 100 can determine an image plane based on the emplacement information of the ultrasound probe 555. Further, the ultrasound image 504 can be displayed on the image plane with respect to a virtual ablation needle 502 on a display 520 in a manner that estimates the relative placements or poses of an ultrasound probe 555 and ablation needle 545. As illustrated in FIG. 5, the graphics associated with the virtual ablation needle 502, including the ablation volume 506 and projected drive location 508, are shown spatially located with the oriented planar ultrasound image 504 on display 520.

[0071] In addition, the display 520 includes an intersection indicator 510 that indicates the where the virtual ablation medical device 502 intersects the ultrasound image 504. In some embodiments, the intersection indicator 510 can be displayed before the medical device is inserted, thereby allowing the healthcare provider to see where the medical device will intersect the image.

[0072] In this image, a tumor 512 appears in the ultrasound image 504 and the virtual ablation needle 502 is shown driven through the tumor 512. The ablation volume 506 estimates where ablation would occur if the tissue were ablated at that time. The healthcare provider can see that the ablation volume 506 appears to cover the tumor displayed in the ultrasound image.

[0073] Various embodiments can include any combinations of the graphics described above with reference to FIGS. 2-7 and/or other graphics. For example, in some embodiments, data related to a single surgical instrument (such as an ablation needle, ultrasound probe, etc.) can be presented in more than one manner on a single display. Consider an embodiment in which device 545 is an ablation needle and device 555 is an ultrasound transducer. As mentioned previously, as the medical devices are displayed in a virtual 3D space, with the screen 520 acting as a window into the virtual 3D space, if a healthcare provider orients ultrasound transducer 555 such that it is perpendicular to the monitor, the 3D view of the ultrasound image would show only the edge and the ultrasound image would not be visible. In some embodiments, the image guidance system can track the healthcare provider's head using a position sensor, such as first and/or second position sensing units 110 and/or 140 of FIG. 1A or FIG. 1B. The healthcare provider can then move her head to the side, so that she sees the ultrasound image from a different perspective.

[0074] In some embodiments, the image guidance system can constantly display an additional 2D view of the ultrasound image 505 (in screen space), simultaneous to the 3D depiction of the procedure, so that the ultrasound image is always visible, regardless of the orientation in which the healthcare provider holds the transducer. This is illustrated in FIG. 5. This display of the ultrasound data can be similar to what a healthcare provider is accustomed to seeing with traditional ultrasound displays. This can be useful to provide the healthcare provider with imaging to which she is accustomed and allows a healthcare provider to see the ultrasound data regardless of the then-current orientation of the ultrasound probe with respect to the user.

[0075] In some embodiments, the 2D view 505 of an ultrasound image is depicted in the upper right corner of the monitor (though it can be placed in any location). In some embodiments, the guidance system can automatically (and continually) choose a corner in which to render the 2D view of the ultrasound image, based on the 3D position of the surgical instruments in the rendered scene. For example, in FIG. 5, ablation needle 545 can be held in the healthcare provider's left hand and the medical device shaft is to the left of the 3D ultrasound image slice, so that the 2D ultrasound image 505 in the upper right corner of display 520 does not cover any of the 3D features of the medical device (or vice-versa). If the medical device were held in the healthcare provider's right hand, the virtual medical device shaft would appear on the right side. To prevent the 2D ultrasound image in the corner of display 520 from covering the medical

device shaft, the system can automatically move it to a corner that would not otherwise be occupied by graphics or data.

[0076] In some embodiments, the system attempts to avoid having the 2D ultrasound image quickly moving among corners of the display in order to avoid overlapping with graphics and data in the display. For example, a function f can be used to determine which corner is most suitable for the 2D ultrasound image to be drawn in. The inputs to f can include the locations, in the screen coordinate system, of the displayed medical device tip, the corners of the 3D ultrasound image, etc. In some embodiments, f 's output for any given point in time is independent of f 's output in the previous frames, which can cause the ultrasound image to move among corners of the display rapidly. In some embodiments, the image guidance system will filter f 's output over time. For example, the output of a filter g , for any given frame, could be the corner which has been output by f the most number of times over the last n frames, possibly weighting the most recent values for f most heavily. The output of the filter g can be used to determine in which corner of display **520** to display the 2D ultrasound image and the temporal filtering provided by g can allow the 2D ultrasound image display to move more smoothly among the corners of the display **520**.

[0077] In some embodiments, other appropriate virtual information can be overlaid on the 2D ultrasound image as well. Examples include: an indication of the distance between the medical device's tip and the point in the plane of the ultrasound image that is closest to the medical device tip; the cross section or outline of the ablation volume that intersects with the ultrasound slice; and/or the intersection point, box, outline, etc. between the medical device's axis and the ultrasound image plane.

Representing Spatial Relationships

[0078] At times, when three dimensional relationships are depicted in 2D, or even in 3D, it can be difficult to gauge the relative positions, orientations, and distances among various objects. Consider FIG. 5, in which an ablation needle is shown intersecting an ultrasound image. Depending on the embodiment, it can be difficult to determine the relative angle of the ablation needle and the ultrasound image as well as the distances of various portions of the image plane to the ablation needle.

[0079] In some embodiments, the image guidance system can indicate spatial relationships with graphical indicators. For example, in FIG. 6, graphical indicators help indicate the spatial relationship between a medical device and an ultrasound image plane. These also provide an indication of the relative angle of the medical device and the image plane.

[0080] In some unpictured embodiments, the image guidance system can draw "guidance graphics" in the form of projective lines between the medical device and the ultrasound slice. These lines can be perpendicular to the plane of the slice and serve to indicate the most likely location in the slice where the medical device will become visible if it is moved to become coplanar with the slice. Together with stereoscopic head-tracked visualization, the projective lines help a healthcare provider determine a more accurate assessment of the location of the medical device with respect to the ultrasound slice.

[0081] Returning to FIG. 6, in some embodiments, uniform-thickness lines **602** between virtual medical device and

the image plane can be displayed on display **620**. The lines can represent the spatial relationship with three-dimensional rectangular (or any shape) medical device projection bars, lines (dashed or solid), etc. In various embodiments, the projection bars can be drawn perpendicular to the image, and in such a way that their small edges are aligned with (or parallel to) either the vertical (FIG. 6) or the horizontal margins of the ultrasound slice. In some embodiments, the screen-space size of the projection bars can be variable (e.g., distance-dependent) due to perspective. Thus, they can provide depth cues for the healthcare provider. Further, the staircase appearance of the bars' end edges at the plane of the slice can be a further visual cue for the orientation of the medical device with respect to the image plane.

Representing Non-Intersecting Objects or Images

[0082] When data related to two devices or surgical instruments are displayed with relative emplacement, it can be difficult to orient their relative locations if they do not intersect. In some embodiments, an image guidance system will render relative location information. The relative location information can be shown with color (e.g., objects can be rendered in brighter colors if they are closer), with rendering techniques (e.g., objects can be rendered with transparency so that one object behind another can be visible, but visually appear behind the closer object), with geometry (e.g., a geometric connector can be shown that will allow the viewer to discern the relative relationships), or with any other appropriate technique. FIG. 7 illustrates example geometry and transparency being used to show relative locations of two objects.

[0083] For example, in some embodiments, if the intersection point of a medical device **702** is outside of the area of the ultrasound slice **704**, the image guidance system can draw geometry, such as a line (or rectangle) in the image plane to indicate the relative positions of the medical device (s) and ultrasound image. This is depicted in FIG. 7. In some embodiments, the relative locations can also be represented using vertical and horizontal elements coplanar with the ultrasound or other image. In some embodiments, using geometry that is coplanar with the ultrasound image slice can provide an intuitive understanding of the relative locations of an image slice and an ablation needle.

Marking Points of Interest

[0084] In certain procedures, healthcare providers desire to keep track of multiple spots within the volume of the patient or keep track of a single point or feature while looking at other parts of the volume. For example, when a healthcare provider is going to perform an ablation, before inserting any medical devices, the healthcare provider will often scan the tissues at the procedures site to find all targets (e.g., tumors) and note other features of the tissues. Then, later in the procedure, the healthcare provider can return to the previously identified points-of-interest. For example, a healthcare provider might first scan the liver and find seven lesions that she will attempt to ablate. After ablating the first lesion, she might be required to find the second lesion again, and so forth. Before finishing the procedure, she might be required to verify that she has ablated all seven of the lesions that she identified at the beginning of the procedure. This constant scanning and rescanning can be time consuming and error prone. Further, in a procedure where the healthcare

provider is attempting to locate, for example, fluid-filled cysts, once a medical device pierces the cyst, the fluid can drain out, making the target difficult or impossible to locate again with ultrasound.

[0085] In some embodiments, the image guidance system allows the healthcare provider to mark or keep track of points or features of interest. In various embodiments, the healthcare provider can mark the points or features of interest in various ways. For example, consider a procedure where the doctor is using the image guidance system with an ablation needle and an ultrasound probe. The doctor can be able to mark the point by pressing a button on a keyboard or medical device, by gesturing or issuing a verbal command, or with any other appropriate method. The point of interest can be marked at the point where the medical device intersects with the ultrasound image plane, where the medical device's projection intersects with the ultrasound image plane, or any other appropriate relationship (such as at the location of the tip of the medical device). For example, when the healthcare provider identifies a point-of-interest within the ultrasound image, she can point to it using the medical device even if the medical device is outside the body of the patient. This is depicted in FIG. 8. The healthcare provider (or assistant) can then press, for example, a button or foot pedal, which informs the image guidance system to store the 3D position of this point-of-interest 801. FIG. 8 illustrates an X being displayed where a point of interest 801 has been marked. In some embodiments, the system can then display the position of this point-of-interest 801 relative to the ultrasound plane and the medical device. For example, an X-shaped marker 902 can be displayed on display 920 to show the relative position of the marked position and the surgical instruments, as depicted in FIG. 9. In some embodiments, the system can also display a bar that connects the X marker 902 of the point-of-interest to the nearest point (or the point to which a normal vector of the image plane would reach the X), as depicted in FIG. 9. This visually indicates to the healthcare provider the distance between the ultrasound image and this point-of-interest. Should the healthcare provider want to see the point of interest again in the live ultrasound image, the graphics indicate to where she should move the ultrasound transducer to view that point in the ultrasound image. In some embodiments, the image guidance system can also display the numerical distance (e.g., in mm) between the ultrasound image and the point-of-interest (not shown).

[0086] Healthcare providers, during some liver ablation procedures, can manage fifteen points-of-interest, or even more. As depicted in FIG. 9, in some embodiments, there can also be multiple markers 902 of point of interest simultaneously displayed. The image guidance system can be able to store and display any number of points of interest simultaneously. If there is more than one point-of-interest in view, the image guidance system can display a number next to each one (not pictured). In some embodiments, in order to reduce visual clutter if there are many points of interest, those points which are closer to the ultrasound image plane are drawn more saliently or vividly (with more bold color and thicker lines) while the points that are far away are drawn less saliently (more transparent, blurred, muted colors, etc.). Additionally, in various embodiments, other representations other than an X (such as a point, point cloud, sphere, box, etc.) can be used and multiple markers or locations can be represented with different markings.

[0087] In some embodiments, the image guidance system stores the points-of-interests' positions in the position sensing system's coordinate system. If the position sensing system is fixed to the image guidance system, then, if the patient or image guidance system are moved, stored points-of-interest can become incorrectly located. In some embodiments, this can be remedied via a fiducial or other detectable feature or item, the pose of which relative to the tracking system can be continually, continuously, periodically, or occasionally measured. The fiducial can be attached to the operating table, the patient's skin, or even embedded into the tissue itself (e.g., as a magnetic tracking coil), and the points-of-interest' positions, relative to it, can be stored and displayed. For example, in a system where magnetic tracking is used, a magnetic tracking coil can be affixed to the operating table or patient. In some embodiments, the healthcare provider can draw the annotations.

[0088] FIGS. 10A-10D illustrate examples of image annotation in image-guided medical procedures. FIGS. 10A-10D show a representation on a computer screen 1020 of an annotation being made with a medical device (represented on the display 1020 as medical device 85). The medical device can be used to annotate an image 1056. FIG. 10A illustrates the manipulation of a medical device 85 pointing at an image 1056 (e.g., an ultrasound image 1056). The operator can make an annotation by moving the medical device 85 through space in order to draw curve 1071 on image 1056. In certain embodiments, arrow 1074 can indicate the direction that the operator plans to or will draw in the future. In some embodiments, arrow 1074 is not displayed. Location indicator 1080 can represent the place on image 1056 currently pointed to by medical device 85. Location indicator 1080 can be any appropriate indicator such as an "X," an arrow, a differently-colored area, etc. In FIG. 10B the operator has further moved medical device 85 in order to complete the annotation 1071 on image 1056. As is depicted in FIG. 10B, the indicator 1080 of the intersection between the axis of the medical device 85 and the image 1056 has now reached the lower-right quadrant of the image 1056.

[0089] The image 1056 can be associated with a medical device, such as an ultrasound transducer (not pictured in FIGS. 10A-10D). The image 1056 can be an ultrasound image 1056, or the image 1056 can be a slice or image from other 3D visualizable medical data such as is described above.

[0090] The annotation 1071, although it has been drawn on an image 1056, can be located in the virtual 3D space—defined by the placement of the image 1056 and the annotation 1071. FIG. 10C depicts image 1056, associated with the ultrasound transducer turned or rotated about its vertical axis (axis not depicted in FIG. 10C). Therefore, part of the annotation 1071 is depicted in front of the image 1056, and part of the annotation 1073 is behind the image 1056, thus illustrating the existence in the virtual 3D space of the annotation 1071/1073. The location and display of annotations in the virtual 3D space allow an operator to make an annotation for a feature (e.g., a tumor, cyst, or vein), and allow her to locate that feature again later.

[0091] FIG. 10D illustrates that an operator can make a second annotation 1072 on the image 1056. Part of the first annotation 1071 is in front of the image 1056 and part 1073 is behind. By manipulating the pose of the image 1056 (e.g. by manipulating the ultrasound transducer), the operator can

choose new locations within 3D space for annotations. As noted above, the annotations can be for a blood vessel, tumor, or any other object or location of interest for the operator. There need not even be a particular object in the medical image that the operator is annotating. The operator can, for example, sign her name or write a note. For example, an operator can circle or make marks near multiple tumors, trace a line such as annotation **1071** along a vein or artery, etc. In some embodiments, if the operator moves image **1056** during annotation, the operator can make non-planar annotation (see, e.g., FIGS. **2** and **3**). As such, the operator can make a sphere or other non-planar annotation in order to annotate the volumetric aspects of a feature of interest. For example, the operator can draw the outline of a sphere around a tumor or cyst.

Multiple Medical Device Tracking

[**0092**] FIG. **11** is a diagram illustrating various features of multiple medical devices **1102**, **1104** that can be tracked by the system. Although two medical devices are illustrated, it will be understood that the system can track and/or display fewer or more medical devices as desired. In the illustrated embodiment, each medical device has a tip **1106A**, **1106B**, an exposed electrode **1108A**, **1108B**, an insulating tube **1110A**, **1110B**, and are associated with one or more tracking units (not shown), each of which are described in greater detail above.

[**0093**] Using the emplacement information received from the tracking units, the system can calculate the emplacement of each medical device within a predefined area as well as the relative emplacement with respect to each other. The system can also determine the longitudinal axis **1112A**, **1112B** (also referred to as the central axis) of the medical devices **1102**, **1104** and use the longitudinal axes to calculate the trajectories, of each medical device, angle differences between the medical devices, etc. This data can be used to generate useful information for display for the healthcare provider.

[**0094**] As mentioned previously, in some medical procedures that use multiple medical devices, it is desirable to have the medical devices on the same plane (e.g., the tips on the same plane) and parallel with each other. The system described herein can aid a healthcare provider in placing the medical devices so that they are level and parallel with each other.

[**0095**] During, or prior to, a medical procedure, one of the medical devices can be selected as the foundational medical device. In the illustrated embodiment of FIG. **11**, medical device **1102** is selected as the foundational medical device. In some embodiments, the foundational medical device is selected as the first medical device placed in the tissue, and secondary medical devices (e.g., medical device **1104** in the illustrated embodiment) are placed thereafter. In certain embodiments, the foundational medical device is **1102** selected by the user and the remaining medical devices are the secondary medical device **1104**.

[**0096**] Once a foundational medical device is selected, the system can calculate one or more foundational planes, and can generate foundational plane indicators for the different foundational planes. As used herein, a foundational plane is a plane that is perpendicular to a trajectory of the foundational medical device and intersects at least one point of the foundational medical device and/or intersects at least one point in the trajectory of the foundational medical device. In

some embodiments, the trajectory of the foundational medical device is determined by the longitudinal axis of the foundational medical device.

[**0097**] Accordingly, a variety of foundational planes can be calculated and used as described herein. For example, the foundational tip plane **1114** is a foundational plane that intersects a tip of the foundational medical device **1102**. As another example, the foundational electrode plane **1116** is a foundational plane that intersects the electrode of the foundational medical device **1102**. In some embodiments, the foundational electrode plane intersects the electrode at a location where the exposed electrode **1108A** ends, such as where the exposed electrode meets the insulated tube **1110A** or handle. In certain embodiments the foundational electrode plane **1116** intersects the exposed electrode **1108A** at any location.

[**0098**] The emplacement information can also be used to calculate various distances between the foundational medical device and other medical devices and between the foundational planes and the medical devices. In some embodiments, the emplacement information can be used to calculate the relative distance **1118** between the tips **1106A**, **1106B** of the medical devices **1102**, **1104**.

[**0099**] In certain embodiments, the emplacement information can be used to calculate the horizontal distance **1120** between the tips **1106A**, **1106B** of the medical devices **1102**, **1104**. The horizontal distance **1120** can represent the distance between the tips **1106A**, **1106B** if the tips were (or are) level (e.g., on the same plane, such as the foundational tip plane). In some embodiments, the horizontal distance can be calculated by determining the distance between the tip **1106A** of the foundational medical device **1102** and the location of the tip **1106B** of the secondary medical device **1104** if the secondary medical device **1104** were on the foundational tip plane **1114**.

[**0100**] The emplacement information can also be used to calculate the vertical distance **1122** between the tips **1106A**, **1106B** of the medical devices **1102**, **1104**. The vertical distance can **1122** represent the distance one tip is in front of or behind the other tip (e.g., how far the tip of one medical device is from the foundational tip plane). In some embodiments, the vertical distance can be calculated by determining the distance between the tip **1106B** of the secondary medical device **1104** and the foundational plane **1114**. This information can be used to determine whether the medical devices **1102**, **1104** are level (e.g., whether the tips are on the same plane, such as the foundational tip plane).

[**0101**] The emplacement information can also be used to calculate the relative difference in degrees between the medical devices **1102**, **1104** (e.g., how many degrees from being parallel). For example, the system can compare the longitudinal axis **1112A** of the foundational medical **1102** with the longitudinal axis **1112B** of the secondary medical device **1104** to determine how many degrees difference there is between the two. The difference in degrees can be displayed as a number or graphical indicator. For example, the system can provide projective lines as discussed previously and also in greater detail below with reference to FIGS. **12C** and **12D** to indicate the difference in degrees between medical devices. The number or graphical indicator can aid a user in placing the needles parallel to each other. This can be used in conjunction with the foundational plane information to place the needles level (e.g., the tips on the same plane) and parallel with each other.

[0102] The emplacement information can also be used to determine a target axis 1124 for the secondary medical device 1104. In some embodiments, the target axis 1124 can be the axis at which the secondary medical device 1104 is to be placed. The target axis 1124 location can be based on user input entered prior to or during the procedure, such as where the user wants the secondary medical device to be placed for a medical procedure and/or dynamically determined based on the emplacement of the foundational medical device 1102. In certain embodiments, the target axis 1124 is a predetermined distance from and parallel to the longitudinal axis 1112A of the foundational medical device 1102. The predetermined distance can be selected by a user or dynamically determined by the system 100 based on the length of the exposed electrodes of the medical devices, a model of the ablation or biopsy parameters of the medical devices (e.g. a lookup table), 4) tumor size, etc.

[0103] In some embodiments, the system can determine relative spatial indicators that indicate the relative distance between portions of the secondary medical device 1104 and the target plane or target axis (e.g., the longitudinal axis 1112A of the foundational medical device 1102, location of the preferred placement of the secondary medical device 1104, etc.). In certain embodiments, the relative spatial indicators can indicate the distance from portions of the secondary medical device 1104 to corresponding portions of the foundational medical device 1102.

[0104] Once the system determines one or more of the parameters described above, it can cause a display device to display those parameters. In some embodiments, one or more of the determined parameters are displayed for each medical device that is being tracked. In certain embodiments, the system displays one or more parameters of a selected medical device (or multiple selected devices) that is being tracked. In some embodiments, the one or more parameters of the selected medical device are displayed in conjunction with the foundational medical device.

[0105] A user can select the selected medical device using any number of different inputs (e.g., touchscreen, keyboard, mouse, foot pedal, button, etc.). Once the selected medical device is selected, the system can cause the display device to display one or more of the associated parameters. For example, when a user is attempting to place a medical device during a procedure, she can press a button that causes the medical device to be the selected medical device. In response, the system can display one or more parameters associated with the selected medical device, such as, but not limited to, trajectory, intersection indicators, relative spatial indicators, etc., as will be described in greater detail below with reference to FIGS. 12A-12D.

[0106] In addition, the system can use the emplacement information to determine a perspective view of the virtual 3D space. For example, the system can use any one or a combination of the following points as the center of perspective for the perspective view: an image (e.g., center of an ultrasound image); the center of the foundational needle; the center of the exposed electrode 1108A of the foundational medical device 1102, the center of the exposed electrode 1108B of the selected secondary medical device 1104 (or other secondary medical device); the location between the foundational medical device 1102 and the selected secondary medical device 1104; the center of the exposed electrode of a non-selected secondary medical device; the center of all medical devices selected thus far in

the procedure; the center of all medical devices within a distance from the foundational medical device; the center of all medical devices.

[0107] Using the emplacement information and calculated data, the system can provide a user various indicators to aid in the placement of the medical devices, as will be described in greater detail below with reference to FIGS. 12A-17. The system can determine, calculate and/or display any of the emplacement information, or any combination of the emplacement information described herein in an embodiment.

Rendering with Multiple Medical Devices

[0108] FIGS. 12A-12D illustrate embodiments of displaying image guidance data for multiple medical devices. In the illustrated embodiments of FIGS. 12A and 12B, the display 1200 includes a 2D image display area 1202, as described in greater detail above with reference to FIG. 5, a 3D image display area 1204, and a relative emplacement measurement display area 1206. However, it will be understood that in some embodiments, fewer or more of the areas described can be included. For example, in certain embodiments any one or any combination of the areas mentioned above can be included in the display 1200.

2D Image Display Area

[0109] The 2D image display area 1202, described in greater detail above with reference to FIG. 5, can include an image 1223 and image guidance cues. The image 1223 can include any one of, or any combination of, an ultrasound image or images, ultrasound video, MRI, CT scan images, and/or any other image. In some embodiments, the image 1223 in the 2D image display area 1202 is the same as, or identical to, the image data provided in the 3D image display area 1204. In addition, the 2D image display area 1202 can include some or all of the image guidance cues and virtual medical devices described in greater detail below with reference to the 3D image display area 1204. In the illustrated embodiment of FIG. 12A, the 2D image display area 1202 includes trajectory indicators 1218, 1222 and an image plane intersection indicator 1226 overlaid onto an ultrasound image.

3D Image Display Area

[0110] The 3D image display area 1204 can represent a virtual 3D space that corresponds to an actual 3D space that is being tracked. In the illustrated embodiment, the 3D image display area 1204 includes a virtual medical imaging device 1208, an image 1210, as described in greater detail above with reference to FIGS. 2 and 5.

[0111] Furthermore, the 3D image display area 1204 can include multiple virtual medical devices 1212, 1214, 1216, image guidance cues (e.g., trajectory indicators 1218, 1220, 1222, image plane intersection indicators 1224, 1226, foundational plane indicators, 1228, 1330, and foundational plane intersection indicator 1232), a patient orientation indicator 1234, and medical provider indicator 1236.

[0112] Although three medical devices 1212, 1214, 1216 are displayed, it will be understood that fewer or more medical devices can be used and displayed as desired. In addition, it will be understood that in some embodiments not all of the features shown in FIG. 12A are present in the 3D image display area 1204. For example, in some embodi-

ments, any one or any combination of the features described above can be included in the 3D image display area **1204**. [0113] The multiple virtual medical devices **1212**, **1214**, **1216**, can be implemented by tracking emplacement information of multiple real medical devices located within a predetermined area. The predetermined area can correspond to a location of a medical procedure, the location of a patient, the location of tracking units, the range of position sensing units, a surgical table, an area corresponding to a virtual 3D area displayed on a display etc. Tracking emplacement information for a medical device is described in greater detail above with reference to FIGS. **1A** and **1B**. For example, a tracking unit can be associated with each medical device and provide emplacement information for the medical device. The system can use the emplacement information of the medical devices to generate the display illustrated in FIG. **12A**. Furthermore, as described previously with reference to FIGS. **2-10**, any one or any combination of cues can be displayed for each of the medical devices **1212**, **1214**, **1216**.

[0114] In some embodiments, each medical device and its associated image guidance cues (e.g. trajectory rings, intersection square, text, etc.) can be associated with a color. In some embodiments, each medical device with its associated image guidance cues is associated with a different color. For example, the first medical device **1212** and image guidance cues related to it can be drawn in pink, a second medical device **1214** and its associated image guidance cues can be drawn in green, and a third medical device **1216** and its associated image guidance cues can be drawn in blue. It will be understood that any combination of colors can be used as desired. Furthermore, the medical devices and associated image guidance cues can be distinguished based on different patterns or markings. For example, the system can cause the medical devices to have zigzags, lines, be bolded, flicker, etc.

Foundational Plane Indicators

[0115] In some embodiments, the image guidance cues can include foundational plane indicators, such as foundational plane indicators **1228**, **1230** and foundational plane intersection indicators, such as foundational plane intersection indicator **1232**. The foundational plane indicators **1228**, **1230** can indicate a location of a foundational plane and/or indicate a location where secondary medical devices are to be placed in order to be level with the foundational medical device. In some embodiments, the foundational plane indicators **1228**, **1230** can also indicate how the medical devices are to be placed so they are parallel to each other. The foundational plane intersection indicators (e.g., foundational plane intersection indicator **1232**) can indicate a location where the trajectory of a medical device intersects a foundational plane.

[0116] In the illustrated embodiment of FIG. **12A**, the first medical device **1212** is selected as the foundational medical device. As mentioned previously, the foundational medical device can be the first medical device placed in the tissue and/or selected by the user. Once the foundational medical device is selected, the system can calculate one or more foundational planes, as described in greater detail above with reference to FIG. **11**, and can generate foundational plane indicators. In the illustrated example of FIG. **12A**, the 3D image display area **1204** includes a foundational tip plane indicator **1228** and a foundational electrode plane

indicator **1230**. However, it will be understood that in some embodiments only one foundational plane indicator is displayed. Furthermore, in certain embodiments, three or more foundational plane indicators can be displayed.

[0117] In the illustrated embodiment, the foundational tip plane indicator **1228** extends from the tip of the foundational medical device **1212** to locations on the foundational tip plane where the tips of the secondary medical devices **1214**, **1216**, are to be placed. Accordingly, a user can use the foundational tip plane indicator **1228** to identify the location where the secondary medical devices **1214**, **1216** are to be located to be level with the foundational medical device **1212**. In certain embodiments, the foundational electrode plane indicators can indicate the location where the trajectories of the secondary medical devices intersect the foundational plane.

[0118] In some embodiments, the desired location for the tips of the secondary medical devices on the foundational tip plane is determined based on user input. For example, the user can indicate at what distances and locations the secondary medical devices are to be placed with respect to the foundational medical device. Based on the input, the system can determine the appropriate shape and size of the foundational tip plane indicator **1228**. In certain embodiments, the system dynamically calculates the location for the tips of the secondary medical devices on the foundational tip plane based on an identified object, such as a tumor, fibroid, etc., the size of the identified object, the number of medical devices to be used, electrical power specifications of the medical devices, etc.

[0119] In the illustrated embodiment of FIG. **12A**, the foundational tip plane indicator **1230** creates a triangular shape because three medical devices are used. However, it will be understood that the shape created by the foundational tip plane indicator **1228** can be any shape or line, and in some embodiments, is based at least in part on the number of medical devices used. For example, the foundational tip plane indicator **1228** can create a line when two medical devices are used (or when one medical device is selected as described in greater detail below in FIGS. **12B** and **12C**), a quadrilateral (e.g., square, rectangle, parallelogram, kite, etc.) when four medical devices are used, a pentagon when five medical devices are used, a hexagon when six medical devices are used, etc.

[0120] The foundational electrode plane indicator **1230** extends from the electrode of the foundational medical device **1212** to locations on the foundational electrode plane where the electrodes of secondary medical devices are to be placed. In the illustrated embodiment of FIG. **12A**, the foundational electrode plane indicator **1230** extends from a location on the foundational medical device **1212** where the electrode ends. However, it will be understood that the foundational electrode plane indicator **1230** can extend from any location on the foundational medical device. As described above, with reference to the foundational tip plane indicator **1230**, the foundational electrode plane indicator **1230** location and shape of the foundational electrode plane indicator **1230** can be determined based on user input, the number of medical devices used, and/or dynamically.

[0121] The foundational plane intersection indicator **1232** can be used to indicate where the trajectory of a medical device intersects with a foundational plane, or where a medical device will be if it is moved forward. In the illustrated embodiment of FIG. **12A**, the display **1200**

includes foundational plane intersection indicator **1232** indicating the intersection of the foundational tip plane and the trajectory of the medical device **1216**. However, it will be understood that a foundational plane intersection indicator can be used to indicate the intersection of any foundational plane with a trajectory of any medical device.

[0122] In some embodiments, the guidance cues (e.g., trajectory indicators, intersection indicators, etc.) associated with one or more medical devices are displayed simultaneously. In certain embodiments, the guidance cues associated with each medical device are displayed only when the associated medical device is selected. For example, in the illustrated embodiment of FIG. **12A**, the medical device **1216** is selected. Accordingly, the foundational plane intersection indicator **1232** indicates the intersection of the trajectory of the medical device **1216** and the foundational tip plane, and the image plane intersection indicator **1226** indicates the intersection of the trajectory of the medical device **1216** and the image plane.

Patient and Provider Indicators

[0123] The patient orientation indicator **1234** can indicate the orientation of the patient with respect to the perspective view of the 3D image display area **1204**. In the illustrated embodiment of FIG. **12A**, the patient orientation indicator **1234** indicates that the head of the patient is on the right side with respect to the image **1210**. In addition, in the illustrated embodiment of FIG. **12A**, the patient orientation indicator **1234** is implemented as a human figure, however, it will be understood that the patient orientation indicator **1234** can be implemented as any number of graphical indicators, such as a line, an arrow, a shape, etc. For example, an arrow can point in the direction of the head of a patient, or a shape or letter can be used to indicate the location of the head, feet, or other part of the patient. Furthermore, in some embodiments, the 3D image display area **1204** does not include the patient orientation indicator **1234**.

[0124] In some embodiments, the display **1200** can include a provider indicator **1236** that indicates the location of a medical provider with respect to the patient. The provider indicator can be implemented as a dot, shape, color, arrow, line, or any other graphical indicator to indicate the location of the medical provider with respect to the patient. The system can determine the location of the provider based on user input and/or dynamically based on one or more tracking units associated with the medical provider.

[0125] In certain embodiments, the location of the medical provider coincides with the perspective view of the virtual 3D space. In the illustrated embodiment of FIG. **12A**, the provider indicator indicates that the medical provider is located in front of the patient with respect to the perspective view. With reference to FIG. **12C**, the provider indicator **1236** indicates that the medical provider is located behind the patient with respect to the perspective view.

Placement Measurement Display Area

[0126] The placement measurement display area **1206** can provide a user with information regarding the placement of the medical devices. In some embodiments, the placement measurement display area **1206** provides relative placement information of the medical devices. For example, the placement measurement display area **1206** can indicate relative distances between the medical devices,

relative degrees between the medical devices, etc. The relative distances between the medical devices can include the distance between the ends of medical devices, the distance between other corresponding portions of the medical devices, the horizontal distance between corresponding portions of medical devices (e.g., the distance between a tip of the foundational medical device and the tip of the second medical device if the tip of the second medical device was on the foundational tip plane), the vertical distance between corresponding portions of medical devices (e.g., the distance between the foundational tip plane and the tip of a second medical device), etc. The relative degrees between the medical devices can include the difference in degrees between the longitudinal axis of one medical device and the longitudinal axis of another medical device or some other axis of the medical devices. The placement measurement display area **1206** can include any one of or any combination of the distances and/or degrees described herein.

[0127] In the illustrated embodiment of FIG. **12A**, the placement measurement display area **1206** includes the relative placement information of the medical devices **1212**, **1214**, **1216**, with respect to one another. For example, the placement measurement display area **1206** indicates that the tips of the medical devices **1214** (referenced by the '2') and **1216** (referenced by the '3') are 1.8 cm apart and are parallel. The placement measurement display area **1206** also indicates that the tips of the foundational medical device **1212** (referenced by the '1') and the medical device **1216** (referenced by the '3') are 2.1 cm apart and 1 degree off from one another (i.e., there is a 1 degree difference between the longitudinal axis of the foundational medical device **1212** and the medical device **1216**). The placement measurement display area **1206** further indicates that the tips of the foundational medical device **1212** (referenced by the '1') and the medical device **1214** (referenced by the '2') are 2.8 cm apart and 2 degrees off from one another. As mentioned previously, any one of, or any combination of, the placement information described previously can be included in the placement measurement display area **1206**. For example, the placement measurement display area **1206** can include the relative horizontal difference between portions of the medical devices and/or the relative vertical distances between portions of the medical devices, etc.

[0128] In some embodiments, the text indicating the distance between the tips of a pair of medical devices can be drawn in a first color (e.g., white) if it satisfies a threshold distance (e.g., 2 cm), and a second color (e.g., red) if it does not. Similarly, the angles can be drawn in the first color if they meet a threshold angle (e.g., 10 degrees), and the second color if they do not. It will be understood that other color schemes can be used as well. In some embodiments, the medical device numbers can be included next to the distances and angles, and in certain embodiments, the number of the medical device can be color-coded similar to the image guidance cues discussed previously.

Relative Location Indicators

[0129] As illustrated in FIG. **12B**, in certain embodiments, relative location indicators, such as relative location indicators **1238**, **1240**, can be used in place of, or in any combination with, one or more foundational plane indicators, such as foundational plane indicators **1228**, **1230** of FIG. **12A**. The relative location indicators **1238**, **1240** can indicate the

relative locations of corresponding locations of the medical devices. For example, the relative location indicators **1238**, **1240** can indicate the relative locations between the ends of the medical devices (e.g., location indicators **1238**), the exposed electrodes of the medical devices (e.g., location indicators **1240**) or other locations of the medical devices. Furthermore, the relative location indicators can be implemented as any graphical indicator between the corresponding locations of the medical devices. For example, the relative location indicators can be implemented as lines, bars, etc. between the corresponding locations of the medical devices. Furthermore, the shape of the location indicators can be any shape, as described in greater detail above with reference to FIG. **12A**.

[**0130**] In the illustrated embodiment of FIG. **12B**, the relative location indicators include a relative tip location indicator **1238** and a relative electrode location indicator **1240**, and are implemented as bars between the corresponding locations of the medical devices. The relative tip location indicator **1238** indicates the relative location of the tips of each of the medical devices **1212**, **1214**, **1216** with respect to one another and the relative electrode location indicator **1240** indicates the relative location of the ends of the exposed electrodes of each of the medical devices **1212**, **1214**, **1216** with respect to one another. It will be understood that in some embodiments, any one of, or any combination of, the relative tip location indicator **1238** and a relative electrode location indicator **1240** can be included in the display **1200**. Furthermore, it will be understood that other relative location indicators can be used in place of, or in any combination with, the relative tip location indicator **1238** and/or the relative electrode location indicator **1240**.

Multiple Medical Device Guidance—Relative Spatial Relationships

[**0131**] When multiple medical devices are depicted in 2D or 3D, it can be difficult to determine when the medical devices are parallel. Similarly, it can be difficult to determine the relative angle between a longitudinal axis of the foundational medical device and the longitudinal axis of another medical device. It can also be difficult to determine the distance between various portions of the foundational medical device and corresponding portions of a secondary medical device.

[**0132**] FIGS. **12C** and **12D** are diagrams illustrating the display **1200** with graphical indicators that indicate spatial relationships. For simplicity, the graphical cues described above with reference to FIGS. **12A** and **12B** are not shown. However, it will be understood, any one or any combination of the features described with reference to FIGS. **12A** and **12B** can be included as part of the embodiments described herein with reference to FIGS. **12C** and **12D**. Furthermore, as mentioned previously, in some embodiments only some of the features described herein are present. For example, in some embodiments, the display **1202** only includes the 3D image display area **1204**.

[**0133**] Furthermore, in the illustrated embodiment of FIG. **12C**, the medical device **1216** is selected for placement. Based on this selection, only the guidance cues associated with the medical device **1216** are displayed. However, it will be understood that similar guidance cues can be displayed for the other secondary medical device **1214**, as illustrated in FIG. **12C**. Furthermore, although illustrated as being displayed separately, it will be understood that the guidance

cues for more than one secondary medical device and/or the foundational medical device can be displayed simultaneously.

[**0134**] In the illustrated embodiment, the guidance cues include relative spatial indicators **1250** and foundational plane indicators **1252**, **1254**. The relative spatial indicators **1250** indicate the distance between portions of a longitudinal axis of the secondary medical device **1216** and portions of a target axis or target plane. In some embodiments, the target axis can be the axis at which the secondary medical device **1216** is to be placed. The target axis can be based on user input, such as where the user wants the secondary medical device **1216** to be placed and/or dynamically based on the emplacement of the foundational medical device **1212**. In certain embodiments, the target axis or target plane is parallel to the longitudinal axis of the foundational medical device **1212**. In some embodiments the target plane is the image plane, described previously.

[**0135**] In some embodiments, the relative spatial indicators **1250** indicate the relative distance between portions of the secondary medical device **1216** and the longitudinal axis of the foundational medical device **1212**. In certain embodiments, the relative spatial indicators **1250** can indicate the distance from portions of the secondary medical device **1216** to corresponding portions of the foundational medical device **1212**.

[**0136**] As the secondary medical device **1216** is moved closer to, or farther away from, the target axis or target plane, the spatial indicators **1250** can shorten or lengthen, respectively. If the secondary medical device **1212** is placed at the target axis or target plane, the spatial indicators **1250** can disappear. In some embodiments, if the secondary medical device **1212** is parallel to the target axis or target plane, the spatial indicators **1250** can be equal in length. However, if the secondary medical device **1216** is angled with respect to the target axis, the spatial indicators **1250** can have different lengths.

[**0137**] In the illustrated embodiment of FIGS. **12C** and **12D**, the spatial indicators **1250** are shown as rectangular bars, however, it will be understood that the spatial indicators **1250** can be implemented as any one of, or a combination of, bars, dashed lines, solid lines, symbols, etc.

[**0138**] In the illustrated embodiment of FIG. **12C**, the foundational plane indicators **1252**, **1254** include a foundational tip plane indicator **1252** and a foundational electrode plane indicator **1254**. It will be understood that in some embodiments, only one foundational plane indicator is displayed and in certain embodiments more than two foundational plane indicators are displayed.

[**0139**] The foundational plane indicators **1252**, **1254** are similar to the foundational plane indicators **1228**, **1230** described above with reference to FIGS. **12A** and **12B**. However, as illustrated, the foundational plane indicators **1252**, **1254** are graphical bars instead of shapes and indicate the location of the foundational plane with respect to the selected medical device (e.g., the medical device **1216**) and do not indicate the location of the foundational plane with respect to the other secondary medical device (medical device **1214**). However, as illustrated in FIG. **12D**, when the secondary medical device **1214** is selected, corresponding foundational plane indicators **1256**, **1258** can be displayed. As mentioned previously, the graphical cues associated with the different medical devices can be displayed simultaneously.

[0140] In some embodiments, the foundational plane indicators **1252**, **1254** can indicate when the secondary medical device **1216** is parallel with the foundational medical device **1212** and/or indicate when the secondary medical device **1216** is level with the foundational medical device **1212**. For example, the end of each foundational plane indicator **1252**, **1254** can include a line that indicates at what angle the medical device is to be placed in order to be parallel to the target plane or target axis. In certain embodiments, a number indicating the relative difference in degrees can be provided as part of the foundational plane indicators **1252**, **1254**.

[0141] It will be understood that any one, or any combination, of the embodiments described above with respect to the foundational plane indicators of FIGS. **12A** and **12B** can be used in place of, or in conjunction with, any of the embodiments of the foundational plane indicators **1252**, **1254** described above with reference to FIGS. **12C** and **12D**.

Multiple Medical Device Guidance Routine

[0142] FIG. **13** is a flow diagram illustrative of an embodiment of a routine **1300** implemented by the system **100** to display a plurality of virtual medical devices. One skilled in the relevant art will appreciate that the elements outlined for routine **1300** can be implemented by one or more computing devices/components that are associated with the system **100**, such as the position sensing units **110**, **140**, the image guidance unit **130**, surgical system **149**, and/or imaging unit **150**. Accordingly, routine **1300** has been logically associated as being generally performed by the system **100**. However, the following illustrative embodiment should not be construed as limiting.

[0143] At block **1302**, the system **100** receives emplacement information of a plurality of medical devices within a predetermined area. In some embodiments, the medical devices are invasive medical devices, such as ablation or biopsy needles, catheters, etc. As described previously, the medical devices, such as needles, can include tips, electrodes, and handles. In certain embodiments, the medical devices are non-invasive medical devices. In some embodiments, the medical devices are medical imaging devices, such as ultrasound transducers and/or laparoscopic cameras.

[0144] As described in greater detail above with reference to FIGS. **1A** and **1B**, each medical device can be associated with a tracking unit that provides emplacement information, such as position and orientation information. As described previously, the tracking units can be affixed to or implanted into the medical devices. Using the emplacement information of the tracking unit and known characteristics of the medical devices, the emplacement information can be determined. Accordingly, by receiving emplacement information from a tracking unit, the system **100** can also receive and/or determine emplacement information of the medical device.

[0145] At block **1304**, the system **100** calculates a viewing angle in a virtual 3D space of a plurality of virtual medical devices. The virtual medical devices can correspond to the medical devices that are being tracked. Further, the viewing angle can be based at least on the emplacement information of the plurality of medical devices. In some embodiments, the system calculates a viewing angle for each of the medical devices. In certain embodiments, to calculate the viewing angle, the system determines the emplacement of the medical devices with respect to a perspective view.

[0146] As mentioned previously with reference to FIG. **2**, the system **100** can use the emplacement information of the

plurality of medical devices with respect to the perspective view to determine how the virtual medical devices are to be displayed on a display. The perspective view can be determined based on user input and/or dynamically based on a position of the healthcare provider with respect to the display device and/or the medical devices. In some embodiments, the perspective view corresponds to the position of the healthcare provider with respect to the medical devices and/or with respect to the display. In addition, as discussed in greater detail with reference to FIG. **11**, the perspective view can be based on the number and location of the virtual medical devices as well.

[0147] At block **1306**, the system **100** causes a display device to display the plurality of virtual medical devices based at least on the calculated viewing angle(s) in the virtual 3D space. Based on the calculated viewing angle(s) and the perspective view, the system **100** can cause the display to display the medical devices with respect to one another. As the system **100** can calculate the viewing angle for each virtual medical device separately, each virtual medical device can be displayed at a different angle with respect to the perspective view. As mentioned previously, the perspective view can be based on the location of the healthcare provider, the location of an image in the virtual 3D space, the location and number of medical devices, etc.

[0148] As the position and orientation of the medical devices change, the system **100** can display the change with respect to the perspective view. For example, if the longitudinal axis of a virtual medical device is displayed as being left to right on the display and the medical device is rotated **90** degrees around the z-axis, the system **100** will change the display to show the longitudinal axis of the virtual medical device as being from the foreground to the background (or front to back).

[0149] Additional, fewer, or different blocks can be used to implement the routine **1300** without departing from the spirit and scope of the description. For example, any one or a combination of blocks **1308-1322** can be used as part of routine **1300**.

[0150] At block **1308**, the system **100** receives emplacement information of a medical imaging device within the predetermined area. As described previously, the medical imaging device can be an ultrasound transducer, laparoscopic camera, etc. Similar to the receipt of emplacement information described above with reference to block **1302**, the system **100** can receive emplacement information of the medical imaging device.

[0151] At block **1310**, the system **100** receives image data based at least on the emplacement information of the medical imaging device. In some embodiments, system receives one or more images from the medical imaging device. For example, the medical imaging device can be an ultrasound transducer and can provide one or more ultrasound images to the system **100**. As described in greater detail above with reference to FIGS. **1A** and **1B**, in some embodiments, the medical imaging device is used to select image data from a set of image data stored previously. For example, based on the emplacement of the medical imaging device, the system can receive images corresponding to a CT scan or MRI. In such embodiments, any device can be used as the medical imaging device.

[0152] At block **1312**, the system **100** calculates a viewing angle in the virtual 3D space of the image data (e.g., one or more images) based at least on the emplacement information

of the medical imaging device. As described previously with reference to block 1304, the system can calculate viewing angles in the virtual 3D space based on the emplacement information of the medical imaging device with respect to the perspective view. Using this information, the system 100 can calculate a viewing angle for image data in the virtual 3D space.

[0153] At block 1314, the system 100 causes the display device to display the image data based at least on the calculated viewing angle in the virtual 3D space. As described previously with reference to block 1306 the system can cause a display device to display images based on the calculated viewing angle. Similarly, the system 100 can cause the display device to display the image data (e.g., one or more images).

[0154] At block 1316, the system 100 identifies a foundational medical device. As described in greater detail above with reference to FIGS. 12A and 12B, the system 100 can identify the foundational medical device from among the medical devices being tracked. In some embodiments, the foundational medical device is the first medical device that is placed in the patient.

[0155] At block 1318, the system 100 determines one or more foundational planes and displays one or more foundational plane indicators, as described in greater detail above with reference to FIGS. 12A and 12B. As further described previously, the foundational planes can include a foundational tip planes, foundational electrode planes, etc. Once the foundational planes are determined, the system 100 can cause the display device to display foundational plane indicators corresponding to the foundational planes. The foundational plane indicators can indicate relationships between secondary medical devices and the foundational plane and between the foundational medical device and the foundational plane. Such information can be useful to a healthcare provider when placing the secondary medical devices. For example, the foundational plane indicators can indicate the location at which a secondary medical device is to be placed to be level with the foundational medical device (e.g., corresponding portions, such as the tip or handle, of the two medical devices are parallel).

[0156] At block 1320, the system 100 determines one or more foundational plane intersections and displays one or more foundational plane intersection indicators. As described in greater detail above with reference to FIGS. 12A and 12B, the system 100 can determine the points of intersection between the axis of the virtual medical devices and the foundational plane based on the emplacement information of the medical devices. Once determined, the system 100 can display indicators for those intersections. Using the indicators, the healthcare provider can identify where a medical device will intersect the foundational plane if pushed forward. Based on the desired placement of the medical device, the healthcare provider can change the position and orientation of the medical device as desired. Thus, the indicators can aid a healthcare provider during the placement of a medical device. Furthermore, the system can calculate distances between the foundational planes and the tips of the medical devices or other portions of the medical devices. The calculated distances can be displayed and/or used to display the medical devices.

[0157] At block 1322, the system 100 determines and displays one or more distances between the medical devices. As described in greater detail above with reference to FIGS.

12A and 12B, the system 100 can use the emplacement information to determine various distances between the medical devices. For example, the system 100 can determine the distance between the tips of two or more medical devices, the horizontal distance between two or more medical devices, and/or the vertical distance between two or more medical devices. The system 100 can display the distances as numbers and/or as graphical indicators as described above.

[0158] Furthermore, additional blocks can be used as part of the routine 1300. As described in greater detail above with reference to FIGS. 12A and 12B, the system 100 can determine and display many different parameters using the emplacement information of the multiple medical devices, such as angular differences between medical devices, trajectory intersections with an image plane, distances between the foundational plane and secondary medical devices, relative location differences of different portions of the medical devices with respect to target axis or target planes, and relative size of portions of the medical devices with respect to a target region. The angular differences between the axes of the medical devices can be displayed as a number or graphically as bars or lines between medical devices. The angular differences can be used to determine when two medical devices are parallel. The intersections of the trajectory of medical devices with an image plane can be indicated on the display to aid a healthcare provider in the placement of the medical device. The distances between the foundational plane and secondary medical devices can be displayed numerically or graphically and can aid the healthcare provider in placing the secondary medical devices with respect to the foundational medical device. The relative locations between different portions of the medical devices with respect to a target axis or target plane can be displayed graphically as described in greater detail above, with reference to FIGS. 12C and 12D, and used by a healthcare provider to aid in the placement of the medical devices. The relative size of portions of the medical device with respect to a target region can be displayed graphically, as described in greater detail below with reference to FIG. 14A and can help a healthcare provider determine whether the medical device is large enough to treat a target, such as a tumor.

[0159] In addition, as described above with reference to FIGS. 12A-12D, the system 100 can cause the display device to display a second set of the image data (e.g., in the

Medical Device Guidance—Planning Mode

[0160] FIG. 14A is a perspective view of an embodiment of a display in which the system provides medical device placement guidance to a user. In the illustrated embodiment, the display 1400 includes an image 1402, medical device placement suggestions 1404A and 1404B, a virtual medical device 1406, and guidance cues 1408, 1410, 1412. Furthermore, any one or any combination of the guidance cues described above with reference to FIGS. 2-11 and 12A-12D can be used in conjunction with any of the embodiments described herein with reference to FIGS. 14A and 14B. For example, the system can identify one of the medical devices or one of the suggested placements as the foundational medical device and can calculate and display the various guidance cues associated with the foundational plane, etc. Furthermore, it will be understood that although described in the context of providing guidance for the placement of multiple medical devices, the embodiments described herein

can provide guidance for the placement of a single medical device with respect to a target region.

[0161] The guidance cues in the illustrated embodiment include the center of the tumor marker **1412**, which can be manually placed by a user, and tumor boundary markers **1410** which indicates the extents or boundary of the tumor in two perpendicular planes. As described in greater detail above with reference to FIGS. **8**, **9**, and **10A-10D**, a user can mark and/or annotate images. The system **100** can store the emplacement information of the markers and annotations in the virtual 3D space.

[0162] The guidance cues in the illustrated embodiment also include draws bars **1408A-1408D**, which can be generated by the system after the user has marked the center of the tumor (or other point in the tumor) and the boundary of the tumor. The system can calculate the location of the draw bars based on the suggested placement of a medical device, the length of the exposed electrode of the medical device and/or different locations within the exposed electrode of the medical device (e.g., tip, center, and end).

[0163] In the illustrated embodiment, the draw bars include draw bar **1408A** between the end of the exposed electrode of the virtual medical device **1406** (when placed at the placement suggestion **1404A**) and the image **1402**, draw bar **1408B** between the center of the exposed electrode of the medical device **1406** (when placed at the placement suggestion **1404A**) and the center of the tumor marker **1412**, draw bar **1408C** between the tip of the virtual medical device **1406** (when placed at the placement suggestion **1404A**) and the image **1402**, and draw bar **1408D** parallel to the exposed electrode of the virtual medical device (when placed at the placement suggestion **1404A**), but running through the previously marked center of the tumor.

[0164] The draws bars **1408A-1408D** can show the user 1) if the exposed electrode is long enough to cover the extent/boundary of the tumor, 2) if the exposed electrode is centered with respect to the tumor, and 3) the distance between the tumor-center and the electrode. This distance can also be displayed numerically on the screen (not shown).

[0165] In addition, the system can display placement suggestions **1404A**, **1404B** for the medical devices. The system can generate the placement suggestions **1404A**, **1404B** and number of placement suggestions based on: 1) the distance between the first medical device (after placement) and the tumor-center 2) the length of the exposed electrodes of the medical devices, 3) a model of the ablation parameters of the medical device (e.g. a lookup table), 4) tumor size, etc. In illustrated example, the system suggests a configuration of two medical devices.

[0166] In the illustrated embodiment, the placement suggestions **1404A**, **1404B** are illustrated as faded virtual medical devices, however, it will be understood that other method can be used to provide the placement suggestions. For example, the placement suggestion **1404A**, **1404B** can be illustrated as lines, bars, cylinders, letters (e.g., X's), etc.

[0167] Furthermore, when the medical device **1406** is close to, or enters the predetermined area, the system can generate the virtual medical device **1406** and the user can guide the virtual medical device **1406** to the placement suggestion **1404A**. The system's proposed configuration can be repeatedly updated as the user manipulates the first medical device (still outside the patient), until she accepts the proposed position.

[0168] FIG. **14B** illustrates the content on a display **1400** in certain embodiments depicting manipulation of the second medical device in context with the target region. Here, the first medical device has already been placed as indicated by the location of the first virtual medical device **1406**, and the system provides the user with the placement suggestion **1404B** for the second medical device.

[0169] The second virtual medical device **1414** is in a vertical orientation, and the user manipulates the second medical device corresponding to the second virtual medical device **1414** (e.g., while it is outside the patient) such that the intersection indicator **1416** (described in FIGS. **12A** and **12B**) is co-located with the suggested intersection indicator **1420** that the system displays at the tip of the placement suggestion **1404B**. Once this is achieved, the second medical device will be lined up with its trajectory directly toward the placement suggestion **1404B**. The user can then push the second medical device into the patient tissue until the system displays the tip of the second virtual medical device **1414** at the suggested intersection indicator **1420**. To aid a user in the placement of the second virtual medical device, the system includes relative spatial indicators **1418** and trajectory indicators **1422**, as described in greater detail above with reference to FIGS. **12A-12D**.

Medical Device Guidance—Planning Routine

[0170] FIG. **15** is a flow diagram illustrative of an embodiment of a routine **1500** implemented by the system **100** to provide medical device placement guidance. The medical devices can include invasive medical devices, non-invasive medical devices, and/or medical imaging devices. In some embodiments, the medical devices include ablation and/or biopsy needles. One skilled in the relevant art will appreciate that the elements outlined for routine **1500** can be implemented by one or more computing devices/components that are associated with the system **100**, such as the position sensing units **110**, **140**, the image guidance unit **130**, surgical system **149**, and/or imaging unit **140**. Accordingly, routine **1500** has been logically associated as being generally performed by the system **100**. However, the following illustrative embodiment should not be construed as limiting.

[0171] At block **1502**, the system **100** receives emplacement information associated with a target region. The emplacement information associated with the target region can be based on a marker or annotation placed by a healthcare provider as described earlier with reference to FIGS. **8**, **9**, and **10A-10D**. The system can use the emplacement of the marker and/or annotation to determine the emplacement of the target region. In some embodiments, the emplacement information is received during a medical procedure. In certain embodiments, the emplacement information is received prior to a medical procedure.

[0172] At block **1504**, the system **100** determines a first position relative to the target region for a first medical device based at least on the emplacement information of the target region. As described in greater detail above with reference to FIGS. **14A** and **14B**, the system **100** can determine a suggested placement of a first medical device with respect to the target region. As described previously, the suggested placement can be based on the length of the exposed electrodes of the medical device a model of ablation parameters, tumor size, number of medical devices to be used, etc.

[0173] At block **1506**, the system **100** determines a second position relative to the target region for a second medical

device. As mentioned previously the second position can be based on the emplacement information of the target region, the emplacement information of the first position, and/or any one or any combination of the parameters described above with reference to FIGS. 14A and 14B.

[0174] At block 1508, the system 100 causes a display device to display the target region, as described in greater detail above with reference to FIGS. 14A and 14B. The display can be based on a calculated viewing angle in a virtual 3D space, described in greater detail above with reference to FIGS. 2, 5, and 12A-12D, of the target region.

[0175] At block 1510, the system 100 causes the display device to display a first position indicator. The system can cause the display device to display the first position indicator at the first position. As discussed previously with reference to FIGS. 14A and 14B, the first position indicator can be in the form of the first virtual medical device or some other graphical indicator. A user can use the first position indicator to place the first medical device.

[0176] As described in greater detail above with reference to FIGS. 13, 14A, and 14B, the system 100 can receive emplacement information of the first medical device, as illustrated at block 1512. At block 1514, the system 100 causes the display device to display a first virtual medical device corresponding to the first medical device based at least on the emplacement information of the first medical device, as also described in greater detail above with reference to FIGS. 13, 14A, and 14B.

[0177] Additional, fewer, or different blocks can be used to implement the routine 1500 without departing from the spirit and scope of the description. For example, any one or a combination of blocks 1516-1520 can be used as part of routine 1500.

[0178] Similar to blocks 1510-1514 described previously, the system can display a second position indicator, receive emplacement information for the second medical device and display a virtual second medical device, as illustrated at blocks 1516-1520, respectively.

[0179] Furthermore, in some embodiments and as described in greater detail above with reference to FIG. 14A and 14B, the system 100 can determine and display draw bars indicating the relative emplacement of the virtual medical devices and/or suggested placements of the virtual medical devices with the target region. In addition, as described in greater detail above, with reference to FIGS. 12A-12D, the system can cause the display device to display various guidance cues (e.g., trajectory indicators, intersection indicators, patient orientation indicators, medical provider location indicators, etc.). As also described in greater detail above, with reference to FIGS. 12A-12D, the system can identify one of the virtual medical devices or position indicators as the foundational medical device and calculate and display various distances between the first and second medical devices, the foundational plane and the medical devices, a target plane and a medical device, etc.

Previous Emplacement of a Medical Device

[0180] Referring back to FIG. 14A, FIG. 14A also provides a perspective view of an embodiment in which the location of a medical device that has been removed is shown. In this embodiment, the system receives emplacement information of a medical device within a predetermined area at a first time. In some embodiments the first time is during a medical procedure. Based on the emplacement

information, the system can display the medical device, as described previously. The system can also use emplacement information to determine when the medical device has been removed (or when a tracking unit associated with the medical device has been removed).

[0181] Typically, when a medical device is removed (or the associated tracking unit is removed), the corresponding virtual medical device is not shown on the display. However, in some embodiments, when a medical device is removed (or when a tracking unit associated with the medical device is removed), the system can display an altered image 1404B (e.g., a faded image) of the virtual medical device.

[0182] The system can use the emplacement information received at the first time to determine the emplacement of the altered image 1404B. In certain embodiments, the system displays the altered image 1404B at the location of the virtual medical device at the first time. Over time, as the location of the previously removed (or no longer tracked) medical device becomes less reliable (e.g., due to normal organ movement, etc.), the system can continue to alter the altered image 1404B, until it is removed. For example, the system can make the altered image 1404B more transparent over time (e.g., more faded).

[0183] In the interim, a user can use the altered image 1404B to place a second medical device 1406. For example, this can be done when a second biopsy is taken. The system can provide the user with the guidance cues described above with reference to FIGS. 2-12D to aid in the placement of the second medical device 1406. For example, the system can identify the altered image 1404B as a foundational medical device and the second medical device 1406 as a secondary medical device. Using this information, the system can calculate and display one or more guidance cues associated with the altered image 1404B, such as foundational plane indicators, foundational plane intersection indicators, relative spatial indicators, relative distances between portions the second medical device 1406 and the altered image 1404B, etc.

Previous Emplacement of a Medical Device Routine

[0184] FIG. 16 is a flow diagram illustrative of an embodiment of a routine 1600 implemented by the system 100 to display an altered image of a virtual medical device after a medical device has been removed from a predetermined area. One skilled in the relevant art will appreciate that the elements outlined for routine 1600 can be implemented by one or more computing devices/components that are associated with the system 100, such as the position sensing units 110, 140, the image guidance unit 130, surgical system 149, and/or imaging unit 150. Accordingly, routine 1600 has been logically associated as being generally performed by the system 100. However, the following illustrative embodiment should not be construed as limiting.

[0185] At block 1602, the system 100 receives emplacement information of a tracking unit associated with a medical device at a first time. As described in greater detail above with reference to block 1302 of FIG. 13, the system 100 can receive emplacement information of medical devices. In some embodiments, the first time is during a medical procedure, such as during an ablation or biopsy procedure. In certain embodiments, the first time is based on a user input. For example, a healthcare provider can indicate a certain time at which the system 100 is to receive and/or collect the emplacement information. To indicate the predetermined

time, the healthcare provider can touch a screen, click a button, or enter information into the system 100, etc.

[0186] At block 1604, the system 100 calculates a viewing angle of a virtual medical device in a virtual 3D space based at least on the emplacement information. As described in greater detail above with reference to block 1302 of FIG. 13, the system 100 can calculate the viewing angle of virtual medical devices using received emplacement information.

[0187] At block 1606, the system 100 causes a display device to display the virtual medical device based at least on the calculated viewing angle. As described in greater detail above with reference to block 1302 of FIG. 13, the system 100 can cause a display device to display a virtual medical device based on emplacement information of the corresponding medical device within a predetermined area. As mentioned previously, the predetermined area can correspond to a location of a medical procedure, the location of a patient, the location of tracking units, the range of position sensing units, a surgical table, an area corresponding to a virtual 3D area displayed on a display etc.

[0188] At block 1608, the system 100 determines that the tracking unit associated with the medical device has been removed from the predetermined area. As the system 100 receives emplacement information from the tracking unit, it can determine the location of the tracking unit and associated medical device. Further, it can determine when the tracking unit has left the predetermined area, such as the area corresponding to the virtual 3D space displayed by the display. To determine that the tracking unit has left the predetermined area, the system 100 can compare the emplacement information of the tracking unit with emplacement information of the predetermined area. When the tracking unit is outside the predetermined area, the system 100 can determine that the tracking unit has been removed from the predetermined area.

[0189] In some embodiments, the removal of the tracking unit from the predetermined area corresponds to the removal of the medical device from the predetermined area. In certain embodiments, the removal of the tracking unit from the predetermined area does not correspond to the removal of the medical device from the predetermined area. As described in greater detail above with reference to FIGS. 1A and 1B, in some embodiments, the tracking units can be removed from the medical device. For example, in some cases the tracking unit can be snapped on and/or off of a medical device. In certain embodiments, the tracking unit cannot be easily removed from the medical device. For example, in some cases, the tracking unit is embedded into the medical device or located at or near the tip of the medical device and is inserted into the patient. Accordingly, in some cases a tracking unit can be used with multiple medical devices. Thus, removal of the tracking unit can mean that the associated medical device has been removed or that it is no longer associated with the tracking unit.

[0190] At block 1610, the system 100 causes the display device to display an altered image of the virtual medical device based at least on the emplacement information received at the first time. Upon determining that the tracking unit has left the predetermined area, the system 100 can cause the display device to display an altered the image of the virtual medical device.

[0191] Typically, when a medical device is removed from the predetermined area, the corresponding virtual medical device is no longer displayed by the system 100. However,

in some cases it can be useful to identify where medical devices were located at a first time, such as during previous medical procedures (e.g., ablations, biopsies, etc.). Accordingly, in some embodiments, the system 100 can use the emplacement information received at the first time to display an altered image of the medical device on the display. In some embodiments, the virtual medical device is displayed at its previous location at the predetermined time. In certain embodiments, the system 100 can cause the virtual medical device to be faded or grayed out to indicate that it is no longer present.

[0192] Similarly, in cases where a tracking unit is removed from one medical device (or stops working) it can be useful to retain an image of the virtual medical device on the display. Accordingly, in some embodiments, the system 100 can use the emplacement information received during at the predetermined time to display an altered image of the medical device on the display. In some embodiments, the altered image of the virtual medical device is displayed at its last known location (based on the first time). In certain embodiments, the system 100 can cause the virtual medical device to be faded or grayed out to indicate that its location is no longer being tracked and/or may be unreliable.

[0193] Additional, fewer, or different blocks can be used to implement the routine 1600 without departing from the spirit and scope of the description. For example, the system can omit blocks 1604 and 1606 determine a previous placement of a medical device based on emplacement information received previously. Using that information, the system can cause the display device to display an altered image of the virtual medical device or can cause the display device to display the virtual medical device. Further, any one or a combination of blocks 1612-1020 can be used as part of routine 1600.

[0194] At block 1612, the system 100 further alters the image over time. Over time the reliability of the location of the altered virtual medical device will decrease. This can be due to normal organ movement of the patient or movement due to the healthcare provider. Accordingly, based at least on an amount of time that has passed since the first time, the system can further alter (e.g., fade or gray out) the altered virtual medical device. Thus, the altered virtual medical device can continue to fade until it is removed from the display (e.g., the system ceases to display the altered image), as illustrated at block 1614.

[0195] At block 1616, the system 100 can receive emplacement information of a tracking unit associated with a second medical device after causing the display device to display the altered image. In some embodiments, the second medical device is the same as the first medical device. For example, after the medical device has been removed from the predetermined area, the healthcare provider may reintroduce it at another location for another medical procedure. Accordingly, the system 100 can receive the new emplacement information of the tracking unit associated with the medical device. Based on the new emplacement information, the system 100 can calculate the new viewing angle of the virtual medical device in the virtual 3D space and cause the display to display it. However, as mentioned previously, the system 100 can retain the altered image as a reference for the healthcare provider.

[0196] Similarly, the system can receive emplacement information of a tracking unit (the same or different tracking unit from the one mentioned above with reference to block

1616) associated with a second medical device after causing the display device to display the altered image, as illustrated at block **1618**. The second medical device can be a different medical device with its own tracking unit or a different medical device using the same tracking unit as the first medical device. In either instance, the system **100** can receive the emplacement information of the second medical device (via the emplacement information of the tracking unit), calculate the viewing angle of the second virtual medical device in the virtual 3D space, and cause the display to display it. As mentioned previously, the system **100** can retain the altered image of the first virtual medical device on the display as a reference.

[0197] At block **1620**, the system **100** determines and displays one or more guidance cues associated with the altered image of the first virtual medical device, the first virtual medical device (based on new emplacement information), and/or the second virtual medical device. The guidance cues can be any one or more of the guidance cues described above with reference to FIGS. **2-12D**, **14A**, and **14B** (e.g., foundational plane indicators, intersection indicators, trajectories, ablation volumes, annotations, etc.). For example, the system can use the altered image of the first virtual medical device as the foundational medical device or as a secondary medical device in determining and displaying the guidance cues. As another example, the system can use the axis of the altered image as a target axis. In some embodiments, the system **100** can display the ablation volume of the altered image based on the volume that was ablated previously, etc.

Foundational Plane Plot

[0198] FIG. **17** is a diagram illustrative of an embodiment of a foundational plane plot **1702**, or needle tip map. In the illustrated embodiment, the distances between the tips of the needles, as well as the angles between their shafts can be displayed in the relative emplacement measurement display area **1206**. Furthermore, as described previously, the text can be white if it meets the requirement, and red if not. The needles can be represented by their number and color.

[0199] FIG. **17** further illustrates a foundational plane plot **1702** in the bottom left-hand corner. The foundational plane plot **1702** provides a visual indication of the distances between the tips of the needles from the point of view of the user looking “down” onto the foundation-tip-plane. In some embodiments, the location of the foundational needle tip can be the center of the tip map **1702**.

[0200] In the illustrated embodiment, dots **1712**, **1714**, **1716** (other marks can be used) are drawn at the real-time location of the tip of the foundational needle **1212**, as well as the relative location of the tips of the other needles **1214**, **1216**. In FIG. **17**, the foundational needle’s dot **1712** is drawn in the third color (approximate center of the tip map and bottom-most of the three tips), the dot **1714** for the tip of the second needle is drawn in the second color (middle tip of the three tips), and the dot **1716** for the third needle’s tip is drawn in the first color (top tip of the three tips). Looking at the needles’ locations in the 2D or 3D view, a user can confirm that the tips are in the correct arrangement in the foundational plane plot **1702**. Additionally, a grid can be drawn to give scale. In the illustrated embodiment, the grid marks **1704** are at 1 cm intervals, providing a visual cue to how far apart the needle tips are in reality. It will be understood that other intervals can be used as desired.

[0201] The needle-tip distances can be measured and displayed in different ways: For example, the needle-tip distances can be displayed as the actual 3D distances, and/or the distances in the foundational-tip-plane (which is to say, the lengths of the legs of the foundational plane indicators **1228**, **1230**). In some embodiments, the foundational-tip-plane is used when the secondary needles are parallel and level to the foundational needle.

[0202] Additionally, the foundational plane plot **1702** can be drawn such that if the user moves a needle closer to himself, the needle’s dot in the foundational plane plot **1702** will be seen moving lower on the screen, providing the user with intuitive feedback on how to place needles relative to each other.

Rotated View

[0203] FIG. **18A** and **18B** are diagrams illustrating embodiments of rotated views. In some instances when displaying 3D information on a 2D display, objects, such as needles in this example, can look parallel from a perspective 3D view in the 3D image display area **1204**, as illustrated in FIGS. **18A** and **18B**. However, looking from a different perspective would reveal that they are not parallel.

[0204] With reference to FIG. **18A**, from the point of view in the 3D image display area **1204**, the needles **1212**, **1216** appear parallel. To alleviate this issue, an alternate 2D view “from the side” can be provided in a second 2D image display area **1802**. The alternate 2D view can be drawn by rotating the typical 2D view in the 2D image display area **1202** by 90 degrees (or -90 degrees). It will be understood that other degrees can be used for the rotation as well. In some embodiments, this alternate 2D view in the second 2D image display area **1802** can be included in addition to the 2D view in the 2D image display area **1202**.

[0205] By rotating the point of view by 90 degrees (without moving the needles or transducer), it becomes obvious that the needle **1216** is not parallel to the foundational needle **1212**, as is indicated by the angle of 22 degrees in the emplacement measurement display area **1206**. Using this rotated point of view, the user can identify when the needles are not parallel, despite the image in the 3D image display area **1204** indicating that the needles are parallel.

[0206] With reference to FIG. **18B**, in some embodiments, an alternate 3D view in a second 3D image display area **1804** can be generated by rotating the typical 3D view in the 3D image display area **1204** by 90 degrees (or -90 degrees). It will be understood that other degrees can be used as well for the rotation. The alternate 3D view can be used to identify needles that are not in parallel despite the typical 3D view indicating that they are in parallel. The multiple perspectives can provide the user with increased confidence that the needles are parallel.

Example Embodiments

[0207] Various example embodiments of the disclosure can be described in view of the following clauses:

[0208] Clause 1. A system comprising:

[0209] a display; and

[0210] a computer system comprising a computer processor and memory and in communication with the display and a plurality of tracking units associated with a plurality of medical devices, wherein the computer system is configured to:

- [0211] receive emplacement information of at least a portion of the plurality of medical devices within a predetermined area;
- [0212] calculate a viewing angle in a virtual 3D space of a plurality of virtual medical devices corresponding to the plurality of medical devices based at least on the emplacement information of the plurality of medical devices; and
- [0213] cause the display to display the plurality of virtual medical devices based at least on the calculated viewing angle in the virtual 3D space.
- [0214] Clause 2. The system of Clause 1, wherein the plurality of medical devices are invasive medical devices.
- [0215] Clause 3. The system of any of Clauses 1 and 2, wherein the plurality of medical devices comprises a plurality of ablation needles.
- [0216] Clause 4. The system of any of Clauses 1-3, wherein the computer system is further configured to:
- [0217] calculate an ablation volume of each of the plurality of medical devices; and
- [0218] cause the display device to display the calculated ablation volume of each of the plurality of medical devices.
- [0219] Clause 5. The system of any of Clauses 1-4, wherein the computer system is further configured to:
- [0220] calculate a trajectory of each of the plurality of medical devices; and
- [0221] cause the display device to display the calculated trajectory of each of the plurality of medical devices.
- [0222] Clause 6. The system of any of Clauses 1-5, wherein the computer system is further configured to indicate an orientation of a patient with respect to a viewing reference of the image data in the virtual 3D space.
- [0223] Clause 7. The system of any of Clauses 6, wherein the computer system is further configured to indicate a location of a medical provider with respect to the patient in the virtual 3D space.
- [0224] Clause 8. The system of any of Clauses 1-7, wherein the computer system is further configured to:
- [0225] receive emplacement information of a medical imaging device within the predetermined area;
- [0226] receive image data based at least on the emplacement information of the medical imaging device;
- [0227] calculate a viewing angle in the virtual 3D space of the image data based at least on the emplacement information of the medical imaging device; and
- [0228] cause the display device to display the image data based at least on the calculated viewing angle in the virtual 3D space.
- [0229] Clause 9. The system of any of Clauses 1-8, wherein the image data is received from the medical imaging device.
- [0230] Clause 10. The system of Clause 9, wherein the medical imaging device comprises an ultrasound transducer and the image data comprises an ultrasound image.
- [0231] Clause 11. The system of any of Clauses 9 and 10, wherein the computer system is further configured to cause the display device to display a second set of the image data at a second location on the display device.
- [0232] Clause 12. The system of any of Clauses 9-11, wherein the computer system is further configured to:
- [0233] calculate an intersection between an image plane of the image data and a calculated trajectory of at least one medical device of the plurality of medical devices; and
- [0234] cause the display device to display an indication of the intersection of the image plane and the calculated trajectory of the at least one medical device.
- [0235] Clause 13. The system of any of Clauses 9-12, wherein the computer system is further configured to:
- [0236] calculate a viewing angle in the virtual 3D space of a virtual medical imaging device space corresponding to the medical imaging device based at least on the emplacement information of the medical imaging device; and
- [0237] cause the display device to display the virtual medical imaging device space based at least on the calculated viewing angle in the virtual 3D space.
- [0238] Clause 14. The system of any of Clauses 1-13, further wherein the computer system is further configured to identify a foundational medical device from the plurality of medical devices, wherein each of the plurality of medical devices comprises a first portion and a second portion.
- [0239] Clause 15. The system of Clause 14, wherein the first portion of each of the plurality of medical devices is a tip of the medical device and the second portion of each of the plurality of medical devices is an end of an electrode of the medical device distal to the tip of the medical device.
- [0240] Clause 16. The system of any of Clauses 14 and 15, wherein the computer system is further configured to:
- [0241] determine a first foundational plane based at least on a location of the first portion of the foundational medical device, wherein the first foundational plane is orthogonal to a trajectory of the foundational medical device and intersects with the first portion of the foundational medical device; and
- [0242] cause the display device to indicate the first foundational plane in the virtual 3D space.
- [0243] Clause 17. The system of Clause 16, wherein the computer system is further configured to:
- [0244] calculate a distance between the first foundational plane and the first portion of a medical device of the plurality of medical devices; and
- [0245] cause the display device to display the plurality of medical devices based at least in part on the calculated distance.
- [0246] Clause 18. The system of any of Clauses 16 and 17, wherein the computer system is further configured to:
- [0247] determine an intersection between the first foundational plane and a trajectory of one or more medical devices of the plurality of medical devices; and
- [0248] cause the display device to display an indication of the intersection of the first foundational plane and the trajectory of the one or more medical devices.

- [0249] Clause 19. The system of any of Clauses 16-18, wherein the computer system is further configured to:
- [0250] determine a second foundational plane based at least on a location of the second portion of the foundational medical device, wherein the second foundational plane is orthogonal to a trajectory of the foundational medical device and intersects with the second portion of the foundational medical device; and
- [0251] cause the display device to indicate the second foundational plane in the virtual 3D space.
- [0252] Clause 20. The system of any of Clauses 16-19, wherein the computer system is further configured to cause the display device to display a graphical indicator on the foundational plane from the first portion of the foundational medical device to a location on the foundational plane where the first portion of at least one other medical device of the plurality of medical devices is to be located.
- [0253] Clause 21. The system of any of Clauses 14-20, wherein the computer system is further configured to:
- [0254] calculate an angle difference between the foundational medical device and at least one other medical device of the plurality of medical devices; and
- [0255] cause the display device to display an indication of the calculated angle difference.
- [0256] Clause 22. The system of any of Clauses 14-21, wherein the computer system is further configured to cause the display device to display a plurality of graphical indicators indicating a distance between a plurality of portions of the foundational medical device and a plurality of portions of at least one other medical device of the plurality of medical devices.
- [0257] Clause 23. The system of any of Clauses 14-22, wherein the computer system is further configured to cause the display device to display a plurality of graphical indicators indicating a distance between at least one of a target axis and a target plane and a plurality of portions of at least one medical device of the plurality of medical devices.
- [0258] Clause 24. The system of any of Clauses 14-23, wherein the computer system is further configured to:
- [0259] calculate a distance between the first portion of the foundational medical device and the first portion of at least one other medical device of the plurality of medical devices based at least on the received emplacement information of at least a portion of the plurality of medical devices; and
- [0260] cause the display device to display an indication of the calculated distance.
- [0261] Clause 25. The system of any of Clauses 24, wherein the indication comprises at least one of a graphical indicator between the first portion of the foundational medical device and the first portion of the at least one other medical device and a number.
- [0262] Clause 26. The system of any of Clauses 1-25, further comprising the tracking units.
- [0263] Clause 27. The system of any of Clauses 1-26, further comprising the medical devices.
- [0264] Clause 28. A method, comprising:
- [0265] receiving emplacement information of a plurality of needles during a medical procedure of a patient;
- [0266] receiving emplacement information of a medical imaging device during the medical procedure;
- [0267] receiving at least one image from the medical imaging device; calculating a first viewing angle in a virtual 3D space of the at least one image based at least on the emplacement information of the medical imaging device with respect to a perspective view;
- [0268] calculating a second viewing angle in the virtual 3D space of a virtual medical imaging device corresponding to the medical imaging device based at least on the emplacement information of the medical imaging device with respect to the perspective view; p2 calculating a plurality of viewing angles in the virtual 3D space of a plurality of virtual needles corresponding to the plurality of needles based at least on the emplacement information of the plurality of needles with respect to the perspective view;
- [0269] causing the display device to display the at least one image based at least on the first calculated viewing angle in the virtual 3D space;
- [0270] causing the display device to display the virtual medical imaging device based at least on the second calculated viewing angle in the virtual 3D space; and
- [0271] causing a display device to display the plurality of virtual needles based at least on the plurality of calculated viewing angles in the virtual 3D space.
- [0272] Clause 29. A method, comprising
- [0273] receiving emplacement information of a plurality of medical devices within a predetermined area;
- [0274] calculating a viewing angle in a virtual 3D space of a plurality of virtual medical devices corresponding to the plurality of medical devices based at least on the emplacement information of the plurality of medical devices; and
- [0275] causing a display device to display the plurality of virtual medical devices based at least on the calculated viewing angle in the virtual 3D space.
- [0276] Clause 30. The method of Clause 29, wherein the plurality of medical devices are invasive medical devices.
- [0277] Clause 31. The method of any of Clauses 29 and 30, wherein the plurality of medical devices comprises a plurality of ablation needles.
- [0278] Clause 32. The method of any of Clauses 29-31, further comprising:
- [0279] calculating an ablation volume of each of the plurality of medical devices; and causing the display device to display the calculated ablation volume of each of the plurality of medical devices.
- [0280] Clause 33. The method of any of Clauses 29-32, further comprising:
- [0281] calculating a trajectory of each of the plurality of medical devices; and causing the display device to display the calculated trajectory of each of the plurality of medical devices.
- [0282] Clause 34. The method of any of Clauses 29-33, further comprising indicating an orientation of a patient with respect to a viewing reference of the image data in the virtual 3D space.

- [0283] Clause 35. The method of Clause 34, further comprising indicating a location of a medical provider with respect to the patient in the virtual 3D space.
- [0284] Clause 36. The method of any of Clauses 29-35, further comprising:
- [0285] receiving emplacement information of a medical imaging device within the predetermined area;
 - [0286] receiving image data based at least on the emplacement information of the medical imaging device;
- [0287] calculating a viewing angle in the virtual 3D space of the image data based at least on the emplacement information of the medical imaging device; and
- [0288] causing the display device to display the image data based at least on the calculated viewing angle in the virtual 3D space.
- [0289] Clause 37. The method of Clause 36, wherein the image data is received from the medical imaging device.
- [0290] Clause 38. The method of any of Clauses 35 or 37, wherein the medical imaging device comprises an ultrasound transducer and the image data comprises an ultrasound image.
- [0291] Clause 39. The method of any of Clauses 35-38, further comprising causing the display device to display a second set of the image data at a second location on the display device.
- [0292] Clause 40. The method of any of Clauses 35-39, further comprising:
- [0293] calculating an intersection between an image plane of the image data and a calculated trajectory of at least one medical device of the plurality of medical devices; and
 - [0294] causing the display device to display an indication of the intersection of the image plane and the calculated trajectory of the at least one medical device.
- [0295] Clause 41. The method of any of Clauses 35-40, further comprising:
- [0296] calculating a viewing angle in the virtual 3D space of a virtual medical imaging device space corresponding to the medical imaging device based at least on the emplacement information of the medical imaging device; and
 - [0297] causing the display device to display the virtual medical imaging device space based at least on the calculated viewing angle in the virtual 3D space.
- [0298] Clause 42. The method of any of Clauses 29-41, further comprising identifying a foundational medical device from the plurality of medical devices, wherein each of the plurality of medical devices comprises a first portion and a second portion.
- [0299] Clause 43. The method of Clause 42, wherein the first portion of each of the plurality of medical devices is a tip of the medical device and the second portion of each of the plurality of medical devices is an end of an electrode of the medical device distal to the tip of the medical device.
- [0300] Clause 44. The method of any of Clauses 42 and 43, further comprising:
- [0301] determining a first foundational plane based at least on a location of the first portion of the foundational medical device, wherein the first foundational plane is orthogonal to a trajectory of the foundational medical device and intersects with the first portion of the foundational medical device; and
- [0302] causing the display device to indicate the first foundational plane in the virtual 3D space.
- [0303] Clause 45. The method of Clause 44, further comprising:
- [0304] calculating a distance between the first foundational plane and the first portion of a medical device of the plurality of medical devices; and
 - [0305] causing the display device to display the plurality of medical devices based at least in part on the calculated distance.
- [0306] Clause 46. The method of any of Clauses 44 and 45, further comprising:
- [0307] determining an intersection between the first foundational plane and a trajectory of one or more medical devices of the plurality of medical devices; and
 - [0308] causing the display device to display an indication of the intersection of the first foundational plane and the trajectory of the one or more medical devices.
- [0309] Clause 47. The method of any of Clauses 44-46, further comprising:
- [0310] determining a second foundational plane based at least on a location of the second portion of the foundational medical device, wherein the second foundational plane is orthogonal to a trajectory of the foundational medical device and intersects with the second portion of the foundational medical device; and
 - [0311] causing the display device to indicate the second foundational plane in the virtual 3D space.
- [0312] Clause 48. The method of any of Clauses 44-47, further comprising causing the display device to display a graphical indicator on the foundational plane from the first portion of the foundational medical device to a location on the foundational plane where the first portion of at least one other medical device of the plurality of medical devices.
- [0313] Clause 49. The method of any of Clauses 42-48, further comprising:
- [0314] calculating an angle difference between the foundational medical device and at least one other medical device of the plurality of medical devices; and
 - [0315] causing the display device to display an indication of the calculated angle difference.
- [0316] Clause 50. The method of any of Clauses 42-49, further comprising causing the display device to display a plurality of graphical indicators indicating a distance between a plurality of portions of the foundational medical device and a plurality of portions of at least one other medical device of the plurality of medical devices.
- [0317] Clause 51. The method of any of Clauses 42-50, further comprising causing the display device to display a plurality of graphical indicators indicating a distance between at least one of a target axis and a target plane and a plurality of portions of at least one medical device of the plurality of medical devices.

- [0318] Clause 52. The method of any of Clauses 42-51, further comprising:
- [0319] calculating a distance between the first portion of the foundational medical device and the first portion of at least one other medical device of the plurality of medical devices based at least on the received emplacement information of at least a portion of the plurality of medical devices; and
- [0320] causing the display device to display an indication of the calculated distance.
- [0321] Clause 53. The method of any of Clauses 52, wherein the indication comprises at least one of a graphical indicator between the first portion of the foundational medical device and the first portion of the at least one other medical device and a number.
- [0322] Clause 54. A computer-readable, non-transitory storage medium having one or more computer-executable modules, the one or more computer-executable modules comprising:
- [0323] a first module in communication with a display and a plurality of tracking units associated with a plurality of medical devices, wherein the first module is configured to:
- [0324] receive emplacement information of at least a portion of the plurality of medical devices within a predetermined area;
- [0325] calculate a viewing angle in a virtual 3D space of a plurality of virtual medical devices corresponding to the plurality of medical devices based at least on the emplacement information of the plurality of medical devices; and
- [0326] cause the display to display the plurality of virtual medical devices based at least on the calculated viewing angle in the virtual 3D space.
- [0327] Clause 54. The computer-readably medium of Clause 54, wherein the one or more computer-executable modules are configured to perform any of, or any combination of, the steps recited in Clauses 29-53.
- [0328] Clause 55. A system comprising:
- [0329] a display; and
- [0330] a computer system comprising a computer processor and memory and in communication with the display and a tracking unit associated with a first medical device and, wherein the computer system is configured to:
- [0331] receive emplacement information of a target region;
- [0332] determine a first position relative to the target region for a first medical device based at least on the emplacement information of the target region;
- [0333] determine a second position relative to the target region for a second medical device based at least on the emplacement information of the target region;
- [0334] cause a display device to display the target region;
- [0335] cause the display device to display a first position indicator to indicate a suggested placement of the first medical device;
- [0336] receive emplacement information of the first medical device; and
- [0337] cause the display device to display a first virtual medical device corresponding to the first medical device based at least on the emplacement information of the first medical device.
- [0338] Clause 56. The system of Clause 55, further comprising the tracking unit.
- [0339] Clause 57. The system of any of Clauses 55 and 56, further comprising the first medical device and the second medical device.
- [0340] Clause 58. The system of any of Clauses 55-57, wherein the plurality of medical devices are invasive medical devices.
- [0341] Clause 59. The system of any of Clauses 55-58, wherein the plurality of medical devices comprises at least one of a plurality of ablation needles and a plurality of biopsy needles.
- [0342] Clause 60. The system of any of Clauses 55-59, wherein the computer system is further configured to:
- [0343] calculate a trajectory of each of the plurality of medical devices; and
- [0344] cause the display device to display the calculated trajectory of each of the plurality of medical devices.
- [0345] Clause 61. The system of any of Clauses 55-60, wherein the computer system is further configured to indicate an orientation of a patient with respect to a viewing reference of the image data in the virtual 3D space.
- [0346] Clause 62. The system of any of Clauses 61, wherein the computer system is further configured to indicate a location of a medical provider with respect to the patient in the virtual 3D space.
- [0347] Clause 63. The system of any of Clauses 55-62, wherein the computer system is further configured to:
- [0348] cause the display device to display a second position indicator to indicate a suggested placement of the second medical device;
- [0349] receive emplacement information of the second medical device; and
- [0350] cause the display device to display a second virtual medical device corresponding to the second medical device based at least on the emplacement information of the second medical device.
- [0351] Clause 64. The system of any of Clauses 55-63, wherein the computer system is further configured to:
- [0352] determine a distance between a portion of the target region and a portion of the first medical device;
- [0353] cause the display device to display a graphical indicator indicating the distance between the portion of the target region and the portion of the first medical device
- [0354] Clause 65. The system of any of Clauses 55-64 wherein the computer system is further configured to cause the display device to display a plurality of graphical indicators indicating a distance between at least one of a target axis and a target plane and a plurality of portions of at least one of the first medical device and the second medical device.
- [0355] Clause 66. A method for multi-needle image guided placement, comprising:
- [0356] receiving emplacement information of a target region during a medical procedure;
- [0357] determining a first suggested position relative to the target region for a first needle based at least on the emplacement information of the target region;

- [0358] determining a second suggested position relative to the target region for a second needle based at least on the emplacement information of the target region;
- [0359] causing a display device to display the target region;
- [0360] causing the display device to display a first position indicator at the first suggested position to indicate a suggested placement for the first needle;
- [0361] causing the display device to display a second position indicator at the second suggested position to indicate a suggested placement for second needle;
- [0362] receiving emplacement information of the first needle;
- [0363] causing the display device to display a first virtual needle corresponding to the first needle based at least on the emplacement information of the first needle;
- [0364] receiving emplacement information of the second needle; and
- [0365] causing the display device to display a second virtual needle corresponding to the second needle based at least on the emplacement information of the second needle.
- [0366] Clause 67. A method for multi-medical device image guided placement, comprising:
- [0367] receiving emplacement information of a target region;
- [0368] determining a first position relative to the target region for a first medical device based at least on the emplacement information of the target region;
- [0369] determining a second position relative to the target region for a second medical device based at least on the emplacement information of the target region;
- [0370] causing a display device to display the target region;
- [0371] causing the display device to display a first position indicator to indicate a suggested placement of the first medical device;
- [0372] receiving emplacement information of the first medical device; and
- [0373] causing the display device to display a first virtual medical device corresponding to the first medical device based at least on the emplacement information of the first medical device.
- [0374] Clause 68. The method of Clause 67, wherein the plurality of medical devices are invasive medical devices.
- [0375] Clause 69. The method of any of Clauses 67 and 68, wherein the plurality of medical devices comprises at least one of a plurality of ablation needles and a plurality of biopsy needles.
- [0376] Clause 70. The method of Clause 67-69, further comprising:
- [0377] calculating a trajectory of each of the plurality of medical devices; and causing the display device to display the calculated trajectory of each of the plurality of medical devices.
- [0378] Clause 71. The method of Clause 67-70, further comprising indicating an orientation of a patient with respect to a viewing reference of the image data in the virtual 3D space.
- [0379] Clause 72. The method of Clause 71, further comprising indicating a location of a medical provider with respect to the patient in the virtual 3D space.
- [0380] Clause 73. The method of any of Clauses 67-72, further comprising:
- [0381] causing the display device to display a second position indicator to indicate a suggested placement of the second medical device;
- [0382] receiving emplacement information of the second medical device; and
- [0383] causing the display device to display a second virtual medical device corresponding to the second medical device based at least on the emplacement information of the second medical device.
- [0384] The method of any of Clauses 1, further comprising:
- [0385] determining a distance between a portion of the target region and a portion of the first medical device;
- [0386] causing the display device to display a graphical indicator indicating the distance between the portion of the target region and the portion of the first medical device
- [0387] Clause 74. The method of any of Clauses 67-74, further comprising causing the display device to display a plurality of graphical indicators indicating a distance between at least one of a target axis and a target plane and a plurality of portions of at least one of the first medical device and the second medical device.
- [0388] Clause 75. A computer-readable, non-transitory storage medium having one or more computer-executable modules, the one or more computer-executable modules comprising:
- [0389] a first module in communication with a display and a tracking unit associated with a first medical device, wherein the first module is configured to:
- [0390] receive emplacement information of a target region;
- [0391] determine a first position relative to the target region for a first medical device based at least on the emplacement information of the target region;
- [0392] determine a second position relative to the target region for a second medical device based at least on the emplacement information of the target region;
- [0393] cause a display device to display the target region;
- [0394] cause the display device to display a first position indicator to indicate a suggested placement of the first medical device;
- [0395] receive emplacement information of the first medical device; and
- [0396] cause the display device to display a first virtual medical device corresponding to the first medical device based at least on the emplacement information of the first medical device.
- [0397] Clause 76. The computer-readably medium of Clause 75, wherein the one or more computer-executable modules are configured to perform any of, or any combination of, the steps recited in Clauses 67-73.

- [0398] Clause 77. A system comprising:
- [0399] a display;
 - [0400] a computer system comprising a computer processor and memory and in communication with the display and a tracking unit associated with a medical device, wherein the computer system is configured to:
 - [0401] receive emplacement information of a tracking unit within a predetermined area and associated with a medical device at a first time;
 - [0402] determine the tracking unit associated with the medical device has been removed from the predetermined area at a second time after the first time; and
 - [0403] cause the display device to display an altered image of a virtual medical device based at least on the emplacement information received at the first time.
- [0404] Clause 78. The system of Clause 77, wherein the computer system is further configured to:
- [0405] calculate a viewing angle in a virtual 3D space of a virtual medical device corresponding to the medical device based at least on the emplacement information;
 - [0406] cause a display device to display the virtual medical device based at least on the calculated viewing angle in the virtual 3D space;
- [0407] Clause 79. The system of any of Clauses 77 and 78, further comprising the tracking unit.
- [0408] Clause 80. The system of any of Clauses 77-79, further comprising the first medical device and the second medical device.
- [0409] Clause 81. The system of any of Clauses 77, wherein the computer system is further configured to further alter the altered image of the first virtual medical device based at least on an amount of time that has passed since the first time.
- [0410] Clause 82. The system of any of Clauses 77-81, wherein the computer system is further configured to cease display of the altered image once a threshold time is satisfied.
- [0411] Clause 83. The system of any of Clauses 77-82, wherein the virtual medical device is a first virtual medical device, the method wherein the computer system is further configured to:
- [0412] receive emplacement information of a tracking unit associated with a second medical device at a third time after the second time; and
 - [0413] calculate a second viewing angle in the virtual 3D space of a second virtual medical device based at least on the emplacement information received at the third time; and
 - [0414] cause the display device to display the second virtual medical device based at least on the second calculated viewing angle in the virtual 3D space, wherein the altered image of the virtual medical device is also displayed.
- [0415] Clause 84. The system of Clause 83, wherein the tracking unit associated with the first medical device and the tracking unit associated with the second medical device is the same.
- [0416] Clause 85. The system of any of Clauses 83 and 84, wherein the second virtual medical device corresponds to a second medical device that is different from the first medical device.
- [0417] Clause 86. The system of any of Clauses 83-85, wherein the second virtual medical device corresponds to the first medical device.
- [0418] Clause 87. The system of any of Clauses 83-86, wherein the computer system is further configured to cause the display device to display a plurality of graphical indicators indicating a distance between at least one of a target axis and a target plane and a plurality of portions of the second virtual medical device.
- [0419] Clause 88. The system of any of Clauses 87, wherein the target axis is the axis of the altered image of the first virtual medical device.
- [0420] Clause 89. The system of any of Clauses 83-88, wherein the computer system is further configured to cause the display device to display a plurality of graphical indicators indicating a distance between a plurality of portions of the altered image of the first virtual medical device and a plurality of portions of the second virtual medical device.
- [0421] Clause 90. The system of any of Clauses 83-89, wherein the computer system is further configured to:
- [0422] calculate a distance between a first portion of the altered image of the first medical device and a first portion of the second virtual medical device based at least on the received emplacement information at the first time and the received emplacement information at the third time; and
 - [0423] cause the display device to display an indication of the calculated distance.
- [0424] Clause 91. A method, comprising
- [0425] receiving emplacement information of a first needle within a predetermined area during a first medical procedure;
 - [0426] calculating a first viewing angle in a virtual 3D space of a first virtual needle corresponding to the first needle based at least on the emplacement information of the first needle;
 - [0427] causing a display device to display the first virtual needle based at least on the first calculated viewing angle in the virtual 3D space;
 - [0428] determining the first needle is removed from the predetermined area after the first medical procedure;
 - [0429] causing the display device to display an altered image of the first virtual needle based at least on the emplacement information received during the first medical procedure and on an amount of time that has passed since the first medical procedure;
 - [0430] receiving emplacement information of a second needle after the first medical procedure and prior to a second medical procedure;
 - [0431] calculating a viewing angle in the virtual 3D space of a second virtual needle corresponding to the second needle based at least on the emplacement information of the second needle; and
 - [0432] causing the display device to display the second virtual needle based at least on the second calculated viewing angle in the virtual 3D space, wherein at least for a time period the altered image

- of the first virtual needle is displayed simultaneously with the second virtual needle.
- [0433] Clause 92. A method, comprising
- [0434] receiving emplacement information of a tracking unit associated with a medical device at a first time;
- [0435] calculating a viewing angle in a virtual 3D space of a virtual medical device corresponding to the medical device based at least on the emplacement information;
- [0436] causing a display device to display the virtual medical device based at least on the calculated viewing angle in the virtual 3D space;
- [0437] determining the tracking unit associated with the medical device has been removed from the predetermined area at a second time after the first time;
- [0438] causing the display device to display an altered image of the virtual medical device based at least on the emplacement information received at the first time.
- [0439] Clause 93. The method of Clause 92, further comprising further altering the altered image of the first virtual medical device based at least on an amount of time that has passed since the first time.
- [0440] Clause 94. The method of any of Clauses 92 and 93, further comprising ceasing display of the altered image once a threshold time is satisfied.
- [0441] Clause 95. The method of any of Clauses 92-94, wherein the virtual medical device is a first virtual medical device, the method further comprising:
- [0442] receiving emplacement information of a tracking unit associated with a second medical device at a third time after the second time; and
- [0443] calculating a second viewing angle in the virtual 3D space of a second virtual medical device based at least on the emplacement information received at the third time; and
- [0444] causing the display device to display the second virtual medical device based at least on the second calculated viewing angle in the virtual 3D space, wherein the altered image of the virtual medical device is also displayed.
- [0445] Clause 96. The method of Clause 95, wherein the tracking unit associated with the first medical device and the tracking unit associated with the second medical device is the same.
- [0446] Clause 97. The method of any of Clauses 95 and 96, wherein the second virtual medical device corresponds to a second medical device that is different from the first medical device.
- [0447] Clause 98. The method of any of Clauses 95-97, wherein the second virtual medical device corresponds to the first medical device.
- [0448] Clause 99. The method of any of Clauses 95-98, further comprising causing the display device to display a plurality of graphical indicators indicating a distance between at least one of a target axis and a target plane and a plurality of portions of the second virtual medical device.
- [0449] Clause 100. The method of Clause 99, wherein the target axis is the axis of the altered image of the first virtual medical device.
- [0450] Clause 101. The method of any of Clauses 95-100, further comprising causing the display device to display a plurality of graphical indicators indicating a distance between a plurality of portions of the altered image of the first virtual medical device and a plurality of portions of the second virtual medical device.
- [0451] Clause 102. The method of any of Clauses 95-101, further comprising:
- [0452] calculating a distance between a first portion of the altered image of the first medical device and a first portion of the second virtual medical device based at least on the received emplacement information at the first time and the received emplacement information at the third time; and
- [0453] causing the display device to display an indication of the calculated distance.
- [0454] Clause 103. A computer-readable, non-transitory storage medium having one or more computer-executable modules, the one or more computer-executable modules comprising:
- [0455] a first module in communication with a display and a tracking unit associated with a medical device, wherein the first module is configured to:
- [0456] receive emplacement information of a tracking unit associated with a medical device at a first time;
- [0457] calculate a viewing angle in a virtual 3D space of a virtual medical device corresponding to the medical device based at least on the emplacement information;
- [0458] cause a display device to display the virtual medical device based at least on the calculated viewing angle in the virtual 3D space;
- [0459] determine the tracking unit associated with the medical device has been removed from the predetermined area at a second time after the first time;
- [0460] cause the display device to display an altered image of the virtual medical device based at least on the emplacement information received at the first time.
- [0461] Clause 104. The computer-readable medium of Clause 103, wherein the one or more computer-executable modules are configured to perform any of, or any combination of, the steps recited in Clauses 93-102.
- [0462] Clause 105. A method, comprising
- [0463] receiving emplacement information of a tracking unit associated with a medical device at a first time;
- [0464] determining the tracking unit associated with the medical device has been removed from the predetermined area at a second time after the first time; and
- [0465] causing the display device to display an altered image of a virtual medical device based at least on the emplacement information received at the first time.

Terminology

[0466] Those having skill in the art will further appreciate that the various illustrative logical blocks, modules, circuits, and process steps described in connection with the implementations disclosed herein can be implemented as electronic hardware, computer software, or combinations of

both. To clearly illustrate this interchangeability of hardware and software, various illustrative components, blocks, modules, circuits, and steps have been described above generally in terms of their functionality. Whether such functionality is implemented as hardware or software depends upon the particular application and design constraints imposed on the overall system. Skilled artisans can implement the described functionality in varying ways for each particular application, but such implementation decisions should not be interpreted as causing a departure from the scope of the present invention. One skilled in the art will recognize that a portion, or a part, can comprise something less than, or equal to, a whole. For example, a portion of a collection of pixels can refer to a sub-collection of those pixels.

[0467] The various illustrative logical blocks, modules, and circuits described in connection with the implementations disclosed herein can be implemented or performed with a general purpose processor, a digital signal processor (DSP), an application specific integrated circuit (ASIC), a field programmable gate array (FPGA) or other programmable logic device, discrete gate or transistor logic, discrete hardware components, or any combination thereof designed to perform the functions described herein. A general purpose processor can be a microprocessor, but in the alternative, the processor can be any conventional processor, controller, microcontroller, or state machine. A processor can also be implemented as a combination of computing devices, e.g., a combination of a DSP and a microprocessor, a plurality of microprocessors, one or more microprocessors in conjunction with a DSP core, or any other such configuration.

[0468] The steps of a method or process described in connection with the implementations disclosed herein can be embodied directly in hardware, in a software module executed by a processor, or in a combination of the two. A software module can reside in RAM memory, flash memory, ROM memory, EPROM memory, EEPROM memory, registers, hard disk, a removable disk, a CD-ROM, or any other form of non-transitory storage medium known in the art. An exemplary computer-readable storage medium is coupled to the processor such the processor can read information from, and write information to, the computer-readable storage medium. In the alternative, the storage medium can be integral to the processor. The processor and the storage medium can reside in an ASIC. The ASIC can reside in a user terminal, camera, or other device. In the alternative, the processor and the storage medium can reside as discrete components in a user terminal, camera, or other device.

[0469] Headings are included herein for reference and to aid in locating various sections. These headings are not intended to limit the scope of the concepts described with respect thereto. Such concepts can have applicability throughout the entire specification.

[0470] The previous description of the disclosed implementations is provided to enable any person skilled in the art to make or use the present invention. Various modifications to these implementations will be readily apparent to those skilled in the art, and the generic principles defined herein can be applied to other implementations without departing from the spirit or scope of the invention. Thus, the present invention is not intended to be limited to the implementations shown herein but is to be accorded the widest scope

consistent with the principles and novel features disclosed herein.

1-20. (canceled)

21. A method, comprising:

determining an emplacement of a first virtual medical device based at least in part on received first emplacement data associated with a first medical device, wherein the first medical device comprises a first medical needle;

determining an emplacement of a second virtual medical device based at least in part on received second emplacement data associated with a second medical device, wherein the second medical device comprises a second medical needle that is different from the first medical needle;

receiving emplacement information associated with a targeted region, wherein the targeted region corresponds to at least one of a marker or annotation of a user;

determining a first suggested placement relative to the targeted region for the first virtual medical device based at least in part on the received emplacement information associated with the targeted region; and

determining a second suggested placement relative to the targeted region for the second virtual medical device based at least in part on the received emplacement information associated with the targeted region;

causing a display to concurrently display a perspective view of:

at least a portion of the targeted region based at least in part on the received emplacement information associated with the targeted region,

a 3D rendering of at least a portion of the first virtual medical device based at least in part on the determined emplacement of the first virtual medical device,

a 3D rendering of at least a portion of the second virtual medical device based at least in part on the determined emplacement of the second virtual medical device,

a first pose indicator indicative of the first suggested placement relative to the targeted region of the first virtual medical device, and

a second pose indicator indicative of the second suggested placement relative to the targeted region of the second virtual medical device.

22. A method, comprising:

receiving emplacement information associated with a region of interest;

determining a suggested placement relative to the region of interest for a medical device based at least in part on the emplacement information associated with the region of interest; and

causing a display to concurrently display a perspective view of:

at least a portion of the region of interest based at least in part on the emplacement information associated with the region of interest, and

a pose indicator indicative of the suggested placement for the medical device.

23. The method of claim **22**, further comprising:

receiving emplacement information associated with the medical device; and

- causing the display to further concurrently display a perspective view of a 3D rendering of at least a portion of a virtual medical device based at least in part on the emplacement information associated with the medical device.
- 24.** The method of claim **23**, further comprising:
calculating a trajectory of the medical device based at least in part on the emplacement of the medical device;
and
causing the display to further concurrently display a trajectory indicator indicative of the calculated trajectory of the medical device.
- 25.** The method of claim **22**, wherein the pose indicator comprises at least a portion of a virtual medical device that corresponds to the medical device.
- 26.** The method of claim **22**, wherein the medical device is a first medical device, the suggested placement is a first suggested placement, and the pose indicator is a first pose indicator, the method further comprising:
determining a second suggested placement relative to the region of interest for a second medical device based at least in part on the emplacement information associated with the region of interest; and
causing the display to further concurrently display a perspective view of a second pose indicator indicative of the second suggested placement for the second medical device.
- 27.** The method of claim **22**, wherein the medical device comprises at least one of a biopsy needle, an ablation needle, a surgical needle, a nerve-block needle, an electrocautery device, a catheter, a stent, a laparoscopic camera, or an ultrasound transducer.
- 28.** The method of claim **22**, wherein the region of interest corresponds to at least one of a marker or annotation within a virtual 3D scene.
- 29.** The method of claim **22**, further comprising:
causing the display to further concurrently display at least one guidance cue based at least in part on at least one of the region of interest or the suggested placement for the medical device.
- 30.** The method of claim **22**, further comprising:
determining a distance between a portion of the region of interest and a portion of the medical device; and
causing the display to further concurrently display a graphical indicator indicating the distance between the portion of the region of interest and the portion of the medical device.
- 31.** The method of claim **22**, wherein said determining the suggested placement of the medical device is further based at least in part on at least one of a target volume, one or more parameters of the medical device, or a model of ablation or biopsy parameters.
- 32.** The method of claim **22**, wherein said causing the display to concurrently display a perspective view of the pose indicator is further based at least in part on a determination that the medical device is within a predetermined area corresponding to a distance between the medical device and the region of interest.
- 33.** Non-transitory computer-readable media storing computer executable instructions that when executed by one or more processors cause the one or more processors to:
receive emplacement information associated with a region of interest;
determine a position relative to the region of interest for a medical device based at least in part on the emplacement information associated with the region of interest;
determine a suggested placement of the medical device based at least in part on the emplacement information associated with the region of interest; and
cause a display to concurrently display a perspective view of:
at least a portion of the region of interest based at least in part on the emplacement information associated with the region of interest, and
a pose indicator indicative of the suggested placement for the medical device based at least in part on the determined position of the medical device.
- 34.** The non-transitory computer-readable media of claim **33**, wherein the computer-executable instructions, when executed, further cause the one or more processors to:
receive emplacement information associated with the medical device; and
cause the display to further concurrently display a perspective view of a 3D rendering of at least a portion of a virtual medical device based at least in part on the emplacement of the medical device.
- 35.** The non-transitory computer-readable media of claim **33**, wherein the computer-executable instructions, when executed, further cause the one or more processors to:
calculate a trajectory of the medical device based at least in part on the emplacement of the medical device; and
cause the display to further concurrently display a trajectory indicator indicative of the calculated trajectory of the medical device.
- 36.** The non-transitory computer-readable media of claim **33**, wherein the medical device is a first medical device, the suggested placement is a first suggested placement, and the pose indicator is a first pose indicator, and wherein the computer-executable instructions, when executed, further cause the one or more processors to:
determine a second suggested placement relative to the region of interest for a second medical device based at least in part on the emplacement information associated with the region of interest; and
cause the display to further concurrently display a perspective view of a second pose indicator indicative of the second suggested placement for the second medical device.
- 37.** The non-transitory computer-readable media of claim **33**, wherein the computer-executable instructions, when executed, further cause the one or more processors to:
determine a distance between a portion of the region of interest and a portion of the medical device; and
cause the display to further concurrently display a graphical indicator indicating the distance between the portion of the region of interest and the portion of the medical device.
- 38.** A system, comprising:
one or more processors communicatively coupled to a display, the one or more processors configured to:
receive emplacement information associated with a region of interest;
determine a suggested placement of the medical device based at least in part on the emplacement information associated with the region of interest; and

cause a display to concurrently display a perspective view of:

at least a portion of the region of interest based at least in part on the emplacement information associated with the region of interest, and a pose indicator indicative of the suggested placement for the medical device based at least in part on the determined position of the medical device.

39. The system of claim **38**, wherein the one or more processors are further configured to:

receive emplacement information associated with the medical device; and

cause the display to further concurrently display a perspective view of a 3D rendering of at least a portion of a virtual medical device based at least in part on the emplacement information associated with the medical device.

40. The system of claim **38**, wherein the medical device is a first medical device, the suggested placement is a first suggested placement, and the pose indicator is a first pose indicator, and wherein the one or more processors are further configured to:

determine a second suggested placement relative to the region of interest for a second medical device based at least in part on the emplacement information associated with the region of interest; and

cause the display to further concurrently display a perspective view of a second pose indicator indicative of the second suggested placement for the second medical device.

* * * * *

专利名称(译)	多种医疗设备指导		
公开(公告)号	US20180289344A1	公开(公告)日	2018-10-11
申请号	US15/799639	申请日	2017-10-31
[标]申请(专利权)人(译)	INNEROPTIC TECH		
申请(专利权)人(译)	INNEROPTIC TECHNOLOGY , INC.		
当前申请(专利权)人(译)	INNEROPTIC TECHNOLOGY , INC.		
[标]发明人	GREEN CAROLINE HEANEY BRIAN RAZZAQUE SHARIF STATE ANDREI		
发明人	GREEN, CAROLINE HEANEY, BRIAN RAZZAQUE, SHARIF STATE, ANDREI		
IPC分类号	A61B6/12 A61B34/10 A61B17/32 A61B90/00 A61B18/14 A61B1/04 A61B1/303 A61B1/313 A61B5/00 A61B5/04 A61B6/00 A61B5/06 A61B8/08 A61B18/18 A61B17/221 A61B34/20 A61B5/055 A61B6/03 A61B8/00 A61B8/12 A61B17/34 A61B18/00 A61B18/20		
CPC分类号	A61B5/7425 A61B5/743 A61B6/12 A61B17/3403 A61B2018/143 A61B2018/1425 A61B2018/00577 A61B5/7475 A61B5/742 A61B5/72 A61B5/04 A61B5/0066 A61B1/3132 A61B1/303 A61B1/04 A61B6 /468 A61B8/468 A61B18/20 A61B18/1815 A61B6/037 A61B18/14 A61B8/12 A61B8/4483 A61B5/6848 A61B6/5223 A61B8/523 A61B8/483 A61B8/466 A61B6/466 A61B6/032 A61B5/055 A61B5/062 A61B8 /0841 A61B17/221 A61B17/320016 A61B34/20 A61B2090/378 A61B2034/107 A61B34/10 A61B90/361 A61B2018/1861 A61B2018/00559 A61B6/463		
优先权	61/736789 2012-12-13 US 61/592531 2012-01-30 US		
外部链接	Espacenet USPTO		

摘要(译)

一种用于提供用于将一个或多个医疗设备放置在目标位置的图像引导的系统和方法。该系统接收预定区域内的医疗设备的安置信息。系统计算与多个医疗设备对应的多个虚拟医疗设备的虚拟3D空间中的视角。该系统还使显示设备至少基于所计算的视角来显示多个虚拟医疗设备。

