



US 20140277384A1

(19) **United States**

(12) **Patent Application Publication**  
**Melsheimer**

(10) **Pub. No.: US 2014/0277384 A1**

(43) **Pub. Date: Sep. 18, 2014**

(54) **MEDICAL DEVICE WITH SELECTIVE RIGIDITY**

**Publication Classification**

(71) Applicant: **Cook Medical Technologies LLC**,  
Bloomington, IN (US)

(51) **Int. Cl.**  
*A61B 17/02* (2006.01)  
*A61F 2/82* (2006.01)

(72) Inventor: **Jeffrey S. Melsheimer**, Springville, IN  
(US)

(52) **U.S. Cl.**  
CPC ..... *A61B 17/0218* (2013.01); *A61F 2/82*  
(2013.01); *A61B 2017/0225* (2013.01)

(73) Assignee: **Cook Medical Technologies LLC**,  
Bloomington, IN (US)

USPC ..... **623/1.18**; 600/207; 600/204; 600/37

(21) Appl. No.: **14/203,007**

(57) **ABSTRACT**

(22) Filed: **Mar. 10, 2014**

A device for obtaining selective rigidity with respect to a patient is provided. The device includes a scaffold that is arranged to be flexible when in a first relaxed configuration, wherein the scaffold is configured to become substantially more rigid when a suction force is applied thereto. The scaffold comprises first and second opposing outer flexible layers that are sealed together to form a plurality of elongate pockets therein, and an expanded structure disposed within the plurality of elongate pockets and in communication with a vacuum port that receives the suction force.

**Related U.S. Application Data**

(60) Provisional application No. 61/791,561, filed on Mar. 15, 2013.

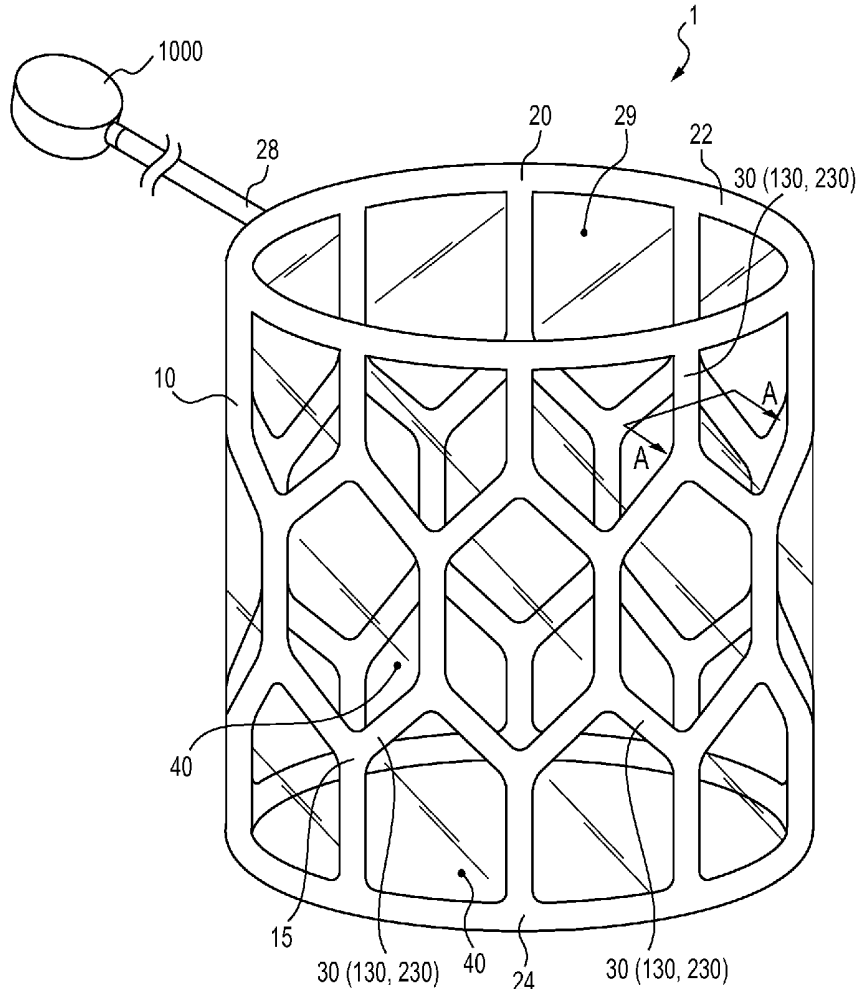

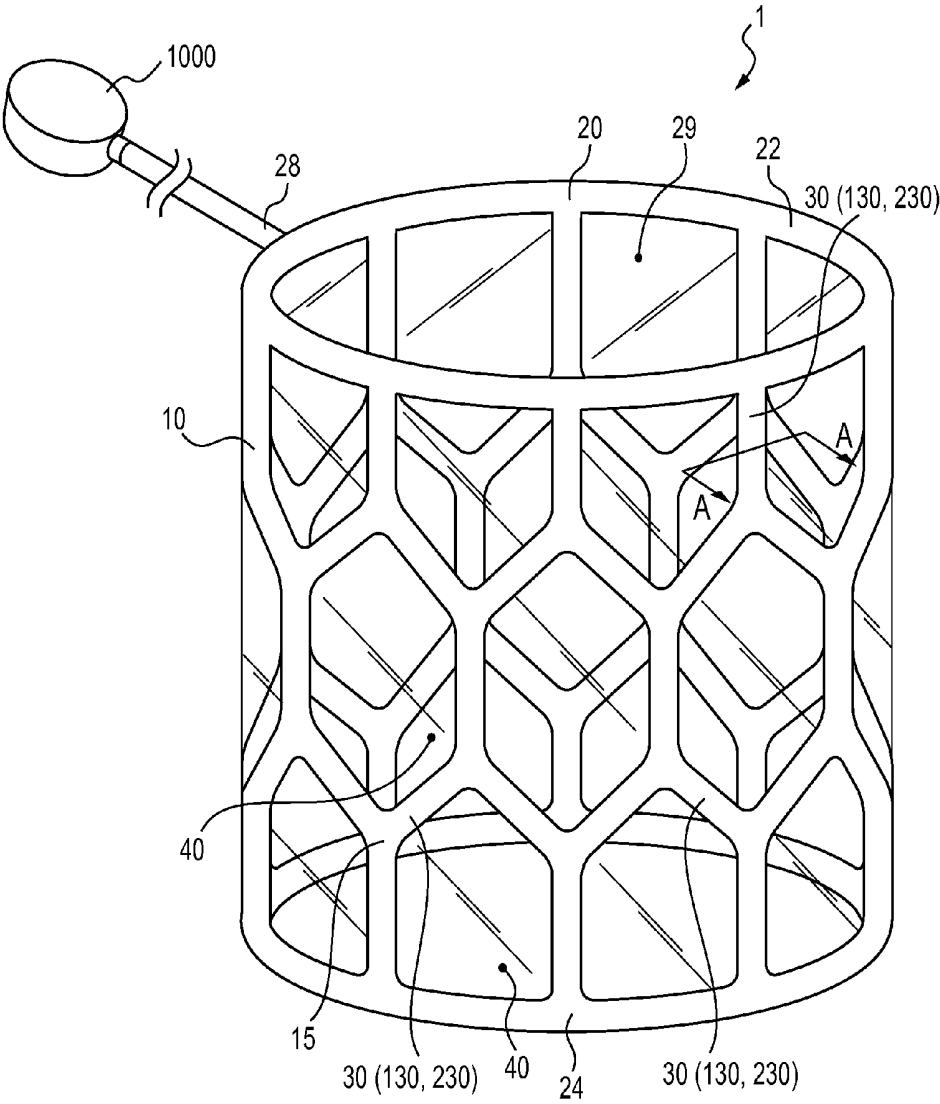

FIG. 1

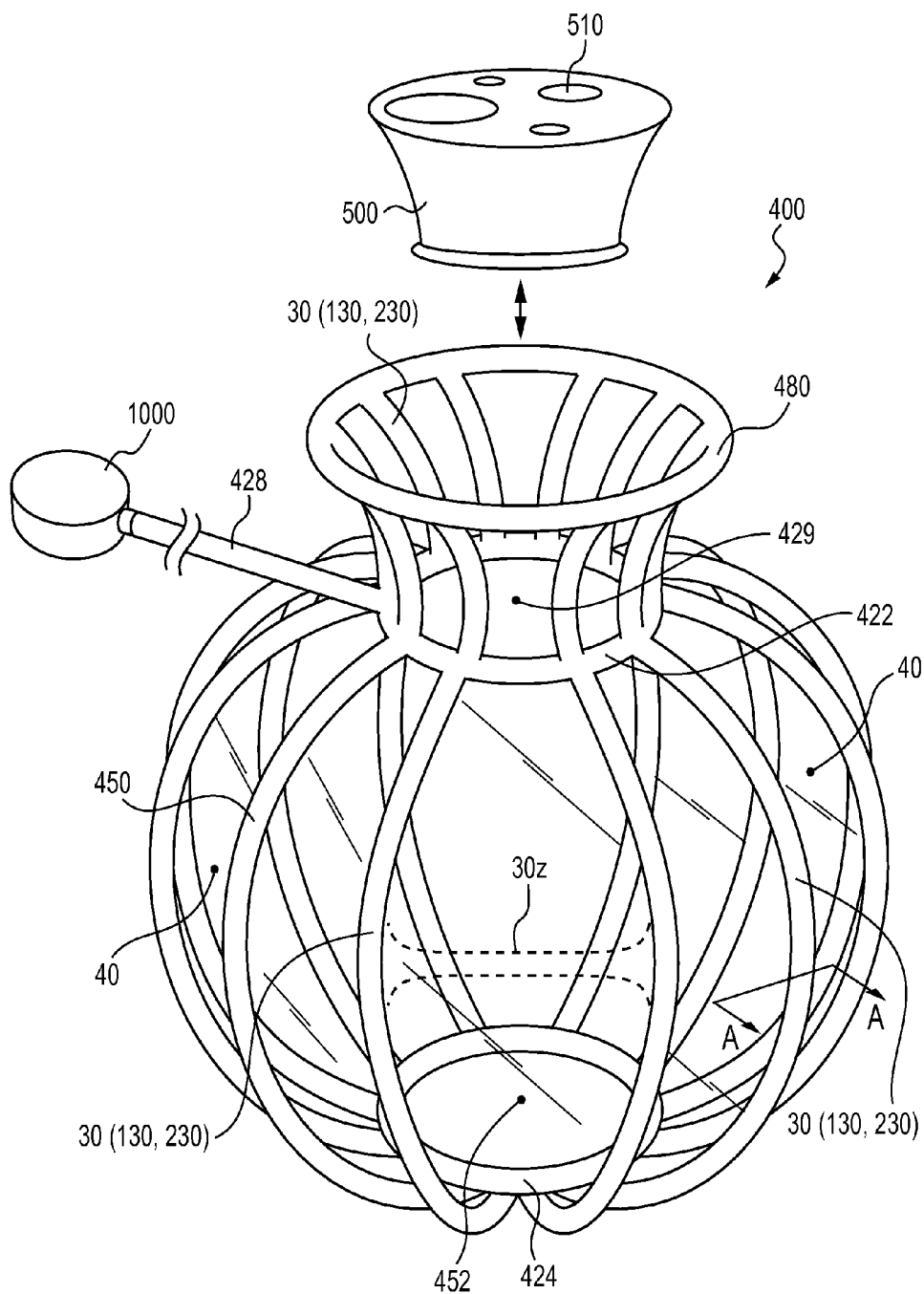

FIG. 2

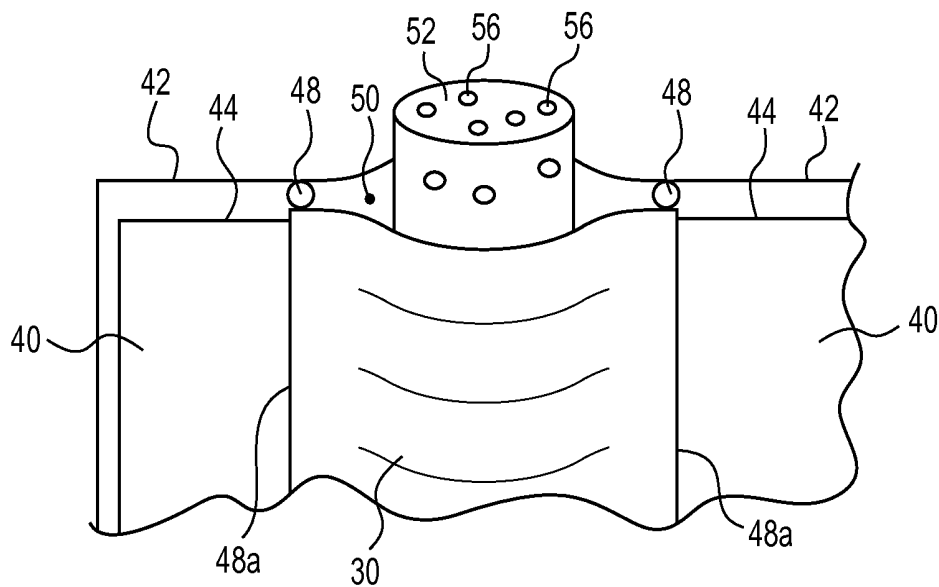

FIG. 3A

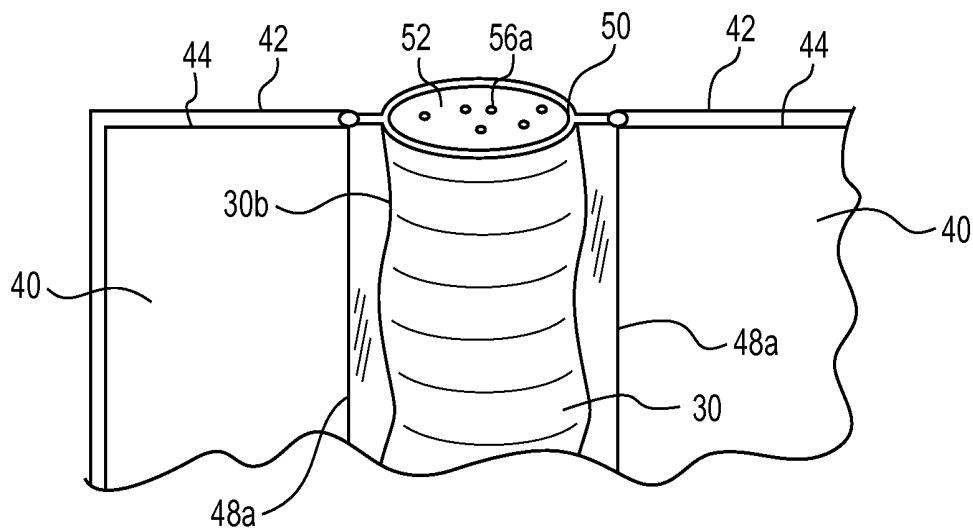

FIG. 3B

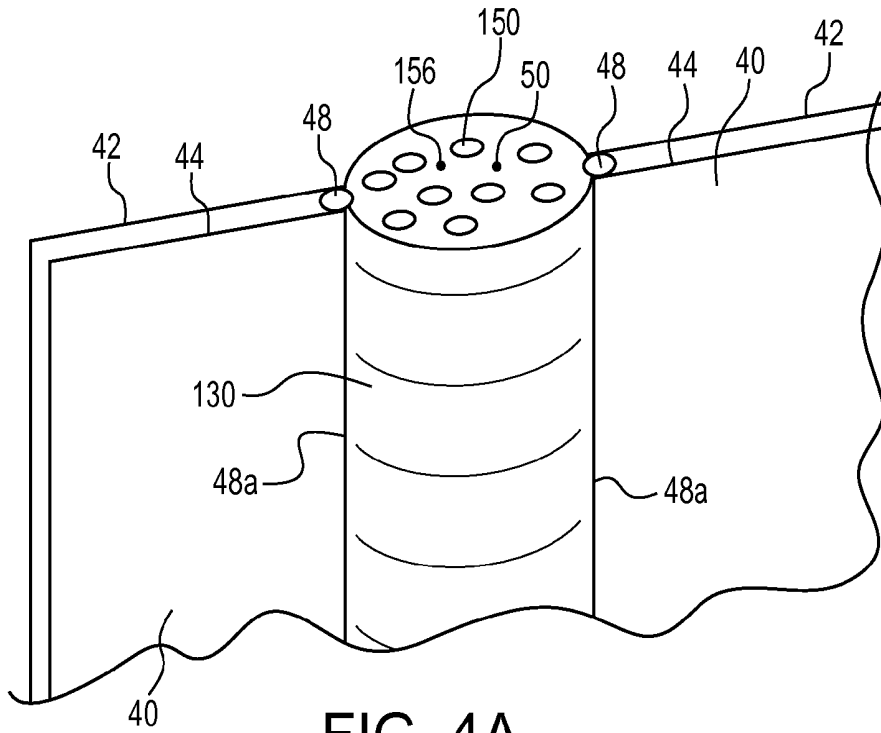

FIG. 4A

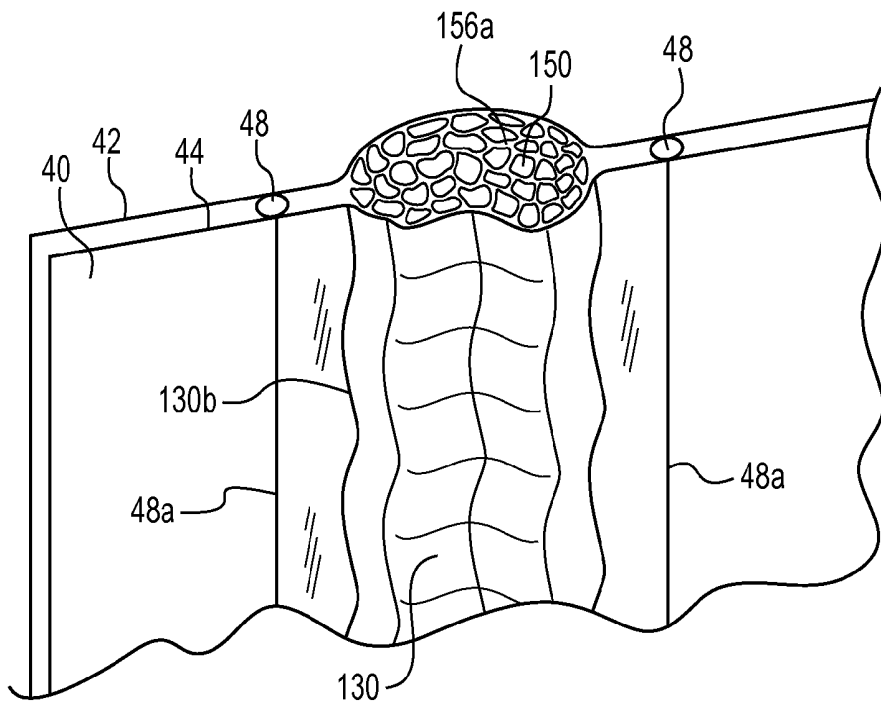

FIG. 4B

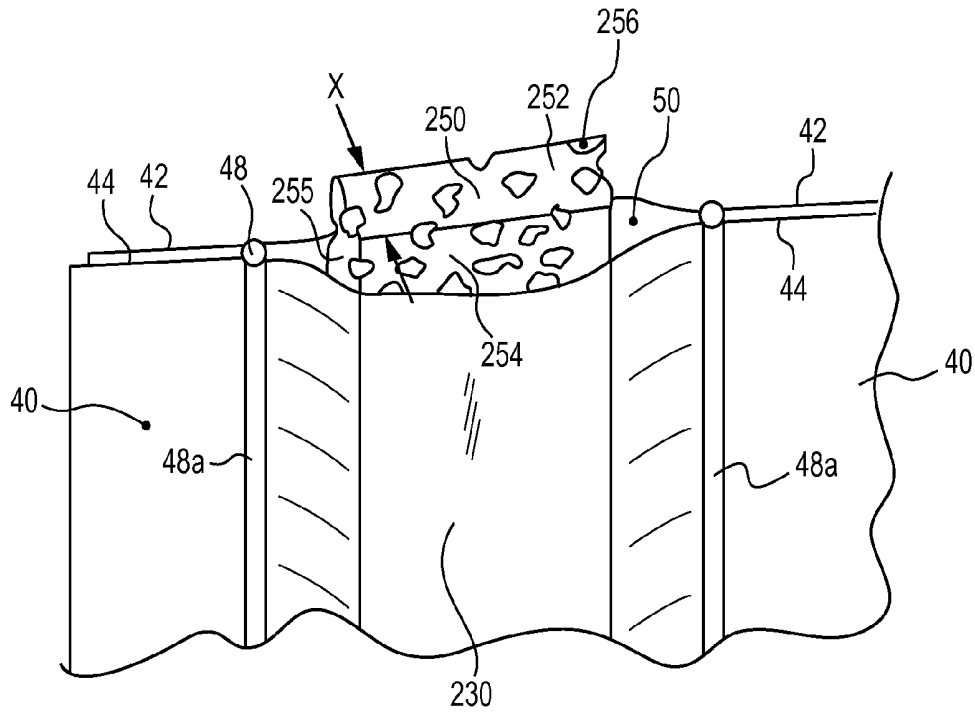

FIG. 5A

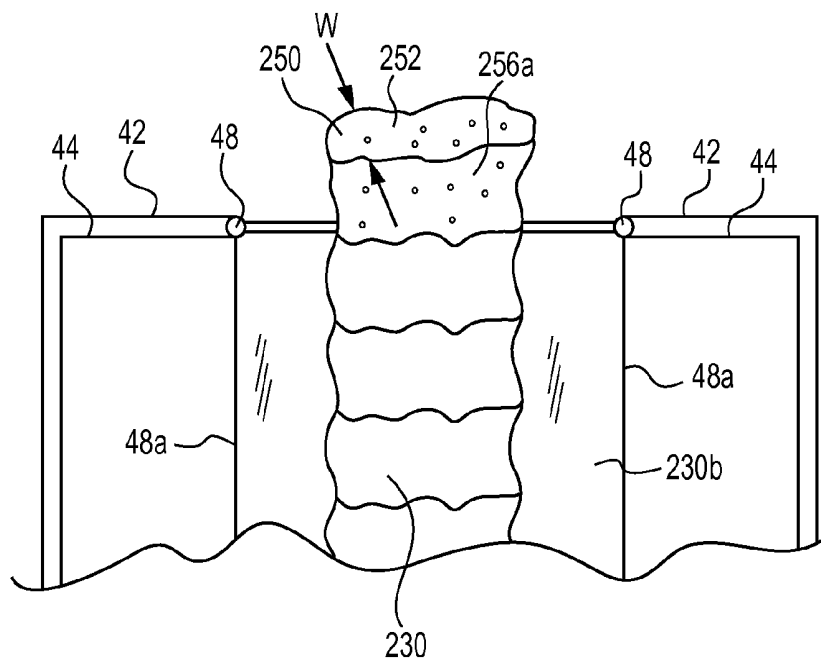

FIG. 5B

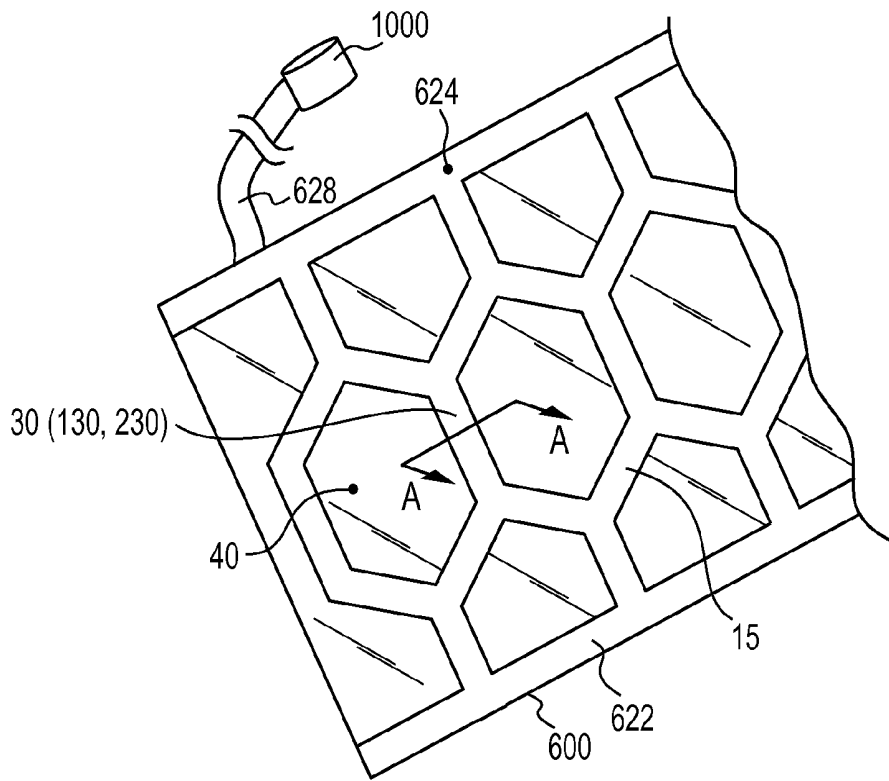

FIG. 6

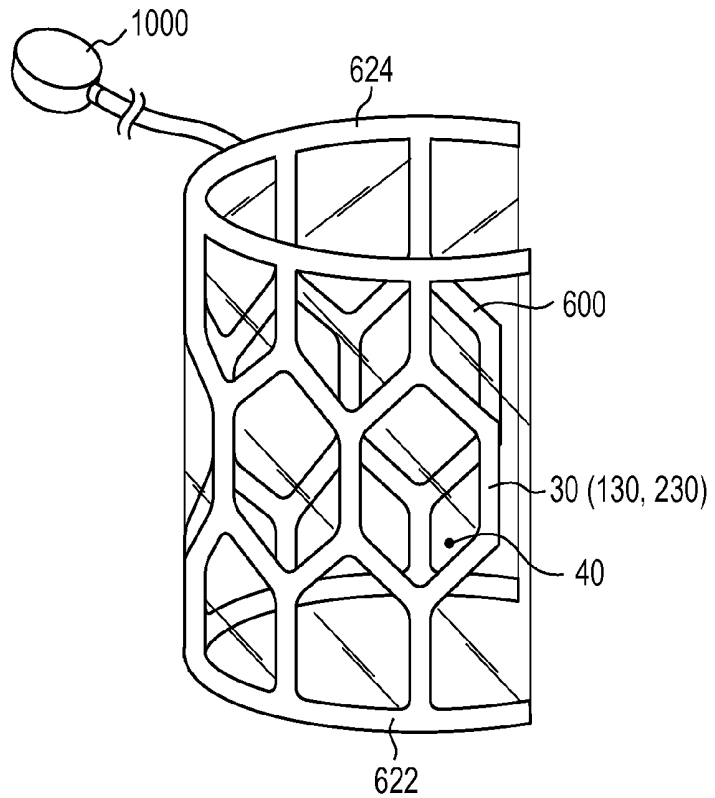

FIG. 6a

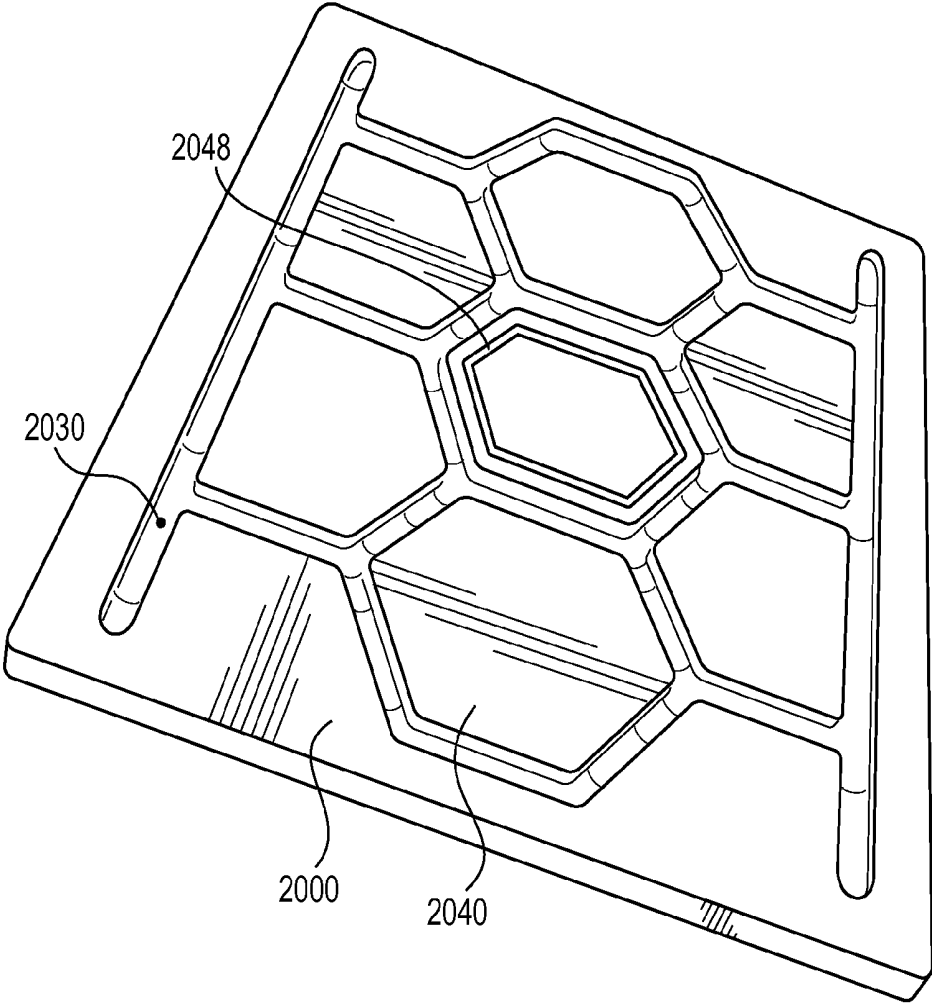

FIG. 7

## MEDICAL DEVICE WITH SELECTIVE RIGIDITY

### CROSS-REFERENCE TO RELATED APPLICATIONS

[0001] This application claims priority from U.S. provisional application No. 61/791,561, filed on Mar. 15, 2013, the entirety of which is hereby fully incorporated by reference herein.

### TECHNICAL FIELD

[0002] This disclosure relates to expandable and compressible structures for clinical use with respect to a patient.

### BRIEF SUMMARY

[0003] A first representative embodiment of the disclosure is provided. The embodiment includes a device for obtaining selective rigidity with respect to a patient is provided. The device includes a scaffold that is arranged to be flexible when in a first relaxed configuration, wherein the scaffold is configured to become substantially more rigid when a suction force is applied thereto. The scaffold comprises first and second opposing outer flexible layers that are sealed together to form a plurality of elongate pockets therein, and an expanded structure disposed within the plurality of elongate pockets and in communication with a vacuum port that receives the suction force.

[0004] Advantages of the present disclosure will become more apparent to those skilled in the art from the following description of the preferred embodiments of the disclosure that have been shown and described by way of illustration. As will be realized, the disclosed subject matter is capable of other and different embodiments, and its details are capable of modification in various respects. Accordingly, the drawings and description are to be regarded as illustrative in nature and not as restrictive.

### BRIEF DESCRIPTION OF THE DRAWINGS

[0005] FIG. 1 is a perspective view of a device for selective rigidity formed as a cylinder.

[0006] FIG. 2 is a perspective view of a device for selective rigidity formed as a sphere.

[0007] FIG. 3a is a view of a portion of an elongate pocket along section A-A of any one of FIG. 1, 2, or 6 in a normal configuration.

[0008] FIG. 3b is the view of FIG. 3a in the influence of a suction force.

[0009] FIG. 4a is a view of another type of elongate pocket along section A-A of any one of FIG. 1, 2, or 6 in a normal configuration.

[0010] FIG. 4b is the view of FIG. 4a in the influence of a suction force.

[0011] FIG. 5a is a view of another type of elongate pocket along section A-A of any one of FIG. 1, 2, or 6 in a normal configuration.

[0012] FIG. 5b is the view of FIG. 5a in the influence of a suction force.

[0013] FIG. 6 is a perspective view of a device for selective rigidity formed as a flat sheet.

[0014] FIG. 6a is the device of FIG. 6 formed into a c-shape.

[0015] FIG. 7 is a perspective view of a fixture for manufacturing a scaffold for use in a device for selective rigidity.

## DETAILED DESCRIPTION OF THE DRAWINGS AND THE PRESENTLY PREFERRED EMBODIMENTS

[0016] Turning now to FIGS. 1-7, a device 1 for obtaining selective rigidity with respect to a patient is provided. The device 1 may be used to assist with a medical procedure within an internal cavity of a patient (either a human, a mammal or other type of animal). Alternatively, the device 1 may be configured to be used to externally and in some embodiments temporarily with respect to a portion of a patient's anatomy.

[0017] In some embodiments, the device 1 may be formed into a tube or cylinder 10, as shown in FIG. 1. The cylinder 10 will be appreciated to be useful for various open surgical procedures, or various laparoscopic procedures. In some embodiments, the cylinder 10 may include opposed ends 22, 24, while in other embodiments, an extended end 24 (normally that extends further distally into the patient) may be closed, either with a window 40 (discussed below), or with a mesh or other suitable structure, while the opposite end 22 (e.g. an end closer to the vacuum line 28) is open. In other embodiments, both ends 22, 24 of the cylinder may be closed, such as in embodiments where the cylinder 10 is used to position tissue into a certain orientation or position, but where access within the cylinder 10 is not necessary.

[0018] By way of general example, in some clinical embodiments, the cylinder 10 may be configured to be used as an internal surgical retractor, or a flexible barrier that may be deployed within a surgical zone to isolate the surgical zone and neighboring tissue or viscera outside of the surgical zone. In other embodiments, the cylinder 10 may be configured to provide temporary or long term mechanical or radial support upon a structure or lumen, and act as a stent. In still other embodiments, the cylinder 10 may be configured to provide external mechanical support to a structure, or temporarily immobilize a structure, such as a cast or a splint.

[0019] In other embodiments as shown in FIG. 2, the device 1 may be formed into a sphere 400 or a similar construction. Embodiments where the device is shaped as a sphere 400 will be appreciated to be applicable or useful for the same or related clinical uses as listed above with respect to the cylinder 10, or other clinical uses where a cylinder is not clinically indicated. By way of clinical example, the sphere 400 may be used as a retractor used during laparoscopic or open surgery. Alternatively, by way of example, the device may be formed as a semi-circle (i.e. half of a hollow sphere) where the device forms a somewhat rigid support structure, such as a bicycle helmet.

[0020] In still other embodiments shown in FIGS. 6a and 6b, the device 1 may be formed into a sheet 600, which can clinically implemented as a sheet, or can be clinically implemented with the sheet configured into a three-dimensional shape, such as a C-shape depicted on FIG. 6b.

[0021] The device 1 is configured to be maintained in a flexible orientation when a plurality of elongate pockets 30 (130, 230) that define a scaffold 15 of the device 1 are in the normal expanded configuration, but the device 1 is configured to become substantially more rigid, and configured to significantly maintain a set geometry when the elongate pockets 30 (130, 230) are placed in communication with a source of suction, which withdraws a significant portion of the air (or other gasses) present within the internal volume 50 of the elongate pockets 30 (130, 230). The device 1 is configured to retain its normal flexibility when the suction is released from

the elongate pockets **30** (**130**, **230**), which allows the evacuated air to return to within the internal volume of the elongate pockets **30**.

[0022] In embodiments where the device is used as a retractor during laparoscopic surgery, the device **1** should be sufficiently compressible into a small cylindrical cross-section to fit through a typical laparoscopic port. This compressibility of the device **1** is based upon the overall compressibility of the foam (or another compressible material) used within the pockets **30** (**130**, **230**), discussed below, and the device **1** can expand on its own when within the patient. In some embodiments, the device **1** may be made to be expandable (particularly after being compressed to extend through a port) by “inflating” the plurality of pockets **30** (discussed below) using the vacuum port **28**. In embodiments where the device **1** used in laparoscopic surgery or even in open surgery the vacuum port **28** is configured to communicate outside of the patient to connect to a convenient source of suction **1000** (or positive pressure as discussed above).

[0023] Each of the cylinder **10**, the sphere **400**, or the sheet **600** may be made from the same or a related scaffold **15** design to form the same or similar elongate pockets **30** (**130**, **230**), which are depicted upon the respective cylinder **10**, sphere **400**, or sheet **600** through section A-A (FIGS. **1**, **2**, and **6a**, respectively). In some embodiments, the scaffold **15** may be formed like a honeycomb, with a plurality of elongate pockets **30** connected together that form structural walls and the spacing between neighboring elongate pockets **30** define a plurality of windows **40**. As shown in FIG. **1**, the scaffold **15** may be formed with multiple windows **40** arranged across the height of the scaffold **15**, between a first end **22** and a second end **24**, with the windows **40** staggered, or offset, between the upper and lower ends **22**, **24** of the scaffold **15**. As discussed herein, in some embodiments, each of the plurality of pockets **30** are fluidly connected together along the scaffold **15**, while in other embodiments the pockets **30** are fluidly connected in a groupwise manner.

[0024] In other embodiments, the windows **40** may be configured to be aligned along the height and circumference of the scaffold **15**, such as a scaffold **15** that defines a plurality of windows **40** that are shaped as stacked squares or rectangles. As will be understood by those skilled in the art with a thorough review of this application, scaffold **15** designs with staggered windows **40** (i.e. like a honeycomb) might be stronger in certain directions (or potentially in all directions) in parallel to the sheets **42**, **44** forming the scaffold **15**, and potentially in the directions radially into and/or out of the cylinder **10** and therefore better suited for some applications/shapes of the device **1**, while designs with stacked windows **40** may be of different/less strength than the staggered design and therefore better suited for use with other applications/shapes of the device **1**.

[0025] In other embodiments, for example, in some embodiments where the scaffold **15** forms a sphere (e.g. FIG. **2**) the scaffold **15** may be formed from a plurality of elongate pockets **30** (**130**, **230**) that form ribs that linearly extend from top **422** to the base **424** of the sphere (to define the curved surface of the sphere), which may form windows **40** that also extend from the top **422** to the base **424** of the sphere. In other embodiments, the scaffold **15** may further include a plurality of horizontal ribs (**30z**, one potential horizontal rib shown in broken lines on FIG. **2**) to provide additional structural support to the scaffold **15** and to decrease the size of the windows **40**.

[0026] In some embodiments, the device **1**, such as the cylinder **10** or the sphere **400**, as shown in FIG. **2**, may receive a cap **500** that removably closes a portion or all of the open top **422** of the device **1**. By way of example, the cap **500** may be used in situations where the device **1** is used as a retractor for open surgery, but it is desired to insufflate the abdomen during open surgery or to limit the overall exposure of the surgical field to the atmosphere. In this instance, the cap **500** may include one or more ports **510** that act as laparoscopic ports. In situations where the device **1** is configured to receive a cap **500**, the device **1** (such as the spherical embodiment **400** shown in FIG. **2**), may include a support **480** (either made from the plurality of pockets **30**, or from other structure attached to the device) that supports the cap **500**, and may extend outside of the patient during use.

[0027] The scaffold **15** may be constructed such that all of the elongate pockets **30** (**130**, **230**) that define the structural walls of the scaffold **15** are fluidly connected, such that a suction (or vacuum force) that is applied to a portion of the scaffold **15** communicates throughout the entire scaffold **15**. In other embodiments, the scaffold **15** may be formed from two or more independent fluid zones, wherein each elongate pocket **30** within a single zone is fluidly connected, but multiple zones within a single scaffold **15** are not directly fluidly connected. In embodiments with multiple fluid zones, each fluid zone may be connected to the same vacuum source (shown schematically as **1000**) through a common vacuum port **28**, or through separate vacuum ports **28** that connect to the vacuum source through a common header (or different vacuum sources **1000**). As will be appreciated, embodiments with scaffolds **15** that define multiple fluid zones may be useful for the sake of redundancy, such that a loss of suction (either due to a leak or blockage along a portion of an elongate pocket **30**) in one fluid zone (which, as discussed below may cause the scaffold **15** in that zone to lose all or a portion of its rigidity) will not lose suction (rigidity) in the remaining zones.

[0028] In some embodiments, the scaffold **15** may be constructed from two thin parallel sheets **42**, **44** of flexible material that are aligned in over or next to each other. The two sheets of material **42**, **44** (such as polyethylene (Mylar), Nylon, or PVA, or other suitable materials) are bonded or heat sealed together along various edges **48a** to define windows **40**, and to define elongate pockets **30** (**130**, **230**), which are defined between two parallel seams **48a**. The thin sheets **42**, **44** may each be about 0.005 to about 0.002 inches thick (inclusive of all thicknesses within this range), or may be a thicker material that is still sufficiently flexible to allow a vacuum to be drawn within the elongate pockets **30**, and to accept the desired shape of the device **1**. In some embodiments, the first and second sheets **42**, **44** may be sealed together throughout the entire area of each window **40**, while in other embodiments, the first and second sheets **42**, **44** are only sealed together to define each seam **48a**. Finally, in some embodiments sheets **42**, **44** forming the windows **40** within the scaffold **15** may be cut (without cutting the seams **48a**) to allow for access through the device, such as through a retractor, to access a portion of the viscera outside of the retractor.

[0029] In some embodiments, the seams **48a** are constructed to be substantially air-tight. In some embodiments, an elongate wire or cord **48** may be disposed between the two sheets of material **42**, **44** where the seam **48a** is to be formed. When provided, the wire or cord **48** provides a surface upon which both opposite sheets of material **42**, **44** are sealed to

prevent any discontinuities in the sealed edge **48a** (that could leak air therethrough) or to block air flow in situations where small discontinuities in the seal **48** exist. In other embodiments, the two sheets **42**, **44** may be sealed directly together along the sealed edge **48a**.

**[0030]** The pockets **30** (**130**, **230**) may include a volume of foam or other expanded and compressible material that is disposed upon the length of the elongate pocket **30**. The compressible material may be a foam, such as an open cell foam formed with a plurality of voids (schematically as **56** in FIG. **3a**) distributed throughout the volume of the foam. Some suitable materials may be expanded polyethylene, or foams made of other expanded materials. In some embodiments polyester foams may be suitable, such as known “acoustic” foam. In other embodiments, the compressible material may be a plurality of small particles, granules, pellets, ground-material such as bio-compatible expanded foam pellets, coarse-ground coffee, poly vinyl alcohol (PVA) granules, or polymeric regular polyhedrons peanuts, or similar regular or irregular shaped rigid pieces, which will jam against one another when compressed by an overlying film and resist sliding past one another and are relatively light in weight for their given volume.

**[0031]** A first configuration for an elongate pocket **30** is depicted in FIGS. **3a** and **3b**. The pocket **30** is defined by two elongate seams along parallel edges **48a**, which are formed by bonding or sealing the two sheets of material **42**, **44** therealong. The pocket **30** includes an internal volume, which receives one or more cylindrical strips of foam **52** or other type of expanded and collapsible structure (such as foam **52** or other materials) that extends along the length of the pocket **30**. The foam **52** may be round in cross-section, or in other embodiments oval, elliptical, arcuate, square, or other thin polygonal shapes in cross-section. As shown schematically in FIG. **3a**, the foam **52** includes a plurality of voids **56**, normally filled with air when the foam **52** is in its normal expanded state, and due to the circular cross-section of the foam **52** with respect to the pocket **30**, the pocket includes empty portions **50** between each seal **48a** and each opposite radial side of the foam **52**.

**[0032]** As shown in FIG. **3a**, the pocket **30** (and therefore the scaffold **15** as a whole) is substantially flexible when in the normal configuration, due to the normal flexibility of the foam **52** and the air within the empty portions **50** of the pocket **30**. As shown in FIG. **3b**, when a suction is drawn within the pocket **30**, the plurality of voids **56** in the foam **52** are compressed (as shown schematically as **56a**) due to the air being withdrawn from within the foam **52**, as well as the air withdrawn from the open spaces within the pocket **30**. As a result of the air being withdrawn, the walls of the pocket **30** are pushed toward the compressed foam **52** (due to the relatively larger air pressure outside of the pocket **30** than within the pocket **30**), and the compressed foam **52** becomes significantly more rigid (due to the collapse of the air gaps **56**, which normally are compressed and expanded with the application of only minimal force to the foam **56**), which causes the scaffold **15** to also become more rigid. As shown schematically as element **30b**, the sheets **42**, **44** defining the pocket **30** are pulled together, further increasing the rigidity and potentially changing the cross-section of the foam **52**.

**[0033]** Turning now to FIGS. **4a** and **4b**, another configuration for an elongate pocket **130** is depicted. The pocket **130** that is suitable for construction of a scaffold **15** is schematically depicted, in the normal flexible state (FIG. **4a**) and in the

rigid state (FIG. **4b**) due to the application of a suction to the pocket **130**. The pocket **130** may be defined between two parallel seams **48a** that may be formed as described elsewhere herein. The pocket **130** is full with a plurality of loosely packed pellets **150** peanuts, balls, or other types of small discrete structures of foam or another compressible and flexible material. When resting within the pocket **130** a plurality of spaces are present between neighboring pellets **150**, which allows the pocket **130** to be flexible due to the ease of realignment of the plurality of pellets **150** within the pocket **130**.

**[0034]** As shown in FIG. **4b**, when a suction is drawn within the pocket **130**, the volume of the pocket **130** is compressed due to the higher relative pressure outside of the pocket **130** than within the pocket **130**. Further, in embodiments where the pellets **150** are formed from foam, any voids (not shown, but similar to voids **56** within the foam **52**, discussed above) within the foam pellets **150** are compressed due to the air being evacuated from within the pellets **150**. The compression of the pellets **150** urges contraction, and to more tightly fit together, as further urged together by the reduction of air within the pocket **130**. The combination of the increase in rigidity of individual pellets **150** and the overall tighter pack of neighboring pellets **150** (schematically in FIG. **4b** as **156a**) causes the rigidity within the pocket **130** to increase (which causes the rigidity of the scaffold **15** to increase). As depicted as element **130a**, the sheets **42**, **44** defining the pocket **130** may be pulled together as shown with element **130b**, further increasing the rigidity of the pocket **130**.

**[0035]** Turning now to FIGS. **5a** and **5b**, another elongate pocket **230** is depicted. The pocket **230** that is suitable for construction of a scaffold **15** is schematically depicted, in the normal flexible state (FIG. **5a**) and in the rigid state (FIG. **5b**) due to the application of a suction to the pocket **230**. As with the other pockets discussed above, the pocket **230** may be defined between two parallel seams **48a** that may be formed as described elsewhere herein. The pocket **230** receives one or more elongate strips of foam **250** with a rectangular cross-section along its length. As with the foam **52** discussed above, the foam **250** may include a plurality of voids **256** that are normally filled with air, that allow the expanded foam **250** to be easily expanded. In some embodiments, the foam **250** with the rectangular cross-section may be preferred to provide for increased strength in one direction and decreased strength in the perpendicular direction. For example, in the embodiment shown in FIG. **5a**, the wider faces **254** are in parallel with the sheets **42**, **44** that define the pocket **230** (and the windows), while the narrower faces **255** are perpendicular to the sheets **42**, **44**. As can be understood, the pockets **230** in this configuration will be more resistant to bending in a direction parallel with the sheets **42**, **44** than a direction perpendicular to the sheets **42**, **44** (i.e. into and out of the page displaying FIG. **5a**) due to the larger thickness of the foam **250** in the direction parallel with the sheets **42**, **44**. Placement of the foam **250** in a perpendicular alignment would make the scaffold **15** more resistant to bending into or out of the page upon which FIG. **5a** is printed.

**[0036]** As shown in FIG. **5b**, when a suction is drawn within the pocket **230**, the volume within the pocket **230** is compressed due to the higher relative pressure outside the pocket **230** than within the pocket **230**. Further, the suction additionally causes the voids **256** within the foam **250** to collapse (as discussed above with respect to voids **56**), which compresses the foam **250** and makes the foam **250** more rigid, which ultimately makes the pocket **230** and the scaffold **15** more

rigid. Moreover, as shown schematically in FIG. 5*b*, the collapsing of the voids 256 may cause the foam 250 to establish a non-uniform cross-section, with somewhat arcuate faces, and may cause the width W of the compressed foam (FIG. 5*b*) to be less than the width X of the expanded foam (FIG. 5*a*). As shown with element 230*b*, the sheets 42, 44 forming the opposite walls of the pocket 230 are pulled together as the air is evacuated out of the pocket 230, further increasing the rigidity of pocket 230.

[0037] In some embodiments, the plurality of pockets 30 (130, 230) forming the scaffold 15 may be formed from different constructions within the same scaffold 15, such as portions formed with pockets 30 with portions also formed with pockets 130 and/or pockets 230. As will be appreciated, the use of different pockets with different flexibilities will render a scaffold 15 with specific relatively more or less strong or flexible portions as may be warranted for different design applications. In other embodiments, pockets may be formed with different structures within each pocket, such as, by way of example, the rectangular form 250 and a plurality of pellets 150 disposed outboard of the rectangular foam 250.

[0038] FIG. 7 depicts a fixture 2000 for forming a scaffold 15. The fixture 2000 may be a flat board that includes a network of tunnels 2030 that are configured in the arrangement where the elongate pockets 30 (130, 230) are desired. The outer-most surface of the fixture 2000 may include planar sections 2040 that are disposed where the windows 40 are desired. In some embodiments, the planar sections 2040 of the fixture 2000 may be heated to assist with the formation of the seams 48*a*, and/or to melt the opposite sheets 42, 44 forming the outer surface of the scaffold 15 together. In some embodiments, the fixture 2000 may include secondary tunnels 2048 that closely surround the tunnels 2030 to provide for placement of the wire or cord 48 to assist in defining the seams 48. As can easily be appreciated, to construct a scaffold, a first sheet 42 may be disposed upon the fixture 2000 and then the material (foam 52, pellets, foam 250, or a combination of these) is placed within the tunnels 2030 on top of the first sheet 42. A second sheet 44 is then placed on the fixture 2000 on the first sheet 42. The seams 48*a* may then be formed by an external tool, or in other embodiments, a second fixture 2000 contacts the second sheet 44 compressively and may form the seal 48*a* upon the application of heat. Upon formation of the scaffold 15, the scaffold 15 may then be fixed into the desired shape or orientation, and the vacuum line 28 attached to the pocket 30 to provide communication of suction from the vacuum line 28 to the pockets 30.

[0039] While the preferred embodiments of the disclosed have been described, it should be understood that the invention is not so limited and modifications may be made without departing from the disclosure. The scope of the disclosure is defined by the appended claims, and all devices that come within the meaning of the claims, either literally or by equivalence, are intended to be embraced therein.

1. A device for obtaining selective rigidity with respect to a patient, comprising:

a scaffold that is arranged to be flexible when in a first relaxed configuration, wherein the scaffold is configured to become substantially more rigid when a suction force is applied thereto, the scaffold comprising first and second opposing outer flexible layers that are sealed together to form a plurality of elongate pockets therein, and an expanded structure disposed within the plurality

of elongate pockets and in communication with a vacuum port that receives the suction force.

2. The device of claim 1, wherein the expanded structure is configured to compress upon itself when in the presence of the suction force.

3. The device of claim 2, wherein the expanded structure compresses upon itself due to a substantial collapsing of a plurality of voids associated with the expanded structure.

4. The device of claim 1, wherein two or more pockets defining the plurality of elongate pockets are each in communication with each other and also in communication with the vacuum port such that the suction force communicates throughout the two or more pockets defining the plurality of pockets.

5. The device of claim 1, wherein the scaffold is disposed in a generally cylindrical configuration when fully expanded.

6. The device of claim 1, wherein the scaffold comprises a first closed end and a second open end, wherein the port is proximate to the second open end.

7. The device of claim 1, wherein the scaffold is disposed in a generally spherical configuration when fully expanded.

8. The device of claim 1, wherein the plurality of elongate pockets are oriented to define a plurality of windows formed from one or both of the first and second flexible layers disposed between the two or more of the plurality of elongate pockets.

9. The device of claim 8, wherein each of the plurality of windows are defined with the first and second layers sealed together.

10. The device of claim 8, wherein the plurality of windows are substantially transparent.

11. The device of claim 1, wherein the plurality of elongate pockets are aligned with respect each other to form a honeycomb structure along outer walls of the scaffold.

12. The device of claim 1, wherein the elongate pockets comprise a foam structure disposed therein.

13. The device of claim 12, wherein the foam structure is configured to substantially collapse upon itself when in communication with a suction force.

14. The device of claim 12, wherein the foam structure is defined from elongate strips of foam disposed within the plurality of pockets.

15. The device of claim 10, wherein the foam structure is defined from a plurality of foam pellets distributed within the plurality of pockets.

16. The device of claim 1, wherein the scaffold defines a retractor.

17. The device of claim 16, wherein the retractor is configured for use within the peritoneal cavity.

18. The device of claim 16, wherein the scaffold is defined to be deployable into a working area of a patient through a laparoscopic port, wherein the vacuum port extends out of the laparoscopic port.

19. The device of claim 1, wherein the scaffold defines a stent.

20. The device of claim 8, wherein one or more of the plurality of windows may be removed from the scaffold when the scaffold is in the relaxed configuration or the suction configuration.

21. The device of claim 1, wherein the scaffold is configured to rigidly support a portion of the anatomy.

\* \* \* \* \*

专利名称(译)	选择性刚性的医疗设备		
公开(公告)号	<a href="#">US20140277384A1</a>	公开(公告)日	2014-09-18
申请号	US14/203007	申请日	2014-03-10
[标]申请(专利权)人(译)	库克医学技术有限责任公司		
申请(专利权)人(译)	库克医疗技术有限责任公司		
当前申请(专利权)人(译)	库克医疗技术有限责任公司		
[标]发明人	MELSHEIMER JEFFREY S		
发明人	MELSHEIMER, JEFFREY S.		
IPC分类号	A61B17/02 A61F2/82		
CPC分类号	A61B17/0218 A61B2017/0225 A61F2/82 A61M25/0054 A61F2/90 A61F2250/0003 A61F2250/0018 A61M25/1025		
优先权	61/791561 2013-03-15 US		
其他公开文献	US9445801		
外部链接	<a href="#">Espacenet</a> <a href="#">USPTO</a>		

摘要(译)

提供了一种用于获得对患者的选择性刚性的装置。该装置包括支架，该支架设置成在处于第一松弛构型时是柔性的，其中支架构造当向其施加抽吸力时变得基本上更加刚性。支架包括第一和第二相对的外柔性层，其被密封在一起以在其中形成多个细长袋，以及扩展结构，其设置在多个细长袋内并与接收抽吸力的真空端口连通。

