



US 20140263570A1

(19) **United States**

(12) **Patent Application Publication**  
**Hopkins et al.**

(10) **Pub. No.: US 2014/0263570 A1**

(43) **Pub. Date: Sep. 18, 2014**

(54) **SURGICAL STAPLER WITH PARTIAL  
POCKETS**

**Publication Classification**

(71) Applicant: **Applied Medical Resources Corporation**, Rancho Santa Margarita, CA (US)

(51) **Int. Cl.**  
*A61B 17/072* (2006.01)

(72) Inventors: **Timothy Hopkins**, Rancho Santa Margarita, CA (US); **Donald L. Gadberry**, Rancho Santa Margarita, CA (US); **Matthew M. Becerra**, Rancho Santa Margarita, CA (US); **Babak Jasebian**, Rancho Santa Margarita, CA (US); **Gary M. Johnson**, Rancho Santa Margarita, CA (US); **Steven E. Decker**, Rancho Santa Margarita, CA (US)

(52) **U.S. Cl.**  
CPC ..... *A61B 17/07207* (2013.01)  
USPC ..... **227/180.1; 227/176.1**

(73) Assignee: **Applied Medical Resources Corporation**, Rancho Santa Margarita, CA (US)

(57) **ABSTRACT**

A surgical stapler includes a jaw assembly at a distal end connected to a handle assembly that is configured to control the stapler and actuate the deployment of staples. The surgical stapler successfully eliminates intermediate camming portions commonly known as pushers that are located between the staples and a translating slider. The staples are located in pockets at an angle such that the base of the staple is parallel to an angled camming surface of the slider. The translating slider comes into direct contact with staples during deployment as the slider moves through each staple pocket where staples are partially supported by recesses along the slider pathway. The staples are deployed at an angle against the anvil surface. Because there are no pushers, a great deal of space is saved resulting in a much smaller diameter surgical stapler that is particularly suitable for laparoscopic stapling applications.

(21) Appl. No.: **14/212,357**

(22) Filed: **Mar. 14, 2014**

**Related U.S. Application Data**

(60) Provisional application No. 61/785,100, filed on Mar. 14, 2013.

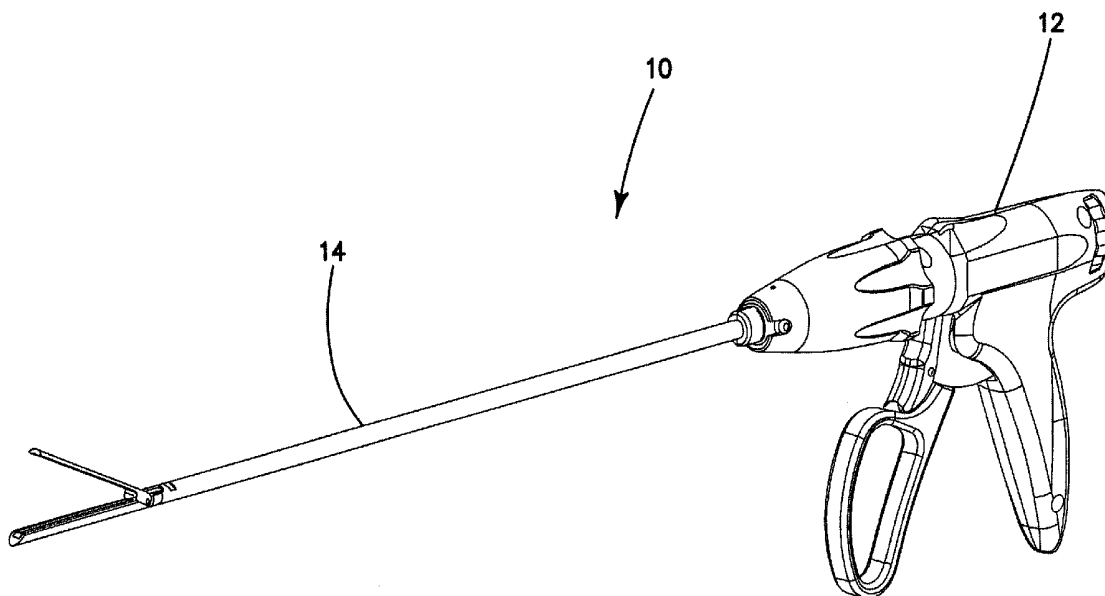

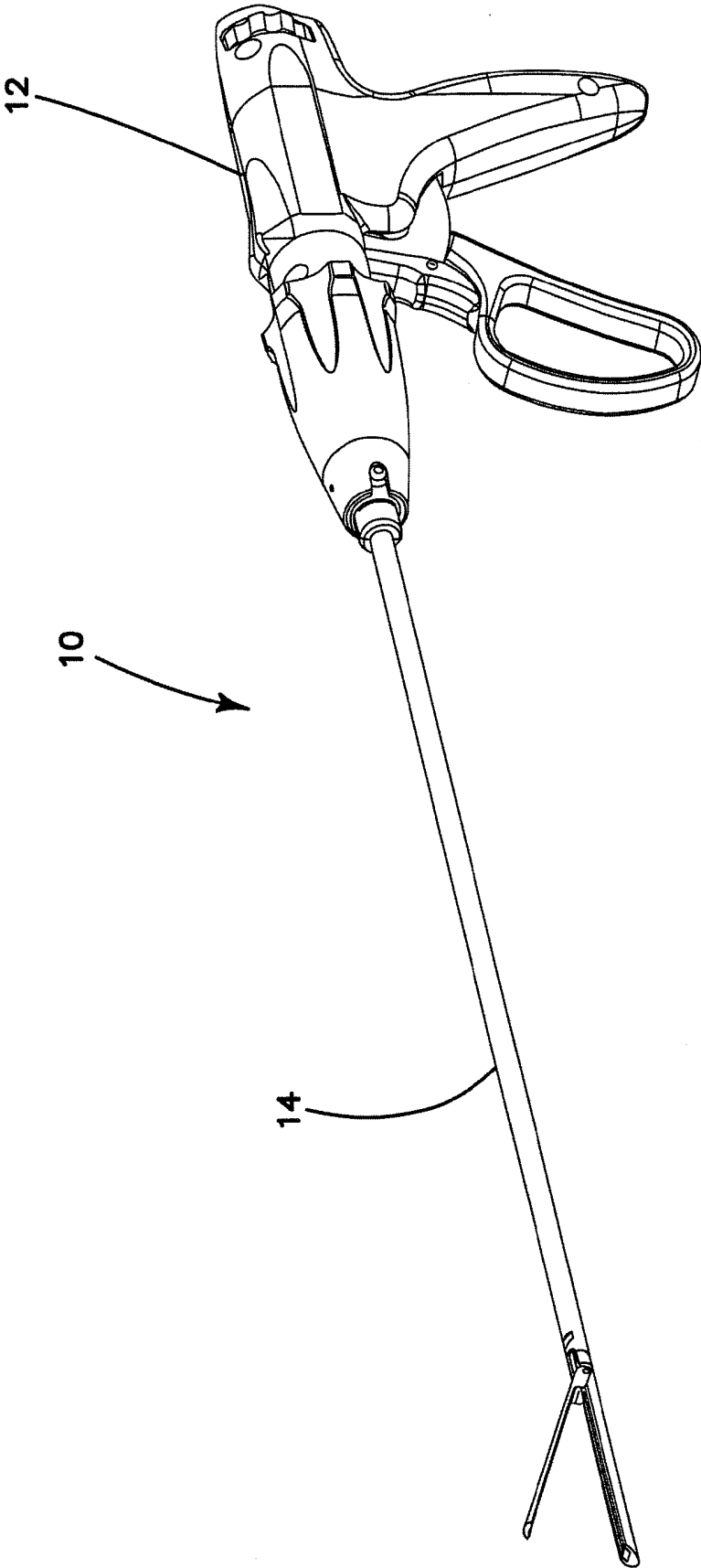
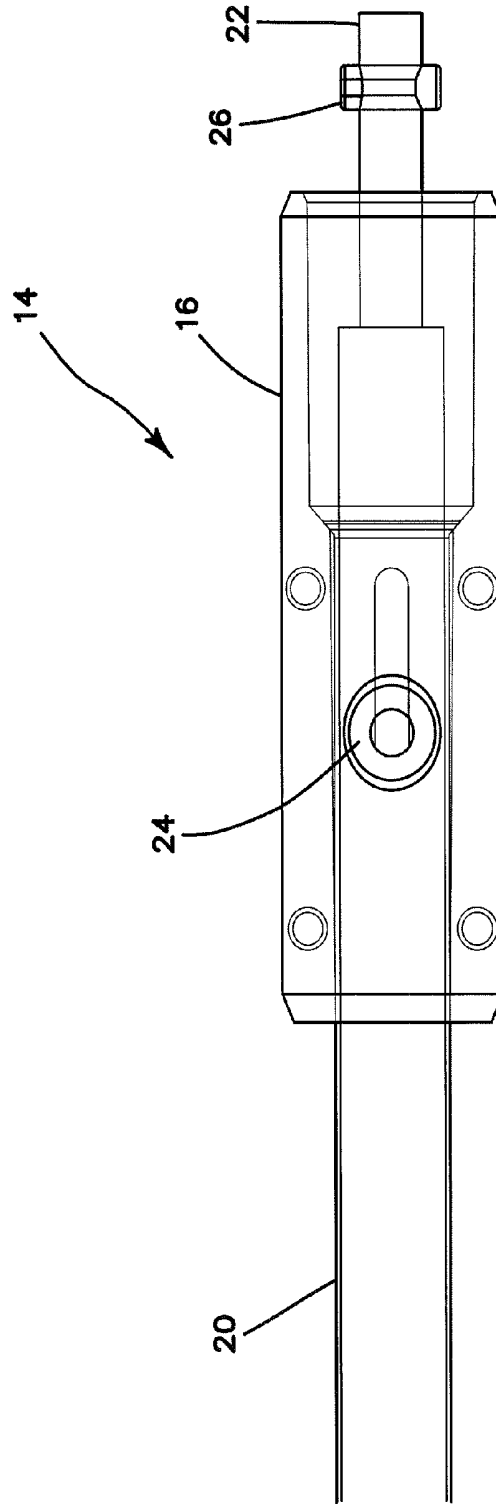
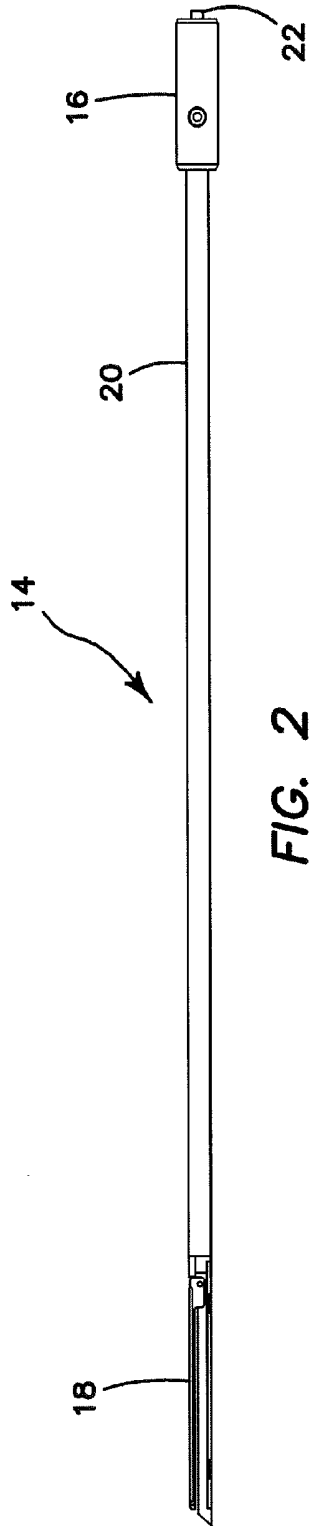

FIG. 1



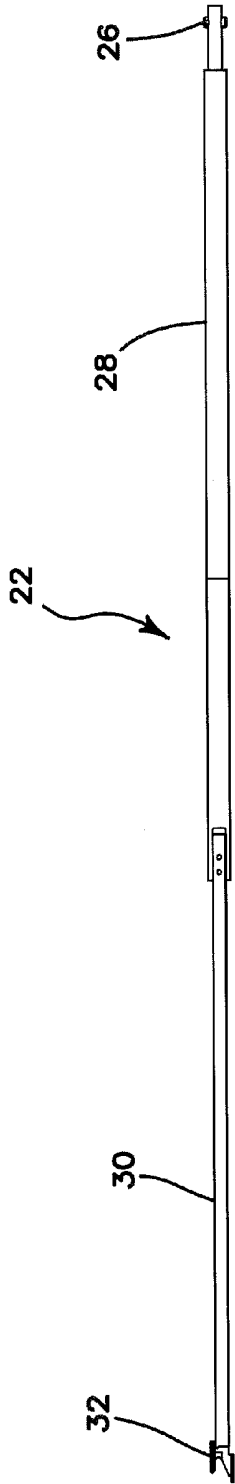

FIG. 4

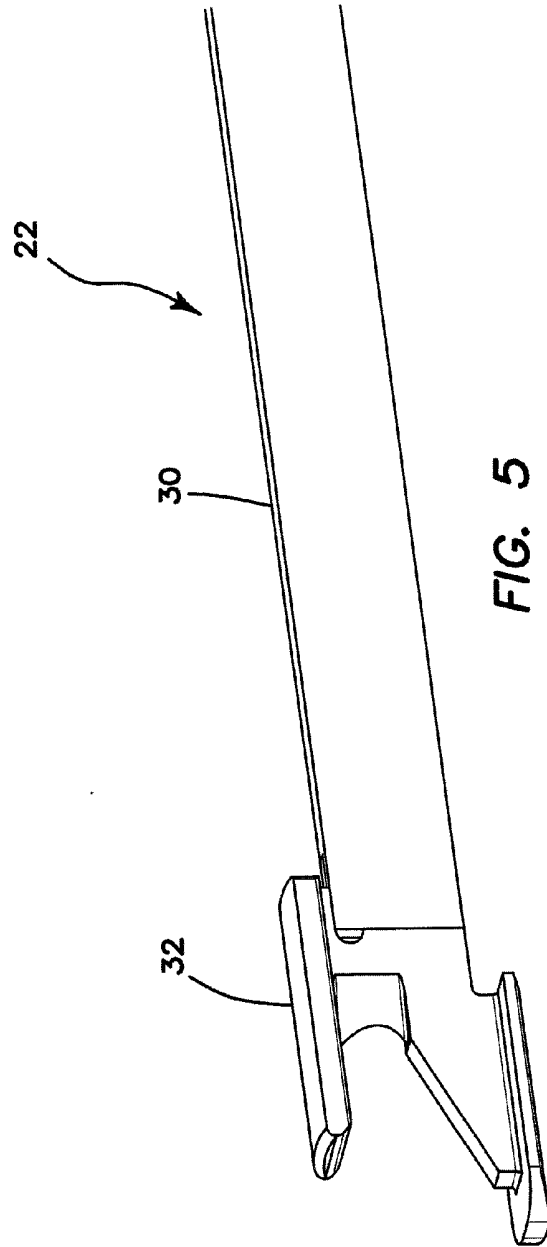
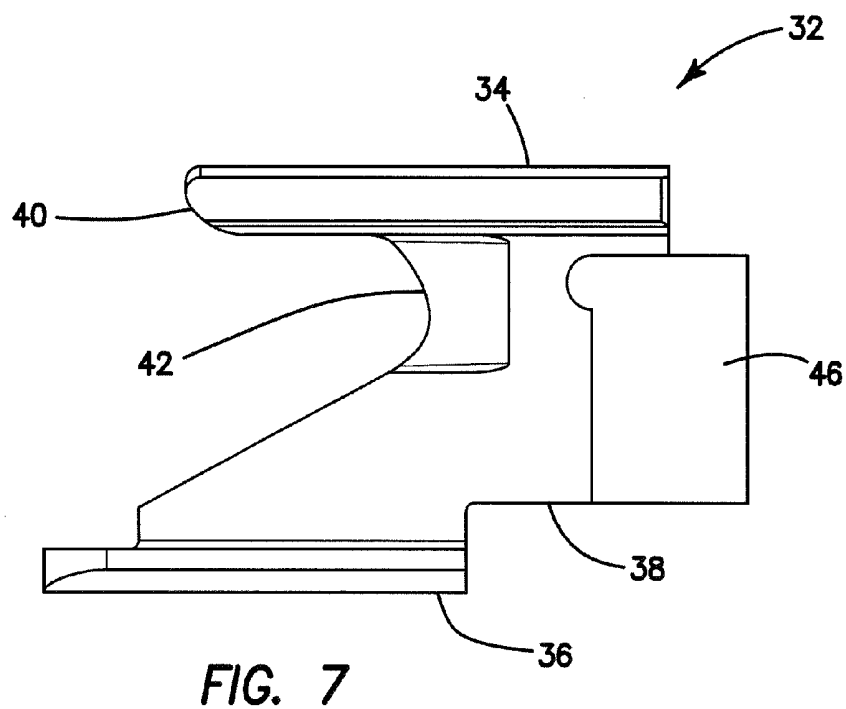
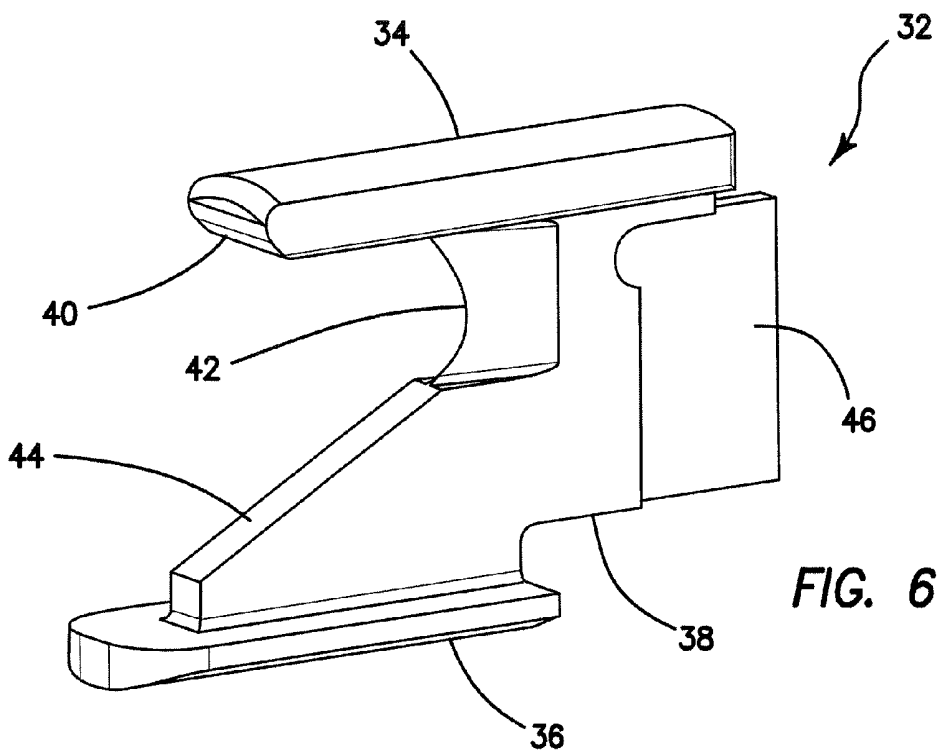

FIG. 5



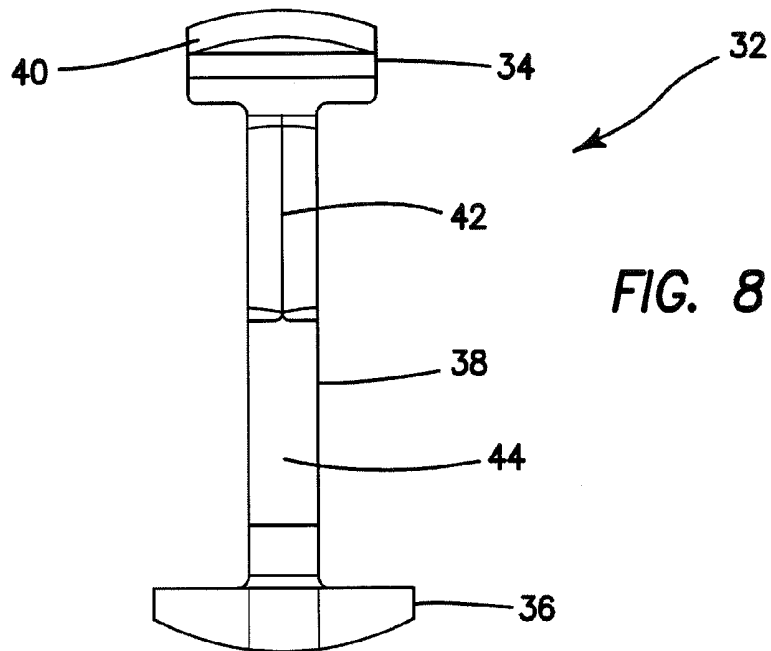

FIG. 8

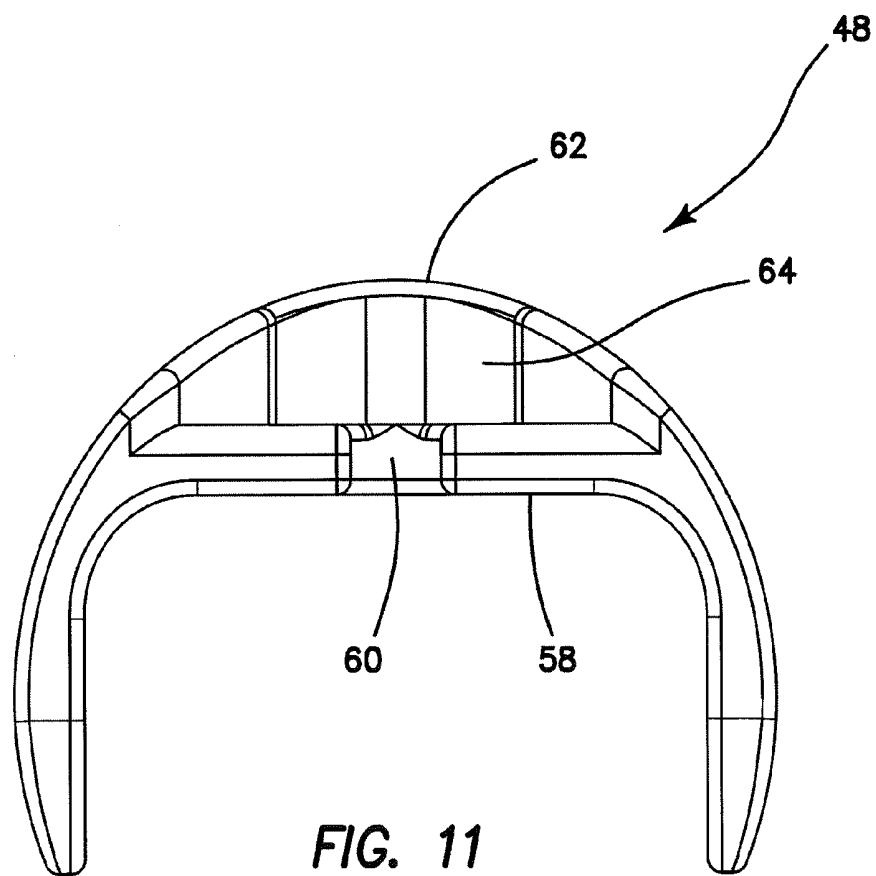

FIG. 11

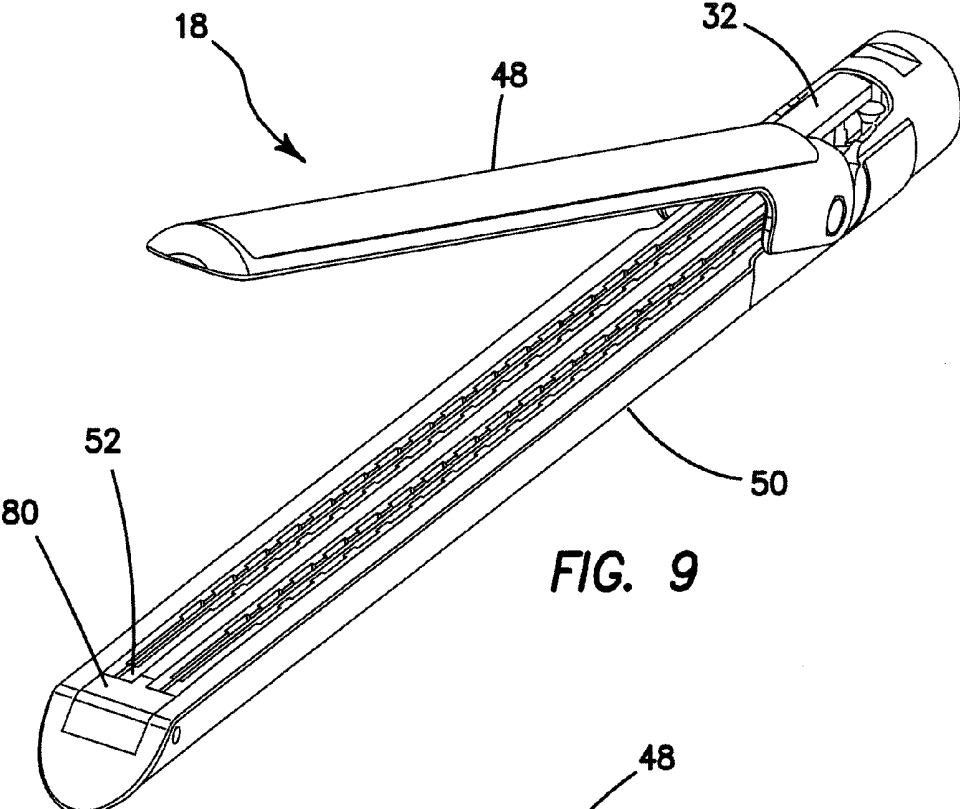

FIG. 9

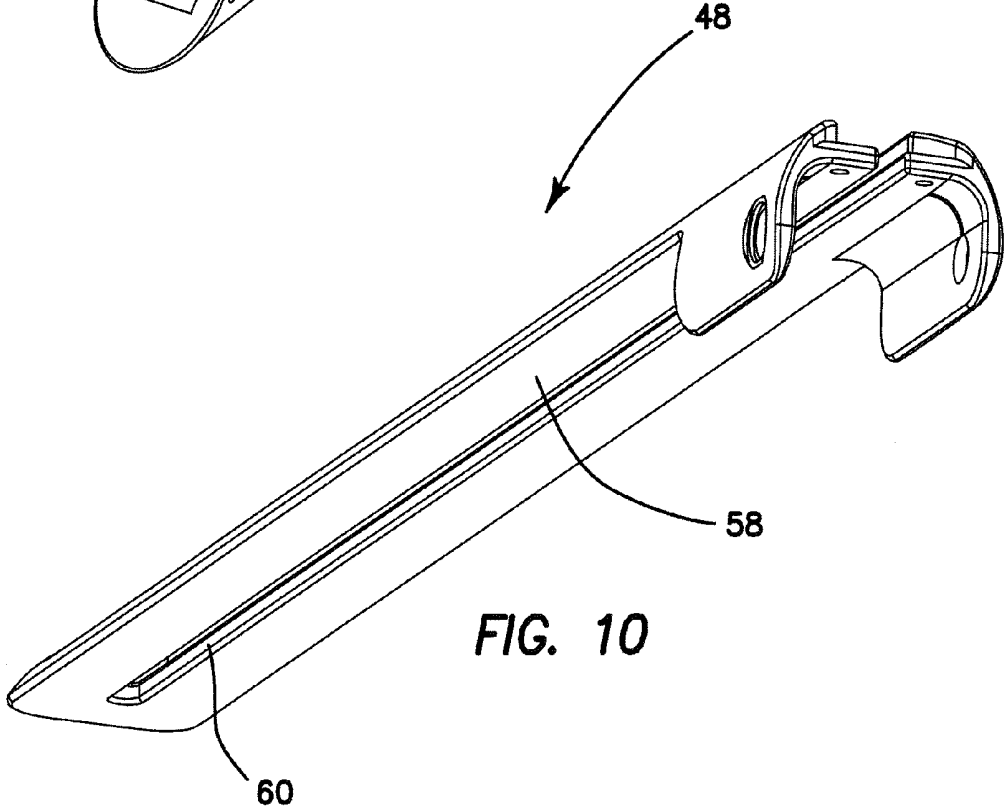
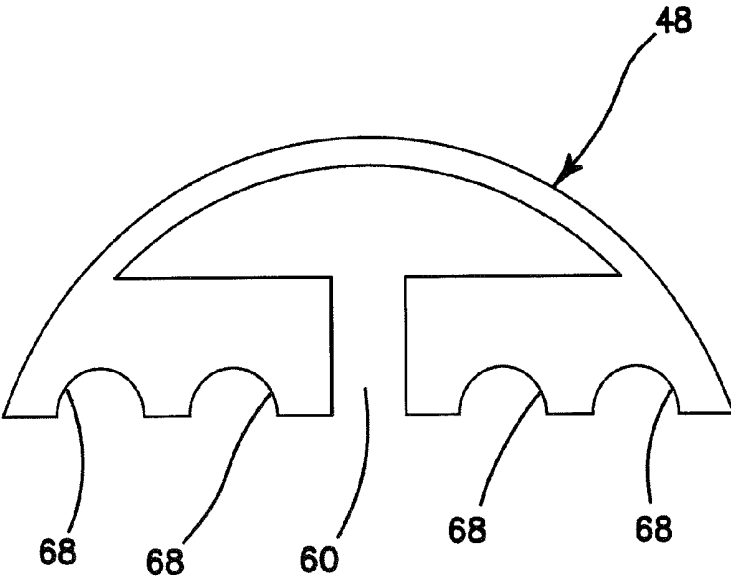
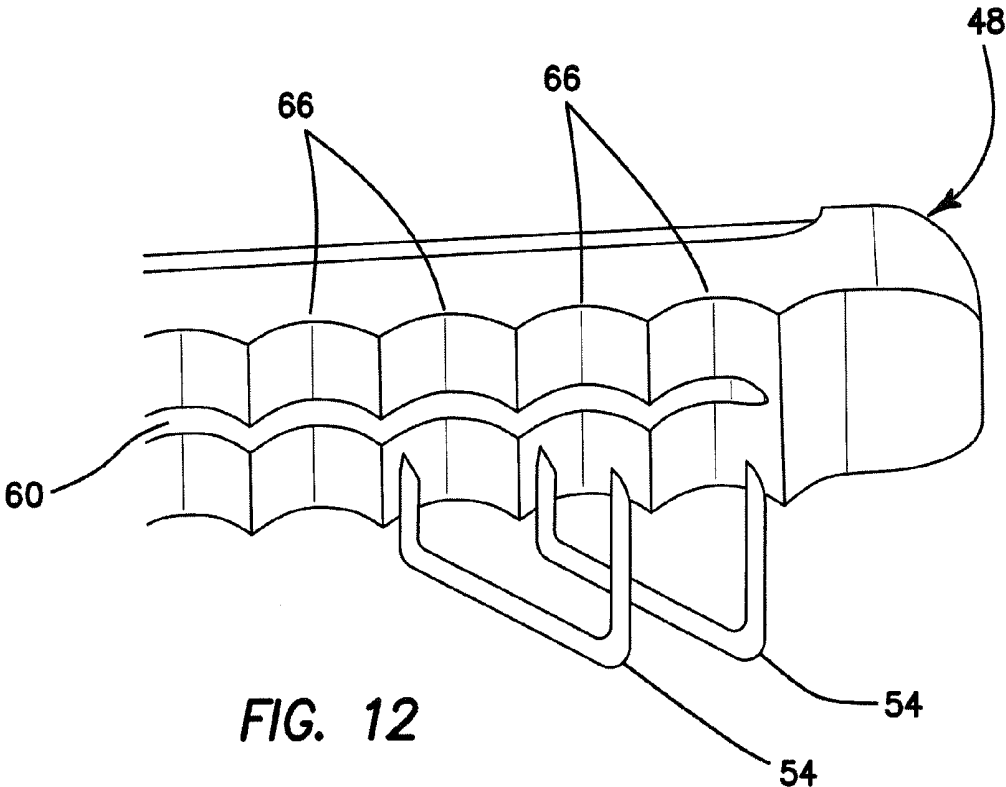
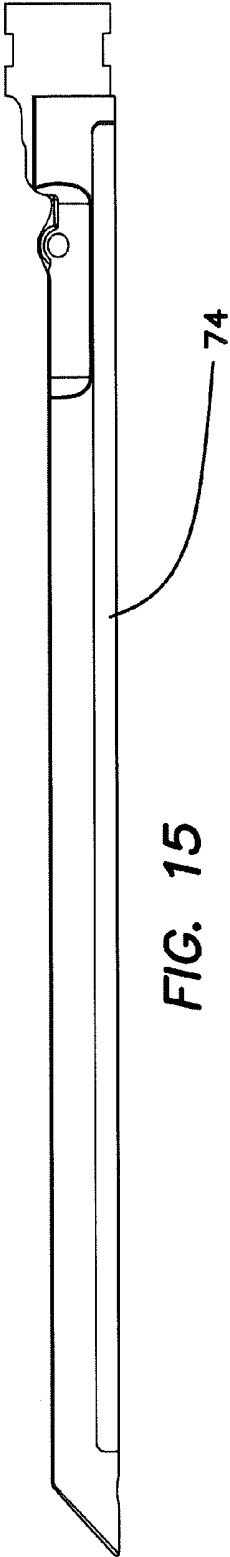
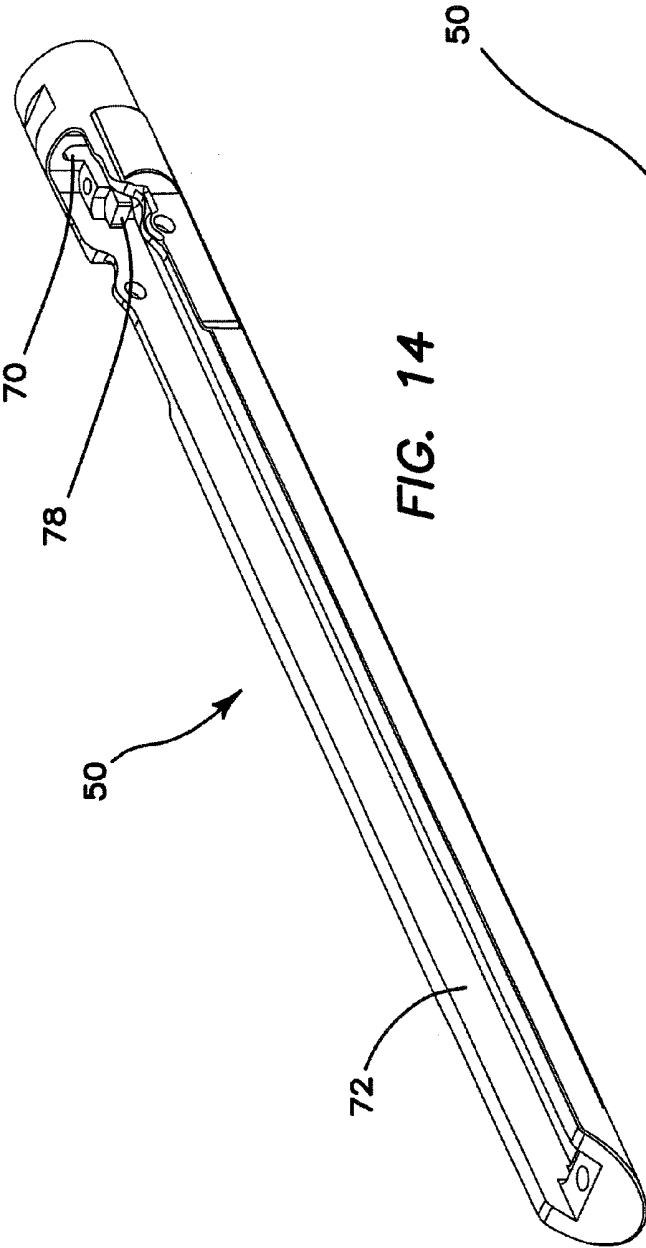

FIG. 10





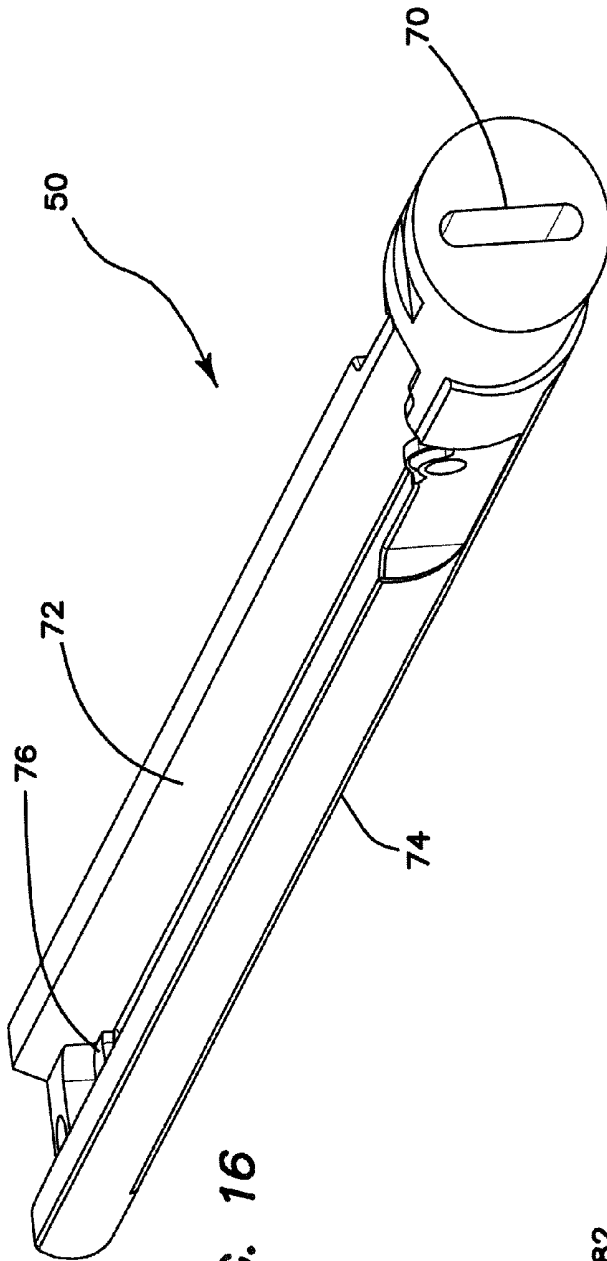

FIG. 16

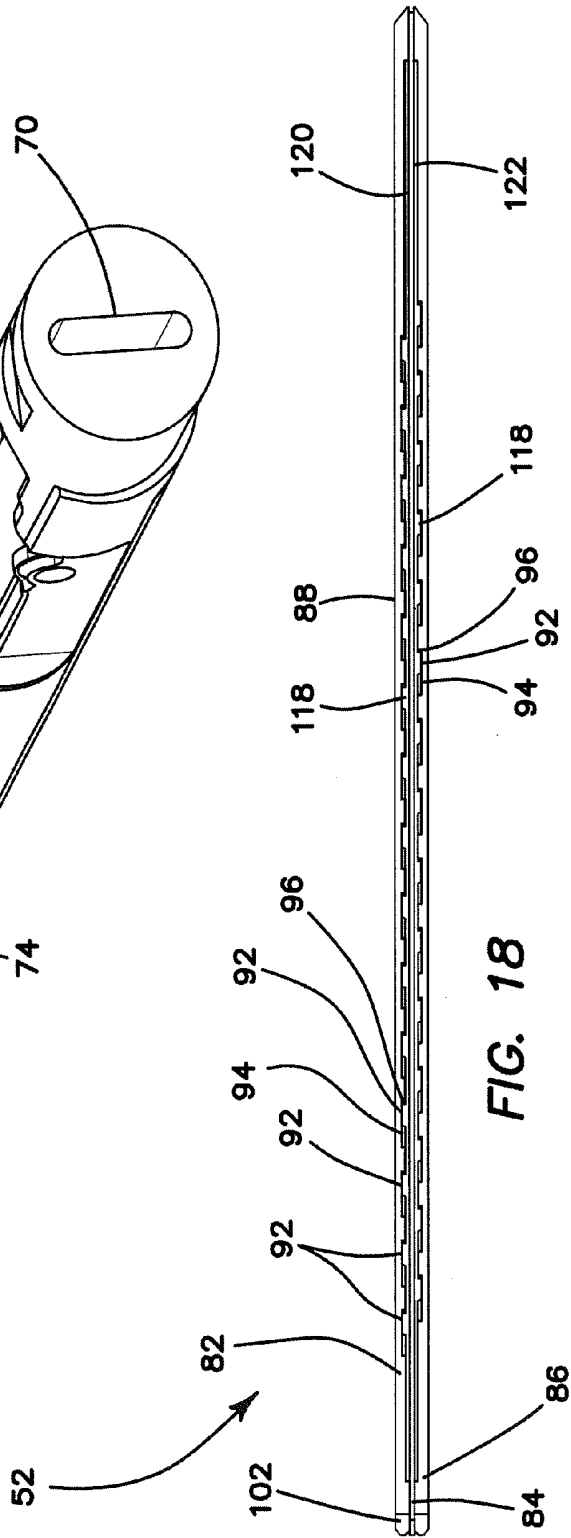
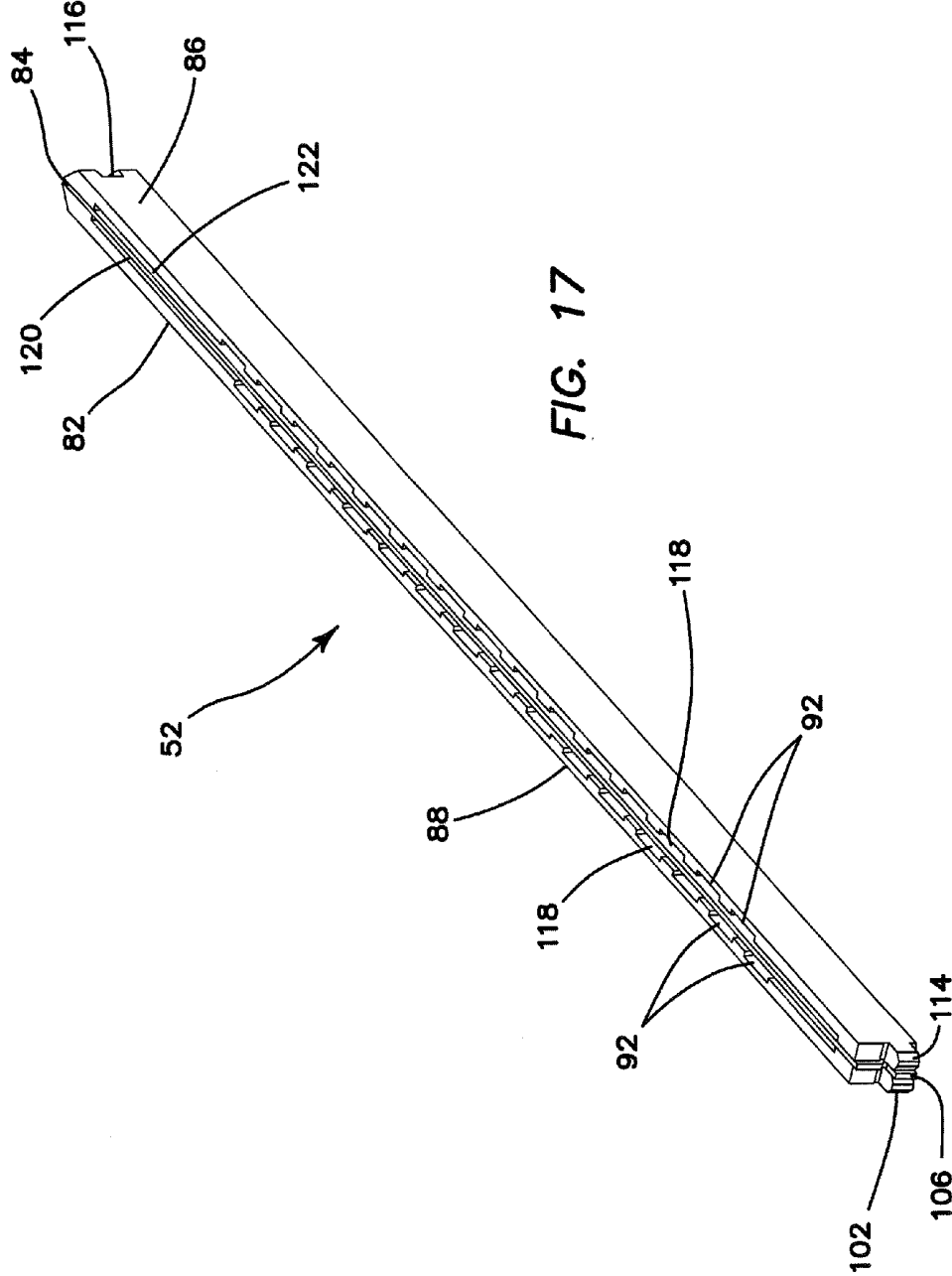

FIG. 18





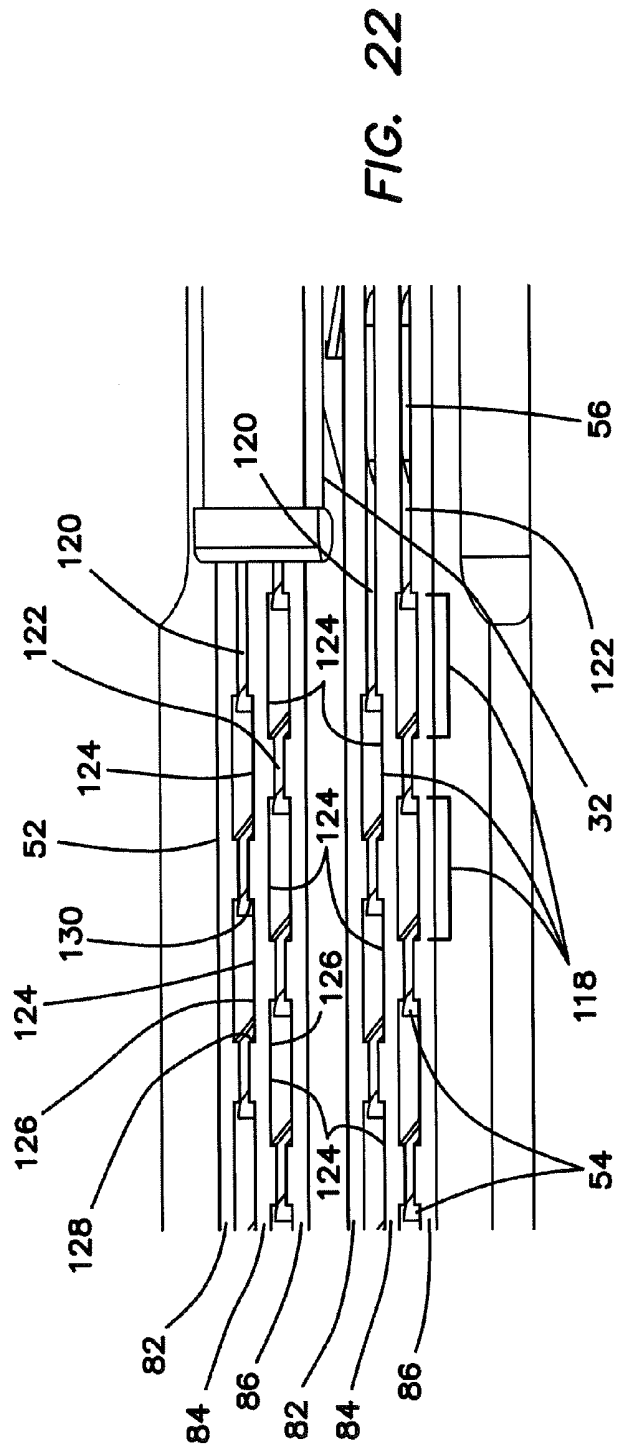
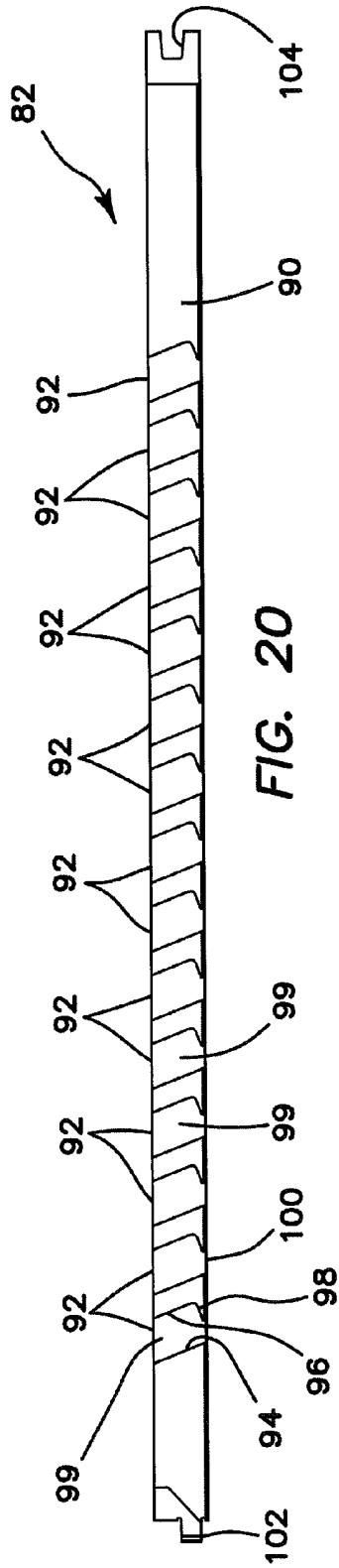



FIG. 23

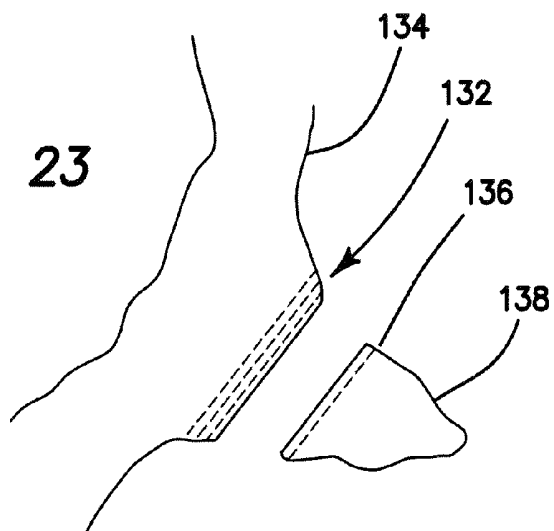

FIG. 24

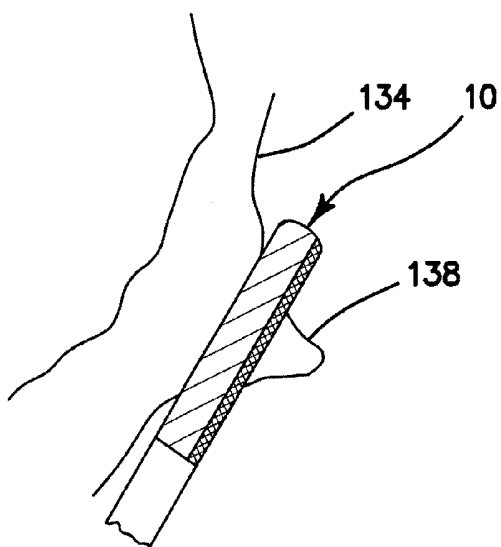
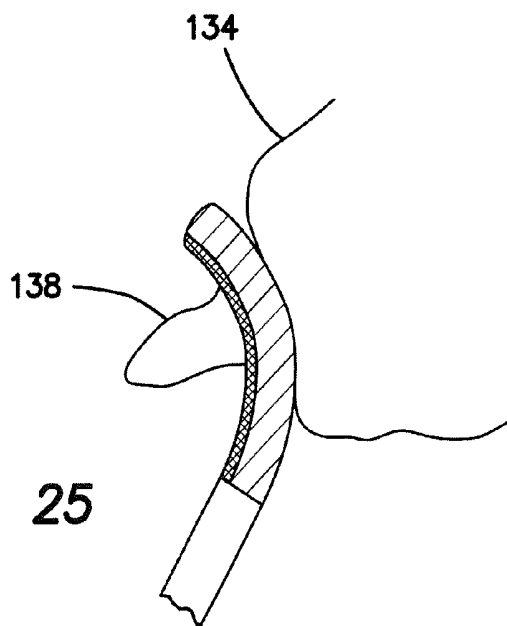

FIG. 25



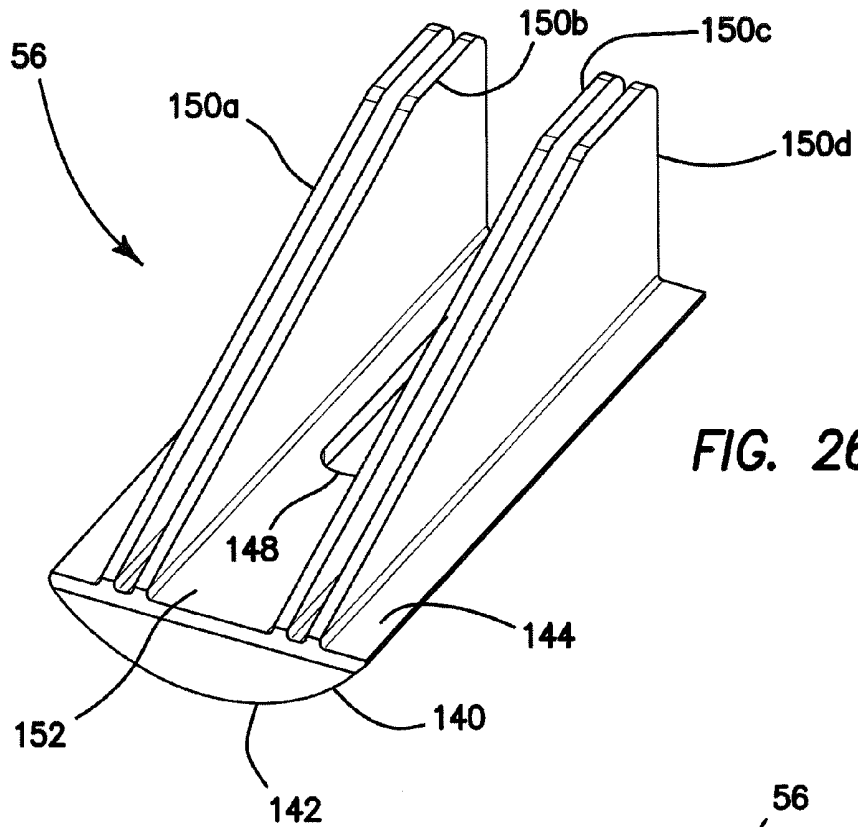

FIG. 26

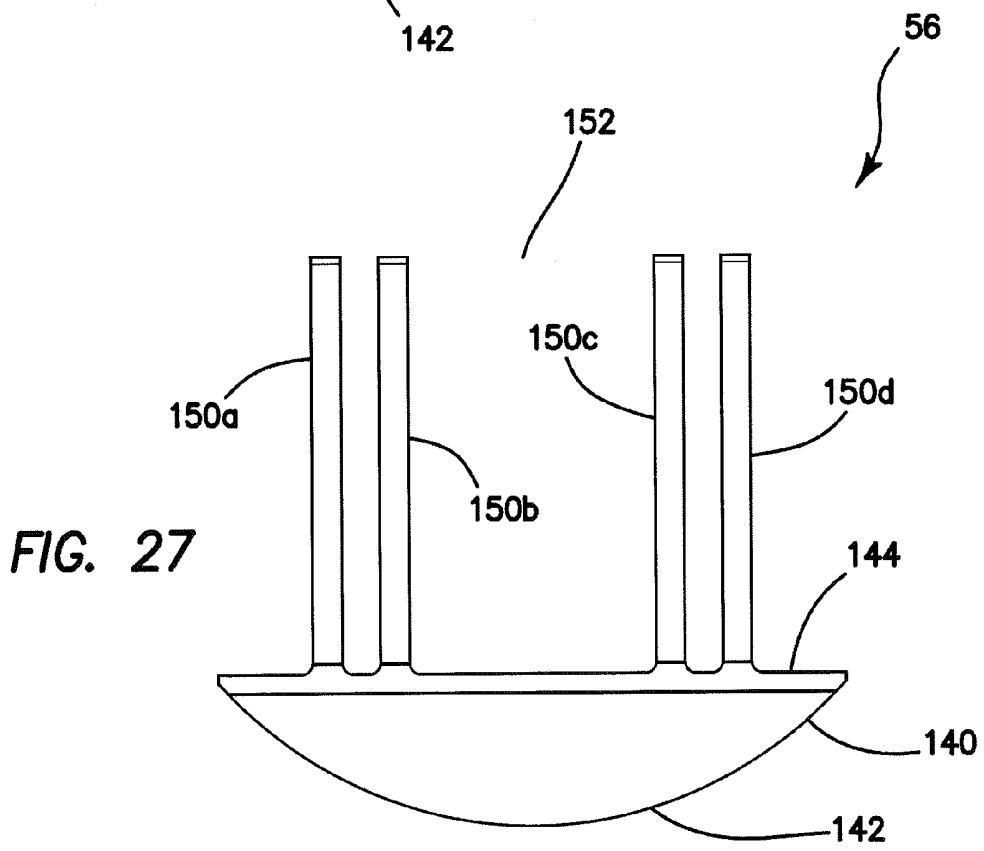
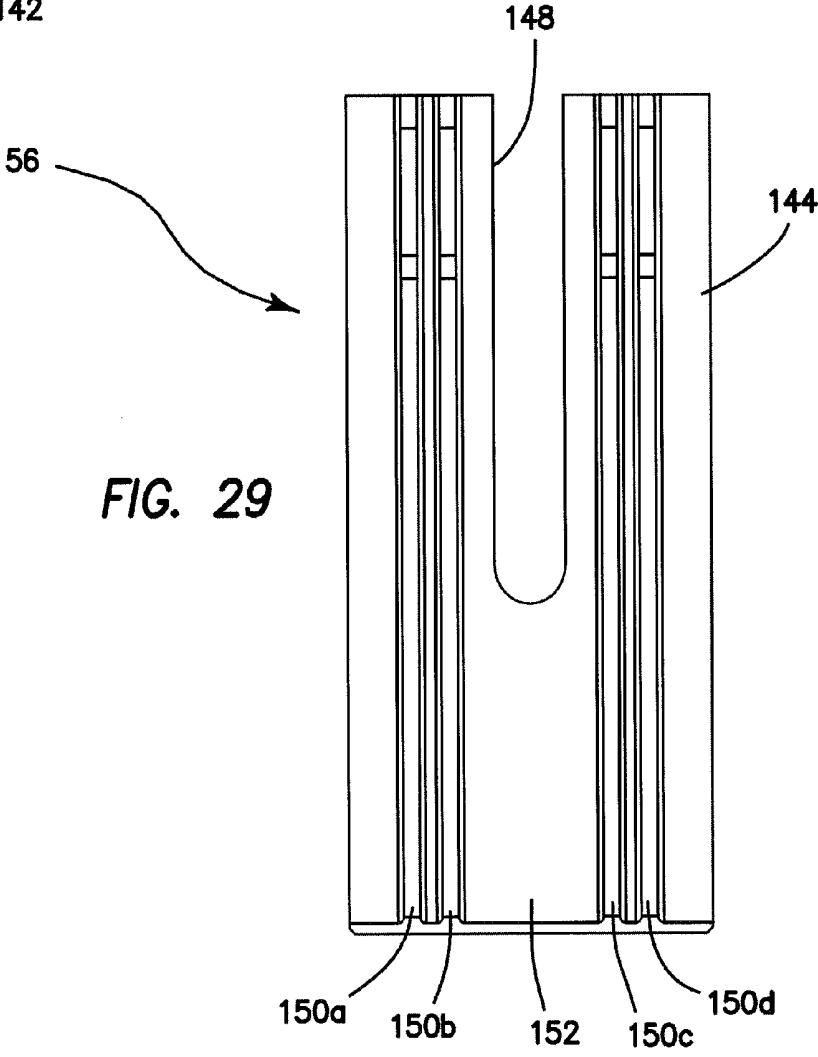
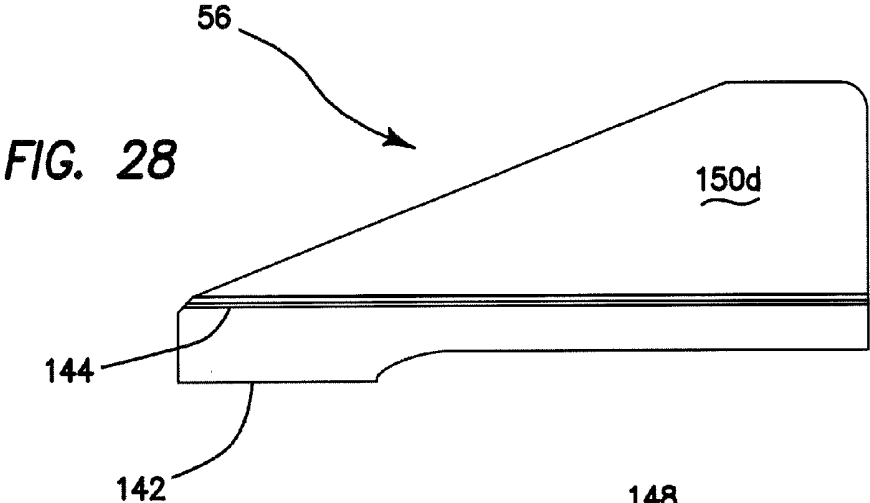
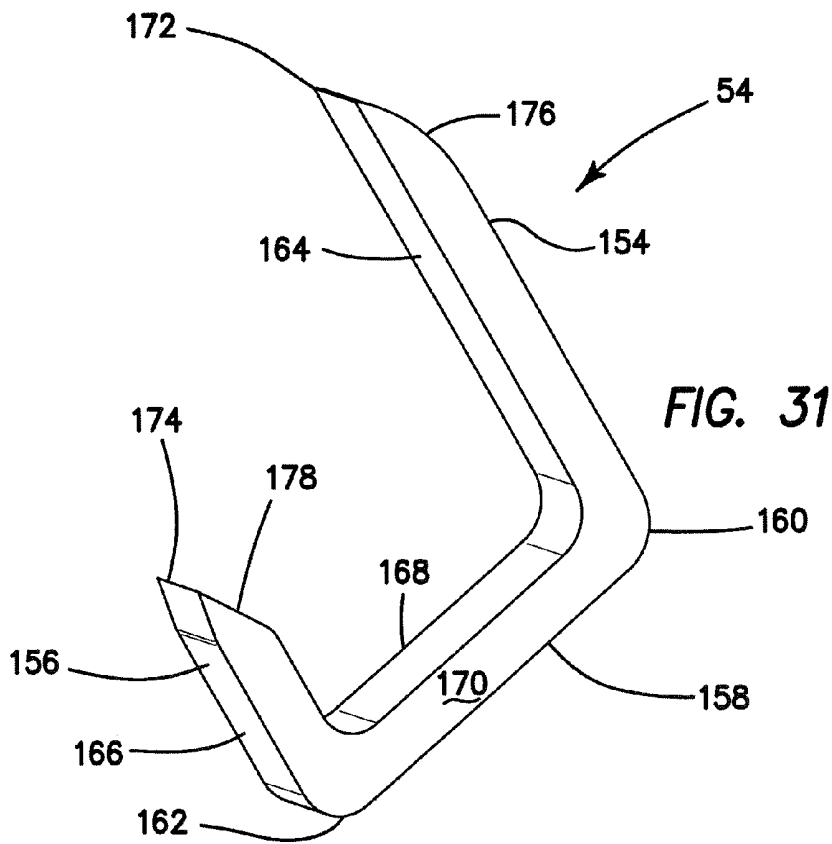
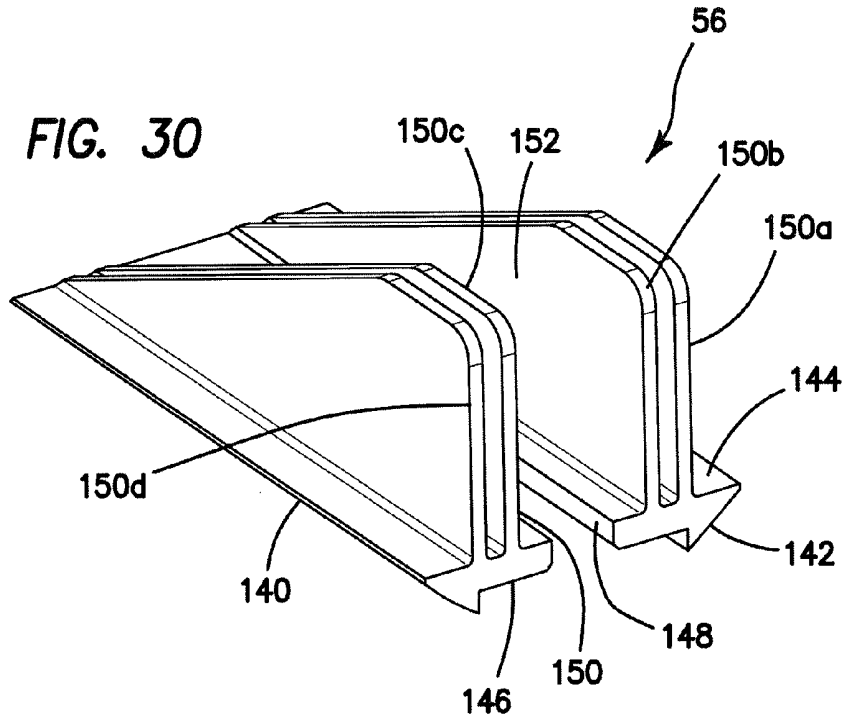

FIG. 27





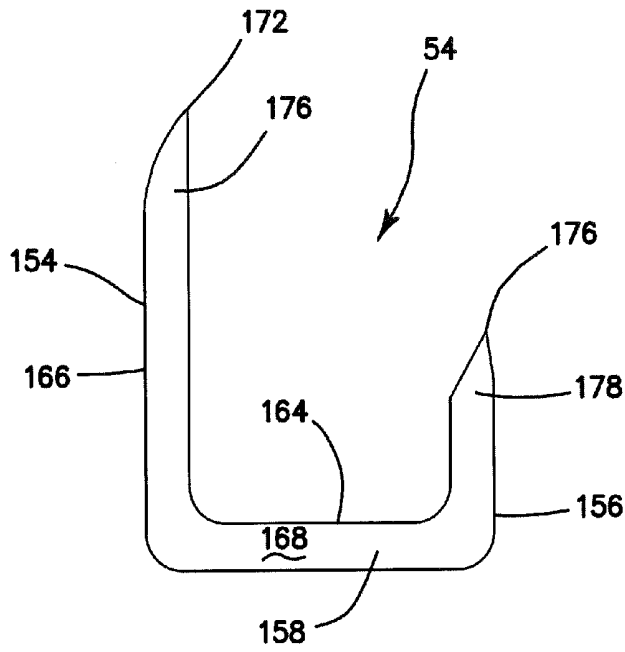

FIG. 32

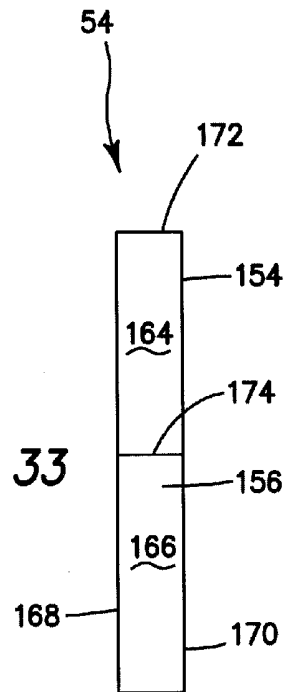

FIG. 33

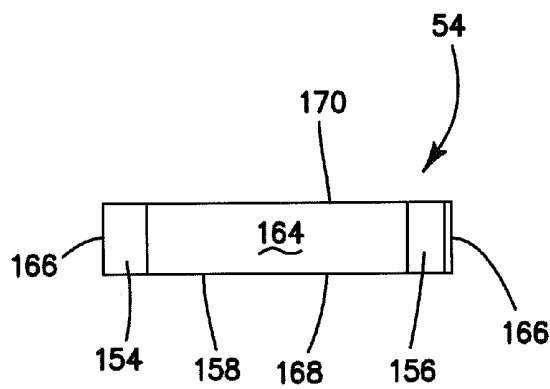
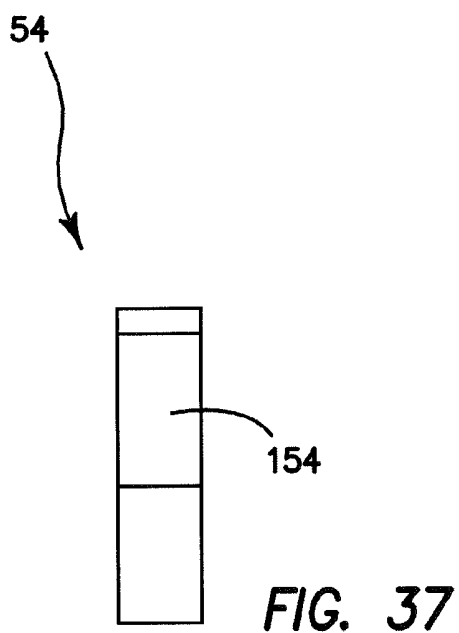
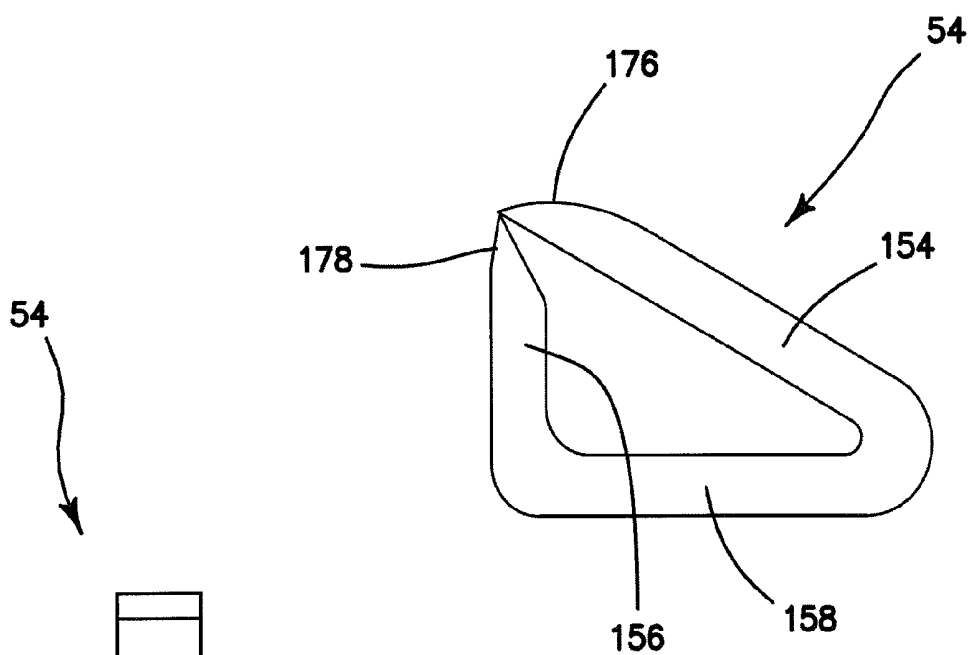
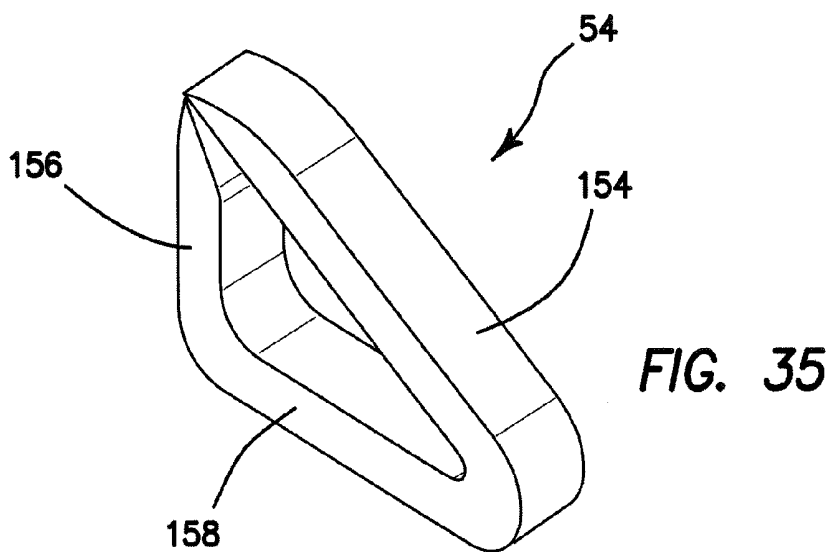
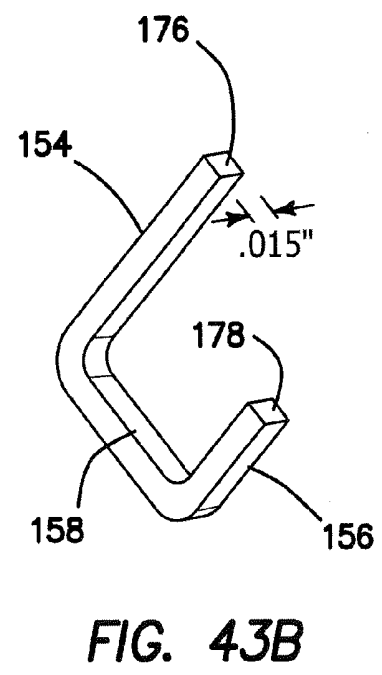
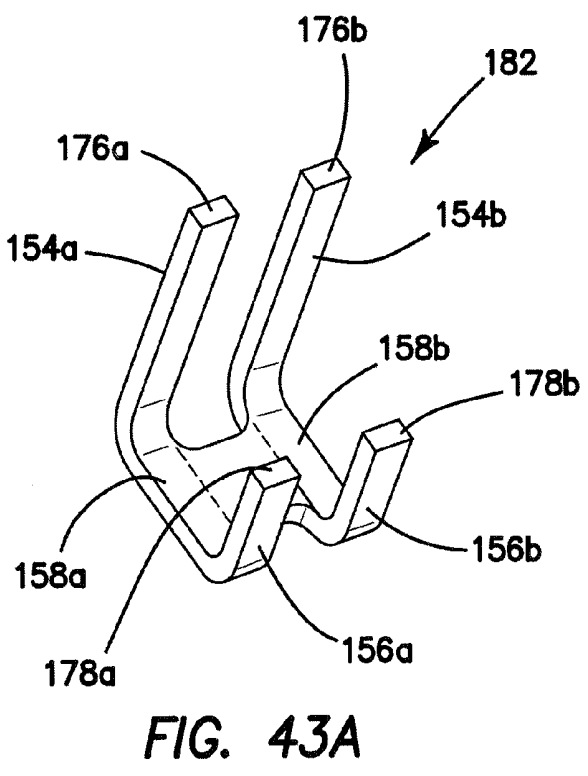
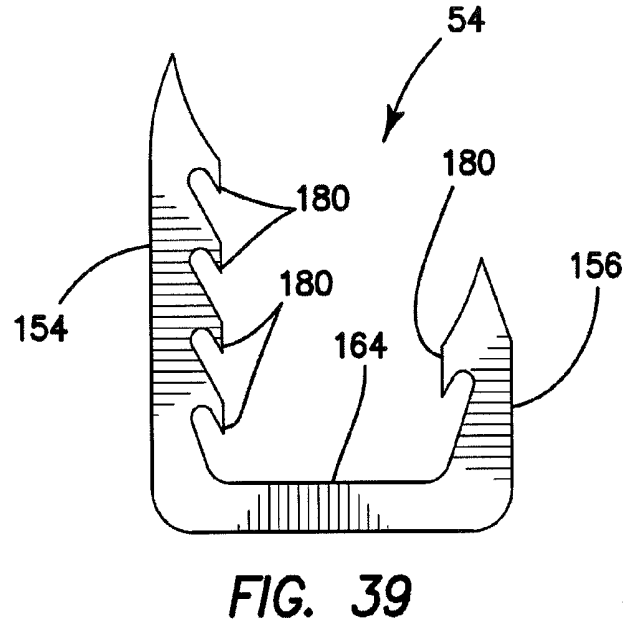
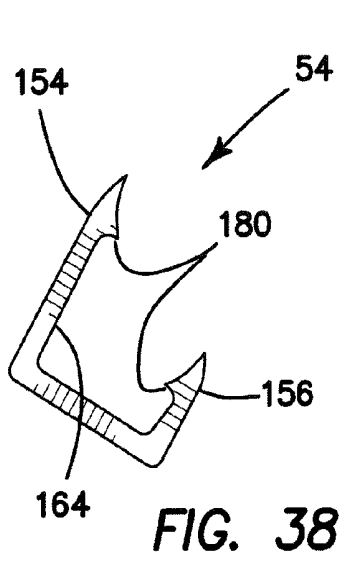
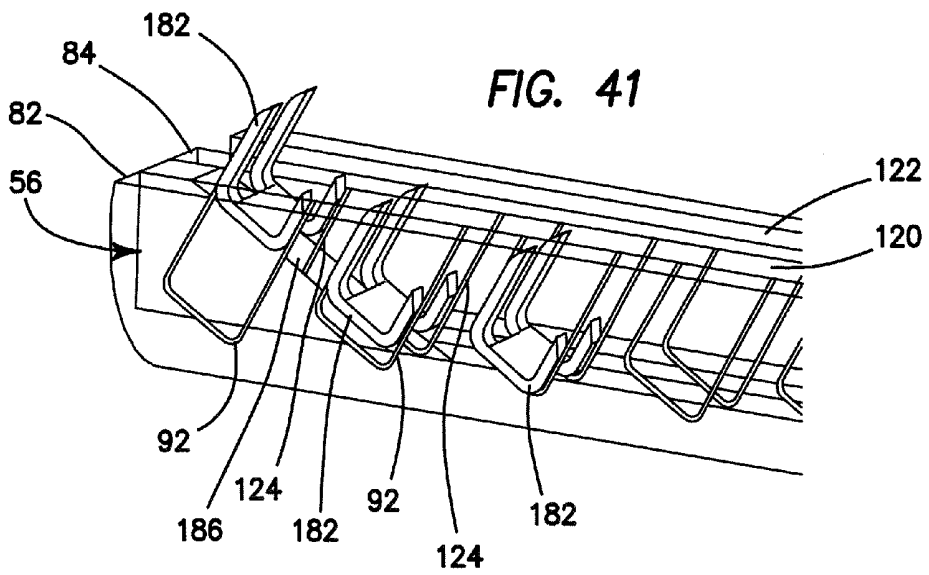
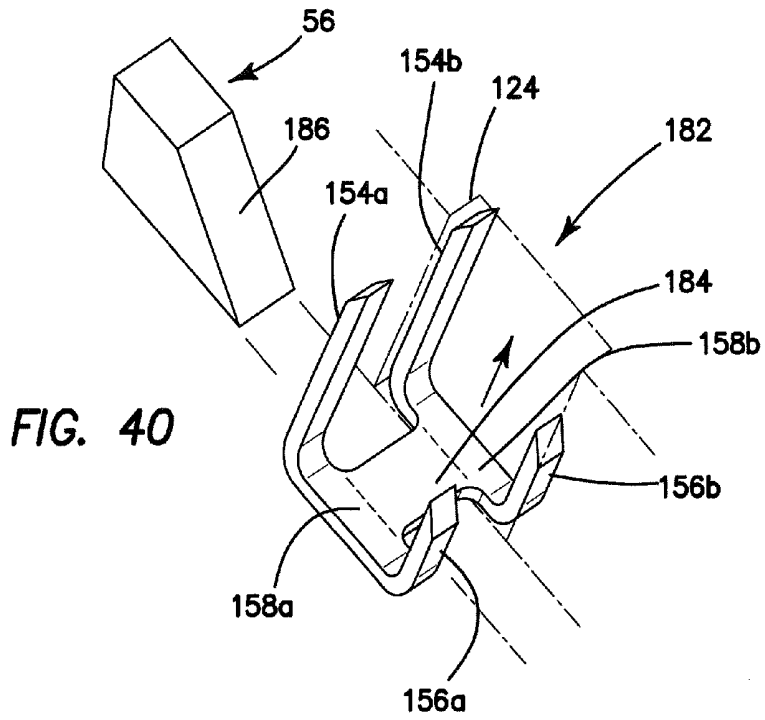
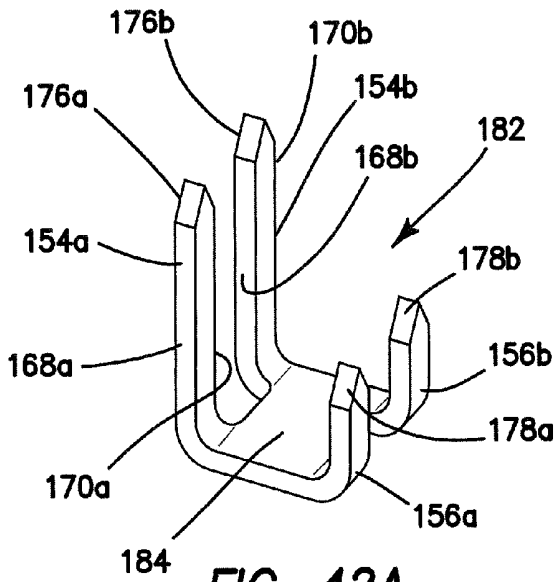

FIG. 34

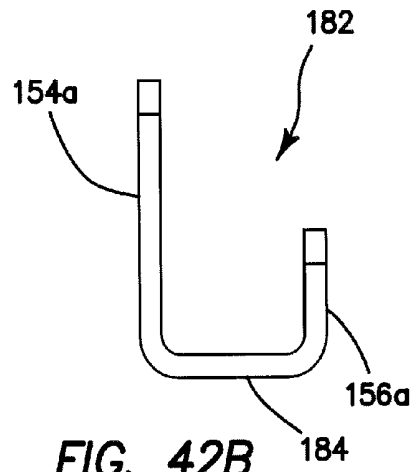



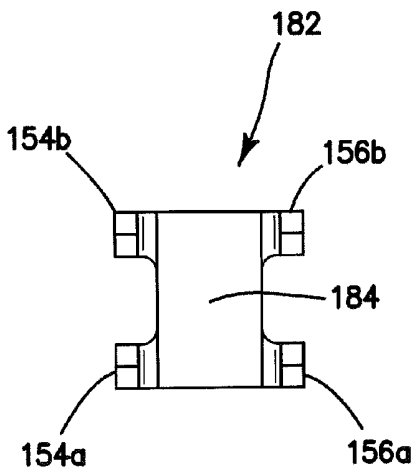



**FIG. 42A**



**FIG. 42B**



**FIG. 42C**

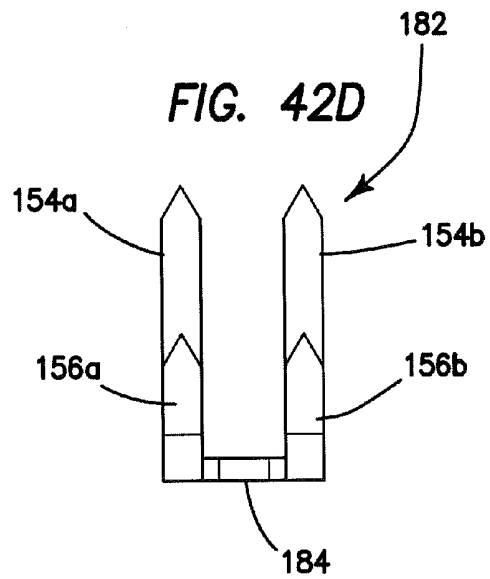

**FIG. 42D**

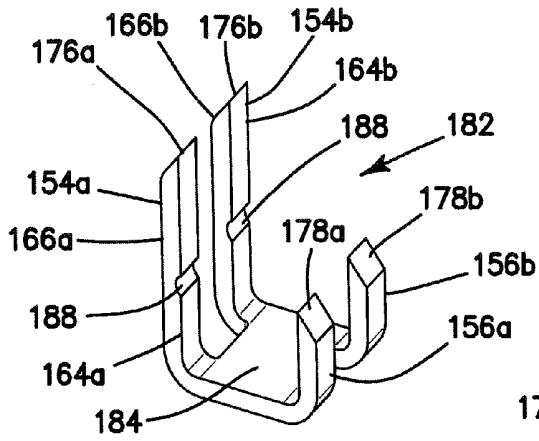

**FIG. 44A**

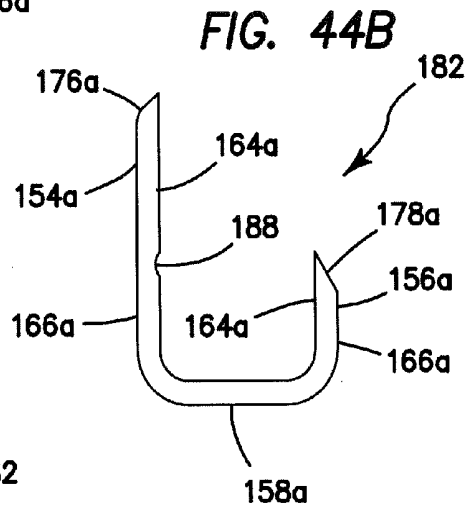

**FIG. 44B**

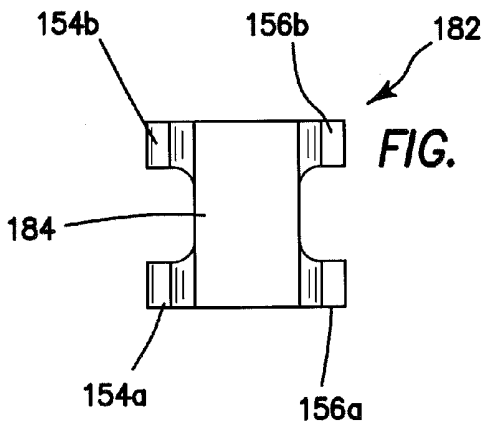

**FIG. 44C**

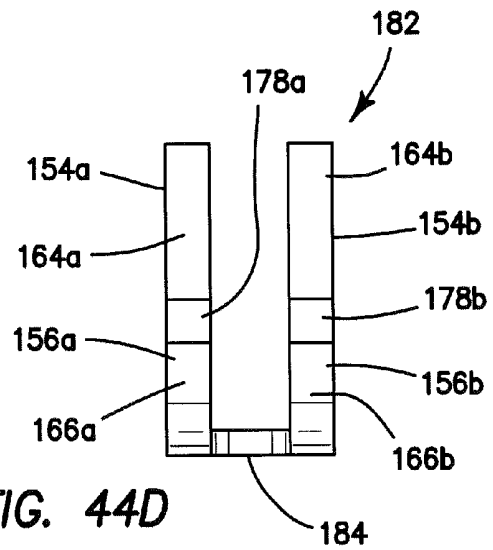

**FIG. 44D**

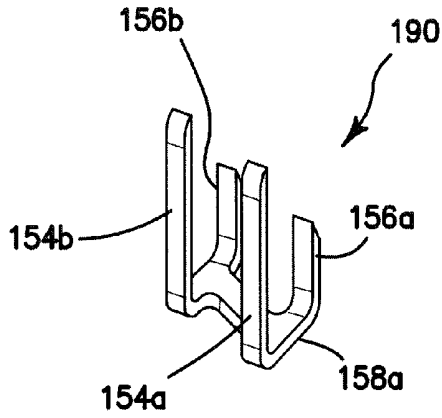

FIG. 45A

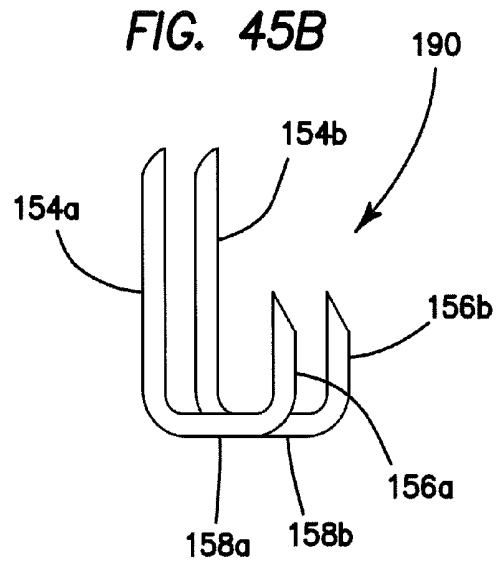

FIG. 45B

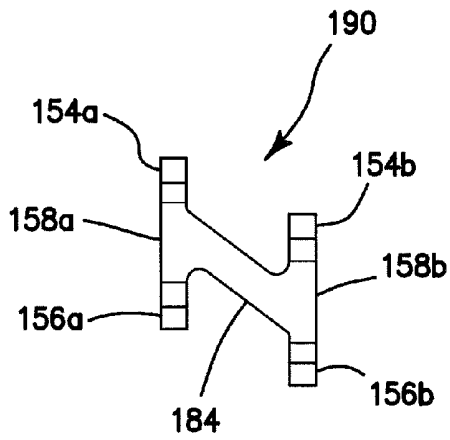

FIG. 45C

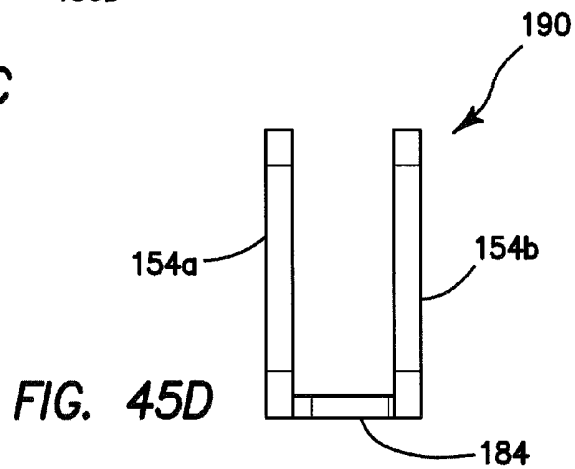
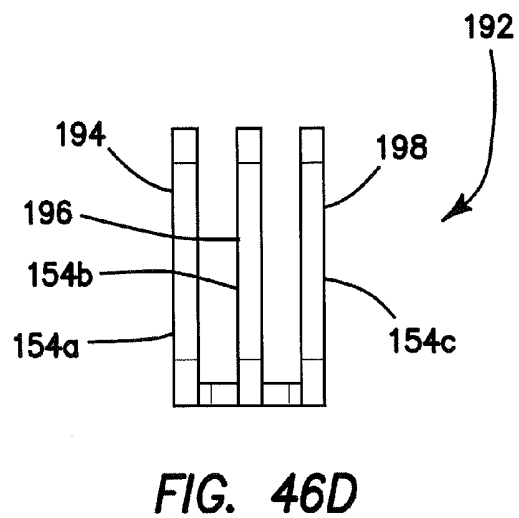
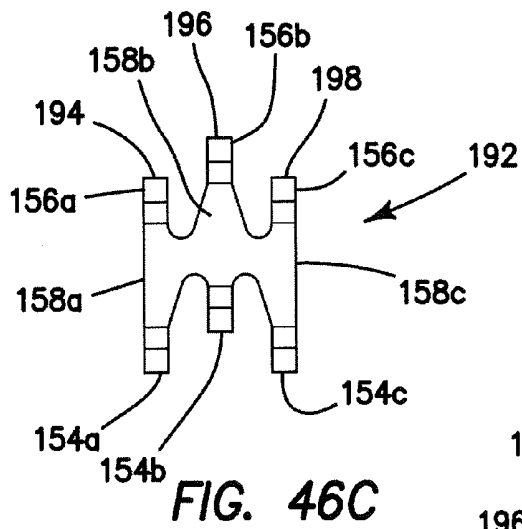
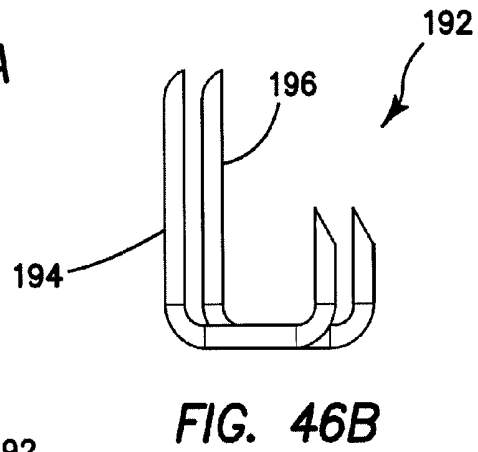
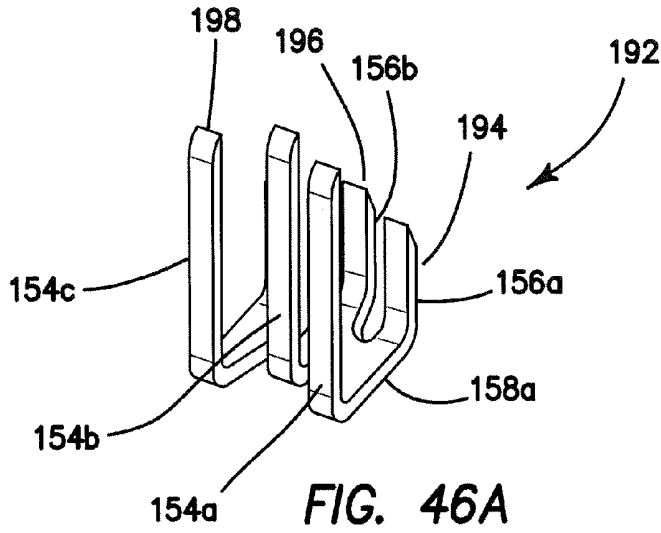
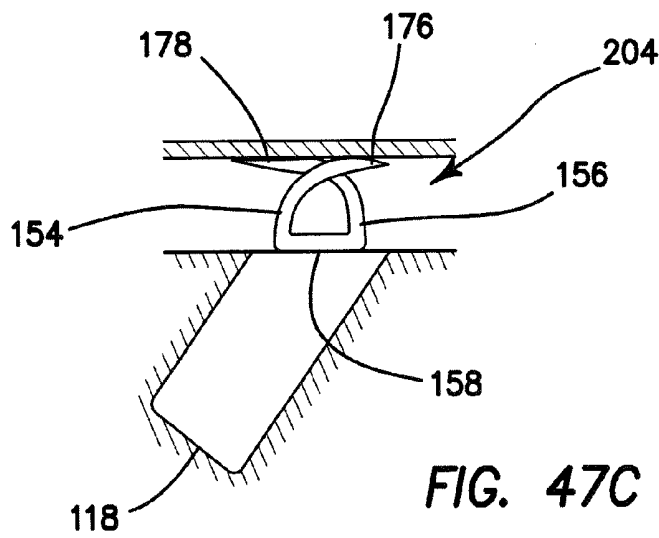
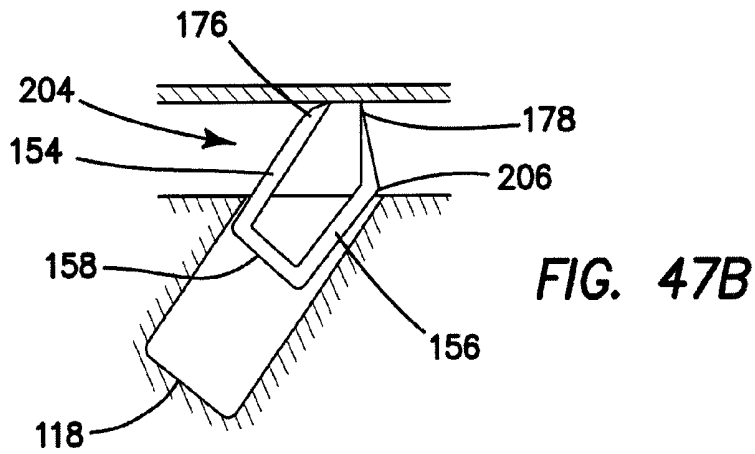
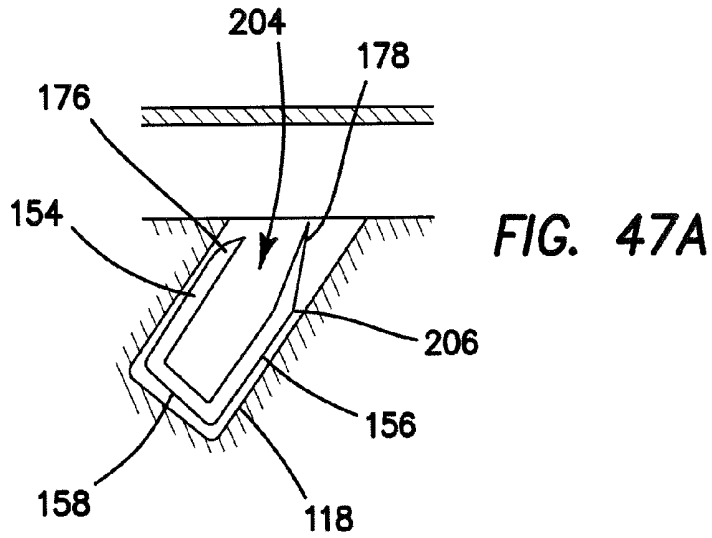

FIG. 45D





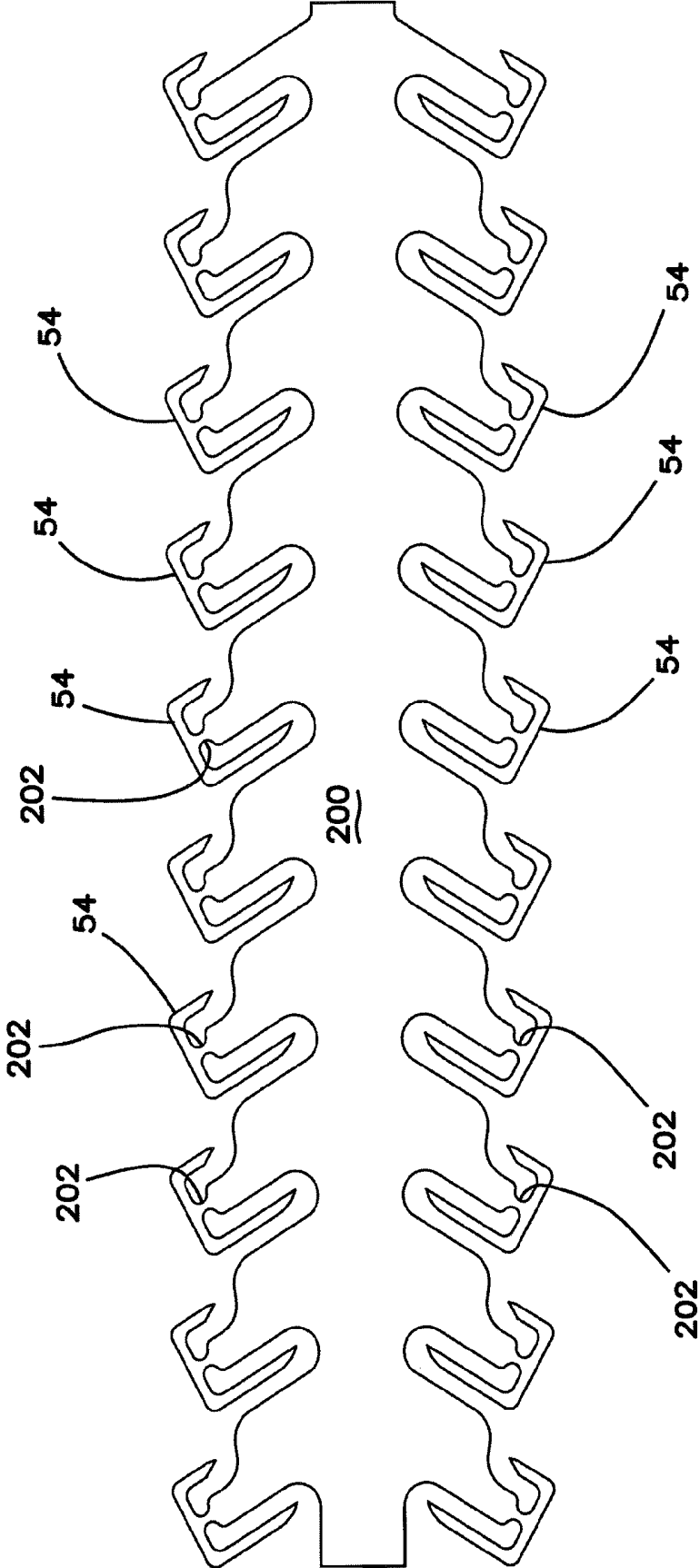

FIG. 48

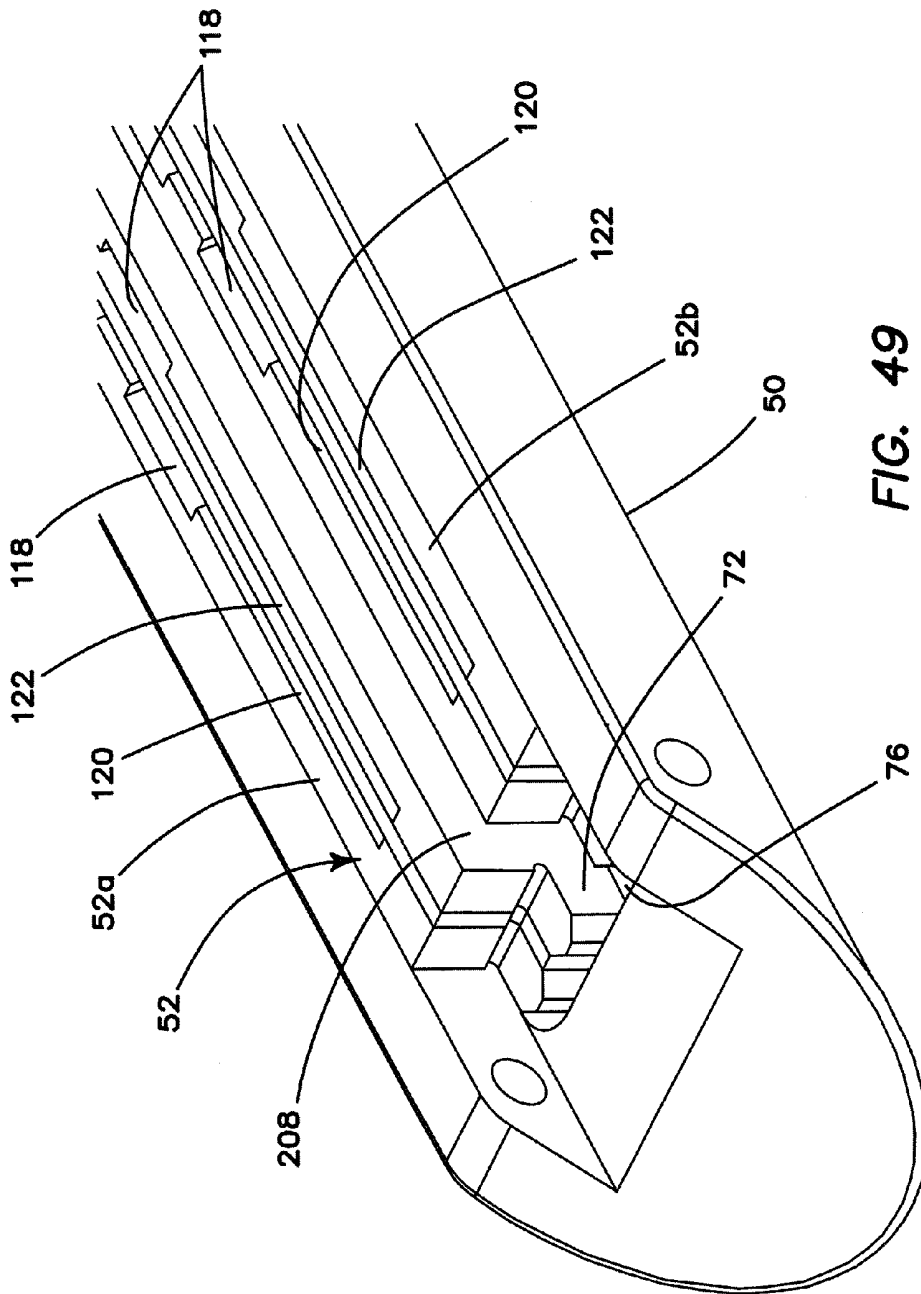
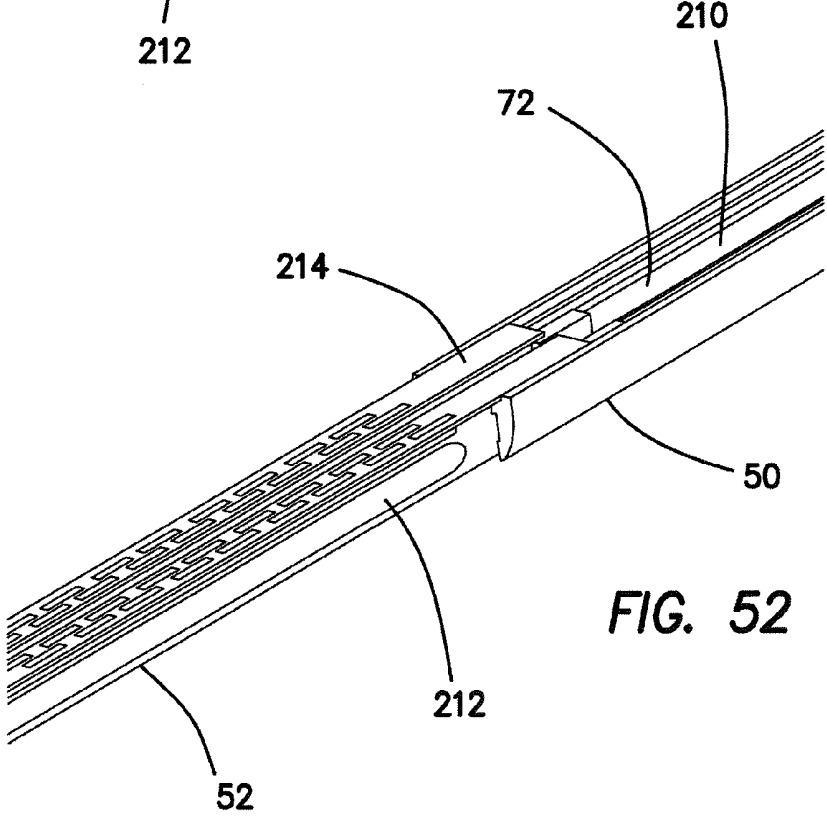
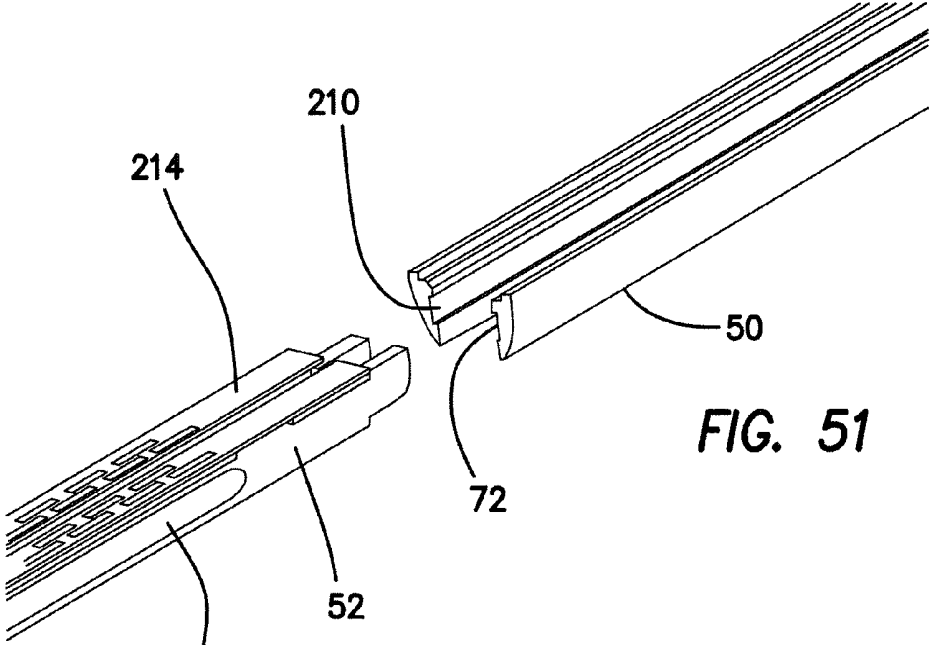

FIG. 49





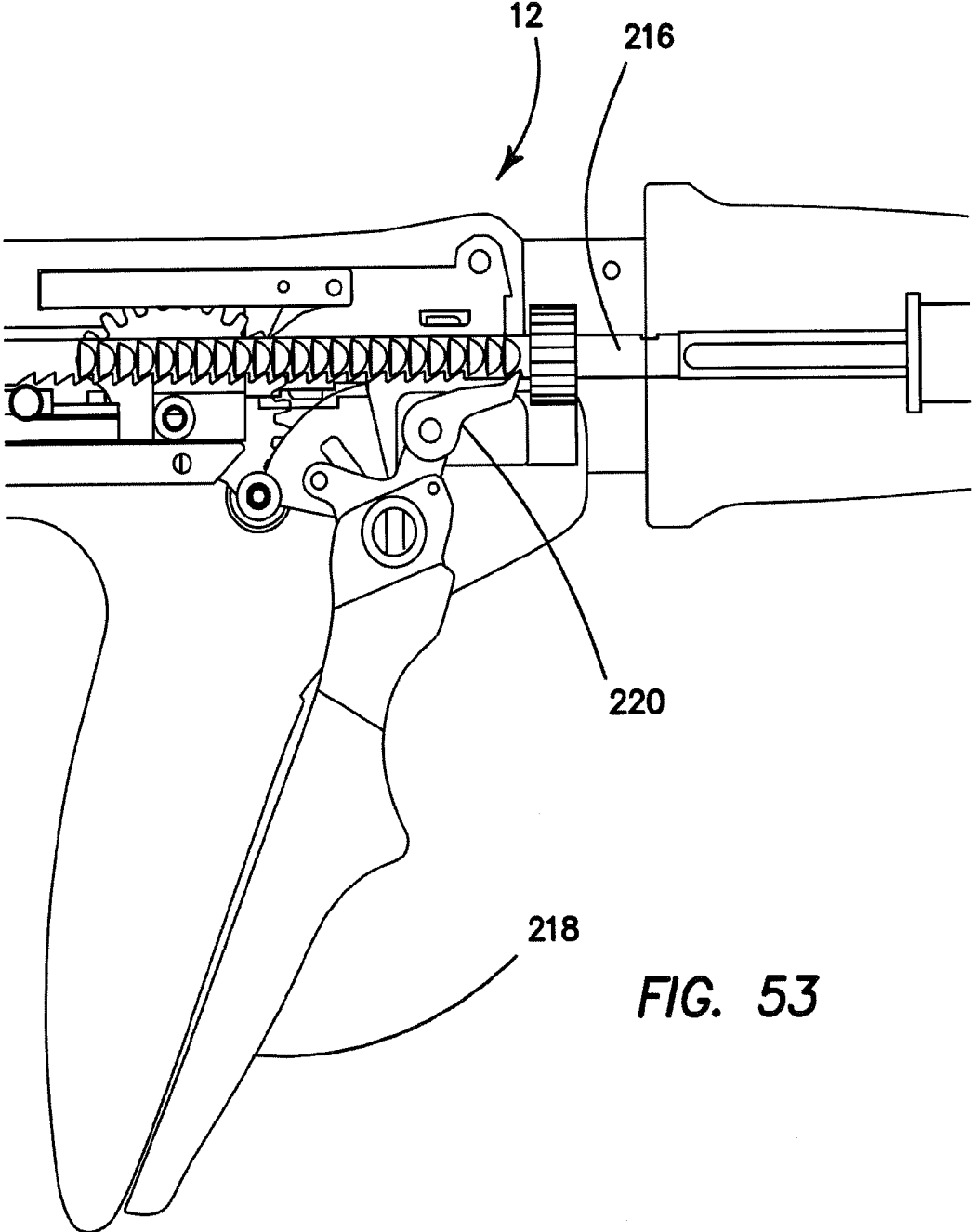

FIG. 53

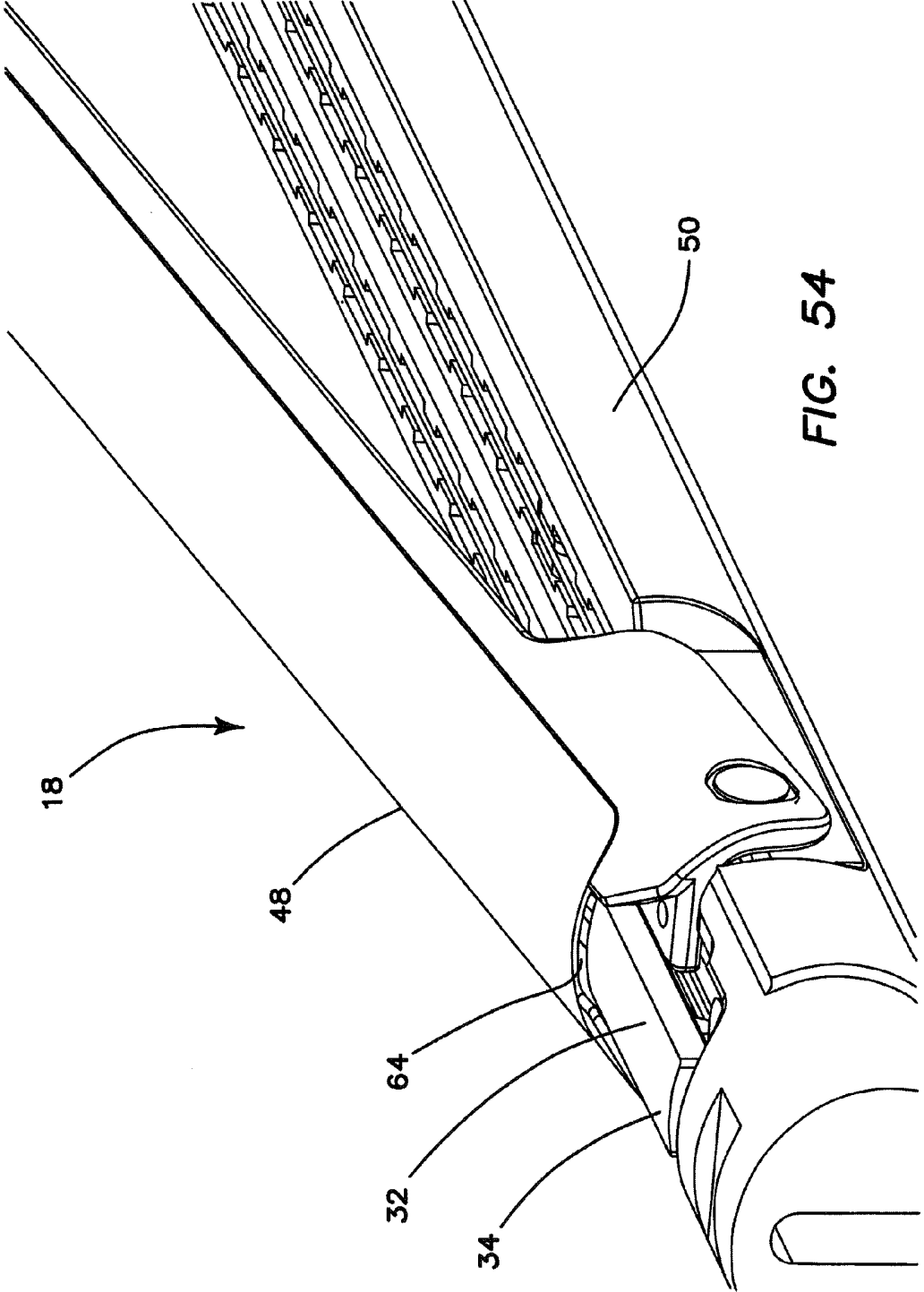

FIG. 54

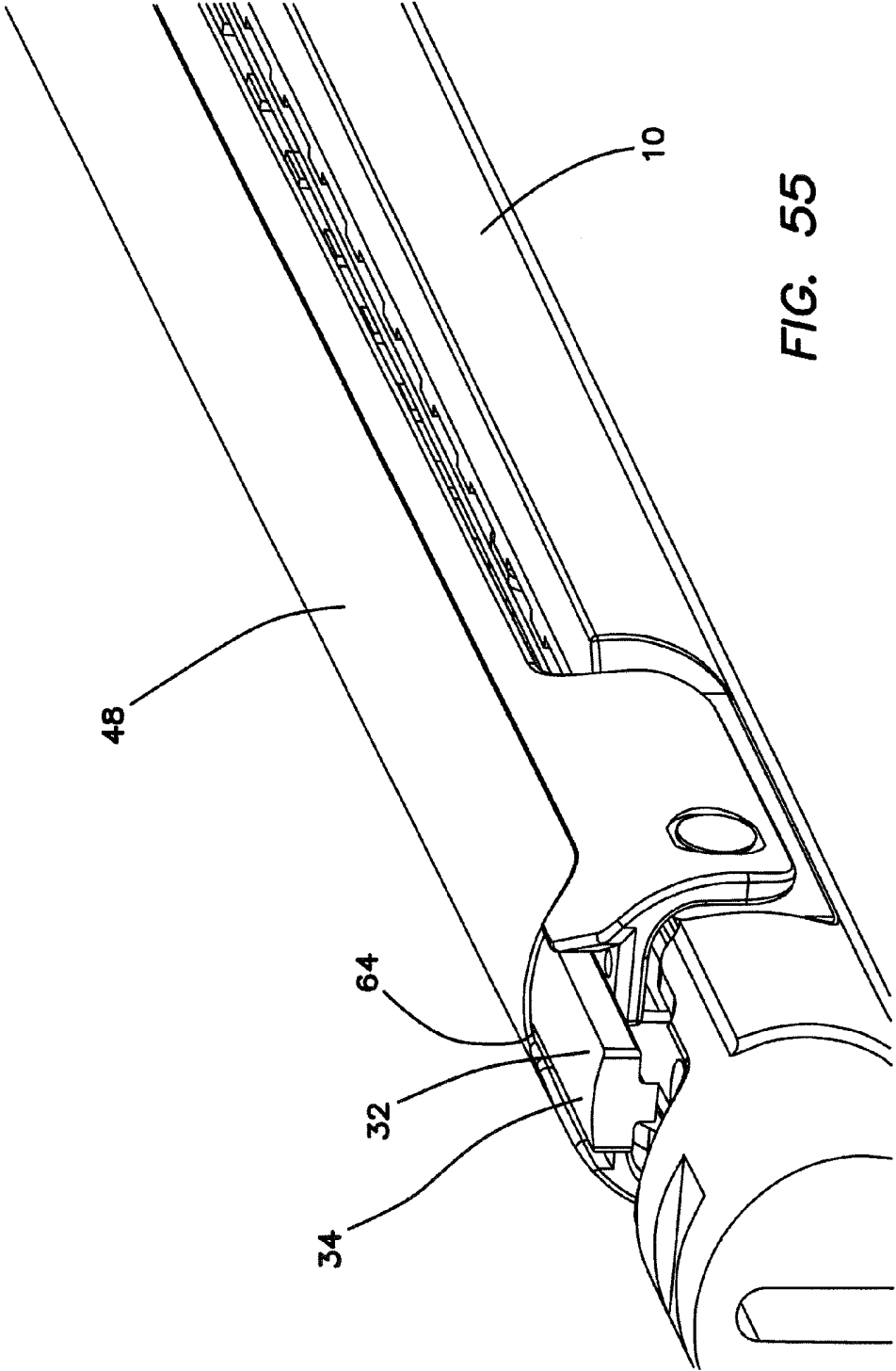
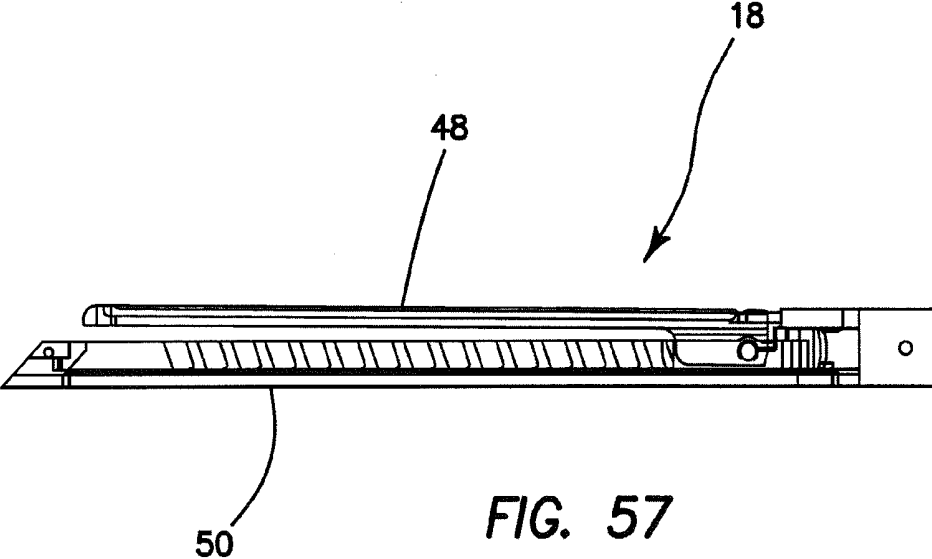
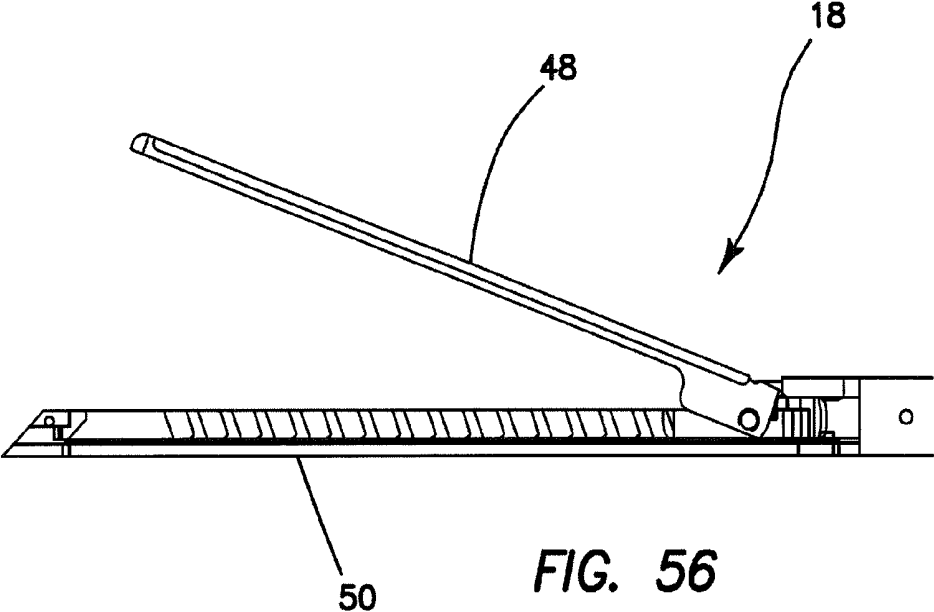

FIG. 55



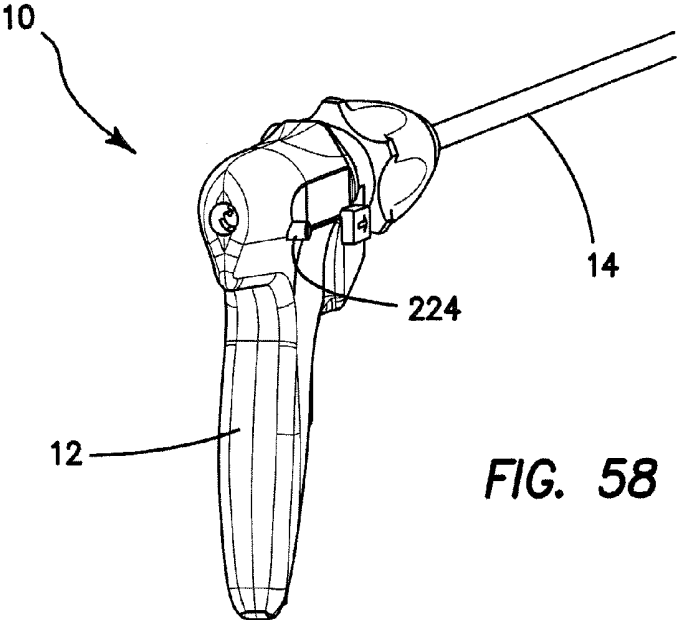

FIG. 58

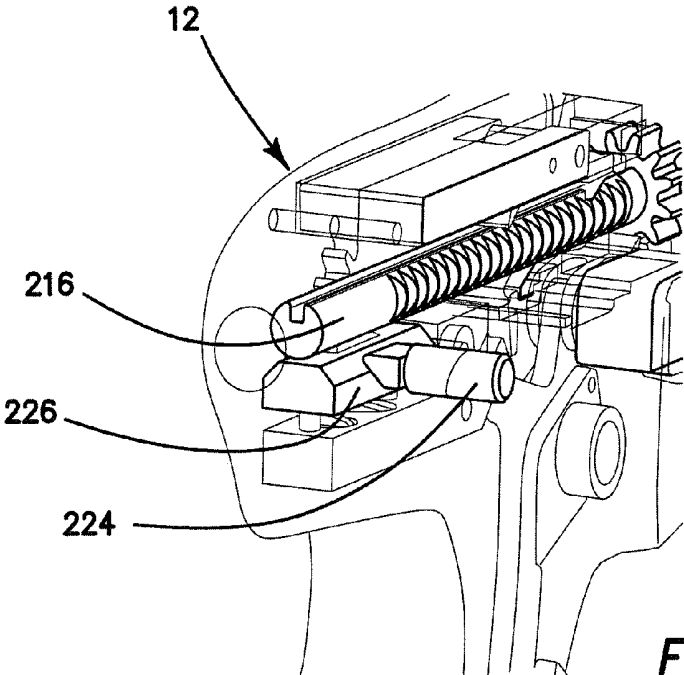
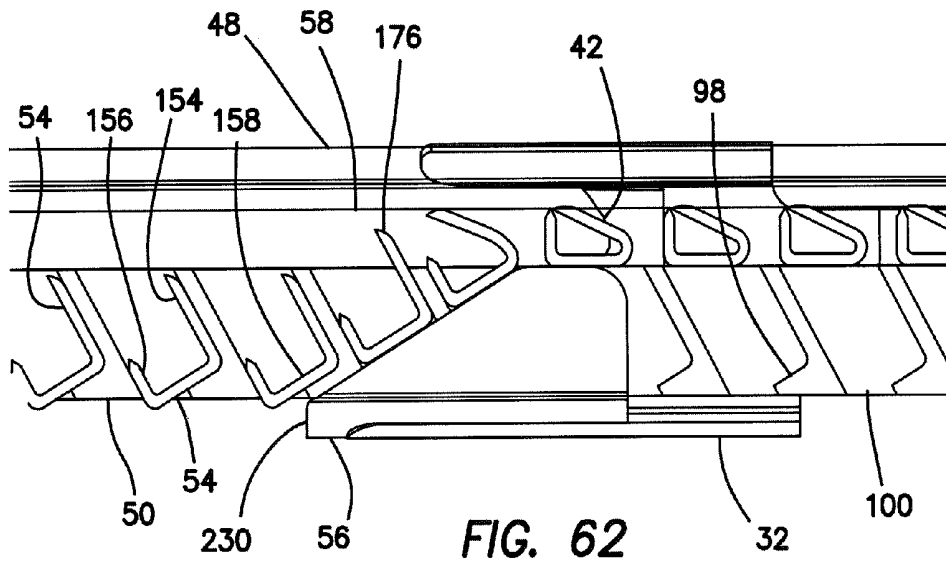
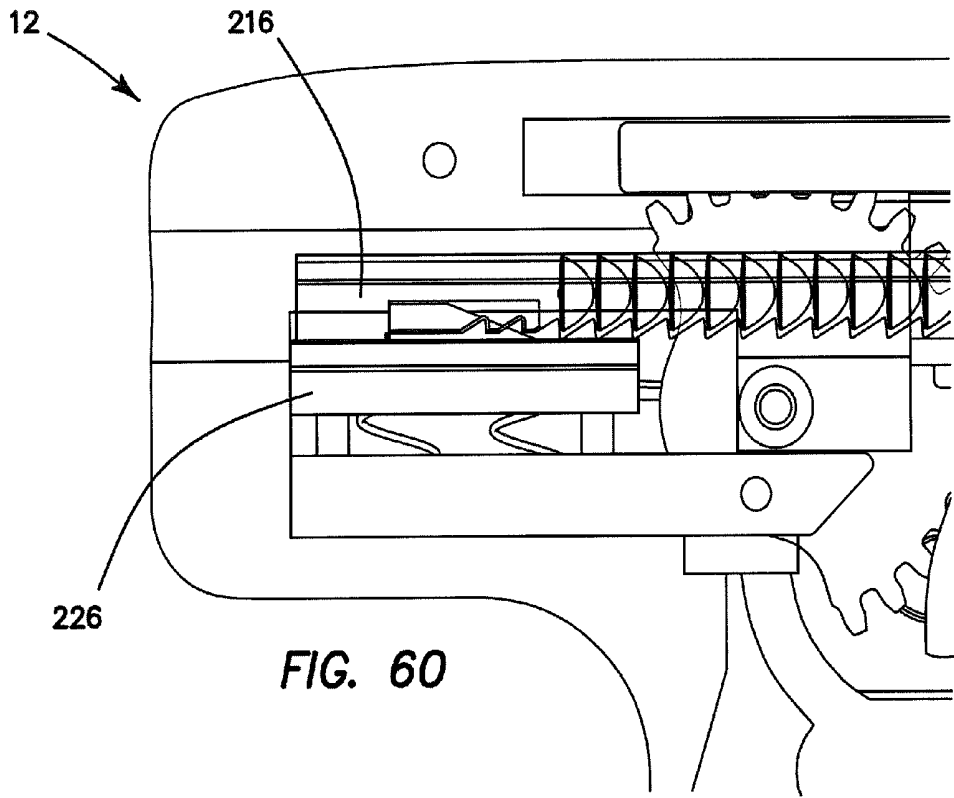

FIG. 59



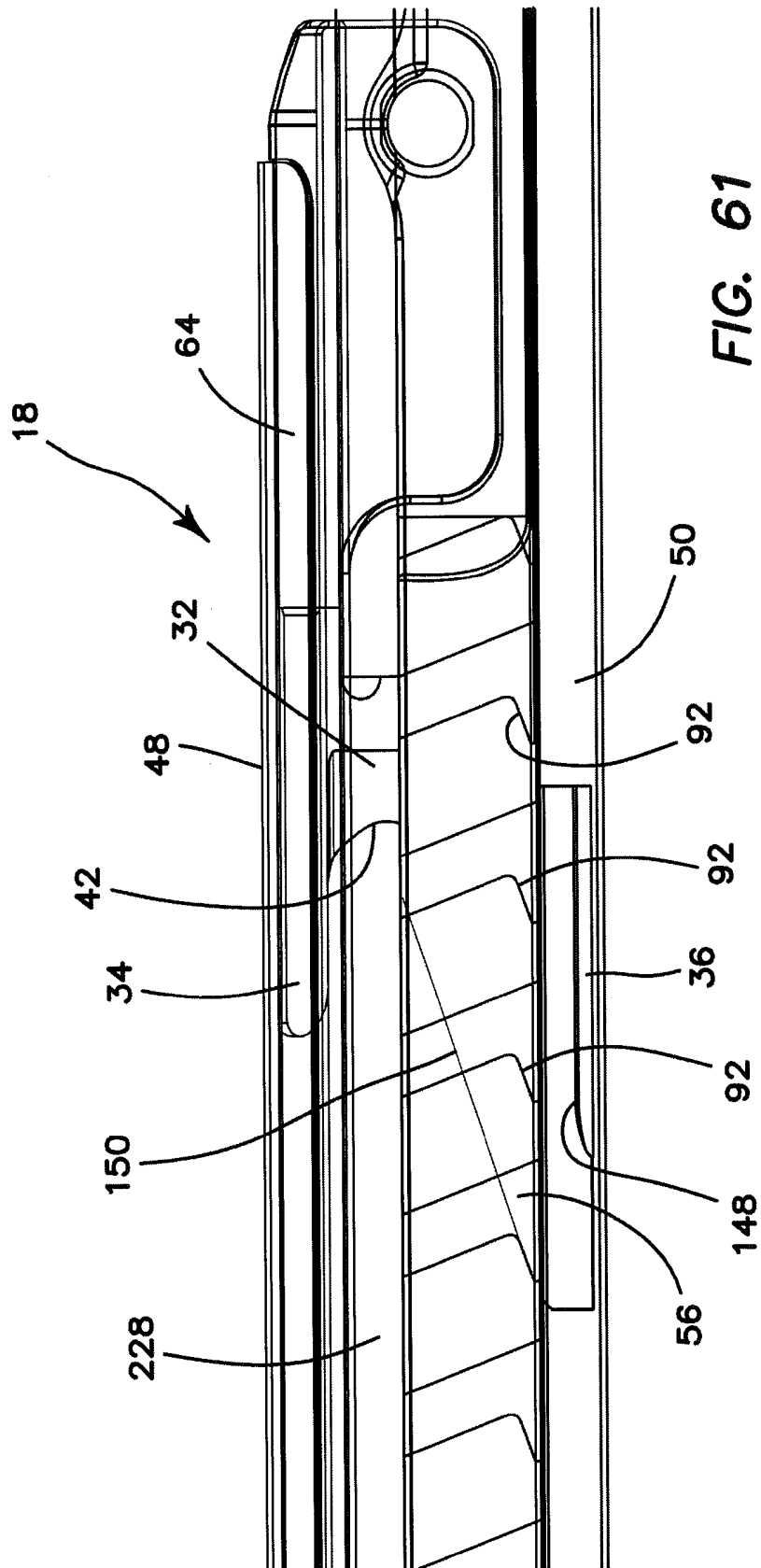

FIG. 61

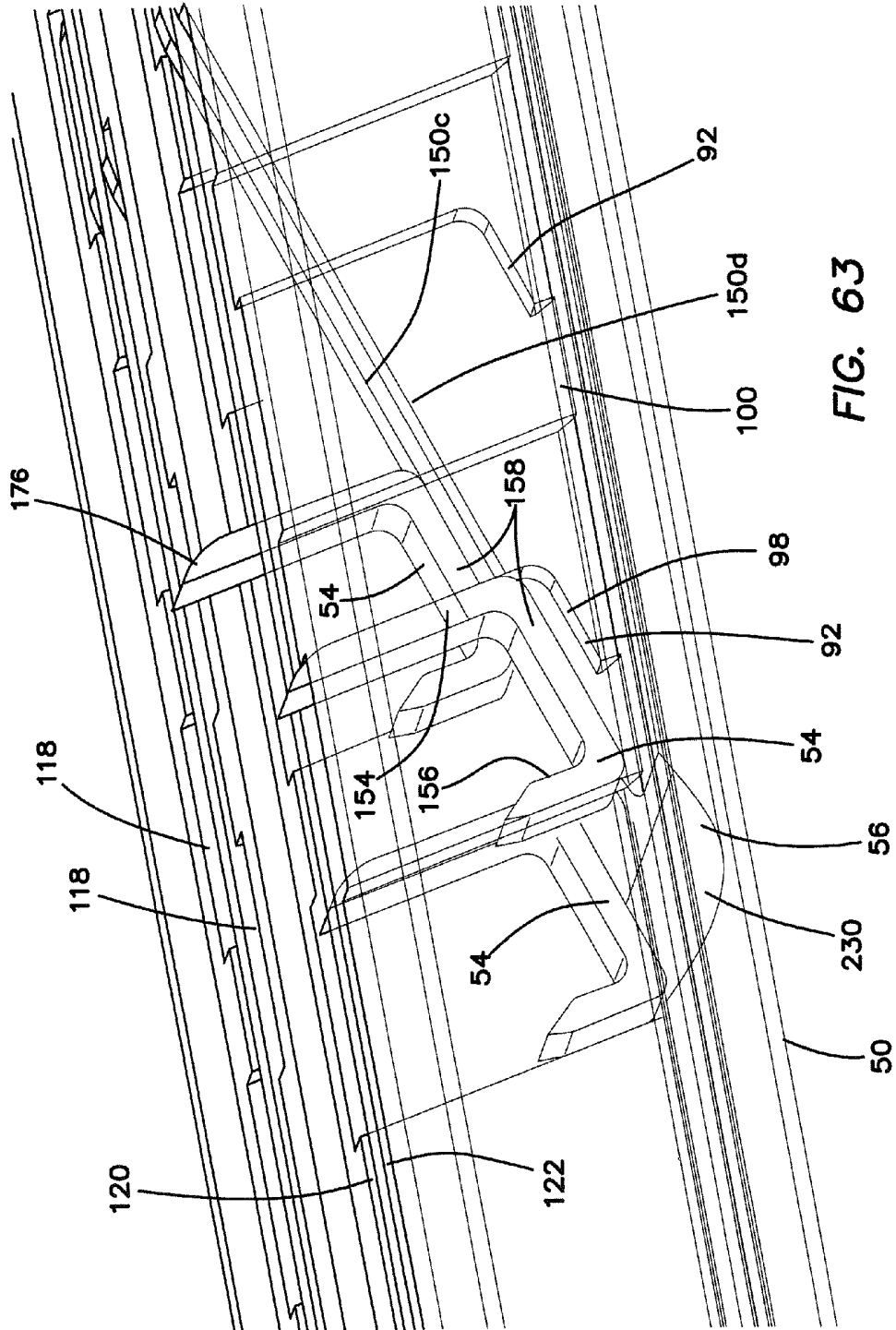

FIG. 63

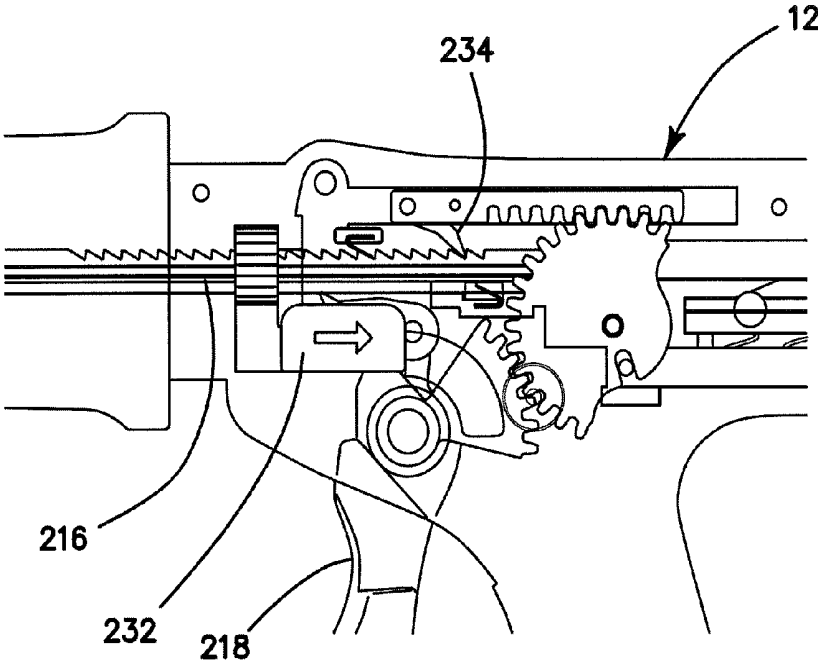

FIG. 64

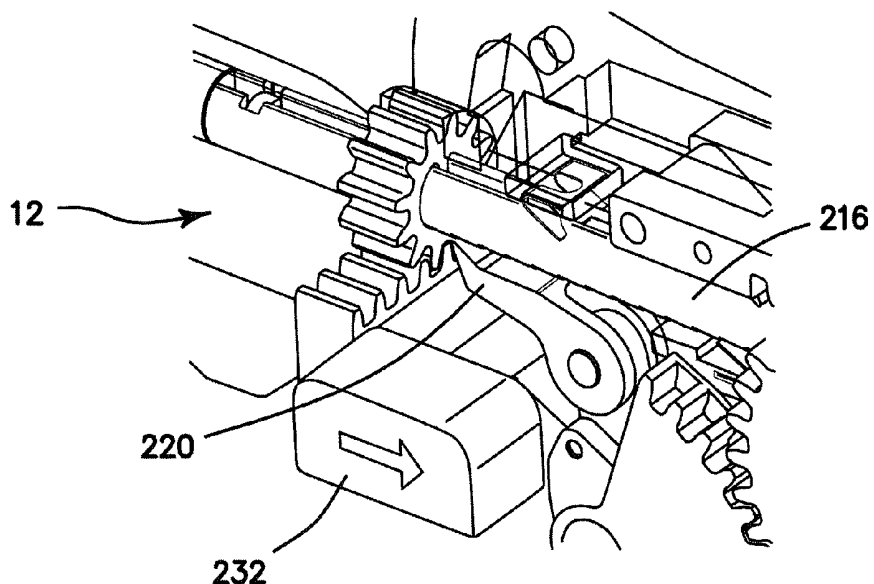
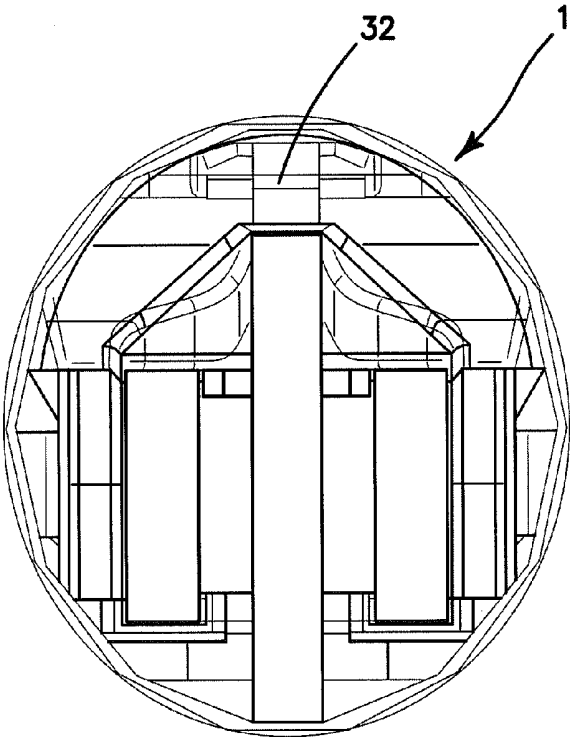
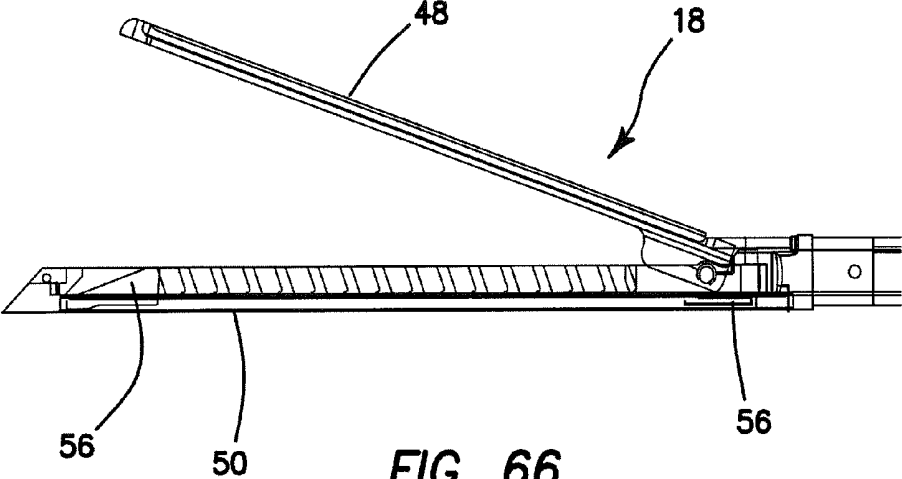

FIG. 65



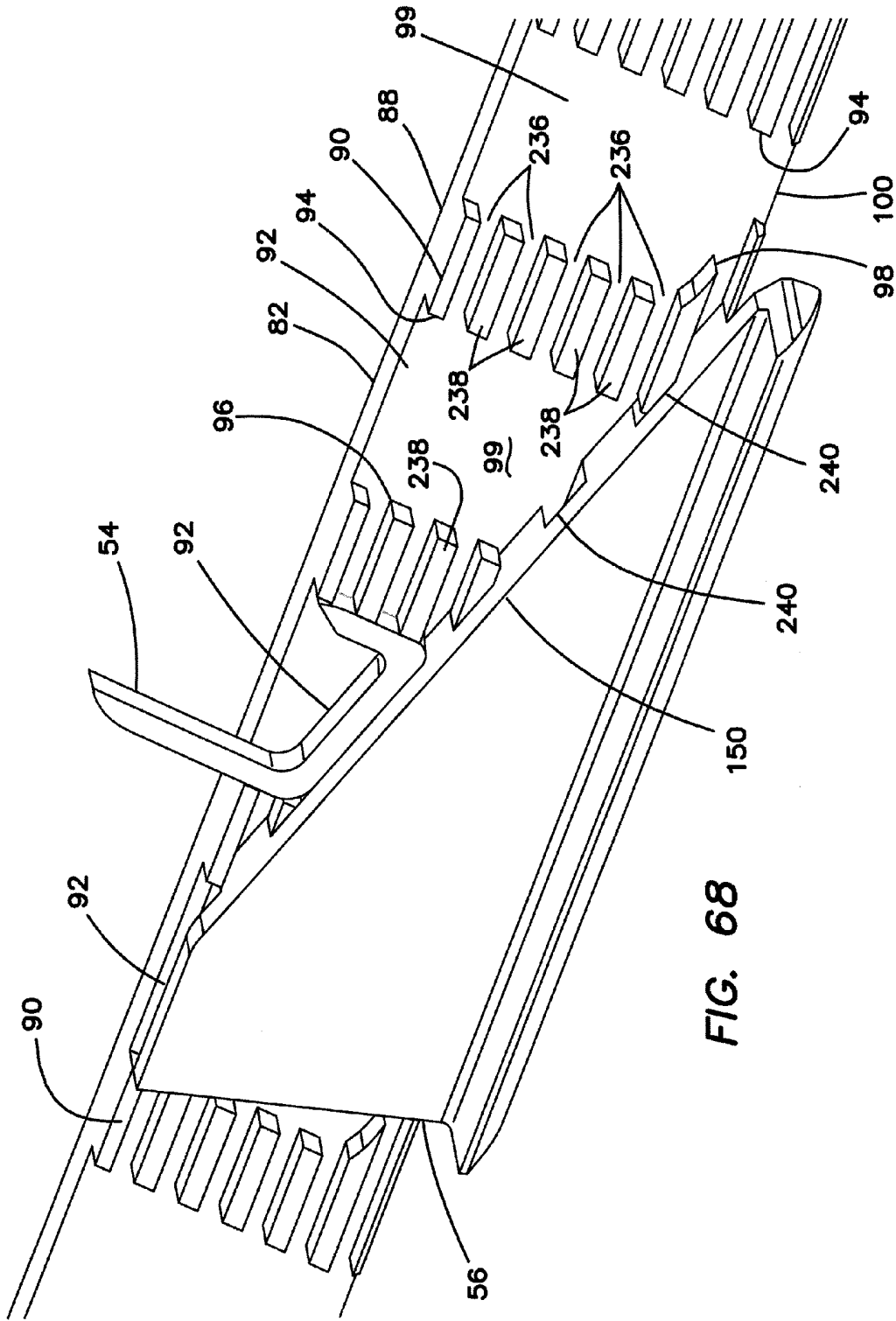

FIG. 68

## SURGICAL STAPLER WITH PARTIAL POCKETS

### CROSS-REFERENCE TO RELATED APPLICATIONS

**[0001]** This application claims priority to and benefit of U.S. Provisional Patent Application Ser. No. 61/785,100 filed on Mar. 14, 2013 entitled "Surgical stapler with partial pockets" which is incorporated herein by reference in its entirety.

### FIELD

**[0002]** This disclosure relates to surgical instruments, and more particularly, to surgical stapling instruments and staplers for sequentially applying a plurality of surgical staples to body tissue.

### BACKGROUND

**[0003]** A typical surgical stapler apparatus comprises a handle at a proximal end and two elongated jaw-like members joined together at a hinge at a distal end. The jaw-like members articulate to open and close to capture tissue between the jaw-like members. The user controls the device from the handle to open and close the jaw-like members, actuate deployment of staples and in general manipulate and control the device. One of the jaw members carries a disposable cartridge containing staples arranged in two or more rows. The other one of the jaw-like members comprises an anvil against which the staples are driven to deform the staple legs. Staples are driven out of the cartridge by a coming surface or slider that moves longitudinally against a plurality of laterally positioned pushers that push each staple out of the cartridge individually. The coming surface of the slider is angled to compliment the angular surface of the pushers. The cooperation between the angular surfaces of the pushers and the slider is a key step of the surgical stapling process. Misalignment can cause the staples to jam the device. Some staplers include a blade that follows the coming surface so as to cut the tissue between the two or more rows of delivered staples.

**[0004]** Surgical staplers are used in a variety of surgical techniques including laparoscopic and/or endoscopic or other minimally invasive surgical procedures in which the stapler is inserted through a cannula or tube positioned within a small incision in a patient's body. In laparoscopic, endoscopic or minimally invasive surgery, a trocar or cannula is inserted across body tissue of a patient to access a body cavity and to create a channel for the insertion of a camera, such as a laparoscope. The camera provides a live video feed capturing images that are then displayed to the surgeon on one or more monitors. Additional trocars are inserted to create additional pathways through which surgical instruments, including surgical staplers, can be inserted for performing procedures observed on the monitor. The targeted tissue location such as the abdomen is typically enlarged by delivering carbon dioxide gas to insufflate the body cavity and create a working space large enough to accommodate the scope and instruments used by the surgeon. The insufflation pressure in the tissue cavity is maintained by using specialized trocars having seals that prevent the insufflation gas from escaping and collapsing the surgical working space. Laparoscopic surgery offers a number of advantages when compared with an open procedure. These advantages include reduced pain and hemorrhaging and shorter recovery times.

**[0005]** As laparoscopic surgery evolves to become even more minimally invasive with incisions and cannula diameters becoming smaller and smaller, surgical staplers for use in laparoscopic/endoscopic procedures must be designed to fit within the small lumen of a cannula. Generally, a surgical stapler is inserted into a cannula such that the jaw-like members are in a closed orientation to inside the patient where the jaw-like members are opened to grasp and staple tissue. The handle of the stapler resides outside of the patient in control of the surgeon user. A portion of the shaft of the stapler between the jaw-like members and the handle is long enough to extend from outside the patient to inside the patient. During the surgical procedure, the elongate shaft of the stapler resides inside the cannula into which it was inserted. The distal jaw-like members include many components such as an anvil for forming staples, a staple cartridge with a plurality of staples, a coming surface such as a slider, pushers, a blade and other components which must all be small enough to fit through a small diameter cannula and made to function reliably and repeatedly from outside the patient. While conventional laparoscopic staplers are approximately 12 millimeters in diameter, the present invention provides a surgical stapler designed to fit inside a cannula having a diameter as small as approximately 5-10 mm.

### SUMMARY

**[0006]** According to one aspect of the invention, a surgical stapler is provided. The surgical stapler includes a handle assembly and a cartridge assembly removably connected to the handle assembly. The cartridge assembly has a proximal end and a distal end and includes a jaw assembly at the distal end. The jaw assembly includes a first jaw and a second jaw. The first jaw has an anvil surface and the second jaw has a top surface. The second jaw is movable relative to the first jaw and the jaw assembly includes a closed position in which the anvil surface is adjacent to a top surface and a gap is defined between the top surface and the anvil surface. The second jaw includes a first surface and a second surface substantially parallel to each other and perpendicular to the top surface. The first surface and second surface defines a first slot between the first surface and the second surface extending along a length of the second jaw. The first slot has a slot width. The first surface includes a plurality of recesses formed into the first surface. Each recess includes a recessed wall, a front sidewall, and a rear sidewall. The second jaw includes a plurality of staple pockets. Each staple pocket is defined by the recessed wall, front sidewall, rear sidewall, a bottom wall, second surface and an opening to the top surface of the second jaw. The bottom wall is formed as part of the first surface, second surface or other surface. An actuator is coupled to the handle assembly. The cartridge assembly includes a first coming surface having a thickness. The first coming surface is movable by the actuator within the first slot and along a length of the second jaw. A plurality of staples is positioned in the plurality of staple pockets. Each staple has a staple width and is positioned within a pocket such that a portion of the staple width resides within the first slot and a portion of the staple width is located and supported by the recess in the first surface. The bottom wall is formed as part of the first surface, second surface or other surface and configured such that the first coming surface contacts a portion of the staple. With translation of the first coming surface within the first slot, the first coming surface passes through one or more staple pock-

ets making contact with that portion of the staple width resident within the first slot to urge the staple out of the opening and against the anvil surface.

**[0007]** According to another aspect of the invention, a surgical stapler is provided. The surgical stapler includes a handle assembly and a cartridge assembly removably connected to the handle assembly. The cartridge assembly includes a proximal end and a distal end. A jaw assembly is located at the distal end of the cartridge assembly. The jaw assembly has a longitudinal axis and includes a first jaw connected to a second jaw. The first jaw includes an anvil surface that is a smooth and flat without any staple-forming pockets. The second jaw has a top surface. The second jaw is movable relative to the first jaw such that the jaw assembly includes a closed position in which the anvil surface is adjacent to a top surface and a gap is defined between the top surface and the anvil surface. The second jaw includes a plurality of staple pockets. Each staple pocket has a longitudinal axis and an opening at the top surface. An actuator is coupled to the handle assembly. At least one camming surface is movable by the actuator within the second jaw and along a length of the second jaw. A plurality of staples is positioned inside the staple pockets. Each staple includes at least a first leg and a second leg interconnected by base and an open configuration for penetrating tissue and a closed configuration for retaining tissue. The plurality of staples is located inside the staple pockets in an open configuration. With the jaw assembly in a closed position, translation of the camming surface along the second jaw ejects the staples from the staple pockets toward the anvil surface of the first jaw to deform the staples from an open configuration against the anvil surface to a closed configuration.

**[0008]** According to another aspect of the invention, a surgical stapler is provided. The surgical stapler includes a handle assembly and a cartridge assembly removably connected to the handle assembly. The cartridge assembly includes a proximal end and a distal end. A jaw assembly is located at the distal end of the cartridge assembly. The jaw assembly has a longitudinal axis and includes a first jaw connected to a second jaw. The first jaw includes an anvil surface that is a smooth and flat without any staple-forming pockets. The second jaw has a top surface. The second jaw is movable relative to the first jaw such that the jaw assembly includes a closed position in which the anvil surface is adjacent to a top surface and a gap is defined between the top surface and the anvil surface. The second jaw includes a plurality of staple pockets. Each staple pocket has a longitudinal axis and an opening at the top surface. An actuator is coupled to the handle assembly. At least one camming surface is movable by the actuator within the second jaw and along a length of the second jaw. A plurality of staples is positioned inside the staple pockets. Each staple includes an open configuration for penetrating tissue and a closed configuration for retaining tissue. The plurality of staples is located inside the staple pockets in an open configuration. With the jaw assembly in a closed position, translation of the camming surface along the second jaw ejects the staples from the staple pockets toward the anvil surface of the first jaw to deform the staples from an open configuration against the anvil surface to a closed configuration.

**[0009]** According to another aspect of the invention, a surgical stapler is provided. The surgical stapler includes a handle assembly and a cartridge assembly removably connected to the handle assembly. The cartridge assembly

includes a proximal end and a distal end and a jaw assembly at the distal end. The jaw assembly has a longitudinal axis and includes a first jaw connected to a second jaw. The first jaw has an anvil surface and the second jaw has a top surface. The second jaw is movable relative to the first jaw such that the jaw assembly includes a closed position in which the anvil surface is adjacent to a top surface defining a gap between the top surface and the anvil surface. The second jaw includes a plurality of staple pockets having a plurality of openings at the top surface. The staple pockets are arranged in at least three substantially parallel rows along the top surface of the second jaw. The stapler includes an actuator coupled to the handle assembly and at least one camming surface movable by the actuator along a length of the second jaw. A blade is provided and configured to be movable within the gap defined between the top surface and the anvil surface when the first jaw and second jaw are in the closed position. The blade is configured to sever tissue located between the first jaw and the second jaw defining a cutting line. A plurality of staples is positioned inside the plurality of staple pockets. The camming surface is configured to eject staples from the staple pockets and against the anvil surface to deform the staples with translation of the camming surface along the second jaw. The second jaw includes a number of rows of staple pockets on one side of the blade that is different from a number of rows of staple pockets on the other side of the blade cutting line.

**[0010]** According to another aspect of the invention, a surgical stapler is provided. The surgical stapler includes a handle assembly removably connected to a cartridge assembly. The cartridge assembly includes a jaw assembly at the distal end. The jaw assembly has a longitudinal axis and includes a first jaw connected to a second jaw. The first jaw has a longitudinal axis and an anvil surface. The anvil surface includes a series of parallel channels. Each channel has a length and a surface that may be any shape, semi-cylindrical, curved, concave, square, or rectangle and configured for assisting in closing the staple in the desired direction. The lengths of the channels are perpendicular to the longitudinal axis of the jaw assembly. The second jaw has a top surface and is movable relative to the first jaw. The jaw assembly has a closed position in which the anvil surface is adjacent to a top surface and a gap is defined between the top surface and the anvil surface. The second jaw includes a plurality of staple pockets. Each staple pocket has an opening at the top surface. An actuator coupled to the handle assembly is provided. The stapler includes at least one camming surface movable by the actuator within the second jaw and along a length of the second jaw. A blade is provided and configured to be movable within the gap defined between the top surface and the anvil surface when the first jaw and second jaw are in the closed position. The blade is configured to sever tissue located between the first jaw and the second jaw defining a cutting line. A plurality of staples is positioned inside the staple pockets. Each staple includes an open configuration for penetrating tissue and a closed configuration for retaining tissue. The plurality of staples is located inside the staple pockets in an open configuration. The channels extend across the anvil surface on either side of the cutting line. With the jaw assembly in a closed position, translation of the camming surface along the second jaw ejects the staples from the staple pockets toward the anvil surface of the first jaw to deform the staples from an open configuration against the anvil surface to a closed configuration. The channels are configured to permit the formation of staples into a closed configuration.

[0011] According to another aspect of the invention, a surgical stapler is provided. The surgical stapler includes a handle assembly removably connected to a cartridge assembly. The cartridge assembly has a proximal end and a distal end and a jaw assembly located at the distal end. The jaw assembly has a longitudinal axis and includes a first jaw connected to a second jaw. The first jaw has a longitudinal axis and an anvil surface. The anvil surface includes a series of parallel channels. Each channel has a length and a surface that may be any shape, curved, concave, semi-cylindrical, square, or rectangle and configured for assisting in closing the staple in the desired direction. The length of each channel is parallel to the longitudinal axis of the jaw assembly and extends along the anvil surface. The second jaw has a top surface. The second jaw is movable relative to the first jaw. The jaw assembly includes a closed position in which the anvil surface is adjacent to a top surface and a gap is defined between the top surface and the anvil surface. The second jaw includes a plurality of staple pockets having a plurality of openings at the top surface. The staple pockets are arranged in parallel rows along the top surface of the second jaw. An actuator is included and coupled to the handle assembly. At least one camming surface is movable by the actuator within the second jaw and along a length of the second jaw. The surgical stapler further includes a plurality of staples positioned inside the staple pockets. Each staple includes an open configuration for penetrating tissue and a closed configuration for retaining tissue. The plurality of staples is located inside the staple pockets in an open configuration. With the jaw assembly in a closed position, translation of the camming surface along the second jaw ejects the staples from the staple pockets toward the anvil surface of the first jaw to deform the staples from an open configuration against the anvil surface to a closed configuration. The channels are configured to permit the formation of staples into a closed configuration.

[0012] According to another aspect of the invention, a surgical stapler is provided. The surgical stapler includes a handle assembly removably connected to a cartridge assembly. The cartridge assembly has a proximal end and a distal end and includes a jaw assembly at the distal end. The jaw assembly includes a first jaw connected to a second jaw. The first jaw has an anvil surface and the second jaw has a top surface. The first jaw is connected to the second jaw such that the second jaw is movable relative to the first jaw. The jaw assembly includes a closed position in which the anvil surface is adjacent to a top surface and a gap is defined between the top surface and the anvil surface. The second jaw includes a first surface and a second surface substantially parallel to each other and perpendicular to the top surface. The first surface includes a plurality of recesses formed into the first surface. Each recess has a recessed wall, a front sidewall, a rear sidewall and a bottom wall. The second jaw includes a plurality of staple pockets. Each staple pocket is defined by each recess including an opening to the top surface of the second jaw. The first surface includes a plurality of longitudinally extending grooves formed into the first surface. The surgical stapler further includes an actuator coupled to the handle assembly. A first camming surface is also provided. The first camming surface includes a plurality of projections sized and configured to fit within the longitudinally extending grooves of the first surface and translate therein. The first camming surface is movable by the actuator along a length of the second jaw. The surgical stapler includes a plurality of staples positioned in the plurality of staple pockets. Each staple has a staple width and is

positioned within and supported by a staple pocket. With translation of the first camming surface along the jaw assembly, the projections of the first camming surface pass through one or more staple pockets making contact with a portion of the staple width to urge the staple out of the opening and against the anvil surface.

#### BRIEF DESCRIPTION OF THE DRAWINGS

[0013] FIG. 1 is a perspective view of a surgical stapler according to the present invention.

[0014] FIG. 2 is a side view of a stapler cartridge assembly according to the present invention.

[0015] FIG. 3 is semi-transparent side view a proximal end of a stapler cartridge assembly according to the present invention.

[0016] FIG. 4 is side view of an actuator shaft and I-beam according to the present invention.

[0017] FIG. 5 is a perspective view of a distal end of an actuator shaft and I-beam according to the present invention.

[0018] FIG. 6 is a perspective view of an I-beam according to the present invention.

[0019] FIG. 7 is a side view of an I-beam according to the present invention.

[0020] FIG. 8 is an end view of an I-beam according to the present invention.

[0021] FIG. 9 is a perspective view of an end effector with jaws in an open position according to the present invention.

[0022] FIG. 10 is a bottom perspective view of an upper jaw according to the present invention.

[0023] FIG. 11 is an end view of an upper jaw according to the present invention.

[0024] FIG. 12 is a bottom perspective view of an upper jaw with curved channels according to the present invention.

[0025] FIG. 13 is an end view of an upper jaw with curved channels according to the present invention.

[0026] FIG. 14 is a top perspective view of a lower jaw according to the present invention.

[0027] FIG. 15 is a side view of a lower jaw according to the present invention.

[0028] FIG. 16 is a top rear perspective view of a lower jaw according to the present invention.

[0029] FIG. 17 is a top perspective view of a staple cartridge according to the present invention.

[0030] FIG. 18 is a top view of a staple cartridge according to the present invention.

[0031] FIG. 19 is an exploded top perspective view of a staple cartridge according to the present invention.

[0032] FIG. 20 is a side view of first plate of a staple cartridge according to the present invention.

[0033] FIG. 21 is a top perspective sectional view of a staple cartridge according to the present invention.

[0034] FIG. 22 is a top perspective sectional view of a staple cartridge, I-beam and slider according to the present invention.

[0035] FIG. 23 is a schematic of removed tissue resolved with an asymmetric staple cartridge according to the present invention.

[0036] FIG. 24 is a schematic of an asymmetric stapler grasping tissue according to the present invention.

[0037] FIG. 25 is a schematic of an asymmetric stapler with a curved end effector according to the present invention.

[0038] FIG. 26 is a top perspective view of a slider according to the present invention.

[0039] FIG. 27 is an end view of a slider according to the present invention.

[0040] FIG. 28 is a side elevational view of a slider according to the present invention.

[0041] FIG. 29 is a top view of a slider according to the present invention.

[0042] FIG. 30 is a top rear perspective view of a slider according to the present invention.

[0043] FIG. 31 is a top perspective view of a staple according to the present invention.

[0044] FIG. 32 is a side view of a staple according to the present invention.

[0045] FIG. 33 is an end view of a staple according to the present invention.

[0046] FIG. 34 is a top view of a staple according to the present invention.

[0047] FIG. 35 is a top perspective view of a staple in a closed configuration according to the present invention.

[0048] FIG. 36 is a side elevational view of a staple in a closed configuration according to the present invention.

[0049] FIG. 37 is an end view of a staple in a closed configuration according to the present invention.

[0050] FIG. 38 is a side view of a staple with barbs according to the present invention.

[0051] FIG. 39 is a side view of a staple with barbs according to the present invention.

[0052] FIG. 40 is a top perspective sectional view of a four-pronged staple in a staple pocket, and a slider according to the present invention.

[0053] FIG. 41 is a semi-transparent, top perspective, sectional view of a slider and a plurality of four-pronged staples loaded in a lower jaw and a slider according to the present invention.

[0054] FIG. 42A is a top perspective view of a four-pronged staple according to the present invention.

[0055] FIG. 42B is a side elevational view of a four-pronged staple according to the present invention.

[0056] FIG. 42C is a top view of a four-pronged staple according to the present invention.

[0057] FIG. 42D is an end view of a four-pronged staple according to the present invention.

[0058] FIG. 43A is a top perspective view of a four-pronged staple according to the present invention.

[0059] FIG. 43B is a top perspective view of a staple according to the present invention.

[0060] FIG. 44A is a top perspective view of a four-pronged staple according to the present invention.

[0061] FIG. 44B is a side elevational view of a four-pronged staple according to the present invention.

[0062] FIG. 44C is a top view of a four-pronged staple according to the present invention.

[0063] FIG. 44D is an end view of a four-pronged staple according to the present invention.

[0064] FIG. 45A is a top perspective view of a four-pronged staple according to the present invention.

[0065] FIG. 45B is a side elevational view of a four-pronged staple according to the present invention.

[0066] FIG. 45C is a top view of a four-pronged staple according to the present invention.

[0067] FIG. 45D is an end view of a four-pronged staple according to the present invention.

[0068] FIG. 46A is a top perspective view of a six-pronged staple according to the present invention.

[0069] FIG. 46B is a side elevational view of a six-pronged staple according to the present invention.

[0070] FIG. 46C is a top view of a six-pronged staple according to the present invention.

[0071] FIG. 46D is an end view of a six-pronged staple according to the present invention.

[0072] FIG. 47A is a side sectional view of a staple inside a staple pocket of a lower jaw and an upper jaw according to the present invention.

[0073] FIG. 47B is a side sectional view of a staple contacting the upper jaw according to present invention.

[0074] FIG. 47C is a side sectional view of a staple contacting the upper jaw and deforming according to the present invention.

[0075] FIG. 48 is a top view of a plurality of staples connected to a backbone according to the present invention.

[0076] FIG. 49 is a top perspective view of a staple cartridge inserted in a lower jaw according to the present invention.

[0077] FIG. 50 is a top perspective view of a staple cartridge inserted in a lower jaw according to the present invention.

[0078] FIG. 51 is a top perspective view of a staple cartridge being inserted into a lower jaw according to the present invention.

[0079] FIG. 52 is a top perspective view of a staple cartridge being inserted into a lower jaw according to the present invention.

[0080] FIG. 53 is a transparent sectional view of a handle assembly according to the present invention.

[0081] FIG. 54 is a rear top perspective view of an end effector with an upper jaw in an open position according to the present invention.

[0082] FIG. 55 is a rear top perspective view of an end effector with the upper jaw in a closed position according to the present invention.

[0083] FIG. 56 is a side elevational view of an end effector with an upper jaw in an open position according to the present invention.

[0084] FIG. 57 is a side elevational view of an end effector with an upper jaw in a closed position according to the present invention.

[0085] FIG. 58 is a rear, top perspective, sectional view of a surgical stapler according to the present invention.

[0086] FIG. 59 is a rear, semi-transparent, top perspective, sectional view of a handle assembly according to the present invention.

[0087] FIG. 60 is a side elevational, sectional view of a handle assembly according to the present invention.

[0088] FIG. 61 is a semi-transparent, side elevational, sectional view of an end effector according to the present invention.

[0089] FIG. 62 is a semi-transparent, side elevational, sectional view of an end effector according to the present invention.

[0090] FIG. 63 is a semi-transparent, top perspective, sectional view of an end effector according to the present invention.

[0091] FIG. 64 is a semi-transparent, side elevational, sectional view of a handle assembly according to the present invention.

[0092] FIG. 65 is a semi-transparent, top perspective, sectional view of a handle assembly according to the present invention.

[0093] FIG. 66 is a semi-transparent, side elevational view of an end effector with an upper jaw in an open position according to the present invention.

[0094] FIG. 67 is a semi-transparent end view of an end effector according to the present invention.

[0095] FIG. 68 is a top perspective, sectional view of a plate, slider and staple according to the present invention.

#### DETAILED DESCRIPTION

[0096] Referring to FIG. 1, there is shown a perspective view of a surgical stapler 10 according to the present invention. The stapler 10 is comprised of a handle assembly 12 removably connected to a stapler cartridge assembly 14. The handle assembly 12 is configured to control the instrument and actuate deployment of staples located in the distal end of the stapler cartridge assembly 14. After the staples have been expended from the stapler 10, the stapler cartridge assembly 14 is removed from the handle assembly 12 and a new stapler cartridge assembly 14 is connected to the handle assembly 12 for continued stapling.

[0097] Turning to FIG. 2, the stapler cartridge assembly 14 will now be discussed in detail. The stapler cartridge assembly 14 includes a connector 16 at the proximal end and an end effector 18 at the distal end. An outer tube 20 is connected to the end effector 18 at the distal end and to the connector 16 at the proximal end. An actuator shaft 22 is disposed inside the lumen of the outer tube 20. The outer tube 20 is substantially cylindrical having an outer diameter of approximately 5-10 mm. The actuator shaft 22 is configured to slide longitudinally relative to the outer tube 20. Detail of the proximal end of the stapler cartridge assembly 14 is shown in FIG. 3.

[0098] Turning to FIG. 3, the proximal end of the stapler cartridge assembly 14 is shown. The connector 16 includes a bolt 24 that extends laterally outwardly from the outer surface of the connector 16. A similar bolt 24 extends on the opposite side of the connector 16 and is not visible in FIG. 3. The bolt 24 is configured for a bayonet-like connection with the handle assembly 12 of the stapler 10 that includes a complementary slot for receiving the bolt 24 to secure the cartridge assembly 14 to the handle assembly 12. FIG. 3 also illustrates the actuator shaft 22 moved proximally relative to the outer tube 20 when compared to FIG. 2 in which the actuator shaft 22 is shown to be moved more distally relative to the outer tube 20. As seen in FIG. 3, the proximal end of the actuator shaft 22 includes a bolt 26 that extends laterally outwardly from the actuator shaft 22. The bolt 26 is configured for a bayonet-like connection with an actuator shaft of the handle assembly 12 which includes a complementary slot for receiving the bolt 26. Mating the bolt 24 of the connector 16 to handle assembly 12 simultaneously mates the bolt 26 of the actuator shaft 22 to the actuator shaft of the handle assembly 12. When connected to the handle assembly 12, the handle assembly 12 is used to move the actuator shaft 22 forward and backward inside the outer tube 20 to effect opening and closing of the distal jaw-like members and the deployment of staples.

[0099] Turning to FIG. 4, the actuator shaft 22 will now be described. The actuator shaft 22 is an elongated shaft having a substantially cylindrical proximal portion 28 having actuator bolts 26 at the proximal end for connection with the actuator of the handle assembly 12. The substantially cylindrical portion 28 is sized to fit closely inside lumen of the outer tube 20. The cylindrical portion 28 is connected with pins to an extended I-beam portion 30 toward the distal end of the actuator shaft 22. The distal end of the actuator shaft 22

includes an I-beam 32 connected to the extended I-beam portion 30. The I-beam 32 is connected to the extended I-beam portion 30 as shown in FIG. 5.

[0100] Turning now to FIGS. 6-8, the I-beam 32 will now be described. The I-beam 32 includes a top portion 34 and a bottom portion 36 interconnected by a middle portion 38. The top portion 34 includes a beveled front end 40 and a curved top. The middle portion 38 includes a blade 42 and an angled portion 44 at the front end. At the back end, the middle portion 38 includes an extension 46 for connecting with the extended I-beam portion 30 as shown in FIG. 5. The bottom portion 36 leads the front end of the I-beam 32 and includes a curved bottom. The front-elevational view of the I-beam is shown in FIG. 8 which illustrates the profile to be in the shape of a capital letter "I".

[0101] Turning now to FIG. 9, the end effector 18 will be described. The end effector 18 includes an upper jaw 48 hinged to a lower jaw 50. At least one staple cartridge 52 containing a plurality of staples 54 is disposed inside the lower jaw 50. The at least one staple cartridge 52 is configured to receive a plurality of staples 54 that are not visible in FIG. 9. The end effector 18 further includes a slider 56 configured to urge the staples 54 out of the cartridge 52. The slider 56 is not visible in FIG. 9.

[0102] Turning to FIGS. 10-11, the upper jaw 48 will now be described. The upper jaw 48 includes a flat anvil surface 58 or plate defining a central slot 60. The central slot 60 is elongated with an open proximal end. The central slot 60 is sized and configured to receive at least a portion of the middle portion 38 of the I-beam 32 such that the I-beam 32 slides relative to the upper jaw 48 inside and along the central slot 60. The outer surface of the upper jaw 48 is curved and substantially semicircular in shape to conform to a cylindrical lumen of a cannula in which it is inserted. The upper jaw 48 includes a top cover 62. The top cover 62 forms part of the outer circumference of the upper jaw 48 and together with the anvil surface 58 define therebetween a passageway 64 for receiving the top portion 34 of the I-beam 32 such that the top portion 34 slides relative to the upper jaw 48 inside the passageway 64. At the proximal end, the upper jaw 48 further includes flanges having apertures for receiving pins and connecting to the lower jaw 50.

[0103] A typical anvil of a conventional surgical stapler includes staple-forming pockets in the surface of the anvil that are designed to receive the legs of a staple and guide, angulate and bend the staple legs as the staple is urged against the anvil. These surface formations of a typical anvil aid in the deformation of the staple as it is deployed to achieve proper staple formation. Any misalignment between the staple-forming pockets and the staple leads to the staples missing the staple forming pockets, resulting in catastrophic failure of the staple line. The detailed staple-forming pockets introduce significant manufacturing difficulties and increase costs of production. Advantageously, the present invention does not utilize staple-forming pockets in the surface of the anvil. The anvil surface is smooth and/or flat. By redesigning the staple to not require anvil pockets to be formed, anvil pockets are eliminated completely simplifying the design while advantageously bringing an additional level of reliability to the stapler 10. Slight misalignment is no longer a concern especially with flat plate designs. The simplified design is also a major benefit for manufacturing as the anvil costs are reduced and the need for ultra-high precision parts to maintain perfect alignment are no longer needed. In one variation, the anvil

surface 58 is completely flat as shown in FIG. 10. In another variation shown in FIG. 12, the anvil surface includes a series of curved channels 66 having substantially smooth surfaces against which staples can deform into the proper configuration. The lengths of the channels 66 are perpendicular to the longitudinal axis of the upper jaw 48. The wave-like arrangement of channels 66 defines a central slot 60 in the anvil surface and reduces the need for critical alignment from side to side. Critical alignment of the staple is not required as the channels 66 are wide enough to easily receive the staple legs. The curvature of the channels 66 assists in deflecting the staple legs in the proper direction. In another variation, the anvil surface includes two or more longitudinal curved channels 68 that extend along the axis of the device as shown in FIG. 13. The elongate curved channels 66, 68 permit the formation of staples 54 without the worry and cost of proper alignment of each staple with each staple-forming pocket. Although the channels 66, 68 are shown to be curved, they can have square or rectangular cross-sections for assisting in closing the staple in the desired direction.

[10104] Referring now to FIGS. 14-16, the lower jaw 50 will be described. The lower jaw 50 is an elongate piece sized and configured to complementarily mate with the upper jaw 48. The lower jaw 50 has an open top and a curved outer surface. The cross-section of the lower jaw 50 is substantially semi-circular in shape except at the proximal end where it is substantially circular in cross-section. The depending flanges of the upper jaw 48 attach to the lower jaw 50 via pins inserted into apertures in the lower jaw 50 near the proximal end. When attached together, the upper jaw 48 and lower jaw 50 create a substantially cylindrical profile. The distal end of the lower jaw 50 is angled and the cylindrical proximal end defines a vertically oriented slot 70 visible in FIG. 16. This slot 70 is sized and configured to receive the extended I-beam portion 30 of the actuator shaft 22 with the I-beam itself 32 residing inside the lower jaw 50 distal of the slot 70. The cylindrical proximal end is adapted for attachment to the outer tube 20. The lower jaw 50 further includes a staple cartridge receiving portion 72. When one or more staple cartridges 52 are inserted into the staple cartridge receiving portion 72 of the lower jaw 50, a passageway is defined between the one or more staple cartridges 52 and a bottom cover 74. This passageway is sized and configured to receive the bottom portion 36 of the I-beam 32 such that the bottom portion 36 slides longitudinally with respect to lower jaw 50 inside the passageway. Inside the staple cartridge receiving portion 72, there is a ledge 76 at the distal end for securing the front end of one or more staple cartridges 52. A tongue 78 is formed at the proximal end for mating with a groove of the staple cartridge 52 to secure the proximal end of the staple cartridge 52 to the lower jaw 50. A cartridge retainer 80, shown in FIG. 9, covers the distal end tongues of staple cartridges 52 after being inserted into the lower jaw 50.

[10105] Referring now to FIGS. 17-22, the staple cartridge 52 will be described. The staple cartridge 52 comprises first plate 82, a second plate 84 and a third plate 86 connected together. The plates 82, 84, 86 are made from any polymer material, metal such as aluminum or stainless steel or glass filled nylon. The first plate 82 is elongate and substantially rectangular in shape and includes an outer surface 88 and an inner surface 90. The outer surface 88 is smooth and the inner surface 90 is formed with a plurality of staple holding locations 92. The staple holding locations 92 are recesses formed in the inner surface 90 of the first plate 82. Each staple holding

location 92 is substantially U-shaped and defined by a front sidewall 94 formed oppositely and substantially parallel to a rear sidewall 96. The rear sidewall 96 is interconnected to a bottom wall 98 forming an L-shaped continuous wall defining a gap 100 between the bottom wall 98 and the front sidewall 94. In one variation, no gap 100 is formed. Instead, the bottom wall 98 interconnects with both the front sidewall 94 and rear sidewall 96 to form a complete U-shaped staple holding location 92. The U-shaped staple holding locations are angled approximately 30-90 degrees with 90 degrees being a vertical non-angled orientation. The recessed wall 99 is recessed with respect to the inner surface 90. The first plate is approximately 0.020-0.025 inches thick and the depth of each recess or thickness of each sidewall 94, 96, 98 is approximately 0.005-0.008 inches. The staple holding locations 92 are configured for partially receiving and holding a complementary, substantially U-shaped staple that is thicker than the thickness of the sidewalls 94, 96, 98. The distal end of the first plate 82 includes a tongue 102 and the proximal end of the first plate 82 includes a groove 104 for connecting with the ledge 76 and tongue 78 of the lower jaw 50. The distal end and proximal end of the first plate 82 further include spacers 103, 105, respectively, that extend inwardly and are configured to space the inner surface 90 from the second plate 84. The first plate 82 is made of metal or plastic.

[10106] The second plate 84 or middle shim 84 is a thin elongate substantially rectangular shaped plate of metal or plastic having smooth outer surfaces. The second plate 84 is approximately 0.010-0.020 inches thick. The distal end includes a tongue 106 and the proximal end includes a groove 108 that are configured for connecting with the ledge 76 and tongue 78 of the lower jaw 50. In another variation, two second plates 84a, 84b are provided and each is approximately 0.005 inches in thickness. The first second plate 84a is sprung such that the first second plate exerts a force towards the first plate 82 and the other second plate 84b is also sprung such that it exerts a force towards the third plate 86.

[10107] The third plate 86 is substantially identical to and a mirror image of the first plate 82. The third plate 86 is elongate and substantially rectangular in shape and includes an outer surface 110 and an inner surface 112. The outer surface 110 is smooth and the inner surface 112 is formed with a plurality of staple holding locations 92 substantially identical to and a mirror image of the staple holding locations 92 of the first plate 82. The staple holding locations 92 are recesses formed in the inner surface 112 of the third plate 86. Each staple holding location 92 is substantially U-shaped and defined by two oppositely formed substantially parallel sidewalls, a front sidewall 94 and a rear sidewall 96. The rear sidewall 96 is interconnected to a bottom wall 98 forming an L-shape continuous wall defining a gap 100 between the bottom wall 98 and the front sidewall. In one variation, no gap 100 is formed. Instead, the bottom wall 98 interconnects with both the front sidewall 94 and rear sidewall 96 to form a complete U-shaped staple holding location 92. The recessed wall 99 is recessed with respect to the inner surface 112. The U-shaped staple holding locations are angled approximately 30-90 degrees with 90 degrees being a vertical non-angled orientation. The third plate is approximately 0.020-0.025 inches thick and the depth of each recess or thickness of each sidewall 94, 96, 98 is approximately 0.005-0.008 inches. The staple holding locations 92 are configured for partially receiving and holding a complementary, substantially U-shaped staple that is thicker than the thickness of the sidewalls 94, 96,

98. The distal end of the third plate 82 includes a tongue 114 and the proximal end of the third plate 86 includes a groove 116 for connecting with the ledge 76 and tongue 78 of the lower jaw 50. The distal end and proximal end of the third plate 82 further include spacers 115, 117, respectively, that extend inwardly and are configured to space the inner surface 112 of the third plate 86 from the second plate 84.

[0108] The first plate 82, second plate 84 and third plate 86 are connected or sandwiched together to form a staple cartridge 52 having two rows of staggered staple pockets 118 for placement on one side of the blade 42 of the I-beam 32. The staple pockets 118 are staggered to form a more complete closed line of staples. A second staple cartridge 52 is placed on the other side of the blade 42 of the I-beam 32 forming two rows of staple pockets 118 on the other side of the blade 42 for a total of four rows of staple pockets 118. The cartridges 52 can be modified with additional plates to create more than two rows of staples and can include three or four rows of staples on each side of the I-beam 32. The staple pockets 118 are defined by the recessed wall 99, the front sidewall 94, rear sidewall 96, bottom wall 98 and the outer surface of the second plate 84. Each pocket 118 includes an open top and a partially open bottom. In one variation, the bottom is closed. Because the spacers 103, 105 of the first plate 82 space the inner surface 90 of the first plate 82 from the second plate 84, a first slot 120 is formed between the first plate 82 and the second plate 84. The first slot 120 is configured for receiving a first angled camming surface of the slider 56 that will be described in greater detail herein below. The first slot 120 intersects with the first row of staple pockets 118. Because the spacers 115, 117 of the third plate 86 space the inner surface 112 of the third plate 86 from the second plate 84, a second slot 122 is formed between the third plate 86 and the second plate 84. The second slot 122 is configured for receiving a second angled camming surface of the slider 56 that will be described in greater detail herein below. The second slot 122 intersects with the second row of staple pockets 118. The same configuration appears on the staple cartridge disposed on the other side of the I-beam 32. The staple cartridge 52 is considered to be a single unit holding all the staples on either side of the I-beam 32 or alternatively, there are two staple cartridge units, one disposed on either side of the I-beam 32.

[0109] Turning now to FIG. 22, there is shown another variation of the staple cartridge 52 wherein the second plate 84 is not smooth but also includes a plurality of staple holding locations 124 similar to the staple holding locations 92 of the first and third plates 82, 86. In this variation, both opposite outer surfaces of the second plate 84 include recesses defined by a recessed wall 126 that is recessed from the outer surface, a front sidewall 128, a rear sidewall 130 and a bottom wall (not shown). The bottom wall may or may not include a gap. The staple holding locations 124 in a first outer surface of the second plate 84 are located opposite to the staple holding locations 92 of the first plate 82 which together define the staple pocket 118. Also, the staple holding locations 124 formed in a second outer surface of the second plate 84 are located opposite to the staple holding locations 92 of the third plate 86 which together define the staple pockets 118. The staple holding locations 124 have the same angle as their opposite staple holding locations 92 in the first and third plates 82, 86. Each pocket 118 defined by staple holding locations 92 and 124 are configured to receive substantially U-shaped staples 54 such that they are supported by the sidewalls yet include an unsupported portion of the staple 54

that resides in the first and second slots 120, 122. This unsupported portion of the staple 54 that resides in either the first or second slots 120, 122 is exposed for contact with the angled camming surface of the slider 56 as it passes through the slot and urges the staple 54 upwardly out of the pocket 118. In this variation in which the second plate 84 includes staple holding locations 124, the depth of the staple receiving portions 92, 124 are approximately 0.005 inches each and the width of each slot 120, 122 is approximately 0.005-0.006 inches with the total thickness of the staple 54 being approximately 0.015 inches with approximately 0.005 inches of the staple residing in the slot 120, 122, approximately 0.005 inches of the staple residing in and supported by the staple holding location 92 of the first plate 82 and approximately 0.005 inches of the staple residing in and supported by the staple holding location 124 of the third plate 86. FIG. 22 illustrates the standard arrangement in which two rows of staggered staple pockets 118 are located on either side of the slider I-beam 32 blade 42 for delivering a total of four lines of staggered staples 54. In another variation, the staple cartridge 52 is configured to include an additional fourth plate (not shown) sandwiched together for creating a third row of staples pockets 118 on either side of the blade 42 for a total of six rows of staggered staples 54. Any number of staple rows is within the scope of the present invention achieved by the adding additional plates.

[0110] Turning now to FIGS. 23-25, in one variation of the invention, an asymmetrical staple cartridge is provided. The asymmetrical staple cartridge utilizes a different number of rows of staple pockets on either side of the I-beam 32 blade 42. In one variation, the staple cartridge includes two or three rows of staple pockets on one side of the I-beam 32 blade 42 and only one row of staple pockets on the other side of the I-beam 32 blade 42 creating a total of three or four rows of staples with one row of staples delivered on one side of the cutting line. The staple cartridge may be a single unitary piece or be comprised of two cartridges, one having two or three rows of staple pockets for delivering two or three rows of staples placed on one side of the blade 42 and a second staple cartridge having only one row of staple pockets for delivering only one row of staples on the other side of the blade 42. The asymmetric stapler advantageously results in a smaller device with a decreased diameter of the end effector 18. Alternatively, the saved space in the end effector 18 can be utilized to advantageously provide additional structural support in a device of the same diameter. While two to three rows of staples on both sides of the blade 42 may be preferred for holding living tissue, a specimen to be removed may only require one row of staples on one side of the cutting line designed for short term holding onto tissue to be removed. The resulting smaller device diameter would be beneficial in certain procedures such as in the removal of an endoluminal polyp. In such a procedure, the endoluminal polyp removal stapler would have two or three rows of staples on one side of the blade for delivering two or three rows of staples into the colon side of the cutting line and one row of staples for delivering one row of staples into the polyp side of the cutting line. Through the use of different number of staple rows on either side of the cutting line, the staplers can be tailored to their specific surgical applications. The result is a dramatic reduction in instrument size, in particular, the diameter of the end effector 18, or alternatively an instrument with of same size but having increased instrument strength and reliability. FIG. 23 illustrates the resulting cut employing an asymmetri-

cal stapler according to the present invention. FIG. 23 shows three lines 132 of staggered staples delivered into the organ side 134 and one line of staples 136 delivered into the removed tissue 138. In order to provide to the surgeon user visual indication as to which side of the stapler 10 delivers fewer rows, the end effector 18 of the stapler 10 is color coded such that the side of the stapler 10 that has fewer rows of staples is colored a different color from the side of the stapler that has two or more rows of staples as shown in FIG. 24. For example, the side of the stapler with a single line of staples is colored red and the other side of the blade is colored green. Other markings on the stapler 10 are possible. In another variation shown in FIG. 25, the end effector 18 of the stapler is curved such that the surgeon knows to place the concave portion of the curvature against or on the side of the polyp 138, for example, and the convex side of the curved end effector against the colon side 134. The curved jaws assist the surgeon user in denoting proper orientation of the stapler with the concave side of the curvature having few rows of staples compared with the concave side of the blade which has a greater number of rows of staples. In another variation, the concave side of the stapler blade includes fewer rows of staples relative to the convex side of the stapler blade.

[0111] Turning now to FIGS. 26-30, the slider 56 will be described. The slider 56 includes a slider base 140 having a bottom surface 142 and a top surface 144. At least a portion of the bottom surface 142 toward the distal end is curved to conform to the curved bottom 74 of the lower jaw 50. At the proximal end of the slider 56, the bottom surface 142 includes a recessed portion 146 sized and configured to receive the bottom portion 36 of the I-beam 32. A slot 148 is formed in the slider base 140 that opens at the proximal end and extends toward the distal end of the slider base 140. The slot 148 is sized and configured to receive at least the lower middle portion 38 of the I-beam 32. In one variation, the front end of the slider 56 that leads distal translation includes a beveled or angled front surface to assist in urging staples from the device. Upstanding from the top surface 144 of the slider base 140 are at least two angled camming surfaces 150. FIGS. 26-30 depict a slider 56 that includes four upstanding angled camming surfaces 150a, 150b, 150c, 150d. An asymmetrical staple cartridge according to the present invention will have a slider 56 that corresponds to the number of staple rows on each side of the I-beam blade 42. Two angled camming surfaces 150a, 150b are separated by an I-beam receiving portion 152 from the two angled camming surfaces 150c, 150d. The I-beam receiving portion 152 is sized and configured to receive the middle portion 38 of the I-beam 32. Each camming surface 150 is approximately 0.005 inches thick and includes an angled distal end. The angle of the camming surface 150 corresponds to the angle of the staple holding locations 92 and 124 which ranges from approximately 30-90 degrees wherein 90 degrees is a vertical camming surface 150. The slider 56 is disposed inside the lower jaw 50 inside a lower passageway defined between the one or more staple cartridges 52 and the bottom cover 74. The slider 56 is retained in the lower jaw 50 between the one or more staple cartridges 52 and bottom cover 74 yet the slider 56 is free to translate longitudinally distally and proximally with respect to the lower jaw 50. The upwardly extending camming surfaces 150a and 150b extend upwardly through slots 120 and 122, respectively, of the staple cartridge 52 on one side of the blade 42 of the I-beam 32. The other two upwardly extending camming surfaces 150c and 150d extend upwardly through slots 120 and 122, respec-

tively, of the other side of the staple cartridge 52 or second staple cartridge 52 on the other side of the blade 42 of the I-beam 32. The slider camming surfaces 150 are configured to contact staples residing inside staple pockets 118 and sequentially urge them out towards the anvil surface 58 of the upper jaw 48 as the slider 56 translates along the end effector 18.

[0112] Turning now to FIGS. 31-34, a staple 54 according to the present invention will be described. The staple 54 is shown in its undeformed or open condition. The staple 54 includes a first leg 154 and a second leg 156 interconnected by a base 158. The first leg 154 intersects with the base 158 at approximately 90 degrees and defines a first intersection 160. The second leg 156 intersects with the base 158 at approximately 90 degrees and defines a second intersection 162. The first leg 154 is longer than the second leg 156. The staple 54 includes an inner surface 164 and an outer surface 166 interconnected by a first sidewall 168 and second sidewall 170. The inner surface 164 intersects with the outer surface 166 at a first point 172 at the first leg 154 and at a second point 174 at the second leg 156. The first point 172 and second point 174 are line intersections in FIG. 31 that are perpendicular to the length of the staple 54. In another variation, the line intersections are parallel to the length of the staple 54. In another variation, the first point 172 and/or the second point 174 are point intersections. In another variation, the first point 172 and/or second point 174 are planar surfaces or any other geometric shape that is suitable for puncturing and penetrating tissue through which the staple is delivered. The first leg 154 includes a first tip 176 at the free distal end of the first leg 154 and the second leg 156 includes a second tip 178 at the free distal end of the second leg 156. The first and second tips 176, 178 begin where the first and second legs 154, 156, respectively, begin to taper or decrease in cross-sectional area in the direction distally along the leg 154, 156.

[0113] With particular attention to FIGS. 32-34, the first leg 154 is approximately 0.097 inches long and the second leg 156 is approximately 0.050 inches long. The ratio of the shorter second leg 156 to the longer first leg 154 is approximately  $\frac{1}{2}$ . The overall length of the base 158 is approximately 0.080 inches and each leg 154, 156 is perpendicular to the base 158. The radius of curvature of the outer surface 166 at the first and second intersections 160, 162 is approximately 0.009 inches. The distance between the first sidewall 168 and the second sidewall 170 or thickness of the staple is approximately 0.015 inches. The distance between the inner surface 164 and the outer surface 166 or width of the first and second legs 154, 156 is approximately 0.010 inches. The distance between the inner surface 164 and the outer surface 166 or width of the base 158 is also approximately 0.010 inches. The first tip 176 includes a curved outer surface 166 having a radius of curvature of approximately 0.034 inches. This curve forms a concave outer surface 166 in the location of the first tip 176. The inner surface 164 at the first tip 176 is perpendicular to the base 158 and intersects with the curved outer surface 166 at a line intersection defining the first point 172. The second tip 178 includes an angled outer surface 166. The portion of the outer surface 166 in the location of the second tip 178 is angled approximately 10 degrees from vertical towards the inner surface 164. The portion of the inner surface 164 in the location of the second tip 178 is angled approximately 30 degrees from vertical towards the outer surface 166. Together the angled outer surface 166 and the angled inner surface 164 in the location of the second tip 178 form an

angle of approximately 40 degrees therebetween and define a line intersection at the second point 174.

[0114] With particular attention to FIGS. 35-37, the staple 54 is shown in its deformed or closed configuration in which the first leg 154 is angled towards the second leg 156 to form a triangular shape or delta or D-shaped configuration. The triangular shape results when the first leg 154 is deformed as a result of urging the undeformed staple 54 from staple pockets 118 in the lower jaw 50 against the anvil surface 58 of the upper jaw 48 of the stapler 10 of the present invention. In this delta configuration, the second leg 156 remains upstanding and substantially perpendicular to the base 158 and the first leg 154 is deflected to towards the second leg 156 until the first and second tips 176, 178 meet or are substantially in juxtaposition to each other. The resulting angle of the deflected first leg 154 with respect to the base 158 is approximately 29 degrees. In one variation, the staple has a circular cross-section. In another variation of the staple 54, a stress concentration is formed in the first leg 154 to create a weaker location in the first leg 154 so that deformation, bending or deflection of the first leg 154 takes place in the location of the stress concentration. An example of a stress concentration is at least one notch formed in the inner surface 164 at a location along the first leg 154 to encourage bending of the first leg 154 to occur at the stress concentration. An example of stress concentration in the form of a notch 188 is shown in FIGS. 44A and 44B. In another variation, stress concentrations such as one or more notches are strategically placed to effect a variety of closed staple shapes. For example, closed staple shapes are not limited to a triangular shaped staple but also include rectangular, square, rhombus, and trapezoid shapes. Furthermore, in another variation, notches are formed to capture one leg inside the notch formed in the opposite staple leg to create a locking variant in which the closed staple shape includes interlocked first and second legs configured resist forces that would open the staple from a closed and interlocked configuration.

[0115] Turning to FIGS. 38-39, the staple 54 is shown to include at least one barb 180. In the variation shown in FIG. 38, a single barb 180 is provided near the distal end of each leg 154, 156 formed in the inner surface 164 of the staple 54. Barbs assist in providing an increased mechanical hold of the staple into tissue and can be formed on either or both legs and on the inner surface 164 or outer surface 166. Multiple barbs 180 along one of the legs are shown in FIG. 39. In FIG. 39, four barbs 180 are formed in the inner surface of the first leg 154 and one barb 180 is formed in the inner surface of the second leg 156. Smaller barbs 180 such as micro and nano sized barbs are also within the scope of the present invention.

[0116] Turning now to FIGS. 40-41, there is shown a four-pronged staple 182. The four-pronged staple 182 includes a longer first leg 154a interconnected to a shorter second leg 156a by a base 158a and a second longer first leg 154b interconnected to a shorter second leg 156b by a base 158b. Each pair of staple legs 154a, 156a and 154b, 156b and their interconnected bases 158a, 158b are substantially identical to the staple 54 depicted and described with respect to FIGS. 31-37, except in the four-pronged staple 182 the two pairs of legs are interconnected by a enlarged base portion 184 that has the same thickness as staple bases 158a, 158b which are approximately 0.010 inches thick. The enlarged base portion 184 is connected to base 158a and base 158b and serves as a coming surface for engagement with a slider 56 that includes an enlarged angled slider coming surface 186. The staple

cartridge 52 is still formed in a similar manner as described with respect to FIGS. 17-22 except that it is adapted to receive a wider staple having wider slots 120, 122 to accommodate the wider four-pronged staple 182 and wider slider 56. The cartridge 52 adapted for the four-pronged staple 182 is preferably similar to that described with respect to FIG. 22 in which the first plate 82 and second plate 84 include oppositely formed angled staple holding locations 92, 124, respectively. At least a portion of the first leg 154a, second leg 156a and base 158a is disposed in the staple holding location 92 of the first plate 82 and at least a portion of the first leg 154b, second leg 156b and base 158b is disposed in the staple holding location 124 of the second plate 84. An additional third plate 86 may hold another row of four-pronged staples 182 between the third plate 86 and second plate 84 as described above with another slider coming surface 186 residing in the second slot 122. The four-pronged staples 182 are angled to match the angle of the slider 56 coming surface 186 such that when the slider 56 is pushed forward by the translating I-beam 32, the angled slider coming surface 186 contacts the enlarged base portion 184 of the staple 182 to urge the staple 182 upwardly and out of the cartridge 52 and against the anvil surface 58 of the upper jaw 48 where the staple 182 is deformed into tissue. The deformed staple includes two triangular shaped closures wherein the first legs 154a, 154b are bent towards the second legs 156a, 156b, respectively.

[0117] FIGS. 42A-42D illustrate various views of a four-pronged staple 182 that includes an even larger base portion 184 to provide additional strength to the staple 182. The first and second tips 176a, 176b, 178a, 178b include angled first and second sidewalls 168a, 168b, 170a, 170b to form line intersections that are parallel to the length of the staple 182. A four-pronged staple 182 having flat, blunt first tips 176a, 176b and second tips 178a, 178b are shown in FIG. 43A. The four-pronged staple 182 of FIG. 43A may be cut along dotted lines to form two single staples 54 having only two legs 154, 156 each with flat first and second tips 176, 178 as shown in FIG. 43B.

[0118] Turning now to FIGS. 44A-44D, there is shown a four-pronged staple 182 having notches 188 formed in the inner surface of first legs 154a, 154b. The notches 188 are curved semi-cylindrically shaped indentations that create stress concentrations in the legs 154a, 154b such that while being deformed the legs 154a, 154b will tend to bend in the location of the notches 188. In the variation of the four-pronged staple 182 of FIGS. 44A-44D, the first tips 176a, 176b include curved outer surfaces 166a, 166b intersecting with straight inner surfaces 164a, 164b to form line intersections that are perpendicular to the length of the staple 182. The second tips 178a, 178b are formed by angled outer surfaces 166a, 166b intersecting with straight inner surfaces 164a, 164b to form line intersections that are perpendicular to the length of the staple 182. When deformed, the first legs 154a, 154b are bent at the notches 188 such that first tips 176a, 176b contact second tips 178a, 178b to form two connected triangular shaped closures.

[0119] With reference to FIGS. 45A-45D, a four-pronged staple 190 having staggered legs is shown. A first two-pronged staple having a longer first leg 154a interconnected to a shorter second leg 156a by a base 158a is connected via an angled enlarged planar base portion 184 to a second two-pronged staple having a longer first leg 154b interconnected to a shorter second leg 156b by a base 158b such that the first two-pronged staple is offset or staggered with respect to the

second two-pronged staple. The first and second two pronged staples are substantially identical to the staple described above with respect to FIGS. 31-37. The angled base portion 184 interconnecting the two two-pronged staples allows the first two-pronged staple to be offset from the second two-pronged staple resulting in a four-pronged staple 190 with staggered legs 154a, 154b, 156a, 156b. The enlarged base portion 184 serves as a camming surface for camming against the angled camming surface 150 of the slider 56. When actuated the two longer first legs 154a, 154b are deformed against the anvil surface 58 towards the second legs 156a, 156b, respectively, to form two triangular shaped closures capturing tissue therebetween. When an entire row of four-pronged staples 190 are deployed, the result is two effective rows of staggered staples.

[0120] Turning now to FIGS. 46A-46D, there is shown a six-pronged staple 192. The six-pronged staple 192 includes a first two-pronged staple 194 connected to a second two-pronged staple 196 connected to a third two-pronged staple 198 in a staggered fashion. The first, second and third two-pronged staples 194, 196, 198 are substantially identical to the two pronged staple 54 of FIGS. 31-37 described above. The first two-pronged staple 194 includes a longer first leg 154a interconnected to a shorter second leg 156a by a base 158a. The second two-pronged staple 196 includes a longer first leg 154b interconnected to a shorter second leg 156b by a base 158b. The third two-pronged staple 196 includes a longer first leg 154c interconnected to a shorter second leg 156c by a base 158c. Each of the two-pronged staples 194, 196, 198 is connected to each other at their bases 158a, 158b, 158c, respectively. The first two-pronged staple 194 is connected to the second two-pronged staple 196 by an angled extended base portion therebetween such that the first two-pronged staple 194 is offset from the second two-pronged staple 196. The second two-pronged staple 196 is connected to the third two-pronged staple 198 by an angled extended base portion therebetween such that the second two-pronged staple 196 is offset from the third two-pronged staple 198. The three two-pronged staples 194, 196, 198 are connected such that the first and third two-pronged staples 194, 198 are in alignment with respect to each other and the middle second two-pronged staple 196 is offset relative to the first and third two-pronged staples 194, 198. The six-pronged staple 192 is loaded in an angled manner into a cartridge as described above with respect to FIGS. 22, and 40-41 wherein the first two-pronged staple 194 is disposed at least in part into a staple holding location 92 of the first plate 82 and the third two-pronged staple 198 is disposed at least in part into a staple holding location 124 of the second plate 84 such that the middle or second two-pronged staple 196 resides inside the first slot 120 together with a slider 56 having an enlarged camming surface 186 of the like described with respect to FIGS. 40-41 against which the base portions engage for deployment. Of course a third-plate 86 with staple holding locations 92 is loaded with staples 192 in the same manner for engagement with a second slider 56 residing inside the second slot 122. After the six-pronged staple 192 is urged by the slider against the anvil surface 58, the first legs 154a, 154b, 154c are deflected towards the second legs 156a, 156b, 156c, respectively, to form three triangular shaped closures that capture tissue. These three triangular shaped closures are staggered with respect to each other yet interconnected to form a wide and strong stapling of tissue.

[0121] Referring now to FIGS. 47A-47C, another staple variation is shown. In this variation, the staple 204 includes a first leg 154 interconnected to a second leg 156 by a base 158. The first leg 154 is substantially straight when undeformed and includes a first tip 176 having an angled or chamfered outer surface. The second leg 156 is slightly longer than the first leg 154. The second leg 156 also includes an elbow 206 at which the second leg 156 is bent slightly towards the first leg 154 while in the undeformed condition as shown in FIGS. 47A-47B. The second leg 156 includes a second tip 178 which in one variation commences to taper from the elbow 206. Since the staple 204 is disposed inside a cartridge at an angle as described above, when the staple 204 is urged upwardly by an advancing slider (not shown), both the first and second tips 176 and 178 contact the flat anvil surface 58 substantially simultaneously as shown in FIG. 47B. Continued urging of the staple 204 into the anvil surface 58 results in the first leg 154 bending towards the second leg 156 and the second leg 156 bending towards the first leg 154 as shown in FIG. 47C. The angled or chamfered outer surface at the first tip 176 assists in directing the first leg 154 towards the second leg 156. The elbow 206 and angled second leg 156 assist in directing the second leg 156 towards the first leg 154. Because the staple pockets 118 retain the staples 204 at an angle to the flat anvil surface 58, the second leg 156 has to be slightly longer and angled such that the portion of the second leg 156 that is distal to the elbow 206 is substantially perpendicular to the flat anvil surface 58 when the second tip 178 contacts the flat anvil surface 58. This variation advantageously does not require anvil pockets formed in the anvil surface and precise alignment of the staple legs 154, 156 with anvil pockets to effect deflection of staple legs 154, 156 towards each other. Such deflection is accomplished against a flat anvil surface 58.

[0122] With reference to FIG. 48, there is shown a plurality of staples 54 connected to a backbone 200 illustrating the formation of staples 54 in a fishbone style for ease of manufacturing, assembly and handling. A sheet of metal such as surgical steel, stainless steel, or titanium is provided and a plurality of staples 54 is cut into the sheet of metal on a wire electrical discharge machining (EDM) machine. The staples 54 may also be formed utilizing a micro-water jet, photo etching or by stamping. The staples 54 remain connected to the backbone 200 via narrow connecting tabs 202 until the staples 54 are broken off at the tabs 202 and then loaded into a staple cartridge. After a staple 54 is broken off a portion of the connecting tab 202 remains attached to the staple 54. The remnant tab 202 serves as a barb 180 for increasing mechanical holding onto tissue captured inside a closed staple 54 after deployment. Therefore, the staple 54 is manufactured without the need for post-processing such as bending and sharpening. Also, the backbone 200 can be an aid in the storage of staples 54 and in the assembly of staple cartridges.

[0123] Turning to FIGS. 49-50, a staple cartridge 52 in the form of a single unit is inserted into the staple cartridge receiving portion 72 of the lower jaw 50. The staple cartridge 52 may also be in the form of two units 52a, 52b with each unit having two slots 120, 122 with two rows of staples 54 residing inside staple pockets 118. An asymmetrical cartridge as described above can also be employed. The staple cartridge 52 is inserted such that the grooves 104, 108, 116 of first, second and third plates 82, 84, 86, respectively, engage the tongue 78 at the proximal end of the lower jaw 50 and the tongues 102, 106, 114 of the first, second and third plates 82,

**84, 86**, respectively, engage the ledge **76** at the distal end of the lower jaw **50**. A cartridge retainer **80** is connected covering the tongues **102, 106, 114** as shown in FIG. **50** to secure the cartridge in position. Each cartridge **52** can include a cover slip of paper (not shown) covering the staple pockets **118** to retain the staples **54** inside the pockets **118** during storage and handling. The cover slip is then removed by peeling away just prior to or after installation of the cartridge **52**. Each cartridge **52** also contains a slider **56** disposed inside the cartridge **52** such that the angled camming surfaces **150a, 150b** of the slider **56** reside in slots **120, 122**, respectively on one side of the I-beam receiving portion **152** and the angled camming surfaces **150c, 150d** of the slider **56** reside in slots **120, 122**, respectively on the other side of the I-beam receiving portion **152**. One side of the cartridge **52a** is spaced apart from the other side of the cartridge **52b** to create a central passageway **208** to allow passage of the translating I-beam **32**.

[0124] Another variation of cartridge **52** installation is shown in FIGS. **51-52**. In this variation, the front or distal end of the lower jaw **50** is open and the cartridge **52** includes rails **212** that engage tracks **210** formed in the staple cartridge receiving portion **72** of the lower jaw **50**. The cartridge **52** slides in through the open distal end of the lower jaw **50** which is then closed with a cap or latch (not shown). The cartridge **52** is shown to include a top plate **214** which increases the strength across the width of the device. After the staples **54** are expended, the staple cartridge **52** can be removed and disposed and a new cartridge inserted for continued stapling. In another variation, the staple cartridge **52** is pre-installed inside the stapler cartridge assembly **14** and after the staples **54** are expended the entire stapler cartridge assembly **14** is removed and disposed and a new stapler cartridge assembly **14** is connected to the handle assembly **12** for continue stapling.

[0125] With the stapler cartridge assembly **14** connected to the handle assembly **12**, the actuator shaft **22** connects to the actuator shaft **216** inside the handle assembly **12**. The handle assembly **12** is then used to operate the stapler **10** in three different functions or modes of operation. The first mode allows the user to open and close the jaws **48, 50** of the end effector **18**. The second mode fires the staples and the third mode of operation returns the I-beam **32** to its original proximal position following the firing of staples.

[0126] With reference to FIG. **53**, the handle **218** is connected to a forward driver **220** which engages a forward tooth on the actuator shaft **216**. When the handle **218** is depressed, the actuator **216** is moved slightly forward which in turn moves the actuator shaft **22** of the stapler cartridge assembly **14** forward. Since the actuator shaft **22** is connected to the I-beam **32**, the I-beam **32** advances forward with the depression of the handle **218**. As the I-beam **32** advances, the beveled front end **40** of the top portion **34** of the I-beam **32** enters the passageway **64** in the upper jaw **48** which deflects the open and spring biased upper jaw **48** downward from an open position to a closed position as shown in FIGS. **54-55**. The upper jaw **48** is connected to the lower jaw **50** with a pin such that the upper jaw **48** pivots with respect to the lower jaw **50**. Springs (not shown) are included to create a spring bias that urges the upper jaw **48** in an open position with respect to the lower jaw **50**. The top portion **34** of the I-beam **32** is shown entering the passageway **64** in FIG. **54** with the jaws biased in an open position. In FIG. **55**, the top portion **34** of the I-beam **32** has entered the passageway **64** and moved the upper jaw **48**

into a closed orientation with respect to the lower jaw **50**. When the handle **218** is released the actuator shafts **216, 22** move proximally pulling the I-beam **32** also proximally allowing the spring bias to open the jaws as the top portion **34** exits the passageway **64**. The user can open and close the jaws of the end effector **18** by pressing and releasing the handle **218** to position the targeted tissue between the upper and lower jaws of stapler **10**. The end effector **18** is shown in an open position in FIG. **56** and in a closed position in FIG. **57** in which the distance across the gap between the upper jaw **48** and lower jaw **50** is approximately 0.040 inches when in the closed position.

[0127] After the jaws are closed in position at the targeted tissue location, the stapler **10** is switched to operate in fire mode by depressing a fire button **224** on the handle assembly **12** as shown in FIG. **58**. The fire button **224** disengages an open driver **226** from the actuator shaft **216** as shown in FIGS. **59-60** freeing it for longitudinal movement. The open driver **226** is shown engaged with the teeth of the actuator shaft **216** in FIG. **60**. In FIG. **59**, the open driver **226** is shown disengaged from the teeth of the actuator shaft **216** with the fire button **224** depressed. With the open driver **226** disengaged, the trigger handle **218** swings out and the forward driver **220** engages with forward teeth on the actuator **216**. Depressing the handle **218** advances the actuator shaft **216** forward as the forward driver **220** freely engages teeth with each squeeze of the trigger handle **218**. The handle **218** is squeezed multiple times to advance the I-beam **32** all the way to the distal end of the cartridge **52**. The handle assembly **14** may also include a rotatable rack described in co-pending U.S. Provisional Patent Application entitled "Surgical stapler having actuation mechanism with rotatable shaft" incorporated herein by reference in its entirety.

[0128] Turning now to FIG. **61**, there is shown the end effector **18** with the jaws **48, 50** in a closed position. As the I-beam **32** is advanced distally, the top portion **34** of the I-beam **32** travels in the upper passageway **64** and the bottom portion **36** of the I-beam **32** enters the slot **148** of the slider **56** engaging with the slider **56** and pushing it distally. As the angled camming surface **150** leads, it contacts staples (not shown) to urge them out of staple holding locations **92**. The blade **42** of the I-beam **32** resides in the gap **228** between the upper jaw **48** and the lower jaw **50** cutting tissue captured between the jaws in between tissue resolved with two or more rows of staples on either side of the blade **42**.

[0129] FIGS. **62-63** illustrate the deployment of staples **54** as the slider **56** and I-beam **32** advance in the distal direction. The staples **54** are disposed inside staple pockets **118** such that at least a portion of the staple **54** rests against U-shaped staple holding locations **92** such that the longer first leg **154** is located proximally relative to the shorter second leg **156**. As the slider **56** advances, the angled camming surfaces **150** sequentially contact the staples. In one variation, a beveled front end **230** of the slider **56** contacts that portion of the outer surface **166** of the staple **54** such as the base **158** of the staple **54** that is in the gap **100** in the bottom wall **98** of the U-shaped staple holding location **92** and urges the staple **54** upwardly. As the slider **56** advances the angled camming surfaces **150** of the slider **56** contact the staples **54** and continue to urge them sequentially upwardly with distal translation of the slider **56**. With sufficient deployment height, the longer first leg **154** of the staple **54** contacts the flat anvil surface **58** of the upper jaw **48**. In particular, the first tip **176** contacts the flat anvil surface **58**. Because the first tip **176** includes a curved, chamfered or

beveled outer surface 166, contact of this curved outer surface with the flat anvil surface 58 assists in bending the first leg 154 towards the second leg 156. The curved outer surface 166 of the first tip 176 slides against the flat anvil surface 58 as the first leg 154 bends into a closed triangular configuration. The shorter second leg 156 is not bent or deformed. Unlike a conventional staple, which is fired with the staple legs perpendicular to the forming anvil, the staple of the present invention is fired at an angle with respect to a flat anvil surface 58. There are no staple forming pockets in the anvil surface of the present invention. As the long leg 154 contacts the flat anvil surface 58, the tip 176 of the long leg 154 slides freely along the anvil surface while the staple 54 is progressively pushed normal to the staple base 158 because the staple is at the same angle as the angled camming surface 150 of the slider 56 until the tip 176 of the long leg 154 meets the tip of the shorter second leg 156 and the staple is closed capturing tissue inside the triangular shaped closure. The closure force of the staple 54 of the present invention is advantageously relatively low when compared to conventional staples because only one leg is being deformed, the longer first leg 154; whereas, in conventional staplers, both legs of a staple are deformed simultaneously. Furthermore, closure forces are further reduced by the fact that the long leg is simply being bent over as opposed to being forced to buckle against an anvil pocket. Buckling forces of a beam are much greater than bending forces and conventional staples require the buckling of two staple legs simultaneously. Conventional stapling devices require high firing forces to apply the staple lines. The staple legs are forced perpendicular to the anvil pockets forcing them to buckle. These high forces apply significant stresses to the device components and can cause fatigue for the user. Therefore, the present stapler 10 greatly reduces forces required to deploy and deform staples. The staple forming forces of the present invention are relatively low when compared with conventional staple designs. Since only a single leg bends over in contact with the anvil surface, the user and device is benefited through reduced stresses on the components and reduced actuation forces for the user.

[0130] The staple deployment method of the present invention drives a slanted slider down the jaws of the stapling device. The slider 56 comes in direct contact with the staples 54 as it passes through the same space as the staples being deployed. The staples are partially held in place by pockets 118 in the interior jaws or cartridge 52 of the device. These pockets provide guidance for the staples as they are pushed out of the device and formed into tissue. The staples are held in the cartridge in such a way that only part of the staple thickness is resting in a pocket while the other part is in an open channel that is coplanar with the slider 56. One side of the staple is held against the first plate inside staple receiving locations 92 while the other side of the staple is held against the smooth wall of the second plate or, alternatively, in staple holding locations 124 also formed in the second plate. Each slider camming surface 150 travels down the center of the staple in each slot 120, 122. As the slider 56 is pushed distally along the length of the jaw, the angled slider ramp drives the staples out of the guided cartridge pockets. The angled camming surface 150 of the slider pushes normal to the staple base 158. The slider only contacts a part of the staple, while the remaining part of the staple is held against the staple holding locations 92 which serve as guides directing the staple out of the cartridge.

[0131] Turning now to FIGS. 64-65, after the staples are fired, the handle assembly 12 is switched into the third mode of operation in which the I-beam 32 is returned proximally to its starting position. A gear switch button 232 is depressed which rotates the actuator shaft 216 90 degrees so that the reverse teeth on the actuator 216 come into contact with the reverse driver 234. The reverse driver 234 is connected to the handle 218 by a series of gears. When the handle 218 is squeezed, the reverse driver 234 pulls the actuator 216 and I-beam 32 back. The trigger handle 218 is squeezed multiple times to return the I-beam 32 to its original position. The I-beam 32 is returned to its original proximal position to open the jaws 48, 50. With the I-beam 32 returned, the slider 56 is left in its distal fired position. FIG. 66 illustrates, the I-beam 32 returned and fully retracted resulting in the spring biased upper jaw 48 becoming open while the slider 56 is left in its distal location allowing the stapled tissue to be released from the jaws. When the actuator 216 and I-beam 32 is returned, the stapler cartridge assembly 14 can be detached from the handle assembly 12 and new stapler cartridge assembly 14 can be attached to continue stapling.

[0132] The conventional laparoscopic stapler is currently approximately 12 millimeters in diameter which requires a larger sized cannula for insertion and, hence, a larger incision in the patient. The laparoscopic stapler 10 of the present invention has a diameter of approximately 0.271 inches as shown in FIG. 67 which will advantageously fit inside smaller diameter cannulas that require smaller incisions in the patient. The smaller incision results in less pain, faster patient recovery times and a smaller scar visible after the operation. FIG. 67 illustrates that the I-beam 32 substantially defines the diameter of the end effector 18. Approximately a little less than half the diameter of the device is consumed with the upper jaw and gap between the upper and lower jaw leaving approximately half the diameter of the device, approximately 0.130 inches for housing the staples and mechanisms for staple deployment including the slider.

[0133] The problem presented in traditional staplers is that they require larger diameters and larger incisions as well as higher firing forces in order to deploy staples. This is due to the fact that traditional staples require a pusher to deploy staples. The pusher is an intermediate camming surface disposed between each staple and the slider. Typically, each pusher is of equal height as the staple and resides directly below the staple. The height of the pusher has to be approximately equal to the height of the staple in order to fully urge the staple out of the staple pockets and into the gap between the upper and lower jaws. The pusher typically includes an angled lower surface that cams against an angled slider. The upper surface of the pusher is typically flat and horizontal and cams normal to the base of the staple. In essence, the pusher takes up valuable space when trying to achieve a smaller stapler that will fit in a smaller sized cannula which is typically called a 5 millimeter cannula. The present invention successfully eliminates the pusher altogether due to the angled positioning of the staple such that the base of the staple is parallel to the angled camming surface of the slider. Because the staple of the present invention is placed at an angle, the horizontally traveling slider comes in direct contact with the staple during deployment without having any additional pusher between the staple and slider. Because there is no pusher required in the present invention, a great deal of space is saved resulting in a much smaller diameter device.

[0134] It is not just a matter of reducing staple size but also effectively deploying staples that form a closed staple configuration capable of holding tissue in a manner that is just as strong as a conventional stapler and doing so in a reliable and repeatable manner that is an important factor achieved by the stapler of the present invention. Another problem of conventional staplers that the present invention addresses and successfully avoids pertains to the anvil surface. Traditional anvil surfaces include detailed anvil pockets formed in the anvil surface. These anvil surface formations are necessary in order to reliably and repeatedly form staples in conventional staplers. The anvil surface is especially important as traditional staples are placed normal to the anvil surface and without anvil surface formations to guide the buckling staple legs the staple legs would splay in any direction and not form a nice closure important for securing tissue. Furthermore, the anvil pockets of traditional staplers require that the anvil of the upper jaw be perfectly aligned with the staple pockets and in particular, the staples residing in the pockets in order to effect perfect staple formation. Anvil surface formations or pockets are a necessity for staple formation reliability; however, they also increase manufacturing costs that result from not only forming detailed surface formation but also in making sure the anvil surface formations are in alignment with the staple trajectory. The present invention advantageously eliminates anvil surface formations and provides a smooth, flat anvil surface against which the staple legs are deformed. Typically, without anvil surface formations the staple legs would splay in any direction and not form a perfect closure. However, the present invention provides for angled staple holding locations that hold the staple at an angle with respect to the anvil surface. Furthermore, the staple has one longer leg and a shorter leg. As a result of this design, as the staple is ejected from the lower jaw, it is the longer leg that leads staple ejection. Because the longer leg leads, this leg will be the first leg to contact the anvil surface and instead of splaying in any direction the first leg is reliably bent towards the second leg. Misalignment of staple tips is eliminated because as the longer leg is being deformed against the flat anvil surface the remaining portion of the staple including the shorter leg remains substantially contained and guided in the staple pocket or staple holding location and prevented from lateral displacement that would result in a malformed staple. Also, the tip of the longer leg is curved or chamfered which provides a predilection for the staple to bend towards the second leg. Also, the curved tip allows the tip of the longer leg to slide against the smooth anvil surface as the longer leg of the staple is being deformed. Hence, the present invention not only reduces the overall diameter of the end effector, it also does so without sacrificing staple formation repeatability and reliability.

[0135] The problem of fitting a surgical stapler into a 5 mm cannula is solved by the absence of intermediate camming portions that are also known as “pushers” located between the slider and the staple. Typically, the legs of a staple are located in receiving pockets such that they are perpendicular to the anvil. The angled slider contacts the pushers which then contact the staple to drive it out of the staple pocket. Without an intermediate camming portion or pusher, the slider would have to contact the staple directly risking angular forces upon the staple that would angulate the staple legs out of alignment with the anvil surface formations resulting in malformed staples or angulate the staple legs with respect to the pocket resulting in the staple jamming against the pocket. Typically,

the staples are stacked above the pushers. Therefore, removal of pushers saves tremendous space in the design and angled staples contact an angled slider directly. The elimination of pushers also further reduces manufacturing costs as the number of components is reduced and eases manufacturing as pushers are no longer required to be assembled. The angled orientation of the staples themselves is also a tremendous space saver as opposed to the staples being vertically oriented as in traditional staplers. Since there is no target pocket or anvil surface formation for the staple legs to come into contact with, the reliability of staple formation is greatly improved as the staple is free to deform against a smooth anvil surface without risking misalignment with anvil pockets as in traditional staplers. Valuable space is also saved by the slider moving through the same space or slots in which the staples reside.

[0136] Turning now to FIG. 68, there is shown another variation of a staple cartridge 52 similar to that described above with respect to FIGS. 17-21 wherein like numbers are used to describe like parts. As described above, the cartridge 52 comprises at least two plates sandwiched together to form a single row of staple receiving pockets with additional plates added to increase the desired number of staple rows. The outer surface 88 of the first plate 82 is smooth and the inner surface 90 is formed with a plurality of staple holding locations 92. The staple holding locations 92 are recesses formed in the inner surface 90 of the first plate 82. Each staple holding location 92 is substantially U-shaped and defined by a front sidewall 94 formed oppositely and substantially parallel to a rear sidewall 96. The rear sidewall 96 is interconnected to a bottom wall 98 forming an L-shaped wall defining a gap 100 between the bottom wall 98 and the front sidewall 94. In one variation, no gap 100 is formed. Instead, the bottom wall 98 interconnects with both the front sidewall 94 and rear sidewall 96 to form a complete U-shaped staple holding location 92. The U-shaped staple holding locations are angled approximately 30-90 degrees with 90 degrees being a vertical non-angled orientation. FIG. 68 illustrates the U-shaped staple holding location being at 90 degrees or substantially perpendicular. The recessed wall 99 is recessed with respect to the inner surface 90. Segments of the inner surface 90 that are located between the staple holding locations 92 include a plurality of horizontal grooves 236 that extend between the staple receiving locations 92. The grooves 236 are rectangular and have square or rectangular cross-sections. The grooves 236 have a depth equal to the depth of the recessed wall 99. The grooves 236 are separated by lands 238 that constitute the inner surface 90 and therefore are equal in height to the inner surface 90. The grooves 236 stretch across the entire length of the first plate intersecting each sidewall 94, 96 and bottom wall 98 of the staple holding locations 92. The staple holding locations 92 are configured for partially receiving and holding a complementary, substantially U-shaped staple that is thicker than the thickness of the grooved sidewalls 94, 96, 98. In one variation, the staple holding locations 92 receive the entire thickness of a complementarily U-shaped staple as shown in FIG. 68 such that no portion of the staple 54 resides outside the staple holding location 92. The slider 56 includes an angled camming surface 150 with a side surface that is also formed with a plurality of horizontal grooves 240 forming channels for receiving the upstanding lands 238 that are located between staple holding locations 92. A second plate 84 or shim is not shown in FIG. 68 but together with the first plate 84 define a slot 120 therebetween inside which the

angled coming surface **150** of the slider **56** is capable of translating interconnected on the side surface with interlocked grooves **240** and lands **238**. Because a staple **54** is resident in a grooved staple receiving portion **92**, the angled coming surface **150** of the slider **56** is still able to contact the outer surface **166** of the staple **54** as the angled coming surface **150** translates through the grooves **236** to urge staple **54** upwardly and out. The grooved inner surface **90** of the first plate **82** advantageously allows the use of very thin staples; for example, staples that are the same depth as the staple pocket depth or depth of the staple holding location **92**. The depth of the staple pocket is approximately 0.0085 inches which is also the thickness of the staple **54** that can be used in this variation of the invention. Therefore, the grooved plate **82** not only allows for extremely thin staples, it further reduces the size of the staple or allows additional space for structures that make the end effector stronger.

**[0137]** The stapler of the present invention is particularly suited for laparoscopic procedures; however, the invention is not so limited and the stapler of the present invention can be used in open surgical procedures equally effectively. In laparoscopic procedures, the stapler of the present invention can be used, for example, for the closure and anastomosis of tissue such as colon, small intestines, and stomach.

**[0138]** It is understood that various modifications may be made to the embodiments of the surgical stapler disclosed herein. Therefore, the above description should not be construed as limiting, but merely as exemplifications of preferred embodiments. Those skilled in the art will envision other modifications within the scope and spirit of the present disclosure.

We claim:

1. A surgical stapler comprising:

a handle assembly;

a cartridge assembly connected to the handle assembly; the cartridge assembly having a proximal end and a distal end; the cartridge assembly comprising:

a jaw assembly at the distal end of the cartridge assembly; the jaw assembly comprising:

a first jaw having an anvil surface; and

a second jaw having a top surface; the second jaw being movable relative to the first jaw and having a closed position in which the anvil surface is adjacent to a top surface and a gap is defined between the top surface and the anvil surface; the second jaw having a first surface and a second surface substantially parallel to each other and perpendicular to the top surface; the first surface and second surface defining a first slot between the first surface and the second surface extending along a length of the second jaw; the first slot having a slot width; the first surface having a plurality of recesses formed into the first surface; each recess having a recessed wall, a front sidewall, and a rear sidewall; the second jaw including a plurality of staple pockets; each staple pocket being defined by the recessed wall, front sidewall, rear sidewall, a bottom wall, second surface and an opening to the top surface of the second jaw;

an actuator coupled to the handle assembly;

a first coming surface having a thickness; the first coming surface being movable by the actuator within the first slot and along a length of the second jaw; and

a plurality of staples positioned in the plurality of staple pockets; each staple having a staple width and being positioned within a pocket such that a portion of the staple width resides within the first slot and a portion of the staple width is located in the recess of the first surface;

wherein, with translation of the first coming surface within the first slot, the first coming surface passes through one or more staple pockets making contact with that portion of the staple width resident within the first slot to urge the staple out of the opening and against the anvil surface.

2. The surgical stapler of claim 1 wherein the first coming surface is angled with respect to the top surface and the front sidewall and rear sidewall is perpendicular to the angled first coming surface.

3. The surgical stapler of claim 1 wherein each staple includes a first leg interconnected by a base to a second leg; the staple being substantially U-shaped in an open configuration; the first leg having a distal tip and the second leg having a distal tip; the first leg being shorter in length relative to the longer second leg; the staple being positioned within the recess such that the first leg is adjacent to the front sidewall and the second leg is adjacent to the rear sidewall;

wherein the anvil surface is a smooth surface without pockets and the second leg is deformed toward the first leg into a closed configuration when urged against the anvil surface by the translating first coming surface;

wherein the distal tip of the second leg slides along the anvil surface from the open configuration to the closed configuration.

4. The surgical stapler of claim 1 wherein the second surface includes a plurality of recesses formed into the second surface opposite from the plurality of recesses formed into the first surface; each recess in the second surface includes a recessed wall, a front sidewall, a rear sidewall and a bottom wall; each staple pocket being defined by the recessed wall, front sidewall, rear sidewall and the bottom wall formed in the first surface and the recessed wall, front sidewall, rear sidewall and bottom wall formed in the second surface; the plurality of staples being positioned in the plurality of staple pockets such that a portion of each staple is located in the recess of the first surface and a portion of each staple is located in the recess of the second surface.

5. The surgical stapler of claim 1 wherein the bottom wall is formed in the first surface and includes a gap between the bottom wall and the front sidewall.

6. The surgical stapler of claim 1 wherein the first surface is a side of an elongated first plate and the second surface is a side of an adjacent elongated second plate; the first plate being adjacent to the second plate.

7. The surgical stapler of claim 1 wherein the first plate includes at least one spacer extending from the first surface toward the second surface.

8. The surgical stapler of claim 1 wherein the second jaw includes a third surface and a fourth surface substantially parallel to each other and perpendicular to the top surface; the third surface and fourth surface defining a second slot between the third surface and fourth surface and extending along a length of the second jaw; the fourth surface having a plurality of recesses formed into the fourth surface; each recess having a recessed wall, a front sidewall, and a rear sidewall; the second jaw includes a plurality of second slot staple pockets; each second slot staple pocket being defined

by the recessed wall, front sidewall, rear sidewall, a bottom wall, third surface and an opening to the top surface of the second jaw;

a second caming surface having a thickness; the second caming surface being movable by the actuator within the second slot along a length of the second jaw; and

a plurality of staples positioned in the plurality of the second slot staple pockets such that a portion of the staple width resides within the second slot and a portion of the staple width is located in the recess of the fourth surface.

9. The surgical stapler of claim 8 further including a blade movable along a length of the jaw assembly and within the gap defined between the top surface and the anvil surface when the first jaw and second jaw are in the closed position; the blade being located between the first caming surface and the second caming surface.

10. The surgical stapler of claim 8 further including a blade being movable along a length of the jaw assembly and within the gap defined between the top surface and the anvil surface when the first jaw and second jaw are in the closed position; the first caming surface and the second caming surface are located on one side of the blade.

11. The surgical stapler of claim 8 wherein the first caming surface and second caming surface are connected comprising a unitary slider; the slider being connected to the actuator.

12. The surgical stapler of claim 8 wherein the second surface and third surface are opposite sides of a single elongated plate.

13. The surgical stapler of claim 8 wherein the first surface is a side of an elongated first plate; the second surface and third surface are opposite sides of an elongated second plate; and the fourth surface is a side of an elongated third plate.

14. A surgical stapler comprising:

a handle assembly;

a cartridge assembly connected to the handle assembly; the cartridge assembly having a proximal end and a distal end; the cartridge assembly comprising;

a jaw assembly at the distal end of the cartridge assembly; the jaw assembly having a longitudinal axis; the jaw assembly comprising;

a first jaw having an anvil surface; the anvil surface being a smooth and flat surface without pockets; and

a second jaw having a top surface; the second jaw being movable relative to the first jaw and having a closed position in which the anvil surface is adjacent to a top surface and a gap is defined between the top surface and the anvil surface; the second jaw including a plurality of staple pockets; each staple pocket having a longitudinal axis and an opening at the top surface;

an actuator coupled to the handle assembly;

at least one caming surface movable by the actuator within the second jaw and along a length of the second jaw

a plurality of staples positioned in the staple pockets; each staple having an open configuration for penetrating tissue and a closed configuration for retaining tissue; the plurality of staples being located inside the staple pockets in an open configuration;

wherein, with the jaw assembly in a closed position, translation of the caming surface along the second jaw ejects the staples from the staple pockets toward the anvil surface of the first jaw to deform the staples from an open configuration against the anvil surface to a closed configuration.

15. The surgical stapler of claim 14 wherein each staple includes at least a first leg and a second leg interconnected by base; and

wherein the first leg has a distal end and the second leg has a distal end and the first leg of each staple is shorter in length relative to the second leg;

wherein the second leg is deformed toward the first leg into a closed configuration when urged against the anvil surface by the translating first caming surface.

16. The surgical stapler of claim 15 wherein the longitudinal axis of each staple pocket is angled with respect to the top surface such that the second leg contacts the anvil surface before the first leg and the distal tip of the second leg slides along the anvil surface; the second leg being deformed while a portion of the staple including the first leg remains substantially contained in the staple pocket.

17. The surgical stapler of claim 15 wherein the distal end of the second leg is chamfered or curved toward the first leg to provide a predilection for the staple to bend toward the first leg.

18. A surgical stapler comprising:

a handle assembly;

a cartridge assembly connected to the handle assembly; the cartridge assembly having a proximal end and a distal end; the cartridge assembly comprising;

a jaw assembly at the distal end of the cartridge assembly; the jaw assembly having a longitudinal axis; the jaw assembly comprising;

a first jaw having an anvil surface; and

a second jaw having a top surface; the second jaw being movable relative to the first jaw and having a closed position in which the anvil surface is adjacent to a top surface and a gap is defined between the top surface and the anvil surface; the second jaw including a plurality of staple pockets having a plurality of openings at the top surface; the staple pockets being arranged in at least three substantially parallel rows along the top surface of the second jaw;

an actuator coupled to the handle assembly;

at least one caming surface movable by the actuator along a length of the second jaw;

a blade movable within the gap defined between the top surface and the anvil surface when the first jaw and second jaw are in the closed position; the blade being configured to sever tissue located between the first jaw and the second jaw defining a cutting line;

a plurality of staples positioned inside the plurality of staple pockets;

wherein the caming surface is configured to eject staples from the staple pockets and against the anvil surface to deform the staples with translation of the caming surface along the second jaw;

wherein the second jaw includes a number of rows of staple pockets on one side of the blade that is different from a number of rows of staple pockets on the other side of the blade.

19. The surgical stapler of claim 18 further including a visual indication on the outer surface of jaw assembly to indicate to the user which side of the jaw assembly delivers fewer rows of staples.

20. The surgical stapler of claim 18 wherein the jaw assembly is curved.

专利名称(译)	带有部分口袋的外科缝合器		
公开(公告)号	<a href="#">US20140263570A1</a>	公开(公告)日	2014-09-18
申请号	US14/212357	申请日	2014-03-14
[标]申请(专利权)人(译)	应用医疗资源		
申请(专利权)人(译)	应用医疗资源CORPORATION		
当前申请(专利权)人(译)	应用医疗资源CORPORATION		
[标]发明人	HOPKINS TIMOTHY GADBERRY DONALD L BECERRA MATTHEW M JASEMIAN BABAK JOHNSON GARY M DECKER STEVEN E		
发明人	HOPKINS, TIMOTHY GADBERRY, DONALD L. BECERRA, MATTHEW M. JASEMIAN, BABAK JOHNSON, GARY M. DECKER, STEVEN E.		
IPC分类号	A61B17/072		
CPC分类号	A61B17/07207 A61B17/0644 A61B2017/0641 A61B2017/07221 A61B2017/07228 A61B2017/07264 A61B2017/07278 A61B2017/07285		
优先权	61/785100 2013-03-14 US		
其他公开文献	US9872683		
外部链接	<a href="#">Espacenet</a> <a href="#">USPTO</a>		

摘要(译)

外科缝合器包括在远端处连接到手柄组件的钳口组件，该手柄组件构造控制吻合器并致动钉的展开。外科缝合器成功地消除了通常称为推动器的中间定位部分，所述推动器位于钉和平移滑动器之间。钉以一定角度定位在凹穴中，使得钉的基部平行于滑块的成角度的游戏表面。当滑块移动通过每个钉仓时，平移滑块在展开期间与钉直接接触，其中钉沿着滑块路径部分地由凹槽支撑。钉以与砧座表面成一定角度展开。由于没有推动器，节省了大量空间，因此直径小得多的外科缝合器特别适用于腹腔镜缝合应用。

