



US 20130325004A1

(19) **United States**

(12) **Patent Application Publication**
Greep

(10) **Pub. No.: US 2013/0325004 A1**

(43) **Pub. Date: Dec. 5, 2013**

(54) **ELECTROSURGICAL SCISSORS**

(57) **ABSTRACT**

(76) Inventor: **Darcy W. Greep**, Herriman, UT (US)

Embodiments are directed to various monopolar and bipolar electro-surgical scissor instruments. A monopolar electro-surgical scissor instrument includes one scissor blade that has an electrically conductive tapered edge, where the tapered edge is insufficiently sharp to shear or otherwise mechanically cut tissue. The scissors also include another electrically insulated scissor blade movably mounted to the first scissor blade. The second scissor blade includes a flat contact surface that is aligned with the tapered edge of the first scissor blade. The scissors further include a scissor body that includes a conductor that transfers electrical energy from an energy source to the tapered edge of the first electrically conductive scissor blade to electrically cut interlaying tissue located between the first electrically conductive scissor blade and the second electrically insulated scissor blade.

(21) Appl. No.: **13/486,524**

(22) Filed: **Jun. 1, 2012**

Publication Classification

(51) **Int. Cl.**
A61B 18/14 (2006.01)

(52) **U.S. Cl.**
USPC **606/48; 606/45**

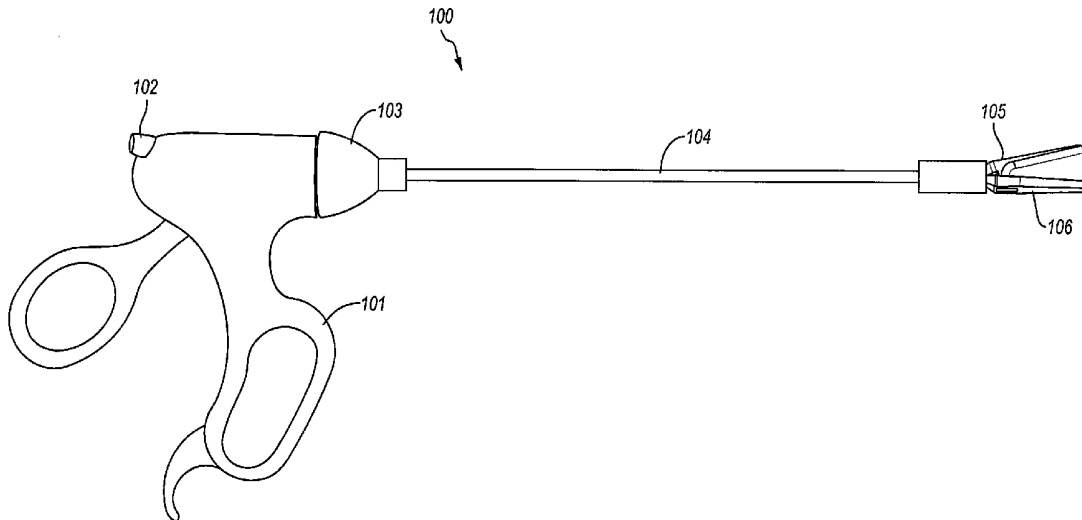

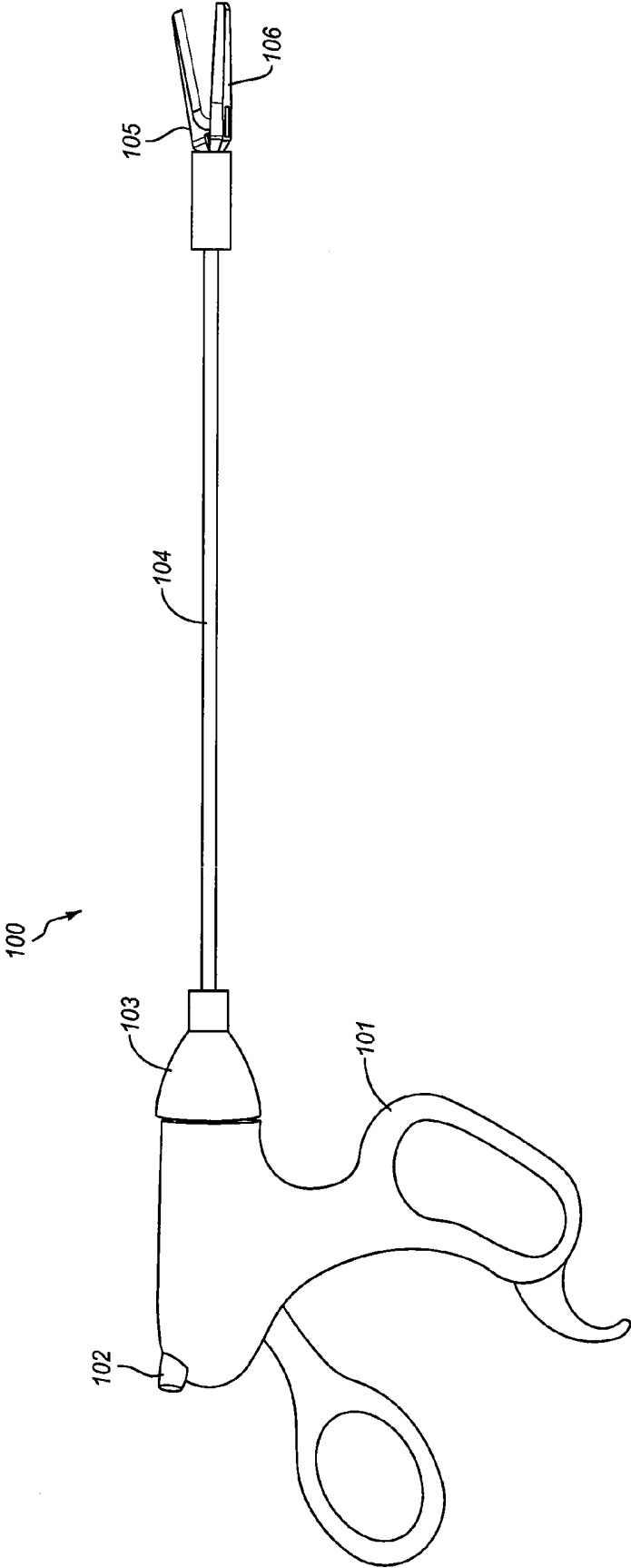

Fig. 1

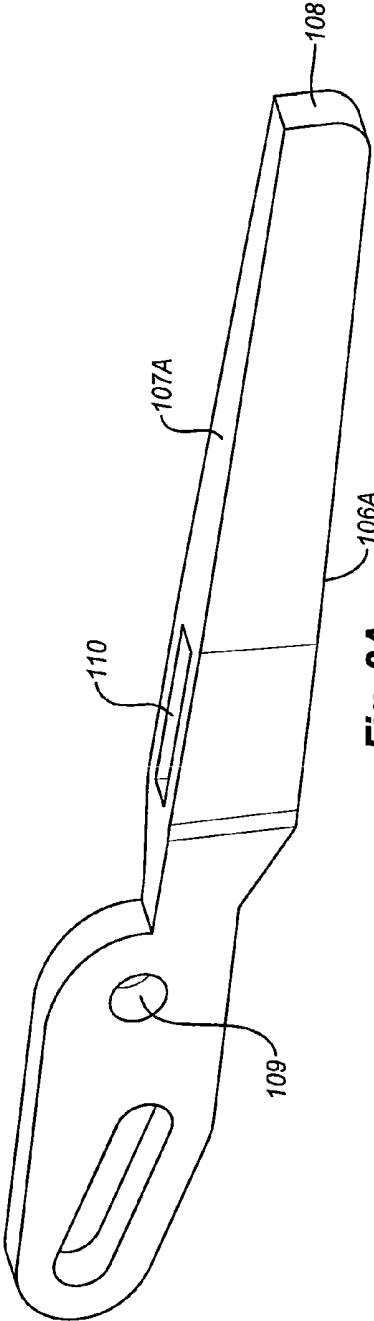

Fig. 2A

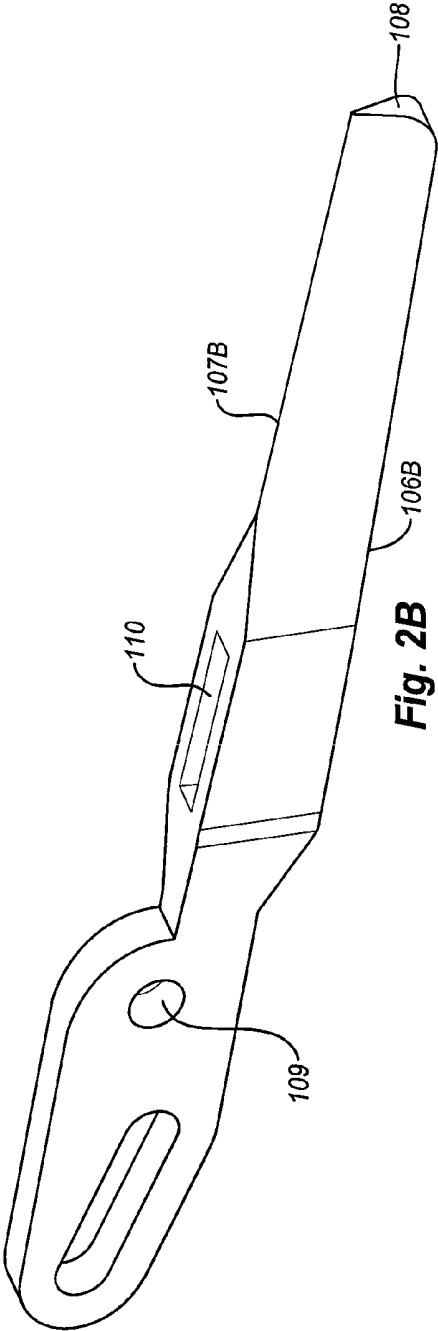

Fig. 2B

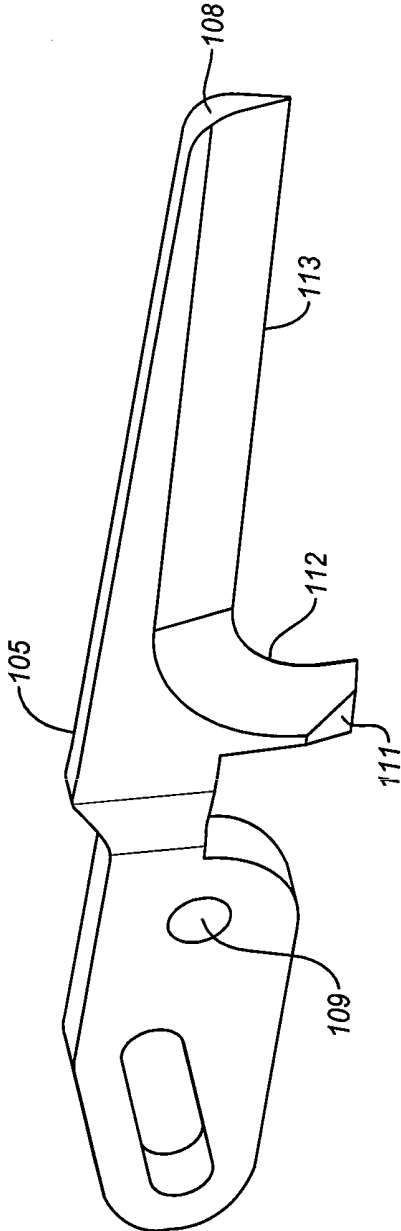

Fig. 3

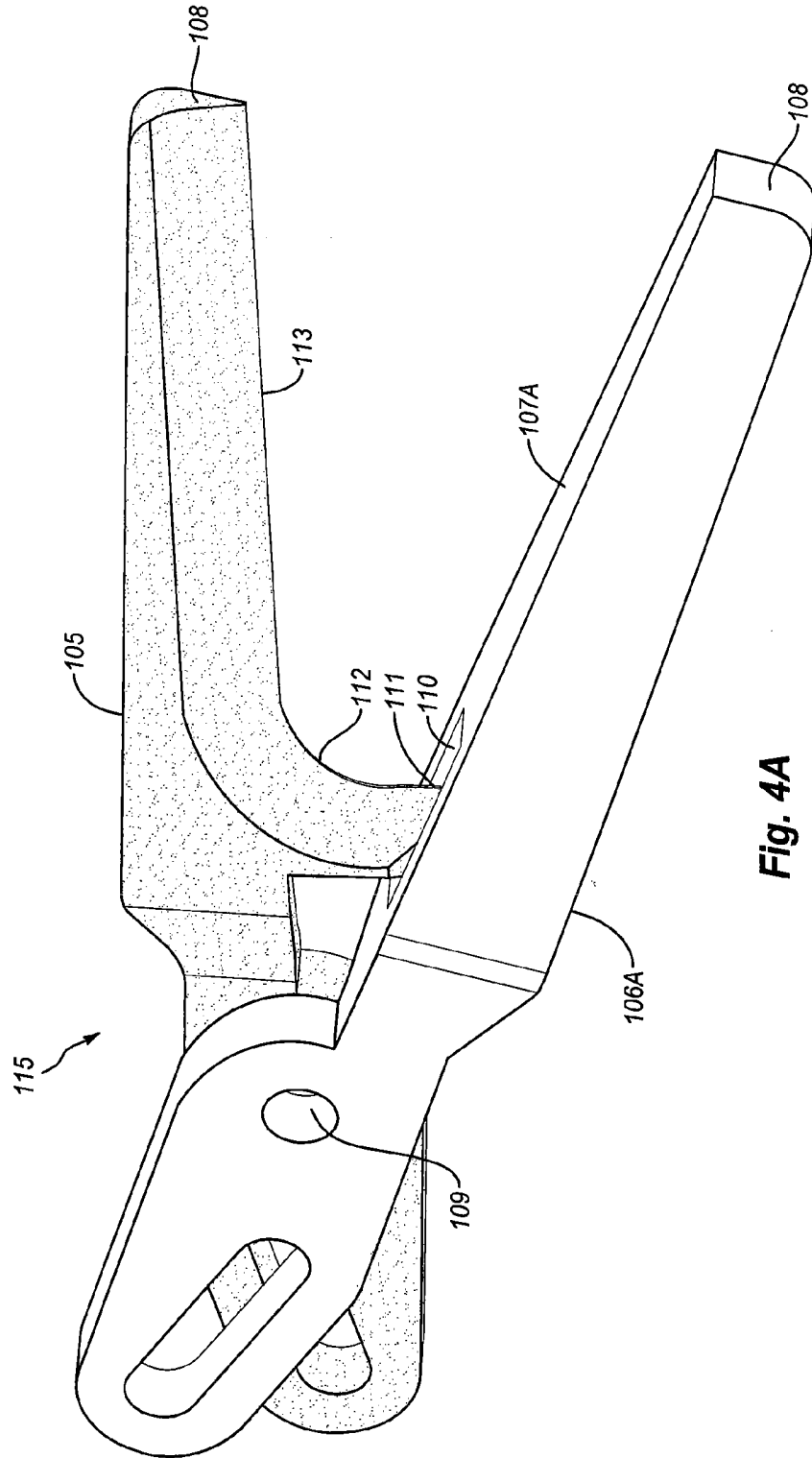

Fig. 4A

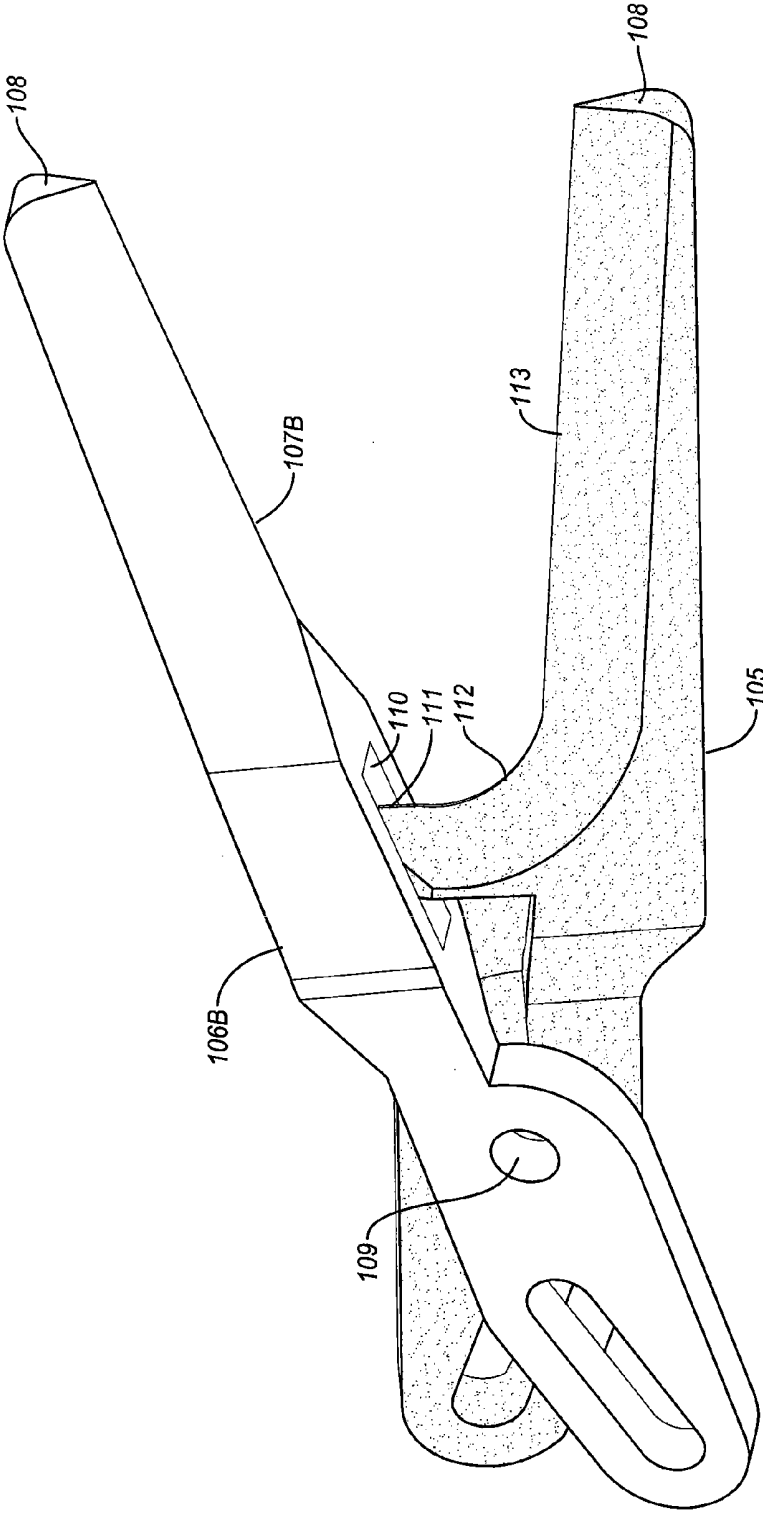

Fig. 4B

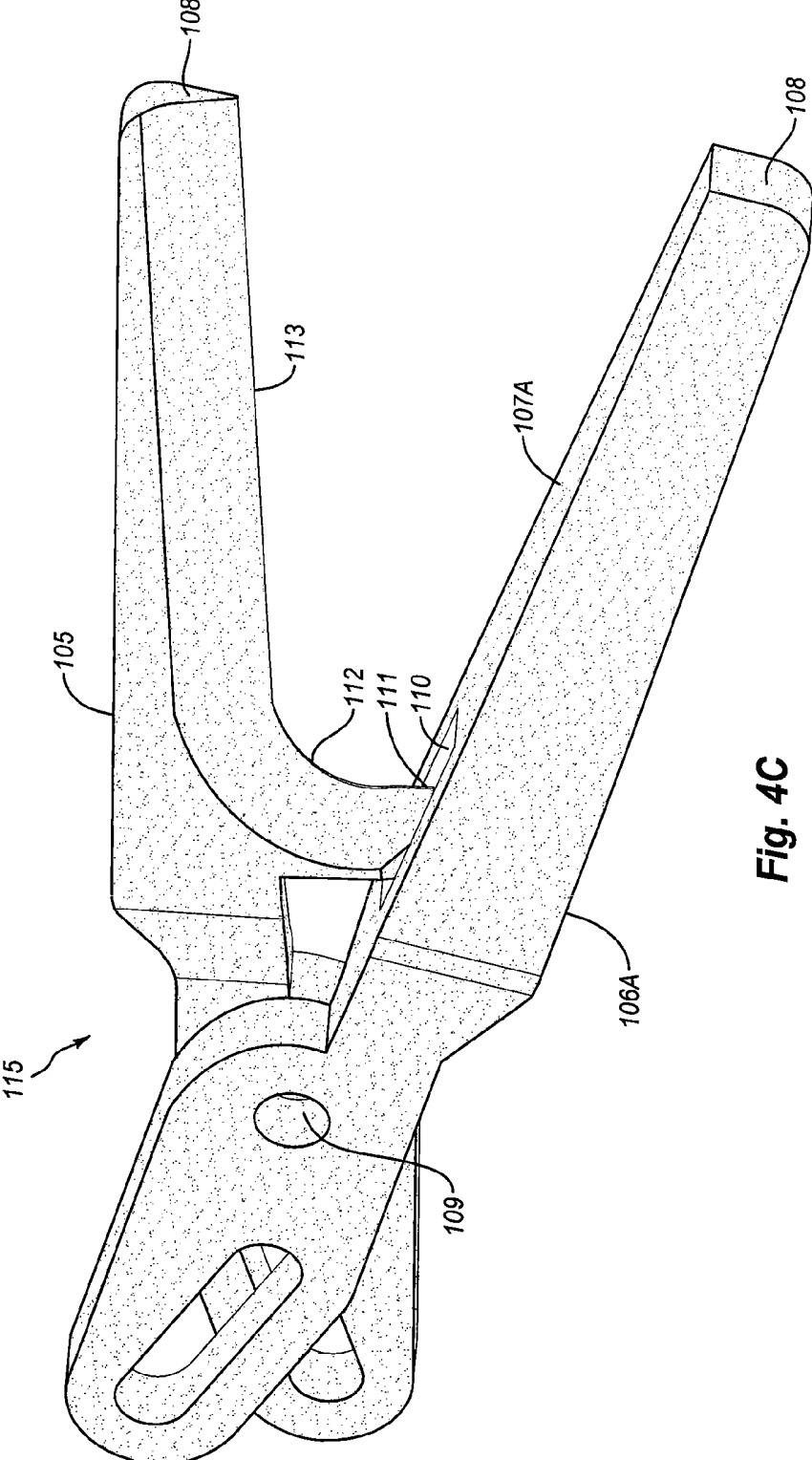

Fig. 4C

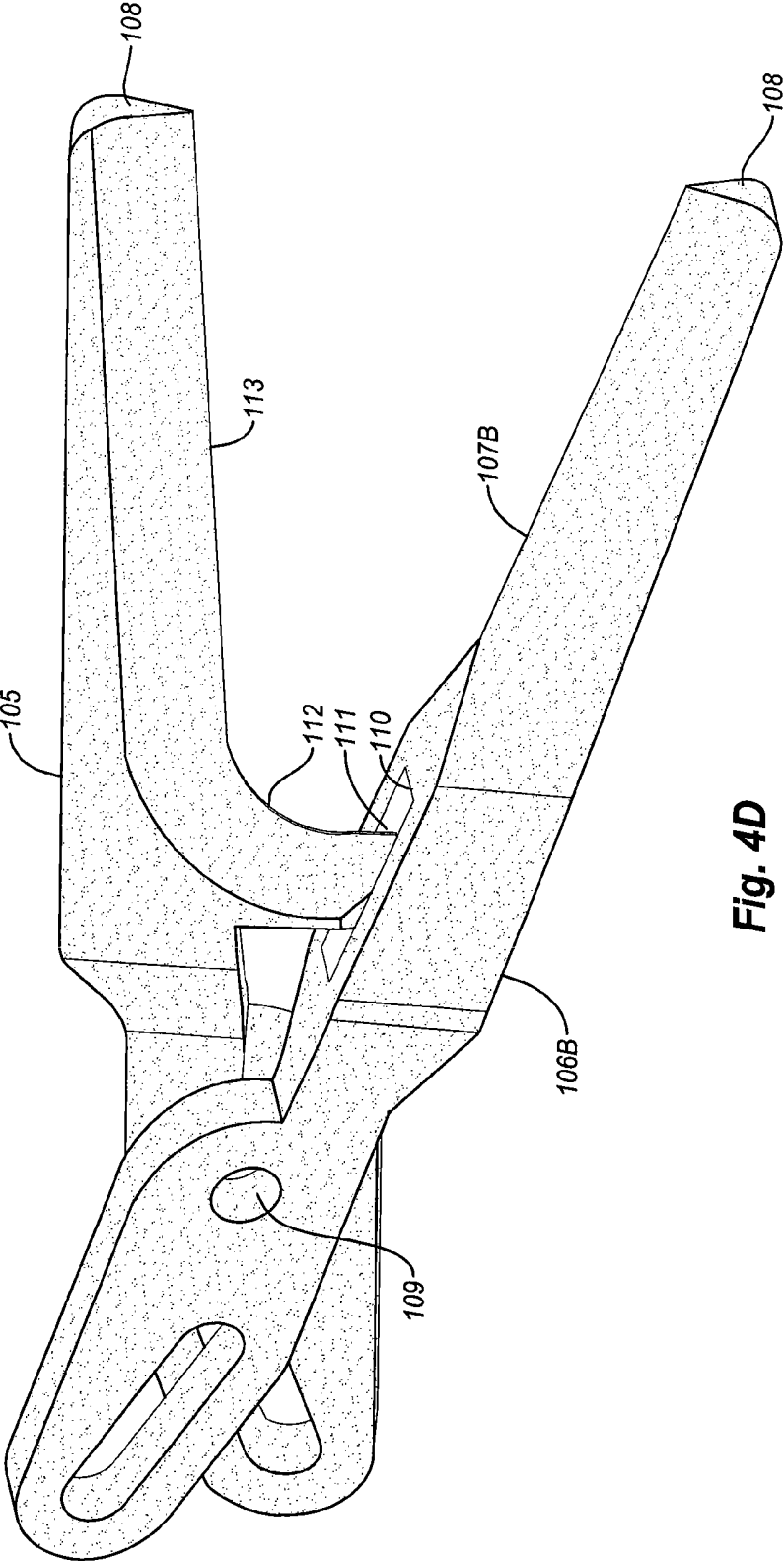

Fig. 4D

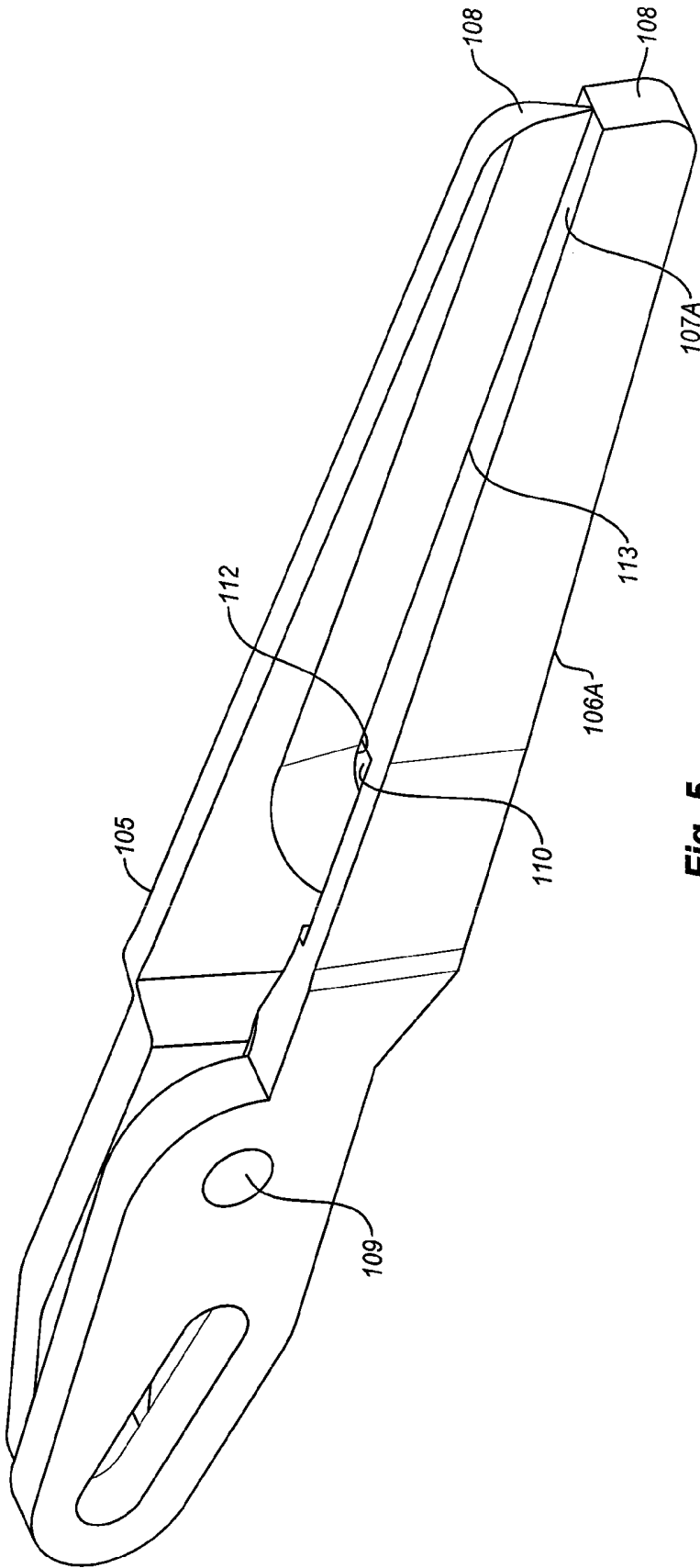

Fig. 5

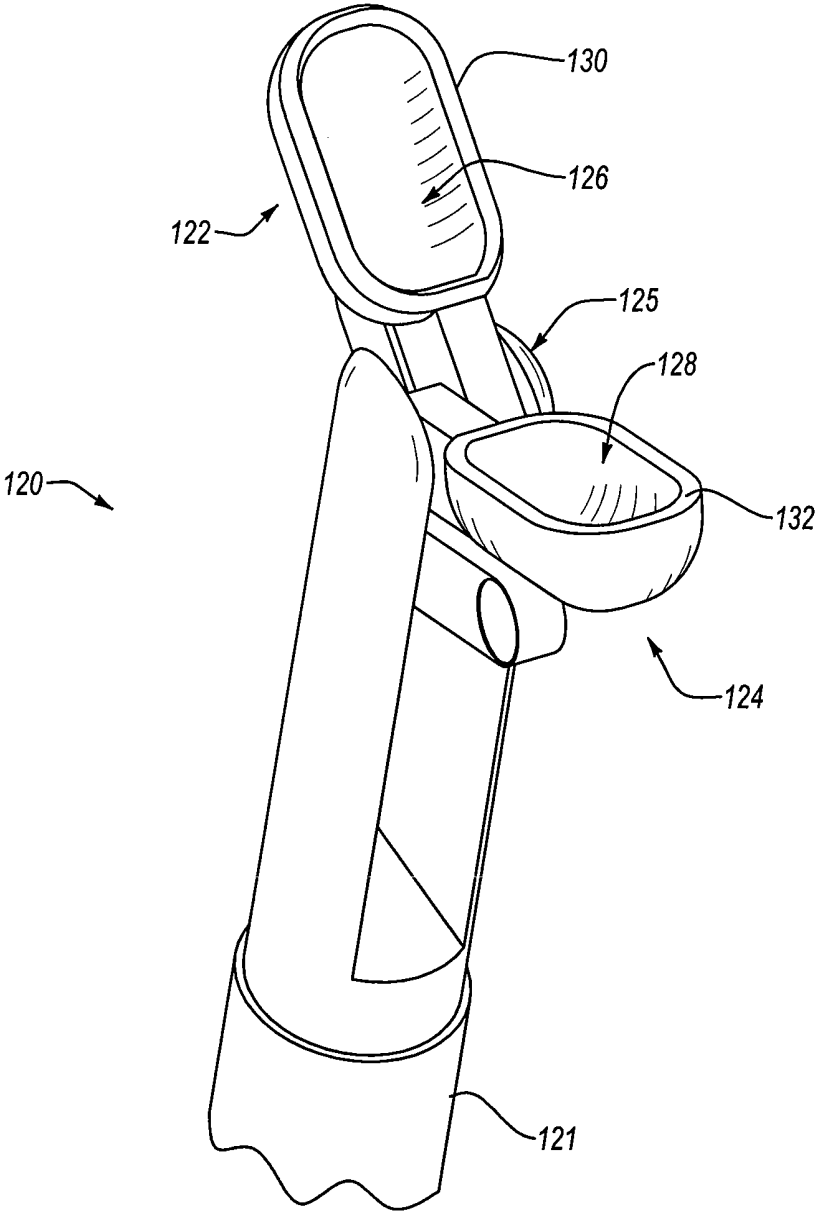

Fig. 6

ELECTROSURGICAL SCISSORS

BACKGROUND

[0001] Historically, tissue has been cut with scissors of various designs by a mechanical shearing action as sharpened blades move past each other on closing. The mechanical limitations of typical scissor designs and the variation in tissue types result in the following problems and complications: tissue squeezing out of the scissor on compression (“popping out”); incomplete cuts; cut edges that are uneven (caused by dull scissors or changes in tissue type); the inability to see/determine exactly what is being cut; separation and jamming of scissor blades without cutting tissue when fibrous, fatty, or tough tissue gets caught between blades; and dulling of the scissors due to limitations of materials and mechanisms. Additionally, the sharp blades of traditional scissors may inadvertently nick or damage other tissues or structures, such as nerves, blood vessels, tendons, sutures, implanted electrical leads (pacemaker, defibrillator, neural stim, etc.) and surgical personnel. Furthermore, general scissor designs do not provide a mechanism to stop bleeding once tissue has been cut.

[0002] With the advent of electrosurgery, both monopolar and bipolar scissor designs have been produced to allow for application of electrical energy to stop bleeding after tissue has been cut with the scissors. These designs have attempted to combine both the mechanical shearing action of a regular scissor and the application functionality of electrosurgical energy in both cut and coagulation modes. However, attempts to concentrate electrical energy in a focused manner to enhance the cutting effect have been sparse. Indeed, most efforts have been with bipolar instruments which typically attempt to achieve a small activation zone effect through optimal electrode distances and placement.

BRIEF SUMMARY

[0003] Embodiments described herein are directed to various monopolar and bipolar electrosurgical scissor instruments. In one embodiment, a monopolar electrosurgical scissor instrument includes one scissor blade that has an electrically conductive tapered edge that is insufficiently sharp to shear or otherwise mechanically cut tissue. The scissors also include another electrically insulated scissor blade movably mounted to the first scissor blade. The second scissor blade includes a contact surface that is aligned with the tapered edge of the first scissor blade. The contact surface of the second scissor blade may be a substantially flat edge or a tapered edge. The scissors further include a scissor body that is or has a conductor that selectively transfers electrical energy from an energy source to the tapered edge of the first electrically conductive scissor blade to electrically cut interlaying tissue located between the first electrically conductive scissor blade and the second electrically insulated scissor blade. The scissor body may also include a switch for selectively activating the energy source that supplies electrical energy to the scissor. Conversely, the switch may be located separately from the scissor such as a footswitch activation mechanism.

[0004] In another embodiment, an alternative monopolar electrosurgical scissor instrument is provided. The scissors include a scissor blade that has an electrically conductive tapered edge that is insufficiently sharp to shear or otherwise mechanically cut tissue. The scissors also include a second

electrically conductive scissor blade movably mounted to the first scissor blade. The second scissor blade includes a contact surface that is aligned with the tapered edge of the first scissor blade. The contact surface of the second scissor blade may be a substantially flat edge or a tapered edge. The first scissor blade and the second scissor blade are electrically connected to one another. The scissors further include a scissor body that is or has a conductor that transfers a monopolar output signal from an energy source to the tapered edge of the first electrically conductive scissor blade to electrically cut interlaying tissue located between the first electrically conductive scissor blade and the second electrically conductive scissor blade. The scissor body may also include a switch for selectively activating the energy source that supplies electrical energy to the scissor. Conversely, the switch may be located separately from the scissor such as a footswitch activation mechanism.

[0005] In another embodiment, an alternative monopolar electrosurgical scissor instrument is provided. The scissors include a scissor blade that has an electrically conductive tapered edge that is insufficiently sharp to shear or otherwise mechanically cut tissue. The scissors also include a second electrically conductive scissor blade movably mounted to the first scissor blade. The second scissor blade includes a contact surface that is aligned with the tapered edge of the first scissor blade. The contact surface of the second scissor blade may be a substantially flat edge or a tapered edge. The first scissor blade and the second scissor blade are electrically insulated from one another. A minimum clearance space is provided between the first and second blades to prevent the first and second blades from touching. The scissors further include a scissor body that is or has a conductor that transfers a monopolar output signal from an energy source to the tapered edge of the first electrically conductive scissor blade to electrically cut interlaying tissue located between the first electrically conductive scissor blade and the second electrically conductive scissor blade. The scissor body may also include a switch for selectively activating the energy source that supplies electrical energy to the scissor. Conversely, the switch may be located separately from the scissor such as a footswitch activation mechanism.

[0006] In another embodiment, an alternative monopolar electrosurgical scissor instrument is provided. The scissors include a scissor blade that has an electrically conductive tapered edge that is insufficiently sharp to shear or otherwise mechanically cut tissue. The scissors also include a second electrically conductive scissor blade movably mounted to the first scissor blade. The second scissor blade includes a contact surface that is aligned with the tapered edge of the first scissor blade. The contact surface of the second scissor blade may be a substantially flat edge or a tapered edge. The first scissor blade and the second scissor blade are electrically insulated from one another. A minimum clearance space is provided between the first and second blades to prevent the first and second blades from touching. The scissors further include a scissor body that is or has two conductors. One conductor selectively transfers a monopolar output signal from an energy source to the tapered edge of the first electrically conductive scissor blade. The second conductor acts as a return lead for the monopolar signal and electrically connects the second electrically conductive scissor blade to the return input of the ESU. When activated this arrangement serves to electrically cut interlaying tissue located between the first electrically conductive scissor blade and the second electrically conductive scissor blade. The scissor body may also

include a switch for selectively activating the energy source that supplies electrical energy to the first scissor blade. Conversely, the switch may be located separately from the scissor such as a footswitch activation mechanism.

[0007] In still another embodiment, a bipolar electro-surgical scissor instrument is provided. The scissors include a scissor blade that has an electrically conductive tapered edge that is insufficiently sharp to shear or otherwise mechanically cut tissue. The scissors also include a second electrically conductive scissor blade being movably mounted to the first electrically conductive scissor blade. The second scissor blade has a contact surface that is aligned with the tapered edge of the first scissor blade. The contact surface of the second scissor blade may be a substantially flat edge or a tapered edge. The scissors also include a scissor body that is or has conductors that transfer electrical energy from an energy source to the tapered edge of the first electrically conductive first scissor blade in a first polarity and transfers electrical energy to the substantially flat contact surface of the second scissor blade in a second polarity that is opposite from the first polarity. The transferred energy electrically cuts interlaying tissue located between the first electrically conductive scissor blade and the second electrically conductive scissor blade. The scissor body may also include a switch for selectively activating the energy source that supplies electrical energy to the scissor. Conversely, the switch may be located separately from the scissor such as a footswitch activation mechanism.

[0008] This Summary is provided to introduce a selection of concepts in a simplified form that are further described below in the Detailed Description. This Summary is not intended to identify key features or essential features of the claimed subject matter, nor is it intended to be used as an aid in determining the scope of the claimed subject matter.

[0009] Additional features and advantages will be set forth in the description which follows, and in part will be apparent to one of ordinary skill in the art from the description, or may be learned by the practice of the teachings herein. Features and advantages of embodiments of the invention may be realized and obtained by means of the instruments and combinations particularly pointed out in the appended claims. Features of the embodiments of the present invention will become more fully apparent from the following description and appended claims, or may be learned by the practice of the invention as set forth hereinafter.

BRIEF DESCRIPTION OF THE DRAWINGS

[0010] To further clarify the above and other advantages and features of embodiments of the present invention, a more particular description of embodiments of the present invention will be rendered by reference to the appended drawings. It is appreciated that these drawings depict only typical embodiments of the invention and are therefore not to be considered limiting of its scope. The embodiments of the invention will be described and explained with additional specificity and detail through the use of the accompanying drawings in which:

[0011] FIG. 1 illustrates a side view of a laparoscopic electro-surgical device according to one embodiment.

[0012] FIG. 2A illustrates an isometric view of an electro-surgical scissor blade with a substantially flat top surface.

[0013] FIG. 2B illustrates an isometric view of an electro-surgical scissor blade with a tapered top surface.

[0014] FIG. 3 illustrates an isometric view of an electro-surgical scissor blade with a tapered bottom surface.

[0015] FIG. 4A illustrates an isometric view of two electro-surgical scissor blades in which the top blade is powered with electrical energy.

[0016] FIG. 4B illustrates an isometric view of two electro-surgical scissor blades in which the bottom blade is powered with electrical energy.

[0017] FIG. 4C illustrates an isometric view of two electro-surgical scissor blades in which both the top and bottom blades are powered with electrical energy, and where the bottom blade has a substantially flat top surface.

[0018] FIG. 4D illustrates an isometric view of two electro-surgical scissor blades in which both the top and bottom blades are powered with electrical energy, and where the bottom blade has a tapered top surface.

[0019] FIG. 5 illustrates an isometric view of two electro-surgical scissor blades in a closed position.

[0020] FIG. 6 illustrates an isometric view of a biopsy cutter device according to one embodiment.

DETAILED DESCRIPTION

[0021] Embodiments described herein are directed to various monopolar and bipolar electro-surgical scissor instruments. In one embodiment, a monopolar electro-surgical scissor instrument includes one scissor blade that has an electrically conductive tapered edge that is insufficiently sharp to shear or otherwise mechanically cut through tissue. The scissors also include another electrically insulated scissor blade movably mounted to the first scissor blade. The second scissor blade includes a contact surface that is aligned with the tapered edge of the first scissor blade. The contact surface of the second scissor blade may be a substantially flat edge or a tapered edge. The scissors further include a scissor body that is or has a conductor that transfers electrical energy from an energy source to the tapered edge of the first electrically conductive scissor blade to electrically cut interlaying tissue located between the first electrically conductive scissor blade and the second electrically insulated scissor blade. The scissor body may also include a switch for selectively activating the energy source that supplies electrical energy to the scissor. Conversely, the switch may be located separately from the scissor such as a footswitch activation mechanism.

[0022] In another embodiment, an alternative monopolar electro-surgical scissor instrument is provided. The scissors include a scissor blade that has an electrically conductive tapered edge that is insufficiently sharp to shear or otherwise mechanically cut through tissue. The scissors also include a second electrically conductive scissor blade movably mounted to the first scissor blade. The second scissor blade includes a contact surface that is aligned with the tapered edge of the first scissor blade. The contact surface of the second scissor blade may be a substantially flat edge or a tapered edge. The first scissor blade and the second scissor blade are electrically insulated from one another. A minimum clearance space is provided between the first and second blades to prevent the first and second blades from touching. The scissors further include a scissor body that is or has a conductor that transfers a monopolar output signal from an energy source to the tapered edge of the first electrically conductive scissor blade to electrically cut interlaying tissue located between the first electrically conductive scissor blade and the second electrically conductive scissor blade. The scissor body may also include a switch for selectively activating the

energy source that supplies electrical energy to the scissor. Conversely, the switch may be located separately from the scissor such as a footswitch activation mechanism.

[0023] In another embodiment, an alternative monopolar electro-surgical scissor instrument is provided. The scissors include a scissor blade that has an electrically conductive tapered edge that is insufficiently sharp to shear or otherwise mechanically cut through tissue. The scissors also include a second electrically conductive scissor blade movably mounted to the first scissor blade. The second scissor blade includes a contact surface that is aligned with the tapered edge of the first scissor blade. The contact surface of the second scissor blade may be a substantially flat edge or a tapered edge. The first scissor blade and the second scissor blade are electrically insulated from one another. A minimum clearance space is provided between the first and second blades to prevent the first and second blades from touching. The scissors further include a scissor body that is or has two conductors. One conductor transfers a monopolar output signal from an energy source to the tapered edge of the first electrically conductive scissor blade. The second conductor acts as a return lead for the monopolar signal and electrically connects the second electrically conductive scissor blade to the return input of the ESU. The first conductor selectively transfers a monopolar output signal from an energy source to the tapered edge of the first electrically conductive scissor blade to electrically cut interlaying tissue located between the first electrically conductive scissor blade and the second electrically conductive scissor blade. The scissor body may also include a switch for selectively activating the energy source that supplies electrical energy to the scissor. Conversely, the switch may be located separately from the scissor such as a footswitch activation mechanism.

[0024] In still another embodiment, a bipolar electro-surgical scissor instrument is provided. The scissors include a scissor blade that has an electrically conductive tapered edge that is insufficiently sharp to shear or otherwise mechanically cut tissue. The scissors also include a second electrically conductive scissor blade being movably mounted to the first electrically conductive scissor blade. The second scissor blade has a contact surface that is aligned with the tapered edge of the first scissor blade. The contact surface of the second scissor blade may be a substantially flat edge or a tapered edge. The scissors also include a scissor body that is or has a conductor that transfers electrical energy from an energy source to the tapered edge of the first electrically conductive first scissor blade in a first polarity and transfers electrical energy to the substantially flat contact surface of the second scissor blade in a second polarity that is opposite from the first polarity. The transferred energy electrically cuts interlaying tissue located between the first electrically conductive scissor blade and the second electrically conductive scissor blade. The scissor body may also include a switch for selectively activating the energy source that supplies electrical energy to the scissor. Conversely, the switch may be located separately from the scissor such as a footswitch activation mechanism.

[0025] Each of the above embodiments will be described with reference to FIGS. 1-5 below. FIG. 1 illustrates a laparoscopic electro-surgical device 100 that may be used in various laparoscopic or other minimally invasive surgeries. The laparoscopic electro-surgical device 100 includes various parts that function together to sever tissue, as directed by the operator (typically, a surgeon). For instance, the device 100

includes a handle 101. The handle may be designed such that squeezing the lever of the handle toward the other part of the handle activates one or both of the electro-surgical scissor blades (105 & 106). This activation may lower the top scissor blade 105 onto the bottom scissor blade 106. Additionally or alternatively, squeezing the lever of the handle may initiate the flow of electrical current to one or both of the electro-surgical scissor blades (105 & 106). In other cases, the handle 101 (or another part of the device 100) may include a separate switch or button (not shown) that initiates the flow of electrical energy to one or both of the electro-surgical blades. In still other cases, a switch mechanism such as a foot switch may be used to initiate the flow of electrical energy to one or both of the electro-surgical blades.

[0026] The handle (or any other part of the laparoscopic electro-surgical device 100) may include an input 102 for electrical energy. This electrical energy may be used to electrically cut any tissue that is between the top blade 105 and the bottom blade 106. The electrical energy is received from a local or remote power source, such as an electro-surgical generator (ESU). The power source may be designed to provide a specified amount of electrical energy or current with a specified waveform to one or both of the electro-surgical scissor blades (105 and/or 106). The electrical energy is carried over a wire or other electrical conductor through an elongated shaft 104 to the scissor blade(s). In some embodiments, the laparoscopic electro-surgical device 100 may include cap 103 that separates the handle 101 and the elongated shaft 104. In some embodiments, the shaft 104 and scissor blades 105/106 of the laparoscopic electro-surgical device 100 may be inserted into a patient's body up to the cap 103. In this manner, the scissor blades can be used to cut tissue within the patient's body, without having to make a large incision in the patient's body. As laparoscopic surgical devices are generally known in the art, the discussion below will focus on the electro-surgical blades 105 and 106.

[0027] The electro-surgical scissor blades 105 and 106 may be referred to herein as "energy concentrating scissors", "energy concentrating scissor blades", or simply "electro-surgical blades". Energy concentrating scissors use high density (highly focused) electrical energy to cut through tissue after it has been captured in the closed scissors. Because the electro-surgical blades are not sufficiently sharp to shear or otherwise mechanically cut tissue, tissue may be grasped by the scissors without cutting the tissue. The electro-surgical blades will only cut the tissue when electrical current is applied. As such, a doctor or other user may grasp the tissue between the scissor blades 105 and 106 and, after confirming the desired location, positioning, or tissue, may initiate the flow of electricity to one or both scissor blades 105/106. The electrical energy is concentrated along the tapered edge 113 (FIG. 3) of the scissor blade 105 and the blade cuts through the intervening tissue.

[0028] The energy concentrating scissors of the present disclosure present various advantages. For instance, tissue can be firmly grasped or captured in the closed electro-surgical scissors without cutting the tissue. When the tissue is firmly grasped by the closed scissors, the tissue may be retracted or pulled away from other bodily structures for viewing prior to electrically cutting the tissue (i.e. activation of electrical energy to one or both of the scissor blades). This allows the doctor or other user to identify tissues and structures that will be cut prior to actually making the cut. The doctor can even

pull tissues away from sensitive structures such as nerves, blood vessels, ducts, tendons, etc. to ensure accidental damage does not occur.

[0029] The fact that the disclosed electro-surgical scissors do not cut by mechanical shearing provides additional benefits. For instance, since a cut is made using electrical energy, there are less compression forces applied to the intervening tissue as a cut is made. As a result, the intervening tissue squeezes and “pops out” less during a cutting procedure. Additionally, the electro-surgical scissors do not become dull like mechanical shearing scissors do after repeated use. As such, tissue cuts do not become uneven due to dullness. Moreover, a change in tissue type does not affect the direction of the cut, which aids in preventing uneven edges.

[0030] Furthermore, the electro-surgical scissor blades are not mechanically sharp enough to cut tissue, structures, etc. Rather, the scissor blades are designed to only cut tissue that is in contact with a return signal path (e.g. the return path from blade 105 to blade 106). The surgeon or other user cannot accidentally cut him- or herself or other surgical personnel, or other surrounding nonconductive items such as sutures or gloves. Moreover, since scissor action of the electro-surgical scissors does not include blades moving past each other (e.g., in a mechanical shearing action), tissue does not get caught between blades and cause separation and/or jamming of the scissors.

[0031] The presently disclosed scissor blades may be coated with an insulating material. This coating or insulation may cover the entire blade, or may coat the entire blade with the exception of the concentrating edge 113 of the electro-surgical scissors. The insulating material may include one or more layers of various different materials. Examples of such materials include Polytetrafluoroethylene (PTFE), silicone, other high temperature polymers, glass, ceramic, other silica based insulating materials, etc. The coating may act as both a non-stick coating and a dielectric layer to help focus energy along the edge of the scissor blade.

[0032] Focused electrical energy produces minimal to no thermal necrosis (spread) during activation and cutting. The cut is clean and thermal damage to adjacent tissue is minimized. The electro-surgical scissors may use a relatively low amount of power to generate the cut effect (e.g. in the range of 20-50 Watts). As such, small structures and thin membranes can be safely cut without damage to neighboring tissue outside the incision line. In some embodiments, coagulation energy may also be delivered with the active scissor blade to stop bleeding at or near the cut. Vessels may even be grasped and sealed with the application of coagulation waveform energy.

[0033] The energy concentrating scissors 100 may be implemented in substantially any scissor style design, including those which currently use a mechanical shearing or cutting action to cut tissue. These styles may include, but are not limited to, hand-held scissors such as: straight tipped, curved tip, Iris scissors, Mayo scissors, Metzenbaum scissors, Dura scissors, Braun-Stadler Episiotomy scissors, micro scissors, endoscopic scissors and others. It is also applicable to laparoscopic scissors and other minimally invasive cutting instruments.

[0034] In some embodiments, the electro-surgical scissors are designed to have an electric energy concentrating edge 113. This tapered edge may have a width of about 0.2 mm or less. This allows for a sharpened edge which is not sharp enough to mechanically cut by itself, but which focuses and

concentrates the electrical energy in a way that easily cuts through tissue. A coating such as PTFE or other types of fluoropolymers, silicone, other high temperature organic polymers, glass, ceramic, organosilicones and other high temperature combination polymers, diamond, as well as any other high temperature resistant, electrically insulative materials may be used to coat or cover the scissor tip(s) 108, as well as the whole scissor body or portions of the scissor body 105. The edge of the cutting surface 113 may be fully coated, left uncoated, or cleaned of coating, depending on the insulation value and other coating characteristics of the chosen material in order to focus the electrical energy. In this way, mechanical shearing is eliminated as the cutting mechanism, and tissue may be grasped prior to cutting for evaluation and exclusion of tissues or structures that need to be protected.

[0035] FIG. 4A incorporates the elements of FIGS. 2A and 3. As shown in FIG. 4A, a monopolar electro-surgical scissor instrument 115 may be provided. The electro-surgical scissors include a top scissor blade 105 that has an electrically conductive tapered edge 113. As shown by itself in FIG. 3, the top blade 105 has a tapered edge 113 that is insufficiently sharp to mechanically shear or otherwise cut tissue. As explained above, the edge 113 may be tapered to a width of about 0.2 mm or less.

[0036] The tapered edge 113 of the top scissor blade 105 may also include a dropdown rounded corner 112. The dropdown rounded corner 112 allows continuous electro-surgical tissue cutting. Accordingly, if electrical energy is flowing to the top scissor blade 105, the dropdown rounded corner may slide through tissue, electrically cutting the tissue in a continuous motion, without requiring the scissor blades to open and close on the tissue. Like edge 113, however, the dropdown rounded corner 112 is not sharp enough to mechanically shear or otherwise cut tissue. Slide cuts are only performed when electrical energy is flowing to the scissor blade 105.

[0037] The monopolar scissors 115 also include an electrically insulated bottom scissor blade 106A that is positioned below the top blade 105 and is movably mounted to the top scissor blade. As shown in FIG. 2A, the bottom scissor blade 106A includes a substantially flat contact surface 107A that is aligned with the tapered edge 113 of the top scissor blade 105. The bottom scissor blade 106A, like the top blade 105, includes a mounting hole 109 through which a mounting pin or other fastening mechanism may be used to fasten the two scissor blades together. The scissor blades may separate (as shown in FIG. 4A) to allow the insertion of tissue between the blades. The blades may then be closed as shown in FIG. 5. The bottom scissor blade 106A includes a cavity 110 through which the interlocking portion 111 and/or a portion of the dropdown rounded corner 112 of the top blade 105 is allowed to pass. The cavity and interlocking portion may align the scissor blades to ensure that the blades do not bend or twist in response to pressure applied to the tissue. The cavity 110 may also simply allow at least a portion of the dropdown rounded corner 112 to be inserted therein as the scissors are closed.

[0038] In some cases, as shown in FIG. 2B, the bottom scissor blade 106B may have a tapered edge 107B. In such cases, both the top blade 105 and the bottom blade 106B include tapered edges (113 and 107B, respectively). As with the top scissor blade's tapered edge 113, the bottom blade's tapered edge 107B is insufficiently sharp to shear or otherwise mechanically cut tissue. The cutting occurs only when electrical energy is applied. The bottom scissor blade,

whether tapered (106B) or flat (106A) may be electrically insulated, or may be electrically conductive. Likewise, whether tapered (106B) or flat (106A), the bottom scissor blade may include a cavity 110 for receiving the dropdown rounded corner 112 of the top scissor blade 105.

[0039] The bottom scissor blade 106 may be toothed to clamp tissue between the top scissor blade 105 and the bottom scissor blade. The teeth may be substantially any shape or size, and may be arranged in any of a variety of different patterns. Additionally or alternatively, the bottom scissor blade may be U-shaped to clamp tissue between the top and bottom blades. The outside edges of the top and bottom scissor blades may be blunted to allow blunt dissections. Thus, the blunt tips 108 may be inserted into a body cavity, and the scissor blades may be used to separate tissues in the cavity without mechanically or electrically cutting those tissues.

[0040] The electrical energy used to perform the cutting in the monopolar electro-surgical device 115 may include a pulse waveform that varies the amount of current delivered to the scissor blade(s) based on a determined impedance level of the tissue. Thus, current may be delivered to the electrically conductive top scissor blade 105 to perform a cut. The current may vary depending on a measured impedance level of the tissue being cut. This impedance level may increase or decrease based on the amount or type of tissue that is currently between the top and bottom blades (105 and 106). If there is a greater amount of tissue, or if there is a denser type of tissue, more current may be sent to the blade(s). Conversely, if there is a lesser amount of tissue, or if there is a less dense type of tissue currently between the blades, less current may be sent to the blade(s) to cut the tissue. A coagulation signal may also be sent through the top electrically conductive scissor blade 105, the bottom electrically conductive scissor blade 106, or the top and bottom electrically conductive scissor blades (105 and 106) to coagulate surrounding tissues. The coagulation signal may thus be delivered through the active scissor tip(s) to help stop bleeding of cut tissues and vessels. This design may also be employed as a cutting blade for vessel sealers to cut tissue that has been, or is about to be sealed. This may, at least in some embodiments, replace mechanical cutters often used in commercial vessel sealing products.

[0041] The monopolar electro-surgical scissors 115 further include a scissor body (as shown in the laparoscopic electro-surgical device 100 of FIG. 1) that includes a switch or lever 101 that selectively transfers electrical energy from an energy source to the tapered edge 113 of the electrically conductive top scissor blade 105. When activated, electrical energy is transferred to the top scissor blade 105 which then cuts interlaying tissue located between the top electrically conductive scissor blade 105 and the bottom electrically insulated scissor blade 106A.

[0042] In another embodiment, shown in FIG. 4C, an alternative monopolar electro-surgical scissor instrument is provided. The electro-surgical scissors include a top scissor blade 105 having an electrically conductive tapered edge 113. The tapered edge 113 is insufficiently sharp to shear or otherwise mechanically cut tissue. The scissors also include a bottom electrically conductive scissor blade 106 movably mounted to the first scissor blade 105. The bottom scissor blade includes a substantially flat contact surface 107A that is aligned with the tapered edge 113 of the top scissor blade. Thus, when the top scissor blade is lowered to the flat contact surface 107A,

the two blades meet, as shown in FIG. 5. In some cases, the bottom scissor blade 106B may include a tapered edge 107B (as shown in FIG. 2B).

[0043] In this embodiment, the top scissor blade 105 and the bottom scissor blade 106 are electrically insulated from one another, and a minimum clearance space is provided between the top and bottom blades to prevent the top and bottom blades from touching when the scissor is closed. In some cases, the electro-surgical scissors may be designed to allow electrical current to be returned via an electrically conductive bottom blade. Thus, various embodiments are possible.

[0044] As shown in FIG. 4A, shading on the top blade 105 indicates that the top blade is conductive and can allow electrical current to flow through it. FIG. 4B illustrates an embodiment where the top blade 105 is insulated and the bottom blade 106B (with tapered edge 107B) is conductive (as indicated by the shading). The bottom blade 106B includes a rounded corner 112 for performing continuous cuts when power is activated. The top blade 105 includes a cavity 110 for receiving the aligning member 111 of the bottom blade 106B. The top blade may have a flat edge (107A) or a tapered edge (107B) (as shown). FIGS. 4C and 4D illustrate bipolar embodiments where both blades are conductive. FIG. 4C illustrates the case where the bottom blade 106A has a substantially flat contact surface 107A, while FIG. 4D illustrates the case where the bottom blade 106B has a tapered contact surface 107B.

[0045] As with other embodiments described above, the electro-surgical scissors 115 of FIG. 4C may include a scissor body (e.g. a laparoscopic body 100) that includes a switch or lever (e.g. handle 101) that selectively transfers a monopolar output signal from an energy source to the tapered edge 113 of the electrically conductive top scissor blade 105 to electrically cut interlaying tissue located between the electrically conductive top scissor blade 105 and the electrically conductive bottom scissor blade 106.

[0046] A vessel sealing instrument may be configured to cauterize and trim tissue. The vessel sealer may include a monopolar scissor type blade cutter such as the electro-surgical scissors shown in FIG. 4A. The vessel sealing instrument may also include a monopolar signal with electrical return through other contact portions of the sealer, such as the scissors shown in FIG. 4B. As explained above, a minimal clearance is provided between blades so that the scissor blades do not touch when closed. The vessel sealing instrument may further include a bipolar scissor type blade cutter (with the energy concentrating features outlined above), such as the scissors shown in FIG. 4C. Again here, a minimal clearance is provided between scissor blades so the blades do not touch when closed.

[0047] Other embodiments for a vessel sealer include using the dropdown curved edge 112 as a sliding cutter. The top blade is activated with electrical energy (monopolar) and pushed or pulled through the vessel tissue captured in a closed sealer clamp before or after sealing is completed. In another embodiment, a vessel sealer may be monopolar and may include a return through other contact portions of the sealer (e.g. via aligning member 111), and may be pushed or pulled through the vessel tissue captured in a closed sealer clamp before or after sealing is completed. Still further, a bipolar vessel sealer may include a sliding cutter (with energy concentrating features) that is activated to perform sliding cuts through vessel tissue captured in a closed sealer clamp before

or after sealing is completed. The bipolar vessel sealer may include contact portions for transferring electricity, or may include two isolated areas on the scissor blade itself.

[0048] In a yet another embodiment, a bipolar electro-surgical scissor instrument is provided. The scissors include a top scissor blade **105** having an electrically conductive tapered edge **113**. The tapered edge is insufficiently sharp to shear or otherwise mechanically cut tissue. The electro-surgical scissors also include a bottom electrically conductive scissor blade **106** being movably mounted to the first electrically conductive scissor blade. The second scissor blade **106A** has a substantially flat contact surface **107A** that is aligned with the tapered edge **113** of the first scissor blade. The electrically conductive bottom blade **106A** may be toothed to clamp tissue between the top scissor blade **105** and the bottom scissor blade **106B**. The bottom blade may have a flat contact surface (**107A**) (as shown in FIG. 4C) or a tapered contact surface (**107B**) (as shown in FIG. 4D).

[0049] In a bipolar implementation, the electrical energy may include a substantially continuous waveform supplying substantially continuous electrical energy to the first and second scissor blades (as opposed to the variable pulses of the monopolar implementation). As with the monopolar implementation, the bipolar electro-surgical scissors allow a surgeon or other user to close the scissors to clamp the interlaying tissue. The surgeon can then see what tissue is about to be cut. If he or she does not desire to cut, no electrical energy is applied to the blade(s), and the tissue is not cut. If, however, the user does desire to cut, the user pulls a lever or switch to activate the electrical energy. The scissors then electrically cut the tissue, without shearing it. Because the blades are not sharp enough to shear tissue, the user cannot accidentally nick surrounding tissue or other objects.

[0050] In the bipolar implementation, as with the monopolar implementation, the electro-surgical scissors include a scissor body that has a switch or lever (e.g. handle **101**) that selectively activates an electrical energy source so that electrical signal is conducted to the tapered edge **113** of the electrically conductive top scissor blade in a first polarity. Conversely, the switch may be located separate from the scissor such as a footswitch activation mechanism. The electrical energy is also transferred to the substantially flat contact surface **107A** of the bottom scissor blade in a second, different polarity that is opposite from the first polarity. The transferred energy electrically cuts interlaying tissue located between the electrically conductive top scissor blade and the electrically conductive bottom scissor blade (**106A**). In this manner, the surgeon can grasp the tissue, determine what is being cut, and then make the cut. Various different blades may be used, along with different active blade scenarios (top blade active, bottom blade active, both blades active, different sections or traces on one blade active, different sections or traces on both blades active, etc.). The blades may also include dropdown curved edges **112** to allow continuous or sliding cuts. The blunt outer edges **108** also allow the scissors to be used for blunt dissections.

[0051] Accordingly, monopolar and bipolar electro-surgical scissor embodiments are described. These electro-surgical scissors may be used to electrically cut tissue in a variety of different situations, including in laparoscopic and other minimally invasive surgeries.

[0052] Electro-surgical scissor instruments of the present invention may also take the form of scissor-type biopsy cutters. Like the embodiments discussed in connection with

FIGS. 1-5, the biopsy cutters of the present invention may be monopolar or bipolar electro-surgical instruments. The biopsy cutters of the present invention may be used to collect tissue samples for analysis. Incorporation of the principles of the present invention into the biopsy cutters enables the biopsy cutters to cut tissue faster, cleaner, and with less thermal damage to the collected tissue sample.

[0053] FIG. 6 illustrates an exemplary embodiment of a scissor-type biopsy cutter **120** that incorporates the principles of the present invention. Biopsy cutter **120** may be connected to the distal end of an elongated shaft **121**. Although not illustrated in FIG. 6, a handle similar to handle **101** may be disposed at the proximal end of elongated shaft **121** to facilitate activation of biopsy cutter **120**.

[0054] Biopsy cutter **120** has a generally clamshell-like configuration. More specifically, biopsy cutter **120** includes a first half **122** and a second half **124** connected at a hinge **125**. As first half **122** and/or second half **124** move about hinge **125**, biopsy cutter **120** opens and closes. In other words, as first half **122** and/or second half **124** move about hinge **125**, first half **122** and second half **124** are moved closer together or further apart in a scissor-like action. Thus, biopsy cutter **120** may be considered a scissor-type device. Similarly, first half **122** and second half **124** may be considered scissor blades.

[0055] As can be seen in FIG. 6, first half **122** includes a cup portion **126** and second half **124** includes a cup portion **128**. Cup portions **126**, **128** cooperate to form an interior space within biopsy cutter **120** when first half **122** and second half **124** are closed. When a tissue sample is to be retrieved, biopsy cutter **120** may be opened as shown in FIG. 6 and positioned so the desired tissue is between first half **122** and second half **124**. Biopsy cutter **120** may then be closed so that the desired tissue is positioned within the interior space formed by cup portions **126**, **128**.

[0056] Similar to the scissor instruments described above, electrical current may flow from first half **122** and/or second half **124** in order to cut out the desired tissue sample. As can be seen in FIG. 6, first half **122** includes a tapered edge **130** that extends around at least a portion of cup portion **126**. Second half **124** includes a substantially flat contact surface **132** that extends around at least a portion of cup portion **128** and that is aligned with tapered edge **130**. Like tapered edge **113** described above, tapered edge **130** may have a width of about 0.2 mm or less, which allows for a sharpened edge that is not sharp enough to mechanically cut by itself, but which focuses and concentrates the electrical energy in a way that easily cuts through tissue.

[0057] In a monopolar situation, first half **122** may be conductive such that electrical current can flow through it and second half **124** may be electrically insulated. In a bipolar situation, both first half **122** and second half **124** may be conductive.

[0058] In alternative embodiments, rather than having a substantially flat contact surface **132**, second half **124** may include a tapered edge similar to tapered edge **130**. In such an embodiment, the instrument may be configured as a monopolar instrument or a bipolar instrument. For instance, in a monopolar situation, either one of first half **122** and second half **124** may be conductive while the other is electrically insulated. In a bipolar situation, first half **122** and second half **124** are both conductive.

[0059] Also like the scissors described above in connection with FIGS. 10-5, biopsy cutter **120** may include a coating such as PTFE or other types of fluoropolymers, silicone, other

high temperature organic polymers, glass, ceramic, organo-silicones and other high temperature combination polymers, diamond, as well as any other high temperature resistant, electrically insulative materials may be used to coat or cover all or portions of first half **122** and/or second half **124**. The edge of tapered surface **130** may be fully coated, left uncoated, or cleaned of coating, depending on the insulation value and other coating characteristics of the chosen material in order to focus the electrical energy. In this way, mechanical shearing is eliminated as the cutting mechanism, and tissue may be grasped prior to cutting for evaluation and exclusion of tissues or structures that need to be protected.

[0060] The present invention may be embodied in other specific forms without departing from its spirit or essential characteristics. The described embodiments are to be considered in all respects only as illustrative and not restrictive. The scope of the invention is, therefore, indicated by the appended claims rather than by the foregoing description. All changes which come within the meaning and range of equivalency of the claims are to be embraced within their scope.

We claim:

1. A monopolar electrosurgical scissor instrument, comprising:

a first electrically conductive scissor blade having a tapered edge that concentrates electrical energy transmitted from the electrosurgical scissor instrument to patient tissue during an electrosurgical procedure, the tapered edge being insufficiently sharp to shear or mechanically cut tissue;

a second scissor blade movably mounted to the first scissor blade, the second scissor blade comprising a contact surface that is aligned with the tapered edge of the first scissor blade; and

a scissor body comprising a conductor that transfers electrical energy from an energy source to the tapered edge of the first scissor blade to electrically cut interlaying tissue located between the first scissor blade and the second scissor blade.

2. The monopolar electrosurgical scissor instrument of claim **1**, wherein the tapered edge of the first scissor blade includes a dropdown rounded corner that allows continuous electrosurgical tissue cutting.

3. The monopolar electrosurgical scissor instrument of claim **1**, wherein the second scissor blade is electrically conductive.

4. The monopolar electrosurgical scissor instrument of claim **1**, wherein the second scissor blade is electrically insulated.

5. The monopolar electrosurgical scissor instrument of claim **1**, wherein the contact surface of the second scissor blade comprises an electrically insulated tapered edge that is insufficiently sharp to shear or mechanically cut tissue.

6. The monopolar electrosurgical scissor instrument of claim **1**, wherein the contact surface of the second scissor blade comprises an electrically conductive tapered edge that is insufficiently sharp to shear or mechanically cut tissue.

7. The monopolar electrosurgical scissor instrument of claim **1**, wherein the contact surface of the second scissor blade comprises a substantially flat and electrically insulated edge.

8. The monopolar electrosurgical scissor instrument of claim **1**, wherein the contact surface of the second scissor blade comprises a substantially flat and electrically conductive edge.

9. The monopolar electrosurgical scissor instrument of claim **1**, wherein the second scissor blade is at least one of toothed and textured to clamp tissue between the first scissor blade and the second scissor blade.

10. The monopolar electrosurgical scissor instrument of claim **1**, wherein the second scissor blade is U-shaped to clamp tissue between the first scissor blade and the second scissor blade.

11. The monopolar electrosurgical scissor instrument of claim **1**, wherein the first and second scissor blades comprise outside edges that are blunted to allow for blunt dissections.

12. The monopolar electrosurgical scissor instrument of claim **1**, wherein the electrosurgical scissors comprise at least one of the following types of scissors: straight tipped, curved tip, Iris scissors, Mayo scissors, Metzenbaum scissors, Dura scissors, Braun-Stadler Episiotomy scissors, Micro scissors, endoscopic scissors, and laparoscopic scissors.

13. The monopolar electrosurgical scissor instrument of claim **1**, wherein the electrical energy comprises a pulse waveform that varies the amount of current delivered to the first scissor blade based on a determined impedance level of the interlaying tissue.

14. The monopolar electrosurgical scissor instrument of claim **1**, wherein a coagulation signal is sent through the first electrically conductive scissor blade to coagulate surrounding tissues.

15. The monopolar electrosurgical scissor instrument of claim **1**, wherein the tapered edge of the first scissor blade has a width of about 0.2 mm or less.

16. The monopolar electrosurgical scissor instrument of claim **1**, wherein the contact surface of the second scissor blade has a width of about 0.2 mm or less.

17. The monopolar electrosurgical scissor instrument of claim **1**, wherein the scissor body further comprises a switch that selectively transfers electrical energy via the conductor from the energy source to the tapered edge of the first scissor blade to electrically cut interlaying tissue located between the first scissor blade and the second scissor blade.

18. A monopolar electrosurgical scissor instrument, comprising:

a first electrically conductive scissor blade having a tapered edge that concentrates electrical energy transmitted from the electrosurgical scissor instrument to patient tissue during an electrosurgical procedure, the tapered edge being insufficiently sharp to shear or mechanically cut tissue, and the electrical energy comprising a monopolar output signal;

a second electrically conductive scissor blade movably mounted to the first scissor blade, the second scissor blade comprising a contact surface that is aligned with the tapered edge of the first scissor blade, wherein the first scissor blade and the second scissor blade are electrically insulated from one another and wherein a minimum clearance space exists between the first and second blades to prevent the first and second blades from touching; and

a scissor body comprising a conductor that transfers electrical energy from an energy source to the tapered edge of the first electrically conductive first scissor blade to electrically cut interlaying tissue located between the first electrically conductive scissor blade and the second electrically conductive scissor blade.

19. The monopolar electrosurgical scissor of claim 18, wherein the electrical energy is returned via the second electrically conductive scissor blade.

20. The monopolar electrosurgical scissor of claim 18, wherein the contact surface of the second electrically conductive scissor blade comprises a tapered edge that is insufficiently sharp to shear or mechanically cut tissue.

21. The monopolar electrosurgical scissor of claim 18, wherein the contact surface of the second electrically conductive scissor blade comprises a substantially flat edge.

22. The monopolar electrosurgical scissor of claim 18, wherein the electrosurgical scissor is implemented as at least one of a vessel sealer cutter, a biopsy cutter, and a vessel harvesting instrument.

23. The monopolar electrosurgical scissor of claim 18, wherein at least one of the tapered edge of the first electrically conductive scissor blade and the contact surface of the second electrically conductive scissor blade has a width of about 0.2 mm or less.

24. A bipolar electrosurgical scissor instrument, comprising:

a first electrically conductive scissor blade having a tapered edge that concentrates electrical energy transmitted from the electrosurgical scissor instrument to patient tissue during an electrosurgical procedure, the tapered edge being insufficiently sharp to shear or mechanically cut tissue;

a second electrically conductive scissor blade being movably mounted to the first electrically conductive scissor blade, the second scissor blade comprising a contact surface that is aligned with the tapered edge of the first scissor blade; and

a scissor body comprising a conductor that transfers electrical energy from an energy source to the tapered edge of the first electrically conductive scissor blade in a first polarity and transfers electrical energy to the contact surface of the second electrically conductive scissor blade in a second polarity that is opposite from the first polarity, wherein the transferred energy electrically cuts interlaying tissue located between the first electrically conductive scissor blade and the second electrically conductive scissor blade.

25. The bipolar electrosurgical scissor instrument of claim 24, wherein the contact surface of the second electrically conductive scissor blade is at least one of toothed and textured to clamp tissue between the first scissor blade and the second scissor blade.

26. The bipolar electrosurgical scissor instrument of claim 24, wherein the contact surface of the second electrically conductive scissor blade comprises a tapered edge that concentrates electrical energy transmitted from the electrosurgical scissor instrument to patient tissue during the electrosurgical procedure, the tapered edge of the second electrically conductive scissor blade being insufficiently sharp to shear or mechanically cut tissue.

27. The bipolar electrosurgical scissor instrument of claim 26, wherein the tapered edge of the second electrically conductive scissor blade has a width of about 0.2 mm or less.

28. The bipolar electrosurgical scissor instrument of claim 24, wherein the contact surface of the second electrically conductive scissor blade comprises a substantially flat edge.

29. The bipolar electrosurgical scissor instrument of claim 24, wherein the electrical energy comprises a substantially continuous waveform supplying substantially continuous electrical energy to the first and second scissor blades.

30. The bipolar electrosurgical scissor instrument of claim 24, wherein the tapered edge of the first electrically conductive scissor blade has a width of about 0.2 mm or less.

31. An electrosurgical biopsy cutter instrument, comprising:

an electrically conductive first half comprising a cup portion and a tapered edge that extends about at least a portion of the cup portion, wherein the tapered edge concentrates electrical energy transmitted from the electrosurgical biopsy cutter to patient tissue during an electrosurgical procedure, the tapered edge being insufficiently sharp to shear or mechanically cut tissue;

a second half that is movably relative to the first half, the second half comprising a cup portion that cooperates with the cup portion of the first half to define an interior space in which a tissue sample may be received, the second half further comprising a contact surface that extends about at least a portion of the cup portion of the second half and that is aligned with the tapered edge of the first half; and

a conductive body that transfers electrical energy from an energy source to the tapered edge of the first half to electrically cut tissue located between the first half and the second half.

32. The electrosurgical biopsy cutter instrument of claim 31, wherein the tapered edge of the first half has a width of about 0.2 mm or less.

33. The electrosurgical biopsy cutter instrument of claim 31, wherein the first half is movable relative to the second half.

34. The electrosurgical biopsy cutter instrument of claim 31, wherein the contact surface of the second half comprises a tapered edge that is insufficiently sharp to shear or mechanically cut tissue.

35. The electrosurgical biopsy cutter instrument of claim 34, wherein the tapered edge of the second half has a width of about 0.2 mm or less.

36. The electrosurgical biopsy cutter instrument of claim 31, wherein the contact surface of the second half is electrically insulative.

37. The electrosurgical biopsy cutter instrument of claim 31, wherein the contact surface of the second half is electrically conductive.

* * * * *

专利名称(译)	电外科剪刀		
公开(公告)号	US20130325004A1	公开(公告)日	2013-12-05
申请号	US13/486524	申请日	2012-06-01
[标]申请(专利权)人(译)	GREEP达西W		
申请(专利权)人(译)	GREEP, 达西W.		
当前申请(专利权)人(译)	MEGADYNE医疗产品, INC.		
[标]发明人	GREEP DARCY W		
发明人	GREEP, DARCY W.		
IPC分类号	A61B18/14		
CPC分类号	A61B18/085 A61B18/1445 A61B2018/00601 A61B2018/0072 A61B2018/00875 A61B2018/146		
其他公开文献	US9084606		
外部链接	Espacenet	USPTO	

摘要(译)

实施例涉及各种单极和双极电外科剪刀器械。单极电外科剪刀器械包括一个具有导电锥形边缘的剪刀刀片，其中锥形边缘不够锋利以剪切或以其他方式机械切割组织。剪刀还包括可移动地安装在第一剪刀片上的另一电绝缘剪刀片。第二剪刀片包括平坦的接触表面，该平坦的接触表面与第一剪刀片的锥形边缘对齐。剪刀还包括剪刀主体，剪刀主体包括导体，该导体将电能从能量源传递到第一导电剪刀片的锥形边缘，以电切割位于第一导电剪刀片和第二电绝缘剪刀片之间的交错组织。

