

US010081727B2

(12) **United States Patent**
Felsinger et al.

(10) **Patent No.:** **US 10,081,727 B2**
(45) **Date of Patent:** **Sep. 25, 2018**

(54) **SYNTHETIC TISSUE STRUCTURES FOR ELECTROSURGICAL TRAINING AND SIMULATION**

(58) **Field of Classification Search**
USPC 434/262, 267, 268, 272, 273, 274
See application file for complete search history.

(71) Applicant: **Applied Medical Resources Corporation**, Rancho Santa Margarita, CA (US)

(56) **References Cited**

U.S. PATENT DOCUMENTS

(72) Inventors: **Natasha Felsinger**, Rancho Santa Margarita, CA (US); **Sam Chehayeb**, Rancho Santa Margarita, CA (US); **Eduardo Bolanos**, Rancho Santa Margarita, CA (US)

184,573 A 11/1876 Becker
2,127,774 A 8/1938 Jacobs
(Continued)

FOREIGN PATENT DOCUMENTS

(73) Assignee: **Applied Medical Resources Corporation**, Rancho Santa Margarita, CA (US)

CN 2421706 Y 2/2001
CN 2751372 Y 1/2006
(Continued)

OTHER PUBLICATIONS

(*) Notice: Subject to any disclaimer, the term of this patent is extended or adjusted under 35 U.S.C. 154(b) by 250 days.

The International Bureau of WIPO, International Preliminary Report on Patentability for International Application No. PCT/US2016/0032292, entitled "Synthetic Tissue Structures for Electrosurgical Training and Simulation," dated Nov. 23, 2017, 2017, 8 pgs.

(Continued)

(21) Appl. No.: **15/208,873**

(22) Filed: **Jul. 13, 2016**

Primary Examiner — Kurt Fernstrom

(74) *Attorney, Agent, or Firm* — Patrick Y. Ikehara

(65) **Prior Publication Data**

US 2016/0355676 A1 Dec. 8, 2016

Related U.S. Application Data

(63) Continuation of application No. PCT/US2016/032292, filed on May 13, 2016.
(Continued)

(57) **ABSTRACT**

A surgical simulator for electrosurgical training and simulation is provided. The surgical simulator includes one or more simulated tissue structures made substantially of a hydrogel comprising a dual interpenetrating network of ionically cross-linked alginate and covalently cross-linked acrylamide. Combinations of different simulated tissue structures define procedural-based models for the practice of various electrosurgical procedures including laparoscopic total mesorectal excision, transanal total mesorectal excision, cholecystectomy and transanal minimally invasive surgery. Methods of making the simulated tissue structures are also provided.

(51) **Int. Cl.**
G09B 23/28 (2006.01)
C08L 33/26 (2006.01)

(Continued)

(52) **U.S. Cl.**
CPC **C08L 33/26** (2013.01); **B29C 39/003** (2013.01); **C08J 5/122** (2013.01); **G09B 23/30** (2013.01);

(Continued)

20 Claims, 4 Drawing Sheets

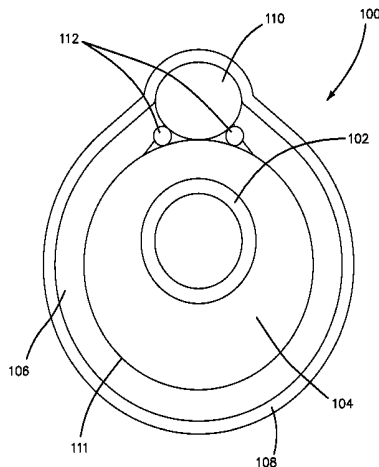

Related U.S. Application Data

(60) Provisional application No. 62/257,877, filed on Nov. 20, 2015, provisional application No. 62/161,322, filed on May 14, 2015.

(51) **Int. Cl.**
C08J 5/12 (2006.01)
G09B 23/30 (2006.01)
B29C 39/00 (2006.01)
B29K 33/00 (2006.01)
A61B 18/12 (2006.01)

(52) **U.S. Cl.**
 CPC *A61B 18/12* (2013.01); *B29K 2005/00* (2013.01); *B29K 2033/26* (2013.01); *C08J 2333/26* (2013.01); *C08J 2405/04* (2013.01)

(56) **References Cited**

U.S. PATENT DOCUMENTS

2,284,888	A	6/1942	Arneil, Jr.	5,769,640	A	6/1998	Jacobus et al.
2,324,702	A	7/1943	Hoffman et al.	5,775,916	A	7/1998	Cooper et al.
2,345,489	A	3/1944	Lord	5,785,531	A	7/1998	Leung
2,495,568	A	1/1950	Coel	5,800,178	A	9/1998	Gillio
3,766,666	A	10/1973	Stroop	5,803,746	A	9/1998	Barrie et al.
3,775,865	A	12/1973	Rowan	5,807,378	A	9/1998	Jensen et al.
3,789,518	A	2/1974	Chase	5,810,880	A	9/1998	Jensen et al.
3,921,311	A	11/1975	Beasley et al.	5,814,038	A	9/1998	Jensen et al.
3,991,490	A	11/1976	Markman	5,850,033	A	12/1998	Mirzebasov et al.
4,001,951	A	1/1977	Fasse	5,855,583	A	1/1999	Wang et al.
4,001,952	A	1/1977	Kleppinger	5,873,732	A	2/1999	Hasson
4,321,047	A	3/1982	Landis	5,873,863	A	2/1999	Komlosi
4,323,350	A	4/1982	Bowden, Jr.	5,908,302	A	6/1999	Goldfarb
4,332,569	A	6/1982	Burbank	5,947,743	A	9/1999	Hasson
4,371,345	A	2/1983	Palmer et al.	5,951,301	A	9/1999	Younker
4,386,917	A	6/1983	Forrest	6,080,181	A	6/2000	Jensen et al.
4,459,113	A	7/1984	Boscaro Gatti et al.	6,083,008	A	7/2000	Yamada et al.
4,481,001	A	11/1984	Graham et al.	6,113,395	A	9/2000	Hon
4,596,528	A	6/1986	Lewis et al.	6,234,804	B1	5/2001	Yong
4,726,772	A	2/1988	Amplatz	6,271,278	B1	8/2001	Park et al.
4,737,109	A	4/1988	Abramson	6,336,812	B1	1/2002	Cooper et al.
4,789,340	A	12/1988	Zikria	6,398,557	B1	6/2002	Hoballah
4,832,978	A	5/1989	Lesser	6,413,264	B1	7/2002	Jensen et al.
4,867,686	A	9/1989	Goldstein	6,474,993	B1	11/2002	Grund et al.
4,907,973	A	3/1990	Hon	6,485,308	B1	11/2002	Goldstein
4,938,696	A	7/1990	Foster et al.	6,488,507	B1	12/2002	Stoloff et al.
4,940,412	A	7/1990	Blumenthal	6,497,902	B1	12/2002	Ma
5,061,187	A	10/1991	Jerath	6,511,325	B1	1/2003	Lalka et al.
5,083,962	A	1/1992	Pracas	6,517,354	B1	2/2003	Levy
5,104,328	A	4/1992	Lounsbury	6,568,941	B1	5/2003	Goldstein
5,149,270	A	9/1992	McKeown	6,589,057	B1	7/2003	Keenan et al.
5,180,308	A	1/1993	Garito et al.	6,620,174	B2	9/2003	Jensen et al.
5,230,630	A	7/1993	Burgett	6,654,000	B2	11/2003	Rosenberg
5,273,435	A	12/1993	Jacobson	6,659,776	B1	12/2003	Aumann et al.
5,295,694	A	3/1994	Levin	6,773,263	B2	8/2004	Nicholls et al.
5,310,348	A	5/1994	Miller	6,780,016	B1	8/2004	Toly
5,318,448	A	6/1994	Garito et al.	6,817,973	B2	11/2004	Merril et al.
5,320,537	A	6/1994	Watson	6,820,025	B2	11/2004	Bachmann et al.
5,358,408	A	10/1994	Medina	6,854,976	B1	2/2005	Suhr
5,368,487	A	11/1994	Medina	6,857,878	B1	2/2005	Chosack et al.
5,380,207	A	1/1995	Siepsner	6,863,536	B1	3/2005	Fisher et al.
5,403,191	A	4/1995	Tuason	6,866,514	B2	3/2005	Von Roeschlaub et al.
5,425,644	A	6/1995	Szinicz	6,887,082	B2	5/2005	Shun
5,425,731	A	6/1995	Daniel et al.	6,929,481	B1	8/2005	Alexander et al.
5,472,345	A	12/1995	Eggert	6,939,138	B2	9/2005	Chosack et al.
5,518,406	A	5/1996	Waters	6,950,025	B1	9/2005	Nguyen
5,518,407	A	5/1996	Greenfield et al.	6,960,617	B2	11/2005	Omidian et al.
5,520,633	A	5/1996	Costin	6,997,719	B2	2/2006	Wellman et al.
5,541,304	A	7/1996	Thompson	7,008,232	B2	3/2006	Brassel
5,620,326	A	4/1997	Younker	7,018,327	B1	3/2006	Conti
5,720,742	A	2/1998	Zacharias	7,025,064	B2	4/2006	Wang et al.
5,722,836	A	3/1998	Younker	7,056,123	B2	6/2006	Gregorio et al.
5,727,948	A	3/1998	Jordan	7,080,984	B1	7/2006	Cohen
5,743,730	A	4/1998	Clester et al.	7,118,582	B1	10/2006	Wang et al.
5,762,458	A	6/1998	Wang et al.	7,255,565	B2	8/2007	Keegan
				7,269,532	B2	9/2007	David et al.
				7,272,766	B2	9/2007	Sakezles
				7,300,450	B2	11/2007	Vleugels et al.
				7,364,582	B2	4/2008	Lee
				7,404,716	B2	7/2008	Gregorio et al.
				7,419,376	B2	9/2008	Sarvazyan et al.
				7,427,199	B2	9/2008	Sakezles
				7,431,189	B2	10/2008	Shelton, IV et al.
				7,441,684	B2	10/2008	Shelton, IV et al.
				7,465,168	B2	12/2008	Allen et al.
				7,467,075	B2	12/2008	Humphries et al.
				7,544,062	B1	6/2009	Hauschild et al.
				7,549,866	B2	6/2009	Cohen et al.
				7,553,159	B1	6/2009	Arnal et al.
				7,575,434	B2	8/2009	Palakodeti
				7,594,815	B2	9/2009	Toly
				7,621,749	B2	11/2009	Munday
				7,646,901	B2	1/2010	Murphy et al.
				7,648,367	B1	1/2010	Makower et al.
				7,648,513	B2	1/2010	Green et al.
				7,651,332	B2	1/2010	Dupuis et al.
				7,677,897	B2	3/2010	Sakezles
				7,775,916	B1	8/2010	Mahoney
				7,780,451	B2	8/2010	Willobee et al.

(56)

References Cited

U.S. PATENT DOCUMENTS

7,802,990 B2	9/2010	Korndorffer et al.	8,801,438 B2	8/2014	Sakezles
7,803,151 B2	9/2010	Whitman	8,807,414 B2	8/2014	Ross et al.
7,806,696 B2	10/2010	Alexander et al.	8,808,004 B2	8/2014	Misawa et al.
7,819,799 B2	10/2010	Merril et al.	8,808,311 B2	8/2014	Heinrich et al.
7,833,018 B2	11/2010	Alexander et al.	8,814,573 B2	8/2014	Nguyen
7,837,473 B2	11/2010	Koh	8,827,988 B2	9/2014	Belson et al.
7,850,454 B2	12/2010	Toly	8,840,628 B2	9/2014	Green et al.
7,850,456 B2	12/2010	Chosack et al.	8,870,576 B2	10/2014	Millon et al.
7,854,612 B2	12/2010	Frassica et al.	8,888,498 B2	11/2014	Bisailon et al.
7,857,626 B2	12/2010	Toly	8,893,946 B2	11/2014	Boudreaux et al.
7,866,983 B2	1/2011	Hemphill et al.	8,911,238 B2	12/2014	Forsythe
7,931,470 B2	4/2011	Alexander et al.	8,915,742 B2	12/2014	Hendrickson et al.
7,931,471 B2	4/2011	Senagore et al.	8,945,095 B2	2/2015	Blumenkranz et al.
7,988,992 B2	8/2011	Omidian et al.	8,961,190 B2	2/2015	Hart et al.
7,993,140 B2	8/2011	Sakezles	8,966,954 B2	3/2015	Ni et al.
7,997,903 B2	8/2011	Hasson et al.	8,968,003 B2	3/2015	Hendrickson et al.
8,007,281 B2	8/2011	Toly	9,008,989 B2	4/2015	Wilson et al.
8,007,282 B2	8/2011	Gregorio et al.	9,017,080 B1	4/2015	Placik
8,016,818 B2	9/2011	Ellis et al.	9,026,247 B2	5/2015	White
8,017,107 B2	9/2011	Thomas et al.	9,050,201 B2	6/2015	Egilsson et al.
8,021,162 B2	9/2011	Sui	9,056,126 B2	6/2015	Hersel et al.
8,048,088 B2	11/2011	Green et al.	9,070,306 B2	6/2015	Rappel et al.
8,083,691 B2	12/2011	Goldenberg et al.	9,087,458 B2	7/2015	Shim et al.
8,116,847 B2	2/2012	Gattani et al.	9,096,744 B2	8/2015	Wan et al.
8,137,110 B2	3/2012	Sakezles	9,117,377 B2	8/2015	Shim et al.
8,157,145 B2	4/2012	Shelton, IV et al.	9,119,572 B2	9/2015	Gorek et al.
8,197,464 B2	6/2012	Kreuer et al.	9,123,261 B2	9/2015	Lowe
8,205,779 B2	6/2012	Ma et al.	9,129,054 B2	9/2015	Nawana et al.
8,221,129 B2	7/2012	Parry et al.	9,196,176 B2	11/2015	Hager et al.
8,297,982 B2	10/2012	Park et al.	9,226,799 B2	1/2016	Lightcap et al.
8,308,817 B2	11/2012	Egilsson et al.	9,257,055 B2	2/2016	Endo et al.
8,323,028 B2	12/2012	Matanhelia	9,265,587 B2	2/2016	Vancamberg et al.
8,323,029 B2	12/2012	Toly	9,295,468 B2	3/2016	Heinrich et al.
8,328,560 B2	12/2012	Niblock et al.	9,351,714 B2	5/2016	Ross et al.
8,342,851 B1	1/2013	Speeg et al.	9,336,694 B2	6/2016	Shim et al.
8,403,674 B2	3/2013	Feygin et al.	9,358,682 B2	6/2016	Ruiz Morales
8,403,675 B2	3/2013	Stoianovici et al.	9,364,224 B2	6/2016	Nicholas et al.
8,403,676 B2	3/2013	Frassica et al.	9,364,279 B2	6/2016	Houser et al.
8,408,920 B2	4/2013	Speller	9,370,361 B2	6/2016	Viola et al.
8,425,234 B2	4/2013	Sakezles	9,373,270 B2	6/2016	Miyazaki
8,439,687 B1	5/2013	Morriss et al.	9,387,276 B2	7/2016	Sun et al.
8,442,621 B2	5/2013	Gorek et al.	9,427,496 B2	8/2016	Sun et al.
8,454,368 B2	6/2013	Ault et al.	9,439,649 B2	9/2016	Shelton, IV et al.
8,459,094 B2	6/2013	Yanni	9,439,733 B2	9/2016	Ha et al.
8,459,520 B2	6/2013	Giordano et al.	9,449,532 B2	9/2016	Black et al.
8,460,002 B2	6/2013	Wang et al.	9,468,438 B2	10/2016	Baber et al.
8,465,771 B2	6/2013	Wan et al.	2001/0019818 A1	9/2001	Yong
8,469,715 B2	6/2013	Ambrozio	2002/0168619 A1	11/2002	Provenza
8,469,716 B2	6/2013	Fedotov et al.	2003/0031993 A1	2/2003	Pugh
8,480,407 B2	7/2013	Campbell et al.	2003/0091967 A1	5/2003	Chosack et al.
8,480,408 B2	7/2013	Ishii et al.	2003/0176770 A1	9/2003	Merril et al.
8,491,309 B2	7/2013	Parry et al.	2004/0005423 A1	1/2004	Dalton et al.
8,500,753 B2	8/2013	Green et al.	2004/0248072 A1	12/2004	Gray et al.
8,512,044 B2	8/2013	Sakezles	2005/0008997 A1	1/2005	Herman
8,517,243 B2	8/2013	Giordano et al.	2005/0026125 A1	2/2005	Toly
8,521,252 B2	8/2013	Diez	2005/0084833 A1	4/2005	Lacey et al.
8,535,062 B2	9/2013	Nguyen	2005/0131390 A1	6/2005	Heinrich et al.
8,544,711 B2	10/2013	Ma et al.	2005/0142525 A1	6/2005	Cotin et al.
8,556,635 B2	10/2013	Toly	2005/0192595 A1	9/2005	Green et al.
8,608,483 B2	12/2013	Trotta et al.	2005/0196739 A1	9/2005	Moriyama
8,613,621 B2	12/2013	Henderickson et al.	2005/0196740 A1	9/2005	Moriyama
8,636,520 B2	1/2014	Iwasaki et al.	2005/0214727 A1	9/2005	Stoianovici et al.
D699,297 S	2/2014	Bahsooun et al.	2006/0046235 A1	3/2006	Alexander et al.
8,641,423 B2	2/2014	Gumkowski	2006/0252019 A1	11/2006	Burkitt et al.
8,647,125 B2	2/2014	Johns et al.	2006/0275741 A1	12/2006	Chewning et al.
8,678,831 B2	3/2014	Trotta et al.	2007/0074584 A1	4/2007	Talarico et al.
8,679,279 B2	3/2014	Thompson et al.	2007/0077544 A1	4/2007	Lemperle et al.
8,690,580 B2	4/2014	Paronen	2007/0078484 A1	4/2007	Talarico et al.
8,696,363 B2	4/2014	Gray et al.	2007/0148626 A1	6/2007	Ikeda
8,708,213 B2	4/2014	Shelton, IV et al.	2007/0166682 A1	7/2007	Yarin et al.
8,708,707 B2	4/2014	Hendrickson et al.	2007/0197895 A1	8/2007	Nycz et al.
8,764,449 B2	7/2014	Rios et al.	2007/0225734 A1	9/2007	Bell et al.
8,764,452 B2	7/2014	Pravong et al.	2007/0275359 A1	11/2007	Rotnes et al.
8,800,839 B2	8/2014	Beetel	2008/0032272 A1	2/2008	Palakodeti
8,801,437 B2	8/2014	Mousques	2008/0032273 A1	2/2008	Macnamara et al.
			2008/0052034 A1	2/2008	David et al.
			2008/0064017 A1	3/2008	Grundmeyer, III
			2008/0076101 A1	3/2008	Hyde et al.
			2008/0097501 A1	4/2008	Blier

(56)

References Cited

U.S. PATENT DOCUMENTS

2008/0108869	A1	5/2008	Sanders et al.	2013/0218166	A1	8/2013	Elmore
2008/0187895	A1	8/2008	Sakezles	2013/0224709	A1	8/2013	Riojas et al.
2008/0188948	A1	8/2008	Flatt	2013/0245681	A1	9/2013	Strahenz et al.
2008/0299529	A1	12/2008	Schaller	2013/0253480	A1	9/2013	Kimball et al.
2008/0317818	A1	12/2008	Griffith et al.	2013/0267876	A1	10/2013	Leckenby et al.
2009/0068627	A1	3/2009	Toly	2013/0282038	A1	10/2013	Dannaher et al.
2009/0142739	A1	6/2009	Wang et al.	2013/0288216	A1	10/2013	Parry, Jr. et al.
2009/0142741	A1	6/2009	Ault et al.	2013/0302771	A1	11/2013	Alderete
2009/0143642	A1	6/2009	Takahashi et al.	2013/0324991	A1	12/2013	Clem et al.
2009/0176196	A1	7/2009	Niblock et al.	2013/0324999	A1	12/2013	Price et al.
2009/0187079	A1	7/2009	Albrecht et al.	2014/0011172	A1	1/2014	Lowe
2009/0246747	A1	10/2009	Buckman, Jr.	2014/0017651	A1	1/2014	Sugimoto et al.
2009/0298034	A1	12/2009	Parry et al.	2014/0030682	A1	1/2014	Thilenius
2010/0047752	A1	2/2010	Chan et al.	2014/0038151	A1	2/2014	Hart
2010/0094312	A1	4/2010	Ruiz Morales et al.	2014/0051049	A1	2/2014	Jarc et al.
2010/0099067	A1	4/2010	Agro	2014/0072941	A1	3/2014	Hendrickson et al.
2010/0167248	A1	7/2010	Ryan	2014/0087345	A1	3/2014	Breslin et al.
2010/0167249	A1	7/2010	Ryan	2014/0087346	A1	3/2014	Breslin et al.
2010/0167250	A1	7/2010	Ryan et al.	2014/0087347	A1	3/2014	Tracy et al.
2010/0167253	A1	7/2010	Ryan et al.	2014/0087348	A1	3/2014	Tracy et al.
2010/0167254	A1	7/2010	Nguyen	2014/0088413	A1	3/2014	Von Bucsh et al.
2010/0196867	A1	8/2010	Geerligs et al.	2014/0093852	A1	4/2014	Poulsen et al.
2010/0204713	A1	8/2010	Ruiz Morales	2014/0093854	A1	4/2014	Poulsen et al.
2010/0209899	A1	8/2010	Park	2014/0099858	A1	4/2014	Hernandez
2010/0258611	A1	10/2010	Smith et al.	2014/0106328	A1	4/2014	Loor
2010/0273136	A1	10/2010	Kandasami et al.	2014/0107471	A1	4/2014	Haider et al.
2010/0279263	A1	11/2010	Duryea	2014/0156002	A1	6/2014	Thompson et al.
2010/0285094	A1	11/2010	Gupta	2014/0162016	A1	6/2014	Matsui et al.
2010/0324541	A1	12/2010	Whitman	2014/0170623	A1	6/2014	Jarstad et al.
2010/0330545	A1*	12/2010	Tian A61B 17/00 434/267	2014/0186809	A1	7/2014	Hendrickson et al.
2011/0046637	A1	2/2011	Patel et al.	2014/0187855	A1	7/2014	Nagale et al.
2011/0046659	A1	2/2011	Ramstein et al.	2014/0200561	A1	7/2014	Ingmanson et al.
2011/0087238	A1	4/2011	Wang et al.	2014/0212861	A1	7/2014	Romano
2011/0091855	A1	4/2011	Miyazaki	2014/0220527	A1	8/2014	Li et al.
2011/0137337	A1	6/2011	van den Dool et al.	2014/0220530	A1	8/2014	Merkle et al.
2011/0200976	A1	8/2011	Hou et al.	2014/0220532	A1	8/2014	Ghez et al.
2011/0207104	A1	8/2011	Trotta	2014/0242564	A1	8/2014	Pravong et al.
2011/0218550	A1	9/2011	Ma	2014/0246479	A1	9/2014	Baber et al.
2011/0244436	A1	10/2011	Campo	2014/0248596	A1	9/2014	Hart et al.
2011/0269109	A2	11/2011	Miyazaki	2014/0263538	A1	9/2014	Leimbach et al.
2011/0281251	A1	11/2011	Mousques	2014/0272878	A1	9/2014	Shim et al.
2011/0301620	A1	12/2011	Di Betta et al.	2014/0272879	A1	9/2014	Shim et al.
2012/0015337	A1	1/2012	Hendrickson et al.	2014/0275795	A1	9/2014	Little et al.
2012/0015339	A1	1/2012	Hendrickson et al.	2014/0275981	A1	9/2014	Selover et al.
2012/0016362	A1	1/2012	Heinrich et al.	2014/0277017	A1	9/2014	Leimbach et al.
2012/0028231	A1	2/2012	Misawa et al.	2014/0303643	A1	10/2014	Ha et al.
2012/0045743	A1	2/2012	Misawa et al.	2014/0303646	A1	10/2014	Morgan et al.
2012/0065632	A1	3/2012	Shaddock	2014/0303660	A1	10/2014	Boyden et al.
2012/0082970	A1	4/2012	Pravong et al.	2014/0308643	A1	10/2014	Trotta et al.
2012/0100217	A1	4/2012	Green et al.	2014/0342334	A1	11/2014	Black et al.
2012/0115117	A1	5/2012	Marshall	2014/0349266	A1	11/2014	Choi
2012/0115118	A1	5/2012	Marshall	2014/0350530	A1	11/2014	Ross et al.
2012/0116391	A1	5/2012	Houser et al.	2014/0357977	A1	12/2014	Zhou
2012/0148994	A1	6/2012	Hori et al.	2014/0370477	A1	12/2014	Black et al.
2012/0164616	A1	6/2012	Endo et al.	2014/0371761	A1	12/2014	Juanpera
2012/0165866	A1	6/2012	Kaiser et al.	2014/0378995	A1	12/2014	Kumar et al.
2012/0172873	A1	7/2012	Artale et al.	2015/0031008	A1	1/2015	Black et al.
2012/0179072	A1	7/2012	Kegreiss	2015/0037773	A1	2/2015	Quirarte Catano
2012/0202180	A1	8/2012	Stock et al.	2015/0038613	A1	2/2015	Sun et al.
2012/0264096	A1	10/2012	Taylor et al.	2015/0076207	A1	3/2015	Boudreaux et al.
2012/0264097	A1	10/2012	Newcott et al.	2015/0086955	A1	3/2015	Poniatowski et al.
2012/0282583	A1	11/2012	Thaler et al.	2015/0132732	A1	5/2015	Hart et al.
2012/0282584	A1	11/2012	Millon et al.	2015/0132733	A1	5/2015	Garvik et al.
2012/0283707	A1	11/2012	Giordano et al.	2015/0135832	A1	5/2015	Blumenkranz et al.
2012/0288839	A1	11/2012	Crabtree	2015/0148660	A1	5/2015	Weiss et al.
2012/0308977	A1	12/2012	Tortola	2015/0164598	A1	6/2015	Blumenkranz et al.
2013/0087597	A1	4/2013	Shelton, IV et al.	2015/0187229	A1	7/2015	Wachli et al.
2013/0101973	A1	4/2013	Hoke et al.	2015/0194075	A1	7/2015	Rappel et al.
2013/0105552	A1	5/2013	Weir et al.	2015/0202299	A1	7/2015	Burdick et al.
2013/0116668	A1	5/2013	Shelton, IV et al.	2015/0209035	A1	7/2015	Zemlock
2013/0157240	A1	6/2013	Hart et al.	2015/0209059	A1	7/2015	Trees et al.
2013/0171288	A1	7/2013	Harders	2015/0209573	A1	7/2015	Hibner et al.
2013/0177890	A1	7/2013	Sakezles	2015/0228206	A1	8/2015	Shim et al.
2013/0192741	A1	8/2013	Trotta et al.	2015/0262511	A1	9/2015	Lin et al.
				2015/0265431	A1	9/2015	Egilsson et al.
				2015/0272571	A1	10/2015	Leimbach et al.
				2015/0272574	A1	10/2015	Leimbach et al.
				2015/0272580	A1	10/2015	Leimbach et al.
				2015/0272581	A1	10/2015	Leimbach et al.

(56) **References Cited**

U.S. PATENT DOCUMENTS

2015/0272583	A1	10/2015	Leimbach et al.	
2015/0272604	A1	10/2015	Chowaniec et al.	
2015/0332609	A1	11/2015	Alexander	
2015/0358426	A1	12/2015	Kimball et al.	
2015/0371560	A1	12/2015	Lowe	
2015/0374378	A1	12/2015	Giordano et al.	
2015/0374449	A1	12/2015	Chowaniec et al.	
2016/0000437	A1	1/2016	Giordano et al.	
2016/0022374	A1	1/2016	Haider et al.	
2016/0027341	A1*	1/2016	Kerins	G09B 23/34 434/270
2016/0030240	A1	2/2016	Gonenc et al.	
2016/0031091	A1	2/2016	Popovic et al.	
2016/0058534	A1	3/2016	Derwin et al.	
2016/0066909	A1	3/2016	Baber et al.	
2016/0070436	A1	3/2016	Thomas et al.	
2016/0073928	A1	3/2016	Soper et al.	
2016/0074103	A1	3/2016	Sartor	
2016/0098933	A1	4/2016	Reiley et al.	
2016/0104394	A1	4/2016	Miyazaki	
2016/0117956	A1	4/2016	Larsson et al.	
2016/0133158	A1	5/2016	Sui et al.	
2016/0140876	A1	5/2016	Jabbour et al.	
2016/0194378	A1	7/2016	Cass et al.	
2016/0199059	A1	7/2016	Shelton, IV et al.	
2016/0220150	A1	8/2016	Sharonov	
2016/0220314	A1	8/2016	Huelman et al.	
2016/0225288	A1	8/2016	East et al.	
2016/0232819	A1	8/2016	Hofstetter et al.	
2016/0235494	A1	8/2016	Shelton, IV et al.	
2016/0256187	A1	9/2016	Shelton, IV et al.	
2016/0256229	A1	9/2016	Morgan et al.	
2016/0262736	A1	9/2016	Ross et al.	
2016/0262745	A1	9/2016	Morgan et al.	
2016/0293055	A1	10/2016	Hofstetter	
2016/0296144	A1	10/2016	Gaddam et al.	

FOREIGN PATENT DOCUMENTS

CN	2909427	Y	6/2007
CN	101313842	A	12/2008
CN	101528780	A	9/2009
CN	201364679	Y	12/2009
CN	201955979	U	8/2011
CN	102458496	A	5/2012
CN	202443680	U	9/2012
CN	202563792	U	11/2012
CN	202601055	U	12/2012
CN	202694651	U	1/2013
CN	103050040	A	4/2013
CN	203013103	U	6/2013
CN	203038549	U	7/2013
CN	203338651	U	12/2013
CN	203397593	U	1/2014
CN	203562128	U	4/2014
CN	102596275	B	6/2014
CN	103845757	A	6/2014
CN	103886797	A	6/2014
CN	103396562	B	7/2015
CN	105194740	A	12/2015
CN	105504166	A	4/2016
DE	41 05 892	A1	8/1992
DE	44 14 832	A1	11/1995
DE	19716341	A1	9/2000
EP	1 024 173	A1	8/2000
FR	2 691 826	A1	12/1993
FR	2 917 876	A1	12/2008
GB	2488994	A	9/2012
JP	10 211160	A	8/1998
JP	2001005378	A	1/2001
JP	2009236963	A	10/2009
JP	3162161	U	8/2010
JP	2013127496	A	6/2013
KR	101231565	B1	2/2013

MX	PA02004422	A	11/2003
MX	PA 02004422	A	11/2003
PT	106230		9/2013
WO	WO 1994/06109	A1	3/1994
WO	WO 1996/042076	A1	12/1996
WO	WO 1998/58358	A1	12/1998
WO	WO 1999/01074	A1	1/1999
WO	WO 2000/36577	A1	6/2000
WO	WO 2002/38039	A2	5/2002
WO	WO 2002/038039	A3	5/2002
WO	WO 2004/032095	A1	4/2004
WO	WO 2004/082486	A1	9/2004
WO	WO 2005/071639	A1	8/2005
WO	WO 2006/083963	A2	8/2006
WO	WO 2007/068360	A1	6/2007
WO	WO 2008/021720	A2	2/2008
WO	WO 2009/000939	A1	12/2008
WO	WO 2010/094730	A1	8/2010
WO	WO 2011/035410	A1	3/2011
WO	WO 2011/046606	A1	4/2011
WO	WO 2011/151304	A1	12/2011
WO	WO 2012/149606	A1	11/2012
WO	WO 2012/168287	A1	12/2012
WO	WO 2012/175993	A1	12/2012
WO	WO 2013/048978	A1	4/2013
WO	WO 2013/103956	A1	7/2013
WO	WO 2014/022815	A1	2/2014
WO	WO 2014/093669	A1	6/2014
WO	WO 2015/148817	A1	10/2015
WO	WO 2016/138528	A1	9/2016
WO	WO 2016/198238	A1	12/2016
WO	WO 2017/031214	A1	2/2017
WO	WO 2017/042301	A1	3/2017

OTHER PUBLICATIONS

The International Bureau of WIPO, International Preliminary Report on Patentability for International Application No. PCT/US2016/034591, entitled "Surgical Training Model for Laparoscopic Procedures," dated Dec. 7, 2017, 2017, 14 pgs.

The International Bureau of WIPO, International Preliminary Report on Patentability for International Application No. PCT/US2016/036664, entitled "Hysterectomy Model," dated Dec. 21, 2017, 10 pgs.

Society of Laparoendoscopic Surgeons, "Future Technology Session: The Edge of Innovation in Surgery, Space, and Business," <http://www.laparoscopytoday.com/endourology/page/2/>, Figure 1B: http://laparoscopy.blogs.com/laparoscopy_today/images/6-1/6-1VlaovicPicB.jpg, Sep. 5-8, 2007, 10 pgs.

European Patent Office, International Search Report for International Application No. PCT/US2011/053859 A3, dated Apr. 5, 2012, entitled "Portable Laparoscopic Trainer," 8 pgs.

European Patent Office, The International Search Report and Written Opinion for International Application No. PCT/US2012/60997, dated Mar. 7, 2013, entitled "Simulated Tissue Structure for Surgical Training," 8 pgs.

European Patent Office, The International Search Report and Written Opinion for International Application No. PCT/US2012/070971, entitled "Advanced Surgical Simulation," dated Mar. 18, 2013, 10 pgs.

Human Patient Simulator, Medical Education Technologies, Inc., <http://www.meti.com> (1999) all, printed Apr. 12, 2013, 24 pgs.

The International Bureau of WIPO, International Preliminary Report on Patentability and Written Opinion for International Application No. PCT/US2011/053859, titled "Portable Laparoscopic Trainer" dated Apr. 2, 2013, 9 pgs.

European Patent Office, The International Search Report and Written Opinion for International Application No. PCT/US2013/062363, entitled "Surgical Training Model for Laparoscopic Procedures," dated Jan. 22, 2014, 11 pgs.

European Patent Office, The International Search Report and Written Opinion for International Application No. PCT/US2013/061949, entitled "Surgical Training Model for Laparoscopic Procedures," dated Feb. 17, 2014, 7 pgs.

(56)

References Cited

OTHER PUBLICATIONS

- Anonymous: Realsim Systems—LTS2000, Sep. 4, 2005, pp. 1-2, XP055096193, Retrieved from the Internet: URL: <https://web.archive.org/web/2005090403/3030/http://www.realsimsystems.com/exersizes.htm> (retrieved on Jan. 14, 2014).
- European Patent Office, The International Search Report and Written Opinion for International Application No. PCT/US2013/062269, entitled “Surgical Training Model for Transluminal Procedures,” dated Feb. 17, 2014, 8 pgs.
- European Patent Office, The International Search Report and Written Opinion for International Application No. PCT/US2013/061557, entitled “Surgical Training Model for Laparoscopic Procedures,” dated Feb. 10, 2014, 9 pgs.
- European Patent Office, The International Search Report and Written Opinion for International Application No. PCT/US2013/061728, entitled “Surgical Training Model for Laparoscopic Procedures,” dated Oct. 18, 2013, 9 pgs.
- Limbs and Things, EP Guildford MATTU Hernia Trainer, <http://limbsandthings.com/us/products/tep-guildford-mattu-hernia-trainer/>, printed May 29, 2014, 11 pgs.
- Simulab, Hernia Model, http://www.simulab.com/product/surgery/open/hernia_model, printed May 29, 2014, 4 pgs.
- McGill Laparoscopic Inguinal Hernia Simulator, Novel Low-Cost Simulator for Laparoscopic Inguinal Hernia Repair, Feb. 8, 2011, 1 pg.
- University of Wisconsin-Madison Biomedical Engineering, Inguinal Hernia Model, http://bmedesign.engr.wisc.edu/projects/s10/hernia_model/, printed May 29, 2014, 62 pgs.
- The International Bureau of WIPO, International Preliminary Report on Patentability for International Application No. PCT/US2012/070971, titled “Advanced Surgical Simulation” dated Jun. 24, 2014, 7 pgs.
- European Patent Office, The International Search Report and Written Opinion of the International Searching Authority for International Application No. PCT/US2014/038195 titled “Hernia Model”, dated Oct. 15, 2014, 20 pgs.
- European Patent Office, The International Search Report and Written Opinion of the International Searching Authority for International Application No. PCT/US2014/048027 titled “First Entry Model”, dated Oct. 17, 2014, 10 pgs.
- The International Bureau of WIPO, International Preliminary Report on Patentability for International Application No. PCT/US2012/060997, titled “Simulated Tissue Structure for Surgical Training” dated Apr. 22, 2014, 6 pgs.
- European Patent Office, The International Search Report and Written Opinion for International Application No. PCT/US2014/019840, entitled “Advanced Surgical Simulation Constructions and Methods,” dated Jul. 4, 2014, 8 pgs.
- Kurashima Y et al, “A tool for training and evaluation of Laparoscopic inguinal hernia repair; the Global Operative Assessment of Laparoscopic Skills-Groin Hernia” American Journal of Surgery, Paul Hoeber, New York, NY, US vol. 201, No. 1, Jan. 1, 2011, pp. 54-61 XP027558745.
- European Patent Office, The International Search Report and Written Opinion for International Application No. PCT/US2014/042998, title: Gallbladder Model, dated Jan. 7, 2015, 20 pgs.
- The International Bureau of WIPO, International Preliminary Report on Patentability, for PCT application No. PCT/US2013/053497, titled, Simulated Stapling and Energy Based Ligation for Surgical Training, dated Feb. 12, 2015, 6 pgs.
- The International Bureau of WIPO, International Preliminary Report on Patentability for International Application No. PCT/US2013/062363, titled Surgical Training Model for Laparoscopic Procedures, dated Apr. 9, 2015, 9 pgs.
- The International Bureau of WIPO, International Preliminary Report on Patentability for International Application No. PCT/US2013/062269, titled Surgical Training Model for Laparoscopic Procedures, dated Apr. 9, 2015, 6 pgs.
- The International Bureau of WIPO, International Preliminary Report on Patentability for International Application No. PCT/US2013/061557, titled Surgical Training Model for Laparoscopic Procedures, dated Apr. 9, 2015, 6 pgs.
- The International Bureau of WIPO, International Preliminary Report on Patentability for International Application No. PCT/US2013/061728, titled Surgical Training Model for Laparoscopic Procedures, dated Apr. 9, 2015, 7 pgs.
- The International Bureau of WIPO, International Preliminary Report on Patentability for International Application No. PCT/US2013/061949, titled Surgical Training Model for Laparoscopic Procedures, dated Apr. 9, 2015, 6 pgs.
- The International Bureau of WIPO, International Preliminary Report on Patentability for International Application No. PCT/US2014/019840, titled “Simulated Tissue Structure for Surgical Training” dated Sep. 11, 2015, 8 pgs.
- European Patent Office, The International Search Report and Written Opinion for International Application No. PCT/US2015/020574, titled “Advanced First Entry Model for Surgical Simulation,” dated Jun. 1, 2015, 12 pgs.
- European Patent Office, The International Search Report and Written Opinion for International Application No. PCT/US2015/022774, entitled “Simulated Dissectible Tissue,” dated Jun. 11, 2015, 13 pgs.
- Anonymous: Silicone rubber-from Wikipedia, the free encyclopedia, pp. 1-6, XP055192375, Retrieved from the Internet: URL: http://en.wikipedia.org/w/index.php?title=Silicone_rubber&oldid=596456058 (retrieved on May 29, 2015).
- Lamouche, et al., “Review of tissue simulating phantoms with controllable optical, mechanical and structural properties for use in optical coherence tomography,” Biomedical Optics Express, Jun. 1, 2012, 18 pgs., vol. 3, No. 6.
- The International Bureau of WIPO, International Preliminary Report on Patentability for International Application No. PCT/US2014/038195, titled “Hernia Model,” dated Nov. 26, 2015, 16 pgs.
- The International Bureau of WIPO, International Preliminary Report on Patentability for International Application No. PCT/US2014/042998, titled “Gallbladder Model,” dated Dec. 30, 2015, 15 pgs.
- European Patent Office, International Search Report and Written Opinion for International Application No. PCT/US2013/053497, titled “Simulated Stapling and Energy Based Ligation for Surgical Training,” dated Nov. 5, 2013, 8 pgs.
- The International Bureau of WIPO, International Preliminary Report on Patentability for International Application No. PCT/US2014/048027, titled “First Entry Model,” dated Feb. 4, 2016, 8 pgs.
- European Patent Office, International Search Report and Written Opinion for International Application No. PCT/US2015/059668, titled “Simulated Tissue Models and Methods,” dated Apr. 26, 2016, 20 pgs.
- Australian Patent Office, Patent Examination Report No. 1 for Australian Application No. 2012358851, titled “Advanced Surgical Simulation,” dated May 26, 2016, 3 pgs.
- Miyazaki Enterprises, “Miya Model Pelvic Surgery Training Model and Video,” www.miyazakienterprises.com, printed Jul. 1, 2016, 1 pg.
- European Patent Office, International Search Report and Written Opinion for International Application No. PCT/US2016/032292 titled “Synthetic Tissue Structures for Electrosurgical Training and Simulation,” dated Jul. 14, 2016, 11 pgs.
- European Patent Office, International Search Report and Written Opinion for International Application No. PCT/US2016/018697 titled “Simulated Tissue Structures and Methods,” dated Jul. 14, 2016, 21 pgs.
- European Patent Office, International Search Report and Written Opinion for International Application No. PCT/US2016/034591, titled “Surgical Training Model for Laparoscopic Procedures,” dated Aug. 8, 2016, 18 pgs.
- 3D-MED Corporation, “Validated Training Course for Laparoscopic Skills,” http://www.3-dmed.com/sites/default/files/product-additional-product-spec/Validated%20Training%20Course/%20for%20Laparoscopic%20Skills.docx_3.pdf, printed Aug. 23, 2016, pp. 1-6.
- 3D-MED Corporation, “Loops and Wire #1,” 1, <https://www.3-dmed.com/product/loops-and-wire-1>, printed Aug. 23, 2016, 4 pgs.

(56)

References Cited

OTHER PUBLICATIONS

European Patent Office, The International Search Report and Written Opinion of the International Searching Authority for International Application No. PCT/US2016/036664 titled "Hysterectomy Model", dated Aug. 19, 2016, 15 pgs.

The International Bureau of WIPO, International Preliminary Report on Patentability for International Application No. PCT/US2015/020574, entitled "Advanced First Entry Model for Surgical Simulation," dated Sep. 22, 2016, 9 pgs.

European Patent Office, The International Search Report and Written Opinion of the International Searching Authority for International Application No. PCT/US2016/0043277 titled "Appendectomy Model", dated Oct. 4, 2016, 12 pgs.

The International Bureau of WIPO, International Preliminary Report on Patentability for International Application No. PCT/US2015/022774, titled "Simulated Dissectible Tissue," dated Oct. 6, 2016, 9 pgs.

European Patent Office, The International Search Report and Written Opinion of the International Searching Authority for International Application No. PCT/US2016/041852 titled "Simulated Dissectible Tissue", dated Oct. 13, 2016, 12 pgs.

Barrier, et al., "A Novel and Inexpensive Vaginal Hysterectomy Simulator," *Simulation in Healthcare: The Journal of the Society for Simulation in Healthcare*, vol. 7, No. 6, Dec. 1, 2012, pp. 374-379.

European Patent Office, Examination Report for European Application No. 14733949.3 titled "Gallbladder Model," dated Dec. 21, 2016, 6 pgs.

European Patent Office, The International Search Report and Written Opinion of the International Searching Authority for International Application No. PCT/US2016/062669 titled "Simulated Dissectible Tissue," dated Apr. 5, 2017, 19 pgs.

European Patent Office, The International Search Report and Written Opinion of the International Searching Authority for International Application No. PCT/US2017/020389 titled "Simulated Tissue Cartridge", dated May 24, 2017, 13 pgs.

The International Bureau of WIPO, International Preliminary Report on Patentability and Written Opinion for International Application No. PCT/US2015/059668, entitled "Simulated Tissue Models and Methods," dated May 26, 2017, 16 pgs.

The International Bureau of WIPO, International Preliminary Report on Patentability for International Application No. PCT/US2016/041852, entitled "Simulated Dissectible Tissue," dated Jan. 25, 2018, 12 pgs.

European Patent Office, Extended European Search Report for European Patent Application No. EP 17202365.7, titled "Gallbladder Model", dated Jan. 31, 2018, 8 pgs.

The International Bureau of WIPO, International Preliminary Report on Patentability for International Application No. PCT/US2016/043277, entitled "Appendectomy Model," dated Feb. 1, 2018, 9 pgs.

The International Bureau of WIPO, International Preliminary Report on Patentability for International Application No. PCT/US2016/018697, entitled "Simulated Tissue Structures and Methods," dated Aug. 31, 2017, 14 pgs.

European Patent Office, Invitation to Pay Additional Fees for International Application No. PCT/US2016/062669, titled "Simulated Dissectible Tissue", dated Feb. 10, 2017, 8 pgs.

European Patent Office, The International Search Report and Written Opinion of the International Searching Authority for International Application No. PCT/US2016/055148 titled "Hysterectomy Model", dated Feb. 28, 2017, 12 pgs.

The International Bureau of WIPO, International Preliminary Report on Patentability for International Application No. PCT/US2016/055148, entitled "Hysterectomy Model," dated Apr. 12, 2018, 12 pgs.

* cited by examiner

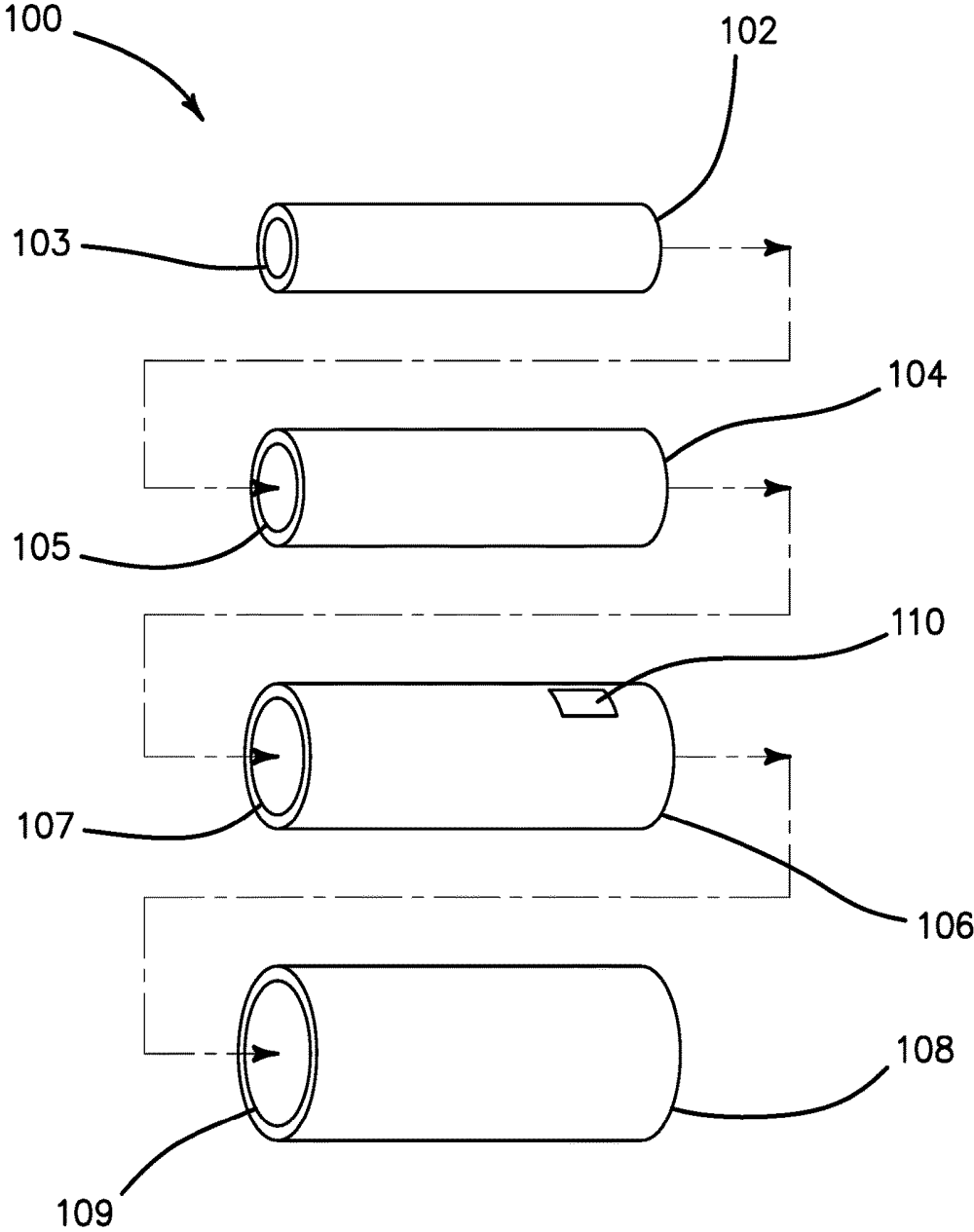

FIG. 1

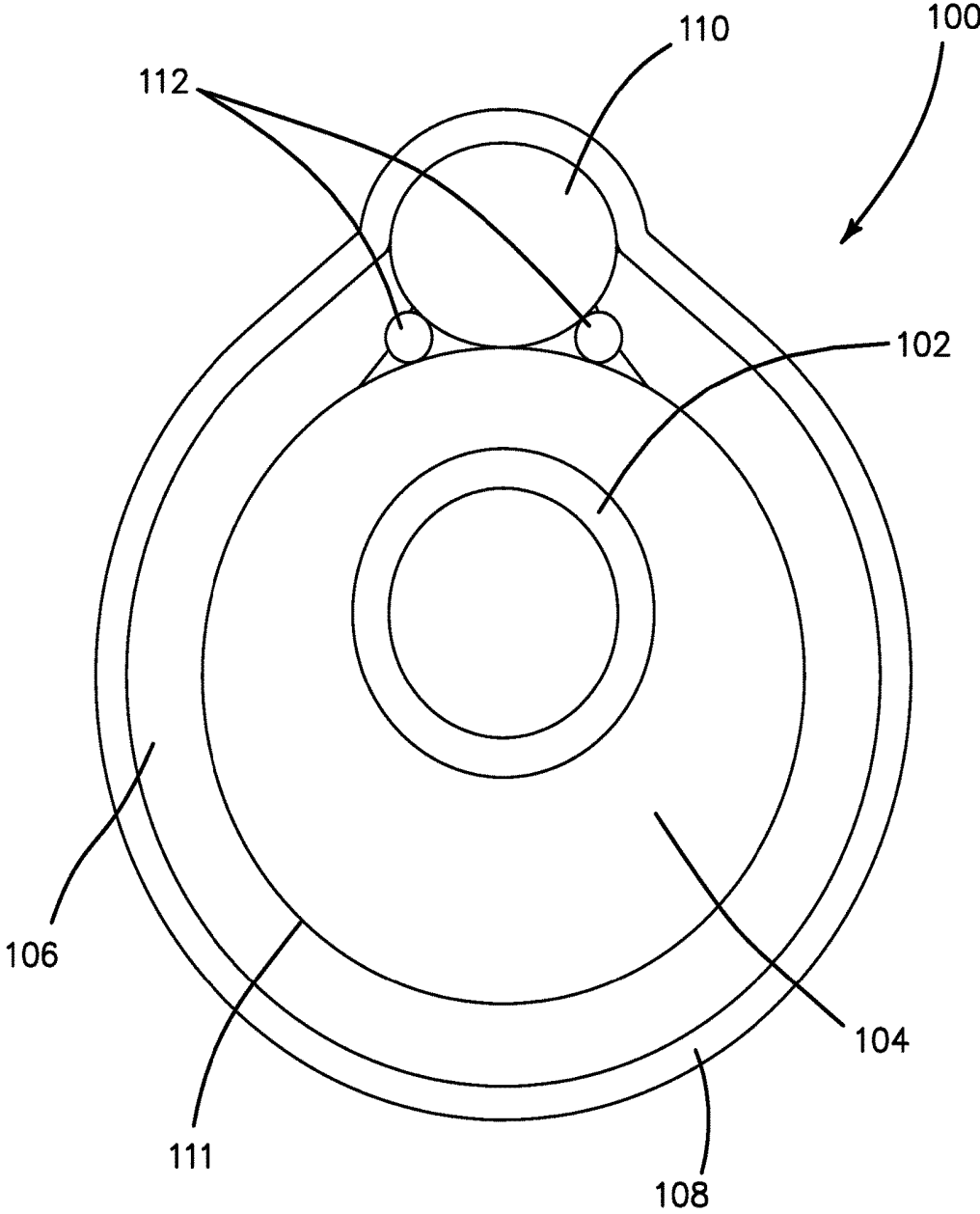
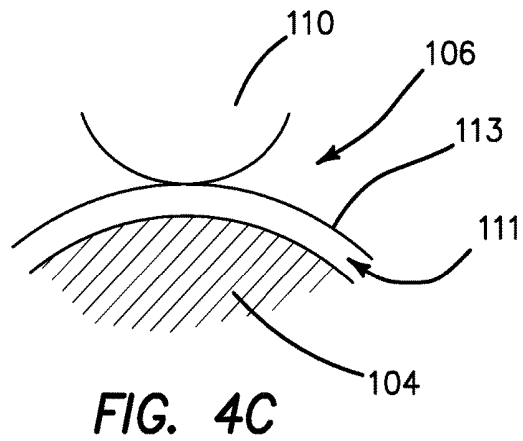
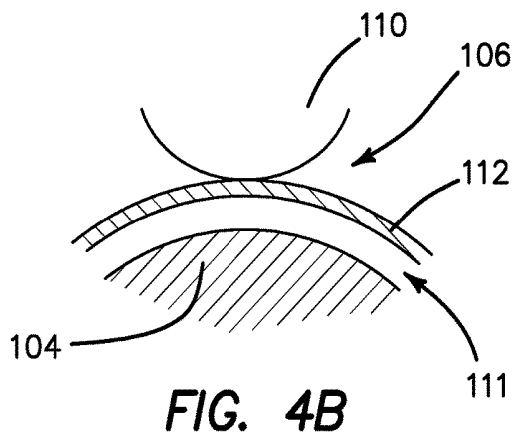
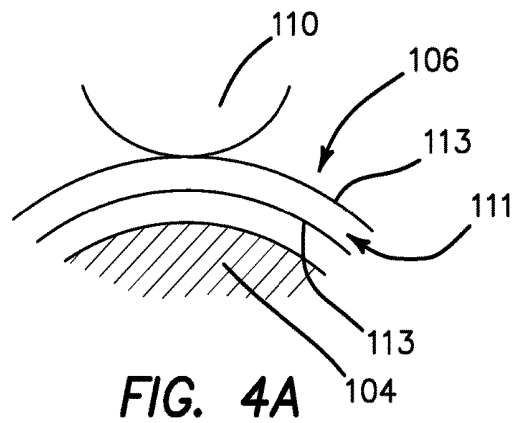
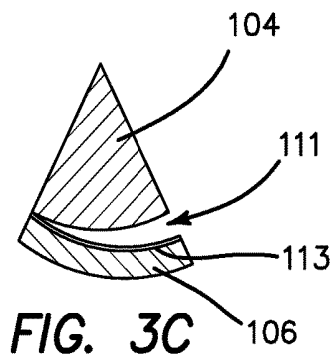
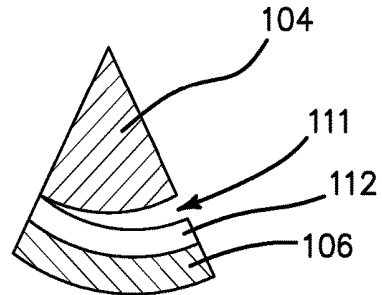
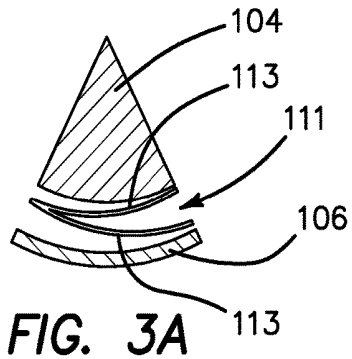

FIG. 2



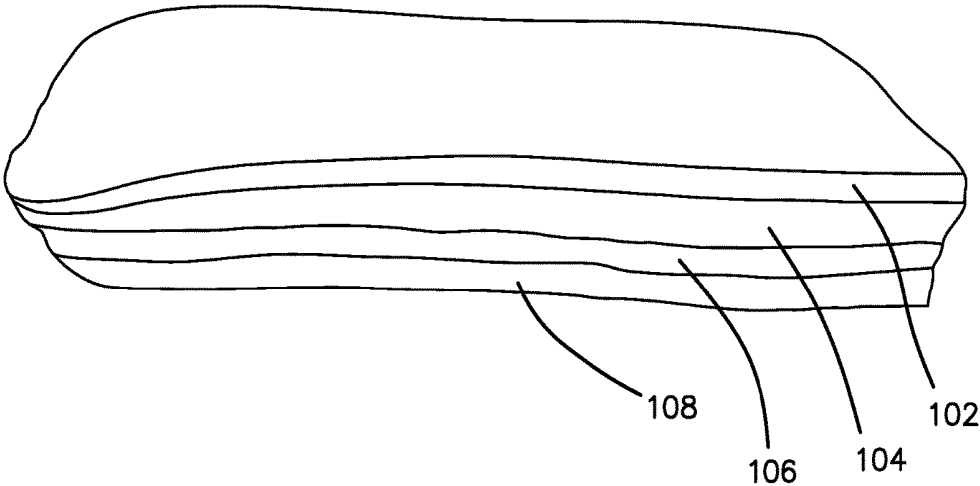

FIG. 5

SYNTHETIC TISSUE STRUCTURES FOR ELECTROSURGICAL TRAINING AND SIMULATION

CROSS-REFERENCE TO RELATED APPLICATIONS

This application is a continuation of International Patent Application No. PCT/US2016/032292 filed on May 13, 2016 entitled "Synthetic tissue structures for electrosurgical training and simulation" which claims priority to and benefit of U.S. Provisional Patent Application No. 62/161,322 filed on May 14, 2015 entitled "Synthetic tissue for electrosurgical training and simulation", and U.S. Provisional Patent Application No. 62/257,877 filed on Nov. 20, 2015 entitled "Synthetic tissue training for electrosurgical training and simulation" all of which are incorporated herein by reference in their entireties.

FIELD OF THE INVENTION

This application relates to synthetic tissue for practicing electrosurgical procedures and, in particular, to conductive synthetic tissue material made from a cross-linked hydrogel and methods of manufacturing such material and synthetic tissue models.

BACKGROUND OF THE INVENTION

Advances in technology have led to an increased use of energy devices in surgical procedures. There is a need for synthetic tissue that closely resembles the response of human tissue to electrosurgery. The synthetic tissue would be advantageous to surgeons and residents for training purposes. The synthetic tissue requires several characteristics to closely resemble human tissue including the ability to be cauterized, cut, and fused when manipulated with energy devices. Additionally, the tissue needs to emulate the mechanical properties of real tissue such as elasticity, toughness, suturability, tactility, color and texture. Furthermore, the material needs to be moldable into a structure that mimics various human organs or membranes for simulating human anatomy. The synthetic tissue may also need to be bondable to a variety of thermoplastics and silicones. The present invention addresses these needs.

SUMMARY OF THE INVENTION

According to one aspect of the invention, a surgical simulator for surgical training is provided. The surgical simulator includes a synthetic tissue structure formed at least in part of a hydrogel including an ionically cross-linked alginate network cross-linked with a covalently cross-linked acrylamide network. The synthetic tissue structure includes at least one of an artificial liver or artificial gallbladder. The at least one of the artificial liver or artificial gallbladder includes at least one lumen substantially formed of a hydrogel including an ionically cross-linked alginate network cross-linked with a covalently cross-linked acrylamide network.

According to another aspect of the invention, a surgical simulator for surgical training is provided. The surgical simulator includes a synthetic tissue structure substantially formed of a hydrogel including an ionically cross-linked alginate network cross-linked with a covalently cross-linked acrylamide network. The synthetic tissue structure includes a first layer formed of the hydrogel having a first ratio of

acrylamide to alginate by weight and a second layer formed of the hydrogel having a second ratio of acrylamide to alginate by weight. The second layer is adjacent to the first layer.

According to another aspect of the invention, a surgical simulator for surgical training is provided. The surgical simulator includes a simulated organ model. The simulated organ model includes a first tube having an outer surface and an inner surface defining a first lumen. The first tube is made of a hydrogel comprising a dual interpenetrated network of ionically cross-linked alginate and covalently cross-linked acrylamide having a first ratio of acrylamide to alginate. The simulated organ model includes a second tube having an outer surface and an inner surface defining a second lumen. The second tube is made of a hydrogel comprising a dual interpenetrated network of ionically cross-linked alginate and covalently cross-linked acrylamide having a second ratio of acrylamide to alginate. The first tube is coaxially located inside the second lumen such that the outer surface of the first tube is in contact with the inner surface of the second tube.

According to another aspect of the invention, a method of making a surgical simulator for the practice of electrosurgical techniques is provided. The method includes the steps of providing an acrylamide polymer, providing alginate polymer, providing water, mixing the water with the acrylamide and alginate to form a solution, adding ammonium persulfate to the solution, adding N,N-methylenebisacrylamide to the solution, adding calcium sulfate after the steps of adding ammonium persulfate and adding N,N-methylenebisacrylamide to the solution, casting the solution into a shape representative of an anatomical structure, and curing the solution to form a simulated electrosurgery model made of hydrogel for practicing and simulating electrosurgery.

According to another aspect of the invention, a method of making a surgical simulator for the practice of electrosurgical techniques is provided. The method includes the step of providing an uncured hydrogel including an ionically cross-linked alginate network cross-linked with a covalently cross-linked acrylamide network. The method includes the step of providing a polymer bag, pouring the uncured hydrogel into the polymer bag, sealing the polymer bag, curing the uncured hydrogel inside the polymer bag to form a cured hydrogel, and removing the cured hydrogel. The resulting structure is substantially planar sheet of hydrogel that can be used in building a larger procedural-based surgical training model.

BRIEF DESCRIPTION OF THE DRAWINGS

FIG. 1 is an exploded, top perspective view of an organ model according to the present invention.

FIG. 2 is a side, cross-sectional view of a rectum model with a simulated prostate system according to the present invention.

FIG. 3A is posterior, partial, cross-sectional view of two collagen layers located between a second tube and a third tube of a rectum model with according to the present invention.

FIG. 3B is a posterior, partial, cross-sectional view of a second tube, third tube and a thin hydrogel layer of a rectum model according to the present invention.

FIG. 3C is a posterior, partial, cross-sectional view of a second tube, third tube and a collagen layer of a rectum model according to the present invention.

FIG. 4A is an anterior, partial, cross-sectional view of two collagen layers located between a second tube and simulated prostate system of a rectum model according to the present invention.

FIG. 4B is an anterior, partial, cross-sectional view of a thin hydrogel layer located between a second tube and simulated prostate system of a rectum model according to the present invention.

FIG. 4C is an anterior, partial, cross-sectional view of a collagen layer between a second tube and a simulated prostate system of a rectum model according to the present invention.

FIG. 5 is a top perspective view of a multi-layered hydrogel according to the present invention.

DETAILED DESCRIPTION OF THE INVENTION

The material of the present invention is made from a dual interpenetrated cross-linked hydrogel network. The hydrogel is a mixture of two cross-linked polymers: an ionically cross-linked alginate network and a covalently cross-linked polyacrylamide network. The gel material is prepared by mixing an 8:3 ratio of acrylamide to alginate and water. In order to make the organ or tissue parts that are more realistic, color can be incorporated into the process. The colorant is added prior to deionized water being mixed with the acrylamide and alginate solids. Half the water being used to form the gel is used to make the colorant. A wash is created with the water and drops of acrylic paints. The amount and color of paint used varies depending on the organ See Table 1 below for organ color ratios that show how many parts of each color need to be mixed together for a particular organ and/or tissue part. The colored wash is then combined back with the other half of water and mixed with the acrylamide and alginate. Water content of the gel is approximately 86 weight percent. Ammonium persulfate (0.003 the weight of the acrylamide) and N,N-methylenebisacrylamide (0.006 the weight of acrylamide) are added to the solution as a photo initiator and a cross-linker respectively, for the acrylamide. Further, the solution is flushed with argon gas and N,N,N',N'-tetramethylethylenediamine (0.003 the weight of acrylamide) is added under an argon atmosphere as a cross-linking accelerator for the acrylamide. The final additive, calcium sulfate (0.136 weight of alginate), is an ionic cross-linker for the alginate. The slurry is constantly stirred throughout each step until the solution is homogeneous. The gel solution is cast into organ shaped molds and placed in an 85° C. oven for 30 minutes to cure. See the Example below for a specific hydrogel procedure example. To obtain hollow organs, the gel solution can be painted onto a mandrel and placed under a heat lamp to cure. The cured product is a tough, clear hydrogel or colored replica of the organ or tissue. The application of hydrogel organs makes the organ trays for surgical training more dynamic, the trays become more life-like as well as energy device compatible.

In another variation, the material of the present invention is made from a dual interpenetrated cross-linked hydrogel network. The hydrogel is a mixture of two cross-linked polymers: an ionically cross-linked alginate network and a covalently cross-linked polyacrylamide network. The gel material is prepared by mixing an 8:3 ratio of acrylamide to alginate and water. In order to make organs or tissue parts that are more realistic, color can be incorporated into the process. A colorant solution is prepared separate from the acrylamide and alginate mixture to allow for accessibility of different pigments while molding various tissue or organs.

The colorant solution is prepared by dissolving acrylic paints in deionized water. The amount and color of paint used varies depending on the organ. See Table I for organ color ratios that show how many parts of each color need to be mixed together for a particular organ and/or tissue part. From the total amount of water used to create the hydrogel, half the water comes from the colorant solution. The colored solution is then combined back with the other half of water which is mixed with the acrylamide and alginate. The total water content of the gel is approximately 86 wt %. Ammonium persulfate (approximately 0.3% the weight of the acrylamide) and N,N-methylenebisacrylamide (approximately 0.6% the weight of acrylamide) are added to the solution as a photoinitiator and a cross-linker respectively, for the acrylamide. Further, the solution is flushed with argon gas for approximately 10-15 minutes in order to displace the air with an inert gas, and then N,N,N',N'-tetramethylethylenediamine (approximately 0.3% the weight of acrylamide) is added under an argon atmosphere as a cross-linking accelerator for the acrylamide. The final additive, calcium sulfate (approximately 13.6% weight of alginate), is an ionic cross-linker for the alginate. The slurry is constantly stirred throughout each step until the solution is homogeneous. The gel solution is cast into organ shaped molds and placed in an 85° C. oven for 60 minutes to cure. See Example below for a specific hydrogel procedure example. To obtain hollow organs, the gel solution can be painted onto a mandrel and placed under a heat lamp to cure. The cured product is a tough, clear hydrogel or colored replica of the organ or tissue. The application of hydrogel organs makes the organ trays for surgical training more dynamic, the trays become more life-like as well as energy device compatible.

Organs and/or tissue made of the hydrogel of the present invention closely resemble and react to manipulation with energy devices similar to the way human organs do. The synthetic tissue made of the hydrogel of the present invention can be cut, cauterized and fused. Two layers of the hydrogel tissue according to the present invention can be separated along a plane using various monopolar and bipolar devices. Furthermore, vessels of the hydrogel can be fused and transected like real blood vessels. Mechanical devices such as scissors, graspers, and sutures can also be used on synthetic tissue made from the hydrogel of the present invention. The tissue has the strength to accommodate sutures and can be further reinforced with mesh to allow additional strength to accommodate sutures in a manner used for actual surgeries without concern for the suture tearing through the synthetic tissue and coming undone. In addition, when wetted the material becomes lubricious and slick making for a life-like feel. The compatibility of the hydrogel with other materials becomes useful when making large assemblies, such as organ trays comprising multiple tissue components for simulators because the synthetic organs not only need to bond to each other, but also are able to bond to the plastic base of the tray. The synthetic organs and tissues made of the hydrogel material should be stored in closed containers with minimal exposure to the atmosphere until ready for use. Due to being predominantly water, the hydrogel material can dry out over time if not stored properly. However, advantageously, the hydrogel of the present invention has the ability to reabsorb water allowing for it to rehydrate after losing moisture and to be used.

In another variation of the present invention, synthetic tissue is made as follows. Sodium metabisulfite is added as an additive to the above mentioned hydrogel. The sodium

metabisulfite is added to the solution prior to the calcium sulfate. The amount utilized is equivalent to the amount of ammonium persulfate present in the gel solution. The addition of the sodium metabisulfite allows the gel to be cured at room temperature. Once cast, the hydrogel begins to instantly cure, thus the need for a secondary oven cure is no longer necessary. This process shortens the time required for producing the gel. However, the resulting tissue lacks the same tear strength, elongation, and work time as its oven-cured counterpart.

Another approach utilizes adjusting the ratios of ingredients already present in the hydrogel solution. The two polymers of the hybrid hydrogel are what allow the gel to be elastic and still hold its shape. The 8:3 polymer ratio of acrylamide to alginate in the gel can be adjusted to enhance different properties of the gel. The amount of acrylamide can be increased to increase flexibility and elasticity of the gel; inversely, if the amount of alginate is increased, brittleness is amplified and tear resistance is decreased. The cross-linkers are further responsible for certain characteristics. The cross-linkers essentially entangle the polymer strands together forming a polymer network. Increasing the amount of cross-linkers causes the hydrogel to cure faster and lack elasticity and an insufficient amount of cross-linkers causes the formation of a jelly rather than a gel. The amount of water can also be varied, with the amount of water being inversely proportional to hardness. Gel with higher water content will be softer and will have the formation of a jelly. Ultimately, the ingredients of the hybrid hydrogel can be utilized to enhance different physical and mechanical properties.

Two other examples of replacement hydrogels are an acrylic acid based gel and a clay-based gel. In the acrylic acid hydrogel, an acrylate polymer is created through the polymerization of acrylic acid in an aqueous solution neutralized by sodium hydroxide. A sodium metabisulfite-ammonium persulfate redox reaction acts as an initiator for the polymerization process. The clay based hydrogel is a solution of sodium polyacrylate and clay nanosheets. A dendritic molecular binder (G3-binder) is added to the solution to initiate bonding. The resulting product is a clear, moldable hydrogel.

Besides hydrogel materials semiconductive silicones can be utilized to produce synthetic organs. Semiconductive silicones are silicone rubbers that have been doped with small particles of metal, commonly, nickel-graphite or aluminum. These metal particles essentially make a non-conductive silicone semiconductive by providing a medium for electricity to flow through. Semiconductive silicones are expensive and difficult to bond to other materials. In addition, the silicone needs to contain large amounts of metal particles to provide a short enough arcing distance for the electric current. The above materials and processes can similarly be engaged to manufacture organ trays that are energy compatible.

An exemplary organ model made of hydrogel material compositions described in this specification is shown in FIGS. 1-3. The organ model is a simulated rectum model **100**. The simulated rectum model **100** includes a first tube **102** made of any one of the hydrogel compositions described herein and dyed to have a pink color. In one variation, the hydrogel is selected to have a ratio of approximately 8:1 acrylamide to alginate and approximately 86% water. The first tube **102** defines a first lumen **103** extending between a proximal end and a distal end.

The simulated rectum model **100** further includes a second tube **104** defining a second lumen **105** and extending

between a proximal end and a distal end. The second tube **104** is made of yellow dyed hydrogel of any one of the hydrogel compositions described herein. In one variation, the hydrogel is selected to have a ratio of approximately 8:1 acrylamide to alginate and approximately 86% water. The second lumen **105** is dimensioned to receive the first tube **102** inside the second lumen **105** in a concentric-like fashion. The second tube **104** is adhered to the first tube **102** using cyanoacrylate glue. Alternatively, the second tube **104** is cured onto the first tube **102** and no glue is employed. The yellow color of the second tube **104** is selected such that the second tube **104** represents the mesorectum of a human colon.

The model **100** further includes a third tube **106**. The third tube **106** defines a third lumen **107**. The diameter of the third lumen **107** is dimensioned to receive the second tube **104** inside the third lumen **107** in a concentric fashion. The third tube **106** is adhered to the second tube **104** by being cured on top of the second tube **104**. The third tube **106** is made of any one of the hydrogel compositions described herein and dyed to have a yellow and/or orange color to represent a presacral fat layer. In one variation, the hydrogel is selected to have a ratio of approximately 8:1 acrylamide to alginate and approximately 86% water.

The simulated rectum model **100** further includes a fourth tube **108**. The fourth tube **108** defines a fourth lumen **109**. The diameter of the fourth lumen **109** is dimensioned to receive the third tube **106** inside the fourth lumen **109** in a concentric-like fashion. The fourth tube **108** is made of any one of the hydrogel compositions described herein and dyed to have a pink color. In one variation, the hydrogel is selected to have a ratio of approximately 8:1 acrylamide to alginate and 86% water. The fourth tube **108** is adhered to the third tube **106** with adhesive such as cyanoacrylate glue such as LOCTITE® 401 or 4902 cyanoacrylate glue manufactured by LOCTITE® of Westlake, Ohio. Alternatively, the fourth tube **108** is cured onto the third tube **106** and no adhesive is employed.

In one variation of the simulated rectum model **100**, the simulated rectum model **100** further includes a simulated prostate system **110** located and embedded between the third tube **106** and the fourth tube **108**. In one variation, the simulated prostate system **110** is located and embedded inside the third tube **106**. The simulated prostate system **110** is located at the anterior side of the model **100**. The simulated prostate system **110** includes any one or more of the following simulated anatomical structures: simulated prostate, simulated seminal vesicles, simulated bladder, simulated urethra, and simulated vas deferens. The simulated urethra and simulated vas deferens are made of silicone formed into a solid tube or other polymer. The simulated seminal vesicles are made of urethane or other foam overmolded onto the simulated vas deferens. The simulated prostate is made of urethane or other foam overmolded onto the simulated urethra.

In one variation of the simulated rectum model **100**, the simulated rectum model **100** further includes one or more collagen layer (not shown) located in any one or more of the following locations: (1) between the second tube **104** and the first tube **102**, (2) between the third tube **106** and the second tube **104**. The collagen layer is wetted and placed onto the cured hydrogel tube which is then placed in an oven to adhere it. In one variation, the second tube **104** is covered with a thin layer of collagen and the third tube **106** is covered with a thin layer of collagen and electro-surgical dissection takes places between the two adjacent layers of collagen. In another variation, a thin collagen layer is applied to the third

tube **106** only and dissection is between the second tube **104** and the collagen layer on the third tube **106**. In another variation, a thin first collagen layer is applied to the second tube **104**, a thin second collagen layer is applied to the first collagen layer. The prostate system **110** is adhered to the second collagen layer and care is taken to dissect around the prostate system between the first collagen layer and the second collagen layer. In another variation, a thin collagen layer is applied to the prostate system **110** and care is taken to dissect between the second tube **104** and the thin collagen layer to avoid the prostate system **110**.

The simulated rectum model **100** is fantastically suited for practicing transanal total mesorectal excision (TaTME) for cancer located in the lower rectum using electrosurgical devices and electrosurgery techniques. In such a surgical procedure, the cancerous rectum is approached through the anus into the first lumen **103** via a sealable port that is connected to channel. A purse-string suture is tied to seal off the cancerous location of the rectum that includes the tumor. In order to practice this suture technique, the first tube **102** is optionally provided with an embedded mesh layer so that sutures would be held in the first tube **102** and not tear through the hydrogel when pulled. In another variation, the purse-string suture is pre-made during the manufacturing process so that the surgeon can visually locate the suture and only practice techniques subsequent to purse-string suture placement. In the practice of the procedure, the surgeon will commence to dissect in the posterior direction and electro-surgically cut down through first tube **102** and into the second tube **104** which represents the mesorectum and circumferentially around the second tube **104** between the second tube **104** and the third tube **106** being careful not to penetrate into the simulated prostate system **110** and not to penetrate into the fourth tube **108** as can be seen in FIG. 2. Care is also taken not to enter the simulated mesorectum (second tube **104**) nor enter into the first tube **102**. The user carefully practices to dissect circumferentially around the first tube **102**. Exemplary posterior dissection locations and dissection pathways are illustrated in FIGS. 3A-3C. FIG. 3A illustrates a posterior dissection location between the second tube **104** and the third tube **106** and a dissection plane **111** in between two collagen layers **113** if they are employed. FIG. 3B illustrates a posterior dissection location with a dissection pathway between the second tube **104** and the third tube **106**, and in particular, between the second tube **104** and a thin hydrogel layer **112** located between the third tube **106** and the second tube **104**. FIG. 3C illustrates a posterior dissection location with a dissection pathway **111** between the second tube **104** and a collagen layer **113** adhered to the third tube **106**. After dissecting posteriorly, anterior dissection begins by dissecting through the thinner layer of the second tube **104**, visible in FIG. 2, until the third tube **106** is reached. Dissection proceeds between the second tube **104** and the third tube **106** along a dissection plane **111** until the posterior dissection is encountered. Exemplary anterior dissection locations and dissection pathways **111** that correspond to posterior dissection pathways **111** of the models configured as shown in FIGS. 3A, 3B and 3C are illustrated in FIGS. 4A, 4B and 4C, respectively. FIG. 4A illustrates an anterior dissection location with a dissection plane **111** lying between two collagen layers **113** if they are provided. FIG. 4B illustrates an anterior dissection location with a dissection plane **111** lying between the second tube **104** and the thin layer of hydrogel **112**. FIG. 4C illustrates an anterior dissection location with a dissection plane **111** lying between the second tube **104** and collagen layer **113** if

one is provided. Care is taken not to enter the third tube **106** to avoid risk damaging the prostate system **110**.

The proximal end of the simulated rectum model **100** may be attached to a transanal adapter. The transanal adapter is a support used to space apart the top cover from the base of a surgical trainer to provide access into the model from the side of the surgical trainer. An example of a surgical trainer is described in U.S. Pat. No. 8,764,452 incorporated by reference herein in its entirety. The transanal adapter includes an opening that is connected to the first lumen of the first tube **102**. Surrounding the opening of the transanal adapter, soft silicone is provided to simulate an anus. The practice of the surgical TaTME procedure is performed through the opening of the transanal adapter into the first lumen **103** as described above.

In one variation, the first tube **102** and the second tube **104** are made of hydrogel having a ratio of approximately 8:1 acrylamide to alginate and approximately 86% water and the third tube **106** and the fourth tube **108** are made of hydrogel having a ratio of approximately 8:3 acrylamide to alginate and approximately 86% water. Whereas the intersection of layers/tubes having the same ratio are substantially indistinguishable, the intersection of layers/tubes having different ratios are distinguishable making the intersection plane discernible and more easily separable, leading the practitioner along the correct dissection plane and making dissection easier than if the correct dissection plane was the intersection of layers/tubes having the same ratio.

The simulated rectum model **100** is assembled by first casting the material into hollow tube-like molds that are provided with mandrels. The casting of layers may begin from the innermost layer and proceed to the outermost layer or vice versa. For example, if the casting is to start from the innermost layer, a small tube is filled with material and allowed to cure in an oven. When removed from the small tube mandrel, the cured innermost layer is inserted into a larger diameter tubular mandrel of the desired diameter and the next layer is poured and allowed to cure. The combination is then removed and placed into a tubular mandrel having a larger diameter and the next layer is poured and so forth. Similarly, the model **100** may be constructed beginning with the outer layer and sequentially proceeding to the inner layer. Tubing is placed inside of a larger hollow tubing and the outermost space in between is filled with material until the desired layers is achieved working progressively until the innermost layer is poured. Any layer can be offset from the longitudinal axis to achieve a thicker or thinner layer posteriorly or anteriorly as needed such as for the second tube. If a purse-string suture is to be pre-made, the outer-to-inner manufacturing process would be employed. On the last innermost layer, instead of placing a mandrel in all of the way, material would be cast to completely fill in the rectum except for the top portion. On the top, a small mandrel would be placed allowing only the very top to be hollow. The mandrel could be designed to look like a purse-string, giving the user a visual cue that the purse-string suture has been already completed. To apply a collagen layer, synthetic or natural collagen casing is employed in the form of a sheet or cylinder. If provided in the form of a cylinder, it is cut into sheets. The collagen layer is then soaked in water and water is brushed onto the desired layer of application. The soaked collagen layer is then placed onto the layer of hydrogel. More layers are added as needed and the hydrogel layer and collagen layer are baked together in an oven to adhere the hydrogel to the collagen or the collagen to itself when multiple layers are employed side-by-side. The model **100** is held together by over molding the

layers or with cyanoacrylate glue. Silicone components of the model **100** such as the prostate system **110** are adhered to the hydrogel or collagen using cyanoacrylate glue. Urethane molds are employed and the molds may be surface treated with in a variety of ways including but not limited to plasma treating and flame treating to make the mold hydrophilic and improve spreading of hydrogel material into the mold, especially for a hydrogel formulation that does not include sodium metabisulfide. Certain model organ parts, especially thin sheet-like parts such as a simulated peritoneum, are formed by polybag casting. In polybag casting, the hydrogel material is poured into a bag. Any air pockets are pressed out and the bag is sealed and placed between two flat trays. Weights of approximately 2.5-5.0 pounds were laid on top of the trays and allowed to cure into a flat sheet to create an artificial peritoneum or omentum. Artificial vasculature also made of hydrogel may be embedded by arranging the artificial vasculature inside the polybag. Also, smaller hollow molds are utilized to manufacture simulated hollow vessels.

In another variation, the model **100** does not have a cylindrical shape to represent a rectum. Instead, the model **100** simply includes four layers **102**, **104**, **106**, **108** from top to bottom in the shape of a rectangular or square block as if the cylinder were to be cut open and laid flat as shown in FIG. 5. The block configuration of the layers permits the user to practice the procedures without being confined to a lumen configuration with the procedures performed trans-luminally. The block allows practitioners to simply practice the electrosurgical techniques in a laparoscopic environment such with the model **100** placed inside a cavity of a surgical trainer between a top cover and a base. In such a variation, the first layer **102** and the second layer **104** are made of hydrogel having a ratio of approximately 8:1 acrylamide to alginate and approximately 86% water and the third layer **106** and the fourth layer **108** are made of hydrogel having a ratio of approximately 8:3 acrylamide to alginate and approximately 86% water.

Any one of the hydrogels disclosed in this specification can be used to form at least part of a simulated tissue structure for the practice of surgical techniques, especially laparoscopic electro-surgical procedures wherein the simulated tissue structure is disposed inside an enclosure substantially enclosing the simulated tissue structure. An example of an enclosure includes a laparoscopic trainer in which a laparoscope is utilized to visualize the surgical field. The simulated tissue structure is not limited to artificial vessels, arteries, veins, one or more organs and tissues, hollow or solid, associated with the human lower rectum as described above and suitable for practicing a TaTME procedure. Also, the TaTME model described above may be made with two layers of hydrogel instead of four layers. In such a model the two layers made of hydrogel include the rectum layer and mesorectum layer, the first tube **102** and the second tube **104**, respectively, if the model is formed to have a tubular shape. A variation of such a TaTME model having two layers includes a mesh layer located between the two layers **102**, **104**. Of course, the TaTME model need not have a tubular shape. Any of the TaTME models may include artificial polyps to be practiced for removal using energy. A gallbladder model may include one or more of an artificial liver, artificial gallbladder, artificial peritoneum, artificial fascia, artificial duct(s), and one or more artificial artery. In an alternative variation of the gallbladder model, the artificial liver is excluded from being made of hydrogel and instead made of silicone or KRATON in order to localize the surge areas to the locations where a simulated procedure

would be performed. A simulated tissue structure is substantially made of any one of the hydrogels described herein. In one variation, the simulated tissue structure includes an artificial human ovarian organ that includes one or more of a simulated ovary portion, a uterine horn portion, uterus, ovary, fallopian tube, vagina, cervix, bladder, omentum, and peritoneum. The peritoneum and omentum may further include embedded simulated vasculature, hollow or solid, also made of hydrogel. Other artificial organs that are made of hydrogel and form at least part of a simulated tissue structure include an artificial stomach, kidney, rectum, aorta, tumor, and polyp. Any of the simulated tissue structures made of hydrogel described herein may include a mesh layer. Also, the simulated tissue structure may include two different hydrogels forming different parts of the simulated tissue. For example, as described above, part of a simulated tissue structure may be made with a hydrogel having an 8:3 formulation and another part having an 8:1 formulation. Also, part of a simulated tissue structure may be formed of a hydrogel according to the present invention and part made of silicone or other material and attached, connected, adjacent or in juxtaposition to the part made of hydrogel. For example, in a simulated appendectomy model, an artificial colon is made of silicone and an artificial peritoneum and vessels are made of hydrogel having one or more formulation described herein. In another example, in a simulated gallbladder model the artificial liver is made of silicone or KRATON and all other parts of the gallbladder model are made of hydrogel having one or more formulation described herein. In another example, an artificial rectum is made of silicone and artificial polyps of hydrogel described herein are adhered to the silicone rectum using cyanoacrylate glue.

In use, the simulated tissue structure according to the present invention is configured for use with electrosurgical units, including but not limited to monopolar, bipolar, harmonic or other devices employed in electrosurgery, in order to provide a realistic medium configured into an anatomical portion for the practice of using electrosurgical units, electrosurgical techniques, surgical procedures employing electrosurgical units alone and with other instruments encountered in surgery. The handling of electrosurgical units requires practice as does employing surgical techniques and learning specific procedures performed with the electrosurgical units. When an electrosurgical unit is applied, heat is generated by the electrical current traveling between two polarities in a bipolar system or from one electrical polarity to a ground in a monopolar system. Typically, in a monopolar system, the artificial tissue structure is located above and in contact with a grounding plate/pad which is connected to a ground. In one variation of the simulated tissue structure according to the present invention, that portion of the structure that is composed of hydrogel is placed in direct contact with the grounding pad/plate or other conductive surface. In the event, the entirety of the simulated tissue structure is configured such that the hydrogel is not in direct contact with the grounding pad, a conductive pathway, such as a wire or the like, is provided to contact the hydrogel portion and then pass across non-conductive portions of the model to contact the grounding pad. For example, in a gallbladder model such as the model described in U.S. Patent Application Publication No. US 2014/0370477 to Applied Medical Resources Corporation in California, the anatomical portion is connected to a support in order to permit the model to stand upright. If any one of the liver, peritoneum, gallbladder, vasculature, fascia, duct system or other component of the model is made of hydrogel, a wire is passed into that portion and then fed to contact a metallic

frame which is set inside the stand with the frame legs extending all the way through the stand to be exposed at the bottom surface of the stand which then can be placed atop a grounding pad. When the hydrogel structure is contacted with an electrosurgical unit, the temperature of the hydrogel structure will increase to a temperature that begins to vaporize the water content of the hydrogel in the location of contact. Because the hydrogel contains approximately 86% water by weight of the hydrogel structure, the model will generate steam that mimics the smoke created during electrosurgery performed on human tissue. Advantageously, the water vapor of the hydrogel structure is not odiferous compared with the smoke produced by real tissue. With prolonged contact with the electrosurgical unit, the water content will be reduced in the location of contact advantageously creating a simulated fusion or seal of tissue typically encountered in real surgery. Hence, the present invention not only advantageously simulates the look and feel of tissue structures that would undergo procedures that employ electrosurgery, but also, responds in manner that mimics real electrosurgery when electrosurgery is applied to the simulated tissue structures. The hydrogel of the present invention can be utilized to simulate dissection of tissue in addition to sealing and/or fusion via an electrosurgical unit.

TABLE 1

ORGAN	COLOR RATIO
Liver	4 red:1 black
Gallbladder	3 yellow:1 blue
Cystic duct	3 yellow:1 blue
Kidney	4 red:1 blue
Spleen	4 red:1 blue
Pancreas	4 yellow
Omentum	4 yellow:1 white
Mesentery	4 yellow:1 white (serial diluted 8 times)
Veins	3 blue:0.5 black
Arteries	5 red:0.25 black
Aorta	4 red

EXAMPLE

The following is an example procedure for making a simulated hydrogel liver according to the present invention. In a large glass beaker, add 33.75 g alginate and 90 g acrylamide. Dry mix the two solids until the mixture is uniform. Measure out 614 ml of deionized (DI) water. Add 307 ml (about half) of the 614 ml of DI water to the beaker with the powder mixture. Mix the solution to break apart any alginate adhered to the sides or bottom of the beaker. Once a homogenous solution is formed, maintain the mixing by placing the beaker under an overhead mixer or insert a stir bar and place on stir plate to continue mixing. The remaining 307 ml of water are added to a different beaker and used to prepare the colorant. For a simulated liver, 4 drops of red acrylic paint and 1 drop of black acrylic paint are added to the second jar of DI water and stirred on a stir plate until the water is a uniform color. The now colored 307 ml of DI water is combined back with the other half in the beaker of gel solution. The beaker of gel solution remains mixing on the overhead mixer or stir plate to dissolve all solids and allow for uniform mixing of the colorant. Keep solution stirring and add 0.250 g of ammonium persulfate (APS) and add 0.050 g N,N'-methylenebisacrylamide. Allow the APS and N,N'-MBAA to dissolve in the gel solution prior to

proceeding. Hand mix as necessary, since the solution is viscous and the lighter additives will not readily mix with the mixers.

While on the overhead mixer or stir plate, insert a thin hose into the bottom of the beaker of gel solution, the hose should be connected to the argon gas tank. Bubble in a stream of argon gas into the beaker for approximately 15 minutes. Afterwards, remove the hose from the solution and allow hose to sit above the surface and blow a stream of argon gas on top of the gel solution for another 5 minutes. After flushing the solution with argon gas remove the thin hose from the jar. The following step is also completed under argon conditions. Flush the headspace of the N,N,N',N'-tetramethylethylenediamine (N,N,N',N'-TMEDA) bottle with argon. Using a micropipette, pipette 0.290 milliliters of argon gas from the N,N,N',N'-TMEDA bottle head space and eject the gas off to the side, this should be done twice in order to flush the interior of the micropipette. Now, extract 0.290 ml of N,N,N',N'-TMEDA from the bottle using the same micropipette tip and eject into the gel solution. The N,N,N',N'-TMEDA bottle should be sealed quickly after use and stored in a dark area, away from moisture.

Continue stirring, make a slurry of calcium sulfate dihydrate (CaSO₄·2H₂O) and DI water. Add approximately 25 ml of DI water to 4.59 g of CaSO₄·2H₂O. Mix thoroughly and add slurry to the hydrogel solution. Wash the remains of the CaSO₄·2H₂O slurry with DI water and add to the hydrogel solution. Some white clouds may still remain from the addition of the CaSO₄·2H₂O. These clouds will disappear once hydrogel is cured. Allow gel slurry to mix at medium speed for approximately 1 minute. The gel slurry can now be poured into a liver mold and placed in an oven at 85° C. for 60 minutes to cure the gel. After 1 hour, the mold is removed from the oven and allowed to cool to room temperature. Once cool, the hydrogel liver can be removed from the mold. The final product is a life-like synthetic liver capable of being manipulated with energy devices in addition to mechanical devices.

It is understood that various modifications may be made to the embodiments of the synthetic tissue disclosed herein. Therefore, the above description should not be construed as limiting, but merely as exemplifications of preferred embodiments. Those skilled in the art will envision other modifications within the spirit and scope of the present disclosure.

We claim:

1. A method of making a surgical simulator, comprising the steps of:

- providing an acrylamide polymer;
- providing alginate polymer;
- providing water;
- mixing the water with the acrylamide and alginate to form a solution;
- adding ammonium persulfate to the solution;
- adding N,N-methylenebisacrylamide to the solution;
- adding calcium sulfate after the steps of adding ammonium persulfate and adding N,N-methylenebisacrylamide to the solution;
- casting the solution into a shape representative of an anatomical structure; and curing the solution to form a simulated electrosurgery model made of hydrogel for practicing and simulating electrosurgery.

2. The method of claim 1 including the step of adding N,N,N',N'-tetramethylethylenediamine in the amount of approximately 0.3 percent acrylamide by weight to the solution;

13

wherein the step of adding ammonium persulfate includes adding ammonium persulfate in the amount of approximately 0.3 percent acrylamide by weight to the solution;

wherein the step of adding N,N-methylenebisacrylamide includes adding N,N-methylenebisacrylamide in the amount of approximately 0.06 percent acrylamide by weight to the solution; and

wherein the step of adding calcium sulfate includes adding calcium sulfate in the amount of approximately 13.6 percent alginate by weight to the solution.

3. The method of claim 1 further including the step of flushing the solution with argon gas.

4. The method of claim 1 including the step of dry mixing the acrylamide polymer and alginate polymer prior to the step of mixing the water.

5. The method of claim 1 wherein the steps of:
forming a first layer of hydrogel having a first ratio of acrylamide to alginate by weight; and
overmolding a second layer of hydrogel having a second ratio of acrylamide to alginate by weight.

6. The method of claim 1 further including the steps of:
providing a colorant selected for a synthetic tissue structure; and
mixing the colorant with the water;

wherein the step of mixing the colorant with the water is performed prior to the step of mixing the water with the acrylamide and alginate to form a solution.

7. The method of claim 1 wherein the step of adding ammonium persulfate includes adding ammonium persulfate in the amount of approximately 0.3 percent acrylamide by weight to the solution.

8. The method of claim 1 wherein the step of adding N,N-methylenebisacrylamide includes adding N,N-methylenebisacrylamide in the amount of approximately 0.06 percent acrylamide by weight to the solution.

9. The method of claim 1 wherein the step of adding calcium sulfate includes adding calcium sulfate in the amount of approximately 13.6 percent alginate by weight to the solution.

10. The method of claim 1 wherein the step of providing acrylamide includes providing approximately 8 parts by weight acrylamide and the step of providing alginate includes providing approximately 3 parts by weight alginate.

14

11. The method of claim 1 wherein the step of providing acrylamide includes providing approximately 8 parts by weight acrylamide and the step of providing alginate includes providing approximately 1 part by weight alginate.

12. The method of claim 1 wherein the step of providing water includes providing approximately 86% total weight by water of the simulated electrosurgery model.

13. A surgical simulator for surgical training comprising:
a synthetic tissue structure substantially formed of a hydrogel including an ionically cross-linked alginate network cross-linked with a covalently cross-linked acrylamide network; the synthetic tissue structure includes a first layer formed of the hydrogel having a first ratio of acrylamide to alginate by weight; and a second layer formed of the hydrogel having a second ratio of acrylamide to alginate by weight; the second layer being adjacent to the first layer.

14. The surgical simulator of claim 13 wherein the first ratio is approximately 8:3 and the second ratio is approximately 8:3.

15. The surgical simulator of claim 13 wherein the first ratio is approximately 8:1 and the second ratio is approximately 8:1.

16. The surgical simulator of claim 13 wherein the first ratio is approximately 8:1 and the second ratio is approximately 8:3.

17. The surgical simulator of claim 13 further including a synthetic tissue structure embedded between the first layer and the second layer; wherein the embedded synthetic tissue structure is glued to the first layer using adhesive.

18. The surgical simulator of claim 13 further including an electrosurgical unit having a proximal end and an operable distal end configured to deliver energy at the distal end and controlled with a handle at the proximal end; wherein contact of the distal end of the electrosurgical unit with the hydrogel simulates electrosurgery.

19. The surgical simulator of claim 13 further including a simulated prostate system including one or more of an artificial prostate, artificial seminal vesicles, simulated bladder, simulated urethra, and simulated vas deferens; the simulated prostate system being located between the first layer and the second layer.

20. The surgical simulator of claim 13 wherein the first ratio and the second ratio are the same.

* * * * *

专利名称(译)	用于电外科训练和模拟的合成组织结构		
公开(公告)号	US10081727	公开(公告)日	2018-09-25
申请号	US15/208873	申请日	2016-07-13
[标]申请(专利权)人(译)	应用医疗资源		
申请(专利权)人(译)	应用医疗资源CORPORATION		
当前申请(专利权)人(译)	应用医疗资源CORPORATION		
[标]发明人	FELSINGER NATASHA CHEHAYEB SAM BOLANOS EDUARDO		
发明人	FELSINGER, NATASHA CHEHAYEB, SAM BOLANOS, EDUARDO		
IPC分类号	G09B23/28 C08L33/26 B29C39/00 G09B23/30 C08J5/12 A61B18/12 B29K33/00		
CPC分类号	C08L33/26 B29C39/003 C08J5/122 G09B23/30 C08J2405/04 B29K2005/00 B29K2033/26 C08J2333/26 A61B18/12		
优先权	62/257877 2015-11-20 US 62/161322 2015-05-14 US		
其他公开文献	US20160355676A1		
外部链接	Espacenet		

摘要(译)

提供了一种用于电外科训练和模拟的手术模拟器。手术模拟器包括一个或多个基本上由水凝胶制成的模拟组织结构，所述水凝胶包含离子交联的藻酸盐和共价交联的丙烯酰胺的双互穿网络。不同模拟组织结构的组合定义了用于各种电外科手术的实践的基于程序的模型，包括腹腔镜全直肠系膜切除术，经肛门全直肠系膜切除术，胆囊切除术和经肛门微创手术。还提供了制造模拟组织结构的方法。

