



US007708713B2

(12) **United States Patent**
Albrecht et al.

(10) **Patent No.:** **US 7,708,713 B2**
(45) **Date of Patent:** **May 4, 2010**

(54) **INSUFFLATING OPTICAL SURGICAL INSTRUMENT**

1,727,495 A 9/1929 Wappler

(75) Inventors: **Jeremy J. Albrecht**, Ladera Ranch, CA (US); **John R. Brustad**, Dana Point, CA (US); **Scott V. Taylor**, Mission Viejo, CA (US); **Gary M. Johnson**, Mission Viejo, CA (US); **Nabil Hilal**, Laguna Niguel, CA (US)

(Continued)

FOREIGN PATENT DOCUMENTS

DE 0365049 11/1921

(73) Assignee: **Applied Medical Resources Corporation**, Rancho Santa Margarita, CA (US)

(Continued)

(*) Notice: Subject to any disclaimer, the term of this patent is extended or adjusted under 35 U.S.C. 154(b) by 0 days.

OTHER PUBLICATIONS

International Search Report—dated Nov. 22, 2005 regarding International App. # PCT/US2005/022716.

(21) Appl. No.: **11/170,567**

(Continued)

(22) Filed: **Jun. 29, 2005**

Primary Examiner—Nicholas D Lucchesi

Assistant Examiner—Christopher D Koharski

(65) **Prior Publication Data**

US 2005/0288622 A1 Dec. 29, 2005

(74) *Attorney, Agent, or Firm*—Pui Tong Ho; Patrick Y. Ikehara; Kenneth K. Vu

Related U.S. Application Data

(57) **ABSTRACT**

(63) Continuation-in-part of application No. 10/956,167, filed on Oct. 1, 2004.

(60) Provisional application No. 60/584,302, filed on Jun. 29, 2004.

(51) **Int. Cl.**
A61M 37/00 (2006.01)

(52) **U.S. Cl.** **604/23**

(58) **Field of Classification Search** 604/19, 604/21, 23, 26, 45, 164.06; 606/185, 167
See application file for complete search history.

An insufflating surgical instrument adapted for movement across an abdominal wall to insufflate an abdominal region of a patient is disclosed comprising a shaft having an insufflation channel extending along an axis between a proximal end and a distal end, the insufflation channel being adapted for connection to a source of fluid under pressure at the proximal end, a tip at the distal end of the shaft, and at least one vent hole formed at the tip or the shaft being in connection with the insufflation channel and being adapted to expel the fluid under pressure to insufflate the abdominal region. At least one of the tip and the shaft is formed of a translucent or transparent material such as polycarbonate to facilitate visualization of the abdominal wall and the abdominal region.

(56) **References Cited**

U.S. PATENT DOCUMENTS

RE682 E 4/1838 Peale
396,754 A 1/1889 Mayfield
1,147,408 A 7/1915 Kells

7 Claims, 13 Drawing Sheets

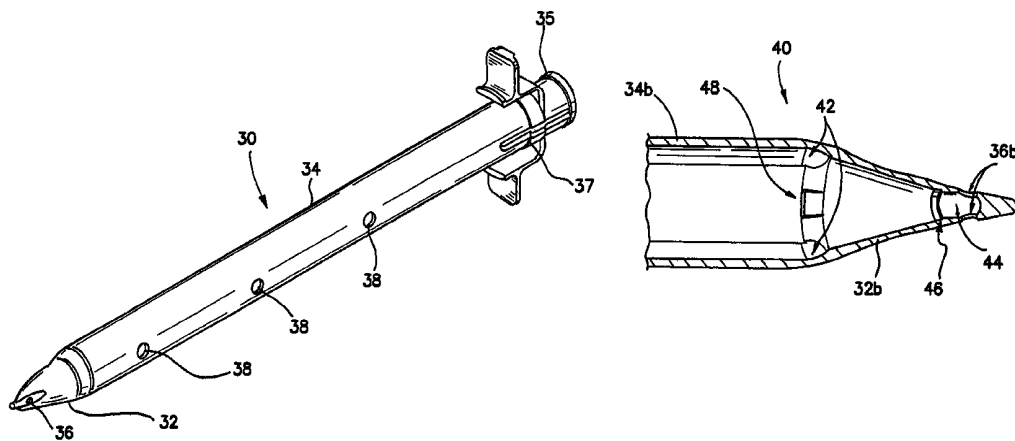

U.S. PATENT DOCUMENTS

1,845,727 A *	2/1932	Slaughter	27/24.1	5,542,845 A	8/1996	Jenkins	
2,102,274 A	12/1937	Larimore		5,569,291 A	10/1996	Privitera et al.	
2,699,770 A	1/1955	Fourestier et al.		5,569,292 A	10/1996	Scwemberger et al.	
2,932,294 A	4/1960	Fourestier et al.		5,609,562 A *	3/1997	Kaali	600/114
3,021,834 A	2/1962	Sheldon		5,613,954 A *	3/1997	Nelson et al.	604/167.03
3,042,022 A	7/1962	Sheldon		5,630,805 A *	5/1997	Ternamian	604/274
3,224,320 A	12/1965	Knudsen		5,658,236 A	8/1997	Sauer	
3,279,460 A	10/1966	Sheldon		5,662,673 A	9/1997	Kieturakis	
3,357,433 A	12/1967	Fourestier et al.		5,676,611 A	10/1997	Foster	
3,417,745 A	12/1968	Sheldon		5,685,820 A	11/1997	Riek et al.	
3,437,747 A	4/1969	Sheldon		5,720,761 A	2/1998	Kaali	
3,459,189 A	8/1969	Alley et al.		5,738,628 A	4/1998	Sierocuk et al.	
3,556,085 A	1/1971	Takahashi		5,752,970 A	5/1998	Yoon et al.	
3,613,684 A	10/1971	Sheridan		5,779,697 A *	7/1998	Glowa et al.	606/185
3,653,338 A	4/1972	Sauey		5,779,967 A *	7/1998	Hull	264/401
3,821,956 A	7/1974	Gordhamer		5,785,693 A	7/1998	Halning	
3,870,036 A	3/1975	Fiore		5,792,112 A	8/1998	Hart et al.	
3,961,621 A	6/1976	Northeved		5,797,888 A	8/1998	Yoon et al.	
3,994,287 A	11/1976	Turp		5,797,944 A	8/1998	Nobles et al.	
207,932 A	9/1978	Alvord		5,836,957 A	11/1998	Shulz	
4,112,932 A	9/1978	Chiulli		5,842,971 A	12/1998	Yoon	
4,180,068 A	12/1979	Jacobsen et al.		5,860,996 A	1/1999	Urban et al.	
4,191,191 A	3/1980	Auburn		5,891,013 A	4/1999	Thompson	
4,222,375 A	9/1980	Martinez		5,893,865 A	4/1999	Swindle	
4,248,214 A	2/1981	Hannah et al.		5,904,699 A *	5/1999	Schwemberger et al.	606/185
4,254,762 A	3/1981	Yoon		5,924,452 A	7/1999	Szpara et al.	
4,269,192 A	5/1981	Matsuo		5,957,884 A	9/1999	Hooven	
4,299,230 A	11/1981	Kubota		5,968,060 A *	10/1999	Kellogg	606/169
4,311,138 A	1/1982	Sugarman		6,001,084 A	12/1999	Riek et al.	
4,319,563 A	3/1982	Kubota		6,007,481 A	12/1999	Riek et al.	
4,356,826 A	11/1982	Kubota		6,053,194 A	4/2000	Nelson et al.	
4,429,856 A	2/1984	Jackson		6,092,551 A	7/2000	Bennett	
4,436,519 A	3/1984	O'Neill		6,228,063 B1	5/2001	Aboul-Hosn	
4,493,444 A	1/1985	Deli Bon et al.		6,387,043 B1	5/2002	Yoon	
4,498,902 A	2/1985	Ash et al.		6,508,759 B1	1/2003	Taylor et al.	
4,524,805 A	6/1985	Hoffman		6,520,939 B2	2/2003	Lafontaine	
4,535,773 A	8/1985	Yoon		6,556,160 B1 *	12/2003	Taylor et al.	604/158
4,535,808 A	8/1985	Johanson et al.		6,685,630 B2	2/2004	Sauer et al.	
4,537,593 A	8/1985	Alchas		6,887,194 B2	5/2005	Hart et al.	
4,567,882 A	2/1986	Heller		7,037,303 B2	5/2006	Beaufore et al.	
4,601,710 A	7/1986	Moll		7,056,294 B2 *	6/2006	Khairkahan et al.	600/585
4,779,613 A	10/1988	Hashiguchi et al.		2002/0183715 A1 *	12/2002	Mantell et al.	604/506
4,850,393 A	7/1989	Lashomb		2003/0023201 A1	1/2003	Aboul-Hosn et al.	
4,895,431 A	1/1990	Tsujiuchi et al.		2003/0187471 A1	10/2003	Cooper	
4,901,142 A	2/1990	Ikuno et al.		2004/0082969 A1	4/2004	Kerr	
4,972,827 A	11/1990	Kishi et al.		2004/0093000 A1	5/2004	Kerr	
5,030,210 A	7/1991	Alchas		2004/0106942 A1	6/2004	Taylor et al.	
5,057,082 A	10/1991	Burchette, Jr.		2004/0204671 A1	10/2004	Stubbs et al.	
5,066,288 A	11/1991	Deniego et al.		2004/0230155 A1	11/2004	Blanco et al.	
5,098,388 A	3/1992	Kulkashi et al.		2004/0254517 A1	12/2004	Quiroz-Mercado et al.	
5,104,388 A	4/1992	Quackenbush		2005/0149094 A1	7/2005	Kasahara et al.	
5,147,376 A	9/1992	Pianetti		2005/0159711 A1	7/2005	Kathrani et al.	
5,159,920 A	11/1992	Condon et al.		2005/0216028 A1	9/2005	Hart et al.	
5,163,941 A	11/1992	Garth et al.		2005/0227610 A1	10/2005	Zukor et al.	
5,217,441 A	6/1993	Shichman		2005/0283122 A1	12/2005	Nordgren	
5,246,425 A	9/1993	Hunsberger et al.		2005/0288622 A1	12/2005	Albrecht et al.	
5,250,068 A	10/1993	Ideguchi et al.		2006/0118189 A1	6/2006	Trekulve et al.	
5,256,149 A	10/1993	Banik et al.					
5,269,316 A	12/1993	Spitalny					
5,271,380 A	12/1993	Riek et al.					
5,279,567 A	1/1994	Ciaglia et al.					
5,290,276 A	3/1994	Sewell					
5,300,033 A *	4/1994	Miller	604/167.03				
5,334,150 A	8/1994	Kaali					
5,380,291 A	1/1995	Kaali					
5,389,077 A *	2/1995	Melinyshyn et al.	604/117				
5,391,153 A *	2/1995	Haber et al.	604/167.01				
5,392,766 A	2/1995	Masterson et al.					
5,431,151 A *	7/1995	Riek et al.	600/104				
5,441,041 A	8/1995	Sauer et al.					
5,445,615 A	8/1995	Yoon et al.					

FOREIGN PATENT DOCUMENTS

DE	1616107	4/1971
DE	2218901	10/1973
DE	2538758	3/1977
DE	29 29 233	1/1980
DE	2922239	12/1980
DE	4020956	1/1991
DE	4133073	4/1992
DE	4035146	5/1992
DE	4116648	11/1992
EP	0135364	3/1985
EP	0312787	4/1989
EP	0347140	12/1989
EP	0369936	5/1990

EP	0369937	5/1990	Co-Pending U.S. Appl. No. 10/489,403, filed Mar. 11, 2004; Title: Bladeless Obturator.
EP	0 474 124 A	3/1992	Co-Pending U.S. Appl. No. 10/514,313, filed Nov. 12, 2004; Title: Blunt Tip Obturator.
EP	0724 864 A	8/1996	Co-Pending U.S. Appl. No. 10/956,167, filed Oct. 3, 2003; Title: Bladeless Optical Obturator.
FR	1370580	8/1964	U.S. Appl. No. 10/745,262, filed Dec. 23, 2003; Title: Catheter With Conduit Traversing Tip.
SU	0942730	7/1982	Co-Pending U.S. Appl. No. 11/868,883, filed Oct. 8, 2007; Title: Visual Insufflation Port.
SU	1328658	8/1987	Co-Pending U.S. Appl. No. 10/346,846, filed Jan. 17, 2003; Title: Surgical Access Apparatus and Method.
SU	1329769	8/1987	Co-Pending U.S. Appl. No. 10/805,864, filed Mar. 22, 2004; Title: Surgical Access Port and Method.
WO	WO 97/40758 A1	11/1997	
WO	WO 01/08563 A	2/2001	

OTHER PUBLICATIONS

The International Bureau of WIPO, International Preliminary Report on Patentability for international application No. PCT/US2005/022716, mailed Jan. 18, 2007.

* cited by examiner

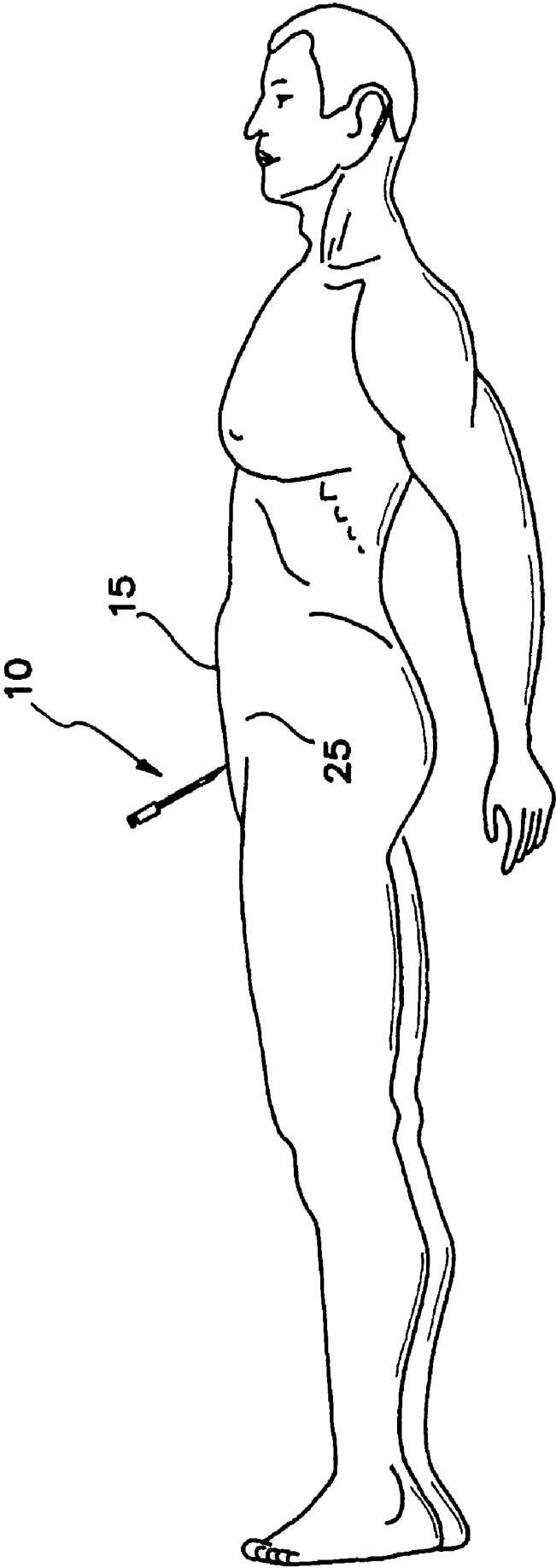

FIG. 1
PRIOR ART

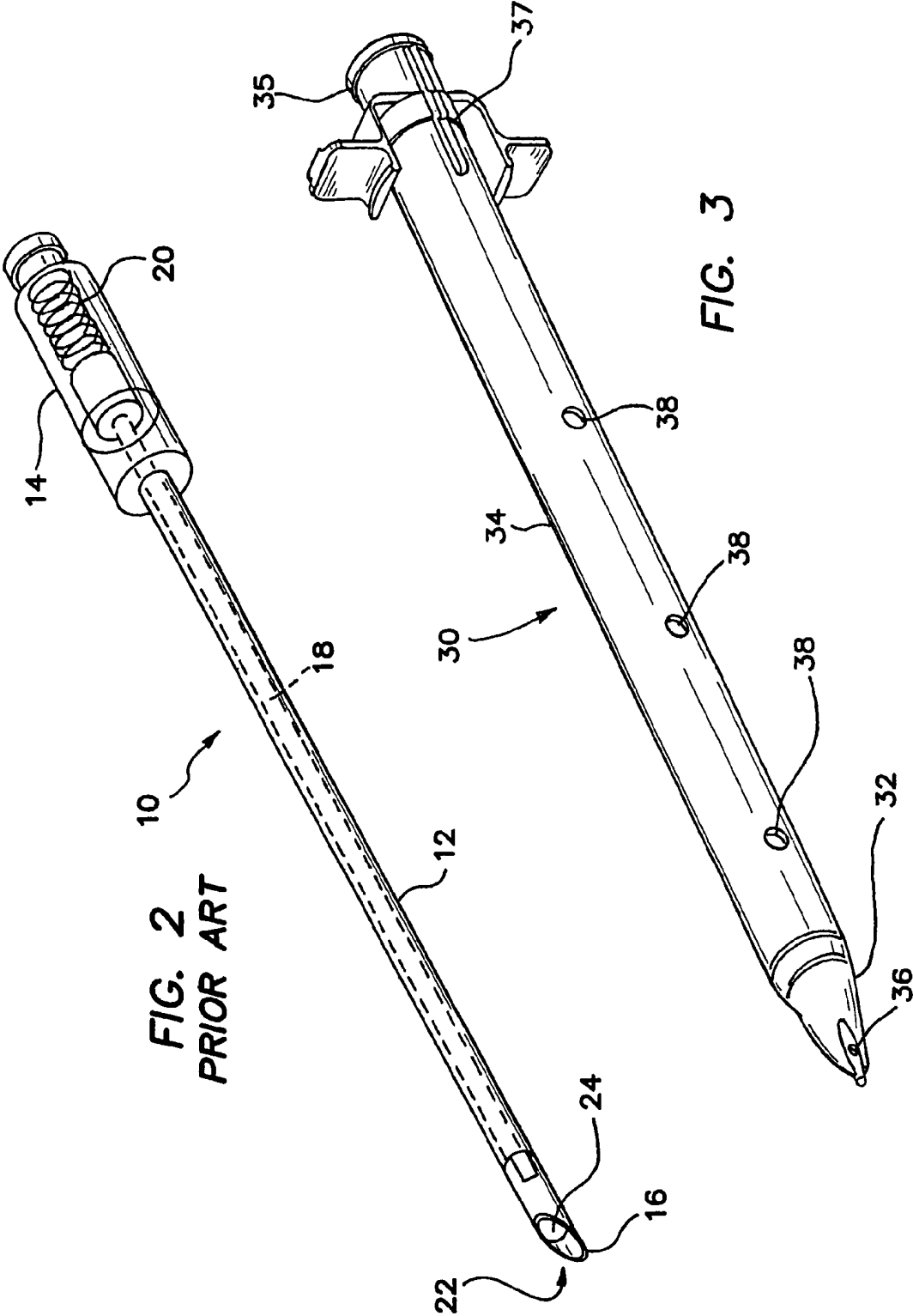

FIG. 2
PRIOR ART

FIG. 3

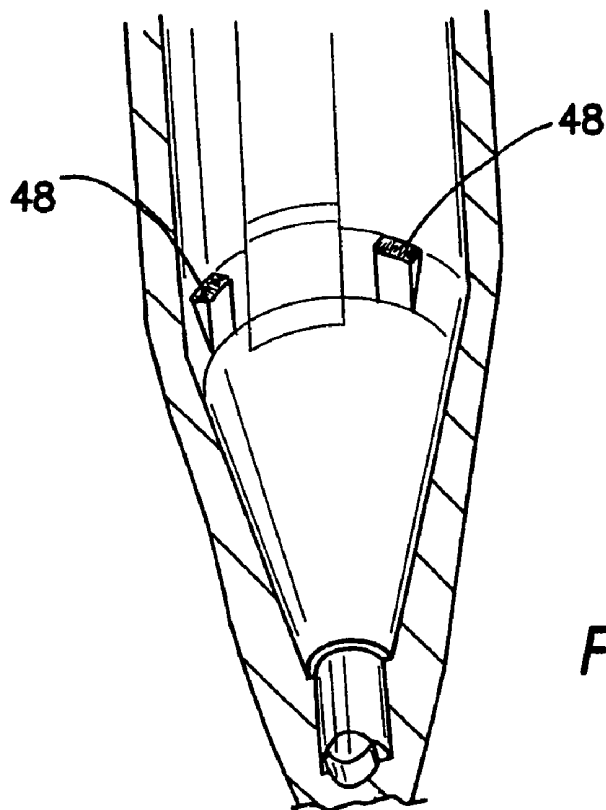
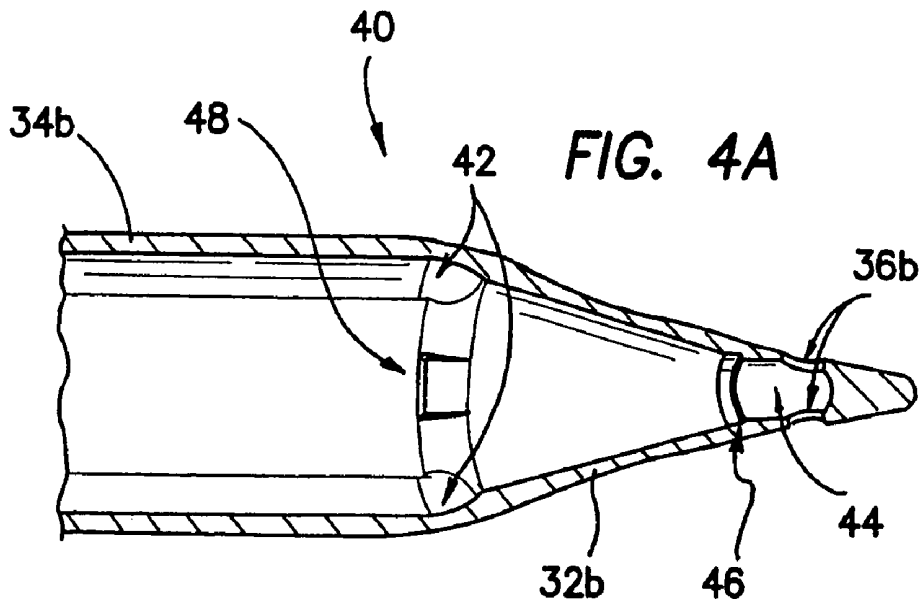

FIG. 4B

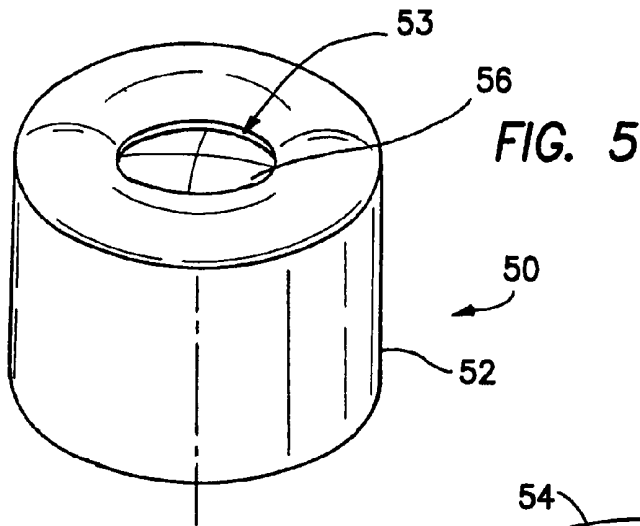

FIG. 5

FIG. 6A

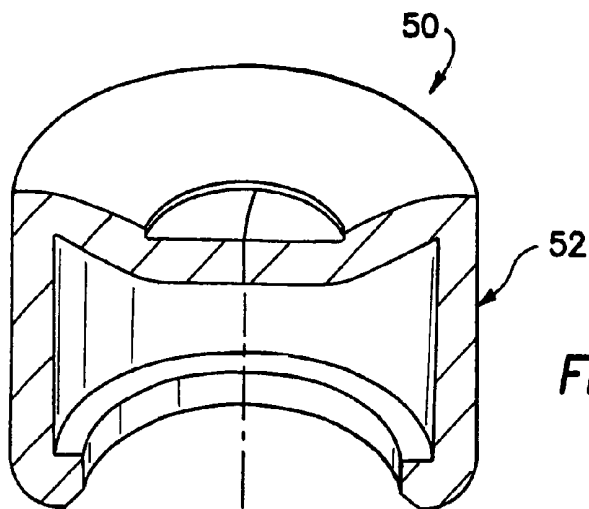
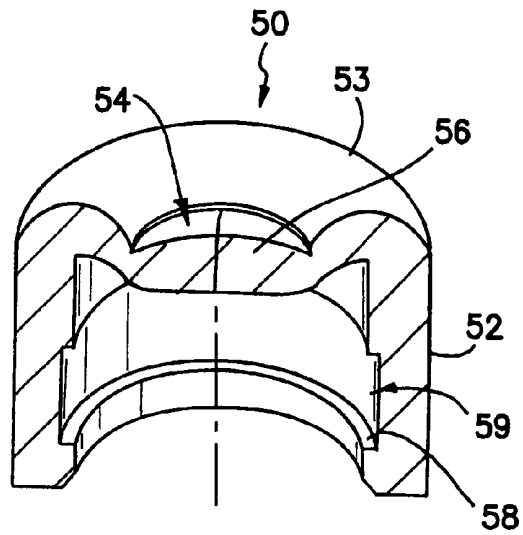

FIG. 6B

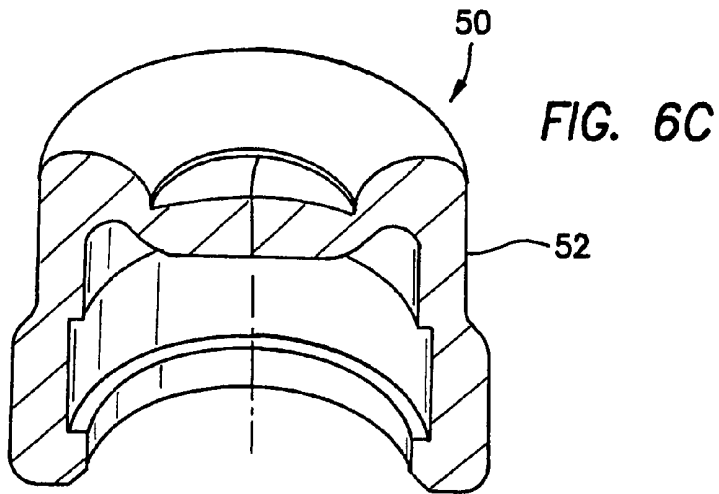

FIG. 6D

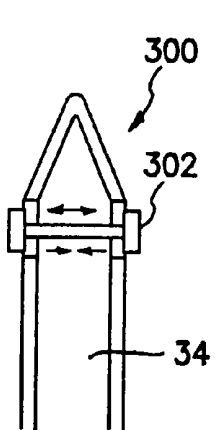
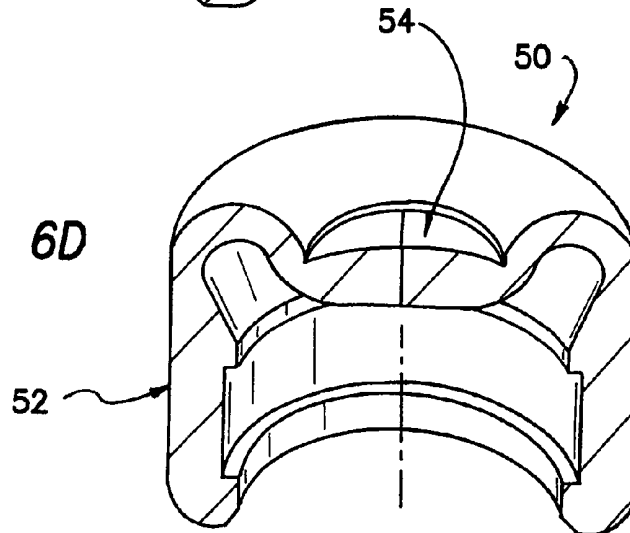

FIG. 15A

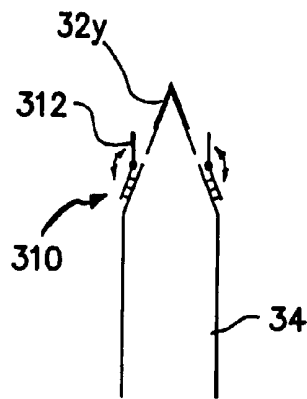

FIG. 15B

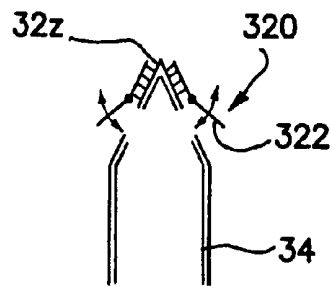

FIG. 15C

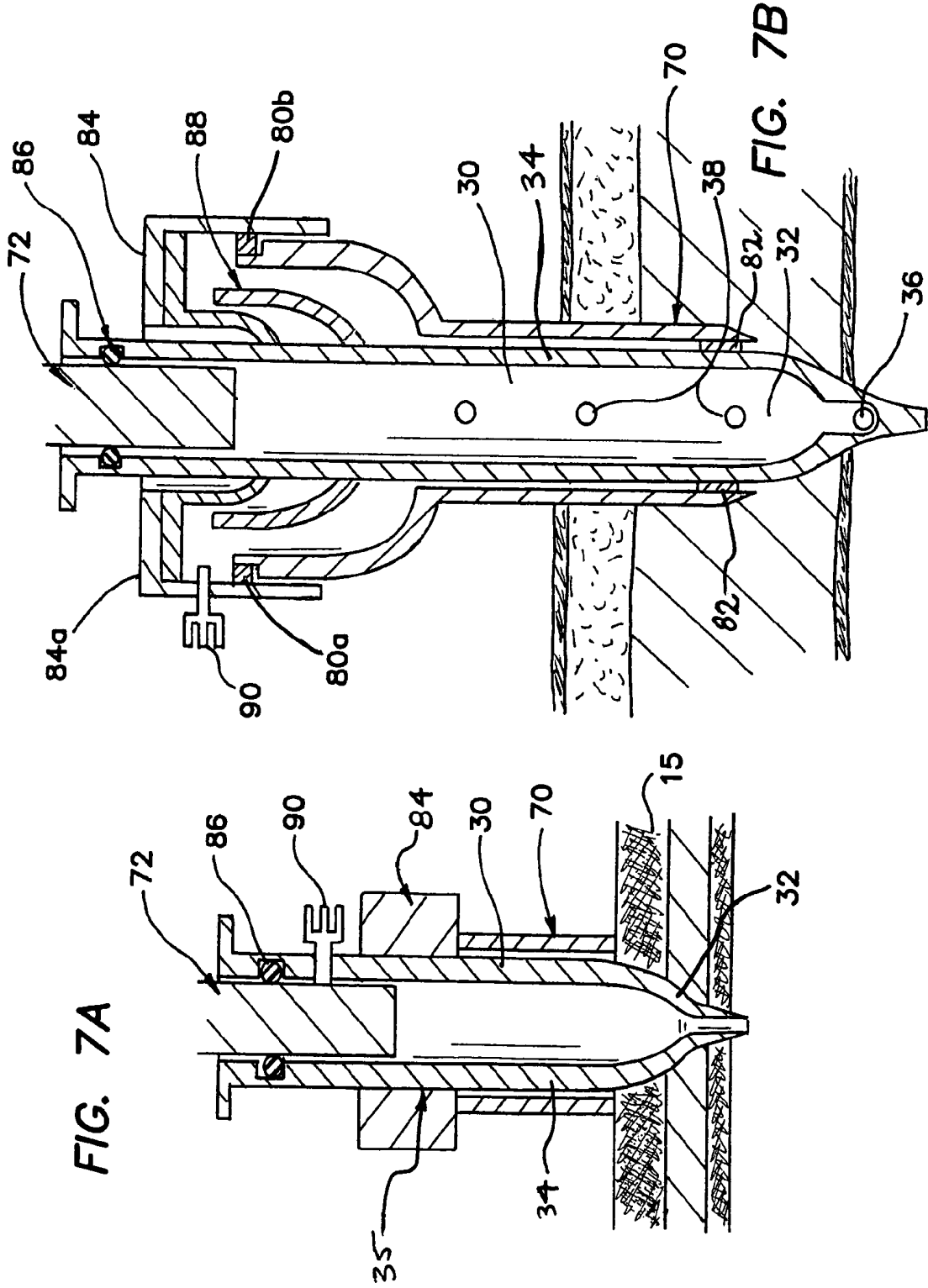

FIG. 7A

FIG. 7B

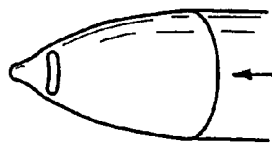

FIG. 8A

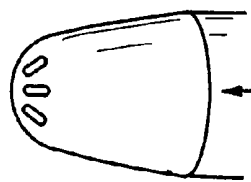

FIG. 8B



FIG. 8C



FIG. 8D

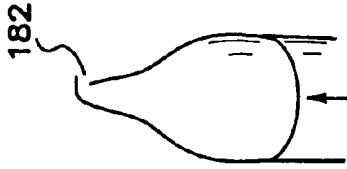

FIG. 8E

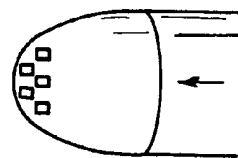

FIG. 8F

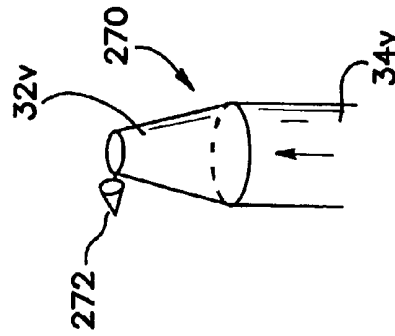

FIG. 14A

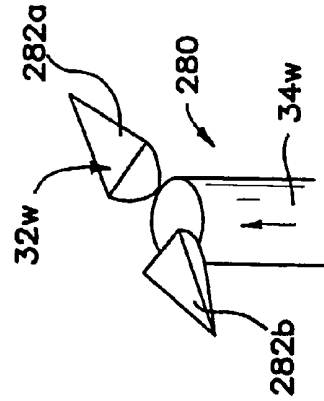

FIG. 14B

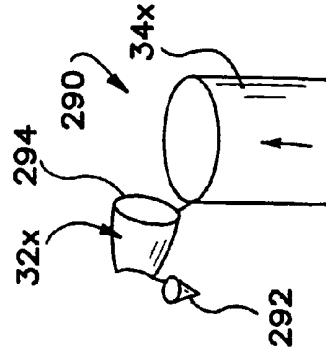

FIG. 14C

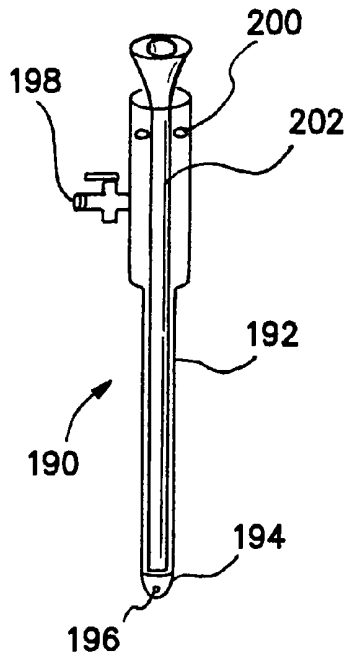

FIG. 9

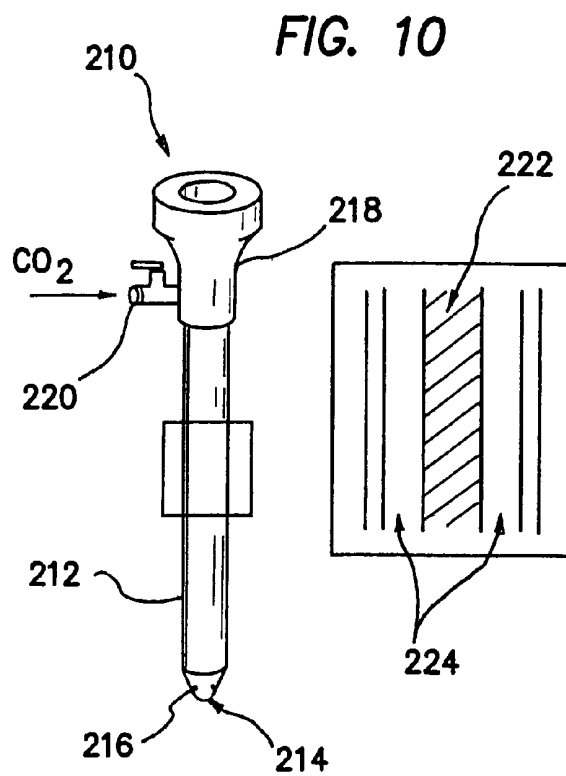
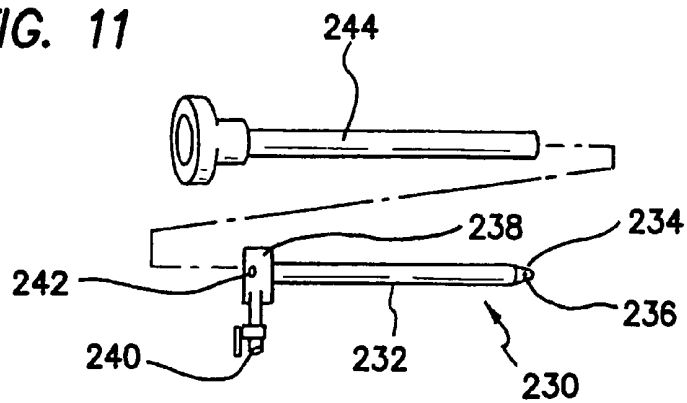

FIG. 10

FIG. 11



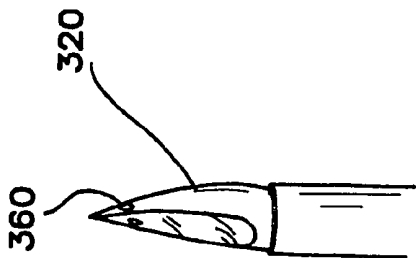

FIG. 12A

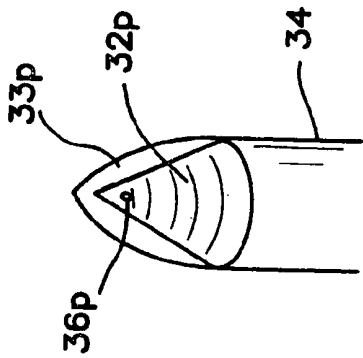

FIG. 12B

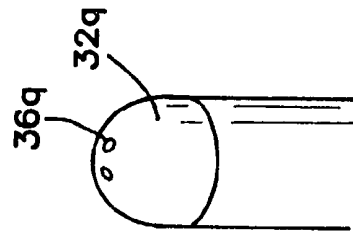

FIG. 12C

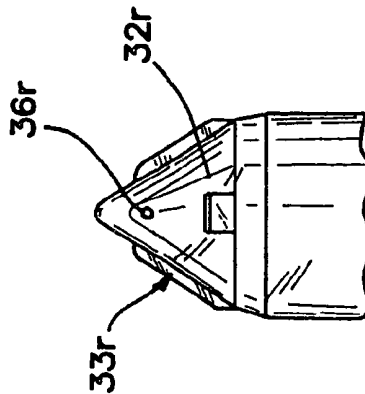

FIG. 12D

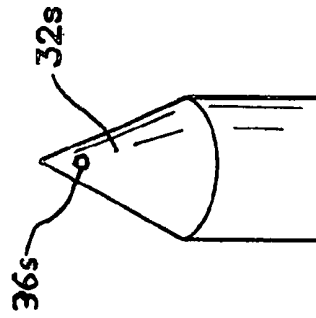
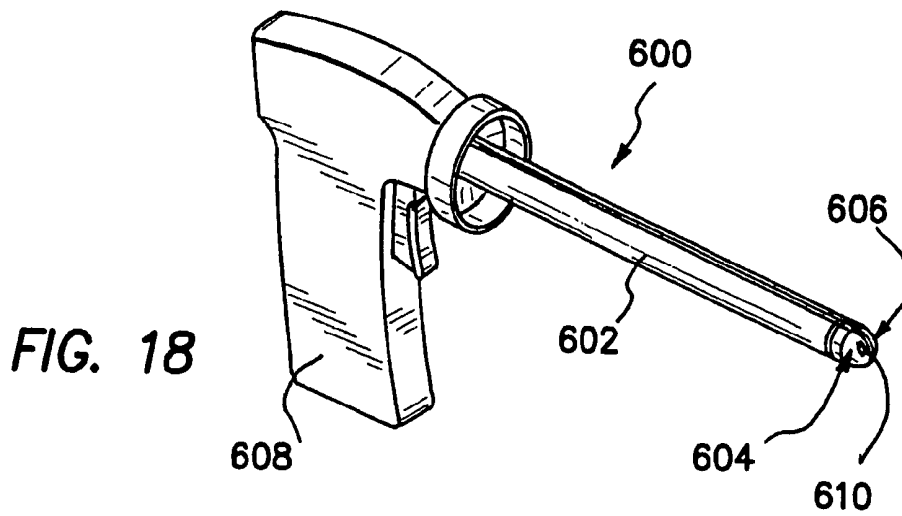
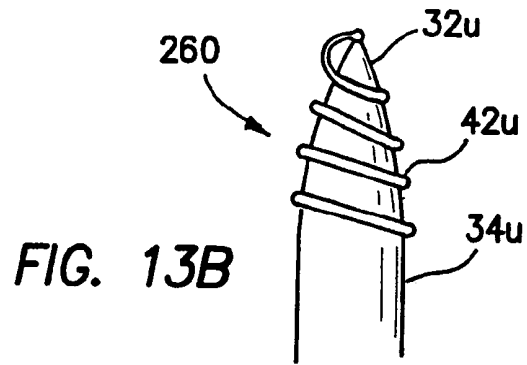
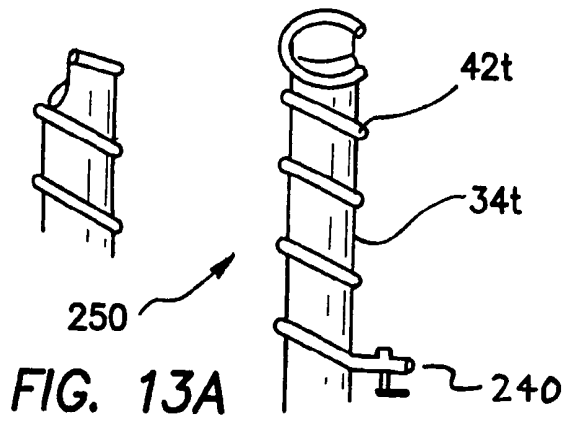

FIG. 12E



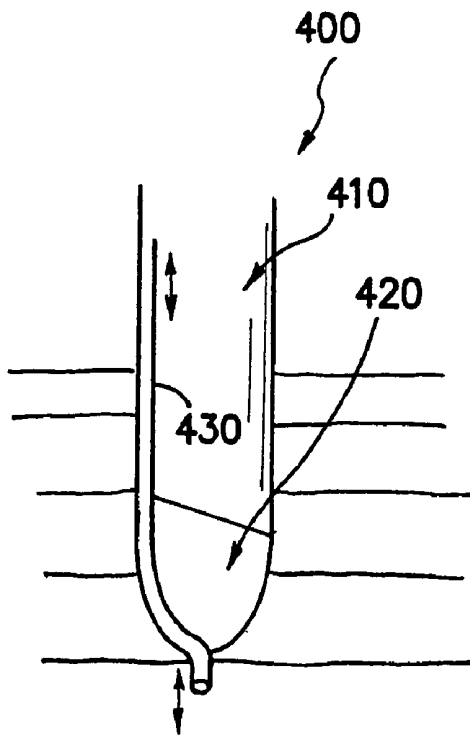

FIG. 16

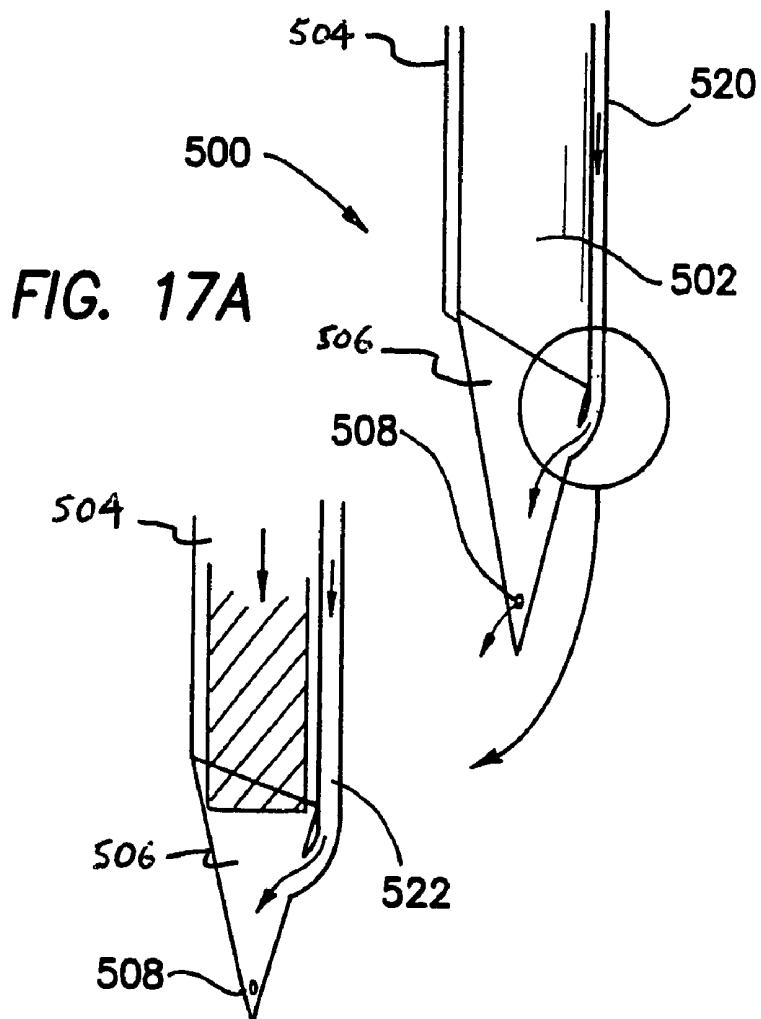
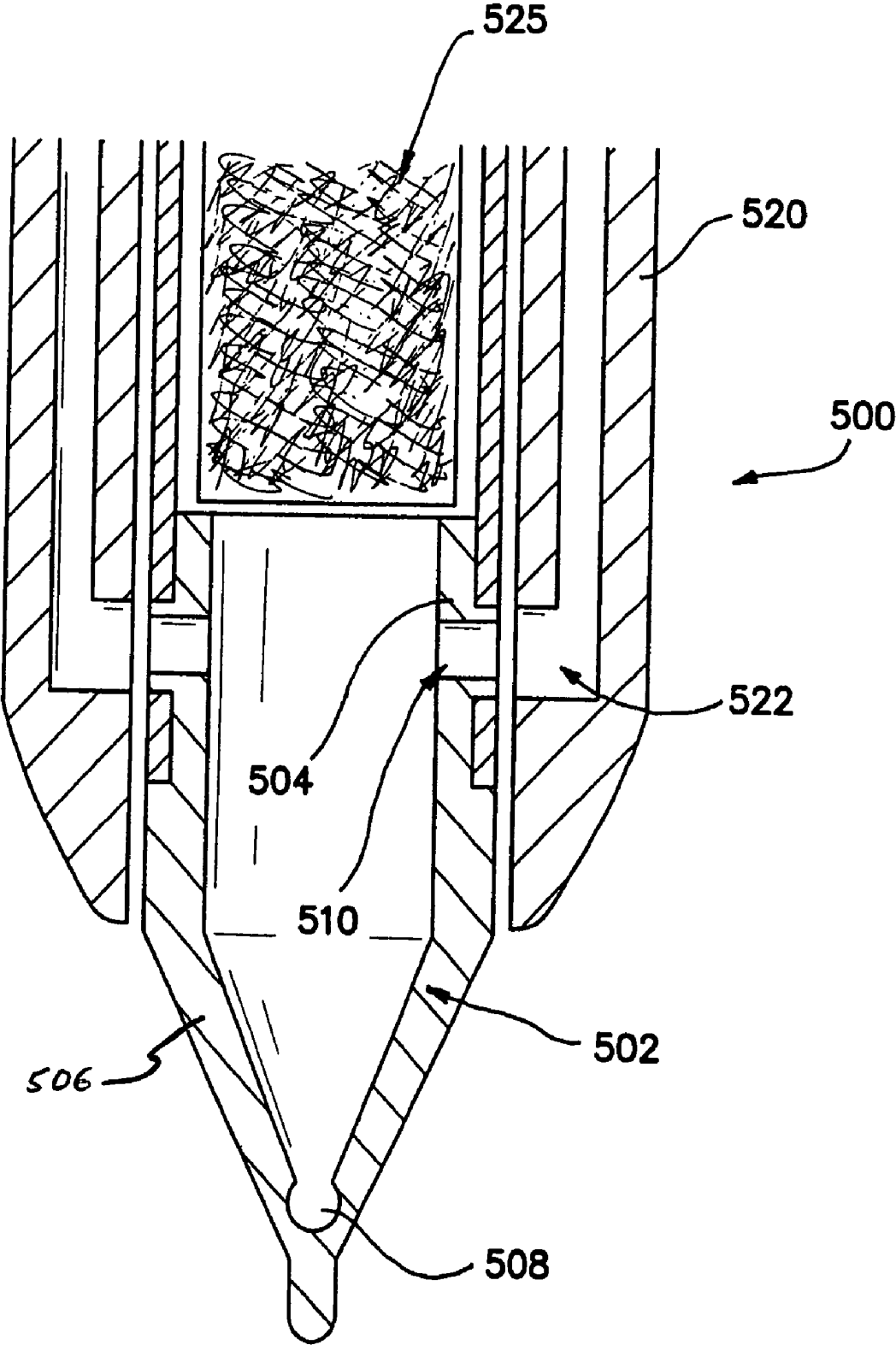

FIG. 17A

FIG. 17B



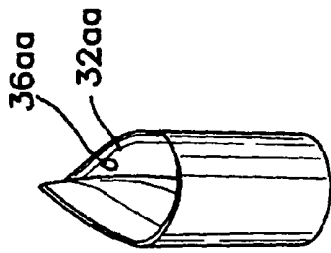

FIG. 19A

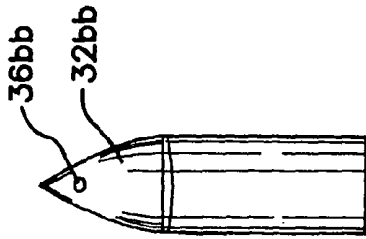

FIG. 19B

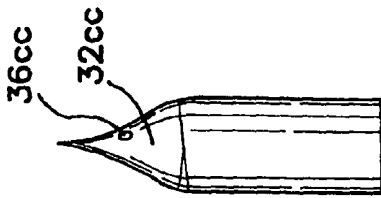

FIG. 19C

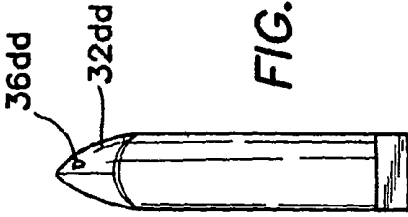

FIG. 19D

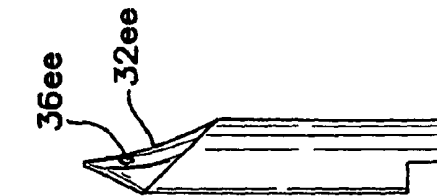

FIG. 19E

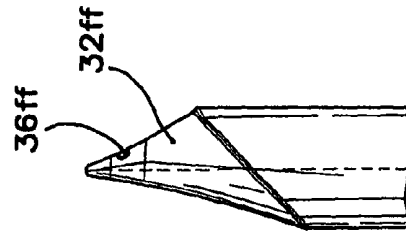

FIG. 19F

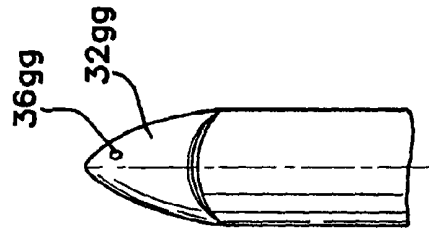

FIG. 19G

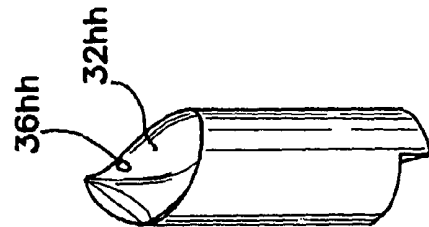

FIG. 19H

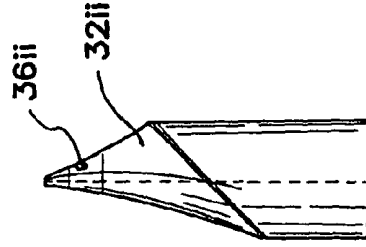

FIG. 19I

INSUFFLATING OPTICAL SURGICAL INSTRUMENT

This is a non-provisional application claiming the priority of provisional application Ser. No. 60/584,302, filed on Jun. 29, 2004, entitled "Insufflating Optical Surgical Instrument," which is fully incorporated herein by reference. This non-provisional application is also filed as a continuation-in-part application claiming the priority of patent application Ser. No. 10/956,167, filed on Oct. 1, 2004, entitled "Bladeless Optical Obturator," which is fully incorporated herein by reference.

BACKGROUND OF THE INVENTION

1. Field of the Invention

This invention generally relates to surgical instruments and, in particular, to surgical instruments providing visual entry and visual insufflation.

2. Discussion of the Prior Art

Laparoscopic surgery of the abdominal area typically requires the introduction of an insufflation gas into the peritoneal cavity of the patient. The insufflation gas is usually pressurized to about 10 mm Hg above atmospheric pressure. This in turn lifts the abdominal wall away from the organs underlying it. Cannulas having seals are then placed at various locations through the abdominal wall to allow the use of a laparoscope and operating instruments. It is well known that establishing access to a non-inflated peritoneal cavity can be a very dangerous part of any laparoscopic procedure. The most common method to achieve insufflation is to pass a sharp needle through the abdominal wall and into the abdominal region, and then inject a gas through the needle and into the region thereby creating an enlarged or ballooned cavity to accommodate a laparoscopic procedure. Unfortunately, insertion of the needle has been required without any visual aid to facilitate location of the sharp needlepoint. In order to reduce the probability of inadvertent penetration of delicate internal organs in this "blind" procedure, the sharp insufflation needle has been provided with a spring-loaded and retractable safety mechanism.

The safety mechanisms associated with most insufflation needles consist of a blunt or rounded member disposed within the lumen of the needle, and biased by a spring to an extended position beyond the needle tip. This spring must be responsive to the insertion pressure during placement of the needle but must be capable of immediately moving forward when that pressure is relieved. This is a highly mechanical event at best and offers less than optimal arrangement. As pointed out above, a drawback of this procedure is it is performed blindly. A consequence of this blind insertion is the surgeon may inadvertently damage the organs and tissues underlying the abdominal wall such as major blood vessels and the intestinal tract. Once access is gained, it can take several minutes for the gas to insufflate the abdomen and while this is happening the surgeon may be unaware of any complications caused by the insertion of the needle.

Another commonly used method of gaining initial access to the peritoneal cavity is by using a procedure known as the Hasson technique. This method involves making a mini-laparotomy and using the fingers to bluntly dissect the tissues of the abdominal wall and thereby creating an access similar to an open surgical procedure. This method is generally considered to be safer but not without risks, and results in an access site that is not well suited for the subsequent introduction and use of a laparoscopic cannula. The cannula is typically held in place with an additional device that allows the cannula to be

tied down with sutures to prevent it from slipping out of the abdominal wall. This also leaves a large defect and is difficult to perform in large abdominal walls.

Some surgeons have used trocars designed for use with laparoscopes for the initial entry into the peritoneal cavity. These devices allow the placement of a laparoscope through the internal diameter of the trocar and have a trocar tip that is made of clear plastic to allow the surgeon to visualize the passage of the tip through the abdominal wall. However, in order to allow the subsequent introduction of insufflation gas through the cannula, the trocar and cannula must be inserted all the way through the wall of the abdomen and this in turn can be potentially dangerous as the tip of the trocar may have to advance as much as one inch beyond the distal surface of the abdominal wall and into the underlying anatomical structures. As such, there remains a need in the art for an improved surgical instrument that provides visual entry and visual insufflation, and that minimizes the risks of damaging organs, tissues and vessels underlying a body wall.

SUMMARY OF THE INVENTION

The invention is directed to surgical instruments providing visual entry and visual insufflation with minimal risks of injury to organs, tissues and vessels underlying a body wall. It is appreciated that the concept of the invention may be applied to any surgical instrument that provides the ability to insufflate under direct vision of the site of insufflation, regardless of the size of the instrument and the type of insufflation fluid. More specifically, the surgical instrument provides the ability to transfer an insufflation fluid such as CO₂ or saline from outside a patient to inside a surgical cavity under vision. The insufflation fluid may be transferred inside a lumen, along a body channel or through a coiled tube of a surgical instrument or scope used for vision.

In a first embodiment of the invention, an insufflating surgical instrument adapted for movement across an abdominal wall to insufflate an abdominal region of a patient is disclosed comprising a shaft having an insufflation channel extending along an axis between a proximal end and a distal end, the insufflation channel being adapted for connection to a source of fluid under pressure at the proximal end. The insufflating surgical instrument further comprises a tip at the distal end of the shaft and at least one vent hole formed at the tip or the shaft being in connection with the insufflation channel and being adapted to expel the fluid under pressure to insufflate the abdominal region. In one aspect, at least one of the tip and the shaft is formed of a transparent material to facilitate visualization of the abdominal wall and the abdominal region. With this aspect, the shaft and the tip are configured to enable insertion of a laparoscope. In particular, the shaft includes a lumen extending along the axis between the proximal end and the distal end to enable insertion of the laparoscope. The lumen and insufflation channel may be formed as separate channels or as one shared channel. The insufflating surgical instrument may further comprise a second vent hole being in connection with the insufflation channel and formed along the shaft. It is appreciated that the tip may be blunt, the shaft and the tip may be integrally formed, and the vent hole may be of any geometric shape including round, oval, square and rectangular. With this aspect, at least one of the tip and the shaft may be formed of a translucent or a transparent material such as polycarbonate. The blunt tip may further comprise a marker to indicate when the vent hole has been positioned for insufflation. More specifically, the marker indicates the point where the vent hole has penetrated the abdominal wall. The shaft of the invention may further comprise a scope lock to

prevent the laparoscope from being inserted too far into the shaft and block at least one of the insufflation channel and the vent hole. In another aspect, the tip may be sharp, pointed or bladed to facilitate penetration of body tissue.

The insufflating surgical instrument may further comprise a seal housing disposed at the proximal end of the shaft. The seal housing comprises a septum seal and a plurality of leaflets forming an instrument seal in the presence of a laparoscope, and providing a zero seal in the absence of an instrument. The thickness of the leaflets may be formed to a desired dimension to create a pressure release mechanism that inverts and releases pressure if the abdominal pressure within the patient undergoes a sudden spike. The septum seal may be formed of an elastomeric material including Kraton, silicone and the like. The seal housing may further comprise a duckbill or a double duckbill valve distal of the leaflets to further limit gas or fluid escape.

In another aspect of the invention, an insufflating surgical instrument adapted for penetrating an abdominal wall to insufflate an abdominal region of a patient is disclosed comprising a shaft having an insufflation channel extending along an axis between a proximal end and a distal end, the insufflation channel being adapted for connection to a source of fluid under pressure at the proximal end. The insufflating surgical instrument further comprises a tip at the distal end of the shaft, the tip having a first, closed position during penetration of the abdominal wall and a second, opened position to expel the fluid under pressure to insufflate the abdominal region after penetration of the abdominal wall. The tip may be a flip-top that automatically opens upon traversing the abdominal wall or a flapper valve that opens to the second position when gas or fluid is introduced at the source and into the insufflation channel. The insufflating surgical instrument may further comprise a retention member for connecting the shaft and the flip-top. The flip-top may be a two-piece flip-top, the flapper valve may be a reverse flapper valve or a spring-based flapper valve, and the retention member may be one of a spring, a spring wire, an offset hinge or a living hinge. In another aspect, the tip may comprise at least two petals that reposition to the side of the shaft in the second insufflation position.

Another aspect of the invention is a laparoscopic insufflating surgical instrument adapted for movement across an abdominal wall to insufflate an abdominal region of a patient comprising an elongate tube having a distal tip, an insufflation channel extending between a proximal end and a distal end, the elongate tube being adapted for connection to a source of fluid under pressure at the proximal end, and being adapted at the distal end to expel the fluid under pressure to insufflate the abdominal region, and an optical element disposed at the distal end of the elongate tube to facilitate visualization of the abdominal wall and the abdominal region. With this aspect, the distal tip is defined by a curved surface, the distal tip being translucent or transparent, and the optical element being a light or an endoscope. It is appreciated that the insufflating surgical instrument may be an insufflating Veress needle.

Another aspect of the invention is directed to a laparoscopic insufflating surgical instrument adapted for movement across an abdominal wall to insufflate an abdominal region of a patient comprising an elongate tube having a proximal end and a distal end, an optical element disposed at the distal end of the elongate tube to facilitate visualization of the abdominal wall and the abdominal region of the patient, and an insufflation channel having a proximal end and a distal end extending along the proximal end and the distal end of the elongate tube, the insufflation channel being adapted for connection to a source of fluid under pressure at the proximal end, and to expel the fluid under pressure to insufflate the abdomi-

nal region at the distal end. With this aspect, the insufflation channel is formed into a coil around the elongate tube. It is further appreciated that the distal end of the elongate tube may be tapered to form a generally cone-tipped end.

In yet another aspect of the invention, there is disclosed an insufflating surgical instrument adapted for movement across an abdominal wall to insufflate an abdominal region of a patient, the surgical instrument comprising an insufflating cannula having a wall forming a first lumen extending along an axis between a proximal end and a distal end, and a first insufflation channel formed in the wall extending along the axis between the proximal end and the distal end and being adapted for connection to a source of fluid under pressure at the proximal end. The insufflating surgical instrument further comprises an insufflating trocar having a shaft with a second lumen extending along the axis between a proximal end and a distal end, a second insufflation channel formed at the distal end and being adapted for alignment with the first insufflation channel of the cannula to expel the fluid under pressure to insufflate the abdominal region, and a tip at the distal end of the shaft, and at least one vent hole formed at the tip of the trocar being in connection with the second insufflation channel of the trocar. The insufflating surgical instrument may further comprise a laparoscope adapted for insertion at the proximal end of the trocar and advanced to the distal end as the trocar is placed through the abdominal wall.

Another aspect of the invention is directed to a method for using an insufflating surgical instrument to create access across an abdominal cavity and to insufflate an abdominal region of a patient, the method comprising providing a transparent shaft having a lumen and an insufflation channel extending along an axis between a proximal end and a distal end, the insufflation channel being adapted for connection to a source of fluid under pressure at the proximal end, a tip at the distal end of the shaft, and at least one vent hole formed at the tip or the shaft being in connection with the insufflation channel and adapted to expel the fluid under pressure to insufflate the abdominal region; moving the shaft across the abdominal wall to place the distal end of the shaft in the abdominal region; and expelling gas or fluid under pressure through the insufflation channel to insufflate the abdominal region of the patient. The method for using the insufflating surgical instrument may further comprise the step of visualizing the abdominal cavity through the lumen of the shaft.

These and other features of the invention will become more apparent with a discussion of the various embodiments in reference to the associated drawings.

DESCRIPTION OF THE DRAWINGS

The accompanying drawings, which are included in and constitute a part of this specification, illustrate the embodiments of the invention and, together with the description, explain the features and principles of the invention. In the drawings:

FIG. 1 illustrates a typical laparoscopic abdominal surgery of the prior art;

FIG. 2 illustrates a perspective view of an insufflation needle of the prior art;

FIG. 3 illustrates a perspective view of an insufflating optical trocar in accordance with a first embodiment of the invention;

FIGS. 4(a) and 4(b) illustrate cross-sectional views of an insufflating optical trocar in accordance with another embodiment of the invention;

FIG. 5 illustrates a perspective view of a septum seal for use with the insufflating optical trocar of the invention;

FIG. 6(a)-6(d) illustrate cross-sectional views of the septum seal for use with the insufflating optical trocar of the invention;

FIGS. 7(a) and 7(b) illustrate the insufflating optical trocar and cannula of the invention;

FIGS. 8(a)-8(f) illustrate different geometric shapes and patterns of the vent hole of the invention;

FIG. 9 illustrates an insufflating needle having a transparent distal tip and insufflating vent in accordance with another embodiment of the invention;

FIG. 10 illustrates an insufflating scope having a transparent distal tip and insufflating vent in accordance with another embodiment of the invention;

FIG. 11 illustrates an insufflating scope sleeve having a transparent distal tip and insufflating vent in accordance with another embodiment of the invention;

FIGS. 12(a)-12(e) illustrate additional tip designs of an insufflating optical surgical instrument in accordance with additional aspects of the invention;

FIGS. 13(a) and 13(b) illustrate a coiled insufflating optical trocar and a coiled insufflating optical trocar with a coiled tip, respectively, in accordance with additional embodiments of the invention;

FIGS. 14(a)-14(c) illustrate flip-top or flip-tip designs of insufflating optical surgical instruments in accordance with additional embodiments of the invention;

FIGS. 15(a)-15(c) illustrate cross-sectional views of insufflating valve vents in accordance with additional embodiments of the invention;

FIG. 16 illustrates a blunt tip insufflating optical instrument having an advanceable lumen in accordance with another embodiment of the invention;

FIGS. 17(a) and 17(b) illustrate an insufflating surgical instrument including an insufflating optical trocar and a cannula having a gas channel for transferring insufflation gas to the trocar in accordance with another embodiment of the invention;

FIG. 18 illustrates an insufflating blade actuating optical trocar in accordance with another embodiment of the invention; and

FIGS. 19(a)-19(i) illustrate additional tip designs in accordance to other aspects of the invention to facilitate penetration of body tissue.

DESCRIPTION OF THE INVENTION

Referring to FIG. 1, there is shown a typical laparoscopic abdominal surgery where an inflation needle 10 is inserted through a body or abdominal wall 15 and into an abdominal cavity 25. A gas is passed through the needle 10 to create a space within the abdominal cavity 25. This procedure is referred to as insufflation. The needle 10 is referred to as an insufflation needle and the gas supply is referred to as an insufflation gas. The insufflation needle 10 is placed through the body wall 15 blindly. In other words, there is no direct visualization of the procedure from the inside of the body wall 15. As explained earlier, the current procedure may inadvertently damage organs and tissues underlying the body or abdominal wall 15 such as major blood vessels and the intestinal tract. It is not uncommon for there to be internal structures attached to the internal side of the body wall 15. This is especially so in the case of the abdominal cavity 25. Portions of the intestines, colon and bowel may be attached to the abdominal wall 15. These attachments are referred to as adhesions.

Adhesions represent a potential complication in laparoscopic surgery. This is especially the case as the procedure is

initiated using a sharp or pointed instrument such as the insufflation needle 10. The delicate internal structures that may be attached by adhesions may inadvertently be pierced by the introduction of the insufflation needle 10. This can be very serious and may go undetected for some time.

Referring to FIG. 2, the typical insufflation needle 10 comprises an elongate tubular body 12, a proximal connecting housing 14, a sharp, pointed distal tip 16 and a spring, biased internal blunt core 18 with a blunt end 24 that extends beyond the sharp distal tip 16 under the influence of an extended compression spring 20. A typical placement of the insufflation needle 10 requires a user to push the sharp distal tip 16 into the abdominal wall 15, which pushes the blunt core 18 proximally, then continues to push until the distal end 22 is through the body wall 15. At that point, the blunt end 24 moves forward and thereby protects delicate structures from being inadvertently punctured by the sharp distal tip 16 of the needle 10. The safety of such a device depends to a large extent on the design and integrity of the spring 20 since the sharp distal tip 16 remains within the established internal region or body cavity 25.

Referring to FIG. 3, there is shown a perspective view of an insufflating optical instrument or trocar 30 in accordance with a first embodiment of the invention. The insufflating optical trocar 30 is designed to separate tissue fibers during insertion through the body wall 15. The insufflating optical trocar 30 includes a shaft 34 having a lumen extending substantially along an axis between a proximal end and a distal end, a handle 35 disposed at the proximal end of the shaft 34, and a blunt tip 32 disposed at the distal end of the shaft 34. The shaft 34 of the insufflating optical trocar 30 is sized and configured for disposition within a working channel of a cannula system as described in co-pending application Bladeless Optical Obturator, which is herein incorporated by reference. With this disposition, the insufflating optical trocar 30 functions to penetrate a body or abdominal wall to provide the cannula with access across the body wall 15 and into the body cavity 25, such as the peritoneal or abdominal cavity. In one aspect of the invention, the shaft 34 and tip 32 are integrally formed of a transparent material to enable visualization of tissue during the insertion of the insufflating optical trocar 30 through the body wall 15. The insufflating optical trocar 30 is configured to enable the insertion of a conventional laparoscope, which typically includes an imaging element and fiber optic light fibers. The tip 32 further includes at least one vent hole 36, and preferably two or more vent holes one on each side of the tip 32, for the insufflation gas to transfer from the inside of the trocar 30 into the body or abdominal cavity 25. The vent hole 36 (e.g., means for expelling the fluid under pressure to insufflate the abdominal region) may be chamfered on the proximal side such that the vent hole does not core tissue as the insufflating optical trocar 30 enters through the body wall 15.

The shaft 34 includes at least one shaft vent 38 and preferably a plurality of shaft vents 38 along the axis between the proximal end and the distal end. It is appreciated that vent holes 36 and shaft vents 38 may be of any geometric shape including round, oval, square, rectangular, etc., as illustrated in FIGS. 8(a)-8(c) and may be configured in different patterns such as a waffle pattern as illustrated in FIG. 8(f). Furthermore, the tip 32 may be an open tip 180 or a non-coring tip 182 as illustrated in FIGS. 8(d) and 8(e), respectively, to allow the transfer of insufflation gas into the body cavity 25. Advantages of the shaft vents 38 include supporting a plurality of core pins during the injection molding process of the shaft 34 to provide a uniform part thickness, and allowing the insufflation gas to transfer from the inner diameter of the cannula

and seal housing into the inner diameter of the insufflating optical trocar **30** and consequently out of the vent holes **36** at tip **32**.

Referring to FIGS. **4(a)** and **4(b)**, there are shown side cross-sectional views of an insufflating optical trocar **40** in accordance with another embodiment of the invention. The insufflating optical trocar **40** includes a shaft **34b** having a lumen extending substantially along an axis between a proximal end and a distal end, and a blunt tip **32b** disposed at the distal end. The insufflating optical trocar **40** further includes at least one gas channel **42** extending along the length of the shaft **34b** to provide rapid gas transfer through the insufflating optical trocar **40** when a scope has been placed within the inner diameter. It is appreciated that there may be more than one gas channel **42** extending along the length of the shaft **34b** to provide rapid gas transfer through the trocar **40**. It is further appreciated that the gas channel **42** may be formed as a separate channel or as the same channel for inserting the scope, that is, by increasing the inner diameter of the shaft **34b** to be bigger than the diameter of the scope. More specifically, even if the scope and gas share the same channel, the gas channel **42** assures that there is sufficient cross-sectional area for the gas to travel along the side of the scope and down to the vent hole(s) **36b** even when the scope is in place.

The tip **32b** may further include a marker **46** to be used as a visible reference point. The marker **46**, together with an area indicated by reference number **44** as shown in FIG. **4A**, depict the down vent of the insufflating optical trocar **40** that transfers the gas from the gas channel **42** of the trocar **40** to the vent holes **36b** at tip **32b**. For example, as the trocar **40** is being placed through the abdominal wall **15**, at some point the tip **32b** of the trocar **40** will penetrate the peritoneum. Once the peritoneum can be seen through the tip **32b** and once the peritoneum is above the visible marker **46**, the insufflation gas can be turned on and insufflation can begin. As such, this marks the point where the vent hole **36b** is within the abdominal cavity. Once the insufflation gas has created sufficient space between the abdominal wall and the organ bed, the remainder of the insufflating optical trocar **40** including the cannula system can then be fully inserted to an operative position.

The insufflating optical trocar **40** may further include a scope stop **48** as illustrated in FIG. **4(b)** to keep a scope from being inserted into the taper of the inner diameter of the trocar **40**. The scope stop **48** may further include a ledge that further prevent the possibility of the scope from being inserted too far into the trocar and consequently block the distal portion of the gas channel **42**.

Referring to FIG. **5**, there is shown a perspective view of a septum seal **50** to be used with the insufflating optical trocar of the invention. The septum seal **50** includes a tubular body **52**, a septum ring **53** and a plurality of leaflets **54** formed by a slit **56** providing an instrument seal when a scope is inserted into the insufflating optical trocar and a zero seal when the scope is withdrawn from the trocar. In addition, the thickness of the leaflets **54** can be controlled such that a pressure release mechanism can be created and consequently allowing the leaflets **54** to invert and release pressure if the abdominal pressure within the patient undergoes a sudden spike. Referring to FIGS. **6(a)**-**6(d)**, there are shown cross-sectional views of the septum seal **50** of FIG. **5**. The septum seal **50** further includes a retaining ledge **58**, which allows the septum seal **50** to be attached to the cap or handle **35** of the insufflating optical trocar, and also serves as a sealing surface. Reference number **59** illustrates a sealing surface between the septum seal **50** and the cap or handle of the insufflating optical trocar.

The septum seal **50** may further comprise a duckbill or double duckbill valve placed distally of the leaflets **54** to further limit gas or fluid escape.

During use, the insufflating optical trocar **30** is first inserted into a seal housing **84** and cannula **70** as illustrated in FIG. **7(a)**. A conventional laparoscope **72** is then inserted into the proximal end of the insufflating optical trocar **30** and advanced to the distal end of the trocar **30**. An endoscopic video camera is attached to the proximal end of the laparoscope **72**. The trocar **30** is then axially advanced by the surgeon through the body wall **15**. As the surgeon advances the cannula **70** and trocar **30** through the body wall **15**, the surgeon can visually observe tissue of the body wall **15** as it is being separated via a video monitor, which is connected to the endoscopic video camera. The surgeon can also readily determine when the body wall **15** has been completely traversed by the trocar **30**. Once the trocar **30** has traversed the body wall **15**, the trocar **30** and laparoscope **72** may be removed which leaves the cannula **70** disposed across the body wall **15** to provide an access channel into the body cavity **25** for the insertion of laparoscopic instrumentation.

As illustrated in FIG. **7(a)**, the insufflating optical trocar **30** is designed for use with the seal housing **84** and cannula **70**. The tip **32** may be blunt and does not include any sharp edges, piercing points or blades. With this aspect of the invention, the tip **32** of the bladeless insufflating optical trocar **30** is transparent and generally hollow. This enables a clear view through the distal tip of the insufflating optical trocar **30** and increases the visibility of tissue as it is being traversed. The obturator shaft **34** with the integral tip **32** may be formed of a transparent material such as polycarbonate. The septum seal **50**, which may be formed of a material such as Kraton, silicone and the like, may be snap fitted onto the proximal end of the obturator shaft **34**. The seal housing **84** may further include a handle attachment **35** including a cannula seal, which may be formed of a plastic material such as polycarbonate, that operates to attach the trocar **30** to the cannula **70** so as to maintain axial position during insertion. The diameter of the shaft **34** can range from about 2 mm to 50 mm and is designed to fit within the seal housing **84** and cannula **70**.

Referring to FIG. **7(b)**, the cannula **70** is designed to releasably attach to the seal housing **84** via cannula seal **80a**, **80b**. As the shaft **34** is inserted into the seal housing **84** and cannula **70**, the cannula seal **80a**, **80b** passively engages the seal housing **84** and serves to axially lock the shaft **34** to the seal housing **84** and cannula **70**. To release the shaft **34** from the seal housing **84** and cannula **70**, outboard tabs on shaft **34** are depressed inwardly and the shaft **34** is then free to be slidably removed. The shaft **34** includes axial key members **37** (see FIG. **3**) at its proximal end which are designed to mate with axial keyways on the seal housing **84**. As the shaft **34** is inserted into the seal housing **84** and cannula **70**, the shaft **34** is rotated slightly to align key members **37** with the keyways and then advanced until the cannula seal **80a**, **80b** engages the seal housing **84**. The key members **37** serve to rotationally index the shaft **34** to the seal housing **84**. In another aspect, cannula **70** may further include distal cannula seal **82** formed at a distal portion of cannula **70** and shaft **34** so as to further limit gas or fluid escape.

In another aspect of the invention, the insufflating optical trocar **30** may include a laparoscope lock **86** having an elastomeric element. The addition of the elastomeric element would enhance the frictional engagement with the laparoscope **72**. An example of an elastomeric element would be a silicone O-ring sized with an inside diameter smaller than the outside diameter of the laparoscope **72**. The laparoscope lock **86** could either rotate freely to enable the laparoscope **72** to

rotate freely relative to the shaft **34** or the laparoscope lock **86** could be rotationally fixed to prevent the laparoscope **72** from rotating relative to the shaft **34**.

In another aspect of the invention, a process of placing and using the insufflating optical trocar of the invention is described. First, the skin around the area to be operated on is incised appropriately for the size of the cannula **70**. An insufflation gas line **90**, which is attached to the seal housing **84**, the insufflating optical trocar **30** and the laparoscope **72** are then inserted into the cannula **70**. At this point the gas supply is still turned off. The assembled device is then advanced through the body or abdominal wall **15** under direct vision until it is observed that just the tip **32** of the device has penetrated the peritoneal cavity. The device is then held in place and the flow of insufflation gas is begun. The gas will flow through the tip **32** and into the peritoneal cavity until the cavity is sufficiently distended by gas pressure. The surgeon then completes the insertion of the insufflating optical trocar **30** until the cannula **70** is in an appropriate or desired position. The insufflating optical trocar **30** and laparoscope **72** may then be removed. At this point, the surgeon may elect to reinsert just the laparoscope **72** through the seal housing **84** and thereby allow observation of the abdominal cavity and subsequent insertions of additional laparoscopic instrumentation.

As explained earlier, an indicator line or marker **46** as shown in FIG. **4(a)** may be located on tip **32** to be viewed by laparoscope **72** to indicate when the device has advanced far enough into the body cavity to begin insufflation. The coincidence of anatomical features with the indicator line or marker **46** may indicate the correct position to begin insufflation. The indicator line or marker **46** could be circumferential in nature and when the peritoneal layer, as it is being penetrated, forms a coincident circle with respect to the indicator line **46**, the surgeon can begin insufflating. Another method is to employ an O-ring seal **86**. Additionally, it is preferred that a zero seal be present on the trocar to prevent escape of the gas when the trocar is used to place cannulas without the laparoscope **72**. A double duckbill valve **88** would work well too for this application as would a single duckbill, a flapper valve or a slit valve.

It is appreciated that the above-described concept may be applied to any surgical instruments providing visual entry and visual insufflation, regardless of size or type of fluid transfer as further described in the following exemplary embodiments of the invention. For example, FIG. **9** illustrates an insufflating needle **190** in accordance with another aspect of the invention comprising an elongate tubular body **192** having an insufflation channel extending along an axis between a proximal end and a distal end, a transparent distal tip **194** operably attached to the distal end of the tubular body **192**, and at least one insufflating vent hole **196** formed at the distal tip **194** or tubular body **192** and being in connection with the insufflation channel. The insufflating needle **190** may further include an insufflation-controlling device **198** such as a stopcock and a sealing mechanism **200** at the proximal end of the tubular body **192**. A small diameter scope **202** may be inserted at the proximal end of the tubular body **192** and then advanced to the distal end of the tubular body **192** as the insufflating needle **190** such as an insufflating Veress needle is placed through an abdominal wall. In yet another aspect of the invention as illustrated in FIG. **10**, an insufflating scope **210** comprises an elongate body **212** having an insufflation channel **224** extending along an axis between a proximal end and a distal end, a transparent tip **214** operably attached to the distal end of the elongate body **212** and having at least one insufflating vent hole **216** being in connection with the insufflation channel

224, and a handle **218** formed at the proximal end of the elongate body **212**. The insufflating scope **210** may further include an insufflation-controlling device **220** such as a stopcock at the proximal end of the elongate body **212** or on the handle **218**. The elongate body **212** includes an optical element **222** that directs light to the tip **214** and at least one insufflation channel **224** to transfer the insufflation gas into the surgical cavity.

Referring to FIG. **11**, there is shown an insufflating scope sleeve **230** in accordance with another embodiment of the invention. The insufflating scope sleeve **230** comprises a flexible sleeve **232** having a proximal end and a distal end, a transparent tip **234** operably attached to the distal end of the flexible sleeve **232** and having at least one insufflating vent hole **236**, and a handle **238** attached to the proximal end of the flexible sleeve **232**. The insufflating sleeve **230** may further include an insufflation-controlling device **240** such as a stopcock and a sealing mechanism **242** at the proximal end of the insufflating sleeve **230**. A scope **244** may be inserted at the proximal end of the insufflating scope sleeve **230** and then advanced to the distal end of the insufflating scope sleeve **230** as the insufflating scope sleeve **230** is placed through an abdominal wall.

Referring to FIGS. **12(a)-12(e)**, there are shown additional tip designs **32o-32s** in accordance with other aspects of the invention to facilitate penetration of a body tissue. FIG. **12(a)** illustrates a spoon-shaped or asymmetric tip **32o** having at least one vent hole **36o**; FIG. **12(b)** illustrates a generally domed or conical shaped tip **32p** having plastic or metal blades **33p** along an axis of the shaft and at least one vent hole **36p**; FIG. **12(c)** illustrates a blunt tip **32q** having at least one vent hole **36q**; FIG. **12(d)** illustrates a generally domed or conical shaped tip **32r** having at least one bladed fin **33r** and at least one vent hole **36r**; and FIG. **12(e)** illustrates a generally conical shaped tip **32s** having at least one vent hole **36s** at the distal tip. It is appreciated that tips **32o**, **32p**, **32r** and **32s** have a sharp, pointed or bladed tip and/or edge to facilitate penetration of body tissue. In yet other aspects of the invention, the surface of the tip may have at least one tissue engaging raised pattern on the surface. The surface operates to facilitate insertion of the insufflating surgical instrument or optical trocar with a reduced penetration force and minimize tenting of the body wall. The surface may further facilitate separation of different layers of the body wall and provides proper alignment of the tip between the layers. In another aspect of the invention, the tip may have an outer surface extending distally to a blunt point and includes a pair of side sections separated by an intermediate section, and wherein the side sections extend from the blunt point radially outwardly with progressive positions proximally along the axis. The side sections may include a distal portion in proximity to the blunt point and a proximal portion in proximity to the tubular body, and the distal portion of the side sections being twisted radially with respect to the proximal portion of the side sections.

FIGS. **13(a)** and **13(b)** illustrate a coiled insufflating optical trocar **250** and a coiled insufflating optical trocar with a coiled tip **260**, respectively, in accordance with additional embodiments of the invention. The coiled insufflating optical trocar **250** comprises a shaft **34t** having a lumen and a hollow coiled tube or gas channel **42t** wrapped substantially along the length of the shaft **34t** to provide gas transfer into the body cavity. An advantage of this aspect of the invention is coiling also helps to keep the trocar from moving about inside a body cavity. The coiled insufflating optical trocar **250** may further include an insufflation-controlling device **240** such as a stopcock at the proximal end of the coiled insufflating optical

trocar **250**. A scope may be inserted at the proximal end of the coiled insufflating optical trocar **250** and then advanced to the distal end of the trocar **250** as the trocar **250** is placed through an abdominal wall. The coiled insufflating optical trocar with coiled tip **260** as shown in FIG. **13(b)** is similar to the coiled insufflating optical trocar **250** but further includes a tip **32u** and a hollow coiled tube or gas channel **42u** that wraps around the tip **32u** and substantially along the length of the shaft **34u**.

Referring to FIGS. **14(a)**-**14(c)**, there are shown additional tip designs **32v**-**32x** in accordance to other aspects of the invention. For example, the tip **32v** as illustrated in FIG. **14(a)** comprises a flip-top **272** and a conical body **270** that operates to move from a first, penetrating position to a second, insufflating position when the body wall has been traversed. The tip **32v** may further comprise a retention member for connecting the flip-top **272** and the conical body **270**. The retention member may be one of a spring, a spring wire, an offset hinge or a "living" hinge. Other flip-top or flip-tip designs as described in co-pending U.S. patent application Ser. No. 10/805,864, entitled "Surgical Access Port and Method of Using Same," filed Mar. 22, 2004, which is herein incorporated by reference, may also be used with the insufflating concept of the invention. In yet another aspect of the invention, the tip **32w** as illustrated in FIG. **14(b)** comprises a two-piece flip-top **282a**, **282b** that operates to move from a first, penetrating position to a second, insufflating position when the body wall has been traversed. In particular, the tip **32w** may comprise at least two or more parts or petals that reposition to the side of the shaft **34w** in the second, insufflating position. FIG. **14(c)** illustrates the tip **32x** in accordance with another aspect of the invention comprising a two-stage flip-top **290** that operates to move from a penetrating position to an insufflating position and then to an instrument access position. In particular, the two-stage flip-top **290** comprises a distal flip portion **292** and a proximal flip portion **294**. In the first stage, the distal flip portion **292** moves from a penetrating position to an open or insufflating position once the body wall has been traversed. Once insufflation has been achieved, the proximal flip portion **294** moves to an open or instrument access position in the second stage. The tip **32x** may further comprise retention members for connecting between the distal flip portion **292** and the proximal flip portion **294**, and between the proximal flip portion **294** and the shaft **34x**.

FIGS. **15(a)**-**15(c)** illustrate insulating valve vents in accordance with additional aspects of the invention. More specifically, FIG. **15(a)** illustrates an insufflating valve vent **300** formed at the distal end of the shaft **34**. The insufflating valve vent **300** is formed of an elastic material to allow gas such as CO₂ to be introduced from the inside of the shaft **34** to a body cavity. It is appreciated that when there is no gas, the elastic material of the insufflating valve vent **300** causes it to close so as to provide an airtight seal. FIG. **15(b)** illustrates an insufflating flapper valve **310** formed at tip **32y** of an insufflating optical trocar. The insufflating flapper valve **310** comprises at least one flapper valve vent **312** that operates to open when a gas such as CO₂ is introduced in the shaft **34**. It is appreciated that when there is no gas, the flapper valve vent **312** closes to provide a tight seal. Similarly to FIG. **15(b)**, FIG. **15(c)** illustrates an insufflating reverse flapper valve **320** formed at tip **32z** of an insufflating optical trocar. The insufflating reverse flapper valve **320** comprises at least one flapper valve vent **322** that remains close or shut by tissue during insertion, and once peritoneum is passed, pressure by a gas such as CO₂ would then open the reverse flapper valve **320** to allow the

transfer of the gas into a body cavity. It is appreciated that each of the above flapper valve vents may be spring loaded to operate like a Veress needle.

FIG. **16** illustrates a blunt tip insufflating optical instrument **400** in accordance with another embodiment of the invention. The blunt tip insufflating optical instrument **400** comprises an elongate tubular body **410** extending along an axis between a proximal end and a distal end, a blunt tip optical obturator or separator **420** to be inserted through the tubular body **410** and into a body cavity, and an advanceable insufflation channel **430** extending along the length of the tubular body **410** and into the body cavity. The blunt tip optical obturator or separator **420** operates to provide visibility down to the peritoneum at which time the insufflation channel **430** may be advanced through the peritoneum to provide gas and/or saline to the body cavity until sufficient space is achieved. Once gas and/or saline have been sufficiently introduced, the blunt tip optical obturator **420** and tubular body **410** may be advanced into the body cavity. A feature of this aspect of the invention is the insufflation channel **430** may be advanced ahead of the blunt tip optical obturator or separator **420** to puncture peritoneum to transfer gas such as CO₂ to the body cavity.

Referring to FIGS. **17(a)** and **17(b)**, there are shown illustrations of an insufflating surgical instrument **500** in accordance with another embodiment of the invention. The insufflating surgical instrument **500** comprises an insufflating optical trocar **502** and a cannula **520**. The insufflating optical trocar **502** comprises a shaft **504** having a lumen extending along an axis between a proximal end and a distal end, a tip **506** disposed at a distal end of the shaft, at least one vent hole **508** to introduce gas from the cannula **520** into the body or abdominal cavity as further discussed below, and a gas channel **510** formed in either the shaft **504** or the tip **506** and operably connected to the at least one vent hole **508** to allow gas transfer from the cannula **520** to the insufflating optical trocar **502**. The cannula **520** comprises at least one cannula gas channel **522** extending along its longitudinal axis to transfer gas to the trocar gas channel **510** after insertion of the insufflating optical trocar **502** into the cannula **520**. In other words, the cannula gas channel **522** is encased as a lumen in the cannula wall. During operation, the transfer of gas only takes place if there is an alignment between the cannula gas channel **522** and the trocar gas channel **510** as illustrated in FIGS. **17(a)** and **17(b)**. A scope **525** may be inserted at the proximal end of the insufflating optical trocar **502** and then advanced to the distal end of the trocar **502** as the trocar **502** is placed through an abdominal wall.

In yet another aspect of the invention, FIG. **18** illustrates an insufflating blade actuating optical instrument **600** in accordance with another embodiment of the invention. The insufflating blade actuating optical instrument **600** comprises an elongate tubular member **602** extending along a longitudinal axis between a proximal end and a distal end, an optical member **604** operably attached at the distal end of the elongate member **602**, at least one blade member **606** being longitudinally movable between deployed and nondeployed positions, an actuating mechanism **608** operably attached at the proximal end of the tubular member **602** for moving the blade member **606** between the deployed and nondeployed positions, and at least one insufflating vent **610** formed in the optical member **604** to transfer insufflation gas from outside a body cavity to inside the body cavity. A scope may be inserted at the proximal end of the insufflating blade actuating optical instrument **600** and then advanced to the distal end of the instrument **600** as the insufflating blade actuating optical instrument **600** is placed through an abdominal wall.

Referring to FIGS. 19(a)-19(i), there are shown additional tip designs 32aa-32ii in accordance to other aspects of the invention to facilitate penetration of a body tissue. Each of these tip designs includes at least one vent hole (36aa-36ii) at the distal tip to introduce insufflation gas into a body cavity. It is appreciated that some of these tips have a sharp, pointed or bladed tip and/or edge to facilitate penetration of body tissue.

It is appreciated that the above described surgical instruments and devices can be used to access not only the peritoneal cavity but can be used for preperitoneal hernia repair, retroperitoneal operations including back and kidney operations, percutaneous kidney operations, thoracic surgery and arthroscopic access. In addition to gas such as carbon dioxide, it is appreciated that other fluids such as air, water and saline can also be introduced into a body cavity with the technique of the invention. It is appreciated that operating scopes may be modified such that a lumen may be used to introduce insufflation fluid. Accordingly, it is understood that many other modifications can be made to the various disclosed embodiments without departing from the spirit and scope of the invention. For these reasons, the above description should not be construed as limiting the invention, but should be interpreted as merely exemplary embodiments.

The invention claimed is:

1. An insufflating surgical instrument adapted for movement across an abdominal wall to insufflate an abdominal region of a patient, comprising:
 - an insufflating cannula having a wall forming a first lumen extending along an axis between a proximal end and a distal end, and a first insufflation channel formed in the wall extending along the axis between the proximal end and the distal end and being adapted for connection to a source of fluid under pressure at the proximal end;
 - an insufflating trocar insertable into and removable from the insufflating cannula, the insufflating trocar having a shaft with a second lumen extending along the axis between a proximal end and a distal end, a second insufflation channel formed at the distal end and being adapted for alignment with the first insufflation channel of the cannula to expel the fluid under pressure to insufflate the abdominal region, and a tip at the distal end of the shaft; and
 - at least one vent hole formed at the tip of the trocar being in connection with the second insufflation channel of the trocar;
 - wherein the shaft and the tip of the insufflating trocar have diameters sized to enable insertion of a laparoscope;
 - a seal housing attached to the proximal end of the insufflating cannula, the seal housing containing a duckbill valve;
 - a proximal cannula seal positioned outside the first and second lumens between the seal housing and the insufflating cannula;
 - a distal cannula seal positioned at the distal end of the insufflating cannula within the first lumen between the insufflating cannula and the insufflating trocar;
 - and

an elastomeric lock placed within the second lumen on an inner periphery of the shaft of the insufflating trocar.

2. The insufflating surgical instrument of claim 1, further comprising a laparoscope insertable through an opening at the proximal end of the trocar and movable to the distal end of the trocar through the second lumen, the tip at the distal end of the trocar enclosing the distal end of the trocar and the second lumen preventing the laparoscope from extending through the distal end of the trocar.

3. The insufflating surgical instrument of claim 1 wherein the shaft of the insufflating trocar has a plurality of axial keys at the proximal end of the insufflating trocar mating with a plurality of corresponding axial keyways on the seal housing.

4. The insufflating surgical instrument of claim 1 wherein the shaft of the insufflating trocar has a plurality of vents disposed along the shaft equidistant from each other between the proximal end and the distal end of the shaft, the plurality of vents in gaseous communication with the first lumen and the second lumen defining a gaseous pathway from the first lumen to the second lumen to the at least one vent hole formed at the tip of the insufflating trocar.

5. An insufflating surgical instrument adapted for movement across an abdominal wall to insufflate an abdominal region of a patient, comprising:

- an insufflating cannula having a first lumen extending along an axis between a proximal end and a distal end and being adapted for connection to a source of fluid under pressure at the proximal end;
- an insufflating trocar insertable into and removable from the insufflating cannula, the insufflating trocar having a shaft with a second lumen extending along the axis between a proximal end and a distal end and being adapted for alignment with the first lumen of the cannula to expel the fluid under pressure to insufflate the abdominal region, and a tip at the distal end of the shaft, the shaft and the tip of the insufflating trocar having diameters sized to enable insertion of a laparoscope;
- a seal housing attached to the proximal end of the insufflating cannula, the seal housing containing a zero seal;
- a proximal cannula seal positioned outside the first and second lumens between the seal housing and the insufflating cannula; and
- a distal cannula seal positioned at the distal end of the insufflating cannula within the first lumen between the insufflating cannula and the insufflating trocar.

6. The insufflating surgical instrument of claim 5, wherein the seal housing comprises a septum seal and a plurality of leaflets forming an instrument seal in the presence of a laparoscope, and providing a zero seal in the absence of an instrument.

7. The insufflating surgical instrument of claim 6, wherein the thickness of the leaflets is formed to create a pressure release mechanism that inverts and releases pressure if the abdominal pressure within the patient undergoes a sudden spike.

* * * * *

专利名称(译)	充气光学手术器械		
公开(公告)号	US7708713	公开(公告)日	2010-05-04
申请号	US11/170567	申请日	2005-06-29
[标]申请(专利权)人(译)	应用医疗资源		
申请(专利权)人(译)	应用医疗资源CORPORATION		
当前申请(专利权)人(译)	应用医疗资源CORPORATION		
[标]发明人	ALBRECHT JEREMY J BRUSTAD JOHN R TAYLOR SCOTT V JOHNSON GARY M HILAL NABIL		
发明人	ALBRECHT, JEREMY J. BRUSTAD, JOHN R. TAYLOR, SCOTT V. JOHNSON, GARY M. HILAL, NABIL		
IPC分类号	A61M37/00 A61B17/34 A61B19/00		
CPC分类号	A61B17/3417 A61B17/3462 A61B17/3474 A61B2017/349 A61B19/5212 A61B2017/3454 A61B2017/346 A61B17/3494 A61M13/003 A61B1/06 A61B90/361 A61M2202/0007 A61M2202/02 A61M2202/0468 A61M2205/3337		
优先权	60/584302 2004-06-29 US		
其他公开文献	US20050288622A1		
外部链接	Espacenet USPTO		

摘要(译)

本发明公开了一种适于穿过腹壁移动以吹入患者腹部区域的吹入式手术器械，其包括具有沿着近端和远端之间的轴线延伸的注气通道的轴，所述注气通道适于连接到在近端压力下的流体源，在轴的远端处的尖端，以及在尖端或轴处形成的至少一个通气孔与吹气通道连接并且适于在压力下排出流体。吹气腹部。尖端和轴中的至少一个由诸如聚碳酸酯的半透明或透明材料形成，以便于腹壁和腹部区域的可视化。

