



US006602252B2

(12) **United States Patent**
Mollenauer

(10) **Patent No.:** **US 6,602,252 B2**
(45) **Date of Patent:** **Aug. 5, 2003**

(54) **COMBINED DISSECTING, CAUTERIZING,
AND STAPLING DEVICE**

(75) Inventor: **Kenneth H. Mollenauer**, Saratoga, CA
(US)

(73) Assignee: **Starion Instruments Corporation**,
Saratoga, CA (US)

(*) Notice: Subject to any disclaimer, the term of this
patent is extended or adjusted under 35
U.S.C. 154(b) by 16 days.

4,654,024 A	3/1987	Crittenden et al.	
5,443,463 A	8/1995	Stern et al.	606/51
5,445,638 A	8/1995	Rydell et al.	
5,527,313 A	6/1996	Scott et al.	606/51
5,531,744 A	7/1996	Nardella et al.	
5,624,452 A	4/1997	Yates	
5,810,811 A *	9/1998	Yates et al.	606/50
6,003,517 A *	12/1999	Sheffield et al.	128/898
6,024,741 A *	2/2000	Williamson et al.	606/40
6,202,914 B1	3/2001	Geiste et al.	

FOREIGN PATENT DOCUMENTS

(21) Appl. No.: **10/037,625**

WO WO 01/12090 2/2001 A61B/18/08

(22) Filed: **Jan. 3, 2002**

* cited by examiner

(65) **Prior Publication Data**

US 2003/0125734 A1 Jul. 3, 2003

(51) **Int. Cl.**⁷ **A61B 18/18**

(52) **U.S. Cl.** **606/46**; 606/49; 606/142;
227/175.1

(58) **Field of Search** 606/40, 41, 45,
606/46, 48-52, 142, 143; 227/175.1

Primary Examiner—Michael Peffley

(74) *Attorney, Agent, or Firm*—K. David Crockett, Esq.;
Crockett & Crockett

(57) **ABSTRACT**

A medical device for simultaneously cutting tissue with a
heating element, cauterizing the tissue with heating
elements, and stapling the tissue together.

(56) **References Cited**

U.S. PATENT DOCUMENTS

4,516,574 A 5/1985 Hewes, Jr.

11 Claims, 10 Drawing Sheets

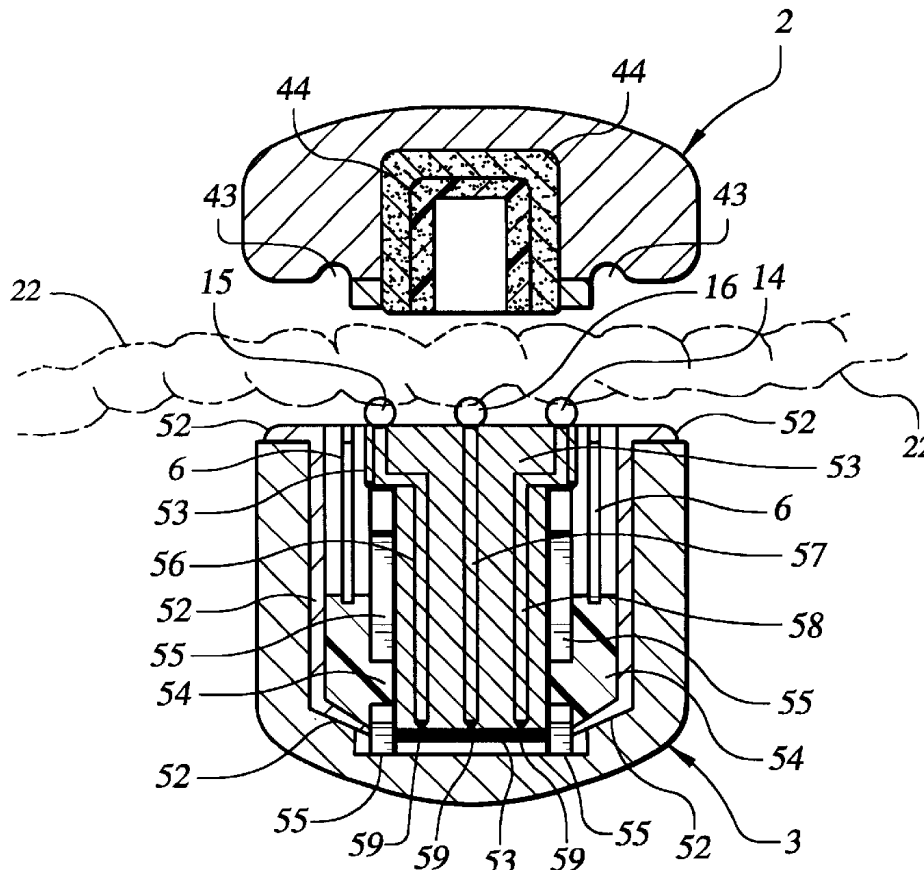

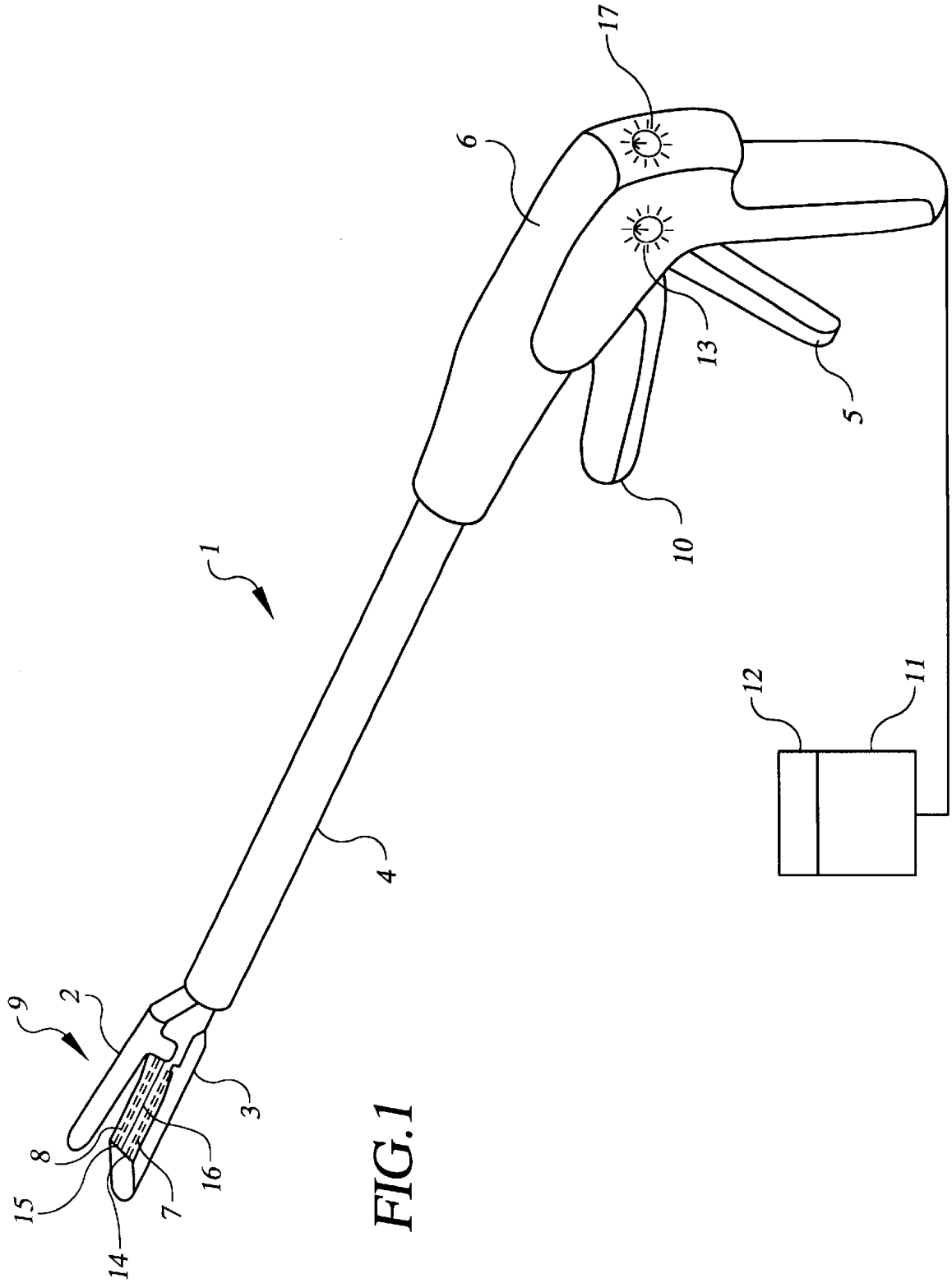

FIG. 2

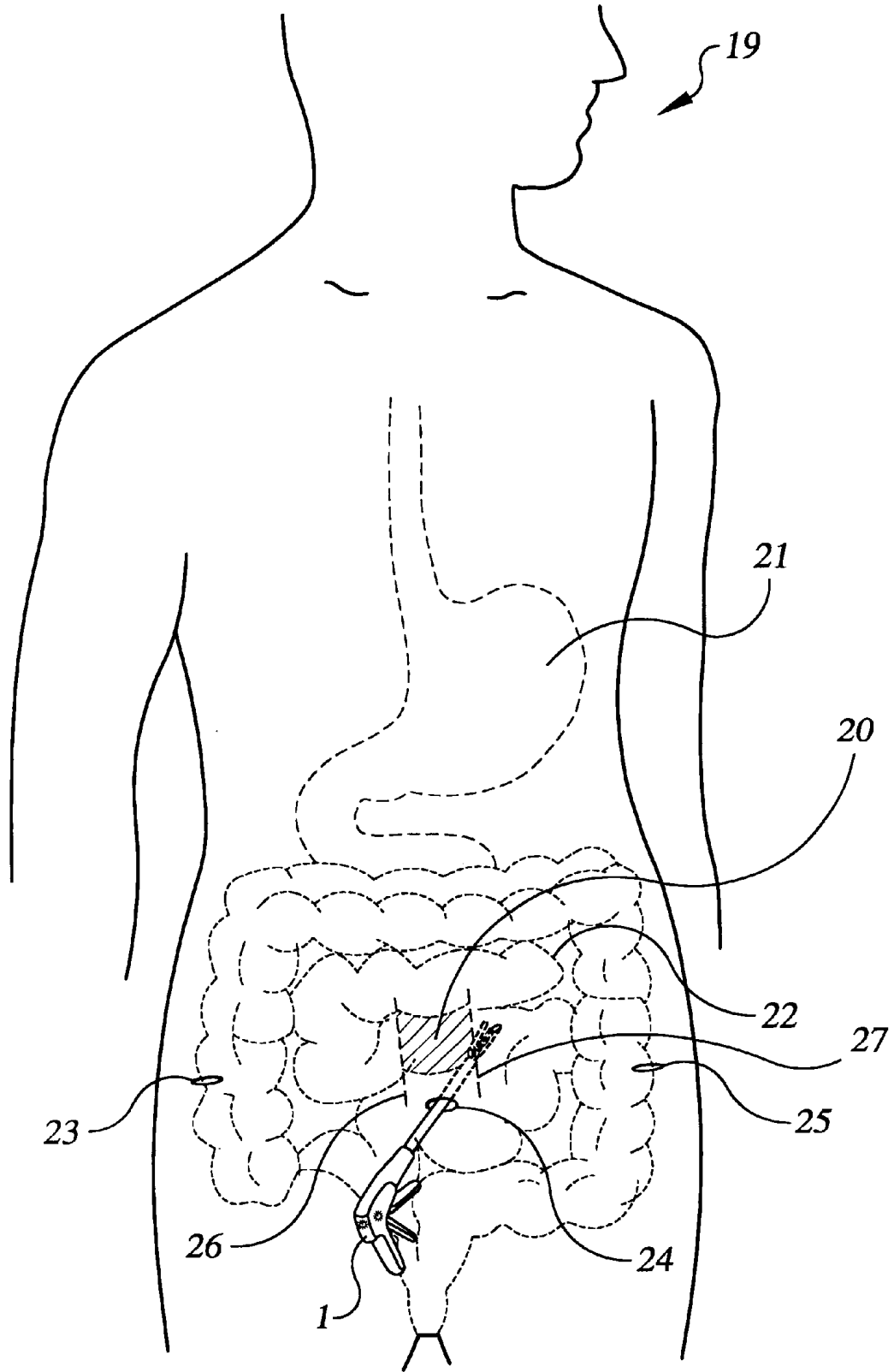

FIG. 3

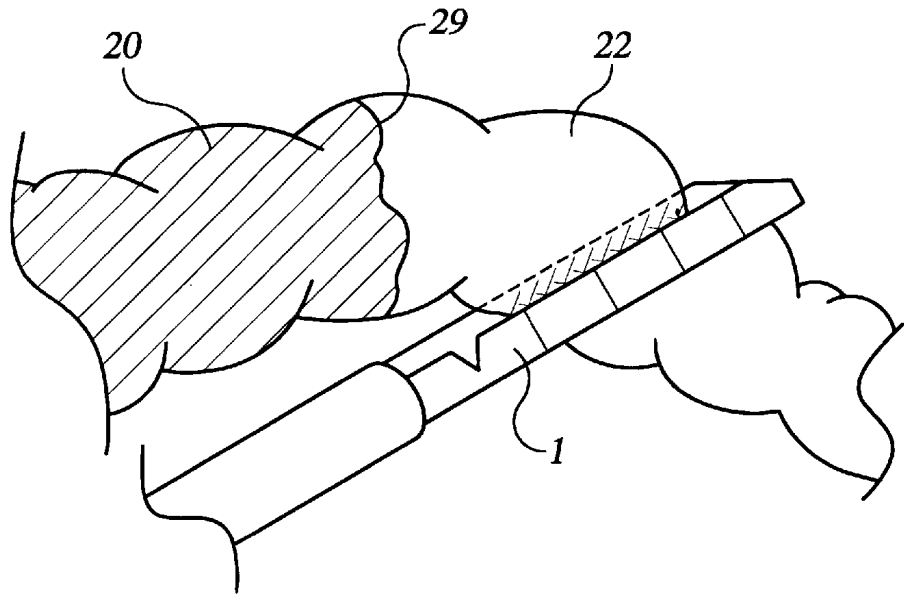

FIG. 4

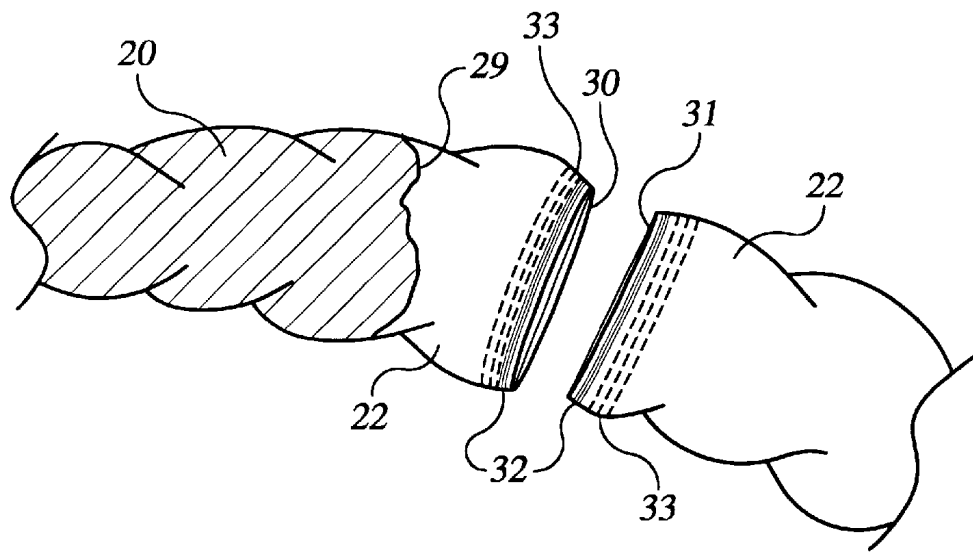

FIG. 5

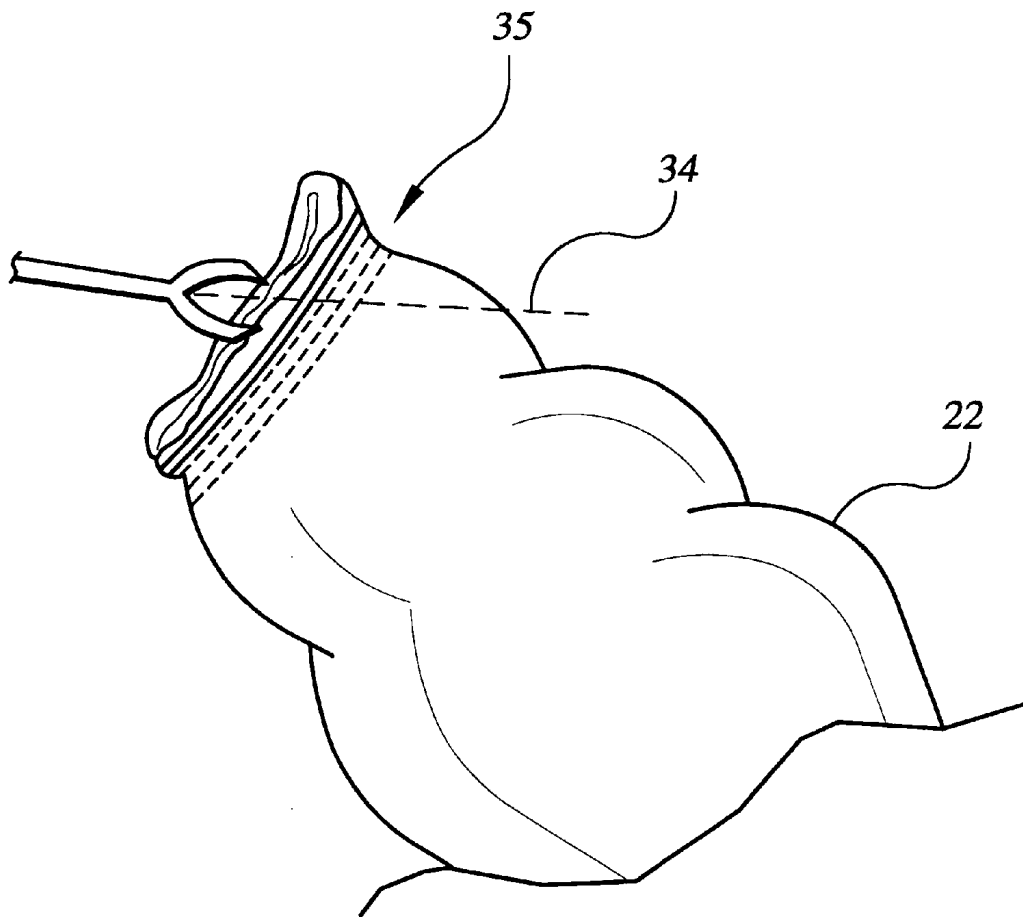

FIG. 6

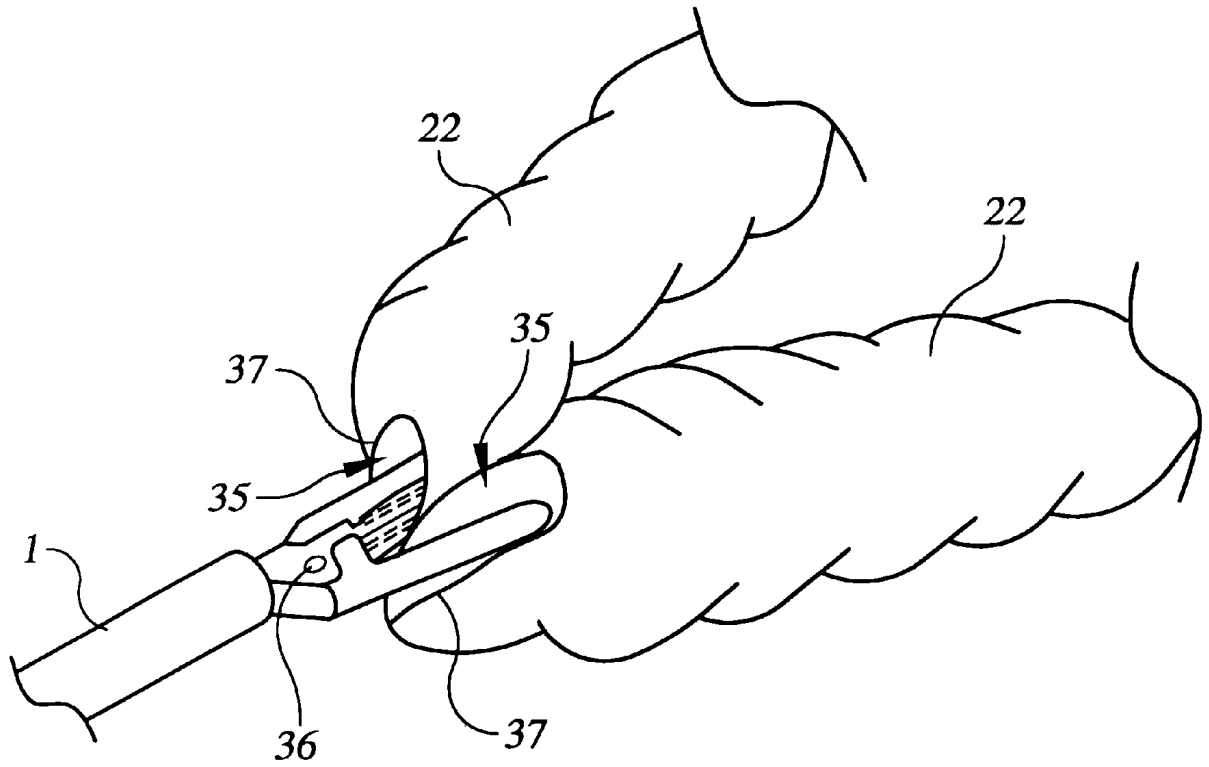

FIG. 7

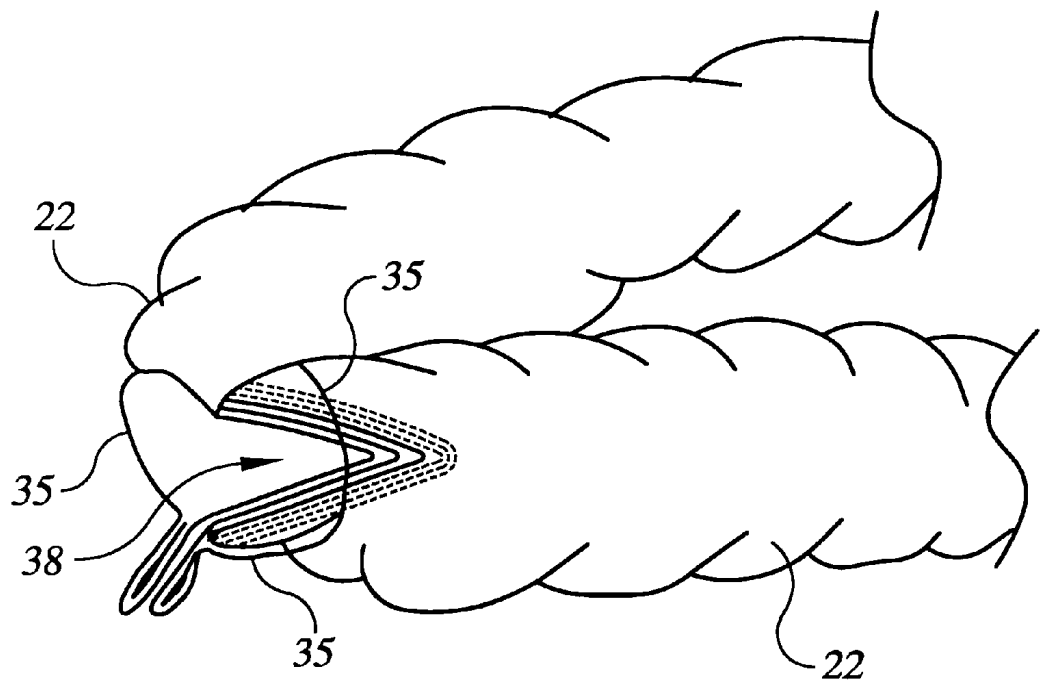

FIG. 8

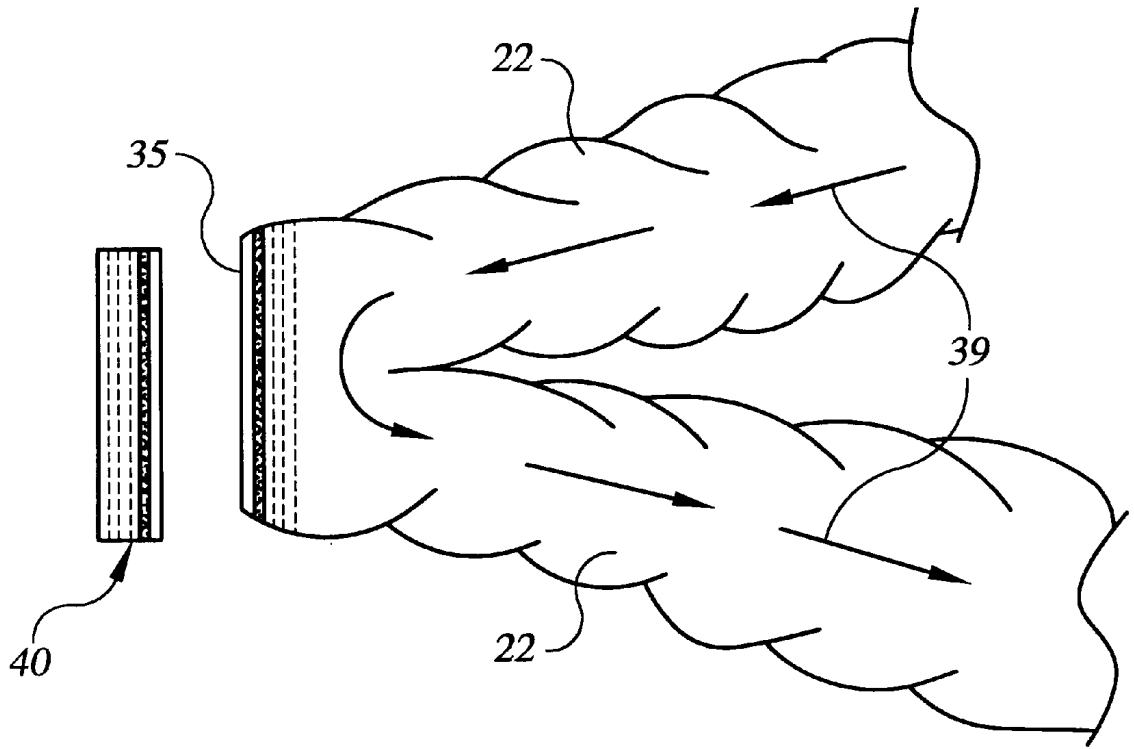
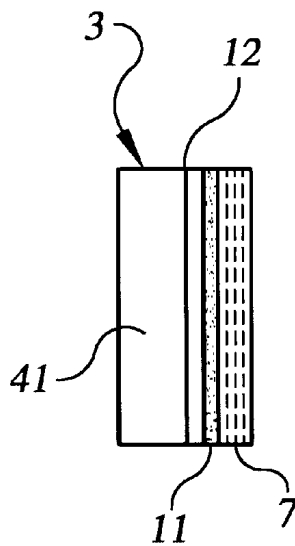

FIG. 9



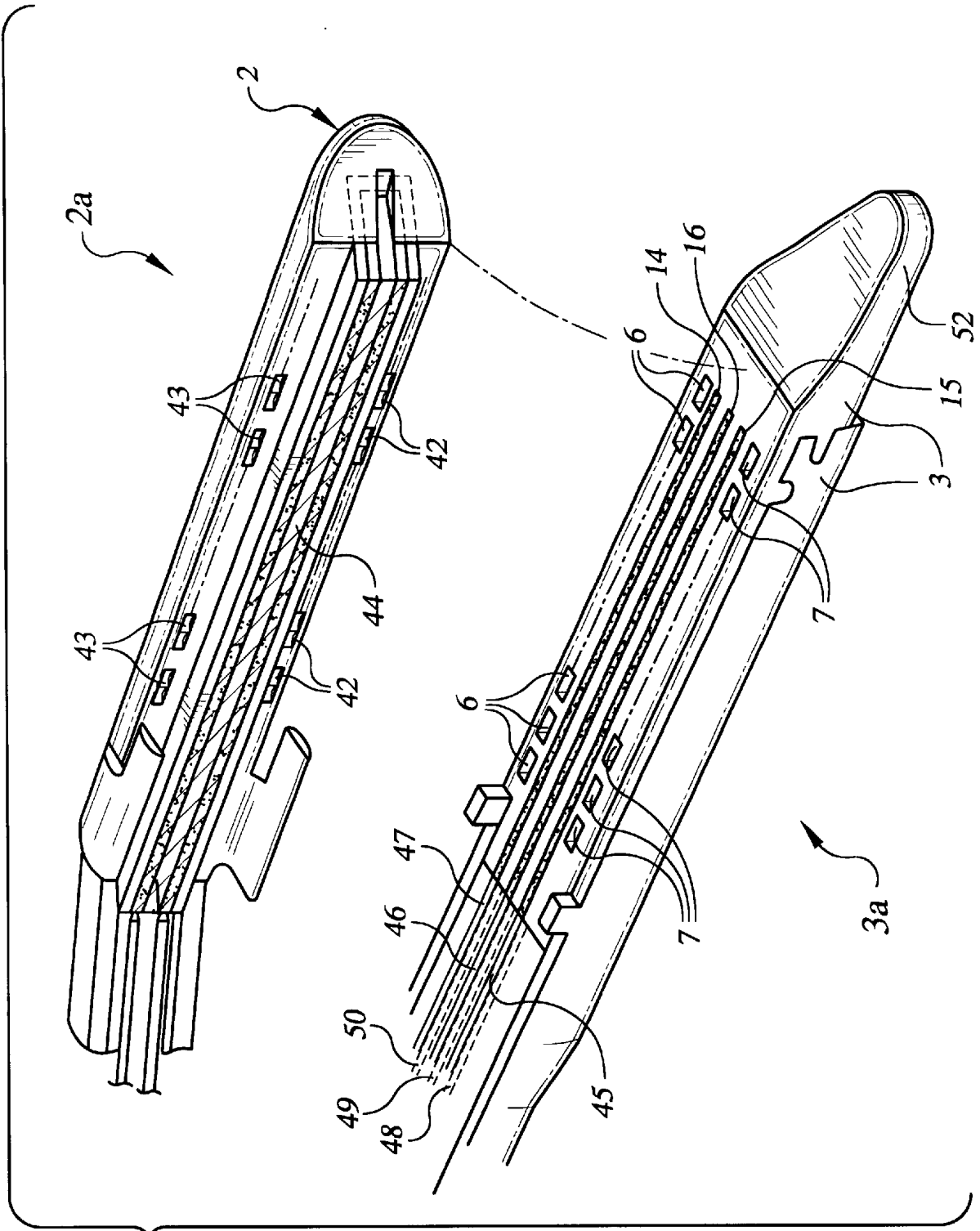

FIG. 10

FIG. 11

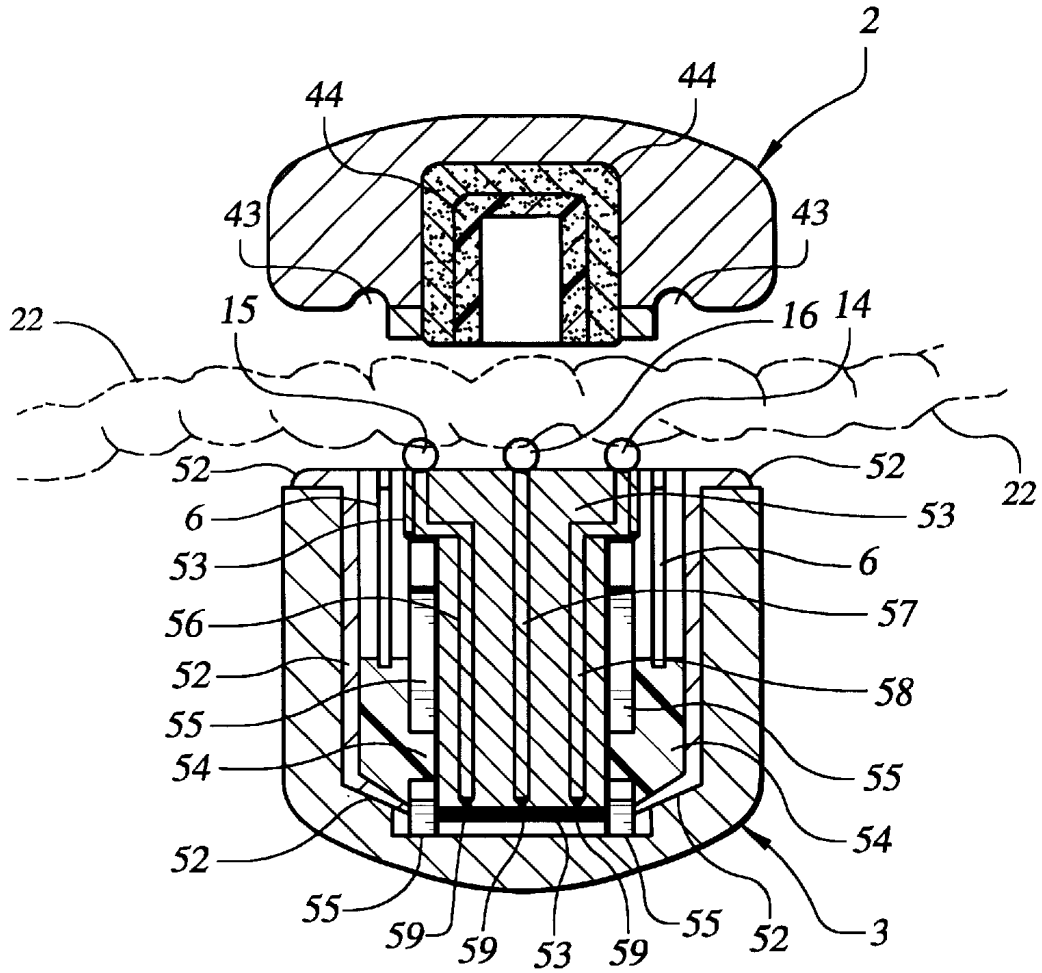

FIG. 12

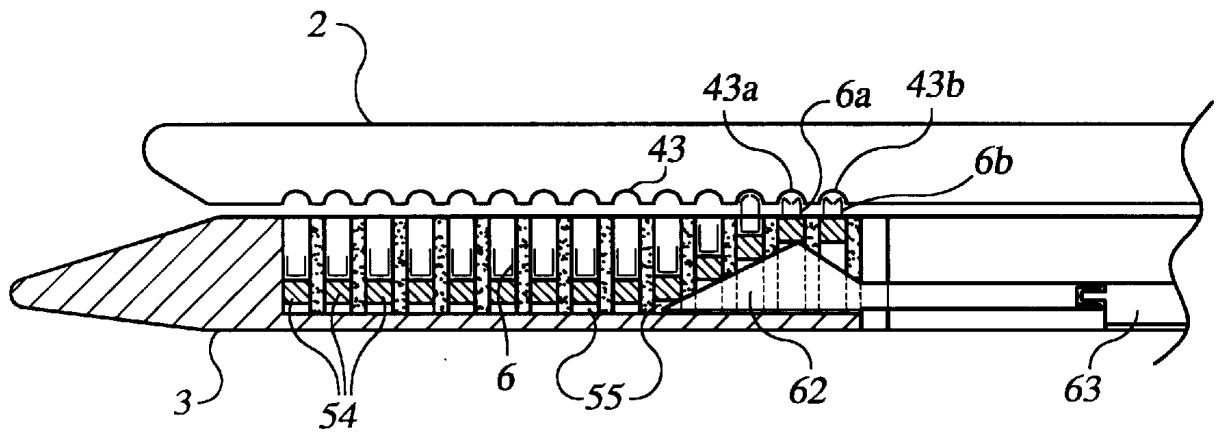

FIG. 13

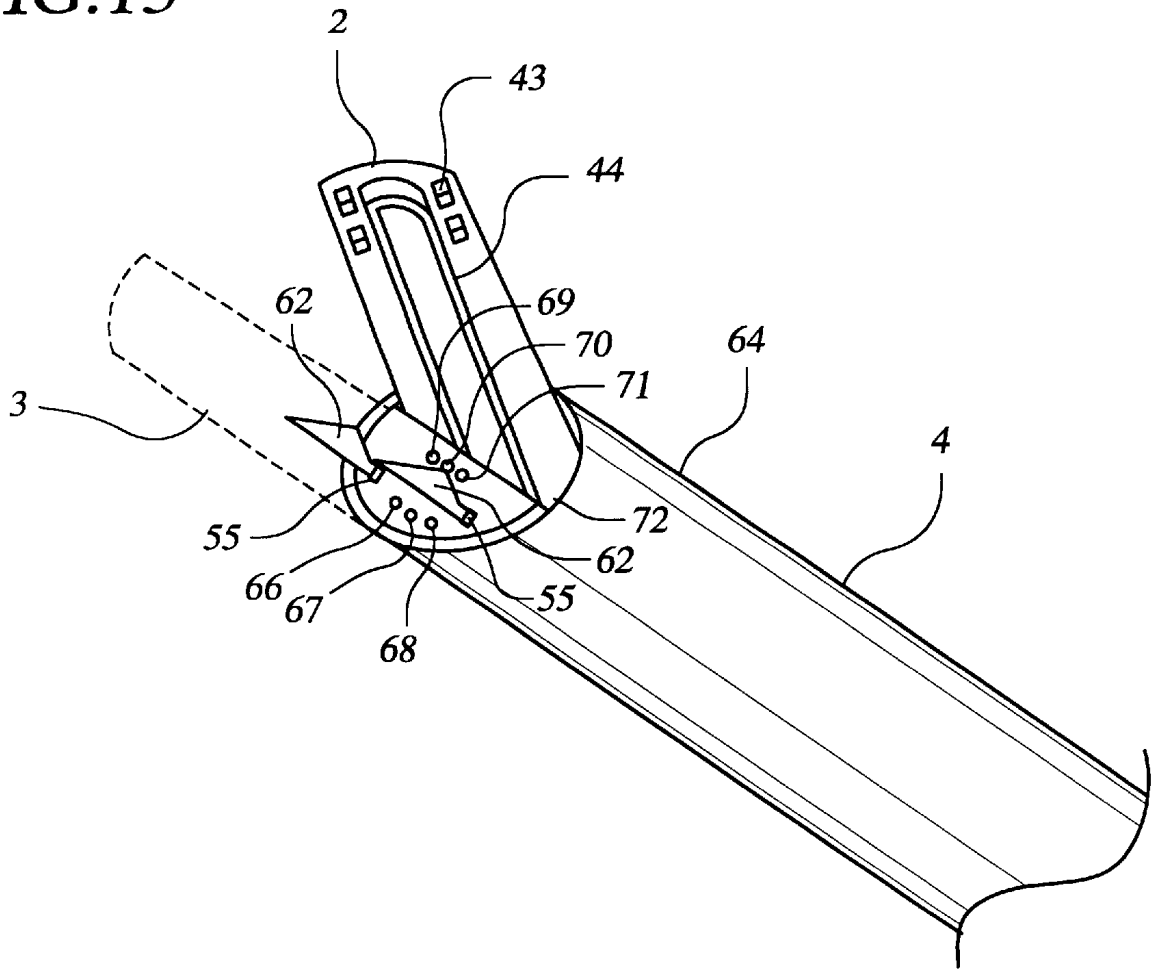

FIG. 14

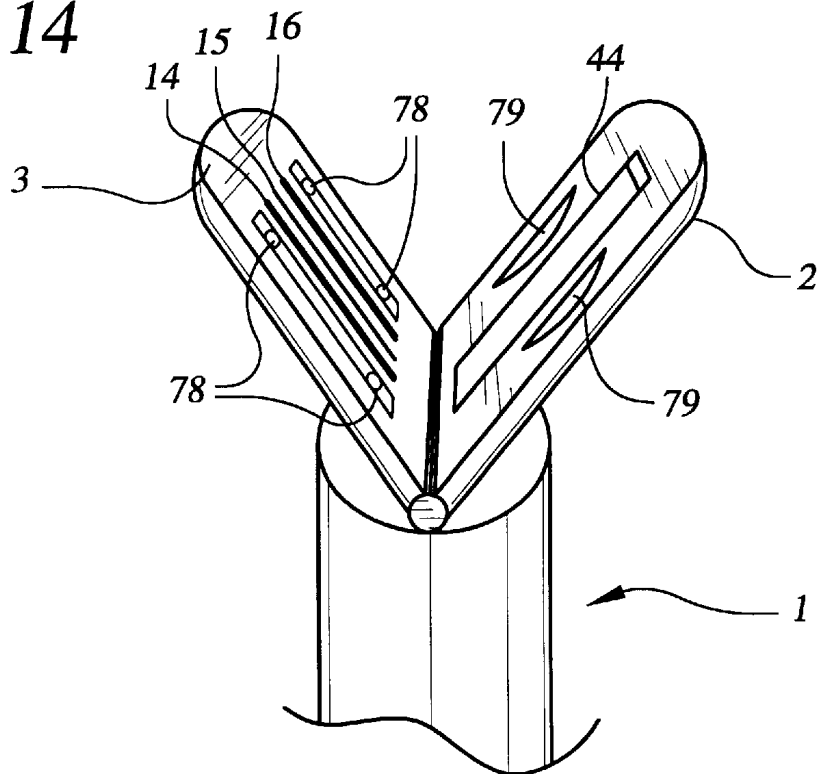
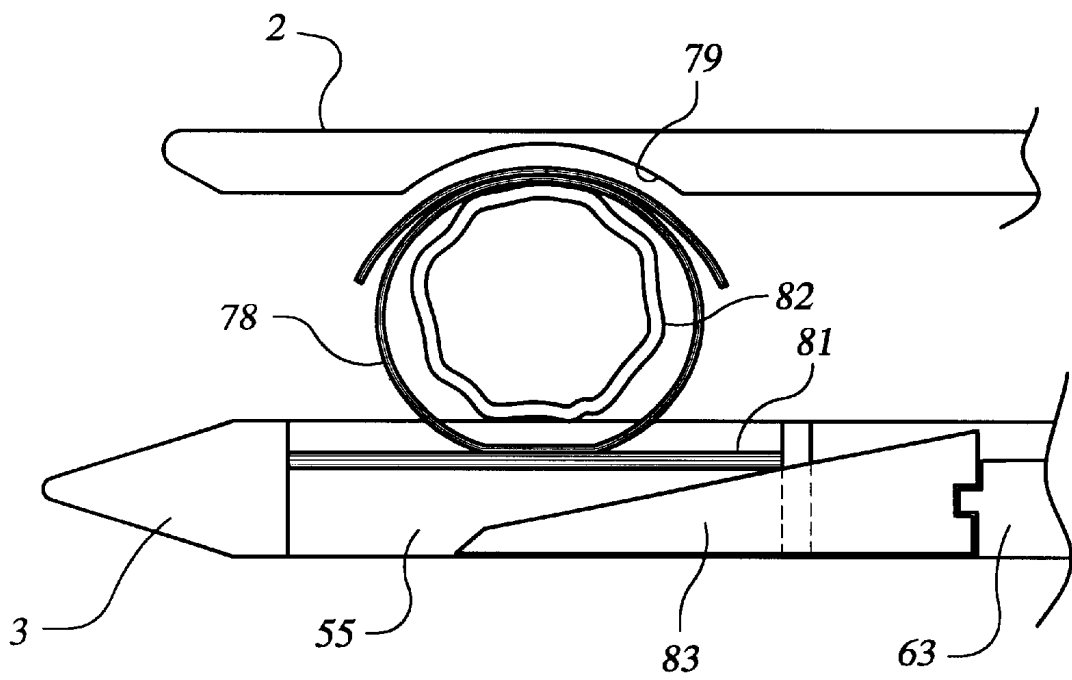

FIG. 15



COMBINED DISSECTING, CAUTERIZING, AND STAPLING DEVICE

FIELD OF THE INVENTIONS

The devices described below relate to instruments and methods for sealing, joining, and cutting tissue.

BACKGROUND OF THE INVENTIONS

Many surgical procedures require that body lumens and other tissue be cut and sealed. It is sometimes desirable to close the lumen ends with staples or clips and then to cauterize the tissue at or near the incision to prevent bleeding.

These procedures are frequently used in laparoscopic surgery. For example, one bowel resection procedure involves stapling each end of the colon closed, cutting the colon with a razor or scalpel, and then cauterizing the closed ends with heating elements. Various procedures and devices have been created to perform these tasks more efficiently.

Yates, Hemostatic Surgical Cutting or Stapling Instrument, U.S. Pat. No. 5,624,452 (Apr. 29, 1998), discloses a laparoscopic stapler that uses two rows of staples aligned parallel to each other, with each series of staples aligned parallel to its jaw members. A razor is disposed between the rows of staples, to cut the tissue, and two parallel heating elements are disposed to either side of the razor to cauterize either side of the wound.

For operations which require dividing and stapling large body vessels, such as the colon, bleeding can be greatly reduced vis-a-vis the stapler and cutter of the above references with the devices and methods disclosed below.

SUMMARY

The methods and devices described below combine a stapler, a thermal cutting element, and cauterizing elements all in the same instrument. On the outer edge of the device run parallel rows of staples oriented so that they are parallel to the length of the jaws. Inside the rows of staplers are two parallel rows of sealing elements used for cauterization. In the center is a cutting element used to separate tissue.

The combined stapler and triple-wire instrument is also referred to as a laparoscopic dissecting instrument. The laparoscopic dissecting instrument is useful for performing a variety of surgical procedures, including laparoscopic colectomies and laparoscopic appendectomies.

BRIEF DESCRIPTION OF THE DRAWINGS

FIG. 1 illustrates the overall laparoscopic dissecting instrument.

FIG. 2 shows a patient with a diseased section of colon that must be surgically removed and illustrates surgical entry points typically used in a colectomy.

FIG. 3 shows the jaws of the laparoscopic dissecting instrument performing a cut and seal procedure on a section of colon.

FIG. 4 shows the two large intestine ends cut and sealed.

FIG. 5 shows one end of the newly cut large intestine being cut again to form a new opening in the healthy intestine.

FIG. 6 shows how the two large intestine ends are joined together and then cut and sealed again.

FIG. 7 illustrates the opening made by the procedure in FIG. 5.

FIG. 8 shows how a third cut and seal closes the two large intestine ends together, allowing the flow of waste through the newly joined colon.

FIG. 9 illustrates a configuration for the grasping face of the inferior jaw that would leave no scrap when used.

FIG. 10 illustrates in detail the grasping faces of the superior and inferior jaws.

FIG. 11 shows a cross section of the superior and inferior jaws when clamped together on a section of large intestine.

FIG. 12 illustrates a cross section of the inferior jaw and superior jaw and shows the action of the actuator wedges.

FIG. 13 illustrates the distal tip of the proximal handle.

FIG. 14 illustrates the grasping faces of the superior and inferior jaws for a version of the laparoscopic dissecting instrument modified to clip smaller body lumens.

FIG. 15 illustrates a cross section of the modified instrument shown in FIG. 14.

DETAILED DESCRIPTION OF THE INVENTIONS

FIG. 1 illustrates the overall laparoscopic surgical instrument 1. On the distal end of the instrument are a first, or superior, jaw 2 and a second, or inferior, jaw 3 rotatably mounted to a rigid insertion section of rod, or tube 4, adapted for insertion into a laparoscopic work space. The jaws are also operably connected, through the insertion rod 4, to a grasping lever 5 on the proximal handle, or handle section, 6 of the instrument. When the grasping lever 5 is depressed, the superior jaw 2 will close on the inferior jaw 3 with a force proportionate to the distance the grasping lever 5 is depressed. When the grasping lever 5 is released the jaws will disengage, releasing their grip. In addition, a mechanism allows the surgeon to lock the jaws in the closed position.

Disposed within the inferior jaw 3 are two rows of staples, a left row of staples 7 and a right row of staples 8, that run parallel to the longitudinal axis of the inferior jaw 3. Each row of staples may comprise multiple rows of staples. The staples comprise standard surgical staples, though they may be surgical clips when the laparoscopic surgical instrument 1 is used for different procedures, such as ligation of blood vessels. A stapler mechanism on the stapler head 9 is operably connected to a stapler lever 10 such that when the stapler lever 10 is depressed the staples 7 are ejected from the cartridge and pushed through any body tissue proximate to the cartridge. Any tissue inside the jaws will then be stapled together.

Disposed just inside the two rows of staples 7 and 8 are two parallel rows of sealing elements used to heat or cauterize tissue. A sealing element is a heating element that can be raised to a temperature sufficient to cauterize and seal tissue. Electric current is supplied to the sealing elements from an electric current source 11 and regulated by one or more control boxes 12, all of which are operated by the surgeon. The current source 11 may be an AC to DC power converter plugged into an outlet, or may be one or more batteries. A left control dial 13, or controller, controls the temperature of a left sealing element 14 by adjusting the current flow through the left sealing element. The left control dial 13 is located on the left side of the handle 6 and is operably connected to the left sealing element 14 and to the power source 11. A right sealing element 15 is similarly connected to the current source 11. A right control dial, or controller, controls the temperature of the right sealing element 15 by adjusting the current flow through the right

sealing element. The right control dial is located on the right side of the handle **6** and is operably connected to the right sealing element **15** and to the power source **11**. Each control dial can be independently operated to control the amount of heat applied through each individual sealing element. Alternatively, the control dials may be formed with only “on” and “off” positions so that the temperature of the sealing elements remains set at a level determined by the manufacturer. The control dials may be replaced with levers, buttons, switches, or other suitable mechanisms to control how much, if any, heat is applied to the heating elements. The control mechanisms may be located on the proximal handle **6**, as shown, or on the control box **12** or current source **11**.

Disposed along the center of the grasping face of the inferior jaw **3** is a cutting element **16** used to sever tissue. A cutting element is a heating element that can be heated to a temperature sufficient to sever tissue. The cutting element **16** is operably connected to a cutting element control dial **17**, or controller, located on the back of the proximal handle **6**, and to the power source **11**. The cutting element control dial **17**, operably connected to the power source **11** and the cutting element **16**, controls the temperature of the cutting element **16**. Alternatively, the cutting element control dial may be formed with only “on” and “off” positions so that the temperature of the sealing elements remains set at a level determined by the manufacturer. The cutting element control dial **17** may be replaced with any suitable control mechanism for adjusting temperature, such as buttons, levers, or switches.

FIGS. **2** through **8** show how the surgical instrument **1** is used in a typical laparoscopic colectomy, or bowel resection. FIG. **2** shows a patient **19** with a diseased section of colon **20**, shown with hatch marks, which must be surgically removed. The stomach **21** and large intestine **22** are shown for reference to indicate their position inside the body. A surgeon begins the operation by making incisions at one or more points **23**, **24**, and **25**. One of the incisions is used to insert the laparoscopic dissecting instrument **1** into the abdomen and the other incisions are typically used to insert other devices used in the surgery. The surgeon then uses the laparoscopic dissecting instrument **1** to first cut and then remove the diseased section of colon from the body. Dashed lines **26** and **27** show where the surgeon cuts the colon to remove the diseased portion **20**.

FIG. **3** shows the jaws of the laparoscopic dissecting instrument **1** performing a cut and seal procedure on a section of colon **22** at cut line **27** of FIG. **2**. As shown in FIG. **3**, the instrument **1** firmly grasps the colon at a point relatively far from the section of diseased colon **20**, which is shown with hatch marks beginning at demarcation line **29**. The left and right sealing elements are heated to the point where the tissue is cauterized to prevent bleeding and leakage of fluids. Typically, the left and right sealing elements are heated to a temperature range of 45° to 99° Celsius. However, due to significant heat transfer losses the sealing elements may be operated above 99° Celsius so that the tissue experiences a temperature of about 95° to 99° Celsius. At those temperatures the tissue is cauterized and sealed fairly quickly, over a few seconds, but not severed.

After heat sealing, the staples are fired to seal off the two sections of colon. Alternatively, the staples are fired at the same time the tissue is heat sealed. Next, the cutting element is elevated to a temperature high enough to cause the tissue to separate, thus severing the two sections of colon. Alternatively, the staples are fired and the tissue heat sealed simultaneously with cutting. Typically, the cutting element

is heated to a temperature over 100° Celsius. However, the cutting element is usually not operated at extremely high temperatures, more than several hundred degrees Celsius, because of the possibility of damage to surrounding tissue or to the instrument.

FIG. **4** shows the two large intestine **22** ends after the cut and seal procedure. The left dissected edge **30** and right dissected edge **31** have been cauterized by the cutting action of the cutting element. Just inside the wounds are bands of cauterized tissue **32**, placed there by the left and right sealing elements. These bands of cauterized tissue seal the colon's anterior and posterior sides together, prevent bleeding, and assist in preventing waste from leaking out of the colon. Proximal to the bands of cauterized tissue **32** are three rows of surgical staples **33** that provide most of the securing force necessary to keep the colon sealed permanently. Each row of staples is slightly offset from the other. Note that additional rows of staples can be made by firing the stapler multiple times or by providing a stapler with more rows of staples.

The procedure shown in FIGS. **3** and **4** is repeated on the other side of the section of diseased colon **20** along cut line **26**. The diseased section of colon **20** is then removed from the patient **19**. Subsequently, the two remaining healthy sections of colon are joined together to restore the flow of waste, as shown in FIGS. **5** through **8**.

FIG. **5** shows one end of the newly cut large intestine **22** being cut again to form a new opening in the healthy intestine. The surgeon cuts along line **34** with a standard laparoscopic cutting instrument, resulting in a diagonal opening **35** in the intestine. This procedure is repeated with the other intestine end.

FIG. **6** shows how the two large intestine ends are next joined together and then cut and sealed again. The two sections of colon **22** are brought together, with their open ends **35** placed next to each other as shown. The jaws of the laparoscopic dissecting instrument **1** then grip the walls of the two sections of colon such that the proximal end of the jaws **36** is placed at the edges **37** of the open colon sections. Thus, a portion of each colon section is trapped between the jaws. The jaws are then closed, the tissue cauterized, the staples fired, and the tissue cut as described above.

FIG. **7** illustrates the opening made by the procedure in FIG. **6**. The cut and seal procedure leaves a “V” shaped wound **38** that creates a passage between the walls of the two sections of colon **22**. The passage **38** is large enough to allow waste to flow between the two sections of colon.

FIG. **8** shows how a third cut and seal closes the two large intestine **22** ends together. The open ends of the colon section **35** shown in FIG. **6** are clamped together with the jaws of the laparoscopic instrument. Then the seal, staple, and cut procedures are repeated. The result is that both colon ends are sealed together, creating a passage through which waste can flow (as shown by arrows **39**). Note that a scrap of colon tissue **40** remains after this step, which is removed and discarded once the colon sections have been successfully joined.

FIG. **9** illustrates a configuration for the grasping face of the inferior jaw **3** which would leave no scrap when used in a procedure different than that shown in FIGS. **2** through **8**. In this configuration, the left side **41** of the grasping face is devoid of sealing elements and staples (such as those shown in FIG. **1**). Thus, no scrap remains when the right sealing element **15**, right row of staples **8**, and the cutting element **16** are used on the ends of the colon shown in FIG. **7**. Alternatively, the same result can be obtained by using the grasping face configuration shown in FIG. **1**. In this case, the

surgeon fires only one set of rows of staples and uses only the sealing element next to that set of rows of staples to seal the tissue.

In addition to the configuration of staple rows, sealing elements, and cutting element shown in FIG. 9, other configurations are possible. For example, the inferior jaw 3 may be designed with opposite symmetry such that the sealing element and staples are on the left side of the cutting element 16. In another example, the placement of the heating elements and staple rows may be asymmetrical if advantageous for a particular technique.

FIG. 10 illustrates the stapling head of FIG. 1 in detail, with the superior and inferior jaws laid open relative to each other for clear illustration of detail. The stapling head comprises the first grasping face 2a, or the grasping face of the superior jaw 2 and a second grasping face 2b, or the grasping face of the inferior jaw 3. Along the right and left sides of the grasping face of the inferior jaw 3 lie two rows of staples, a left row of staples 7 and a right row of staples 8. Each row of staples comprises a series of staples oriented along the longitudinal axis of the inferior jaw 3. Each staple is comprised of a typical surgical staple. Although only two rows of staples are shown in FIG. 10, the inferior jaw 3 could easily be made wider to accommodate more rows of staples. Typically about 2 to 8 rows of staples are provided, with matching numbers of rows of staples located on either side of the inferior jaw 3. For convenience during manufacture or use, the staples may be disposed within a cartridge 52 which is further disposed in the trough-like body of the inferior jaw. This cartridge may be first loaded with staples, then inserted into the jaw. If a re-usable device is desired, the cartridge may be removably attachable into the inferior jaw, so that surgeons can discharge staples to establish a joint, remove the device from the laparoscopic worksite, remove the spent cartridge and replace it with a new, loaded cartridge. If a disposable device is desired, the cartridge may be fixedly attached to the inferior jaw, or the jaw may be fabricated without a distinct cartridge (that is, the cartridge may be formed integrally with the jaw).

Along the right and left sides of the grasping face of the superior jaw 2 lay two rows of staple anvils, a right row of anvils 42 and a left row of anvils 43, comprising typical dimpled staple anvils. Each anvil is oriented along the longitudinal axis of the superior jaw 2 and aligned to match the rows of staples 7 and 8. Although only two rows of staple anvils are shown on either side of the superior jaw 2, the superior jaw could easily be made wider to accommodate more rows of staple anvils. Typically about 2 to 8 rows of staple anvils are provided, with matching numbers of rows of staple anvils located on either side of the superior jaw 2.

Disposed just inside the two rows of staples 7 and 8 on the inferior jaw 3 are two parallel rows of sealing elements, or electrically resistive wires, used to cauterize tissue. The sealing elements generally lie along the long axis of the stapler head 9, though radially offset from the long axis. The left sealing element 14 is operably connected to the power source 11 and to the left control dial 13. A right sealing element 15 is similarly connected to the power source 11 and the right control dial. To ensure that tissue is not cut when it should be sealed, both sealing elements are operably connected to the control box 12 so that neither element can heat up to a temperature exceeding a point predetermined by the manufacturer. The predetermined maximum temperature is about 99° Celsius to about 105° Celsius. The exact temperature depends on the intended application of the device, though the tissue to be sealed should not exceed a temperature of 99° Celsius.

Both sealing elements are comprised of a non-stick material with a positive temperature coefficient, such as a NiCr alloy, NiTi alloy, carbon, stainless steel, or other suitable elements and alloys available from vendors such as Wiretron. The width of the sealing elements is from about 0.008" to about 0.020". For devices intended for colectomy, the sealing elements comprise nichrome and are typically about 0.010" to about 0.012" wide.

Disposed along the long axis, or center, of the grasping face of the inferior jaw is a cutting element 16, or electrically resistive wire, used to sever tissue. The width of the cutting element is about 0.008" to about 0.020", depending on the application, and is made of the same materials as the sealing elements. For devices intended for colectomies the cutting element is typically about 0.010" wide to about 0.012" wide. The cutting element 16 is operably connected to the power source 11 and a control dial 17 that controls the temperature of the cutting element 16. The temperature of the cutting element 16 is designed to operate at a temperature of about 100° Celsius to several hundred degrees Celsius. However, to prevent damage to the device and to surrounding tissue, an electrical control mechanism prevents the temperature of the cutting element 16 from exceeding about 580° Celsius.

For all three heating elements the temperature is measured with thermocouples or thermistors disposed in proximity to the heating elements, and the heating elements are controlled by adjusting the current flow or voltage through the elements in response to the measured temperature of the elements. Alternatively, other measurement schemes could be used, such as measuring the radiant heat from the elements or measuring the temperature of the grasping face proximate the heating elements, or directly measuring the temperature of the tissue trapped between the jaws during use.

Located in the center of the grasping face of the superior jaw 2, and sized to accommodate all three heating elements 14, 15, and 16, is a resilient anvil 44 that runs along the 10 longitudinal axis of the superior jaw 2. The resilient anvil 44 is made of a substantially resilient, non-stick material that is thermally resistant. Suitable materials include polytrafluoroethylene (PTFE) (available as Teflon®), graphite, Kapton®, mica, or silicone. The resilient anvil 44 evens out pressure against tissue and insulates the superior jaw 2 electrically and thermally. The anvil 44 also prevents heat dissipation and focuses heat from the three heating elements on specific areas of tissue, thus helping to prevent damage to surrounding tissues. However, within the local area of the sealing or cutting elements, the resilient anvil 44 helps to spread heat evenly on the tissue intended to be cut or sealed. In addition, the resilient anvil 44 may incorporate thermally reflective material as layers or coatings. Useful reflecting materials include ceramics, thermally reflective metals, and thermally reflective polymers, such as Mylar® polymeric compositions. By insulating and reflecting the heat generated by the heating elements, the coated resilient anvil 44 minimizes power consumption and further limits heating of surrounding tissue.

At the proximal end of the inferior jaw 3 are a right power conductor 45, a middle power conductor 46, and a left power conductor 47 that conduct electrical power from the power source 11 to the three heating elements, 14, 15, and 16. Inferior to the power conductors, shown in shadow, are a right ground wire 48, a middle ground wire 49, and a left ground wire 50 that connect the heating elements to ground.

FIG. 11 shows a cross section of the superior jaw 2 and inferior jaw 3 clamped together on a section of large

intestine 22. The cross section is taken at the point where the three heating elements terminate at the distal end of the inferior jaw 3. For reference, the resilient anvil 44 and the staple anvils 43 are shown in cross section. Also visible from this perspective is a cartridge 52, which fits snugly into the inferior jaw 3.

The cartridge 52 comprises a heating element support 53, that is an integral part of the cartridge; two rows of staple drivers 54, which are operably disposed within actuator wedge channels 55; a series of staples 7 disposed superior to the staple drivers 54; and the three heating elements 14, 15, and 16, which are securely attached to the superior side of the heating element support 54. If provided in releasably attachable form, the cartridge 53 allows the staples 7 and heating elements 14, 15, and 16 to be easily replaced after the surgeon uses the cartridge 52. The surgeon simply removes the laparoscopic dissecting instrument from the patient and replaces the used cartridge with a fresh cartridge. Each fresh cartridge is loaded with staples and carries new heating elements.

The heating element support 53 is made of a thermal insulator but, unlike the resilient anvil 44, the heating element support 53 is made from a relatively hard substance so that the three heating elements are supported when the jaws, 2 and 3, grip tissue. The heating element support 53 is made from polyamide coated with non-stick Teflon® backed by steel, carbon, ceramics, mica, Teflon®, fiberglass composite, Kevlar® composite, or other non-electrically insulating material with a high dielectric constant. The heating element support 53 is sized and proportioned to be at the same height as the inferior jaw when the cartridge is fully inserted. Thus, the jaws can maintain a tight grip when closed. In alternate configurations, the heating element support 53 may be disposed higher than the grasping face of the lower jaw to accommodate bulky tissue.

The three heating elements are electrically connected to ground wires. Each heating element 14, 15, and 16 is respectively electrically connected to the right ground wire 56, the central ground wire 57, and the left ground wire 58. Ground is conducted through wires 56, 57, and 58, which pass through cartridge along channels 59 in the inferior portion of the heating element support, across the contacts in the inferior jaw 3 to ground wires 48, 49, and 50 running through the laparoscopic dissecting instrument 1, and ultimately to the power supply 11.

The heating elements are placed in electrical contact with the conducting wires whenever a cartridge is inserted into the inferior jaw 3. Likewise, the ground wires in the cartridge are placed in electrical contact with the insulated ground wires 48, 49, and 50 whenever a cartridge is inserted into the inferior jaw 3.

FIG. 12 illustrates a cross section of the inferior jaw 3 and superior jaw 2 and shows the action of the actuator wedges 62. The actuator wedges 62 are operably connected to the stapler lever 10 by a drive rod 63. When stapler lever 10 is depressed the drive rod 63 forces the actuator wedges 62 into the actuator wedge channels 55. As the actuator wedges 62 enter the channels 55 the actuator wedges force each succeeding staple driver 54 towards the staple openings. This, in turn, causes the staples 7 to drive in succession through the tissue of the colon and into the staple anvils 43 of the superior jaw 2. The staples then deform under pressure, molded by the anvils to grasp the colon tissue. The process is illustrated by staples 6a and 6b being molded into anvils 43a and 43b. The result is that the staples join the two sides of the colon together, just as one would staple two pieces of paper together.

FIG. 13 shows a view of the distal tip 64 of the proximal handle 6 and the grasping face of the superior jaw 2. The staple anvils 43 and resilient anvil 44 are shown for reference. In this view, the inferior jaw 3 is shown in shadow in order to illustrate the actuator wedges 62 and electrical contacts. To facilitate the ease of snapping the disposable cartridge 52 into the inferior jaw 3, the actuator wedges 62 can be fully withdrawn into the wedge channel 55 unless the stapler lever 10 is depressed.

Also shown in FIG. 13 are a set of electrical ground contacts, comprising a right ground contact 66, a central ground contact 67, and a left ground contact 68. Each of these contacts are placed respectively in contact with the ground wires 45, 46, and 47 when the disposable cartridge is inserted into the inferior jaw. Likewise, the electrical power contacts comprise a right power contact 69, a central power contact 70, and a left power contact 71. Each of these contacts are placed respectively in contact with heating elements 14, 15, and 16 when the disposable cartridge is inserted into the inferior jaw.

Typically, the inferior jaw 3 is a permanent part of the distal tip 64 of the laparoscopic dissecting instrument 1 and the disposable cartridge 52 is removably attached to a channel formed in the inferior jaw 3. However, from the perspective in FIG. 11 one can see that the entire inferior jaw may be modified to be removably attached to the distal tip 64 of the instrument 1. Thus, the entire inferior jaw 3 would comprise the disposable cartridge. In this case the distal end of the instrument is fitted with a cartridge channel 72. The cartridge channel has a securing means such that the inferior jaw may be removably, but securely snapped into place. The electrical contacts and actuator wedge channels 55 of the inferior jaw would align with the distal tip 64 of the instrument to allow operation of the device.

FIG. 14 illustrates the grasping faces of the superior jaw 2 and inferior jaw 3 of a version of the laparoscopic dissecting instrument 1 modified to clip smaller body lumens. The resilient anvil 44, left 14 sealing element, right sealing element 15, and cutting element 16 are shown for reference. Clips 78 replace the staples and the entire instrument 1 is sized appropriately for a targeted lumen, typically a blood lumen. The superior jaw 2 is modified so that the two rows of staple anvils comprise two rounded anvils 79. As with the stapling instrument, the width of the jaws may be increased to accommodate additional clips and clip anvils. Typically one to three clips and clip anvils are provided on each side of the heating elements. The adapted laparoscopic dissecting instrument 1 may be used with a variety of surgical techniques where blood lumens are ligated and cut. Example techniques include vein harvest, the Linton procedure, renal artery surgery, liver surgery, and splenectomies.

FIG. 15 illustrates a cross-section of the modified laparoscopic dissecting instrument 1 being used to clip a blood lumen. The principal of operation is the same as with the stapling instrument. The inferior jaw 3 is modified so that it contains only two clips 78 and two parallel clip drivers 81. The lumen 82 to be cut and sealed is placed between the two clip ends and then the stapler lever 10 is depressed. Depressing the stapler lever 10 causes the drive rod 63 to force modified actuator wedges 83 into the wedge channels 55. The actuator wedges 83 drive the clip drivers 81 upwards. In turn, the clip drivers force the two clips 78 into the anvils 79 such that the clips will deform to squeeze and seal off the lumen 82. Afterwards, the lumen is thermally sealed and cut as described above for sealing and cutting the colon.

While the preferred embodiments of the devices and methods have been described in reference to the environ-

ment in which they were developed, they are merely illustrative of the principles of the inventions. While the colectomy operation serves to illustrate the devices and methods which may be accomplished with the devices, many other surgical procedures may be accomplished with the device, such as laparoscopic appendectomy (for transection of the appendix), laparoscopic cholecystectomy (gall bladder removal), laparoscopic esophagectomy, laparoscopic splenectomy (for transection of the splenic hilum), hysterectomies, umbilical cord separation and various laparoscopic biopsies and artery transections and dissections. Thus various lumens of the body may be dissected and ligated with the devices, and various organs, when disease or trauma requires, may be removed with the devices. Other embodiments and configurations may be devised without departing from the spirit of the inventions and the scope of the appended claims.

I claim:

1. A device for cutting and sealing body tissue comprising:

an insertion rod;

a first jaw and a second jaw extending from the insertion rod, said first and second jaws being operable to allow closure of the first and second jaws relative to each other, said first jaw having a first grasping face and said second jaw having a second grasping face, said first grasping face and said second grasping face aligned to meet each other upon closure of the first and second jaws;

a cartridge disposed inside the second jaw, said cartridge comprising:

a heating element support disposed in the cartridge;

a first heating element disposed on the heating element support along a longitudinal axis;

a second heating element disposed on the heating element support, said second heating element laterally spaced from, and parallel to, the first heating element;

a third heating element disposed on the heating element support, and further disposed opposite the second heating element;

a first row of staples disposed within the cartridge, said first row of staples laterally spaced from, and parallel to, the first heating element; and

a second row of staples disposed within the cartridge, and further disposed opposite the first row of staples.

2. A laparoscopic cutting and stapling device for use within a laparoscopic work space, said cutting and stapling device comprising:

a laparoscopic stapling device having a rigid insertion section characterized by a distal end adapted for insertion into a laparoscopic work space and a proximal end, and defining a long axis of the device, a handle section mounted on the proximal end of the rigid insertion section, and a stapling head comprising a first jaw and a second jaw, wherein said first jaw has a first grasping face and said second jaw has a second grasping face, and the first and second jaws are operable to close relative to each other to bring the first and second grasping faces into opposing relationship to each other;

a cartridge containing a first row of staples disposed within the first jaw, said cartridge being operable from the handle to eject the staples from the cartridge into body tissue, said first row of staples being arranged generally parallel to the long axis of the device and radially offset from the long axis of the device;

a first heating element comprising an electrically resistive wire disposed over the first grasping face, parallel to the long axis of the device, in the center of the grasping face;

a second heating element comprising an electrically resistive wire disposed over the first grasping face, parallel to the long axis of the device, radially offset from the long axis of the device;

an electric current source operably connected to the first heating element and the second heating element;

a first controller operable to control current to the first heating element to heat the first heating element to temperatures sufficient to sever body tissue; and

a second controller operable to control current to the second heating element to heat the second heating element to temperatures sufficient to seal body tissue.

3. The cutting and stapling device of claim 2 wherein the second heating element is disposed between the first heating element and the row of staples.

4. The cutting and stapling device of claim 2 further comprising:

a second row of staples disposed within the cartridge, said cartridge being operable from the handle to eject the second row of staples from the cartridge into body tissue, said second row of staples being arranged generally parallel to the long axis of the device, radially offset from the long axis of the device opposite the first row of staples;

a third heating element comprising an electrically resistive wire disposed over the first grasping face, parallel to the long axis of the device, radially offset from the long axis of the device opposite the second heating element, wherein the electric current source is operably connected to the third heating element; and

a third controller operable to control current to the third heating element to heat the second heating element to temperatures sufficient to seal body tissue.

5. The cutting and stapling device of claim 4 wherein: the second heating element is disposed between the first heating element and the first row of staples; and the third heating element is disposed between the first heating element and the second row of staples.

6. A method of cutting and sealing tissue comprising the steps of:

providing a device for cutting and sealing tissue comprising:

an insertion rod;

a first jaw and a second jaw extending from the insertion rod, said first and second jaws being rotatably mounted to the insertion rod to allow closure of the first and second jaws, said first jaw having a first grasping face and said second jaw having a second grasping face, said first grasping face and said second grasping face aligned to meet each other upon closure of the first and second jaws;

a cartridge disposed inside the second jaw, said cartridge comprising:

a heating element support disposed in the cartridge;

a first heating element disposed on the heating element support along a longitudinal axis;

a second heating element disposed on the heating element support, said second heating element laterally spaced from, and parallel to, the first heating element;

a third heating element disposed on the heating element support, and further disposed opposite the second heating element;

11

a first row of staples disposed within the cartridge,
said first row of staples laterally spaced from, and
parallel to, the first heating element;
a second row of staples disposed within the
cartridge, and further disposed opposite the first
row of staples;
grasping tissue between the first and second grasping
faces;
adjusting the temperature of the second heating element
and the third heating element to a temperature of up to
about 99° Celsius until the tissue is sealed by cauter-
ization;
stapling the tissue together; and
adjusting the temperature of the first heating element to a
temperature above about 100° Celsius until the tissue is
severed.

12

7. The method of claim 6 wherein the steps of adjusting
the temperature of the first, second, and third heating ele-
ments is performed simultaneously with the step of stapling
the tissue together.
8. The method of claim 6 wherein the tissue comprises a
body lumen.
9. The method of claim 8 wherein the body lumen is a
section of colon.
10. The method of claim 6 wherein the tissue comprises
a diseased body organ.
11. The method of claim 6 wherein the tissue comprises
an injured body organ.

* * * * *

专利名称(译)	联合解剖，烧灼和缝合设备		
公开(公告)号	US6602252	公开(公告)日	2003-08-05
申请号	US10/037625	申请日	2002-01-03
[标]申请(专利权)人(译)	MOLLENAUER KENNETH ^ h		
申请(专利权)人(译)	MOLLENAUER KENNETH H.		
当前申请(专利权)人(译)	STARION仪器公司		
[标]发明人	MOLLENAUER KENNETH H		
发明人	MOLLENAUER, KENNETH H.		
IPC分类号	A61B17/12 A61B17/128 A61B18/04 A61B18/08 A61B17/068 A61B17/072 A61B17/32 A61B17/115 A61B17/11 A61B17/03 A61B17/00 A61B18/14 A61B18/18		
CPC分类号	A61B17/07207 A61B18/085 A61B17/1285 A61B17/068 A61B17/1114 A61B17/1152 A61B17/12 A61B2018/0063 A61B2017/00084 A61B2017/320052 A61B2018/00601		
其他公开文献	US20030125734A1		
外部链接	Espacenet USPTO		

摘要(译)

一种医疗装置，用于利用加热元件同时切割组织，用加热元件烧灼组织，并将组织缝合在一起。

