



(19) **United States**

(12) **Patent Application Publication**
Felsinger et al.

(10) **Pub. No.: US 2019/0085162 A1**

(43) **Pub. Date: Mar. 21, 2019**

(54) **SYNTHETIC TISSUE STRUCTURES FOR ELECTROSURGICAL TRAINING AND SIMULATION**

(71) Applicant: **Applied Medical Resources Corporation**, Rancho Santa Margarita, CA (US)

(72) Inventors: **Natasha Felsinger**, Rancho Santa Margarita, CA (US); **Sam Chehayeb**, Lake Forest, CA (US); **Eduardo Bolanos**, Rancho Santa Margarita, CA (US)

(21) Appl. No.: **16/138,652**

(22) Filed: **Sep. 21, 2018**

Related U.S. Application Data

(63) Continuation of application No. 15/208,873, filed on Jul. 13, 2016, now Pat. No. 10,081,727, which is a continuation of application No. PCT/US2016/032292, filed on May 13, 2016.

(60) Provisional application No. 62/161,322, filed on May 14, 2015, provisional application No. 62/257,877, filed on Nov. 20, 2015.

Publication Classification

(51) **Int. Cl.**
C08L 33/26 (2006.01)
C08J 5/12 (2006.01)
B29C 39/00 (2006.01)
G09B 23/30 (2006.01)
B29K 33/00 (2006.01)
A61B 18/12 (2006.01)

(52) **U.S. Cl.**
CPC *C08L 33/26* (2013.01); *C08J 5/122* (2013.01); *B29C 39/003* (2013.01); *G09B 23/30* (2013.01); *C08J 2333/26* (2013.01); *B29K 2033/26* (2013.01); *C08J 2405/04* (2013.01); *A61B 18/12* (2013.01); *B29K 2005/00* (2013.01)

(57) **ABSTRACT**

A surgical simulator for electrosurgical training and simulation is provided. The surgical simulator includes one or more simulated tissue structures made substantially of a hydrogel comprising a dual interpenetrating network of ionically cross-linked alginate and covalently cross-linked acrylamide. Combinations of different simulated tissue structures define procedural-based models for the practice of various electrosurgical procedures including laparoscopic total mesorectal excision, transanal total mesorectal excision, cholecystectomy and transanal minimally invasive surgery. Methods of making the simulated tissue structures are also provided.

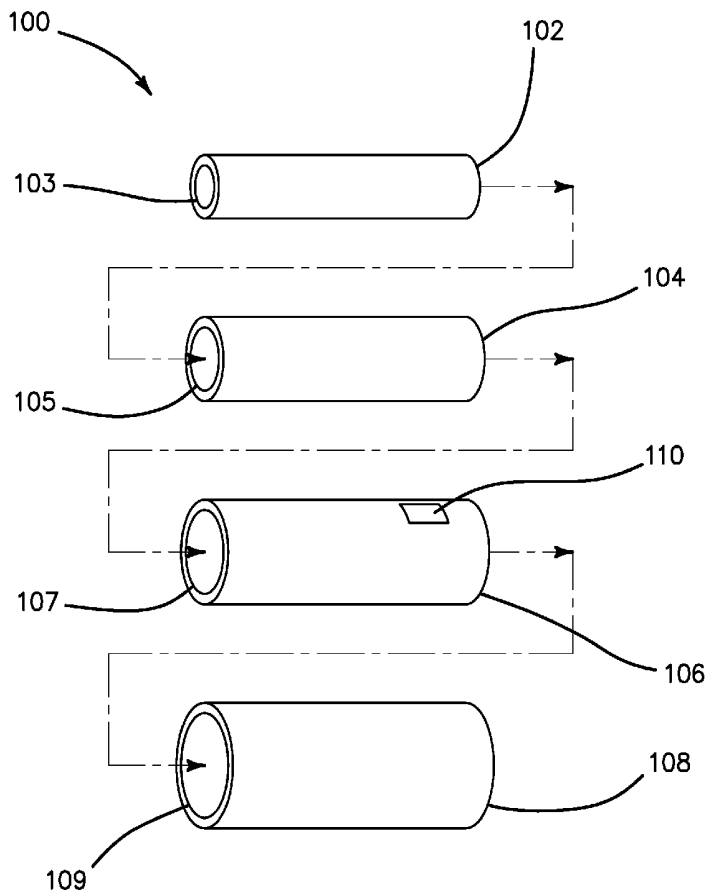

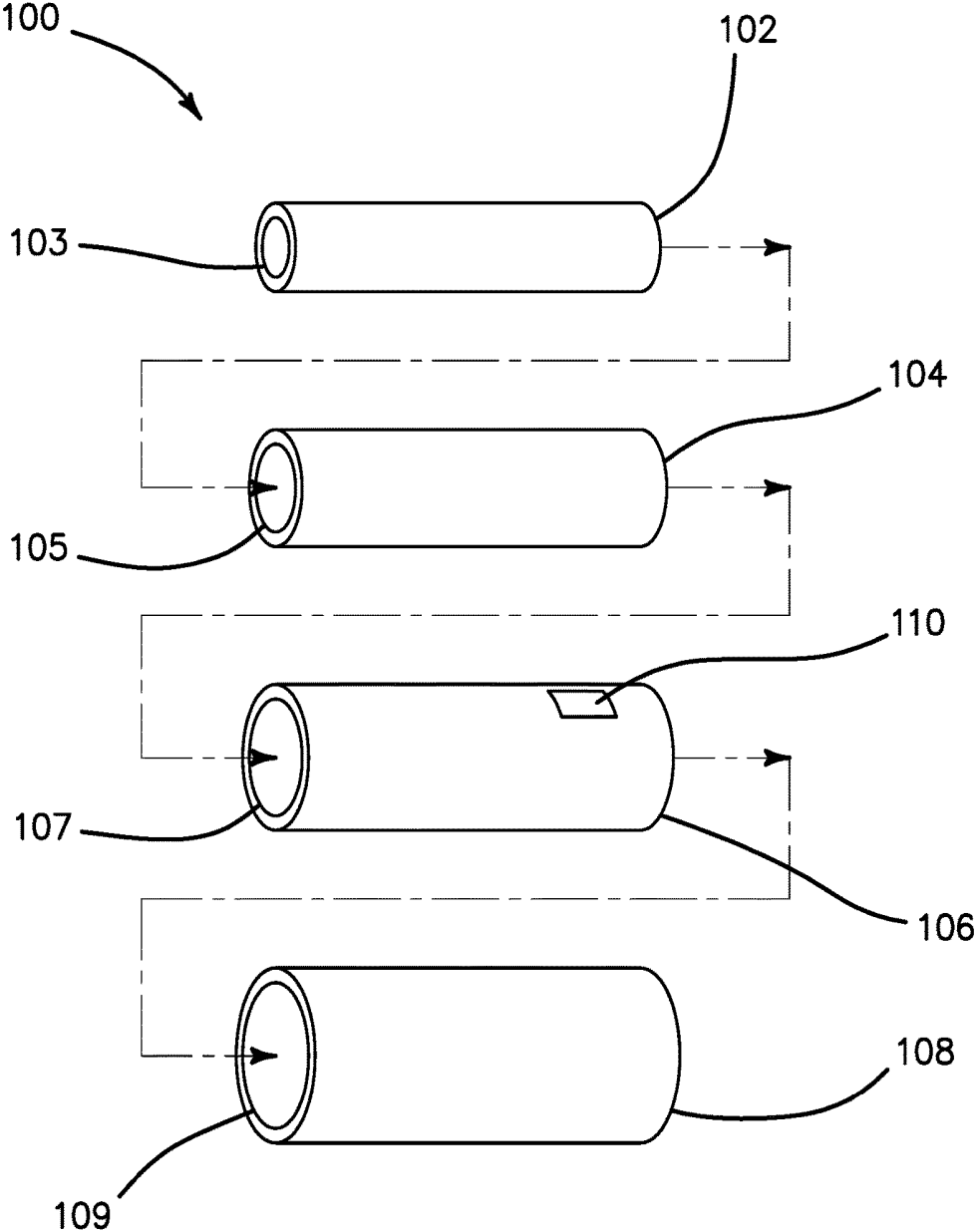

FIG. 1

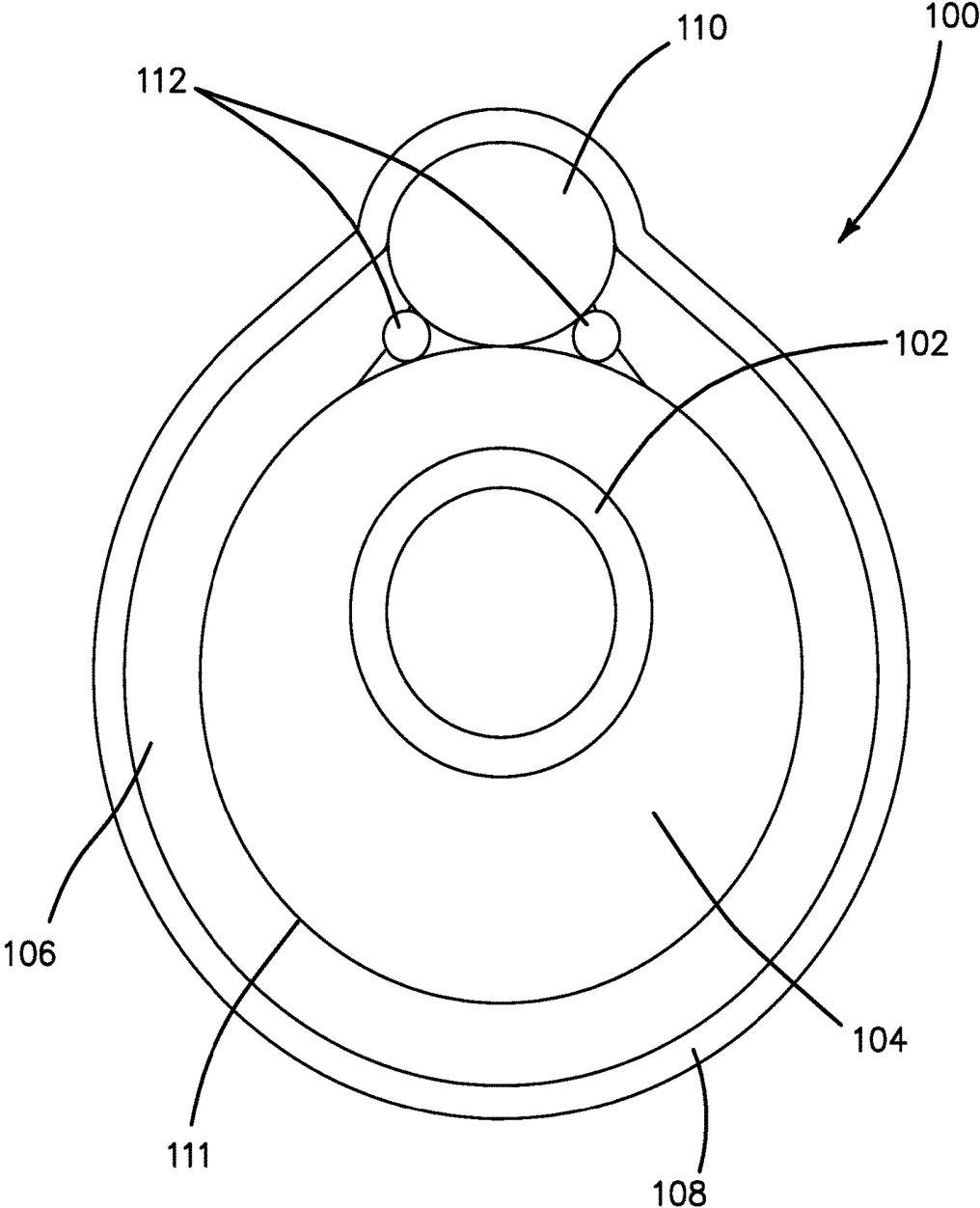
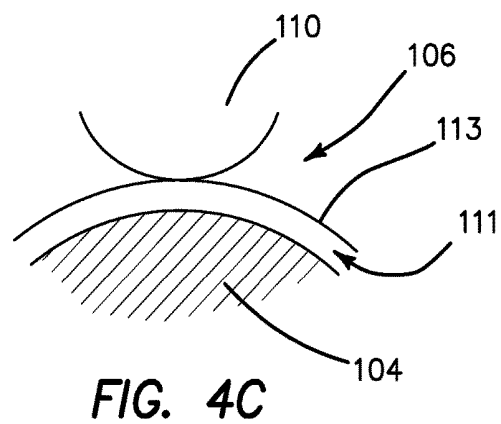
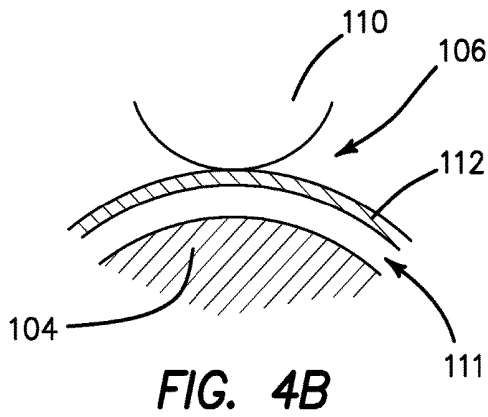
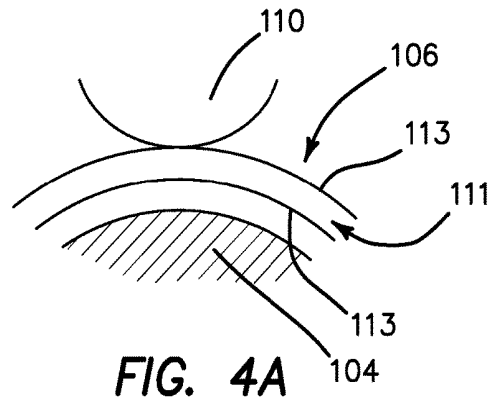
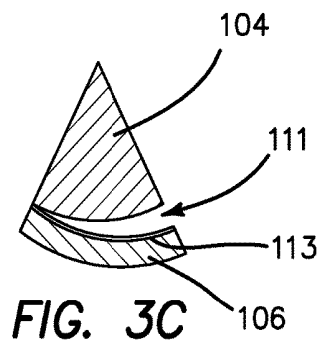
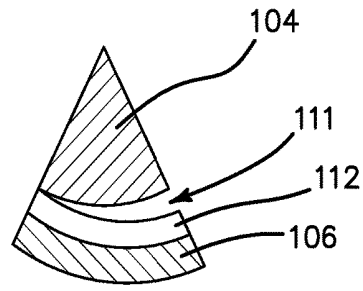
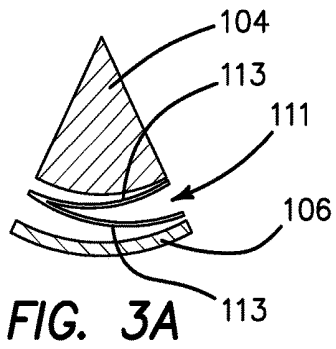

FIG. 2



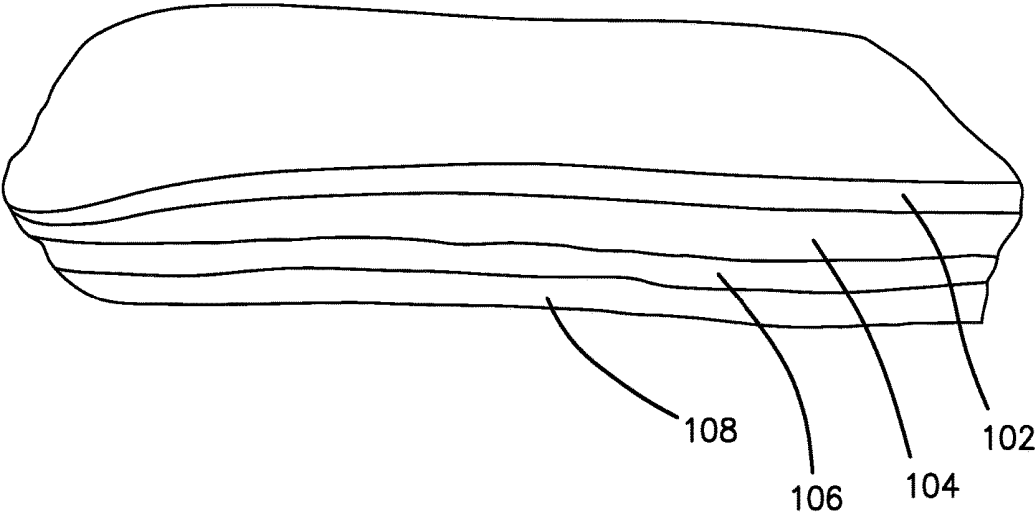

FIG. 5

SYNTHETIC TISSUE STRUCTURES FOR ELECTROSURGICAL TRAINING AND SIMULATION

CROSS-REFERENCE TO RELATED APPLICATIONS

[0001] This application is a continuation of U.S. patent application Ser. No. 15/208,873 entitled “Synthetic tissue structures for electrosurgical training and simulation,” filed on Jul. 13, 2016, which is a continuation of International Patent Application No. PCT/US2016/032292 filed on May 13, 2016 entitled “Synthetic tissue structures for electrosurgical training and simulation” which claims priority to and benefit of U.S. Provisional Patent Application No. 62/161,322 filed on May 14, 2015 entitled “Synthetic tissue for electrosurgical training and simulation”, and U.S. Provisional Patent Application No. 62/257,877 filed on Nov. 20, 2015 entitled “Synthetic tissue training for electrosurgical training and simulation” all of which are incorporated herein by reference in their entireties.

FIELD OF THE INVENTION

[0002] This application relates to synthetic tissue for practicing electrosurgical procedures and, in particular, to conductive synthetic tissue material made from a cross-linked hydrogel and methods of manufacturing such material and synthetic tissue models.

BACKGROUND OF THE INVENTION

[0003] Advances in technology have led to an increased use of energy devices in surgical procedures. There is a need for synthetic tissue that closely resembles the response of human tissue to electrosurgery. The synthetic tissue would be advantageous to surgeons and residents for training purposes. The synthetic tissue requires several characteristics to closely resemble human tissue including the ability to be cauterized, cut, and fused when manipulated with energy devices. Additionally, the tissue needs to emulate the mechanical properties of real tissue such as elasticity, toughness, suturability, tactility, color and texture. Furthermore, the material needs to be moldable into a structure that mimics various human organs or membranes for simulating human anatomy. The synthetic tissue may also need to be bondable to a variety of thermoplastics and silicones. The present invention addresses these needs.

SUMMARY OF THE INVENTION

[0004] According to one aspect of the invention, a surgical simulator for surgical training is provided. The surgical simulator includes a synthetic tissue structure formed at least in part of a hydrogel including an ionically cross-linked alginate network cross-linked with a covalently cross-linked acrylamide network. The synthetic tissue structure includes at least one of an artificial liver or artificial gallbladder. The at least one of the artificial liver or artificial gallbladder includes at least one lumen substantially formed of a hydrogel including an ionically cross-linked alginate network cross-linked with a covalently cross-linked acrylamide network.

[0005] According to another aspect of the invention, a surgical simulator for surgical training is provided. The surgical simulator includes a synthetic tissue structure substantially formed of a hydrogel including an ionically cross-

linked alginate network cross-linked with a covalently cross-linked acrylamide network. The synthetic tissue structure includes a first layer formed of the hydrogel having a first ratio of acrylamide to alginate by weight and a second layer formed of the hydrogel having a second ratio of acrylamide to alginate by weight. The second layer is adjacent to the first layer.

[0006] According to another aspect of the invention, a surgical simulator for surgical training is provided. The surgical simulator includes a simulated organ model. The simulated organ model includes a first tube having an outer surface and an inner surface defining a first lumen. The first tube is made of a hydrogel comprising a dual interpenetrated network of ionically cross-linked alginate and covalently cross-linked acrylamide having a first ratio of acrylamide to alginate. The simulated organ model includes a second tube having an outer surface and an inner surface defining a second lumen. The second tube is made of a hydrogel comprising a dual interpenetrated network of ionically cross-linked alginate and covalently cross-linked acrylamide having a second ratio of acrylamide to alginate. The first tube is coaxially located inside the second lumen such that the outer surface of the first tube is in contact with the inner surface of the second tube.

[0007] According to another aspect of the invention, a method of making a surgical simulator for the practice of electrosurgical techniques is provided. The method includes the steps of providing an acrylamide polymer, providing alginate polymer, providing water, mixing the water with the acrylamide and alginate to form a solution, adding ammonium persulfate to the solution, adding N,N-methylenebisacrylamide to the solution, adding calcium sulfate after the steps of adding ammonium persulfate and adding N,N-methylenebisacrylamide to the solution, casting the solution into a shape representative of an anatomical structure, and curing the solution to form a simulated electrosurgery model made of hydrogel for practicing and simulating electrosurgery.

[0008] According to another aspect of the invention, a method of making a surgical simulator for the practice of electrosurgical techniques is provided. The method includes the step of providing an uncured hydrogel including an ionically cross-linked alginate network cross-linked with a covalently cross-linked acrylamide network. The method includes the step of providing a polymer bag, pouring the uncured hydrogel into the polymer bag, sealing the polymer bag, curing the uncured hydrogel inside the polymer bag to form a cured hydrogel, and removing the cured hydrogel. The resulting structure is substantially planar sheet of hydrogel that can be used in building a larger procedural-based surgical training model.

BRIEF DESCRIPTION OF THE DRAWINGS

[0009] FIG. 1 is an exploded, top perspective view of an organ model according to the present invention.

[0010] FIG. 2 is a side, cross-sectional view of a rectum model with a simulated prostate system according to the present invention.

[0011] FIG. 3A is posterior, partial, cross-sectional view of two collagen layers located between a second tube and a third tube of a rectum model with according to the present invention.

[0012] FIG. 3B is a posterior, partial, cross-sectional view of a second tube, third tube and a thin hydrogel layer of a rectum model according to the present invention.

[0013] FIG. 3C is a posterior, partial, cross-sectional view of a second tube, third tube and a collagen layer of a rectum model according to the present invention.

[0014] FIG. 4A is an anterior, partial, cross-sectional view of two collagen layers located between a second tube and simulated prostate system of a rectum model according to the present invention.

[0015] FIG. 4B is an anterior, partial, cross-sectional view of a thin hydrogel layer located between a second tube and simulated prostate system of a rectum model according to the present invention.

[0016] FIG. 4C is an anterior, partial, cross-sectional view of a collagen layer between a second tube and a simulated prostate system of a rectum model according to the present invention.

[0017] FIG. 5 is a top perspective view of a multi-layered hydrogel according to the present invention.

DETAILED DESCRIPTION OF THE INVENTION

[0018] The material of the present invention is made from a dual interpenetrated cross-linked hydrogel network. The hydrogel is a mixture of two cross-linked polymers: an ionically cross-linked alginate network and a covalently cross-linked polyacrylamide network. The gel material is prepared by mixing an 8:3 ratio of acrylamide to alginate and water. In order to make the organ or tissue parts that are more realistic, color can be incorporated into the process. The colorant is added prior to deionized water being mixed with the acrylamide and alginate solids. Half the water being used to form the gel is used to make the colorant. A wash is created with the water and drops of acrylic paints. The amount and color of paint used varies depending on the organ. See Table 1 below for organ color ratios that show how many parts of each color need to be mixed together for a particular organ and/or tissue part. The colored wash is then combined back with the other half of water and mixed with the acrylamide and alginate. Water content of the gel is approximately 86 weight percent. Ammonium persulfate (0.003 the weight of the acrylamide) and N,N-methylenebisacrylamide (0.006 the weight of acrylamide) are added to the solution as a photo initiator and a cross-linker respectively, for the acrylamide. Further, the solution is flushed with argon gas and N,N,N',N'-tetramethylethylenediamine (0.003 the weight of acrylamide) is added under an argon atmosphere as a cross-linking accelerator for the acrylamide. The final additive, calcium sulfate (0.136 weight of alginate), is an ionic cross-linker for the alginate. The slurry is constantly stirred throughout each step until the solution is homogeneous. The gel solution is cast into organ shaped molds and placed in an 85° C. oven for 30 minutes to cure. See the Example below for a specific hydrogel procedure example. To obtain hollow organs, the gel solution can be painted onto a mandrel and placed under a heat lamp to cure. The cured product is a tough, clear hydrogel or colored replica of the organ or tissue. The application of hydrogel organs makes the organ trays for surgical training more dynamic, the trays become more life-like as well as energy device compatible.

[0019] In another variation, the material of the present invention is made from a dual interpenetrated cross-linked

hydrogel network. The hydrogel is a mixture of two cross-linked polymers: an ionically cross-linked alginate network and a covalently cross-linked polyacrylamide network. The gel material is prepared by mixing an 8:3 ratio of acrylamide to alginate and water. In order to make organs or tissue parts that are more realistic, color can be incorporated into the process. A colorant solution is prepared separate from the acrylamide and alginate mixture to allow for accessibility of different pigments while molding various tissue or organs. The colorant solution is prepared by dissolving acrylic paints in deionized water. The amount and color of paint used varies depending on the organ. See Table I for organ color ratios that show how many parts of each color need to be mixed together for a particular organ and/or tissue part. From the total amount of water used to create the hydrogel, half the water comes from the colorant solution. The colored solution is then combined back with the other half of water which is mixed with the acrylamide and alginate. The total water content of the gel is approximately 86 wt %. Ammonium persulfate (approximately 0.3% the weight of the acrylamide) and N,N-methylenebisacrylamide (approximately 0.6% the weight of acrylamide) are added to the solution as a photoinitiator and a cross-linker respectively, for the acrylamide. Further, the solution is flushed with argon gas for approximately 10-15 minutes in order to displace the air with an inert gas, and then N,N,N',N'-tetramethylethylenediamine (approximately 0.3% the weight of acrylamide) is added under an argon atmosphere as a cross-linking accelerator for the acrylamide. The final additive, calcium sulfate (approximately 13.6% weight of alginate), is an ionic cross-linker for the alginate. The slurry is constantly stirred throughout each step until the solution is homogeneous. The gel solution is cast into organ shaped molds and placed in an 85° C. oven for 60 minutes to cure. See Example below for a specific hydrogel procedure example. To obtain hollow organs, the gel solution can be painted onto a mandrel and placed under a heat lamp to cure. The cured product is a tough, clear hydrogel or colored replica of the organ or tissue. The application of hydrogel organs makes the organ trays for surgical training more dynamic, the trays become more life-like as well as energy device compatible.

[0020] Organs and/or tissue made of the hydrogel of the present invention closely resemble and react to manipulation with energy devices similar to the way human organs do. The synthetic tissue made of the hydrogel of the present invention can be cut, cauterized and fused. Two layers of the hydrogel tissue according to the present invention can be separated along a plane using various monopolar and bipolar devices. Furthermore, vessels of the hydrogel can be fused and transected like real blood vessels. Mechanical devices such as scissors, graspers, and sutures can also be used on synthetic tissue made from the hydrogel of the present invention. The tissue has the strength to accommodate sutures and can be further reinforced with mesh to allow additional strength to accommodate sutures in a manner used for actual surgeries without concern for the suture tearing through the synthetic tissue and coming undone. In addition, when wetted the material becomes lubricious and slick making for a life-like feel. The compatibility of the hydrogel with other materials becomes useful when making large assemblies, such as organ trays comprising multiple tissue components for simulators because the synthetic organs not only need to bond to each other, but also are able

to bond to the plastic base of the tray. The synthetic organs and tissues made of the hydrogel material should be stored in closed containers with minimal exposure to the atmosphere until ready for use. Due to being predominantly water, the hydrogel material can dry out over time if not stored properly. However, advantageously, the hydrogel of the present invention has the ability to reabsorb water allowing for it to rehydrate after losing moisture and to be used.

[0021] In another variation of the present invention, synthetic tissue is made as follows. Sodium metabisulfite is added as an additive to the above mentioned hydrogel. The sodium metabisulfite is added to the solution prior to the calcium sulfate. The amount utilized is equivalent to the amount of ammonium persulfate present in the gel solution. The addition of the sodium metabisulfite allows the gel to be cured at room temperature. Once cast, the hydrogel begins to instantly cure, thus the need for a secondary oven cure is no longer necessary. This process shortens the time required for producing the gel. However, the resulting tissue lacks the same tear strength, elongation, and work time as its oven-cured counterpart.

[0022] Another approach utilizes adjusting the ratios of ingredients already present in the hydrogel solution. The two polymers of the hybrid hydrogel are what allow the gel to be elastic and still hold its shape. The 8:3 polymer ratio of acrylamide to alginate in the gel can be adjusted to enhance different properties of the gel. The amount of acrylamide can be increased to increase flexibility and elasticity of the gel; inversely, if the amount of alginate is increased, brittleness is amplified and tear resistance is decreased. The cross-linkers are further responsible for certain characteristics. The cross-linkers essentially entangle the polymer strands together forming a polymer network. Increasing the amount of cross-linkers causes the hydrogel to cure faster and lack elasticity and an insufficient amount of cross-linkers causes the formation of a jelly rather than a gel. The amount of water can also be varied, with the amount of water being inversely proportional to hardness. Gel with higher water content will be softer and will have the formation of a jelly. Ultimately, the ingredients of the hybrid hydrogel can be utilized to enhance different physical and mechanical properties.

[0023] Two other examples of replacement hydrogels are an acrylic acid based gel and a clay-based gel. In the acrylic acid hydrogel, an acrylate polymer is created through the polymerization of acrylic acid in an aqueous solution neutralized by sodium hydroxide. A sodium metabisulfite-ammonium persulfate redox reaction acts as an initiator for the polymerization process. The clay based hydrogel is a solution of sodium polyacrylate and clay nanosheets. A dendritic molecular binder (G3-binder) is added to the solution to initiate bonding. The resulting product is a clear, moldable hydrogel.

[0024] Besides hydrogel materials semiconductive silicones can be utilized to produce synthetic organs. Semiconductive silicones are silicone rubbers that have been doped with small particles of metal, commonly, nickel-graphite or aluminum. These metal particles essentially make a non-conductive silicone semiconductive by providing a medium for electricity to flow through. Semiconductive silicones are expensive and difficult to bond to other materials. In addition, the silicone needs to contain large amounts of metal particles to provide a short enough arcing distance for the

electric current. The above materials and processes can similarly be engaged to manufacture organ trays that are energy compatible.

[0025] An exemplary organ model made of hydrogel material compositions described in this specification is shown in FIGS. 1-3. The organ model is a simulated rectum model **100**. The simulated rectum model **100** includes a first tube **102** made of any one of the hydrogel compositions described herein and dyed to have a pink color. In one variation, the hydrogel is selected to have a ratio of approximately 8:1 acrylamide to alginate and approximately 86% water. The first tube **102** defines a first lumen **103** extending between a proximal end and a distal end.

[0026] The simulated rectum model **100** further includes a second tube **104** defining a second lumen **105** and extending between a proximal end and a distal end. The second tube **104** is made of yellow dyed hydrogel of any one of the hydrogel compositions described herein. In one variation, the hydrogel is selected to have a ratio of approximately 8:1 acrylamide to alginate and approximately 86% water. The second lumen **105** is dimensioned to receive the first tube **102** inside the second lumen **105** in a concentric-like fashion. The second tube **104** is adhered to the first tube **102** using cyanoacrylate glue. Alternatively, the second tube **104** is cured onto the first tube **102** and no glue is employed. The yellow color of the second tube **104** is selected such that the second tube **104** represents the mesorectum of a human colon.

[0027] The model **100** further includes a third tube **106**. The third tube **106** defines a third lumen **107**. The diameter of the third lumen **107** is dimensioned to receive the second tube **104** inside the third lumen **107** in a concentric fashion. The third tube **106** is adhered to the second tube **104** by being cured on top of the second tube **104**. The third tube **106** is made of any one of the hydrogel compositions described herein and dyed to have a yellow and/or orange color to represent a presacral fat layer. In one variation, the hydrogel is selected to have a ratio of approximately 8:1 acrylamide to alginate and approximately 86% water.

[0028] The simulated rectum model **100** further includes a fourth tube **108**. The fourth tube **108** defines a fourth lumen **109**. The diameter of the fourth lumen **109** is dimensioned to receive the third tube **106** inside the fourth lumen **109** in a concentric-like fashion. The fourth tube **108** is made of any one of the hydrogel compositions described herein and dyed to have a pink color. In one variation, the hydrogel is selected to have a ratio of approximately 8:1 acrylamide to alginate and 86% water. The fourth tube **108** is adhered to the third tube **106** with adhesive such as cyanoacrylate glue such as LOCTITE® 401 or 4902 cyanoacrylate glue manufactured by LOCTITE® of Westlake, Ohio. Alternatively, the fourth tube **108** is cured onto the third tube **106** and no adhesive is employed.

[0029] In one variation of the simulated rectum model **100**, the simulated rectum model **100** further includes a simulated prostate system **110** located and embedded between the third tube **106** and the fourth tube **108**. In one variation, the simulated prostate system **110** is located and embedded inside the third tube **106**. The simulated prostate system **110** is located at the anterior side of the model **100**. The simulated prostate system **110** includes any one or more of the following simulated anatomical structures: simulated prostate, simulated seminal vesicles, simulated bladder, simulated urethra, and simulated vas deferens. The simu-

lated urethra and simulated vas deferens are made of silicone formed into a solid tube or other polymer. The simulated seminal vesicles are made of urethane or other foam overmolded onto the simulated vas deferens. The simulated prostate is made of urethane or other foam overmolded onto the simulated urethra.

[0030] In one variation of the simulated rectum model **100**, the simulated rectum model **100** further includes one or more collagen layer (not shown) located in any one or more of the following locations: (1) between the second tube **104** and the first tube **102**, (2) between the third tube **106** and the second tube **104**. The collagen layer is wetted and placed onto the cured hydrogel tube which is then placed in an oven to adhere it. In one variation, the second tube **104** is covered with a thin layer of collagen and the third tube **106** is covered with a thin layer of collagen and electro-surgical dissection takes place between the two adjacent layers of collagen. In another variation, a thin collagen layer is applied to the third tube **106** only and dissection is between the second tube **104** and the collagen layer on the third tube **106**. In another variation, a thin first collagen layer is applied to the second tube **104**, a thin second collagen layer is applied to the first collagen layer. The prostate system **110** is adhered to the second collagen layer and care is taken to dissect around the prostate system between the first collagen layer and the second collagen layer. In another variation, a thin collagen layer is applied to the prostate system **110** and care is taken to dissect between the second tube **104** and the thin collagen layer to avoid the prostate system **110**.

[0031] The simulated rectum model **100** is fantastically suited for practicing transanal total mesorectal excision (TaTME) for cancer located in the lower rectum using electro-surgical devices and electro-surgery techniques. In such a surgical procedure, the cancerous rectum is approached through the anus into the first lumen **103** via a sealable port that is connected to channel. A purse-string suture is tied to seal off the cancerous location of the rectum that includes the tumor. In order to practice this suture technique, the first tube **102** is optionally provided with an embedded mesh layer so that sutures would be held in the first tube **102** and not tear through the hydrogel when pulled. In another variation, the purse-string suture is pre-made during the manufacturing process so that the surgeon can visually locate the suture and only practice techniques subsequent to purse-string suture placement. In the practice of the procedure, the surgeon will commence to dissect in the posterior direction and electro-surgically cut down through first tube **102** and into the second tube **104** which represents the mesorectum and circumferentially around the second tube **104** between the second tube **104** and the third tube **106** being careful not to penetrate into the simulated prostate system **110** and not to penetrate into the fourth tube **108** as can be seen in FIG. 2. Care is also taken not to enter the simulated mesorectum (second tube **104**) nor enter into the first tube **102**. The user carefully practices to dissect circumferentially around the first tube **102**. Exemplary posterior dissection locations and dissection pathways are illustrated in FIGS. 3A-3C. FIG. 3A illustrates a posterior dissection location between the second tube **104** and the third tube **106** and a dissection plane **111** in between two collagen layers **113** if they are employed. FIG. 3B illustrates a posterior dissection location with a dissection pathway between the second tube **104** and the third tube **106**, and in particular, between the second tube **104** and a thin hydrogel

layer **112** located between the third tube **106** and the second tube **104**. FIG. 3C illustrates a posterior dissection location with a dissection pathway **111** between the second tube **104** and a collagen layer **113** adhered to the third tube **106**. After dissecting posteriorly, anterior dissection begins by dissecting through the thinner layer of the second tube **104**, visible in FIG. 2, until the third tube **106** is reached. Dissection proceeds between the second tube **104** and the third tube **106** along a dissection plane **111** until the posterior dissection is encountered. Exemplary anterior dissection locations and dissection pathways **111** that correspond to posterior dissection pathways **111** of the models configured as shown in FIGS. 3A, 3B and 3C are illustrated in FIGS. 4A, 4B and 4C, respectively. FIG. 4A illustrates an anterior dissection location with a dissection plane **111** lying between two collagen layers **113** if they are provided. FIG. 4B illustrates an anterior dissection location with a dissection plane **111** lying between the second tube **104** and the thin layer of hydrogel **112**. FIG. 4C illustrates an anterior dissection location with a dissection plane **111** lying between the second tube **104** and collagen layer **113** if one is provided. Care is taken not to enter the third tube **106** to avoid risk damaging the prostate system **110**.

[0032] The proximal end of the simulated rectum model **100** may be attached to a transanal adapter. The transanal adapter is a support used to space apart the top cover from the base of a surgical trainer to provide access into the model from the side of the surgical trainer. An example of a surgical trainer is described in U.S. Pat. No. 8,764,452 incorporated by reference herein in its entirety. The transanal adapter includes an opening that is connected to the first lumen of the first tube **102**. Surrounding the opening of the transanal adapter, soft silicone is provided to simulate an anus. The practice of the surgical TaTME procedure is performed through the opening of the transanal adapter into the first lumen **103** as described above.

[0033] In one variation, the first tube **102** and the second tube **104** are made of hydrogel having a ratio of approximately 8:1 acrylamide to alginate and approximately 86% water and the third tube **106** and the fourth tube **108** are made of hydrogel having a ratio of approximately 8:3 acrylamide to alginate and approximately 86% water. Whereas the intersection of layers/tubes having the same ratio are substantially indistinguishable, the intersection of layers/tubes having different ratios are distinguishable making the intersection plane discernible and more easily separable, leading the practitioner along the correct dissection plane and making dissection easier than if the correct dissection plane was the intersection of layers/tubes having the same ratio.

[0034] The simulated rectum model **100** is assembled by first casting the material into hollow tube-like molds that are provided with mandrels. The casting of layers may begin from the innermost layer and proceed to the outermost layer or vice versa. For example, if the casting is to start from the innermost layer, a small tube is filled with material and allowed to cure in an oven. When removed from the small tube mandrel, the cured innermost layer is inserted into a larger diameter tubular mandrel of the desired diameter and the next layer is poured and allowed to cure. The combination is then removed and placed into a tubular mandrel having a larger diameter and the next layer is poured and so forth. Similarly, the model **100** may be constructed beginning with the outer layer and sequentially proceeding to the

inner layer. Tubing is placed inside of a larger hollow tubing and the outermost space in between is filled with material until the desired layers is achieved working progressively until the innermost layer is poured. Any layer can be offset from the longitudinal axis to achieve a thicker or thinner layer posteriorly or anteriorly as needed such as for the second tube. If a purse-string suture is to be pre-made, the outer-to-inner manufacturing process would be employed. On the last innermost layer, instead of placing a mandrel in all of the way, material would be cast to completely fill in the rectum except for the top portion. On the top, a small mandrel would be placed allowing only the very top to be hollow. The mandrel could be designed to look like a purse-string, giving the user a visual cue that the purse-string suture has been already completed. To apply a collagen layer, synthetic or natural collagen casing is employed in the form of a sheet or cylinder. If provided in the form of a cylinder, it is cut into sheets. The collagen layer is then soaked in water and water is brushed onto the desired layer of application. The soaked collagen layer is then placed onto the layer of hydrogel. More layers are added as needed and the hydrogel layer and collagen layer are baked together in an oven to adhere the hydrogel to the collagen or the collagen to itself when multiple layers are employed side-by-side. The model **100** is held together by over molding the layers or with cyanoacrylate glue. Silicone components of the model **100** such as the prostate system **110** are adhered to the hydrogel or collagen using cyanoacrylate glue. Urethane molds are employed and the molds may be surface treated with in a variety of ways including but not limited to plasma treating and flame treating to make the mold hydrophilic and improve spreading of hydrogel material into the mold, especially for a hydrogel formulation that does not include sodium metabisulfide. Certain model organ parts, especially thin sheet-like parts such as a simulated peritoneum, are formed by polybag casting. In polybag casting, the hydrogel material is poured into a bag. Any air pockets are pressed out and the bag is sealed and placed between two flat trays. Weights of approximately 2.5-5.0 pounds were laid on top of the trays and allowed to cure into a flat sheet to create an artificial peritoneum or omentum. Artificial vasculature also made of hydrogel may be embedded by arranging the artificial vasculature inside the polybag. Also, smaller hollow molds are utilized to manufacture simulated hollow vessels.

[0035] In another variation, the model **100** does not have a cylindrical shape to represent a rectum. Instead, the model **100** simply includes four layers **102**, **104**, **106**, **108** from top to bottom in the shape of a rectangular or square block as if the cylinder were to be cut open and laid flat as shown in FIG. 5. The block configuration of the layers permits the user to practice the procedures without being confined to a lumen configuration with the procedures performed trans-luminally. The block allows practitioners to simply practice the electrosurgical techniques in a laparoscopic environment such with the model **100** placed inside a cavity of a surgical trainer between a top cover and a base. In such a variation, the first layer **102** and the second layer **104** are made of hydrogel having a ratio of approximately 8:1 acrylamide to alginate and approximately 86% water and the third layer **106** and the fourth layer **108** are made of hydrogel having a ratio of approximately 8:3 acrylamide to alginate and approximately 86% water.

[0036] Any one of the hydrogels disclosed in this specification can be used to form at least part of a simulated tissue structure for the practice of surgical techniques, especially laparoscopic electro-surgical procedures wherein the simulated tissue structure is disposed inside an enclosure substantially enclosing the simulated tissue structure. An example of an enclosure includes a laparoscopic trainer in which a laparoscope is utilized to visualize the surgical field. The simulated tissue structure is not limited to artificial vessels, arteries, veins, one or more organs and tissues, hollow or solid, associated with the human lower rectum as described above and suitable for practicing a TaTME procedure. Also, the TaTME model described above may be made with two layers of hydrogel instead of four layers. In such a model the two layers made of hydrogel include the rectum layer and mesorectum layer, the first tube **102** and the second tube **104**, respectively, if the model is formed to have a tubular shape. A variation of such a TaTME model having two layers includes a mesh layer located between the two layers **102**, **104**. Of course, the TaTME model need not have a tubular shape. Any of the TaTME models may include artificial polyps to be practiced for removal using energy. A gallbladder model may include one or more of an artificial liver, artificial gallbladder, artificial peritoneum, artificial fascia, artificial duct(s), and one or more artificial artery. In an alternative variation of the gallbladder model, the artificial liver is excluded from being made of hydrogel and instead made of silicone or KRATON in order to localize the surge areas to the locations where a simulated procedure would be performed. A simulated tissue structure is substantially made of any one of the hydrogels described herein. In one variation, the simulated tissue structure includes an artificial human ovarian organ that includes one or more of a simulated ovary portion, a uterine horn portion, uterus, ovary, fallopian tube, vagina, cervix, bladder, omentum, and peritoneum. The peritoneum and omentum may further include embedded simulated vasculature, hollow or solid, also made of hydrogel. Other artificial organs that are made of hydrogel and form at least part of a simulated tissue structure include an artificial stomach, kidney, rectum, aorta, tumor, and polyp. Any of the simulated tissue structures made of hydrogel described herein may include a mesh layer. Also, the simulated tissue structure may include two different hydrogels forming different parts of the simulated tissue. For example, as described above, part of a simulated tissue structure may be made with a hydrogel having an 8:3 formulation and another part having an 8:1 formulation. Also, part of a simulated tissue structure may be formed of a hydrogel according to the present invention and part made of silicone or other material and attached, connected, adjacent or in juxtaposition to the part made of hydrogel. For example, in a simulated appendectomy model, an artificial colon is made of silicone and an artificial peritoneum and vessels are made of hydrogel having one or more formulation described herein. In another example, in a simulated gallbladder model the artificial liver is made of silicone or KRATON and all other parts of the gallbladder model are made of hydrogel having one or more formulation described herein. In another example, an artificial rectum is made of silicone and artificial polyps of hydrogel described herein are adhered to the silicone rectum using cyanoacrylate glue.

[0037] In use, the simulated tissue structure according to the present invention is configured for use with electrosurgical units, including but not limited to monopolar, bipolar,

harmonic or other devices employed in electrosurgery, in order to provide a realistic medium configured into an anatomical portion for the practice of using electrosurgical units, electrosurgical techniques, surgical procedures employing electrosurgical units alone and with other instruments encountered in surgery. The handling of electrosurgical units requires practice as does employing surgical techniques and learning specific procedures performed with the electrosurgical units. When an electrosurgical unit is applied, heat is generated by the electrical current traveling between two polarities in a bipolar system or from one electrical polarity to a ground in a monopolar system. Typically, in a monopolar system, the artificial tissue structure is located above and in contact with a grounding plate/pad which is connected to a ground. In one variation of the simulated tissue structure according to the present invention, that portion of the structure that is composed of hydrogel is placed in direct contact with the grounding pad/plate or other conductive surface. In the event, the entirety of the simulated tissue structure is configured such that the hydrogel is not in direct contact with the grounding pad, a conductive pathway, such as a wire or the like, is provided to contact the hydrogel portion and then pass across non-conductive portions of the model to contact the grounding pad. For example, in a gallbladder model such as the model described in U.S. Patent Application Publication No. US 2014/0370477 to Applied Medical Resources Corporation in California, the anatomical portion is connected to a support in order to permit the model to stand upright. If any one of the liver, peritoneum, gallbladder, vasculature, fascia, duct system or other component of the model is made of hydrogel, a wire is passed into that portion and then fed to contact a metallic frame which is set inside the stand with the frame legs extending all the way through the stand to be exposed at the bottom surface of the stand which then can be placed atop a grounding pad. When the hydrogel structure is contacted with an electrosurgical unit, the temperature of the hydrogel structure will increase to a temperature that begins to vaporize the water content of the hydrogel in the location of contact. Because the hydrogel contains approximately 86% water by weight of the hydrogel structure, the model will generate steam that mimics the smoke created during electrosurgery performed on human tissue. Advantageously, the water vapor of the hydrogel structure is not odiferous compared with the smoke produced by real tissue. With prolonged contact with the electrosurgical unit, the water content will be reduced in the location of contact advantageously creating a simulated fusion or seal of tissue typically encountered in real surgery. Hence, the present invention not only advantageously simulates the look and feel of tissue structures that would undergo procedures that employ electrosurgery, but also, responds in manner that mimics real electrosurgery when electrosurgery is applied to the simulated tissue structures. The hydrogel of the present invention can be utilized to simulate dissection of tissue in addition to sealing and/or fusion via an electrosurgical unit.

TABLE 1

ORGAN	COLOR RATIO
Liver	4 red:1 black
Gallbladder	3 yellow:1 blue
Cystic duct	3 yellow:1 blue
Kidney	4 red:1 blue

TABLE 1-continued

ORGAN	COLOR RATIO
Spleen	4 red:1 blue
Pancreas	4 yellow
Omentum	4 yellow:1 white
Mesentery	4 yellow:1 white (serial diluted 8 times)
Veins	3 blue:0.5 black
Arteries	5 red:0.25 black
Aorta	4 red

EXAMPLE

[0038] The following is an example procedure for making a simulated hydrogel liver according to the present invention. In a large glass beaker, add 33.75 g alginate and 90 g acrylamide. Dry mix the two solids until the mixture is uniform. Measure out 614 ml of deionized (DI) water. Add 307 ml (about half) of the 614 ml of DI water to the beaker with the powder mixture. Mix the solution to break apart any alginate adhered to the sides or bottom of the beaker. Once a homogenous solution is formed, maintain the mixing by placing the beaker under an overhead mixer or insert a stir bar and place on stir plate to continue mixing. The remaining 307 ml of water are added to a different beaker and used to prepare the colorant. For a simulated liver, 4 drops of red acrylic paint and 1 drop of black acrylic paint are added to the second jar of DI water and stirred on a stir plate until the water is a uniform color. The now colored 307 ml of DI water is combined back with the other half in the beaker of gel solution. The beaker of gel solution remains mixing on the overhead mixer or stir plate to dissolve all solids and allow for uniform mixing of the colorant. Keep solution stirring and add 0.250 g of ammonium persulfate (APS) and add 0.050 g N,N'-methylenebisacrylamide. Allow the APS and N,N'-MBAA to dissolve in the gel solution prior to proceeding. Hand mix as necessary, since the solution is viscous and the lighter additives will not readily mix with the mixers.

[0039] While on the overhead mixer or stir plate, insert a thin hose into the bottom of the beaker of gel solution, the hose should be connected to the argon gas tank. Bubble in a stream of argon gas into the beaker for approximately 15 minutes. Afterwards, remove the hose from the solution and allow hose to sit above the surface and blow a stream of argon gas on top of the gel solution for another 5 minutes. After flushing the solution with argon gas remove the thin hose from the jar. The following step is also completed under argon conditions. Flush the headspace of the N,N,N',N'-tetramethylethylenediamine (N,N,N',N'-TMEDA) bottle with argon. Using a micropipette, pipette 0.290 milliliters of argon gas from the N,N,N',N'-TMEDA bottle head space and eject the gas off to the side, this should be done twice in order to flush the interior of the micropipette. Now, extract 0.290 ml of N,N,N',N'-TMEDA from the bottle using the same micropipette tip and eject into the gel solution. The N,N,N',N'-TMEDA bottle should be sealed quickly after use and stored in a dark area, away from moisture.

[0040] Continue stirring, make a slurry of calcium sulfate dihydrate (CaSO₄·2H₂O) and DI water. Add approximately 25 ml of DI water to 4.59 g of CaSO₄·2H₂O. Mix thoroughly and add slurry to the hydrogel solution. Wash the remains of the CaSO₄·2H₂O slurry with DI water and add

to the hydrogel solution. Some white clouds may still remain from the addition of the $\text{CaSO}_4 \cdot 2\text{H}_2\text{O}$. These clouds will disappear once hydrogel is cured. Allow gel slurry to mix at medium speed for approximately 1 minute. The gel slurry can now be poured into a liver mold and placed in an oven at 85°C . for 60 minutes to cure the gel. After 1 hour, the mold is removed from the oven and allowed to cool to room temperature. Once cool, the hydrogel liver can be removed from the mold. The final product is a life-like synthetic liver capable of being manipulated with energy devices in addition to mechanical devices.

[0041] It is understood that various modifications may be made to the embodiments of the synthetic tissue disclosed herein. Therefore, the above description should not be construed as limiting, but merely as exemplifications of preferred embodiments. Those skilled in the art will envision other modifications within the spirit and scope of the present disclosure.

1. A method of making a surgical simulator, comprising: providing a solution comprising an acrylamide polymer, an alginate polymer and water; casting the solution into hollow tube molds; curing the solution in the hollow tube molds to form hollow tubes made of hydrogel; and arranging the formed hollow tubes of hydrogel to form a simulated electrosurgery model for practicing and simulating electrosurgery.
2. The method of claim 1 wherein at least one of the hollow tube molds includes a mandrel.
3. The method of claim 1 further comprising providing a colorant and mixing the colorant into the provided solution.
4. The method of claim 1 further comprising flushing the provided solution with argon gas.
5. The method of claim 1 further comprising adding a persulfate to the provided solution.
6. The method of claim 1 wherein the arranging the formed hollow tubes of hydrogel further comprises concentrically placing the formed hollow tubes of hydrogel within each other.
7. The method of claim 6 further comprising providing a collagen layer and placing the collagen layer in between the concentrically placed hollow tubes of hydrogel.
8. The method of claim 1 wherein the arranging the formed hollow tubes of hydrogel further comprises stacking the formed hollow tubes of hydrogel on each other.
9. The method of claim 8 further comprising overmolding the stacked formed hollow tubes of hydrogel.

10. The method of claim 8 further comprising adhering the stacked formed hollow tubes of hydrogel together.

11. A method of making a surgical simulator, comprising: providing a first solution comprising an acrylamide polymer, an alginate polymer and water; casting the first solution into a first hollow tube mold; curing the first solution in the hollow tube molds to form a first hollow tube made of hydrogel; providing a second solution comprising an acrylamide polymer, an alginate polymer and water; placing the first hollow tube in a second hollow tube mold; pouring the second solution over the first hollow tube; curing the second solution and the first hollow tube to form a simulated electrosurgery model for practicing and simulating electrosurgery.

12. The method of claim 11 further comprising providing a colorant and mixing the colorant into at least one of the provided first solution and second solution.

13. The method of claim 11 further comprising flushing at least one of the provided first solution and second solution with argon gas.

14. The method of claim 11 further comprising adding a persulfate to at least one of the provided first solution and second solution.

15. A surgical simulator for surgical training comprising: a synthetic tissue model comprising:

a first tube formed of a hydrogel including an alginate network cross-linked with an acrylamide network; and

a second tube formed of a hydrogel including an alginate network cross-linked with an acrylamide network, the first tube having a first diameter larger than a second diameter of the second tube.

16. The surgical simulator of claim 15 wherein the second tube is disposed within the first tube.

17. The surgical simulator of claim 15 wherein the second tube is positioned on the first tube.

18. The surgical simulator of claim 15 further comprising a layer disposed over the first tube, the layer being made of at least one of silicone, mesh, urethane and hydrogel.

19. The surgical simulator of claim 15 further comprising a conductive pathway coupled to the first tube and extending away from the first and second tubes.

20. The surgical simulator of claim 15 wherein the hydrogel of the first and second tubes each has a ratio of acrylamide to alginate by weight, each ratio being the same.

* * * * *

专利名称(译)	用于电外科训练和模拟的合成组织结构		
公开(公告)号	US20190085162A1	公开(公告)日	2019-03-21
申请号	US16/138652	申请日	2018-09-21
[标]申请(专利权)人(译)	应用医疗资源		
申请(专利权)人(译)	应用医疗资源CORPORATION		
当前申请(专利权)人(译)	应用医疗资源CORPORATION		
[标]发明人	FELSINGER NATASHA CHEHAYEB SAM BOLANOS EDUARDO		
发明人	FELSINGER, NATASHA CHEHAYEB, SAM BOLANOS, EDUARDO		
IPC分类号	C08L33/26 C08J5/12 B29C39/00 G09B23/30 A61B18/12 B29K33/00		
CPC分类号	A61B18/12 B29K2005/00 B29K2033/26 C08J2405/04 C08L33/26 B29C39/003 G09B23/30 C08J5/122 C08J2333/26		
优先权	62/257877 2015-11-20 US 62/161322 2015-05-14 US		
外部链接	Espacenet USPTO		

摘要(译)

提供了一种用于电外科训练和模拟的手术模拟器。手术模拟器包括一个或多个基本上由水凝胶制成的模拟组织结构，该水凝胶包括离子交联的藻酸盐和共价交联的丙烯酰胺的双互穿网络。不同模拟组织结构的组合定义了用于各种电外科手术的实践的基于程序的模型，包括腹腔镜全直肠系膜切除术，经肛门全直肠系膜切除术，胆囊切除术和经肛门微创手术。还提供了制造模拟组织结构的方法。

