



US 20130231677A1

(19) **United States**

(12) **Patent Application Publication**  
**Carroux**

(10) **Pub. No.: US 2013/0231677 A1**

(43) **Pub. Date: Sep. 5, 2013**

(54) **URETERAL CALCULUS SUCTION INSTRUMENT HAVING A SHAFT**

(30) **Foreign Application Priority Data**

Jun. 18, 2010 (DE) ..... 10 2010 024 360.4

(75) Inventor: **Alexander Carroux**, Waltham, MA (US)

**Publication Classification**

(73) Assignee: **OLYMPUS WINTER & IBE GMBH**, Hamburg (DE)

(51) **Int. Cl.**  
*A61B 17/22* (2006.01)

(52) **U.S. Cl.**  
CPC ..... *A61B 17/22* (2013.01)  
USPC ..... **606/127**

(21) Appl. No.: **13/805,284**

(57) **ABSTRACT**

(22) PCT Filed: **May 18, 2011**

A ureteral calculus suction instrument having a shaft through which a suction channel that can be connected to a suction device passes, wherein a collecting container having a distal opening and a proximal opening is arranged distally from the shaft, of which openings the proximal opening is connected to the distal end of the suction channel

(86) PCT No.: **PCT/EP11/02465**

§ 371 (c)(1),  
(2), (4) Date: **May 20, 2013**

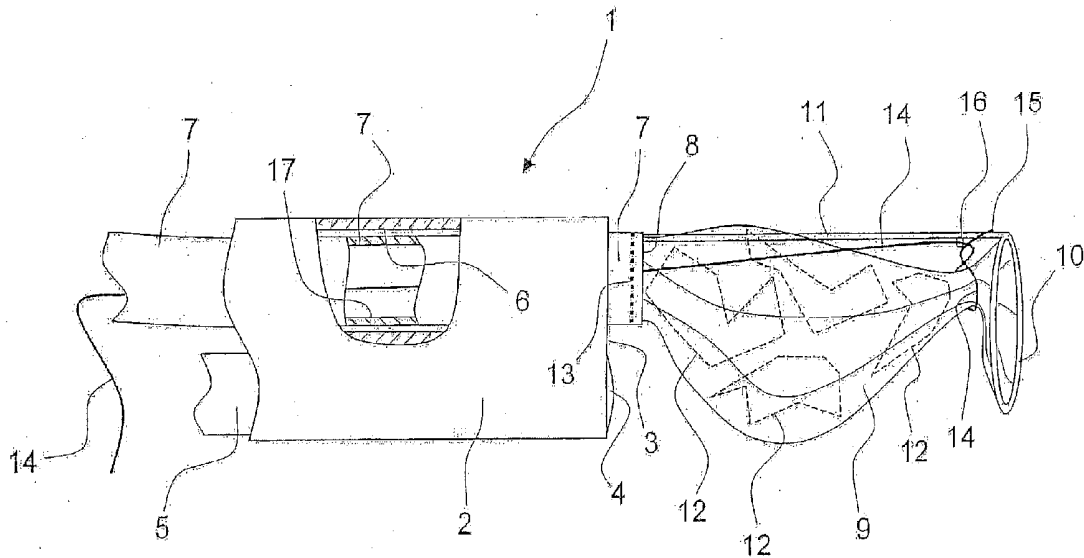

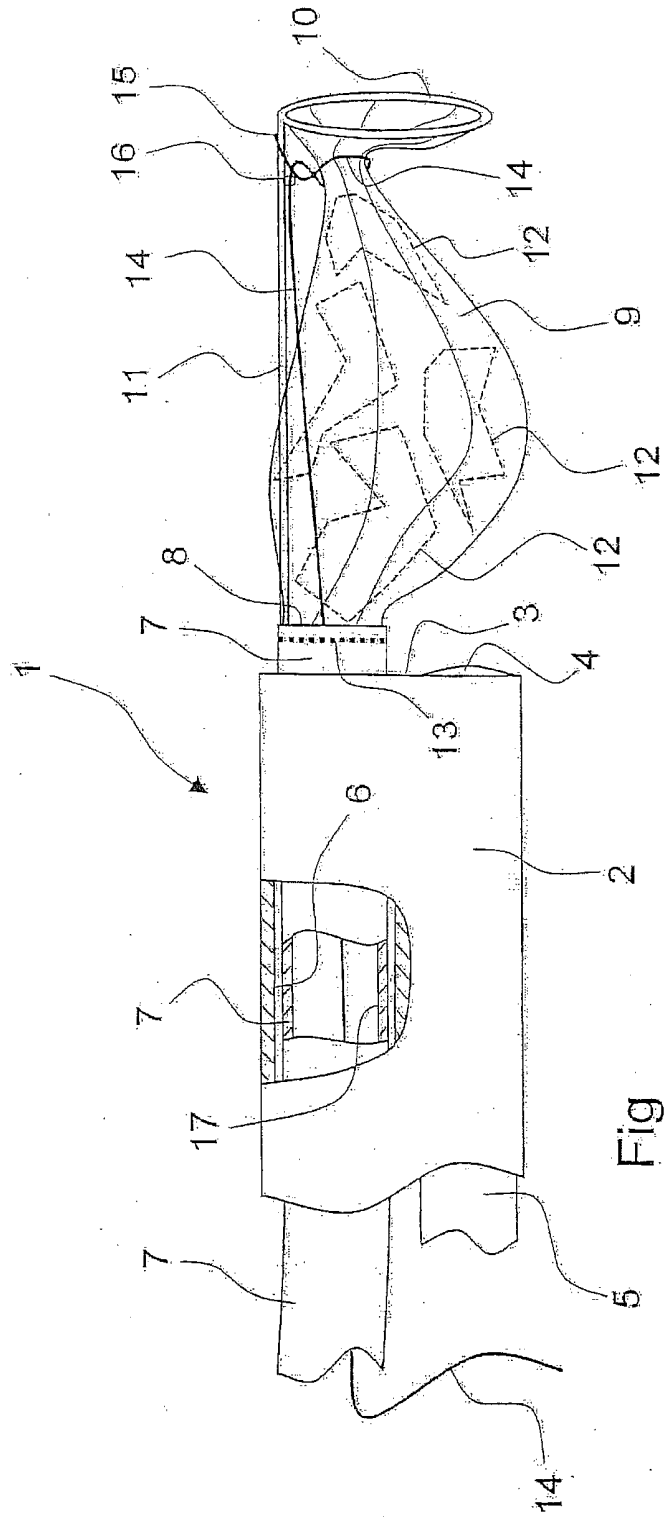

## URETERAL CALCULUS SUCTION INSTRUMENT HAVING A SHAFT

### CROSS-REFERENCE TO RELATED APPLICATION

[0001] The present application is based upon and claims the benefit of priority from PCT/EP2011/002465 filed on May 18, 2011, which claims benefit to DE 10 2010 024 360.4 filed on Jun. 18, 2010, the entire contents of each of which are incorporated herein by reference.

### BACKGROUND

[0002] 1. Field The present invention generally relates to a ureteral calculus suction instrument, and particularly to a ureteral calculus suction instrument of the type referred to in claim 1.

[0003] 2. Prior Art

[0004] Ureterscopes serve to work in the ureter, the channel within the body which connects the kidneys to the bladder. Because this channel is very narrow, the diameter of the shaft of the ureterscope must not be more than a maximum of 4-5 mm.

[0005] The very narrow cross-section of the shaft must accommodate the image conductor of an optical system. This exhibits at the distal end of the shaft a lens, from which an image conductor runs along the length of the shaft, consisting of rod lenses located one behind another, a light-conducting fibre bundle, or a video cable attached to a video camera.

[0006] With known ureterscopes, a channel is arranged in the remaining very narrow cross-section, which serves as a working channel to accommodate instruments such as, for example, a lithotripter, for example in the form of a laser fibre, but which can also be used as a suction channel. The ureterscope can therefore be used as a generic ureteral calculus suction instrument, in order to extract by suction calculus fragments produced with the lithotripter.

[0007] A disadvantage with the known generic ureteral calculus suction instruments is the suction of calculus fragments through the suction channel, which is very narrow, with a cross-section in the size range of the calculus fragments, as a result of which blockages occur due to calculus fragments becoming wedged in the suction channel. As well as this, the size of the calculus fragments which can be suctioned off is limited by the diameter of the suction channel.

### SUMMARY

[0008] An object of the present invention is to improve the generic ureteral calculus suction instrument in respect of the blockage problems and the restriction on the size of the calculi which can be suctioned off.

[0009] According to the invention, a collecting container with two openings is arranged distally before the ureteral calculus suction instrument, wherein the suction channel is connected to one of the openings. In consequence, the fluid in which this operation is conducted is suctioned through the distal opening and through the collecting container. Calculus fragments which are suctioned off pass into the collecting container and can be held in this and removed with this, without them having to be moved through the suction channel. The removal of the collecting container can take place together with the shaft of the ureteral calculus suction instrument, which may be a ureterscope, such that the full cross-section of the ureterscope is available for the expansion of

the collecting container. In this way, therefore, very large calculi or calculus fragments can be removed.

[0010] The suction channel can be formed by the working channel present in a conventional ureterscope. The collecting container can be arranged at its distal end, before the ureterscope, and with its proximal opening connected to the distal mouth of the working channel. Advantageously, however, the features of claim 2 are provided. In this situation, the suction channel is formed in a hose. This may serve directly as the shaft of the ureteral calculus suction instrument. The shaft may, however, also be used in the working channel of a ureterscope, from which it can be withdrawn, such that the full cross-section of the working channel is available for a lithotripter, such as a laser fibre.

[0011] The collecting container may be secured directly to the hose, and pushed with this into the working channel of the ureterscope. The features of claim 3 are advantageously provided for this purpose. With a flexible design of the collecting container, it can be pushed forwards, folded together, through the narrow working channel of the ureterscope, in order then to unfold distally before the ureterscope into the container shape. The flexibility should be carefully selected, in order to lend both the hose as well as the collecting container a certain inherent rigidity. Both require this in order not to collapse during suction.

[0012] If the collecting container is very soft, it may be difficult to hold its distal opening in a position which is favourable for the suction of calculus fragments. Accordingly, the features of claim 4 are provided. In this situation, the wall material of the collecting container can be very soft, but the distal opening is held with a support device, such that it remains open and stands in a suitable position. The support device may be, for example, a separate wire frame, to which the wall material of the collecting container is secured. The bracing can be integrated into the wall material of the collecting container. The wall material of the collecting container may also be of a suitable strength to form the support device, which advantageously, according to claim 5, is flexible. It is therefore possible for the support device to be formed with larger dimensions than the cross-section of the working channel. The support device can then be pushed through the working channel, like the collecting container, in a folded state, in order then to unfold in front of it.

[0013] Advantageously, according to claim 6, the distal opening of the collecting container can be closed. This prevents the calculi held in the collecting container from falling out again, which can happen with the high stresses imposed when the collecting container is drawn out together with the ureterscope.

[0014] In order to prevent calculi or calculus fragments which are suctioned into the collecting container from passing into the suction channel and then blocking it, it is possible, for example, for the mouth edge of the suction channel to be somewhat reduced in diameter, such that only very small calculus fragments can pass into the suction channel, with which the risk of blockage is reduced. Such measures, however, lead to a reduction in the suction capacity, which makes the suctioning of calculus fragments more difficult. The features of claim 7 are therefore advantageously provided. A filter in the region of the entry to the suction channel, which may be formed, for example, as a relatively coarse grille with low flow resistance, keeps calculi away, such that they remain in the collecting container. By way of this measure, the blockage of the suction channel is extremely effectively prevented.

[0015] Advantageously, according to claim 8, the collecting container and the shaft are formed individually or collectively, for preference as a structural unit, as a one-off disposable article, as a result of which excellent sterility is assured.

[0016] The ureteral calculus suction instrument may exhibit as the shaft only the hose, which can also be formed as a rigid tube, in order to allow for reliable steering and control when pushed forwards into the body. Advantageously, however, according to claim 9, the ureteral calculus suction instrument is formed as a ureteroscope. This provides a range of advantages, such as, for example, the optical system provided in the ureteroscope, which allows for suction extraction to take place under visual monitoring and control.

#### BRIEF DESCRIPTION OF THE DRAWING

[0017] In the drawing, the invention is represented by way of example and schematically in the FIGURE, which shows a side view of the distal end region of a ureteral calculus suction instrument according to the invention in the form of an ureteroscope.

#### DETAILED DESCRIPTION

[0018] Represented in the FIGURE is a ureteral calculus suction instrument in the form of a ureteroscope 1, with only the distal end region of its shaft 2 represented. The shaft 2 ends distally with its distal face surface 3, in which a lens 4 of an optical system is located, which exhibits an image conductor 5 running through the shaft 2, which conveys the image acquired by the lens 4 to the proximal end of the shaft 2, in order to be observed or displayed there. The image conductor 5 can be designed as an arrangement of rod lenses or as a light-conducting fibre bundle. A camera can also be arranged at the lens 4, wherein the image conductor 5 is designed as a video cable.

[0019] In a sectional region of the shaft 2 it can be seen that a working channel 6 runs through this. In a usual arrangement this is open at both ends. In the embodiment shown, it accommodates a hose 7 with a lumen 17, which can be connected at the proximal end, not shown, to a suction device, such as a pump.

[0020] The region represented of the ureteroscope 1, when in use in accordance with the intended purpose, is arranged in the ureter or in the renal pelvis respectively, i.e. in fluid. This can be suctioned off through the hose 7 with its lumen 17 serving as a suction channel.

[0021] With the hose 7 withdrawn, a lithotripter, not shown, can be introduced through the working channel 6, i.e. an instrument for disintegrating kidney calculi lying in the ureter or in the renal pelvis respectively. The calculus fragments remaining after the disintegration must then be removed.

[0022] The lithotripter used heretofore, which was relocated through the working channel 6, may for example be designed as a shock wire of a shockwave lithotripter, or as a light conducting fibre of a laser lithotripter. After the destruction of a blocking calculus has been completed, the lithotripter is withdrawn from the working channel 6, and the hose 7 can now be pushed into the working position as shown. If suction is now imposed through the hose 7, calculus fragments could become wedged in the interior of the hose and block it. The arrangement as represented is provided in order to avoid this.

[0023] At the distal edge 8 of the hose 7, a collecting container 9 is secured with the edge of a proximal opening. A

second distal opening of the collecting container 9 is secured to a ring 10, which, being carried by a rod 11, is held at a distance in front of the edge 8 of the hose 7.

[0024] With the embodiment shown, with the support device 10, 11 for holding the distal opening of the collecting container 9, the collecting container 9 can consist of very light, flexible material, as is represented in the FIGURE. It should still have a residual rigidity, however, in order not to collapse during suction and close off the flow.

[0025] The FIGURE shows that four calculus fragments 12, represented as broken line outlines, are lying in the interior of the container 9. They were aspirated through the distal opening of the container 9, defined by the ring 10. The calculus fragments 12 could, under strong suction, be suctioned into the hose 7, which is to be prevented in order not to incur blockages. For this purpose, a filter 13 is arranged close to the edge 8 in the hose 7, i.e. in the region of the transition between the hose 7 and the collecting container 9, which is formed, for example, as a grille and retains the calculus fragments 12.

[0026] Close to the distal end of the collecting container 9, i.e. adjacent to the ring 10, a loop of a thread 14 is looped around the container 9. The thread is secured to the rod 11 at 15, and, after looping around the collecting container 9, runs through a guide eye 16 on the rod 11, and from there through the hose 7 to the outside. The operator can draw on the outer end of the thread 14 in order to tighten the loop.

[0027] The collecting container 9 can thereby be closed at both ends, namely at one end by the filter 13, and at the other end by the loop of the thread 14. The collecting container 9 can now also be moved in a general manner without the calculus fragments 12 being able to escape from it.

[0028] The collecting container 9 and also the ring 10 of the support device are formed as elastically flexible, and can be laid or folded together sufficiently far as to be able to be pushed through the working channel 6 when introduced, before they can deploy into the position shown. Likewise, the collecting container 9 and the ring 10 can also be drawn in a backwards direction again, i.e. in the proximal direction, through the working channel 6. In this way, smaller calculi can be conveyed with the collecting container 9 through the working channel 6 to the outside. If larger calculus fragments or many calculus fragments are arranged in the collecting container 9, as is shown in the FIGURE, then the collecting container 9 is drawn out together with the entire ureteroscope 1, in order to remove the calculi.

[0029] The collecting container 9 can be formed in a manner other than that shown, e.g. widening in a funnel shape from the edge 8 to the ring 10, and made of relatively rigid self-supporting material, such that this material itself forms the support device. There is then no need for a separate rod 11 and a separate ring 10.

[0030] The collecting container 9 may also be secured directly at the distal end 8 of the working channel 6, such that there is no need for a separate hose 7.

[0031] Conversely, the shaft 2 of the ureteroscope 1 can also be done without, and the hose 7 itself can be used as a shaft.

[0032] The collecting container 9 can be formed as a closed film, or, for example, also from perforated material, provided that the perforations do not interfere too much with the desired proximal flow from the distal to the proximal opening of the collecting container 9, which could prevent the aspiration of calculi.

[0033] The hose 7 and the collecting container 9 are for preference formed as one-off disposable articles and are manufactured welded in sterile form.

[0034] While there has been shown and described what is considered to be preferred embodiments of the invention, it will, of course, be understood that various modifications and changes in form or detail could readily be made without departing from the spirit of the invention. It is therefore intended that the invention be not limited to the exact forms described and illustrated, but should be constructed to cover all modifications that may fall within the scope of the appended claims.

1. A ureteral calculus suction instrument comprising:  
a shaft, through which a suction channel runs, said suction channel being connectable to a suction device; and  
a collecting container with a distal and proximal opening arranged distally from the shaft, of which the proximal opening is connected to the distal end of the suction channel.
2. The ureteral calculus suction instrument according to claim 1, wherein the shaft is formed as a hose.
3. The ureteral calculus suction instrument according to claim 1, wherein the collecting container is formed so as to be flexible.

4. The ureteral calculus suction instrument according to claim 1, wherein the distal opening of the collecting container is held by means of a support device.

5. The ureteral calculus suction instrument according to claim 4, wherein the support device is designed so as to be flexible.

6. The ureteral calculus suction instrument according to claim 1, wherein the collecting container is arranged such as to be closable in the region of its distal opening.

7. The ureteral calculus suction instrument according to claim 1, further comprising a filter arranged in the region of the proximal opening of the collecting container so as to block the access to the suction channel.

8. The ureteral calculus suction instrument according to claim 1, wherein one or more of the collecting container and the shaft are formed as one-off disposable articles.

9. The ureteral calculus suction instrument according to claim 1, wherein the ureteral calculus suction instrument is formed as a ureteroscope and the suction channel is arranged in the working channel of the ureteroscope.

\* \* \* \* \*

|                |  |         |            |
|----------------|--|---------|------------|
| 专利名称(译)        | 具有轴的输尿管结石抽吸器械  |         |            |
| 公开(公告)号        | <a href="#">US20130231677A1</a>  | 公开(公告)日 | 2013-09-05 |
| 申请号            | US13/805284  | 申请日     | 2011-05-18 |
| [标]申请(专利权)人(译) | CARROUX ALEXANDER  |         |            |
| 申请(专利权)人(译)    | CARROUX , ALEXANDER  |         |            |
| 当前申请(专利权)人(译)  | OLYMPUS WINTER & IBE GMBH  |         |            |
| [标]发明人         | CARROUX ALEXANDER  |         |            |
| 发明人            | CARROUX, ALEXANDER   |         |            |
| IPC分类号         | A61B17/22  |         |            |
| CPC分类号         | A61B1/00087 A61B17/22 A61B1/307 A61B17/221 A61B17/3207 A61B19/5212 A61B2017/0023 A61B2017/00274 A61B2017/00287 A61B2017/22079 A61B2017/2215 A61B2018/00547 A61B2217/005 A61M1/008 A61B1/015 A61B90/361 |         |            |
| 优先权            | 102010024360 2010-06-18 DE   |         |            |
| 其他公开文献         | US9339283  |         |            |
| 外部链接           | <a href="#">Espacenet</a> <a href="#">USPTO</a>  |         |            |

摘要(译)

一种输尿管结石抽吸器械，具有轴，通过该轴可以连接到抽吸装置的抽吸通道，其中具有远端开口和近端开口的收集容器布置在远离轴的远侧，其中开口连接到近端开口到吸入通道的远端

