



(19) **United States**

(12) **Patent Application Publication**
Gan

(10) **Pub. No.: US 2013/0109924 A1**

(43) **Pub. Date: May 2, 2013**

(54) **SUCTION RETRACTOR**

(52) **U.S. Cl.**

(75) Inventor: **Philip Gan**, Warrnambool (AU)

CPC *A61B 17/02* (2013.01)

USPC **600/205**

(73) Assignee: **LIVAC PTY LTD**, Warrnambool (AU)

(57) **ABSTRACT**

(21) Appl. No.: **13/697,470**

(22) PCT Filed: **May 13, 2011**

(86) PCT No.: **PCT/AU2011/000567**

§ 371 (c)(1),
(2), (4) Date: **Dec. 12, 2012**

(30) **Foreign Application Priority Data**

May 13, 2010 (AU) 2010902064

Publication Classification

(51) **Int. Cl.**
A61B 17/02 (2006.01)

The subject invention provides a suction retractor comprising a flexible continuous dam which forms a closed loop of any shape and which defines one or more inlet opening into an interior of the closed loop, so that suction can be applied into an interior of the continuous dam. The suction retractor may further comprise a suction tube defining a suction channel, the suction tube attached to or attachable to the continuous dam and when attached the suction channel continuous with the one or more inlet. The one or more inlet may open to a continuous channel extending throughout an interior of the closed loop. Preferably, the continuous dam is planar or substantially planar and comprises a first compacted configuration for insertion and a second open configuration for retraction. The suction retractor of the invention finds application in single incision and convention laparoscopic surgery.

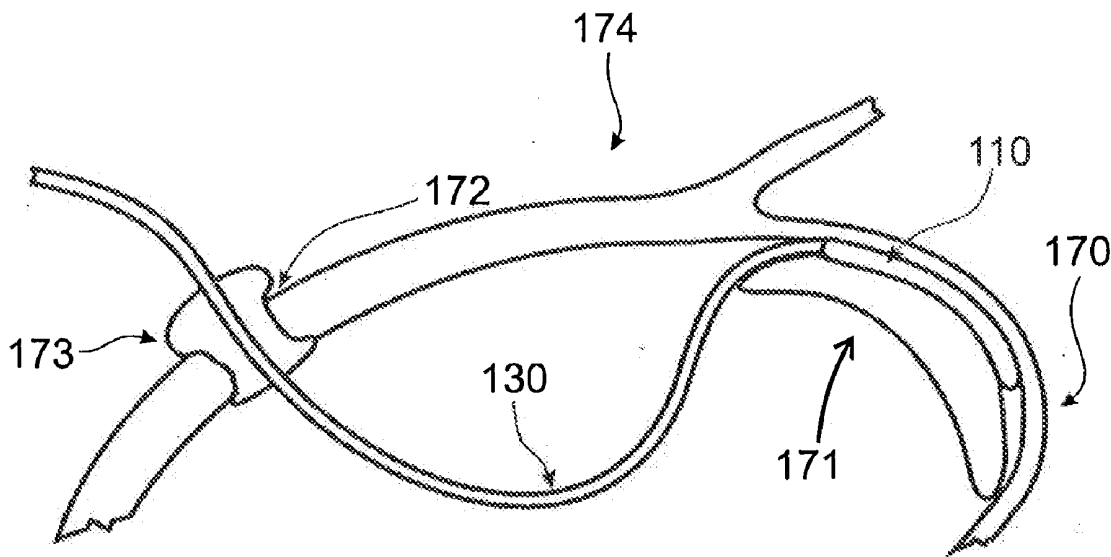

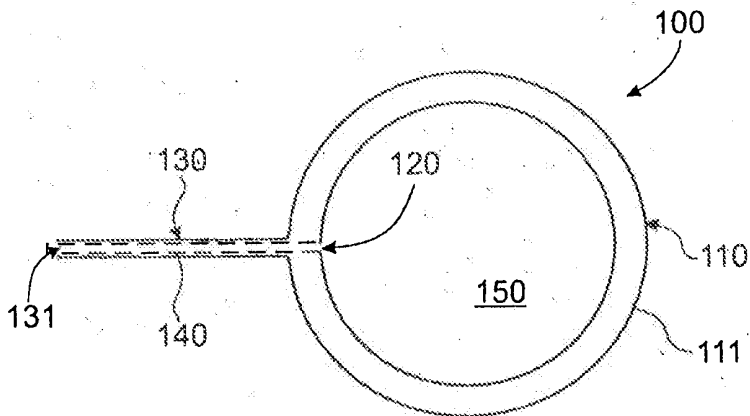

FIG. 1A (i)

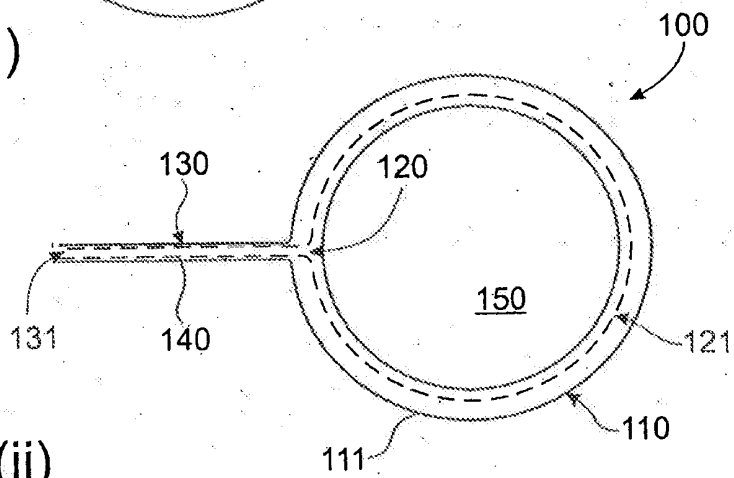

FIG. 1A (ii)

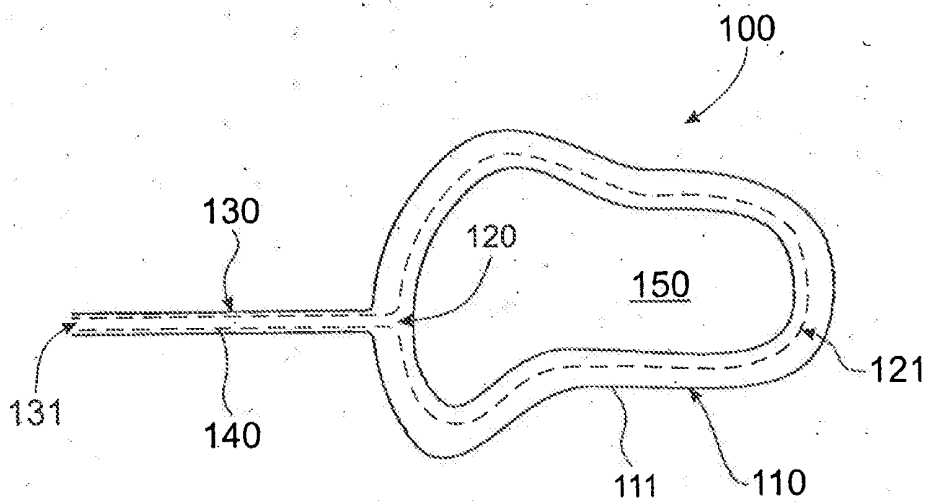

FIG. 1B

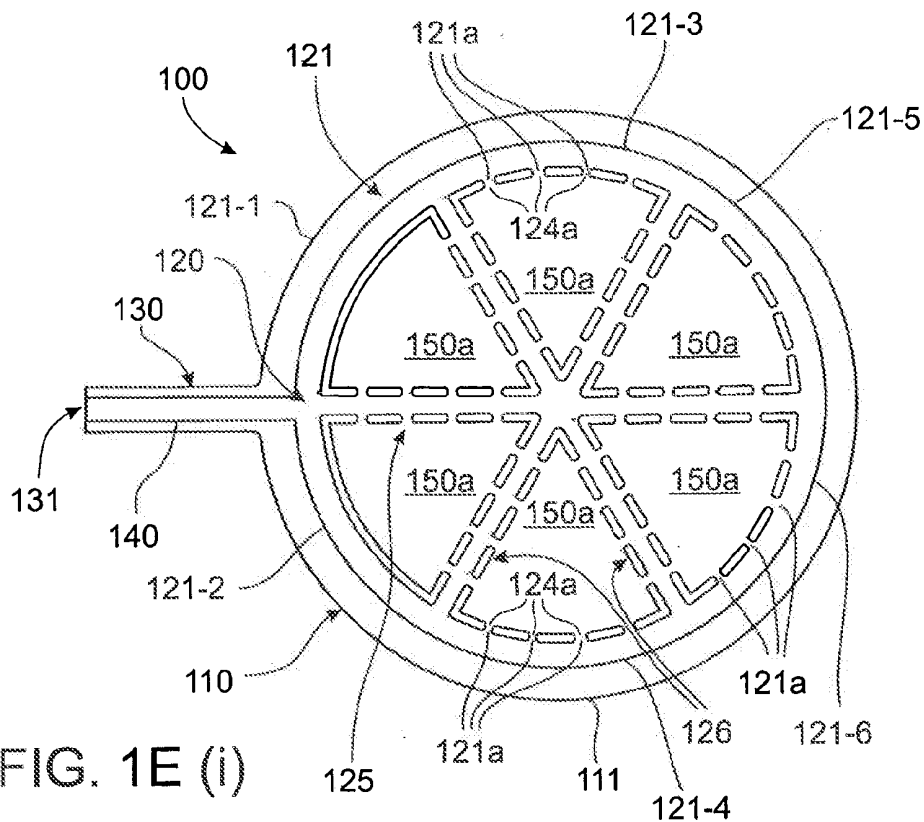

FIG. 1E (i)

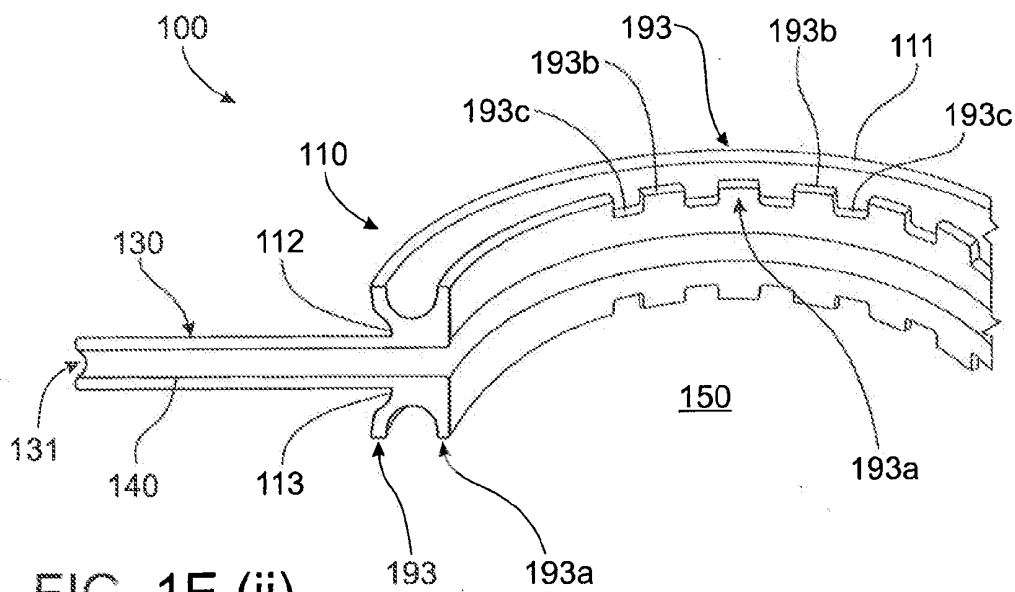

FIG. 1E (ii)

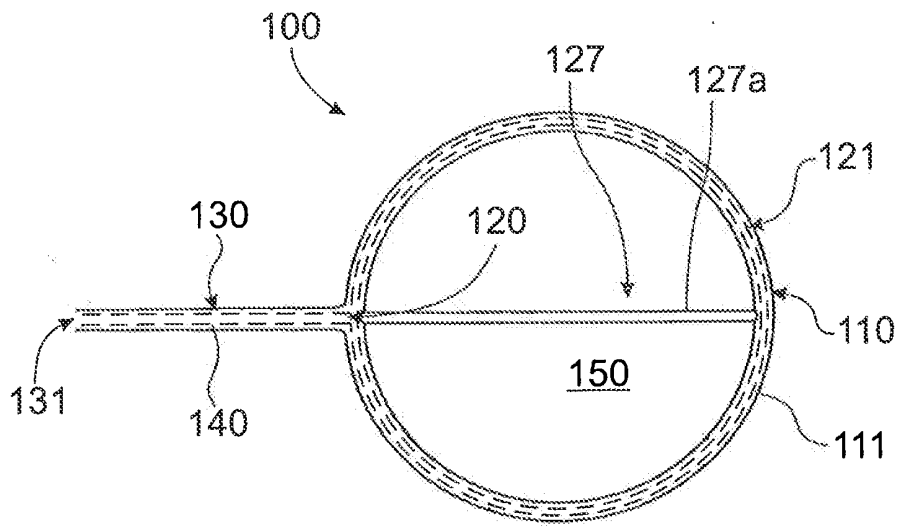

FIG. 1F(i)

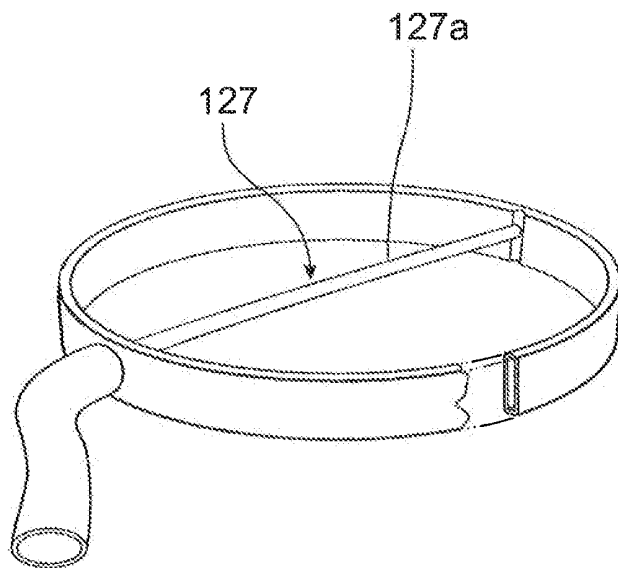

FIG. 1F(ii)

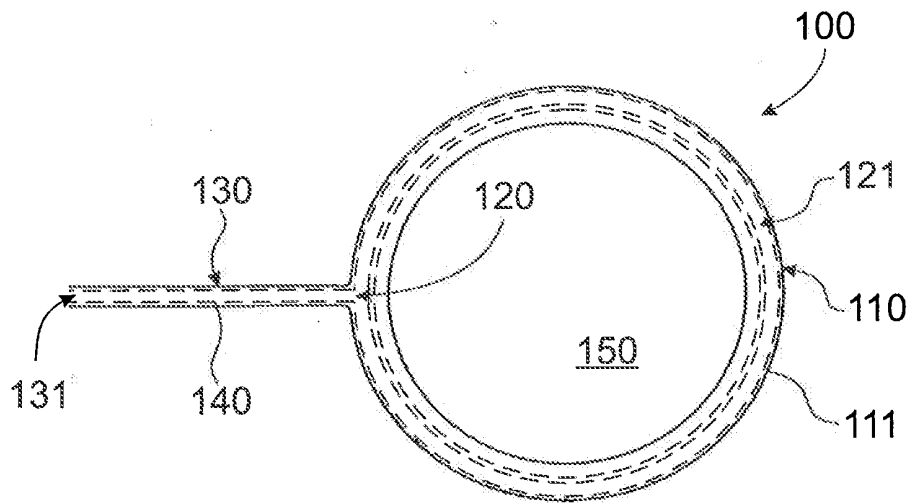

FIG. 1G (i)

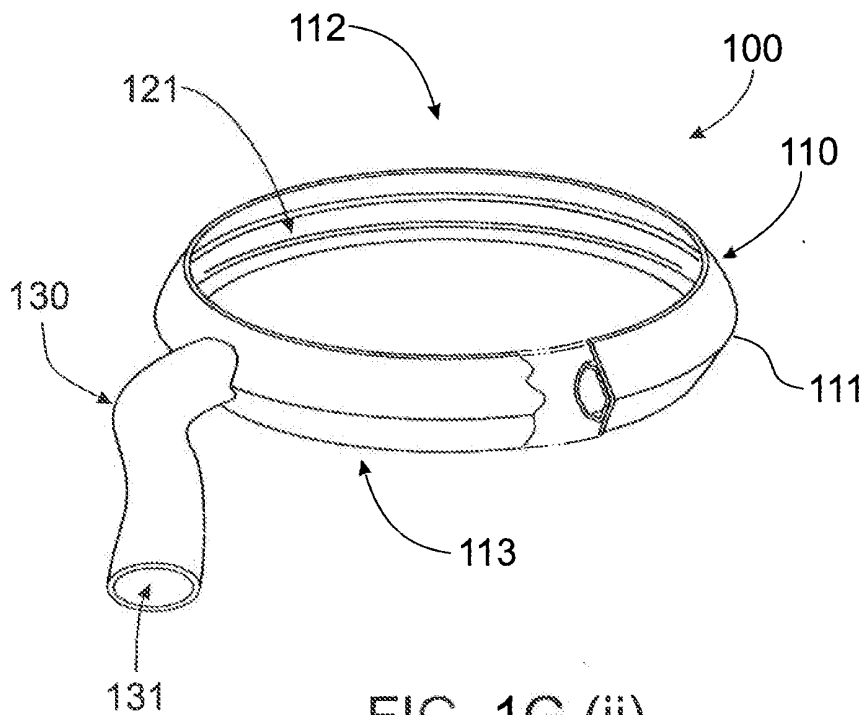

FIG. 1G (ii)

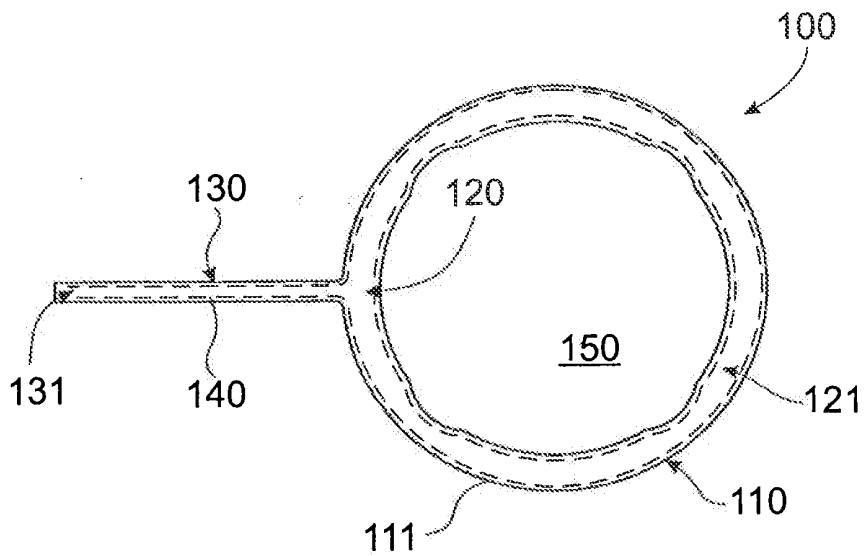

FIG. 1H (i)

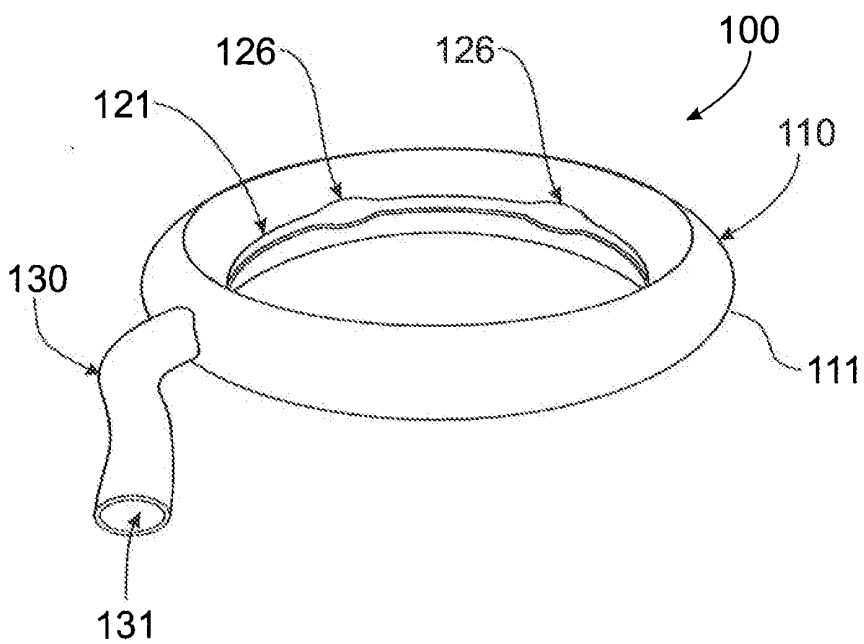

FIG. 1H (ii)

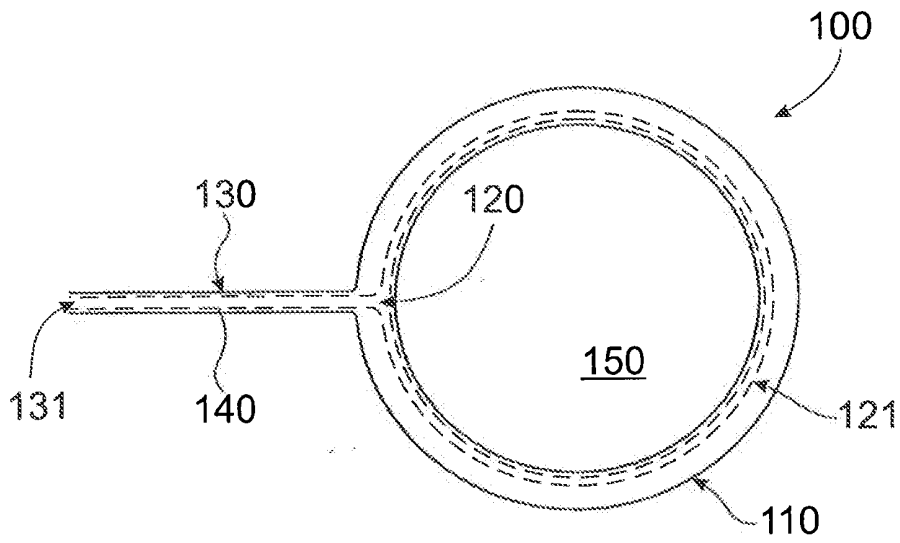

FIG. 1I (i)

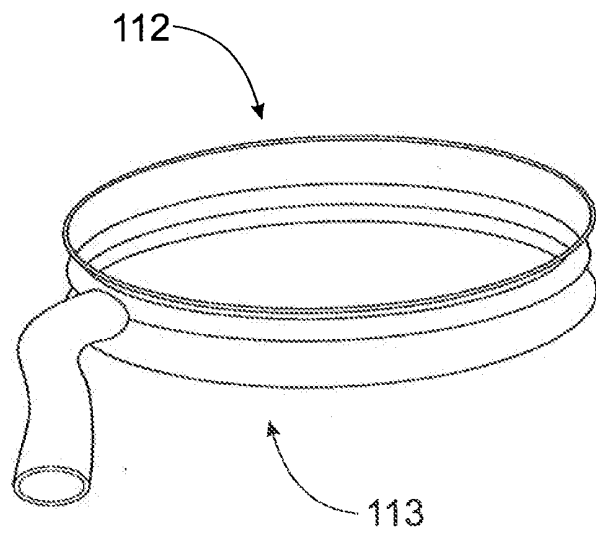

FIG. 1I (ii)

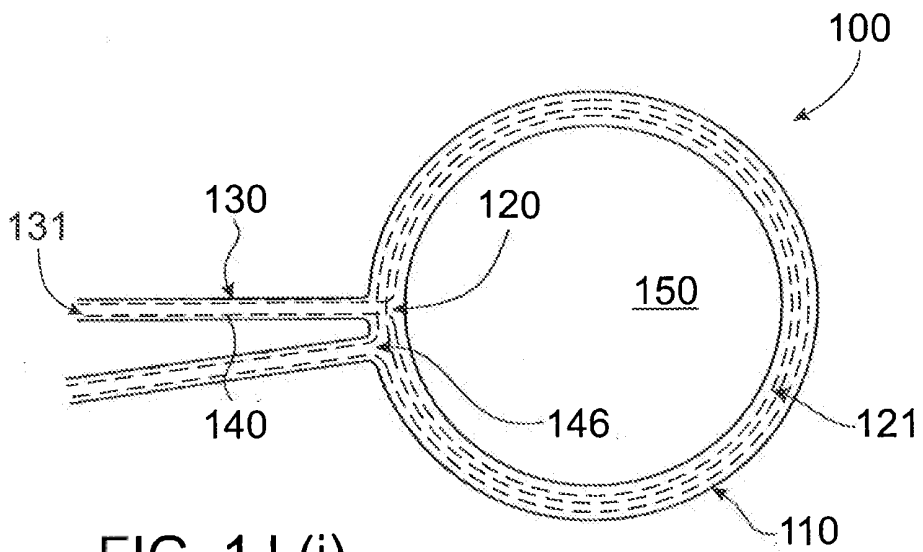

FIG. 1J (i)

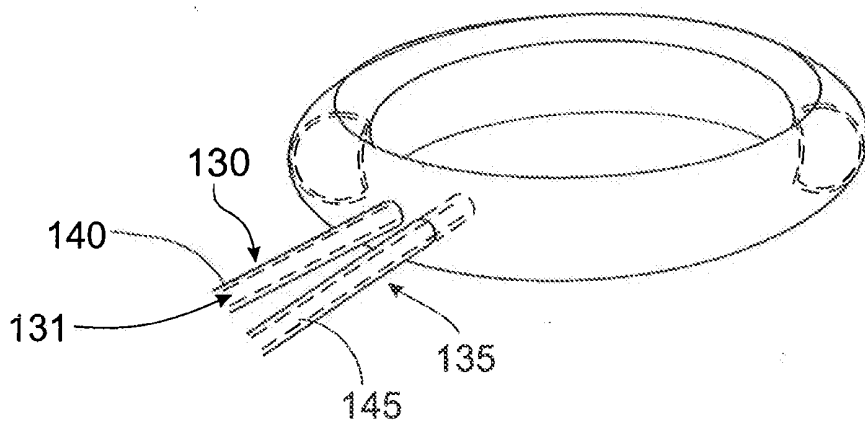

FIG. 1J (ii)

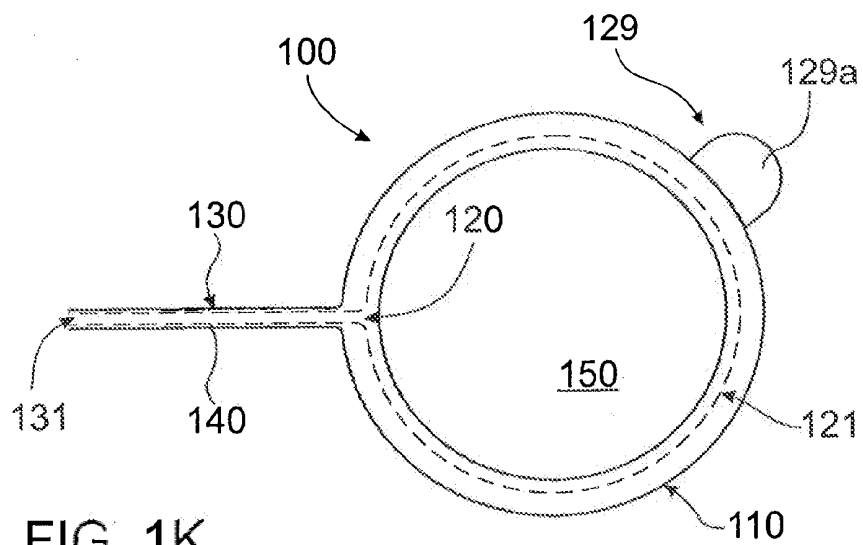

FIG. 1K

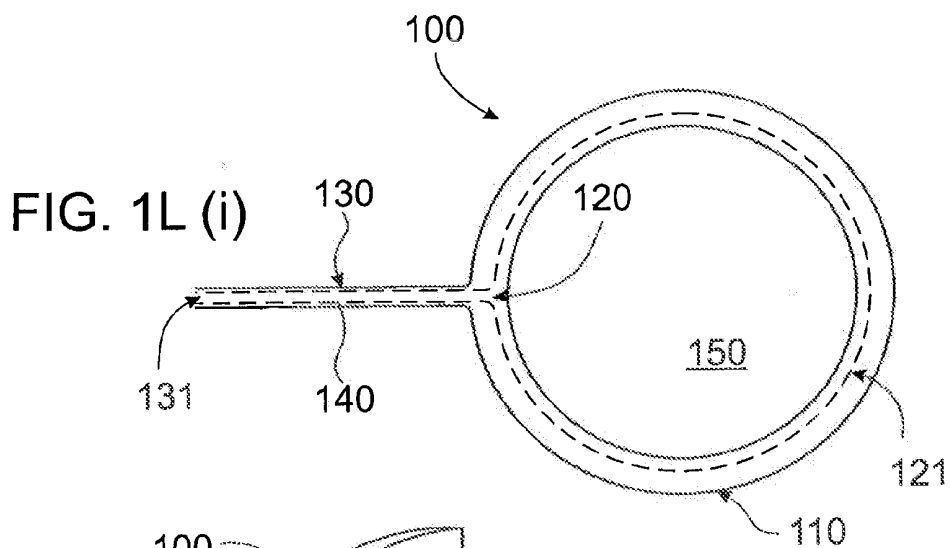

FIG. 1L (i)

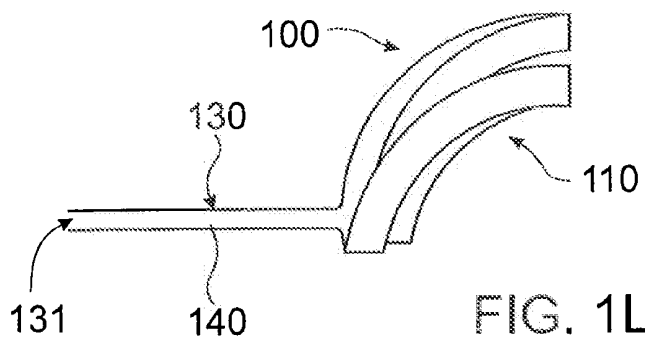

FIG. 1L (ii)

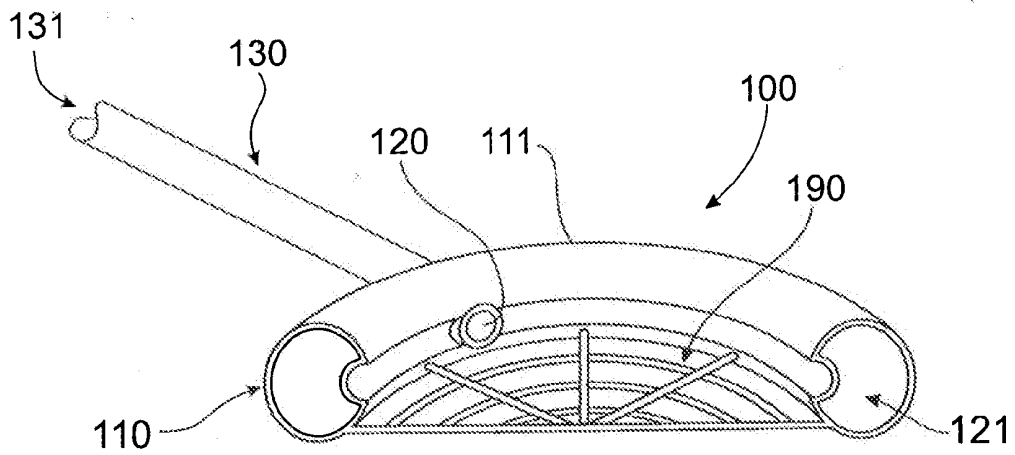

FIG. 1M (i)

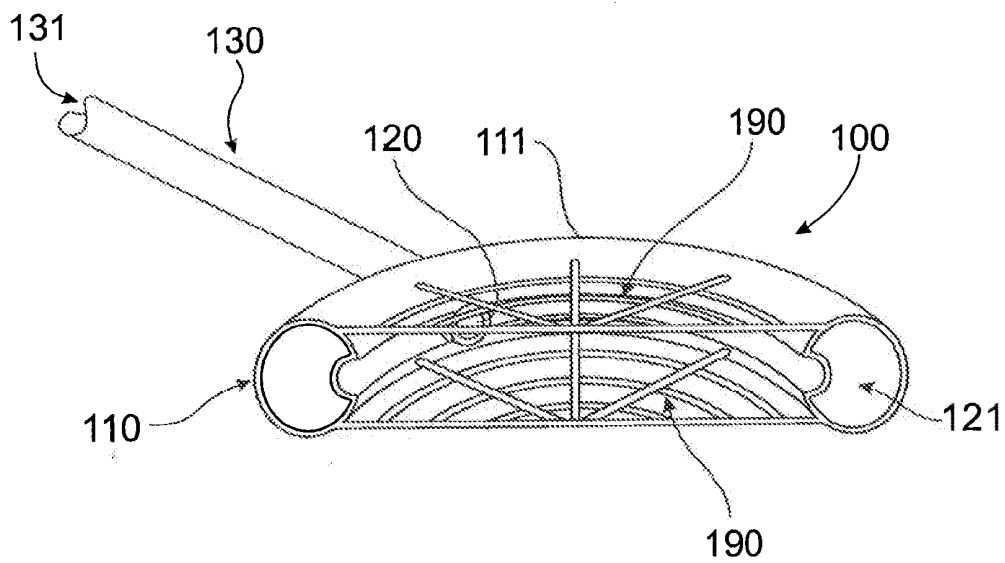

FIG. 1M (ii)

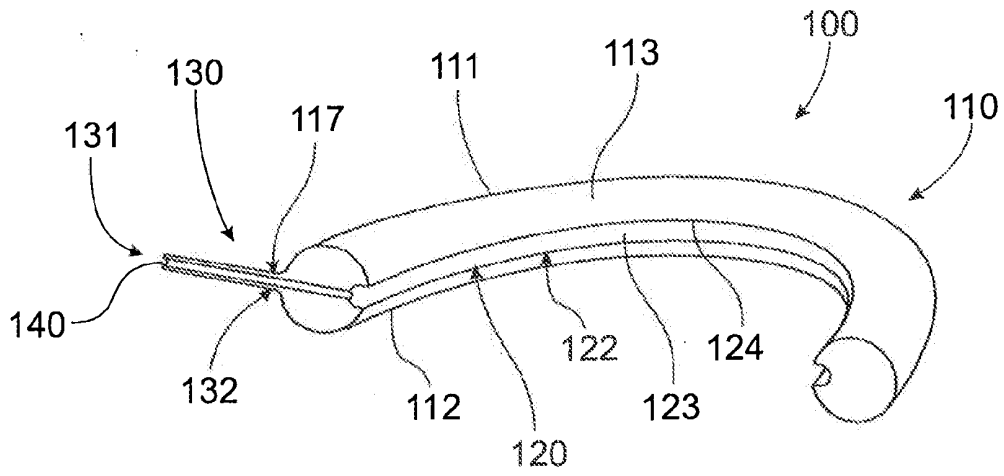

FIG. 2

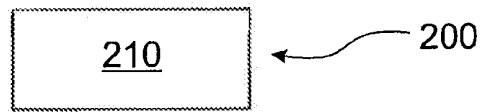

FIG. 3A

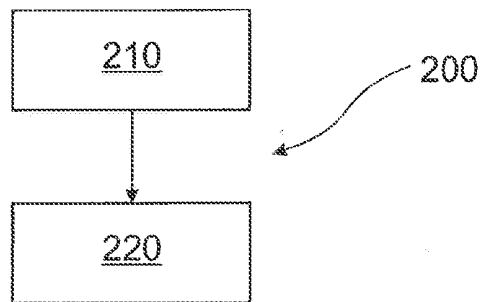

FIG. 3B

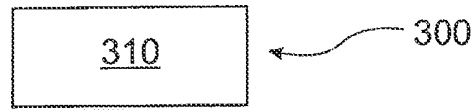

FIG. 4A

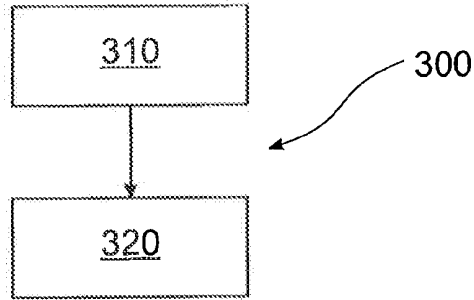

FIG. 4B

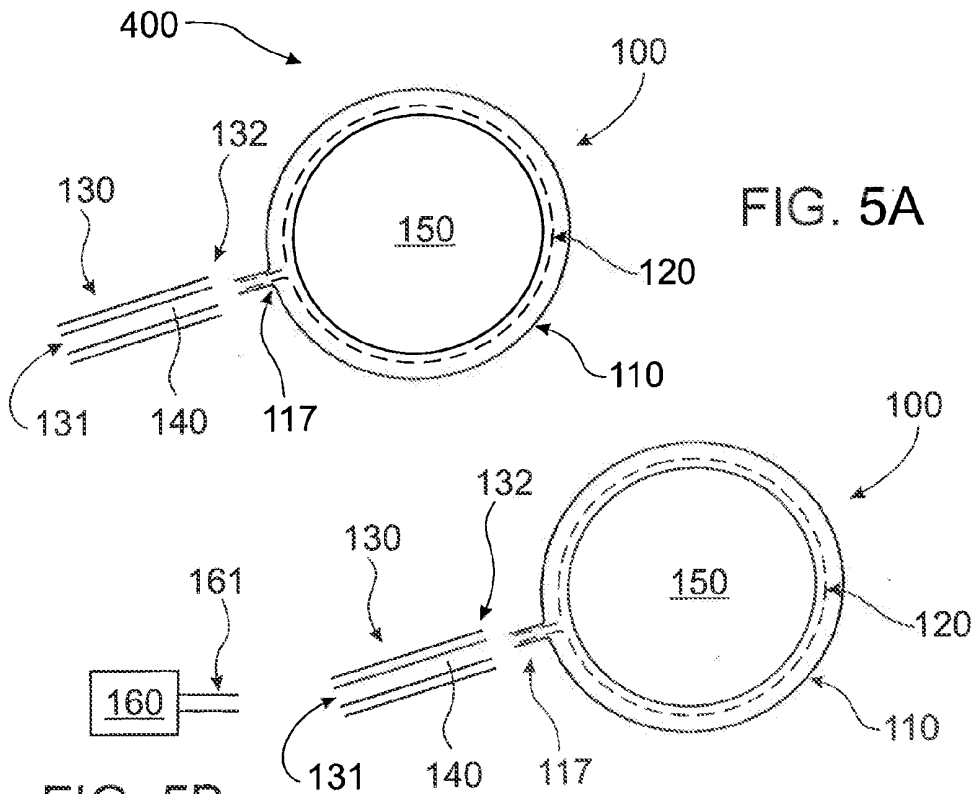

FIG. 5A

FIG. 5B

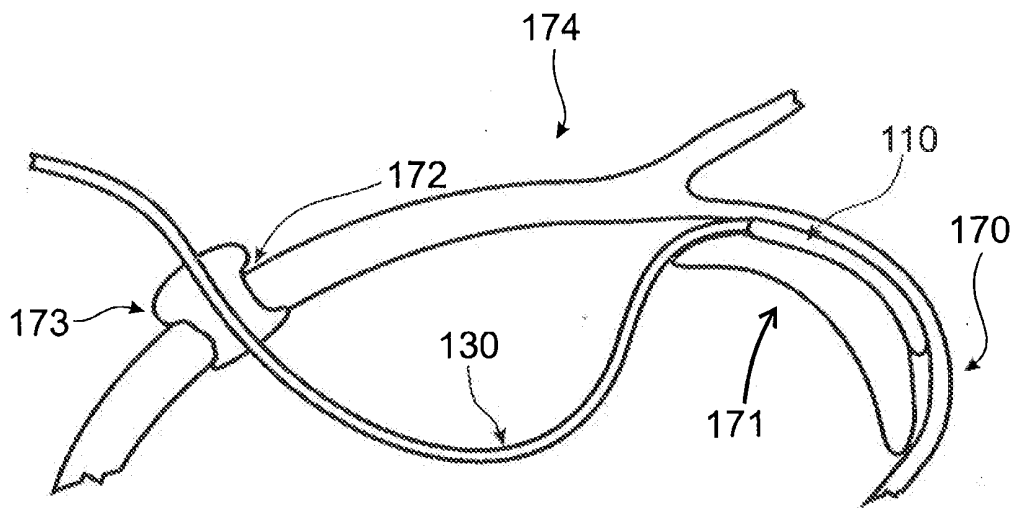

FIG. 6A

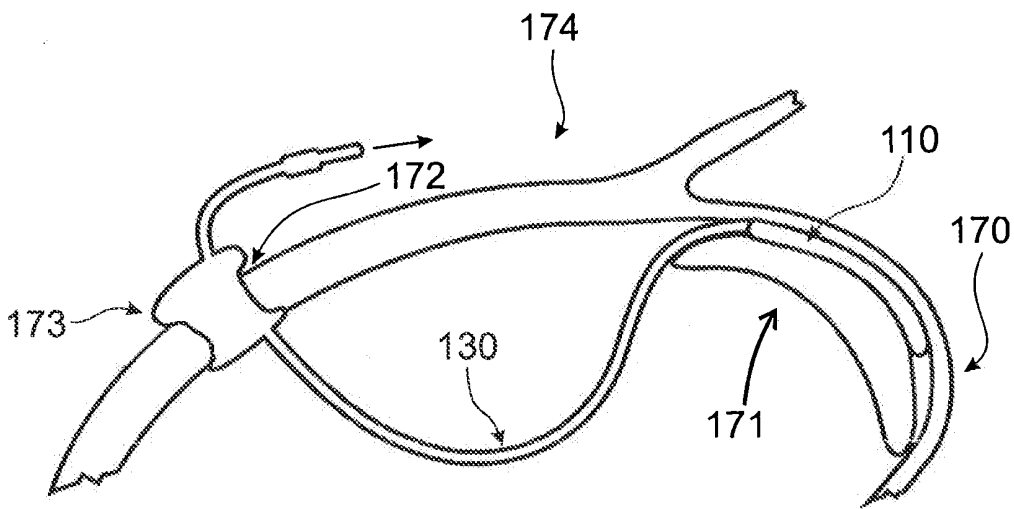

FIG. 6B

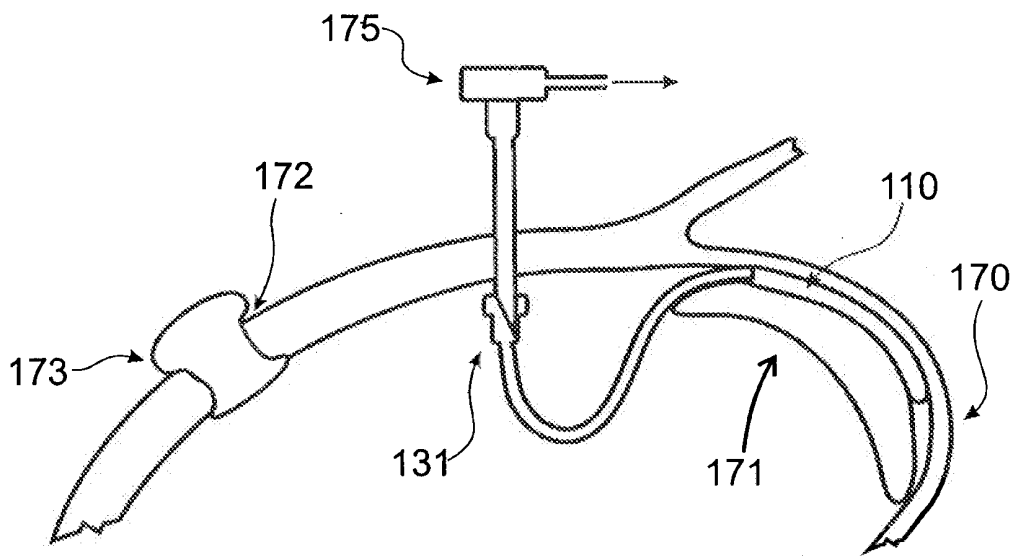

FIG. 6C

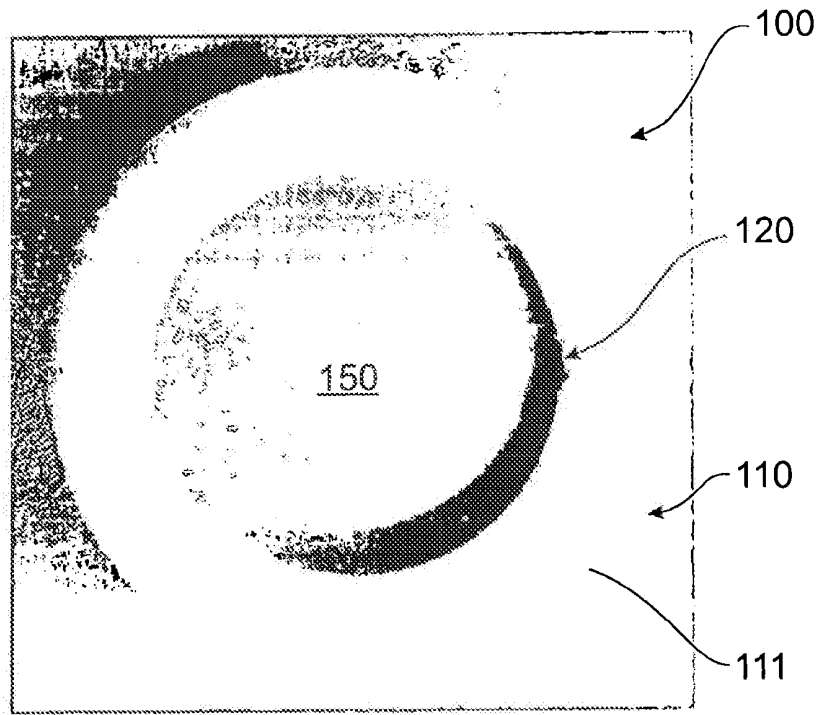

FIG. 7A

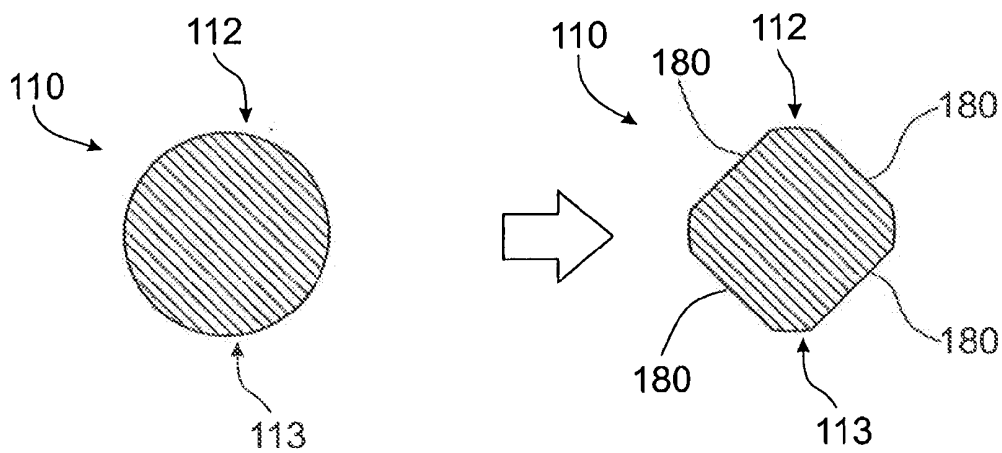

FIG. 7B

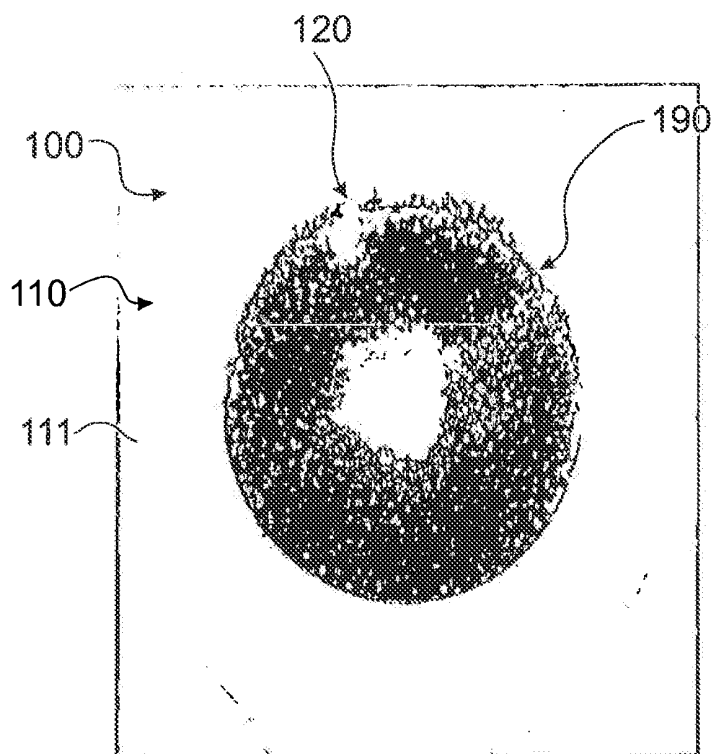

FIG. 8

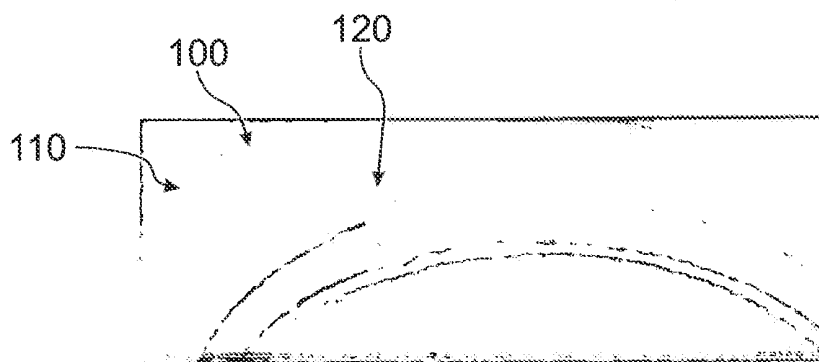

FIG. 9A

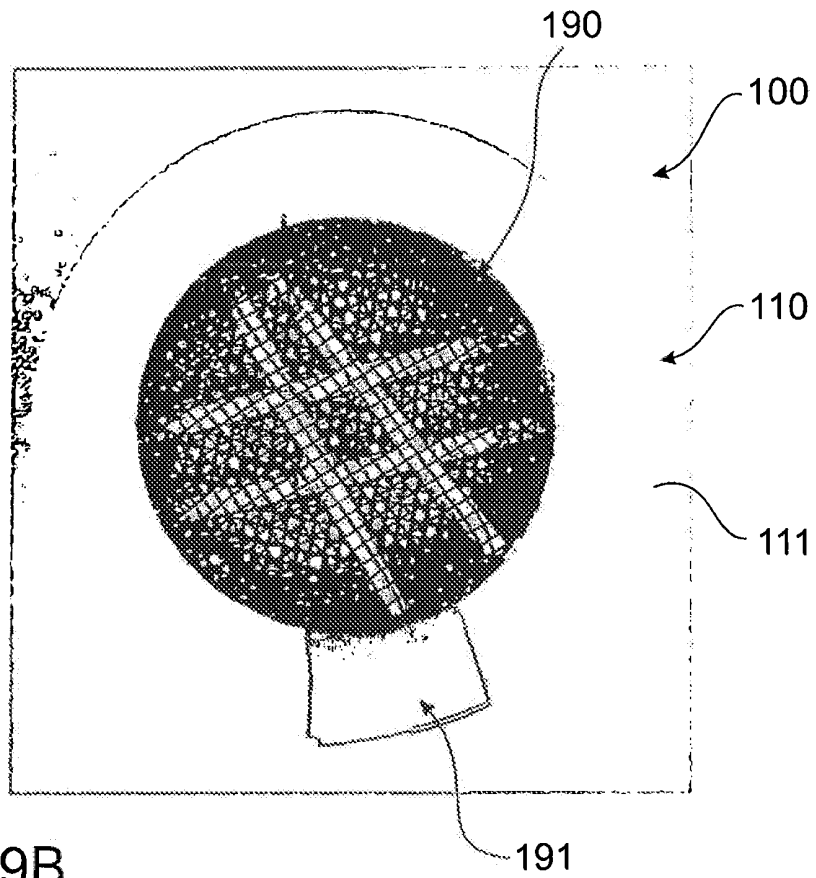

FIG. 9B

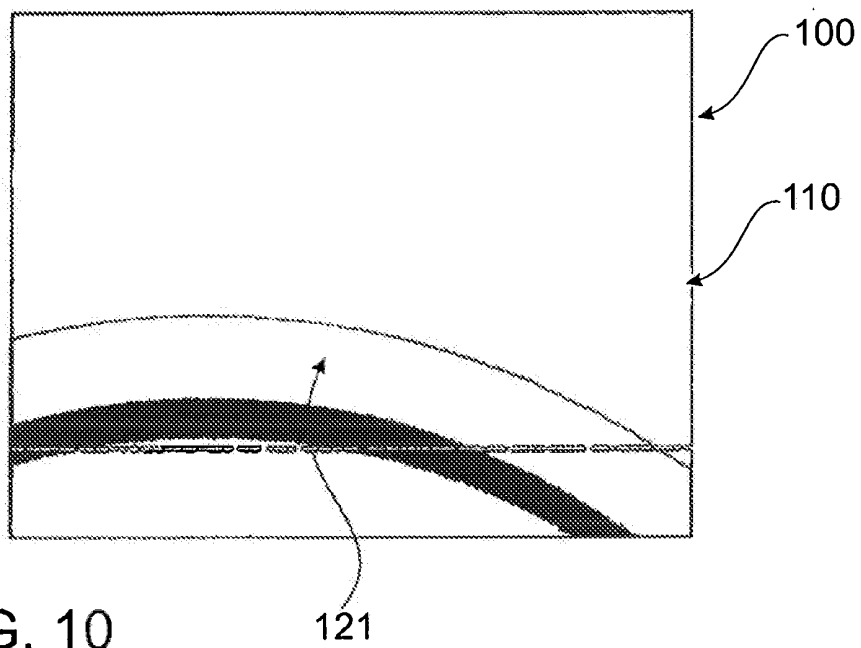

FIG. 10

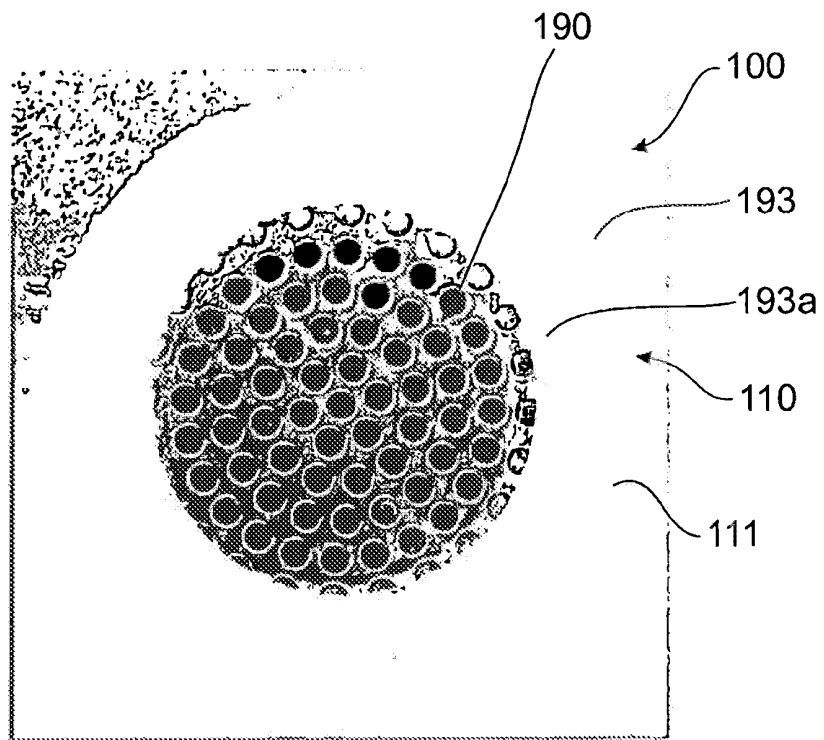

FIG. 11A

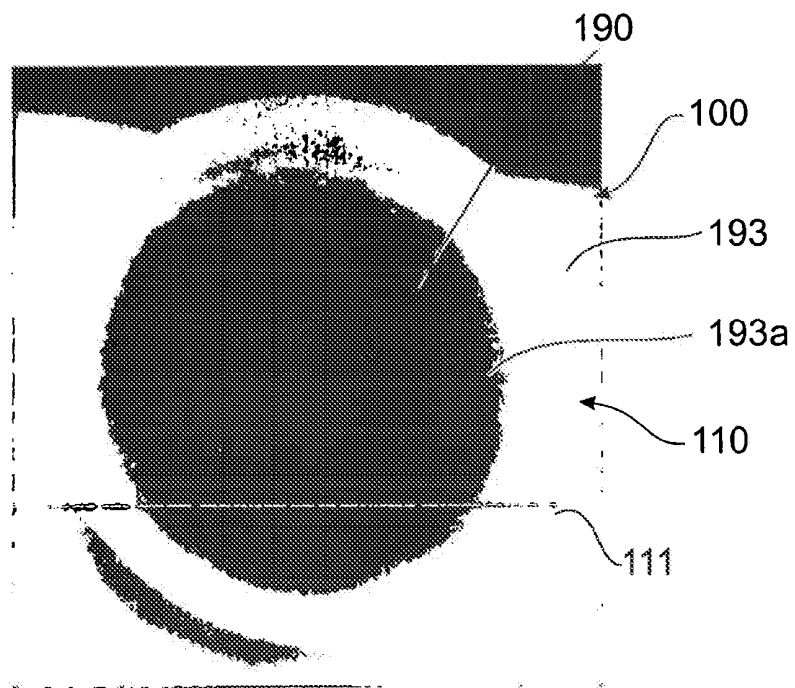

FIG. 11B

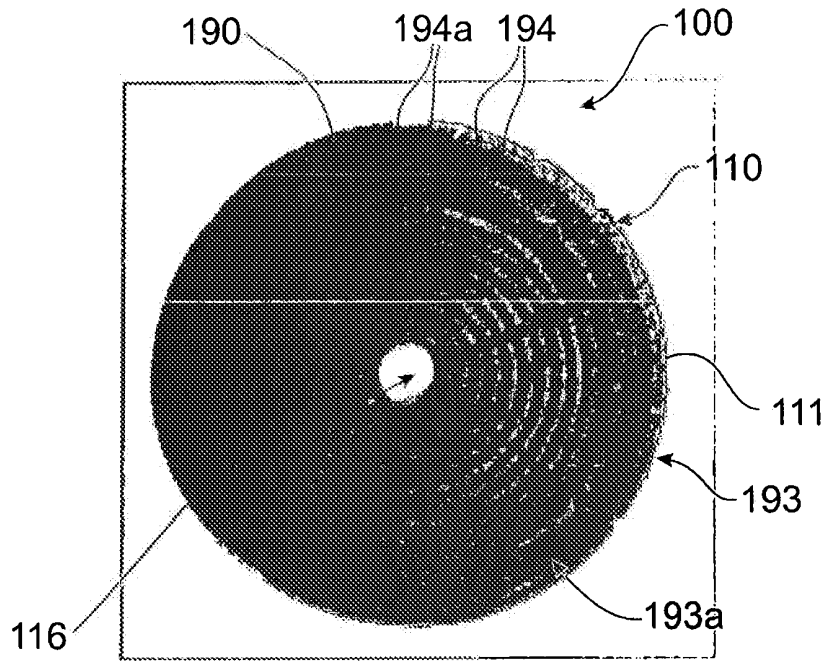

FIG. 12A

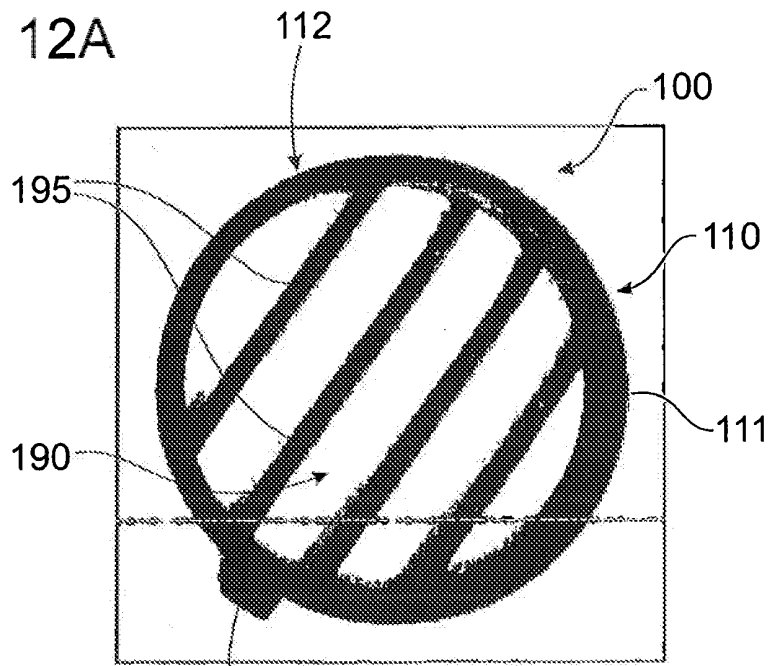

FIG. 12B

SUCTION RETRACTOR

FIELD OF THE INVENTION

[0001] The present invention relates to a suction retractor, method of surgery using a suction retractor, method of manufacturing a suction retractor and a kit comprising a suction retractor. In particular, but not exclusively, the present invention relates to a suction retractor that comprises a flexible continuous dam defining one or more inlet into an interior of the dam through which suction can be applied.

BACKGROUND TO THE INVENTION

[0002] Surgical procedures routinely require use of mechanical retractors to move a body part, tissue and/or an organ during the course of the surgery. These mechanical retractions require considerable skill to avoid causing trauma. Additionally, surgery is often carried out in a confined space that can become cluttered with such retractors.

[0003] The difficulty of using conventional mechanical retractors can be illustrated by briefly examining upper gastrointestinal surgery. Traditionally operating on abdominal organs required a "laparotomy" which is a large incision through the abdominal wall. One of the major advances in abdominal surgery over the last two decades has been laparoscopic surgery, which advantageously requires minimal access and thereby avoids the extent of trauma and scarring associated with a large incision. Laparoscopic surgery may be carried out by passing ports through multiple small incisions, or using Single Incision Laparoscopic Surgery (SILS) which utilizes only a single incision and single port. Advocates of SILS expound the advantages of reduced pain, trauma and scarring. Achieving adequate tissue retraction in SILS has proven to be a significant technical hurdle, as retractors that utilise the SILS port limit access of other instruments through that port. Suture techniques of retraction are time consuming and traumatic, whilst inserting a retractor through a separate port is not truly Single Incision Laparoscopic Surgery.

[0004] Accordingly there is a clear need for alternative retractors.

OBJECT OF THE INVENTION

[0005] It is an object of this invention to overcome and/or alleviate one or more of the above disadvantages of the prior art and/or provide the consumer with a useful or commercial choice.

[0006] It is a preferred object to provide a retractor that uses suction to retract one or more body part, tissue, organ or part thereof.

[0007] Further objects will be evident from the following description.

SUMMARY OF THE INVENTION

[0008] The present invention is broadly directed to providing a suction retractor as well as a method of surgery using a suction retractor, a method of making a suction retractor and a kit comprising a suction retractor. The present inventor has provided a novel and inventive retractor that simplifies many surgical procedures and can reduce the trauma and scarring consequent with surgical procedures such as, upper gastrointestinal surgery.

[0009] The simplification of many surgical methods that is preferably achieved by the suction retractor and methods of the invention is of significant advantage. Some of these

advantages are safety related through a reduction in the risk of surgical error and promotion of the uptake of less traumatic surgical methods. The present invention is also of significant advantage commercially because the suction retractor may be disposable thereby eliminating the cost and effort required with disinfecting and cleaning.

[0010] In a first aspect, although it need not be the only, or indeed the broadest aspect, the invention resides in a suction retractor comprising:

[0011] a flexible continuous dam which forms a closed loop of any shape and which defines one or more inlet, the one or more inlet opening into an interior of the closed loop, so that suction can be applied through the one or more inlet and into an interior of the continuous dam.

[0012] The suction retractor may also comprise a suction tube defining a suction channel, the suction tube attached to or attachable to the continuous dam and when attached the suction channel continuous with the one or more inlet.

[0013] In a second aspect the invention resides in a method of retracting one or more body part, tissue, organ or part thereof using the retractor of the first aspect.

[0014] In a third aspect the invention resides in a method of retracting one or more body part, tissue, organ or part thereof including:

[0015] applying suction through a retractor, the retractor comprising one or more inlet defined in a flexible continuous dam, the continuous dam forming a closed loop of any shape and the one or more inlet opening into an interior of the closed loop, to thereby form a seal to the one or more body part, tissue, organ or part thereof and to allow retraction of the one or more body part, tissue, organ or part thereof.

[0016] The method of the third aspect may also include the step of applying suction through a suction tube attached to the continuous dam wherein the suction tube defines a suction channel continuous with the one or more inlet.

[0017] In a fourth aspect the invention resides in a method of manufacturing a suction retractor including:

[0018] forming a flexible continuous dam which forms a closed loop of any shape and which defines one or more inlet opening into an interior of the closed loop to thereby manufacture the suction retractor.

[0019] The method of the fourth aspect may also include forming or attaching a suction tube defining a suction channel so that the suction channel and one or more inlet are continuous.

[0020] In a fifth aspect the invention resides in a system for retracting a body part, tissue, organ and/or part thereof comprising:

[0021] a flexible continuous dam forming a closed loop of any shape and defining one or more inlet through which suction can be applied, the one or more inlet opening into an interior of the closed loop; and

[0022] a suction tube defining a suction channel, the suction tube attached to or attachable to the continuous dam wherein when attached the suction channel is continuous with the one or more inlet.

[0023] The system according to the fifth aspect may also comprise an apparatus for applying suction through the suction tube and the one or more inlet.

[0024] In a sixth aspect the invention resides in a kit for retracting a body part, tissue, organ and/or part thereof comprising:

[0025] a flexible continuous dam forming a closed loop of any shape and defining one or more inlet through which

suction can be applied, the one or more inlet opening into an interior of the closed loop; and

[0026] a suction tube defining a suction channel, the suction tube attached to or attachable to the continuous dam wherein when attached the suction channel is continuous with the one or more inlet.

[0027] The kit according to the sixth aspect may also comprise an apparatus for applying suction through the suction tube and one or more inlet.

[0028] The kit according to the sixth aspect may also comprise instructions for use.

[0029] According to any of the above aspects the one or more inlet may extend into the interior area.

[0030] According to any of the above aspects the inlet may be recessed.

[0031] According to any of the above aspects the one or more inlet may open to a continuous channel extending throughout an interior of the closed loop.

[0032] According to any of the above aspects the continuous channel may comprise an open channel.

[0033] According to any of the above aspects the continuous channel may comprise a plurality of fenestrations.

[0034] According to any of the above aspects the continuous channel may be connected to a central rib.

[0035] The central rib may be connected to one or more radial rib.

[0036] The central rib may be fenestrated.

[0037] The one or more radial rib may be fenestrated.

[0038] According to any of the above aspects a guard may cover the one or more inlet.

[0039] According to any of the above aspects when the suction tube is attached to the continuous dam, the suction tube may be disposed laterally on the continuous dam.

[0040] When the suction tube is disposed laterally, the continuous dam and suction tube may be in a planar or substantially planar arrangement.

[0041] The planar or substantially planar arrangement may suitably allow conformational adaptation to the body part, tissue, organ or part thereof to which contact is made.

[0042] The continuous dam according to any of the above aspects may be planar or substantially planar.

[0043] According to any of the above aspects the flexibility of the continuous dam allows the dam to conformationally adapt to the body part, tissue, organ or part thereof to which contact is made.

[0044] The flexible continuous dam according to any of the above aspects may comprise a first compacted configuration for insertion and a second open configuration for retraction.

[0045] The flexible continuous dam according to any of the above aspects may transition from the compacted configuration to the open configuration by folding and unfolding, rolling and unrolling and/or collapsing and/or opening.

[0046] The transition may be manipulated by an opening mechanism operatively coupled to the retractor.

[0047] The retractor according to any of the above aspects may comprise one or more biasing member.

[0048] The biasing member may be a rod.

[0049] The rod may span the continuous dam.

[0050] The continuous dam according to any of the above aspects may be malleable.

[0051] The continuous dam according to any of the above aspects may have a shape memory.

[0052] The continuous dam according to any of the above aspects may be inflatable.

[0053] The inflatable continuous dam may comprise an inflation tube.

[0054] The continuous dam according to any of the above aspects may comprise opposed first and second walls.

[0055] The first and second walls may be partially separated by the continuous channel.

[0056] The first and/or second walls may inwardly angled.

[0057] The first and/or second walls may be outwardly angled.

[0058] The first and/or second walls may be tapered.

[0059] The first and/or second walls may comprise one or more reinforcement members.

[0060] The one or more reinforcement members may be collocated with the fenestrations in the continuous channel.

[0061] The continuous dam according to any of the above aspects may comprise a perforated membrane. The perforated membrane may comprise a central orifice. The perforated membrane may span at least a part of an area defined by dam walls.

[0062] The retractor according to any of the above aspects may comprise one or more projection that can be grasped and manipulated so as to secondarily retract or re-position the tissue, organ and/or part thereof.

[0063] According to any of the above aspects the continuous channel may comprise an opening to an area defined by the first and second dam walls.

[0064] According to any of the above aspects the first and/or second walls may comprise a convex outer surface.

[0065] The first and/or second walls may comprise a chamfer.

[0066] The first and/or second walls may comprise ridges of progressive or tiered heights.

[0067] The first and/or second wall may comprise one or more lip.

[0068] The one or more lip may be pliant.

[0069] The one or more lip may be rigid.

[0070] The one or more lip may be smooth.

[0071] The one or more lip may be turreted.

[0072] In a preferable embodiment the first and/or second wall may comprise a pliant outer lip.

[0073] In another preferable embodiment the first and/or second wall may comprise a rigid turreted inner lip.

[0074] In still another preferable embodiment the first and/or second wall may comprise a pliant outer lip and a rigid turreted inner lip.

[0075] According to any of the above aspects the continuous channel may comprise a gutter or furrow.

[0076] According to any of the above aspects the gutter or furrow may comprise a C-shaped.

[0077] According to any of the above aspects the continuous channel may comprise a concave surface.

[0078] According to any of the above aspects the continuous dam may be circular, amorphous, triangular or shaped to conform to a body part, tissue, organ and/or part thereof to be retracted.

[0079] According to any of the above aspects a spacer may be comprised within the interior of the continuous dam.

[0080] The spacer may comprise a plurality of spacing ribs.

[0081] One or more spacing ribs may be radial or concentric.

[0082] One or more spacing ribs may be parallel.

[0083] One or more spacing ribs may be transverse.

[0084] The spacer may comprise a webbing.

[0085] The webbing may be positioned above and/or below the inlet or continuous channel.

[0086] According to any of the above aspects, suction applied into interior area is sufficient to effectively hold or secure one body part, tissue, organ or part thereof to another body part, tissue, organ or part thereof through retractor. This holding or securing preferably also actuates a retraction as the one body part, tissue, organ or part thereof is moved toward the other body part, tissue or organ.

[0087] Further features of the present invention will become apparent from the following detailed description.

[0088] In this specification, the terms “comprises”, “comprising”, “include” and “including” or similar terms are intended to mean a non-exclusive inclusion, such that a method, system or apparatus that comprises a list of elements does not include those elements solely, but may well include other elements not listed.

BRIEF DESCRIPTION OF THE DRAWINGS

[0089] In order that the present invention may be readily understood and put into practical effect, reference will now be made to the accompanying illustrations, wherein like reference numerals are used to refer to like elements, and wherein:

[0090] FIG. 1A(i) is a schematic diagram of a suction retractor according to a first embodiment of the invention;

[0091] FIGS. 1A(ii), 1B, 1C, 1D, 1E(i), 1E(ii), 1F(i), 1F(ii), 1G(i), 1G(ii), 1H(i), 1H(ii), 1I(i), 1I(ii), 1J(i), 1J(ii), 1K, 1L(i), 1L(ii), 1M(i) and 1M(ii) are schematic diagrams of suction retractors according to other embodiments of the invention;

[0092] FIG. 2 is a schematic diagram showing a cut-away view of the suction retractor according to one embodiment of the invention;

[0093] FIGS. 3A and 3B show embodiments of the method of surgery according to the invention;

[0094] FIGS. 4A and 4B are schematic diagrams showing embodiments of the method of manufacturing a retractor according to the invention;

[0095] FIGS. 5A and 5B are schematic diagrams showing embodiments of the kit according to the invention; and

[0096] FIGS. 6A, 6B and 6C are schematic diagrams, showing cut-away views of the suction retractor according to the first embodiment in use.

[0097] FIGS. 7A, 7B, 8, 9, 9A, 9B, 10, 11A, 11B, 12A, 12B, 12C and 12D show further embodiments of a suction retractor according to the invention.

DETAILED DESCRIPTION OF THE INVENTION

[0098] The invention relates, at least in part, to a retractor which uses suction to retract a body part, organ, tissue and/or part thereof. The present inventor has provided a novel and inventive retractor that simplifies many surgical methods. There are many advantages associated with the present invention including being compatible with true SILS as well as simplicity and rapidity of use. Additionally, the suction retractor, which advantageously may be used to retract any body part, tissue, organ or part thereof, is of further advantage because suction may be less traumatic than traditional mechanical manipulations. The suction retractor allows the necessary force to be more evenly distributed around the surface of the body part, tissue, organ and/or part thereof to be retracted and thereby minimizes the risk of trauma.

[0099] Further the suction retractor of the invention may be disposable and cheap to manufacture.

[0100] The present inventor has provided a novel retractor designed to achieve organ retraction in surgery, with particular application in single incision or conventional laparoscopic surgery. The novel retractor of the invention comprises an enclosed dam within which suction forces are applied. In one application the dam is placed in between the viscera (nominally liver and diaphragm), suction applied, and apposition of the viscera thereby maintained. It should be noted that, in the case of the liver and diaphragm, the dam is merely maintaining the normal anatomical relationship between these viscera, whereas normally the liver would drop down away from the diaphragm under influence of gravity at laparoscopic surgery.

[0101] The inventor does caution that the suction retractor of the invention may not be strong enough in cases where a large force must be applied to achieve the necessary retraction. These situations such as, where there are adhesions under a liver or very large organs, are in the minority and best dealt with using traditional mechanical retraction.

[0102] As used herein “flexible” means capable of bending. As will be elucidated below the flexibility of the retractor of the invention means the retractor can transition from a first compacted configuration to a second open configuration.

[0103] FIG. 1A(i) shows one embodiment of the suction retractor 100 according to the invention. Suction retractor 100 comprises a continuous dam 110 that defines an inlet 120 through which suction is applied from suction tube 130. Inlet 120 comprises an opening or orifice into interior area 150 from suction channel 140 comprised in suction tube 130.

[0104] As will be explained below a guard 191 may partially cover the one or more inlet 120 so that suction does not draw matter such as, a body part, organ or part thereof to be retracted, into one or more inlet 120.

[0105] In another embodiment inlet 120 may be recessed into dam 110 to prevent matter being draw into inlet 120.

[0106] FIG. 1A(ii) shows another embodiment of the suction retractor 100 in which inlet 120 opens to a continuous channel 121 through which suction can be applied. The structure of continuous channel 121 is discussed in detail below with reference to FIG. 2.

[0107] As shown in FIGS. 1A(i) and 1A(ii), continuous dam 110 forms a loop 111 which surrounds and defines an interior area 150. Using retractor 100 suction can be applied into interior area 150.

[0108] As will be understood the suction applied into interior area 150 is sufficient to effectively hold or secure one body part, tissue, organ or part thereof to another body part, tissue, organ or part thereof through retractor 100. This holding or securing preferably also actuates a retraction as the one body part, tissue, organ or part thereof is moved toward or held adjacent to the other body part, tissue or organ.

[0109] In the embodiment shown in FIG. 1A(i) inlet 120 does not extend into interior area 150. In other embodiments inlet 120 extends into interior area 150.

[0110] Suction retractor 100 may also comprise a flexible suction tube 130 that defines a suction channel 140. As shown in FIG. 1A(i) and FIG. 1A(ii) suction channel 140 is continuous with inlet 120 and continuous channel 121, respectively. Suction tube 130 also comprises proximal tube port 131 which may be attached to an apparatus for applying suction through suction channel 140.

[0111] In another embodiment suction tube **130** is removably attachable to continuous dam **110**. This allows suction tube **130** to be removed and attached as required.

[0112] Continuous dam **110** is planar or substantially planar. As can be seen in FIGS. 6A-6C the planar or substantially planar shape allows continuous dam **110** to be positioned or sandwiched between two adjacent and/or abutting body parts, tissues, organs and/or parts thereof. The flexible and planar or substantially planar arrangement suitably allows conformational adaptation to the body part, tissue, organ or part thereof being retracted.

[0113] To enable positioning of continuous dam **110**, suction tube **130** may be disposed laterally on continuous dam **110**. This lateral arrangement results in retractor **100** having a planar or substantially planar shape as shown in the embodiments illustrated in FIGS. 1A(i), 1A(ii), 1B, 1C, 1D and 1E(i) and 1E(ii).

[0114] Dam **110** of retractor **100** shown in FIGS. 1A(i) and 1A(ii) is annular. Based on the teachings herein a skilled person is readily able to select other suitable shapes for dam **110**. For example, FIGS. 1B and 1C show embodiments in which dam **110** is amorphous and triangular, respectively. Other suitable shapes for dam **110** include rectangular, square, pentagonal and hexagonal. Dam **110** may be shaped to conform to a particular body part, tissue, organ and/or part thereof to be retracted.

[0115] FIG. 1D shows another embodiment of retractor **100** comprising a membrane **114**. Membrane **114** comprises multiple perforations **115** and defines a central orifice **116**. To avoid cluttering FIG. 1D not all perforations **115** are labelled. The perforated membrane spans at least a part of the interior area **150** defined by walls **112**, **113** (see FIG. 2 and further description below):

[0116] Perforated membrane **115** is preferably thinner than dam **110**.

[0117] FIG. 1E(i) shows a top view of another embodiment of retractor **100**. Retractor **100** shown in FIGS. 1E(i) and 1E(ii) comprises a fenestrated continuous channel **121**. By fenestrated is meant a series of fenestrations or openings or windows **121a** along the length of continuous channel **121**. In other embodiments, for example those shown in FIGS. 1A(ii), 1B, 1C, 1D and FIG. 2, continuous channel **121** is open. In the embodiment shown in FIG. 1E, continuous channel **121** is connected to a central rib **125** which in turn is connected to one or more radial ribs **126**. Both central rib **125** and the one or more radial ribs **126** are fenestrated to supply suction into interior area **150**. Ribs **125**, **126** divide the interior area **150** into sections **150a**.

[0118] In the embodiment shown in FIGS. 1E(i) and 1E(ii) the proximal sections of continuous channel **121**, that is, those sections **121-1** and **121-2** extending from inlet **120** to the first radial rib **126** are closed. The distal sections of continuous channel **121**, that is, those central sections **121-3** and **121-4** extending between the radial ribs **126**; and those end sections **121-5** and **121-6** extending between the radial ribs **126** and the central rib opposite inlet **120**; comprise a fenestrated channel **121**. In other embodiments the distal sections **121-3**, **121-4**, **121-5** and **121-6** are open comprising a gutter or furrow **122** and do not comprise fenestrations **121a**. In still other embodiments the entire continuous channel **121** is fenestrated.

[0119] FIG. 1E(ii) shows a cut-away perspective view of retractor **100** shown in FIG. 1E(i) in which ribs **125**, **126** are omitted. The cut-away view shows the first and second walls

112, **113** to comprise an outer lip **193** and an inner lip **193a**. Outer lip **193** is pliant to conform to the body part, tissue or organ to be contacted and to which a seal is to be made. Inner lip **193** is more rigid and turreted to provide support for the dam **110** while gripping to the body part, tissue or organ to be contacted. The turreted lip **193a** comprises a series of turrets or spaced apart teeth **193b** which are separated by a series of valleys **193c**.

[0120] As will be elucidated below with reference to FIGS. 7 and 9, a spacer **190** may be inserted into interior area **150** to assist in keeping parts on opposite sides of continuous dam **110** separated.

[0121] Spacer **190** may be of any suitable shape and material. The spacer **190** may comprise a foam material or a mesh material. Preferably spacer **190** is a mesh. As will be described below spacer **190** may comprise a plurality of radial or concentric spacing ribs **194**, one or more parallel spacing ribs **195** and/or one or more transverse spacing rib **196**.

[0122] FIGS. 1F(i) and 1F(ii) show top and perspective views, respectively of another embodiment of retractor **100** comprising biasing member **127**. For sake of simplicity channel **121** has been omitted from FIG. 1F(ii). In the embodiment shown in FIGS. 1F(i) and 1F(ii) biasing member **127** is a rod **127a** that spans continuous dam **110** and provides a bias from the compacted configuration to the open configuration. The bias imparts good spring back from the compacted configuration to the open configuration. The biasing member **127** may be operated by the opening mechanism. Based on the teaching herein a skilled person is readily able to select other suitable biasing members **127**. In other embodiments retractor **100** comprises a plurality of biasing members.

[0123] FIGS. 1G(i) and 1G(ii) show top and perspective views, respectively of yet another embodiment of retractor **100** comprising inwardly-angled or V-shaped walls **112**, **113** which angle inwardly towards interior area **150**. Inwardly-angled walls **112**, **113** improve the conformational fit with the body part, tissue or organ being contacted and may improve and/or strengthen the seal.

[0124] FIGS. 1H(i) and 1H(ii) show top and perspective views, respectively of a further embodiment in which retractor **100** comprises reinforcement members **126** positioned in channel **121**. Reinforcement members **126** are substantially more rigid than continuous dam **110** and will maintain an open configuration under compressive force that would collapse channel **121**. The reinforcement members may be collocated with the plurality of openings or fenestrations **124**. The reinforcement members may prevent loss of suction if walls **112**, **113** collapse.

[0125] The embodiment of retractor **100** illustrated in top and perspective views of FIGS. 1I(i) and 1I(ii), respectively, has walls **112**, **113** which are outwardly angled, i.e. angled away from interior area **150**, and which may create a suction-cup like effect to increase suction. Advantageously, by outwardly angling walls **112**, **113** the surface area of contact is increased and the seal may be improved.

[0126] Accordingly, to any suitable embodiment of retractor **100**, to improve the seal, walls **112**, **113** may be tapered. The improved sealing effect of tapered walls **112**, **113** will be particularly apparent with inwardly and outwardly angled walls **112**, **113**, like those embodiments shown in FIGS. 1G and 1I.

[0127] FIGS. 1J(i) and 1J(ii) show top and perspective views, respectively of an embodiment of retractor **100** which transitions to an open configuration by being inflated from its

collapsed configuration. Inflation and deflation occurs through inflation tube 135 which defines inflation channel 145 and opens into inflation inlet 136 in dam 110. Inflatable retractor 100 would advantageously have good surface contact and conformation to a sealing surface. An inflatable retractor 100 would also provide a relatively soft contact surface to reduce or limit any damage to the body part, tissue, organ or part thereof contacted by inflatable retractor 100.

[0128] FIG. 1K shows an embodiment of retractor 100 which comprises a projection 129 that can be grasped and manipulated so as to secondarily retract or re-position the tissue, organ and/or part thereof. In the embodiment shown in FIG. 1K, projection 129 is a tab 129a extending from dam 110 and is located distal to suction tube 130. In other embodiments retractor 100 may comprise a plurality of projections 129 positioned at various locations on dam 110.

[0129] As shown in FIG. 2 continuous dam 110 comprises first wall 112 and second wall 113 which are joined and opposed to each other. Walls 112 and 113 join at substantially the middle of dam 110, i.e. in embodiments of retractor 100 comprising central channel 121, walls 112, 113 are partially separated by continuous channel 121. In the embodiment of retractor 100 shown in FIG. 2 first and second walls 112, 113 comprise a hemi-spherical cross-section and comprise a curved or convex outer surface that does not have any edges and thereby minimizes the risk of retractor 100 causing any internal damage. Based on the teaching herein a skilled person is readily able to select alternative cross-sectional profiles for walls 112, 113. For example, walls 112, 113 may comprise a chamfer 180, see FIG. 7B or may comprise ridges of progressive or tiered height.

[0130] Additionally, as described above with reference to FIGS. 1E(i) and 1E(ii) and below with reference to FIGS. 11A and 11B, walls 112, 113 may comprise a lip 193 and or an inner lip 193a.

[0131] In other embodiments the outer surface of walls 112, 113 are not curved and instead are flat or planar. The flat surfaces may have edges or corners or may have tapered edges. Based on the teaching herein a skilled person is readily able to chose a suitable shape for walls 112, 113.

[0132] In the embodiment shown in FIG. 2, continuous channel 121 is a C-shaped gutter or furrow 122 that comprises a concave surface 123. In other embodiments channel 121 may have another shape such as, a V-shape. A skilled person is readily able to select an alternate shape for channel 121.

[0133] As shown in FIG. 2 to generate suction in interior area 150, retractor 100 comprises an opening 124 in continuous channel 121 which opens out to interior area 150. In the embodiment shown in FIG. 1A(ii) and FIG. 2 a single opening 124 runs the length of continuous channel 121. In the embodiment shown in FIGS. 1E(i) and 1E(ii) retractor 100 comprises a plurality fenestrations 121a which extend only part of the length of continuous channel 121. Each fenestration 121a has its own opening 124a. The plurality of fenestrations 121a and associated openings 124a may be spaced equidistantly and intermittently along the length of fenestrated continuous channel 121 so as to obtain an even suction.

[0134] Opening 124 allows suction applied through continuous channel 121 to form a seal between two internal structures which suction retractor 110 is sandwiched between. Once this seal has been formed the internal structures may be retracted.

[0135] In the embodiments shown in FIGS. 1D, 1E(i) and 1E(ii) the suction to the body part, tissue, organ or part thereof is applied through multiple perforations 115 and multiple openings 124a, respectively.

[0136] The continuous dam 110 shown in FIGS. 1A(i), 1A(ii) and 1D has a diameter of 50 mm, with a suitable range of 30-80 mm to allow for paediatric to "super-sized" patient applications. The continuous dam 110 shown in FIG. 1B has a longest span of 60 mm and a shortest span of 40 mm. The length of the sides of dam 110 shown in FIG. 1C is 50 mm.

[0137] Walls 112 and 113 have a thickness of 3 mm each, comprising a combined thickness of 6 mm. A suitable range for thickness of walls 112 and 113 is 3-6 mm.

[0138] Perforated membrane 114 has a thickness of 4 mm. A suitable range for thickness of perforated membrane 114 is 3-6 mm.

[0139] Perforations 115 have a diameter of 4 mm. A suitable range for the diameter of perforations 115 is 2-5 mm.

[0140] Orifice 116 has a diameter of 10 mm. A suitable range for the diameter of orifice 116 is 2 mm-30 mm.

[0141] Continuous channel 121 has a diameter of 2 mm. A suitable range for the diameter of continuous channel 121 is 1-3 mm.

[0142] Opening 124 has a width of 2 mm. A suitable range for opening 124 is 1-3 mm.

[0143] Suction tube 130 has a diameter of 5 mm and suction channel 140 has a diameter of 3 mm. Suitable ranges for the diameter of suction tube 130 and suction channel 140 are 4-7 and 3-5 mm, respectively.

[0144] Suction tube has a length of 50 cm. The length may be tailored to the particular surgical technique and is likely to be in the range of 10 cm-3 metres.

[0145] Based on the teachings herein a skilled person is readily able to select suitable values for the dimensions discussed above. It is also to be understood the dimensions included herein are indicative only and the invention is not so limited.

[0146] As mentioned above, in order to be inserted through a tract in laparoscopic surgery retractor 100 is preferably flexible and/or collapsible. As a result of this flexibility and/or collapsibility, retractor 100 may have a first compacted configuration for insertion and a second open configuration for contraction.

[0147] To transition between the compacted configuration and the open configuration retractor 100 may be folded and unfolded, rolled and unrolled and/or collapsed and released. Preferably the transition is reversible.

[0148] FIG. 1L(i) shows one embodiment of the retractor 100 in an open configuration and FIG. 1L(ii) shows the retractor of FIG. 1L(i) in a compacted configuration. The compacted configuration in FIG. 1L(ii) is a rolled configuration.

[0149] The transition may be accomplished manually or automatically by operatively coupling an opening mechanism (not shown) to retractor 100. The opening mechanism may act on the biasing member 127. From the teaching herein the skilled person is readily able to select a suitable opening mechanism.

[0150] In addition to being malleable retractor 100 may also have a shape memory. This shape memory allows the retractor to return to its original and intended shape after being compacted for example, to fit through a surgical port or to be positioned for retraction.

[0151] To achieve the desired level of malleability dam 100 is comprised of a suitable biocompatible medical grade synthetic material such as, soft and/or pliable silicones and/or plastics.

[0152] As will be discussed below the malleability enables retractor 100 to be folded into a compact size to allow insertion through a surgical port. The malleability also aids retractor 100 to adapt to the shape of the body part, tissue, organ and/or part thereof to be retracted. This feature of the invention advantageously improves the suction applied.

[0153] FIG. 1M(i) shows yet another embodiment of the retractor 100 of the invention in which spacer 190 is in the form of a webbing. In FIG. 1M(i) the webbing is located on one side, e.g. below, or in use an inferior surface, of continuous channel 121. In FIG. 1M(ii) the webbing is located on both sides, e.g. above and below, or in use an inferior surface and a superior surface, of continuous channel 121. The webbing, like other spacers 190, is useful in preventing matter from being drawn into inlet 120 or channel 121.

[0154] Retractor 100 may also be used in conventional surgical techniques. In these techniques there is no requirement for retractor 100 to be inserted through a surgical port and in such instances retractor 100 may have a size as large as required to retract the body part, tissue, organ and/or part thereof of interest.

[0155] Retractor 100 may be used to retract any body part, tissue, organ or part thereof. For example, retractor 100 may be used to retract either the left or right lobe of the liver during SILS, or any suitable body part, tissue, organ or part thereof.

[0156] As noted above, the invention also provides a method 200 of retracting one or more body part, tissue, organ or part thereof using retractor 100.

[0157] According to one embodiment of method 200 shown in FIG. 3A in step 210 suction is applied through retractor 100 to form a seal to the one or more body part, tissue, organ or part thereof to thereby allow retraction of the one or more body part, tissue, organ or part thereof.

[0158] Before applying the suction the retractor 100 is positioned on or sandwiched between the body part, tissue, organ or part thereof to be retracted and another structure so that an adequate suction and vacuum can be created in order to facilitate retractions. The another structure may be another body part; tissue, organ and/or part thereof.

[0159] As shown in FIG. 3B, method 200 may also include the step 220 of applying suction through a suction tube 130 attached to the continuous dam 110 wherein the suction tube 130 defines a suction channel 140 continuous with the one or more inlet 120.

[0160] The invention also provides a method 300 of manufacturing a suction retractor 100. As shown in FIG. 4A, method 300 includes step 310 of forming a continuous dam 110 defining one or more inlet 120 to thereby manufacture the suction retractor 100. The continuous dam formed may also define continuous channel 121.

[0161] FIG. 4B shows another embodiment of method 300 including the further step 320 of forming or attaching a suction tube 130 defining a suction channel 140 so that the suction channel 140 and one or more inlet 120 are continuous.

[0162] FIG. 5A shows a kit 400 according to one embodiment of the invention which comprises a retractor 100 comprising continuous dam 110 and suction tube 130. Suction tube 130 may be attached to the continuous dam 110 by

joining distal tube port 132 to dam port 117 so that suction channel 140 is continuous with inlet 120 and/or continuous channel 121.

[0163] Another embodiment of a kit 400 according to the invention is shown in FIG. 5B which includes a suction apparatus 160 for applying suction through suction channel 140. Suction tube 130 is connected to apparatus 130 by joining proximal tube port 131 to suction apparatus port 161. Suction may be applied continuously or once a seal is attained, suction may be discontinued or applied only intermittently.

[0164] Suction apparatus 160 may be any conventional electronic suction device suitable for applying suction through a tube such as suction tube 130. In one embodiment suction apparatus 160 is a conventional 'wall suction' device through which variable suction pressure may be applied and adjusted by a lever. In another embodiment suction apparatus 160 may be an electronic suction device which is capable of monitoring and maintaining the degree of suction forces applied according to pre-determined settings. In yet another embodiment suction apparatus 160 may be a syringe which is withdrawn to apply suction and generate a seal using a lock or 3 way tap to maintain the suction forces, although in testing to date, this has been demonstrated to be ineffective in maintaining apposition of tissues.

[0165] Kit 400 may also comprise one or more laparoscopic port 173 (see below) and/or instructions for use.

[0166] So that the invention may be readily understood and put into practical effect, the following non-limiting example is provided.

EXAMPLES

Example 1

LiVAC

Liver Vacuum Retraction

[0167] Although not limited thereto, the method of the invention will be further explained with reference to retraction of the liver to expose the organs beneath it during laparoscopic surgery. Retraction of the liver upwards is required in operations performed on the stomach or gallbladder. The retraction is necessary in order to access these organs. When used with the novel suction retractor 100 of the invention this technique is called LiVAC or Liver Vacuum Retraction.

[0168] Laparoscopic surgery and open surgery require the application of force against the under-surface of the liver to lift it upwards. In laparoscopic surgery a dedicated tract or port is created for the insertion of the retractor and maintenance of the retraction. The retractor 100 and method 200 of the invention provide a means of retraction of the liver using suction between the upper (superior) surface of the liver, and the diaphragm.

[0169] As shown in FIG. 6A dam 110 may be positioned between diaphragm 170 and liver 171 and then suction applied through tube 130 so that the liver 171 and diaphragm 170 are held together in apposition and thereby retracted. The lateral attachments of the left lobe of liver to the diaphragm may be divided to reduce counter forces against the suction retraction.

[0170] In the embodiment shown in FIG. 6A dam 110 is inserted through laparoscopic port 173 which is positioned in surgical incision 172 cut in a patient's abdomen 174. Dam 100 is compacted and inserted through port 173 or through

incision 172, with the tubing then brought back through a channel or connection in port 173. Tube 130 is also partially inserted through port 173.

[0171] Advantageously, suction retractor 100 is not only compatible with Single Incision Laparoscopic Surgery (SILS) techniques, but it greatly simplifies SILS. As shown in FIG. 6A, suction tube 130 is suitably narrow so as to enable it to pass through port 173 while still leaving a majority of the annulus of port 173 vacant to receive other laparoscopic instruments. In this way retractor 100 does not exert competing forces against other laparoscopic instruments also inserted through port 173.

[0172] FIG. 6B shows an embodiment in which suction tube 130 is integral with surgical port 173.

[0173] FIG. 6C shows that the retractor 100 of the invention is also compatible with a modified SILS technique in which in addition to port 173 a hollow needle or trochar 175 is inserted through the patient's abdomen 174. The hollow needle or trochar may be attached to suction tube 130 through proximal port 131.

[0174] In this modified SILS technique a shorter length of suction tubing 130 is required within the abdomen with only the addition of a tiny incision for accommodating the needle or trochar 175.

[0175] Retractor 100 may be used to retract either the left or right lobes of the liver.

Example 2

Acetal Prototype

[0176] Initial testing was conducted using a retractor 100 made of a rigid, acetal ring, similar to the one pictured in FIG. 7A. Testing was performed placing retractor 100 between two halves of a liver. As shown in FIG. 9A, the acetal prototype retractor 100 comprises an inlet 120.

[0177] A spacer 190 comprising a wire mesh disc placed in the middle of the acetal continuous dam 110 aided in separation of the two pieces of liver, therefore maximising the area of liver surface exposed to the vacuum, see spacer 190 shown in FIG. 9B. This proved to be successful.

[0178] The increased force acting on the liver surface by the vacuum meant the hard edges of the acetal ring were causing impressions and tissue damage to the surface of the liver. A chamfer 180 was inserted on the walls 112, 113 to reduce this damage. FIG. 7A shows the acetal prototype retractor 100 and FIG. 7B shows the cross-sectional shape change with addition of chamfer 180. This had very little effect upon the suction results as the retractor 100 still maintained a seal on the liver.

[0179] Testing then began using a spacer 190 comprising one or more low-density foam as a means of separating the liver instead of the wire mesh spacer 190. A variety of foam materials as well as foam shapes were tested. One variation is shown in FIG. 8 in which spacer 190 is a disc shaped foam placed in internal area 150 with a cut out at port 120 and a central orifice. It was concluded that no foams worked as effectively as the wire mesh insert spacer 190 because the liver compressed the material when under vacuum and also was sucked into inlet 120.

[0180] A needle valve (not shown) was attached to the suction apparatus 160 to vary the flow rate and it was found that once initial suction was created, the retractor 100 only

failed once the flow was almost zero. Lowering flow rate before the initial seal is created only lengthened the time taken to create the vacuum.

[0181] The acetal retractor 100 was then machined to feature a channel or an undercut 121 through the middle of the inner face, see FIG. 9A. The section directly in front of inlet 120 was then covered by a guard 191 comprising thin tape (see FIG. 9B). Guard 191 prevented the liver from obstructing inlet 120. The results were also enhanced by having an exposed vacuum void within the undercut channel 121.

[0182] An additional retractor 100 was created to contain ridges 192 of progressive height upon the contact surfaces of dam 110 (not shown). It was hypothesised that a seal could be created on the outermost ridge, then if a part of the seal fails as the liver peels away under the force of gravity, it would seal again on the next ridge. It was concluded that this was not successful as the initial seal was always made upon the innermost edge.

[0183] Adding fenestrations 121a by a variety of means such as taping the edges and inserting brass tubing (not shown) into channel 121 seemed to create a slightly more directional flow of air through the vacuum, the overall effect was however minimal.

[0184] The role of the wire mesh spacer 190 was then investigated further, using substitutes such as sink strainers and fibreglass mesh, see FIGS. 10A and 10B. The effects upon the surface of the liver over time were then observed. It was determined that minor damage to the liver in the form of 'bruise like' markings, and impressions upon surface that quickly fade were not of great concern in the design. More severe damage such as blistering and tearing is to be avoided. It was observed that it was not necessarily the separating surface that caused the damage, but rather the distance the liver is able to move into the voids.

[0185] The effect of a lip 193 on walls 112, 113 was then tested, see FIGS. 11A and 11B. It was found that there is a bias to the contact surface being on the very inner edge of the walls 112, 113 or dam 110, so wide lips 193 do not act as seal faces. The lip 193 in this embodiment was formed of silicone and thereby was pliant and found to be more compliant to a slightly uneven surface, creating a better quality of seal compared to previous testing using hard parts.

[0186] It was also observed that elevating the contact face of dam 110 from the spacer 190 enhanced the vacuum effect as this was exposing the liver surface to a greater area of vacuum.

Example 3

Rapid Prototyping

Prototypes 1, 2, 3 and 4

[0187] The results of four prototypes, 1, 2, 3, 4 shown in FIGS. 12A, 12B, 12C and 12D, respectively, in creating a seal with a liver are discussed below.

[0188] As shown in FIG. 12A prototype 1 is circular and has a spacer 190 comprising a series of radial or concentric spacing ribs 194 separated by radial or concentric grooves 194a. Prototype 1 also comprises a central orifice 116. Prototype 1 additionally features a flexible outer lip 193 and a more rigid turreted inner lip 193a.

[0189] FIG. 12B shows prototype 2 which is circular and has rigid outer walls 112, 113, a spacer 190 comprising a series of parallel spacing ribs 195 with small grooves (not

visible) along their length and inlet **120** which extends slightly on the exterior of dam **110**. The spacing ribs **195** are graduated to allow maximum spacing in the centre.

[0190] FIG. 12C shows prototype **3** which is circular and has a spacer **190** comprising a series of parallel spacing ribs **195** with small grooves (not visible) along their length and inlet **120** which extends slightly on the interior of dam **110**. Prototype **3** also features a flexible outer lip **193** and a more rigid turreted inner lip **193a**.

[0191] FIG. 12D shows prototype **4** which is elliptical and has rigid outer walls **112**, **113**, a series of parallel spacing ribs **195** with small grooves (not visible) along their length and a central transverse spacing rib **196** connecting the parallel spacing ribs **195**. Transverse spacing rib **196** is curvilinear.

[0192] The testing was filmed and video footage stored.

[0193] All prototypes created a seal with the liver, although the inlets for these rapid prototypes projected well into the inner perimeter of the dam, leading to a tendency for tissue (liver) to be sucked into the inlet, thereby impeding suction distribution within the dam. Future prototypes will have the inlets recessed.

[0194] Prototype **1** and **3** retractors **100** both had identical outer wall structures of a thin, flexible outer lip **193**, with more rigid turreted inner lip **193a**. This flexible outer lip **193** followed the contours of the liver, with the more rigid inner turreted lip **193a** providing support to the retractor **100**.

[0195] Studies were performed with tubing **130** comprised of both silicone and polytetrafluoroethylene (PTFE). The silicone tubing **130** appears to be best suited as it is flexible, has minimal impact on the contact surface and seal of model. Additionally, the flow rate of the tubing of 3 mm ID was sufficient, and could possibly be decreased if possible.

[0196] The PTFE tubing **130** was not as effective as the rigidity limited the placement options, and impacted the quality of the seal as it transferred forces onto the suction ring.

[0197] Suction tubing is introduced so as to achieve suction forces within the inner confines of the dam. It has been observed that bodily tissues (for example, liver or diaphragm) tend to be drawn into the point of maximum suction forces, at the suction inlet **120**. If this happens, then suction is lost within the remainder of the confines of the dam, resulting in loss of apposition. A variety of strategies can be employed to prevent this from happening, with the view to evening out the suction forces within the confines of the dam. Such strategies include a deep gutter **122** on the inner perimeter of the dam, and structures within this inner perimeter such as one or more rib **125**, **126** which may be fenestrated in continuity with the suction applied; a membrane **114** which may comprise multiple perforations **115** in continuity with the suction applied; one or more spacer **190** which may comprise one or more radial ribs **194**, parallel ribs **195** and/or transverse ribs **195**; and/or a guard **191**.

[0198] The challenge in upper gastro-intestinal SILS is exposure of the organs under the liver without resorting to additional ports. The retractor **100** and method **200** of the invention provide a simpler means of retracting the liver upwards. In this way, although not limited thereto the present retractor **100** and method **200** greatly simplifies upper Gastrointestinal (GI) surgery whether using true SILS or conventional multi-port laparoscopic surgery.

[0199] As well as the advantages of the invention elucidated above, it is clear that retractor **100**, method **200** and method **300** greatly simplify complicated surgical techniques and offer a rapidity of use not previously provided.

[0200] As elucidated above, a variety of sizes and shapes of the dam may be utilised. Although not restricted thereto prototype testing has shown that a dam **110** comprising a ring is most stable.

[0201] Advantageously, retractor **100** may be used as a stand-alone device, or incorporated into a range of existing single-incision laparoscopic ports. Retractor **100** is conceived as being able to be introduced directly into the peritoneal cavity through the surgical incision, or conversely, in a collapsible form through a laparoscopic port. In the latter embodiment, the dam would expand to its desired shape by memory or potentially inflatable structures. The device could be supplied for use through standard operating theatre suction devices, or through a stand-alone suction device designed to monitor and maintain suction within pre-determined settings.

[0202] Throughout the specification the aim has been to describe the preferred embodiments of the invention without limiting the invention to any one embodiment or specific collection of features. It will therefore be appreciated by those of skill in the art that, in light of the instant disclosure, various modifications and changes can be made in the particular embodiments exemplified without departing from the scope of the present invention.

[0203] All computer programs, algorithms, industrial, patent and scientific literature referred to herein is incorporated herein by reference.

1. A suction retractor comprising:
 - a flexible continuous dam which forms a closed loop of any shape and which defines one or more inlet, the one or more inlet opening into an interior of the closed loop and comprising an opening or orifice into an interior area surrounded and defined by the closed loop, so that suction can be applied through the one or more inlet and into the interior of the continuous dam.
 2. The suction retractor of claim 1 further comprising a suction tube defining a suction channel, the suction tube attached to or attachable to the continuous dam and when attached the suction channel continuous with the one or more inlet.
 3. The suction retractor of claim 1 wherein the one or more inlet opens to a continuous channel extending throughout an interior of the closed loop.
 4. The suction retractor of claim 1 wherein the continuous channel comprises an open channel.
 5. The suction retractor of claim 1 wherein the continuous channel comprises a plurality of fenestrations.
 6. (canceled)
 7. The suction retractor of claim 1 wherein the continuous dam is planar or substantially planar.
 8. The suction retractor of claim 1 wherein the flexible continuous dam comprises a first compacted configuration for insertion and a second open configuration for retraction.
 - 9.-11. (canceled)
 12. A method of retracting one or more body part, tissue, organ or part thereof using the suction retractor of claim 1.
 13. A method of retracting one or more body part, tissue, organ or part thereof including:
 - applying suction through a retractor, the retractor comprising one or more inlet defined in a flexible continuous dam, the continuous dam forming a closed loop of any shape and the one or more inlet opening into an interior of the closed loop and comprising an opening or orifice into an interior area surrounded and defined by the closed loop, to thereby form a seal to the one or more

body part, tissue, organ or part thereof and retract the one or more body part, tissue, organ or part thereof.

14. The method of claim **13** further including the step of applying suction through a suction tube attached to the continuous dam wherein the suction tube defines a suction channel continuous with the one or more inlet.

15. The method of claim **13** wherein the one or more inlet opens to a continuous channel extending throughout an interior of the closed loop.

16. The method of claim **15** wherein the continuous channel comprises an open channel.

17. The method of claim **15** wherein the continuous channel comprises a plurality of fenestrations.

18. The method of claim **14** wherein when the suction tube is attached to the continuous dam, the suction tube is disposed laterally on the continuous dam.

19. The method of claim **13** wherein the continuous dam is planar or substantially planar.

20. The method of claim **13** wherein the flexible continuous dam comprises a first compacted configuration for insertion and a second open configuration for retraction.

21. A method of manufacturing a suction retractor including:

forming a flexible continuous dam which forms a closed loop of any shape and which defines one or more inlet

opening into an interior of the closed loop and comprising an opening or orifice into an interior area surrounded and defined by the closed loop to thereby manufacture the suction retractor.

22. The method of claim **21** further including forming or attaching a suction tube defining a suction channel so that the suction channel and one or more inlet are continuous.

23.-28. (canceled)

29. A system for retracting a body part, tissue, organ and/or part thereof comprising:

a flexible continuous dam forming a closed loop of any shape and defining one or more inlet through which suction can be applied, the one or more inlet opening into an interior of the closed loop and comprising an opening or orifice into an interior area surrounded and defined by the closed loop; and

a suction tube defining a suction channel, the suction tube attached to or attachable to the continuous dam wherein when attached the suction channel is continuous with the one or more inlet.

30. The system of claim **29** further comprising an apparatus for applying suction through the suction tube and the one or more inlet.

31.-32. (canceled)

* * * * *

专利名称(译)	吸气牵开器		
公开(公告)号	US20130109924A1	公开(公告)日	2013-05-02
申请号	US13/697470	申请日	2011-05-13
[标]申请(专利权)人(译)	甘菲利		
申请(专利权)人(译)	甘, PHILIP		
当前申请(专利权)人(译)	LIVAC PTY LTD		
[标]发明人	GAN PHILIP		
发明人	GAN, PHILIP		
IPC分类号	A61B17/02		
CPC分类号	A61B17/0218 A61B17/02 A61B2017/308 A61B2017/306		
优先权	2010902064 2010-05-13 AU		
其他公开文献	US8814788		
外部链接	Espacenet USPTO		

摘要(译)

本发明提供了一种抽吸牵开器，其包括柔性连续挡板，该挡板形成任何形状的闭合环，并且限定一个或多个进入闭合环内部的入口，从而可以将抽吸施加到连续坝的内部。抽吸牵开器还可包括限定抽吸通道的抽吸管，抽吸管连接到或连接到连续坝，并且当连接抽吸通道时，抽吸通道与一个或多个入口连续。一个或多个入口可以通向延伸遍及闭环内部的连续通道。优选地，连续坝是平面的或基本上平面的，并且包括用于插入的第一压实构造和用于缩回的第二打开构造。本发明的抽吸牵开器可应用于单切口和常规腹腔镜手术。

