



US 20050263562A1

(19) **United States**

(12) **Patent Application Publication**

Shelton, IV et al.

(10) **Pub. No.: US 2005/0263562 A1**

(43) **Pub. Date: Dec. 1, 2005**

(54) **ARTICULATING SURGICAL STAPLING INSTRUMENT INCORPORATING A TWO-PIECE E-BEAM FIRING MECHANISM**

(60) Provisional application No. 60/591,694, filed on Jul. 28, 2004.

Publication Classification

(76) Inventors: **Frederick E. Shelton IV**, Hillsboro, OH (US); **Kevin Ross Doll**, Mason, OH (US); **Jerry R. Morgan**, Cincinnati, OH (US); **Michael Earl Setser**, Burlington, KY (US)

(51) **Int. Cl.⁷** **A61B 17/04**
(52) **U.S. Cl.** **227/176.1; 227/19**

(57) **ABSTRACT**

A surgical severing and stapling instrument, suitable for laparoscopic and endoscopic clinical procedures, clamps tissue within an end effector of an elongate channel pivotally opposed by an anvil. An E-beam firing bar moves distally through the clamped end effector to sever tissue and to drive staples on each side of the cut. The E-beam firing bar affirmatively spaces the anvil from the elongate channel to assure properly formed closed staples, especially when an amount of tissue is clamped that is inadequate to space the end effector. In particular, an upper pin of the firing bar longitudinally moves through an anvil slot and a channel slot is captured between a lower cap and a middle pin of the firing bar to assure a minimum spacing. Forming the E-beam from a thickened distal portion and a thinned proximal strip enhances manufacturability and facilitates use in such articulating surgical instruments.

Correspondence Address:

Frost Brown Todd LLC
2200 PNC Center
201 East Fifth Street
Cincinnati, OH 45202 (US)

(21) Appl. No.: **10/955,042**

(22) Filed: **Sep. 30, 2004**

Related U.S. Application Data

(63) Continuation-in-part of application No. 10/443,617, filed on May 20, 2003.

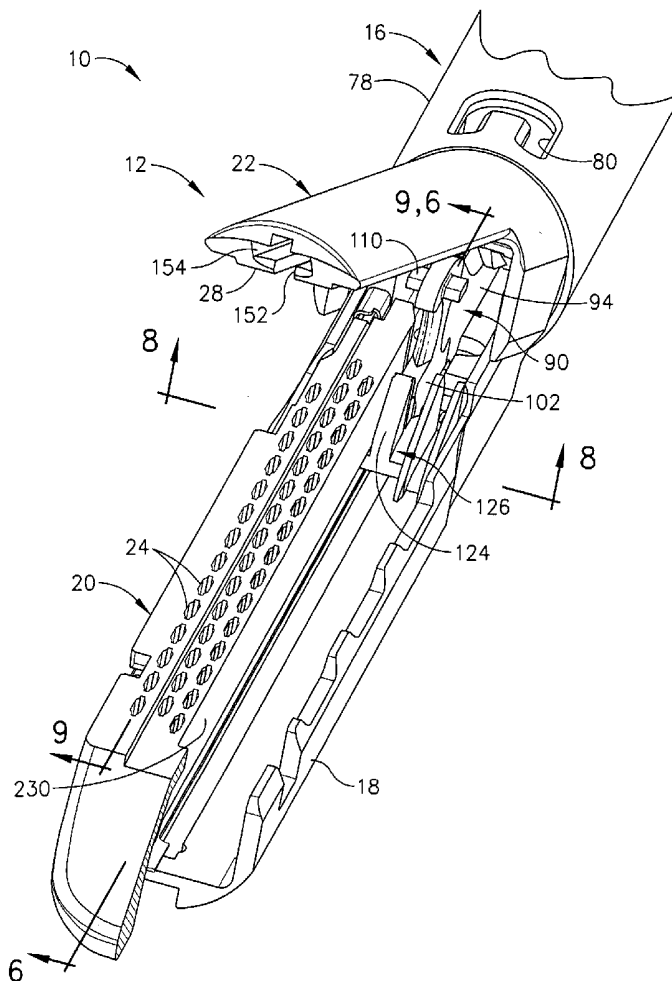

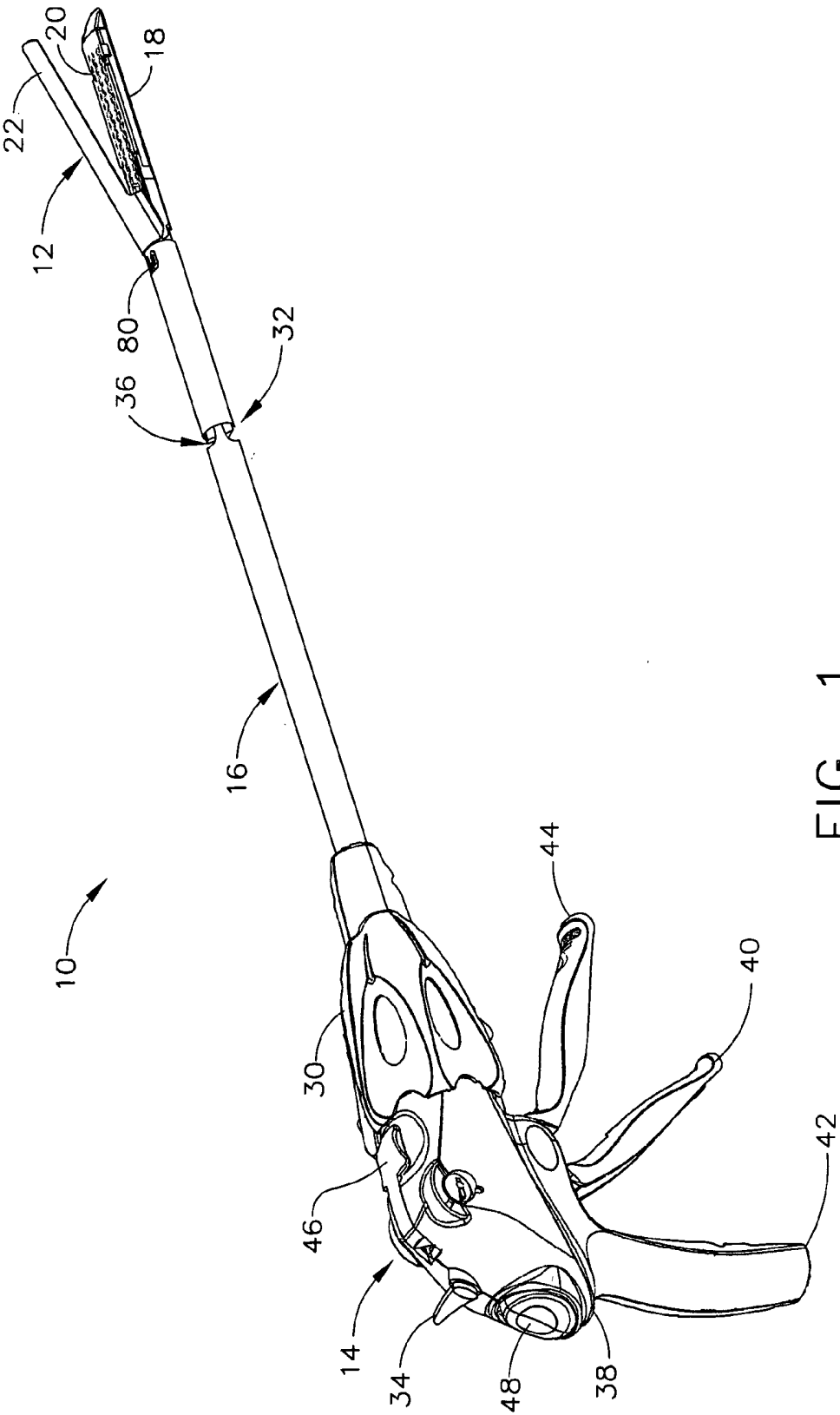

FIG. 1

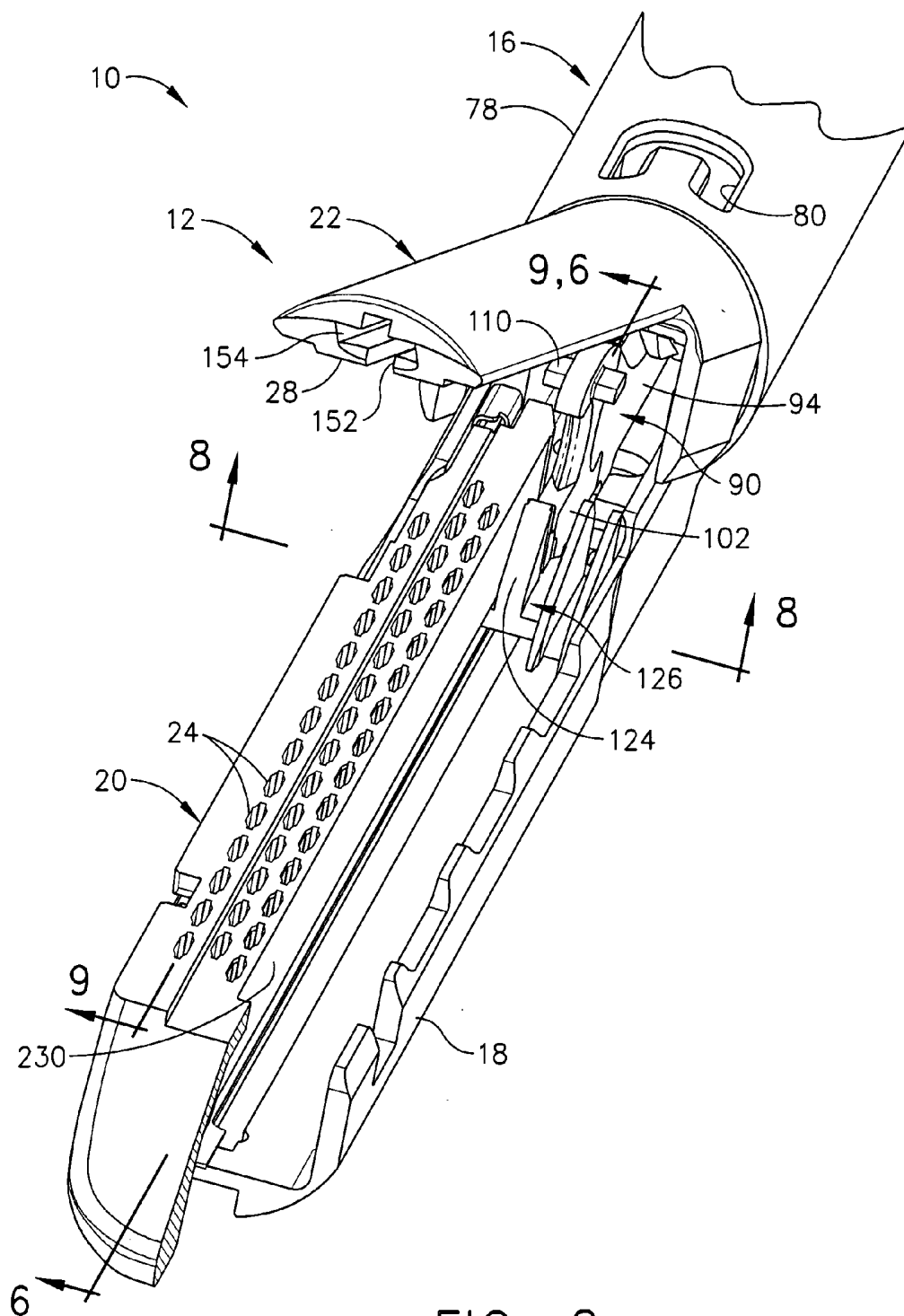

FIG. 2

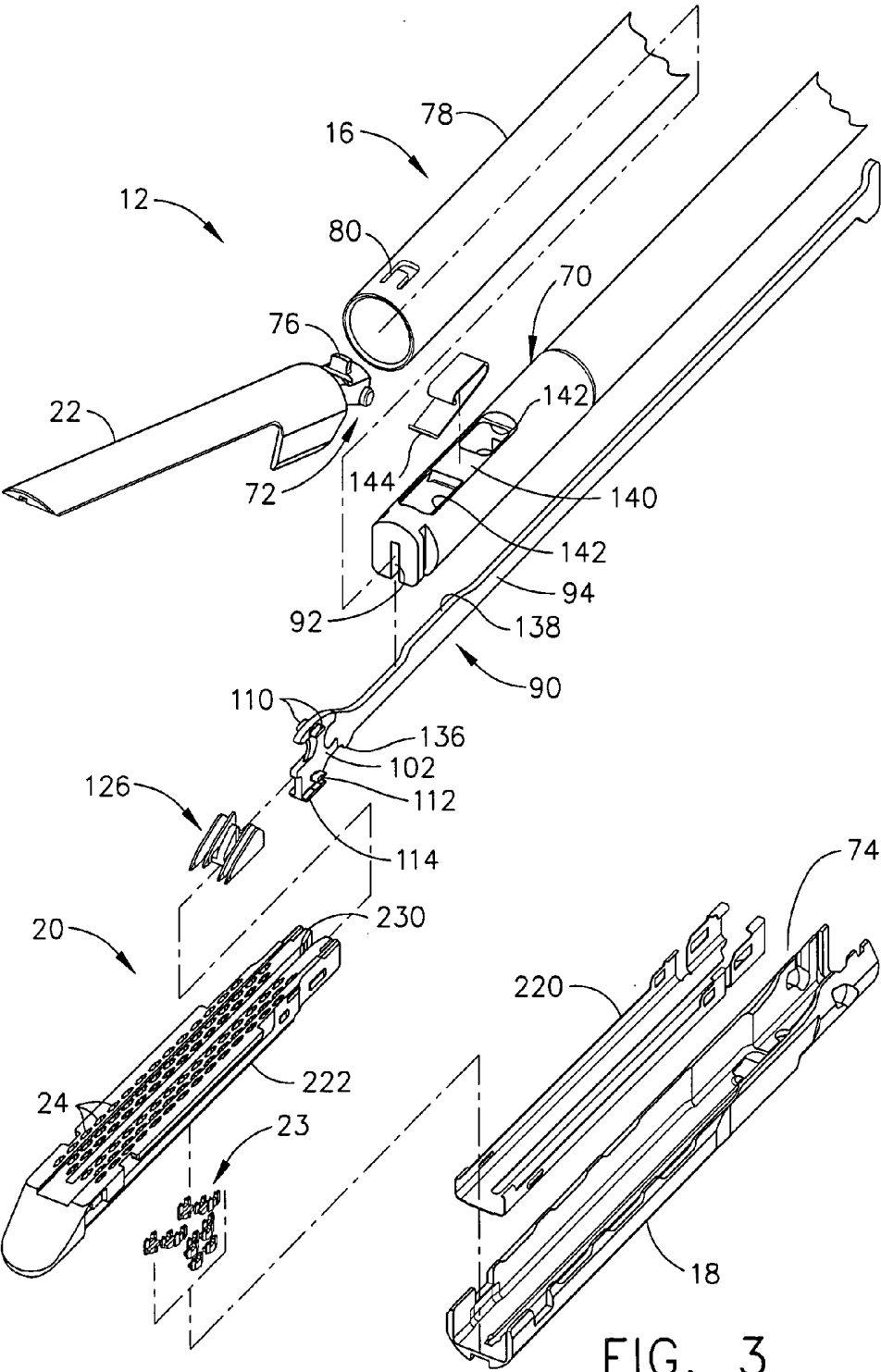

FIG. 3

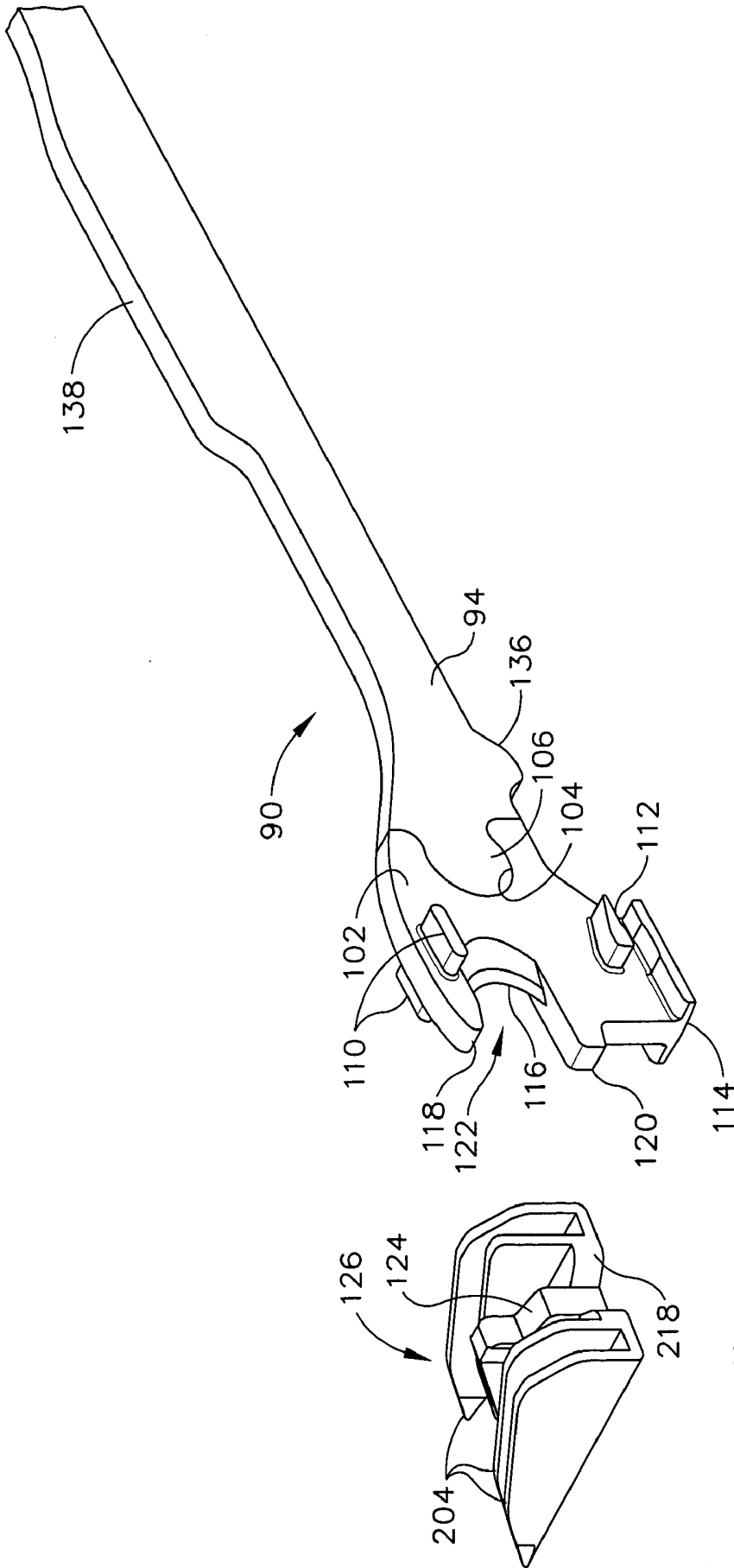

FIG. 4

FIG. 5

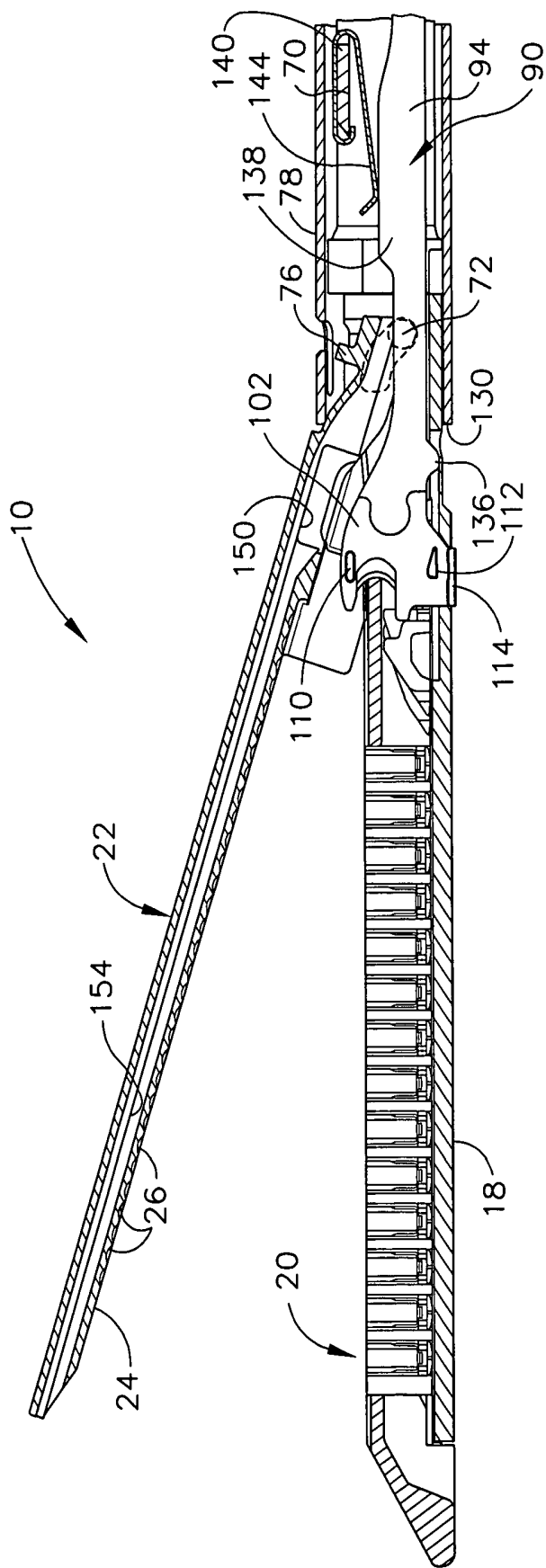

FIG. 6

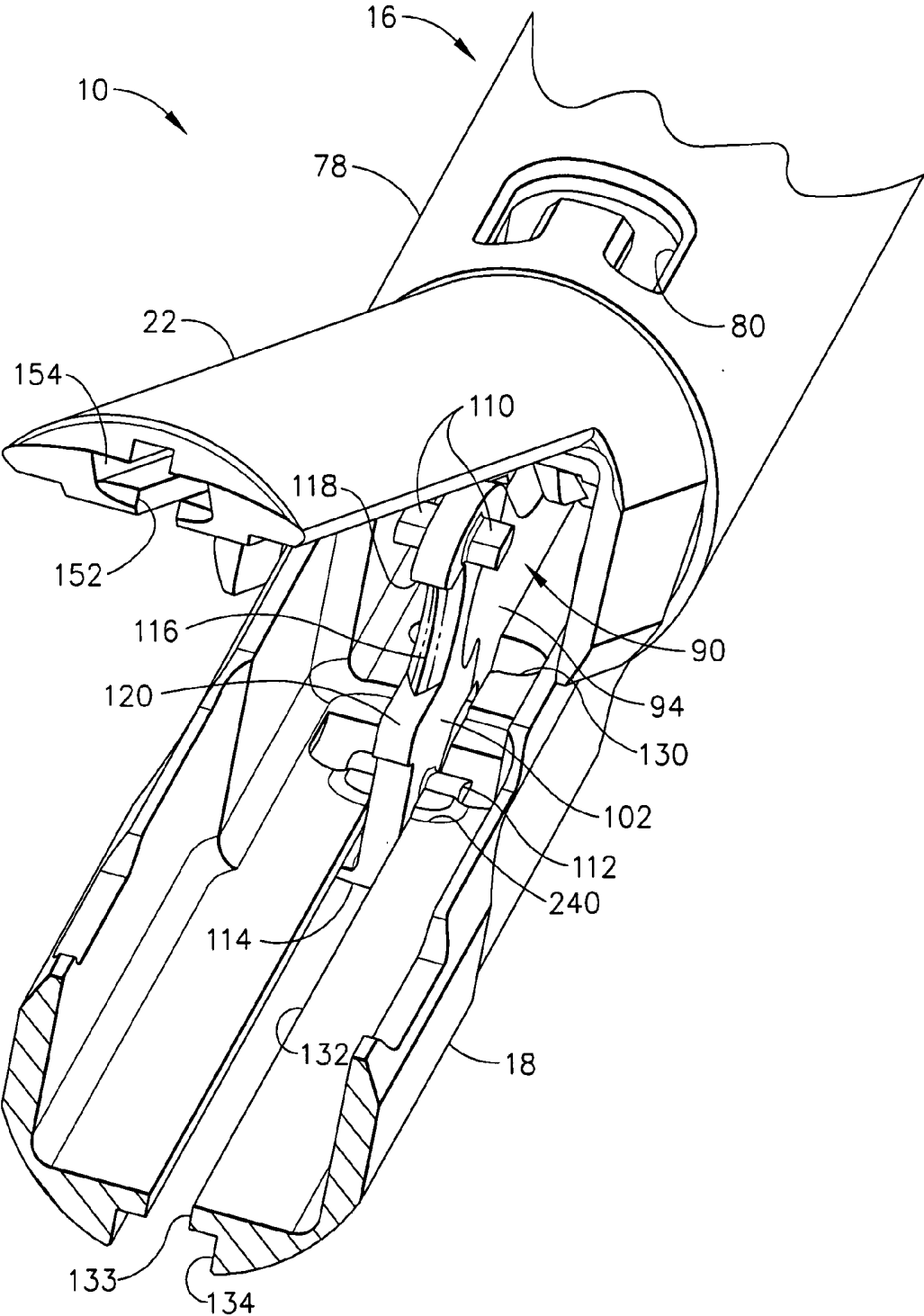

FIG. 7

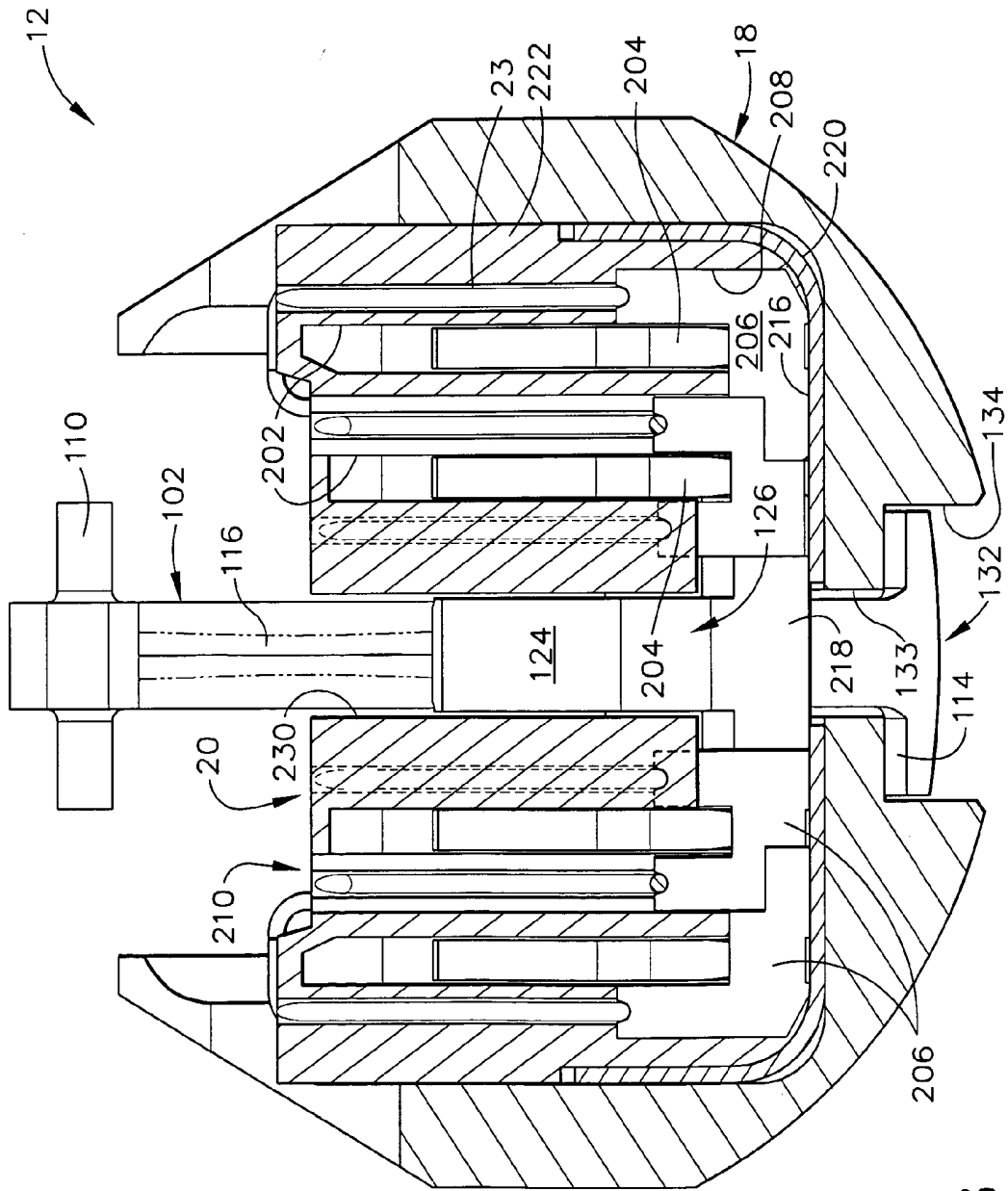

FIG. 8

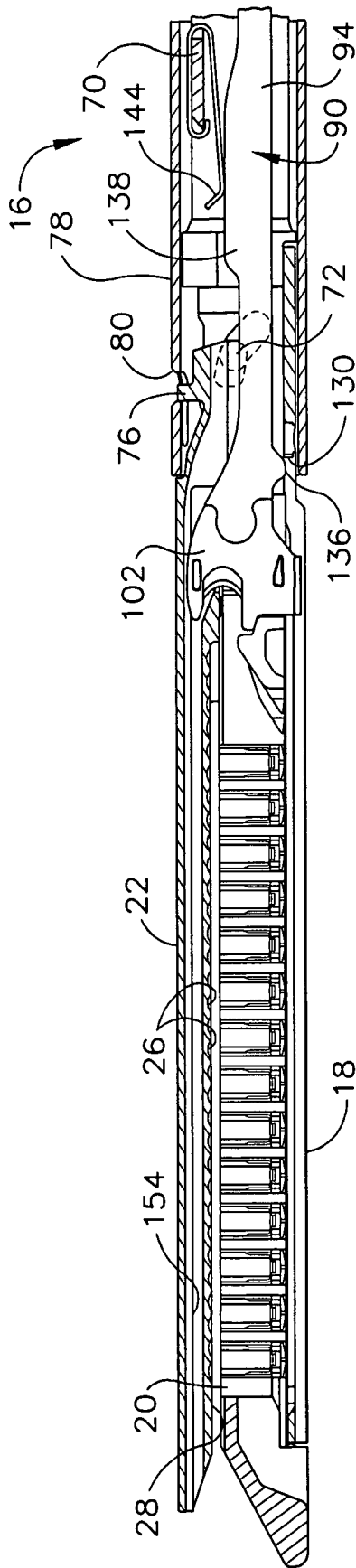

FIG. 9

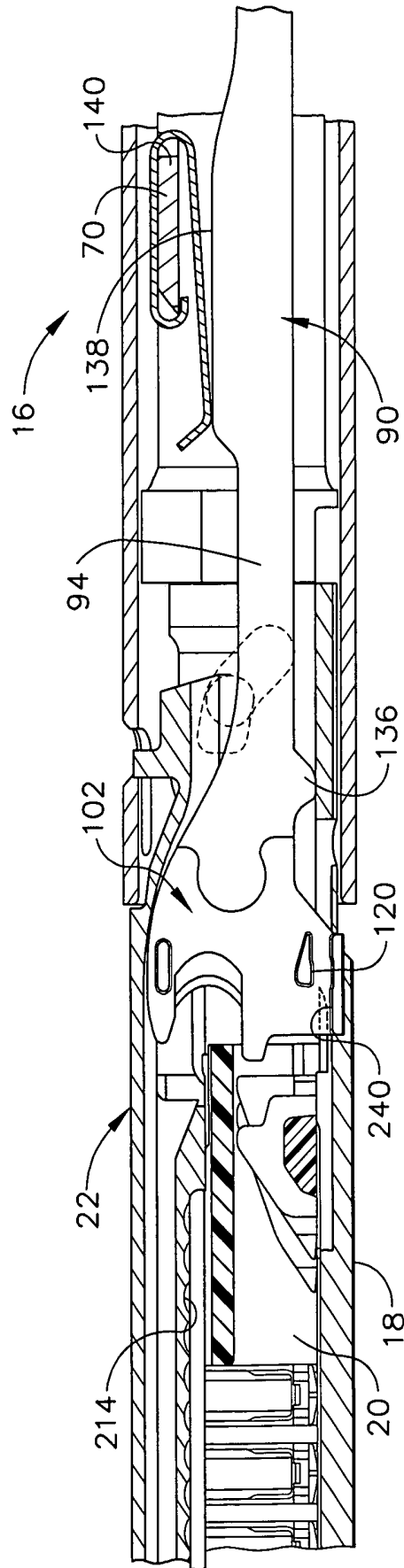

FIG. 10

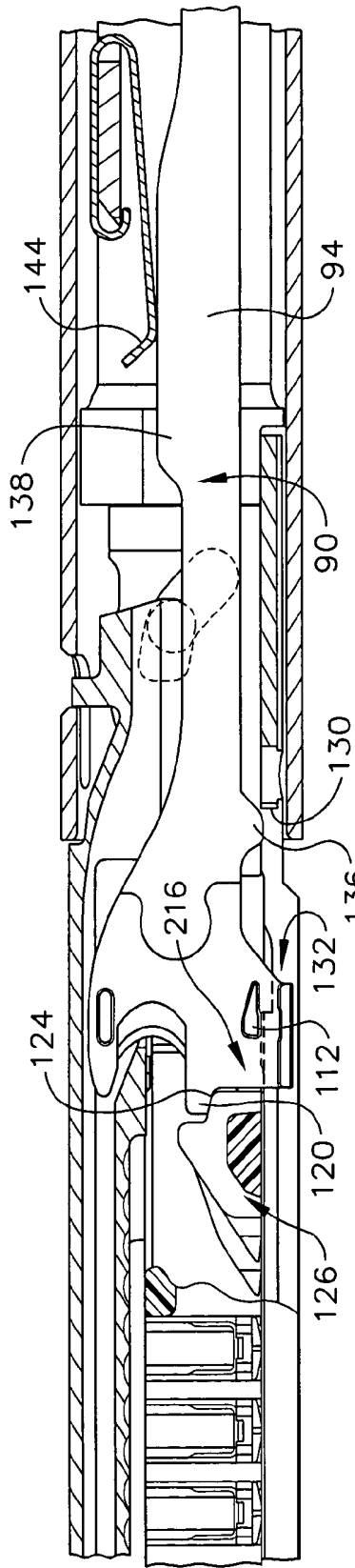

FIG. 11

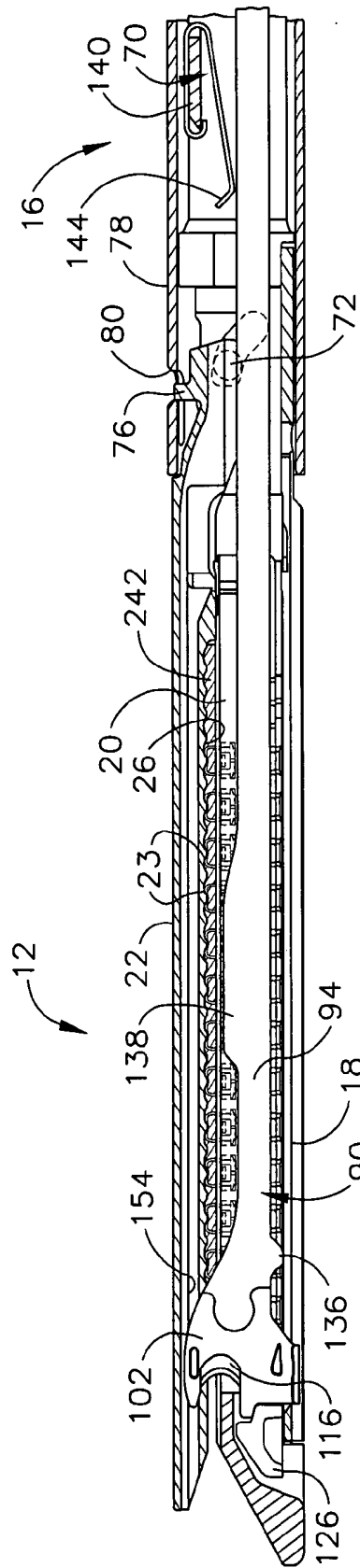

FIG. 12

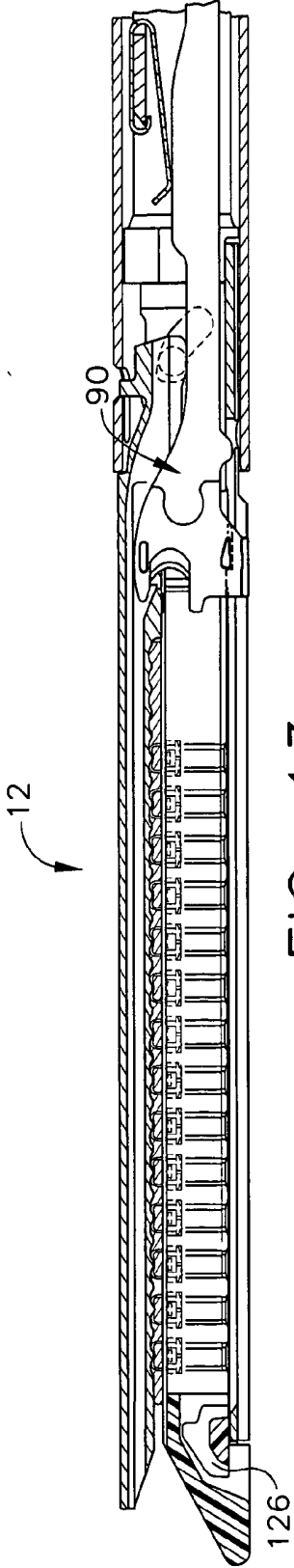

FIG. 13

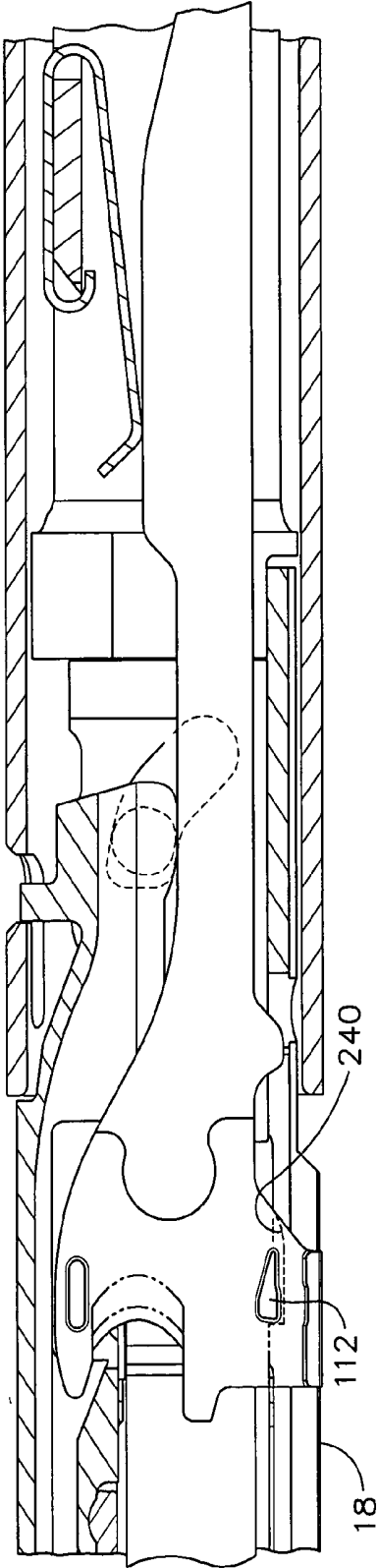

FIG. 14

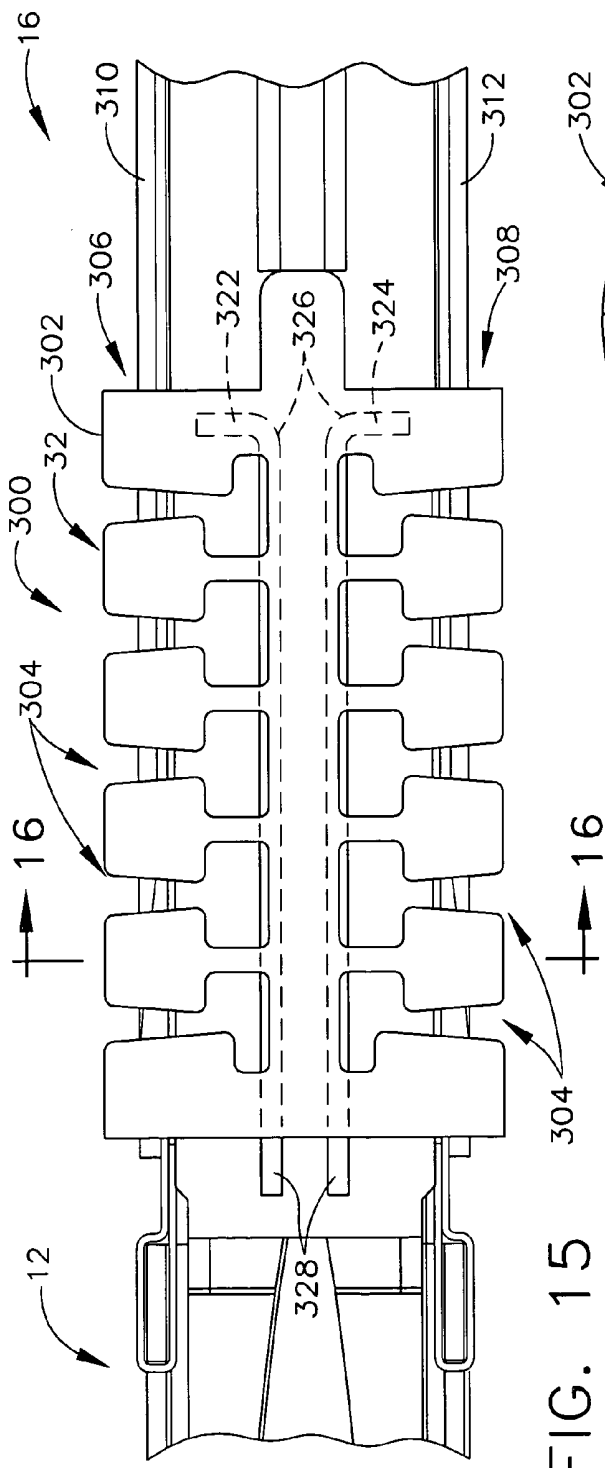

FIG. 15

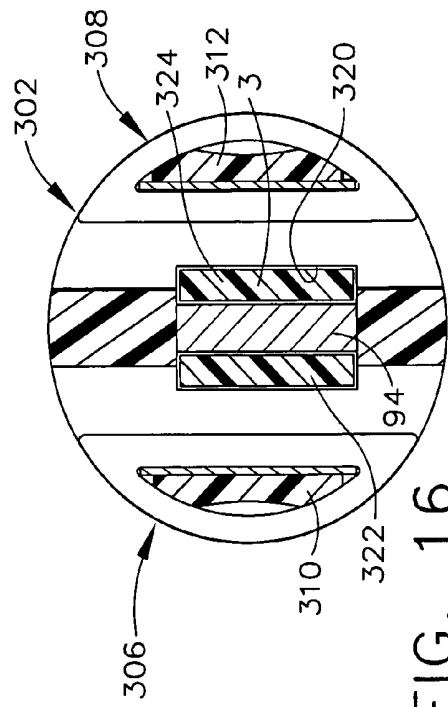

FIG. 16

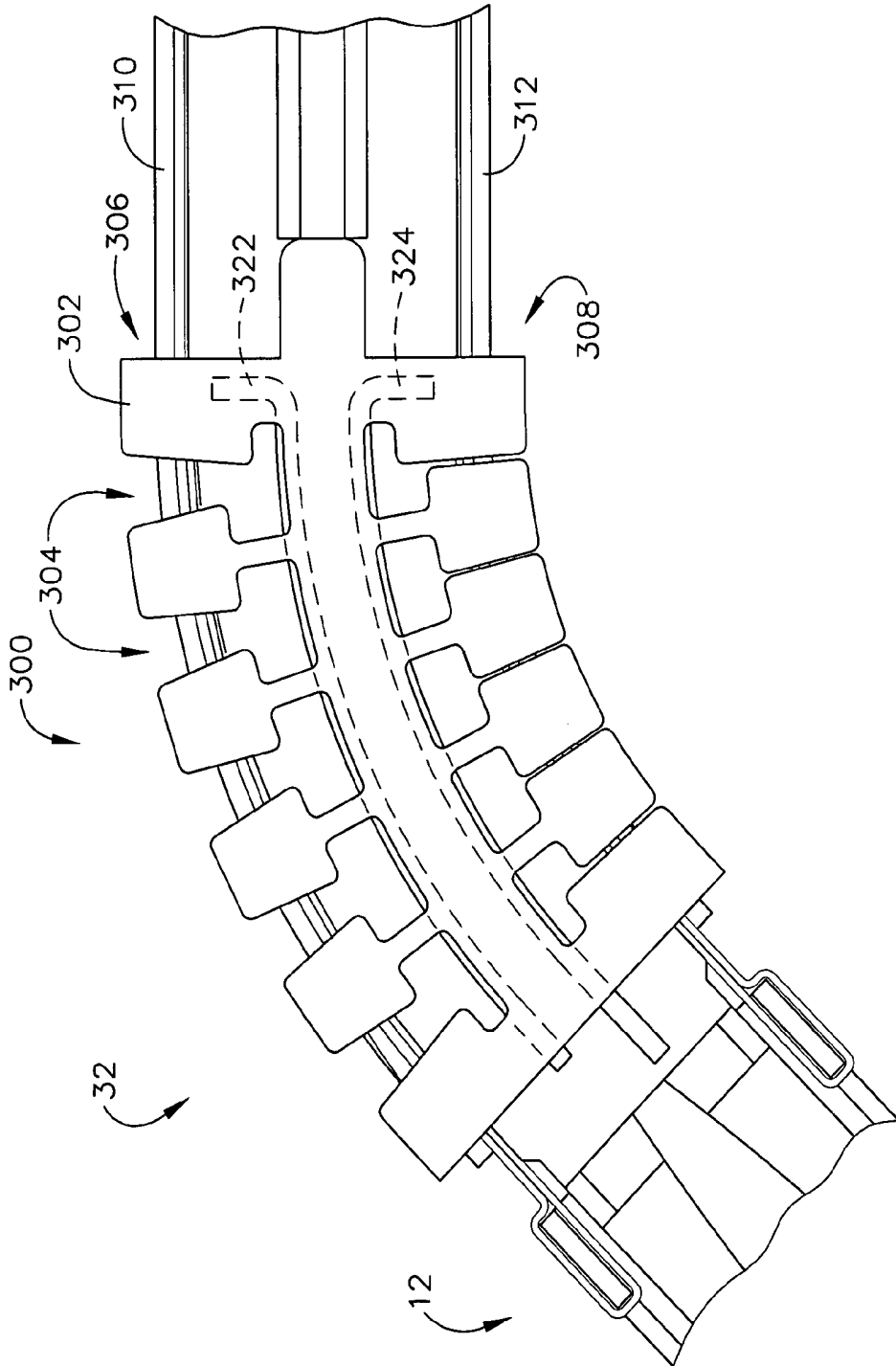

FIG. 17

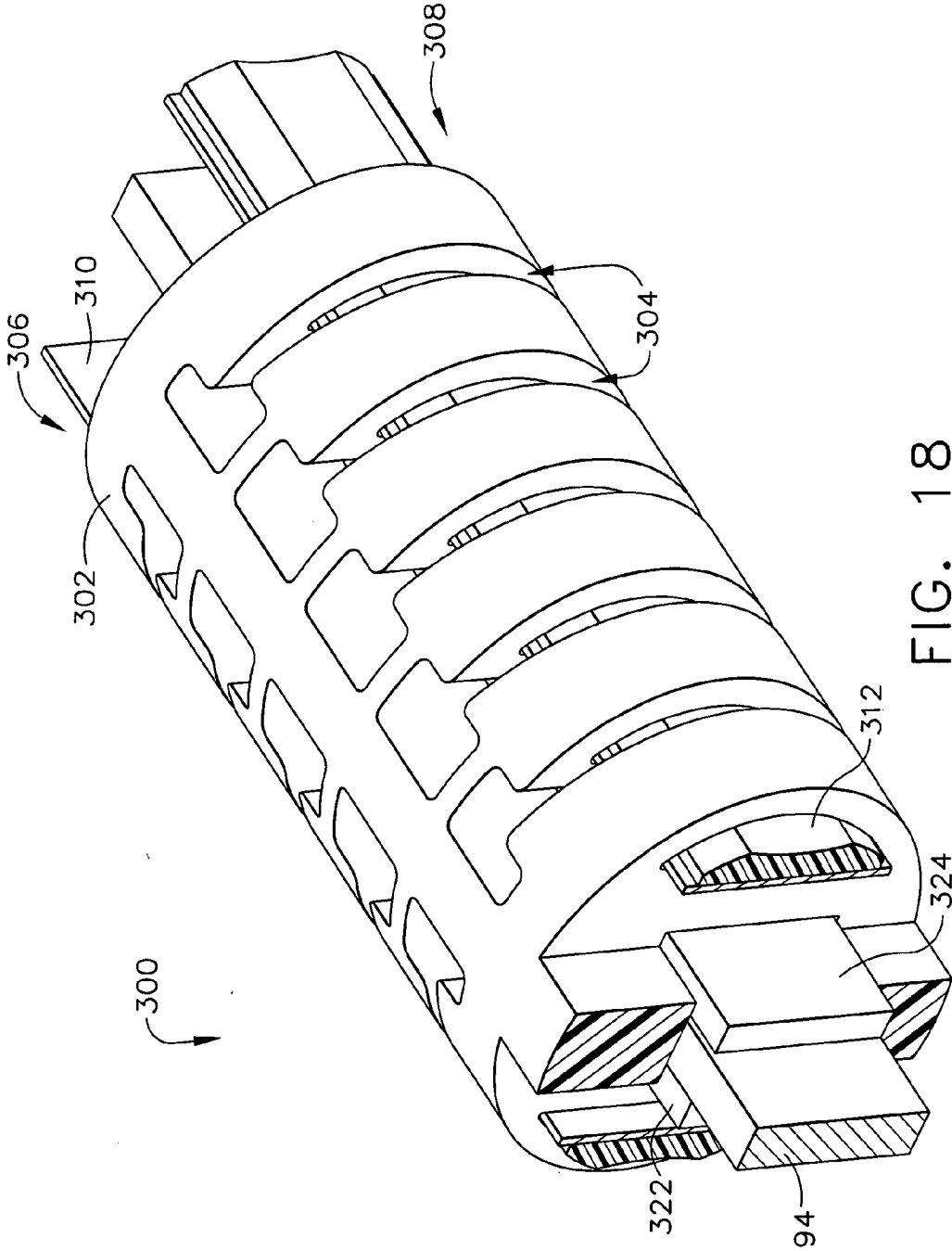

FIG. 18

**ARTICULATING SURGICAL STAPLING
INSTRUMENT INCORPORATING A TWO-PIECE
E-BEAM FIRING MECHANISM**

FIELD OF THE INVENTION

[0001] The present application hereby claims the benefit of the U.S. provisional patent application entitled "SURGICAL INSTRUMENT INCORPORATING AN ELECTRICALLY ACTUATED ARTICULATION MECHANISM", to Shelton, Ser. No. 60/591,694, filed on 28 Jul. 2004. The present application is a continuation-in-part patent application of the U.S. nonprovisional patent application entitled "SURGICAL STAPLING INSTRUMENT INCORPORATING AN E-BEAM FIRING MECHANISM" to Shelton et al., Ser. No. 10/443,617, filed on 20 May 2003, the disclosure of which is hereby incorporated by reference in its entirety.

FIELD OF THE INVENTION

[0002] The present invention relates in general to surgical instruments that are suitable for endoscopically inserting an end effector that is actuated by a longitudinally driven firing member, and more particularly a surgical stapling and severing instrument that has an articulating shaft.

BACKGROUND OF THE INVENTION

[0003] Endoscopic surgical instruments are often preferred over traditional open surgical devices since a smaller incision tends to reduce the post-operative recovery time and complications. Consequently, significant development has gone into a range of endoscopic surgical instruments that are suitable for precise placement of a distal end effector at a desired surgical site through a cannula of a trocar. These distal end effectors engage the tissue in a number of ways to achieve a diagnostic or therapeutic effect (e.g., endocutter, grasper, cutter, staplers, clip applicator, access device, drug/gene therapy delivery device, and energy device using ultrasound, RF, laser, etc.).

[0004] Positioning the end effector is constrained by the trocar. Generally these endoscopic surgical instruments include a long shaft between the end effector and a handle portion manipulated by the clinician. This long shaft enables insertion to a desired depth and rotation about the longitudinal axis of the shaft, thereby positioning the end effector to a degree. With judicious placement of the trocar and use of graspers, for instance, through another trocar, often this amount of positioning is sufficient. Surgical stapling and severing instruments, such as described in U.S. Pat. No. 5,465,895, are an example of an endoscopic surgical instrument that successfully positions an end effector by insertion and rotation.

[0005] More recently, U.S. patent Ser. No. 10/443,617, "SURGICAL STAPLING INSTRUMENT INCORPORATING AN E-BEAM FIRING MECHANISM" to Shelton et al., filed on 20 May 2003, which has been incorporated by reference in its entirety, describes an improved "E-beam" firing bar for severing tissue and actuating staples. Some of the additional advantages include affirmatively spacing the jaws of the end effector, or more specifically a staple applying assembly, even if slightly too much or too little tissue is clamped for optimal staple formation. Moreover,

the E-beam firing bar engages the end effector and staple cartridge in a way that enables several beneficial lockouts to be incorporated.

[0006] Depending upon the nature of the operation, it may be desirable to further adjust the positioning of the end effector of an endoscopic surgical instrument. In particular, it is often desirable to orient the end effector at an axis transverse to the longitudinal axis of the shaft of the instrument. The transverse movement of the end effector relative to the instrument shaft is conventionally referred to as "articulation". This is typically accomplished by a pivot (or articulation) joint being placed in the extended shaft just proximal to the staple applying assembly. This allows the surgeon to articulate the staple applying assembly remotely to either side for better surgical placement of the staple lines and easier tissue manipulation and orientation. This articulated positioning permits the clinician to more easily engage tissue in some instances, such as behind an organ. In addition, articulated positioning advantageously allows an endoscope to be positioned behind the end effector without being blocked by the instrument shaft.

[0007] Approaches to articulating a surgical stapling and severing instrument tend to be complicated by integrating control of the articulation along with the control of closing the end effector to clamp tissue and fire the end effector (i.e., stapling and severing) within the small diameter constraints of an endoscopic instrument. Generally, the three control motions are all transferred through the shaft as longitudinal translations. For instance, U.S. Pat. No. 5,673,840 discloses an accordion-like articulation mechanism ("flex-neck") that is articulated by selectively drawing back one of two connecting rods through the implement shaft, each rod offset respectively on opposite sides of the shaft centerline. The connecting rods ratchet through a series of discrete positions.

[0008] Another example of longitudinal control of an articulation mechanism is U.S. Pat. No. 5,865,361 that includes an articulation link offset from a camming pivot such that pushing or pulling longitudinal translation of the articulation link effects articulation to a respective side. Similarly, U.S. Pat. No. 5,797,537 discloses a similar rod passing through the shaft to effect articulation.

[0009] In co-pending and commonly owned U.S. patent application Ser. No. 10/615,973, "SURGICAL INSTRUMENT INCORPORATING AN ARTICULATION MECHANISM HAVING ROTATION ABOUT THE LONGITUDINAL AXIS", to Frederick E. Shelton IV et al, the disclosure of which is hereby incorporated by reference in its entirety, a rotational motion is used to transfer articulation motion as an alternative to a longitudinal motion.

[0010] In the application entitled "SURGICAL STAPLING INSTRUMENT INCORPORATING AN E-BEAM FIRING MECHANISM" to Shelton et al., Ser. No. 10/443,617, filed on 20 May 2003, the disclosure of which was previously incorporated by reference in its entirety, a surgical severing and stapling instrument, suitable for laparoscopic and endoscopic clinical procedures, clamps tissue within an end effector of an elongate channel pivotally opposed by an anvil. An E-beam firing bar moves distally through the clamped end effector to sever tissue and to drive staples on each side of the cut. The E-beam firing bar affirmatively spaces the anvil from the elongate channel to

assure properly formed closed staples, especially when an amount of tissue is clamped that is inadequate to space the end effector. In particular, an upper pin of the firing bar longitudinally moves through an anvil slot and a channel slot is captured between a lower cap and a middle pin of the firing bar to assure a minimum spacing. While this E-beam firing bar has a number of advantages, additional features are desirable to enhance manufacturability and to minimize dimensional variations.

[0011] Consequently, a significant need exists for a surgical instrument with a firing bar that advantageously assures proper spacing between clamped jaws of an end effector and which facilitates articulation of its shaft.

BRIEF SUMMARY OF THE INVENTION

[0012] The invention overcomes the above-noted and other deficiencies of the prior art by providing a firing mechanism that affirmatively vertically spaces an end effector of a surgical stapling and severing instrument. Thus, the instrument structurally assures adequate spacing to achieve proper stapling, even in instances where too little tissue is clamped in the end effector. Integrally forming these features into an E-beam that includes a cutting edge realizes consistent spacing and performance as the E-beam fires through an end effector such as a severing and stapling assembly. Further, proximally attaching a separate, thinned firing bar to the E-beam enhances use in articulating surgical instruments wherein reduced cross sectional area and the ability to flex in a plane of articulation are desirable.

[0013] In one aspect of the invention, a surgical instrument includes a handle portion operable to produce a firing motion that actuates an implement portion. This implement portion has an elongate channel that receives a staple cartridge opposed by a pivotally attached anvil. A firing device includes a distally presented cutting edge longitudinally received between the elongate channel and the anvil, an upper member engageable to the anvil channel, a lower member engaging the channel slot, and a middle member operable to actuate the wedge sled, which is integral to the staple cartridge. The middle member advantageously opposes pinching of the end effector, assuring proper staple formation even when an otherwise too small amount of tissue has been clamped. These spacing and cutting features are advantageously formed into an E-beam while flexibility for articulation is provided by a thinned firing bar attached to the E-beam.

[0014] These and other objects and advantages of the present invention shall be made apparent from the accompanying drawings and the description thereof.

DESCRIPTION OF THE FIGURES

[0015] The accompanying drawings, which are incorporated in and constitute a part of this specification, illustrate embodiments of the invention, and, together with the general description of the invention given above, and the detailed description of the embodiments given below, serve to explain the principles of the present invention.

[0016] FIG. 1 is a perspective view of an endoscopic surgical stapling instrument for surgical stapling and severing in an open, unarticulated state.

[0017] FIG. 2 is a left, front perspective view of an open staple applying assembly of the surgical stapling instrument

of FIG. 1 with a right half portion of a replaceable staple cartridge included in a staple channel.

[0018] FIG. 3 is an exploded perspective view of the staple applying assembly of FIG. 2 with a complete replaceable staple cartridge and an alternative nonarticulating shaft configuration.

[0019] FIG. 4 is a perspective view of a two-piece knife and firing bar ("E-beam") of the staple applying assembly of FIG. 2.

[0020] FIG. 5 is a perspective view of a wedge sled of a staple cartridge of the staple applying assembly of FIG. 1.

[0021] FIG. 6 is a left side view in elevation taken in longitudinal cross section along a centerline line 6-6 of the staple applying assembly of FIG. 2.

[0022] FIG. 7 is a perspective view of the open staple applying assembly of FIG. 2 without the replaceable staple cartridge, a portion of the staple channel proximate to a middle pin of two-piece knife and firing bar, and without a distal portion of a staple channel.

[0023] FIG. 8 is a front view in elevation taken in cross section along line 8-8 of the staple applying assembly of FIG. 2 depicting internal staple drivers of the staple cartridge and portions of the two-piece knife and firing bar.

[0024] FIG. 9 is a left side view in elevation taken generally along the longitudinal axis of line 6-6 of a closed staple applying assembly of FIG. 2 to include center contact points between the two-piece knife and wedge sled but also laterally offset to show staples and staple drivers within the staple cartridge.

[0025] FIG. 10 is a left side detail view in elevation of the staple applying assembly of FIG. 9 with the two-piece knife retracted slightly more as typical for staple cartridge replacement.

[0026] FIG. 11 is a left side detail view in elevation of the staple applying assembly of FIG. 10 with the two-piece knife beginning to fire, corresponding to the configuration depicted in FIG. 9.

[0027] FIG. 12 is a left side cross-sectional view in elevation of the closed staple applying assembly of FIG. 9 after the two-piece knife and firing bar has distally fired.

[0028] FIG. 13 is a left side cross-sectional view in elevation of the closed staple applying assembly of FIG. 12 after firing of the staple cartridge and retraction of the two-piece knife.

[0029] FIG. 14 is a left side cross-sectional detail view in elevation of the staple applying assembly of FIG. 13 with the two-piece knife allowed to drop into a lockout position.

[0030] FIG. 15 is a top view in section taken along lines 15-15 of an articulation joint (flex neck) of the surgical stapling instrument of FIG. 1.

[0031] FIG. 16 is a front view in elevation taken in vertical cross section along lines 16-16 of the articulation joint of FIG. 15, showing electroactive polymer (EAP) plate articulation actuators and EAP support plates for a firing bar.

[0032] FIG. 17 is a top view in section along lines 15-15 of the articulation joint of FIG. 16 after articulation.

[0033] FIG. 18 is a perspective view of the articulation joint of FIG. 15.

DETAILED DESCRIPTION OF THE INVENTION

[0034] In FIGS. 1-3, a surgical stapling instrument 10 has at its distal end an end effector, depicted as a staple applying assembly 12, spaced apart from a handle 14 (FIG. 2) by an elongate shaft 16. The staple applying assembly 12 includes a staple channel 18 for receiving a replaceable staple cartridge 20. Pivotaly attached to the staple channel 18 is an anvil 22 that clamps tissue to the staple cartridge 20 and serves to deform staples 23 (FIG. 3) driven up from staple holes 24 in the staple cartridge 20 against staple forming recesses 26 (FIG. 6) in an anvil undersurface 28 into a closed shape. When the staple applying assembly 12 is closed, its cross sectional area, as well as the elongate shaft 16 are suitable for insertion through a small surgical opening, such as through a cannula of a trocar (not shown).

[0035] With particular reference to FIG. 1, correct placement and orientation of the staple applying assembly 12 is facilitated by controls on the handle 14. In particular, a rotation knob 30 causes rotation of the shaft 16 about its longitudinal axis, and hence rotation of the staple applying assembly 12. Additional positioning is enabled at an articulation joint 32 in the shaft 16 that pivots the staple applying assembly 12 in an arc from the longitudinal axis of the shaft 16, thereby allowing placement behind an organ or allowing other instruments such as an endoscope (not shown) to be oriented behind the staple applying assembly 12. This articulation is advantageously effected by an articulation control switch 34 on the handle 14 that transmits an electrical signal to the articulation joint 32 to an Electroactive Polymer (EAP) actuator 36, powered by an EAP controller and power supply 38 contained within the handle 14.

[0036] Once positioned with tissue in the staple applying assembly 12, a surgeon closes the anvil 22 by drawing a closure trigger 40 proximally toward a pistol grip 42. Once clamped thus, the surgeon may grasp a more distally presented firing trigger 44, drawing it back to effect firing of the staple applying assembly 12, which in some applications is achieved in one single firing stroke and in other applications by multiple firing strokes. Firing accomplishes simultaneously stapling of at least two rows of staples while severing the tissue therebetween.

[0037] Retraction of the firing components may be automatically initiated upon full travel. Alternatively, a retraction lever 46 may be drawn aft to effect retraction. With the firing components retracted, the staple applying assembly 12 may be unclamped and opened by the surgeon slightly drawing the closure trigger 40 aft toward the pistol grip 42 and depressing a closure release button 48 and then releasing the closure trigger 40, thereby releasing the two stapled ends of severed tissue from the staple applying assembly 12.

[0038] Staple Applying Assembly.

[0039] While an articulation joint 32 is depicted in FIG. 1, for clarity and as an alternative application, the surgical stapling instrument 10 of FIGS. 2-14 omit an articulation joint 32. It should be appreciated, however, that aspects of the present invention have particular advantages for articulation as described below with regard to FIGS. 15-18.

[0040] In FIGS. 1-3, the staple applying assembly 12 accomplishes the functions of clamping onto tissue, driving staples and severing tissue by two distinct motions transferred longitudinally down the shaft 16 over a shaft frame 70. This shaft frame 70 is proximally attached to the handle 14 and coupled for rotation with the rotation knob 30. An illustrative multi-stroke handle 14 for the surgical stapling and severing instrument 10 of FIG. 1 is described in greater detail in the co-pending and co-owned U.S. patent application entitled "SURGICAL STAPLING INSTRUMENT INCORPORATING A MULTISTROKE FIRING POSITION INDICATOR AND RETRACTION MECHANISM" to Swayze and Shelton, Ser. No. 10/374,026, the disclosure of which is hereby incorporated by reference in its entirety, with additional features and variation as described herein. While a multi-stroke handle 14 advantageously supports applications with high firing forces over a long distance, applications consistent with the present invention may incorporate a single firing stroke, such as described in co-pending and commonly owned U.S. patent application "SURGICAL STAPLING INSTRUMENT HAVING SEPARATE DISTINCT CLOSING AND FIRING SYSTEMS" to Frederick E. Shelton IV, Michael E. Setser, and Brian J. Hemmelgarn, Ser. No. 10/441,632, the disclosure of which is hereby incorporated by reference in its entirety.

[0041] With particular reference to FIG. 3, the distal end of the shaft frame 70 is attached to the staple channel 18. The anvil 22 has a proximal pivoting end 72 that is pivotally received within a proximal end 74 of the staple channel 18, just distal to its engagement to the shaft frame 70. The pivoting end 72 of the anvil 22 includes a closure feature 76 proximate but distal to its pivotal attachment with the staple channel 18. Thus, a closure tube 78, whose distal end includes a horseshoe aperture 80 that engages this closure feature 76, selectively imparts an opening motion to the anvil 22 during proximal longitudinal motion and a closing motion to the anvil 22 during distal longitudinal motion of the closure tube 78 sliding over the shaft frame 70 in response to the closure trigger 40.

[0042] The shaft frame 70 encompasses and guides a firing motion from the handle 14 through a longitudinally reciprocating, two-piece knife and firing bar 90. In particular, the shaft frame 70 includes a longitudinal firing bar slot 92 that receives a proximal portion of the two-piece knife and firing bar 90, specifically a laminate tapered firing bar 94. It should be appreciated that the laminated tapered firing bar 94 may be substituted with a solid firing bar or of other materials in applications not intended to pass through an articulation joint, such as depicted in FIGS. 2-14.

[0043] An E-beam 102 is the distal portion of the two-piece knife and firing bar 90, which facilitates separate closure and firing as well as spacing of the anvil 22 from the elongate staple channel 18 during firing. With particular reference to FIGS. 3-4, in addition to any attachment treatment such as brazing or an adhesive, the knife and firing bar 90 are formed of a female vertical attachment aperture 104 proximally formed in the E-beam 102 that receives a corresponding male attachment member 106 distally presented by the laminated tapered firing bar 94, allowing each portion to be formed of a selected material and process suitable for their disparate functions (e.g., strength, flexibility, friction). The E-beam 102 may be advantageously formed of a material having suitable material properties for

forming a pair of top pins 110, a pair of middle pins 112 and a bottom pin or foot 114, as well as being able to acquire a sharp cutting edge 116. In addition, integrally formed and proximally projecting top guide 118 and middle guide 120 bracketing each vertical end of the cutting edge 116 further define a tissue staging area 122 assisting in guiding tissue to the sharp cutting edge 116 prior to being severed. The middle guide 120 also serves to engage and fire the staple applying apparatus 12 by abutting a stepped central member 124 of a wedge sled 126 (FIG. 5) that effects staple formation by the staple applying assembly 12, as described in greater detail below.

[0044] Forming these features (e.g., top pins 110, middle pins 112, and bottom foot 114) integrally with the E-beam 102 facilitates manufacturing at tighter tolerances relative to one another as compared to being assembled from a plurality of parts, ensuring desired operation during firing and/or effective interaction with various lockout features of the staple applying assembly 12.

[0045] In FIGS. 6-7, the surgical stapling instrument 10 is shown open, with the E-beam 102 fully retracted. During assembly, the lower foot 114 of the E-beam 102 is dropped through a widened hole 130 in the staple channel 18 and the E-beam 102 is then advanced such that the E-beam 102 slides distally along a lower track 132 formed in the staple channel 18. In particular, the lower track 132 includes a narrow slot 133 that opens up as a widened slot 134 on an undersurface of the staple channel 18 to form an inverted T-shape in lateral cross section, as depicted particularly in FIGS. 7 and 8, which communicates with the widened hole 130. Once assembled, the components proximally coupled to the laminate tapered firing bar 94 do not allow the lower foot 114 to proximally travel again to the widened hole 130 to permit disengagement.

[0046] In FIG. 9, the laminate tapered firing bar 94 facilitates insertion of the staple applying assembly 12 through a trocar. In particular, a more distal, downward projection 136 raises the E-beam 102 when fully retracted. This is accomplished by placement of the downward projection 136 at a point where it cams upwardly on a proximal edge of the widened hole 130 in the staple channel 18.

[0047] In FIG. 10, the laminate tapered firing bar 94 also enhances operation of certain lockout features that may be incorporated into the staple channel 18 by including a more proximal upward projection 138 that is urged downwardly by the shaft frame 70 during an initial portion of the firing travel. In particular, a lateral bar 140 is defined between a pair of square apertures 142 in the shaft frame 70 (FIG. 3). A clip spring 144 that encompasses the lateral bar 140 downwardly urges a portion of the laminate tapered firing bar 94 projecting distally out of the longitudinal firing bar slot 92, which ensures certain advantageous lockout features are engaged when appropriate. This urging is more pronounced or confined solely to that portion of the firing travel when the upward projection 138 contacts the clip spring 144.

[0048] In FIGS. 6-7, the E-beam 102 is retracted with the top pins 110 thereof residing within an anvil pocket 150 near the pivoting proximal end of the anvil 22. A downwardly open vertical anvil slot 152 (FIG. 2) laterally widens in the anvil 22 into an anvil internal track 154 that captures the top pins 110 of the E-beam 102 as they distally advance during firing, as depicted in FIGS. 9-10, affirmatively spacing the

anvil 22 from the staple channel 18. Thus, with the E-beam 102 retracted, the surgeon is able to repeatedly open and close the staple applying assembly 12 until satisfied with the placement and orientation of tissue captured therein for stapling and severing, yet the E-beam 102 assists in proper positioning of tissue even for a staple applying assembly 12 of reduced diameter and correspondingly reduced rigidity.

[0049] In FIGS. 2-3, 5-6, 8-14, the staple applying assembly 12 is shown with the replaceable staple cartridge 20 that includes the wedge sled 126. Longitudinally aligned and parallel plurality of downwardly open wedge slots 202 (FIG. 8) receive respective wedges 204 integral to the wedge sled 126. In FIGS. 8-10, the wedge sled 126 thus cams upwardly a plurality of staple drivers 206 that are vertically slidable within staple driver recesses 208. In this illustrative version, each staple driver 206 includes two vertical prongs, each translating upwardly into a respective staple hole 210 to upwardly force out and deform a staple 23 resting thereupon against a staple forming surface 214 (FIG. 10) of the anvil 22. A central firing recess 216 (FIG. 3) defined within the staple cartridge 20 proximate to the staple channel 18 allows the passage of the bottom, horizontal portion 218 (FIG. 5) of the wedge sled 126 as well as the middle pins 112 of the E-beam 102. Specifically, a staple cartridge tray 220 (FIGS. 3, 8) attaches to and underlies a polymer staple cartridge body 222 that has the staple driver recesses 208, staple holes 210, and central firing recess 216 formed therein. As staples 23 are thus formed to either side, the sharp cutting edge 116 enters a vertical through slot 230 passing through the longitudinal axis of the staple cartridge 20, excepting only a most distal end thereof.

[0050] Firing the staple applying assembly 12 begins as depicted in FIG. 10 with the two-piece knife and firing bar 90 proximally drawn until the downward projection 136 cams the middle guide 120 on the E-beam 102 upward and aft, allowing a new staple cartridge 20 to be inserted into the staple channel 18 when the anvil 22 is open as depicted in FIGS. 2, 6.

[0051] In FIG. 11, the two-piece knife and firing bar 90 has been distally advanced a small distance, allowing the downward projection 136 to drop into the widened hole 130 of the lower track 132 under the urging of the clip spring 144 against the upward projection 138 of the laminate tapered firing bar 94. The middle guide 120 prevents further downward rotation by resting upon the stepped central member 124 of the wedge sled 126, thus maintaining the middle pin 112 of the E-beam within the central firing recess 216.

[0052] In FIG. 12, the two-piece knife and firing bar 90 has been distally fired, advancing the wedge sled 126 to cause formation of staples 23 while severing tissue 242 clamped between the anvil 22 and staple cartridge 20 with the sharp cutting edge 116. Thereafter, in FIG. 13, the two-piece knife and firing bar 90 is retracted, leaving the wedge sled 126 distally positioned.

[0053] In FIG. 14, the middle pin 112 is allowed to translate down into a lockout recess 240 formed in the staple channel 18 (also see FIGS. 7, 10). Thus, the operator would receive a tactile indication as the middle pin 112 encounters the distal edge of the lockout recess 240 when the wedge sled 126 (not shown in FIG. 14) is not proximally positioned (i.e., missing staple cartridge 20 or spent staple cartridge 20).

[0054] In FIG. 1, an articulation joint 32 is depicted that advantageously benefits from the flexible strength of the two-piece knife and firing bar 90. In FIGS. 15-18, the articulation joint 32 is depicted as a flex neck joint 300 formed by vertebral column body 302 having laterally symmetric pairs of arcing recesses 304 that allow articulation in an articulation plane. It is generally known to simultaneously compress and expand respective lateral sides 306, 308 by selective movement of control rods (not shown) that longitudinally pass through the respective lateral sides 306, 308. Depicted, however, are EAP plate actuators 310, 312, each capable of powered deflection to one or both lateral directions.

[0055] A central passage 320 (FIG. 16) defined longitudinally through the vertebral column body 302 receives a pair of support plates 322, 324 that prevent buckling and binding of the laminate tapered firing bar 94. In the illustrative version, each support plate 322, 324 has a proximal fixed end 326 (FIG. 15) and a sliding end 328 to accommodate changes in radial distance during articulation. Having a firing bar 94 of a thinner thickness is thus supported.

[0056] While the present invention has been illustrated by description of several embodiments and while the illustrative embodiments have been described in considerable detail, it is not the intention of the applicant to restrict or in any way limit the scope of the appended claims to such detail. Additional advantages and modifications may readily appear to those skilled in the art.

[0057] For example, while there are a number of advantages to having a wedge sled integral to a staple cartridge, in some applications consistent with aspects of the present invention, the wedge sled may be integral instead to an E-beam. For instance, an entire end effector may be replaceable rather than just the staple cartridge.

What is claimed is:

1. A surgical instrument comprising:

- a handle portion operable to produce a firing motion; and
- an implement portion responsive to the firing motions from the handle portion, the implement portion comprising:
 - an elongate channel coupled to the handle portion and including a channel slot,
 - a staple cartridge received by the elongate channel and incorporating a proximally positioned wedge member aligned to cam upward a driver supporting a staple,
 - an anvil pivotally coupled to the elongate channel and including an anvil channel,
 - a firing device including a distally presented cutting edge longitudinally received between the elongate channel and the anvil, an upper member engageable to the anvil channel, a lower member engaging the channel slot, and a middle member operable to actuate the staple cartridge by distally translating the wedge member of the staple cartridge, the firing device positively engaging both the elongate channel and the anvil during longitudinal firing travel to provide spacing therebetween for staple formation,

- an articulation joint proximally coupled to the elongate channel, and

- a thinned firing strip proximally attached to the firing device for transferring the firing motion from the handle portion through the articulation joint.

2. The surgical instrument of claim 1, wherein the anvil forms a pivotal attachment to the elongate channel inwardly biased at respective distal ends to assist the firing device in affirmatively spacing between the anvil and elongate channel during actuation of the staple cartridge.

3. The surgical instrument of claim 1, wherein the staple cartridge is a selected type of a plurality of staple cartridge types, each staple cartridge type characterized by a thickness selected for a desired spacing between the anvil and elongate channel and characterized by staples having a length suitable for the desired spacing.

4. The surgical instrument of claim 3, wherein the wedge member comprises a wedge sled having a plurality of connected camming wedges each having a preselected height configured for the selected type of staple cartridge, the middle member of the firing device oriented to abut each of the plurality of staple cartridge types.

5. A surgical instrument comprising:

- a handle portion operable to produce a firing motion and a closing motion; and

- an implement portion responsive to the firing motions from the handle portion and diametrically dimensioned for endo-surgical use, the implement portion comprising:

- a shaft coupled to the handle portion operable to separately transfer the firing motion and the closing motion,

- an elongate channel coupled to the shaft and including a channel slot,

- an anvil pivotally coupled to the elongate channel, responsive to the closing motion from the shaft, and including an anvil channel,

- a firing device including a distally presented cutting edge longitudinally received between the elongate channel and the anvil, the firing device including a lower portion slidingly engaged to the elongate channel and an upper portion positioned to slidingly engage the anvil during firing, engagement of the firing device to the elongate channel and the anvil maintaining a spacing therebetween; and

- a thinned strip proximally attached to the firing device operable to transfer the firing motion to the firing device.

6. The surgical instrument of claim 5, further comprising a staple cartridge engaged by the elongate channel and including a proximally opened slot for receiving the cutting edge of the firing device, the staple cartridge including a plurality of staples cammed upwardly by the distal longitudinal movement of the firing mechanism.

7. The surgical instrument of claim 6, wherein the staple cartridge further includes a plurality of drivers supporting the plurality of staples and a wedge sled responsive to the distal longitudinal movement of the firing mechanism to cam upwardly the drivers and thus form the plurality of staples against the anvil.

8. The surgical instrument of claim 5, wherein the shaft includes an articulation mechanism through which the thinned strip bends and longitudinally translates.

9. The surgical instrument of claim 6, wherein the staple cartridge is a selected type of a plurality of staple cartridge types, each staple cartridge type characterized by a thickness selected for a desired spacing between the anvil and elongate channel and characterized by staples having a length suitable for the desired spacing.

10. The surgical instrument of claim 9, wherein the wedge sled comprises a plurality of connected camming wedges each having a preselected height configured for the selected type of staple cartridge, the middle member of the firing device oriented to abut each of the plurality of staple cartridge types.

11. The surgical instrument of claim 5, wherein the firing device is configured to affirmatively space the anvil from the elongate channel during longitudinal travel between the anvil and elongate channel by including a lower portion having an upper surface and a lower surface that slidingly engage the elongate channel.

12. The surgical instrument of claim 11, wherein the lower portion of the firing device comprises a lower pin having the upper surface abutting the elongate channel and the lower portion further comprises a middle pin having the lower surface opposingly abutting the elongate channel.

13. The surgical instrument of claim 12, wherein the firing device further comprises an upper member having an upper surface and a lower surface that longitudinally slidingly engage the anvil.

14. The surgical instrument of claim 13, wherein the anvil includes an internal longitudinal slot having a narrowed vertical slot, and wherein the firing device translates in the narrowed vertical slot and includes an upper member having upper and lower surfaces that reside within the internal longitudinal slot for affirmatively spacing the anvil from the elongate channel.

15. The surgical instrument of claim 5, wherein the firing device is configured to affirmatively space the anvil from the elongate channel during longitudinal travel between the anvil and elongate channel by including an upper member having an upper surface and a lower surface that longitudinally slidingly and opposingly engage the anvil.

16. The surgical instrument of claim 15, wherein the anvil includes a longitudinal slot having an upper surface and a lower surface that slidingly abut respectively the lower surface and upper surface of the upper member of the firing device.

17. The surgical instrument of claim 16, wherein the longitudinal slot comprises an internal longitudinal channel communicating with a narrowed vertical slot, and wherein the firing device translates in the narrowed vertical slot and includes an upper member having the upper and lower surfaces that reside within the internal longitudinal channel for affirmatively spacing the anvil from the elongate channel.

18. A surgical instrument, comprising:

a handle means for producing a closing motion and a firing motion;

a clamping means responsive to the closing motion to clamp tissue;

a firing means responsive to the firing motion for vertically spacing the clamping means and for causing severing and stapling of clamped tissue therein; and

an articulation mechanism operably configured to articulate the clamping means relative to the handle means; and

a thinned firing strip proximally attached to the firing means for bending through the articulation mechanism and for longitudinally transferring the firing motion.

19. The surgical instrument of claim 18, wherein the anvil includes an internal longitudinal slot having a narrowed inward opening, the firing device translating within the narrowed inward opening and having the upper member slidingly engaged within the longitudinal slot.

20. The surgical instrument of claim 19, further comprising a closure member operatively configured to longitudinally transfer the closure motion to the end effector to inwardly bias distal ends of the anvil and the elongate channel to assist the firing device in affirmatively spacing the anvil and elongate channel during actuation of the staple cartridge.

* * * * *

专利名称(译)	铰接式外科缝合器械，包括两件式电子束发射机构		
公开(公告)号	US20050263562A1	公开(公告)日	2005-12-01
申请号	US10/955042	申请日	2004-09-30
[标]申请(专利权)人(译)	冯检谢尔顿IVè DOLL凯文 - [R MORGAN杰里 - [R 塞斯特迈克尔·		
申请(专利权)人(译)	冯检谢尔顿IVè DOLL凯文 - [R MORGAN杰里 - [R 塞斯特迈克尔·		
当前申请(专利权)人(译)	ETHICON - 内切手术，INC.		
[标]发明人	SHELTON FREDERICK E IV DOLL KEVIN ROSS MORGAN JERRY R SETSER MICHAEL EARL		
发明人	SHELTON, FREDERICK E. IV DOLL, KEVIN ROSS MORGAN, JERRY R. SETSER, MICHAEL EARL		
IPC分类号	A61B17/00 A61B17/04 A61B17/068 A61B17/072 A61B17/28 A61B17/32		
CPC分类号	A61B17/0686 A61B17/07207 A61B17/32 A61B2017/00292 A61B2017/00309 A61B2017/2927 A61B2017/0725 A61B2017/07271 A61B2017/07278 A61B2017/2905 A61B2017/07214		
优先权	60/591694 2004-07-28 US		
其他公开文献	US7380696		
外部链接	Espacenet USPTO		

摘要(译)

适用于腹腔镜和内窥镜临床手术的外科切断和缝合器械将组织夹在由砧座枢转地相对的细长通道的末端执行器内。电子束击发杆向远侧移动通过夹紧的末端执行器以切断组织并在切口的每一侧驱动钉。电子束击发杆肯定地将砧座与细长通道隔开，以确保适当形成的闭合钉，特别是当夹紧一定量的组织时，其不足以使端部执行器间隔开。特别地，击发杆的上销纵向移动通过砧座槽，并且通道槽被捕获在击发杆的下帽和中间销之间，以确保最小间距。从加厚的远端部分和变薄的近端条带形成电子束增强了可制造性并且便于在这种铰接手术器械中使用。

