



(19) **United States**

(12) **Patent Application Publication**
Bendall

(10) **Pub. No.: US 2003/0212308 A1**

(43) **Pub. Date: Nov. 13, 2003**

(54) **TUBE GRIPPER INTEGRAL WITH
CONTROLLER FOR ENDOSCOPE OR
BORESCOPE**

(22) Filed: **May 13, 2002**

Publication Classification

(75) Inventor: **Clark A. Bendall, Syracuse, NY (US)**

(51) **Int. Cl.⁷ A61B 1/00**

(52) **U.S. Cl. 600/131; 600/102**

Correspondence Address:
**WALL MARJAMA & BILINSKI
101 SOUTH SALINA STREET
SUITE 400
SYRACUSE, NY 13202 (US)**

(57) **ABSTRACT**

A probe controller is integral with a gripper for the probe's insertion tube. The gripper is easily operated with one hand, permitting a user to hold, release, and insert the insertion tube with the same hand that operates the controls on the controller, thus freeing the user's other hand to feed the insertion tube into the opening, perform other operations, or optionally to operate the controls.

(73) Assignee: **Everest VIT**

(21) Appl. No.: **10/144,503**

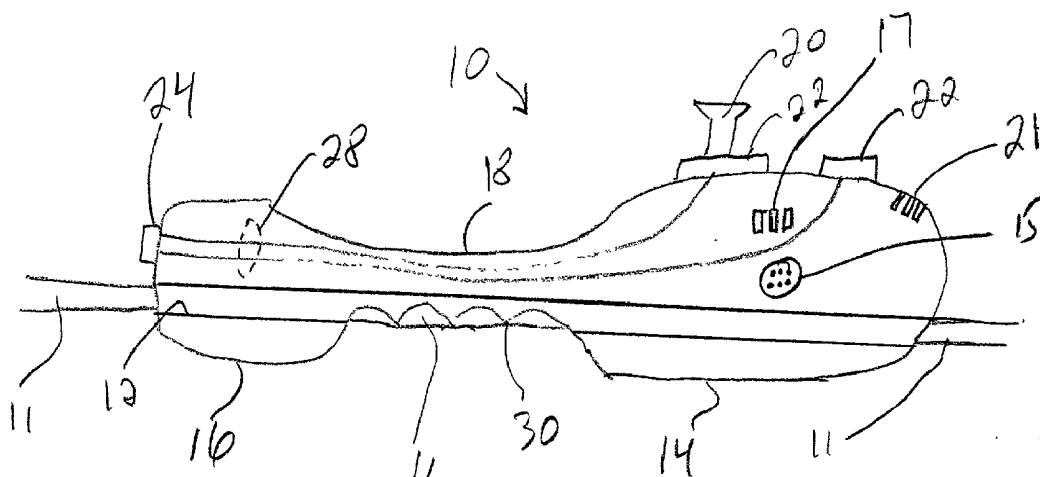

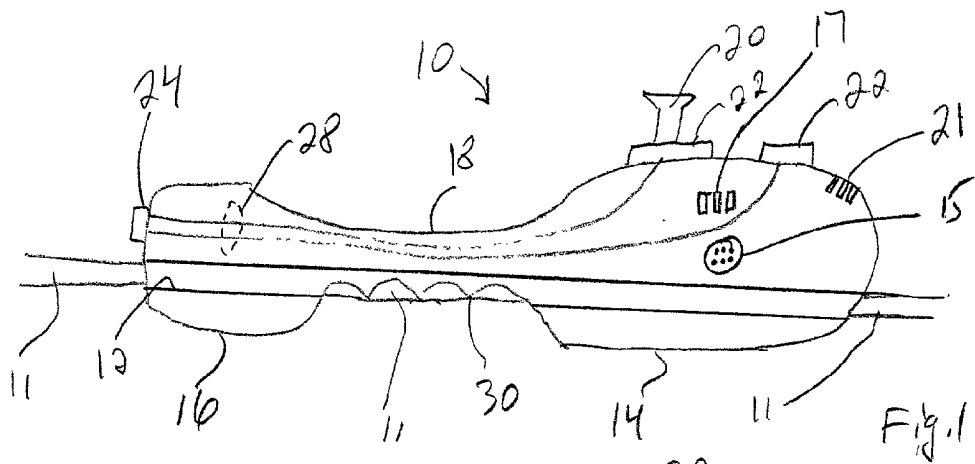

Fig. 1

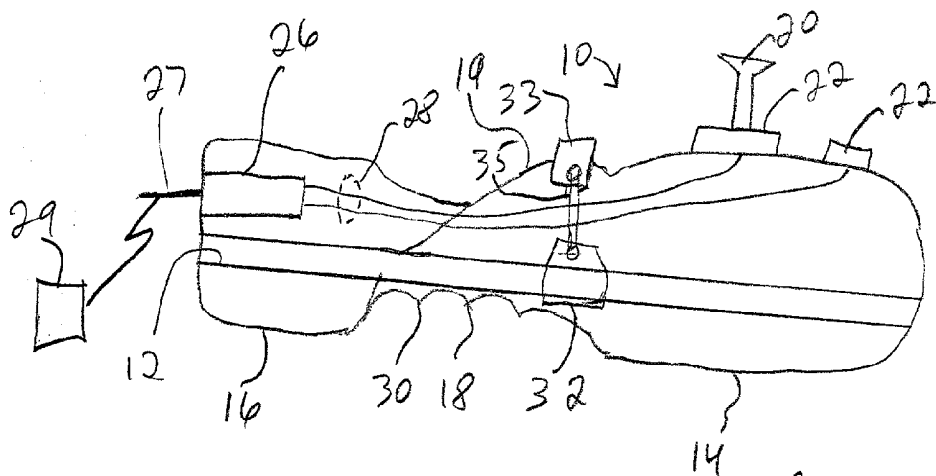

Fig. 2

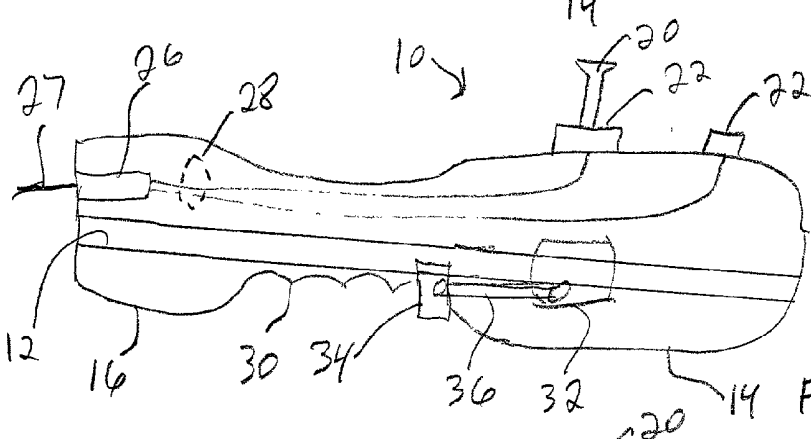

Fig. 3

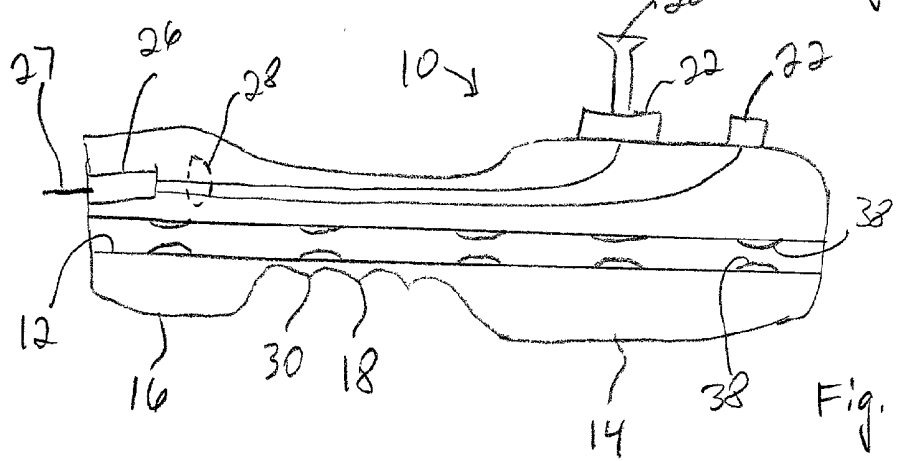
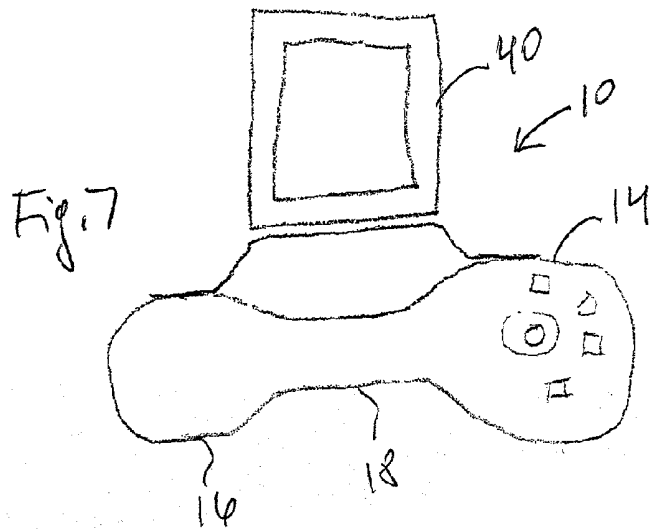
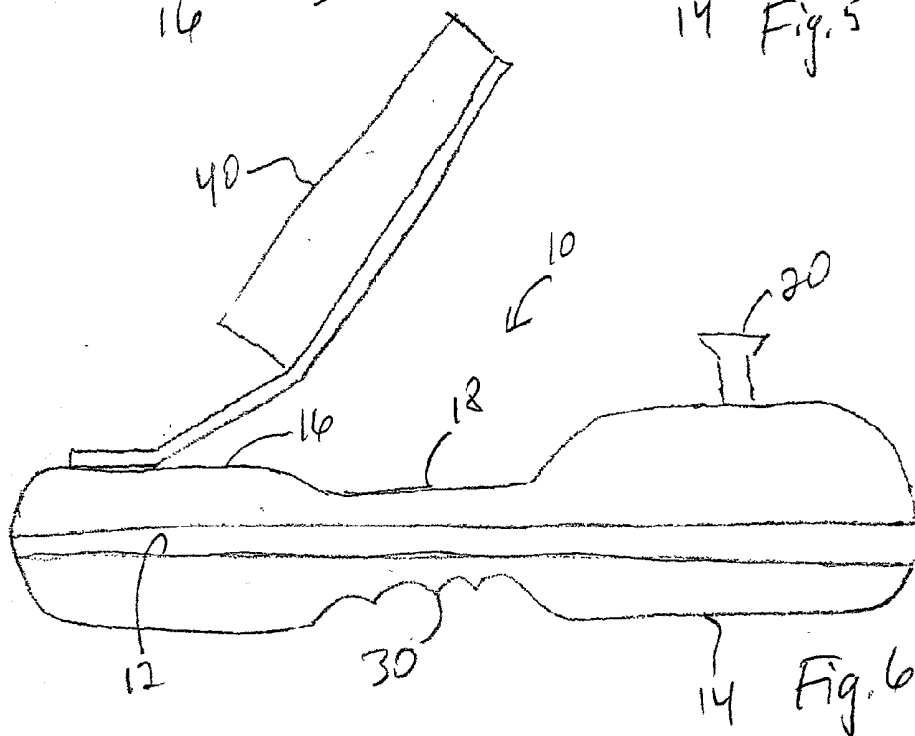
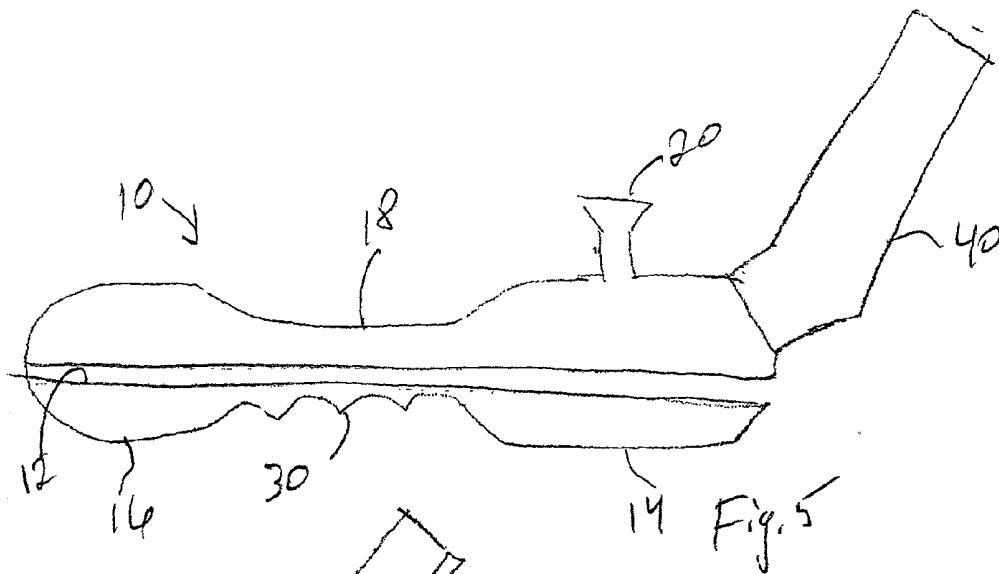

Fig. 4



TUBE GRIPPER INTEGRAL WITH CONTROLLER FOR ENDOSCOPE OR BORESCOPE

DETAILED DESCRIPTION OF THE PREFERRED EMBODIMENT

FIELD OF THE INVENTION

[0001] This invention relates generally to the field of endoscope/borescope controllers, and more particularly to a tube gripper integral with a controller for an endoscope/borescope.

BACKGROUND OF THE INVENTION

[0002] Video endoscopes or borescopes, hereinafter referred to as probes, generally have a flexible insertion tube with a diameter of one inch or less. The tube is usually pushed into inaccessible areas so they can be visually inspected. Feeding the insertion tube into an area is difficult with one hand as the tube tends to slide out of the area of interest when it is released. One hand is often used to hold the position of the insertion tube steady as the other hand moves down the tube in preparation for the next push. Most video probes also have a control section which has controls for articulating the tip of the probe as well as buttons for activating other system functions. It is difficult for the user to hold and/or use the control section while pushing the insertion tube.

SUMMARY OF THE INVENTION

[0003] Briefly stated, a probe controller is integral with a gripper for the probe's insertion tube. The gripper is easily operated with one hand, permitting a user to hold, release, and insert the insertion tube with the same hand that operates the controls on the controller, thus freeing the user's other hand to feed the insertion tube into the opening, perform other operations, or optionally to operate the controls.

[0004] According to an embodiment of the invention, a tube gripper for a probe includes a tube channel running lengthwise through the tube gripper for receiving an insertion tube of the probe; control means, integral with the tube gripper, for controlling at least one function of the probe; and gripping means for frictively connecting the tube gripper to the insertion tube.

BRIEF DESCRIPTION OF THE DRAWINGS

[0005] FIG. 1 shows a side cross-sectional view of an embodiment of the invention;

[0006] FIG. 2 shows a side cross-sectional view of an embodiment of the invention;

[0007] FIG. 3 shows a side cross-sectional view of an embodiment of the invention;

[0008] FIG. 4 shows a side cross-sectional view of an embodiment of the invention;

[0009] FIG. 5 shows a side view of an embodiment of the invention with a display mounted on a front portion thereof;

[0010] FIG. 6 shows a side view of an embodiment of the invention with a display mounted on a rear portion thereof; and

[0011] FIG. 7 shows a top view of an embodiment of the invention with a display mounted on a side portion thereof.

[0012] Referring to FIGS. 1-2, an embodiment of an insertion tube gripper 10 includes a tube channel 12 running throughout its length. Tube channel 12 is preferably sized to accommodate a typical insertion tube 11 of a probe. A front portion 14 of tube gripper 10 contains various probe controls such as a joystick 20 and control buttons 22. Other possible controls include a track ball, mouse, touch screen, etc. A rear portion 16 of tube gripper 10 optionally includes a wired connection 24 to a probe base station 29. Alternatively, rear portion 16 contains a small radio transceiver 26 with an antenna 27 for wireless communication to probe base station 29. Connector 24 or transceiver 26 is preferably connected to a joystick 20 and control buttons 22 via a cable or cables 28. Power may be provided to the probe controls via wired connection 24 or using a battery.

[0013] Insertion tube 11 only carries the raw video signal from the imager of the probe to base station 29. The viewable video is sent from base station 29 to the probe controls either via RF or wired link in either analog or digital format.

[0014] Functions and settings controlled by joystick 20 may include articulation of the tip of the endoscope, menu navigation, text entry, image panning, image selection, cursor positioning, text positioning, zoom level, illumination level, image brightness control, or other such functions. Control buttons 22 may provide any of the possible joystick-controlled functions plus others such as controlling image inversion, image storage/recall, enter/cancel functions, articulation mode changes, video switching control, measurement initiation/selection, operating mode selection and the like. Joystick 20 may also include an integral pushbutton which may provide any of the control-button functions. Another control mechanism may be used in place of joystick 20 such as a mouse pad or track ball. A single board preferably located in the joystick/button area would preferably hold the control mechanisms, such as joystick 20 and control buttons 22, as well as transceiver 26 and a microprocessor (not shown) if desired.

[0015] A middle portion 18 of tube gripper 10 is preferably shaped to accommodate a user's hand, with a molded portion 30 conforming to the user's fingers as they are wrapped around tube gripper 10. In middle portion 18, tube channel 12 is exposed to the outside so that at least one of the user's fingers or thumbs grips insertion tube 11 directly. The user then slides tube gripper 10 up and down insertion tube 11 as desired.

[0016] An optional video display connector 15 permits attaching a video display 40 (FIGS. 5-7), thus allowing video display 40 to be located near the user and connected via a cable to tube gripper 10 such that the cable need not be run back to probe base station 29. Connector 15 could attach in a number of places including the front end near the control buttons, the rear, or to the side. An optional microphone 21 permits comment recording and voice control. An optional speaker 17 permits playback of comments and/or button activation feedback.

[0017] Referring to FIG. 2, in an alternate embodiment, tube channel 12 is not exposed to the outside in middle portion 18, but a mechanical gripping mechanism 32,

located in middle portion 18 or front portion 14, is connected to a thumb trigger 33 by a mechanical linkage 35. Depressing thumb trigger 33 causes gripping mechanism 32 to clamp onto insertion tube 11. Alternately, releasing thumb trigger 33 causes gripping mechanism 32 to release insertion tube 11. Gripping mechanism 32 may also be designed such that depressing thumb trigger 33 releases insertion tube 11, and releasing thumb trigger 33 causes gripping mechanism 32 to clamp onto insertion tube 11. Molded portion 30 optionally includes a thumb rest 19.

[0018] Referring to FIG. 3, in another embodiment similar to the embodiment of FIG. 2, tube channel 12 is not exposed to the outside in middle portion 18, but a mechanical gripping mechanism 32, preferably located in front portion 14, is connected to a finger trigger 34 by a mechanical linkage 36. Depressing finger trigger 34 causes gripping mechanism 32 to clamp onto insertion tube 11. Alternately, releasing finger trigger 34 causes gripping mechanism 32 to release insertion tube 11. Mechanical linkage 36 is optionally located in rear portion 16 of tube gripper 10. Gripping mechanism 32 may also be designed such that depressing finger trigger 34 releases insertion tube 11, and releasing finger trigger 34 causes gripping mechanism 32 to clamp onto insertion tube 11.

[0019] Referring to FIG. 4, another embodiment has neither an exposed tube channel nor a finger trigger. Instead, fixed or adjustable friction applicators 38 are located within tube channel 12 which provide steady friction between tube gripper 10 and insertion tube 11. Friction applicators could be small brushes or other materials which have a lower sliding coefficient of friction than static coefficient of friction.

[0020] Referring to FIG. 5, a display 40 is shown mounted on front portion 14 of tube gripper 10. In FIG. 6, display 40 is shown mounted on rear portion 16 of tube gripper 10. In FIG. 7, display 40 is shown side mounted onto tube gripper 10. The purpose of these different mounting positions is so that display 40 is in the same vicinity as the controls, so that users don't have to turn their head/body to look from the controls to display 40. The controls and display 40 can also be close to the port through which the probe is inserted to further reduce head/eye/body movement.

[0021] In the embodiments of FIGS. 1-7, channel 12 of tube gripper 10 optionally opens along a seam on the underside of tube gripper 10 which allows the user to clamp tube gripper 10 onto insertion tube 11. Tube channel 12 may require that insertion tube 11 be inserted from the front or rear of the device. Alternatively, an access panel may be provided which, when opened, allows insertion tube 11 to be placed in tube channel 12 at any point along insertion tube 11. Tube channel 12 may also contain flexible or movable components between the tube channel itself and the bottom side of the gripper/controller through which insertion tube 11 may be forced to place insertion tube 11 in tube channel 12 thus allowing the gripper/controller to be attached to insertion tube 11 at any point.

[0022] While the present invention has been described with reference to a particular preferred embodiment and the accompanying drawings, it will be understood by those skilled in the art that the invention is not limited to the preferred embodiment and that various modifications and the like could be made thereto without departing from the scope of the invention as defined in the following claims.

What is claimed is:

1. A tube gripper for a probe, comprising:
 - a tube channel running lengthwise through said tube gripper for receiving an insertion tube of said probe;
 - control means, integral with said tube gripper, for controlling at least one function of said probe; and
 - gripping means for frictively connecting said tube gripper to said insertion tube.
2. A tube gripper according to claim 1, wherein said control means includes a joystick and at least one button.
3. A tube gripper according to claim 2, further comprising means for connecting said control means to a probe base unit.
4. A tube gripper according to claim 3, wherein said means for connecting includes a cable.
5. A tube gripper according to claim 3, wherein said means for connecting includes means for wireless data transfer between said control means and said base unit.
6. A tube gripper according to claim 1, wherein said gripping means comprises an opening in a middle portion of said tube gripper such that said tube channel is exposed such that at least one finger of a user frictively connects said tube gripper to said insertion tube.
7. A tube gripper according to claim 1, wherein said gripping means comprises:
 - a mechanical gripping mechanism inside said tube gripper; and
 - one of a finger and thumb trigger mechanically linked to said gripping mechanism such that pressing said one of said finger and thumb trigger frictively connects said tube gripper to said insertion tube.
8. A tube gripper according to claim 7, wherein said mechanical gripping mechanism is disposed in a front portion of said tube gripper.
9. A tube gripper according to claim 7, wherein said mechanical gripping mechanism is disposed in a middle portion of said tube gripper.
10. A tube gripper according to claim 1, wherein said gripping means comprises:
 - a mechanical gripping mechanism inside said tube gripper; and
 - one of a finger and thumb trigger mechanically linked to said gripping mechanism such that releasing said one of a finger and thumb trigger frictively connects said tube gripper to said insertion tube.
11. A tube gripper according to claim 10, wherein said mechanical gripping mechanism is disposed in a front portion of said tube gripper.
12. A tube gripper according to claim 10, wherein said mechanical gripping mechanism is disposed in a middle portion of said tube gripper.
13. A tube gripper according to claim 1, wherein a middle portion of said tube gripper is shaped to conform to a hand grip of a user.
14. A tube gripper according to claim 1, wherein said gripping means includes a material affixed to an inside of said tube channel which has a lower sliding coefficient of friction than a static coefficient of friction.
15. A tube gripper according to claim 1, further comprising a video display detachably mounted on said tube gripper.

16. A tube gripper according to claim 1, wherein said tube channel receives said insertion tube only through an end of said tube channel.

17. A tube gripper according to claim 1, wherein said tube channel receives said insertion tube through a lengthwise slit in said tube channel.

18. A tube gripper according to claim 1, further comprising a movable panel which permits said insertion tube to be placed in said tube channel at any point along said insertion tube.

19. A tube gripper according to claim 1, further comprising a displaceable barrier along an underside of said tube

channel such that said insertion tube may be forced past a displaceable barrier into said tube channel at any point along said insertion tube.

20. A tube gripper according to claim 1, further comprising a video display connector on said tube gripper.

21. A tube gripper according to claim 1, further comprising a microphone within said tube gripper.

22. A tube gripper according to claim 1, further comprising a loudspeaker within said tube gripper.

* * * * *

专利名称(译)	管夹与控制器一体化，用于内窥镜或管道镜		
公开(公告)号	US20030212308A1	公开(公告)日	2003-11-13
申请号	US10/144503	申请日	2002-05-13
[标]申请(专利权)人(译)	EVEREST VIT		
申请(专利权)人(译)	EVEREST VIT		
当前申请(专利权)人(译)	GE检测科技，LP		
[标]发明人	BENDALL CLARK A		
发明人	BENDALL, CLARK A.		
IPC分类号	A61B1/01 A61B1/00		
CPC分类号	A61B1/00052 A61B1/00105 A61B1/00066		
其他公开文献	US6830545		
外部链接	Espacenet USPTO		

摘要(译)

探头控制器与探头插入管的夹具是一体的。夹具易于用一只手操作，允许使用者用操作控制器上的控制器的同一只手握住，释放和插入插入管，从而释放使用者的另一只手将插入管送入开口，执行其他操作，或者可选地操作控件。

