



US008251889B2

(12) **United States Patent**
Scott

(10) **Patent No.:** **US 8,251,889 B2**
(45) **Date of Patent:** **Aug. 28, 2012**

(54) **APPARATUS AND METHOD FOR INTRA-ABDOMINALLY MOVING A FIRST INTERNAL ORGAN TO A POSITION AWAY FROM A SECOND INTERNAL ORGAN AND THEN HOLDING THE FIRST INTERNAL ORGAN IN THE POSITION WITHOUT MANUAL INPUT**

(75) Inventor: **J. Stephen Scott**, Wentzville, MO (US)

(73) Assignee: **MIS Solutions, Inc.**, New York, NY (US)

(*) Notice: Subject to any disclaimer, the term of this patent is extended or adjusted under 35 U.S.C. 154(b) by 0 days.

(21) Appl. No.: **13/203,396**

(22) PCT Filed: **Feb. 25, 2010**

(86) PCT No.: **PCT/US2010/025425**

§ 371 (c)(1),
(2), (4) Date: **Nov. 1, 2011**

(87) PCT Pub. No.: **WO2010/099327**

PCT Pub. Date: **Sep. 2, 2010**

(65) **Prior Publication Data**

US 2012/0078057 A1 Mar. 29, 2012

(51) **Int. Cl.**
A61B 1/32 (2006.01)

(52) **U.S. Cl.** **600/37; 600/204**

(58) **Field of Classification Search** **600/37, 600/201-246**

See application file for complete search history.

(56) **References Cited**

U.S. PATENT DOCUMENTS

5,362,294	A	11/1994	Seitzinger	
5,383,904	A	1/1995	Totakura et al.	
2005/0043580	A1	2/2005	Watschke et al.	
2005/0203344	A1	9/2005	Orban, III et al.	
2005/0216040	A1*	9/2005	Gertner et al.	606/151
2005/0250980	A1	11/2005	Swanstrom et al.	
2009/0137862	A1	5/2009	Evans et al.	
2010/0081864	A1*	4/2010	Hess et al.	600/37

FOREIGN PATENT DOCUMENTS

WO WO 2007/149555 12/2007

OTHER PUBLICATIONS

Sakaguchi Y, Ikeda O, Toh Y, Aoki Y, Harimoto N, Taomoto J, Masuda T, Ohga T, Adachi E, Okamura T. New technique for the retraction of the liver in laparoscopic gastroectomy. *Surgical Endoscopy* 22; 2532-2534, 2008)*

* cited by examiner

Primary Examiner — Charles A Marmor, II

Assistant Examiner — Catherine E Burk

(74) *Attorney, Agent, or Firm* — Joseph M. Rolnicki; Evans & Dixon, LLC

(57) **ABSTRACT**

An apparatus including a flexible length of cord and three tissue connectors positioned at the opposite ends of the cord and at an intermediate position of the cord is designed to be laparoscopically inserted through the abdominal wall and into the abdominal cavity, and used to move a first internal organ to a position away from a second internal organ where the apparatus holds the first internal organ in the position without further manual input, thereby providing surgical access to the second internal organ.

8 Claims, 36 Drawing Sheets

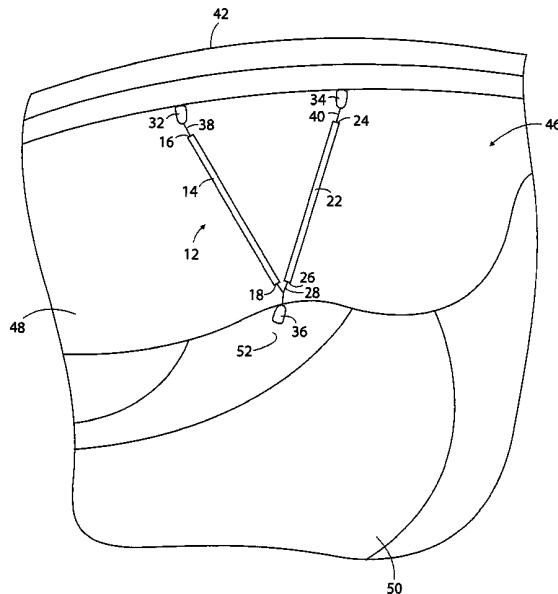

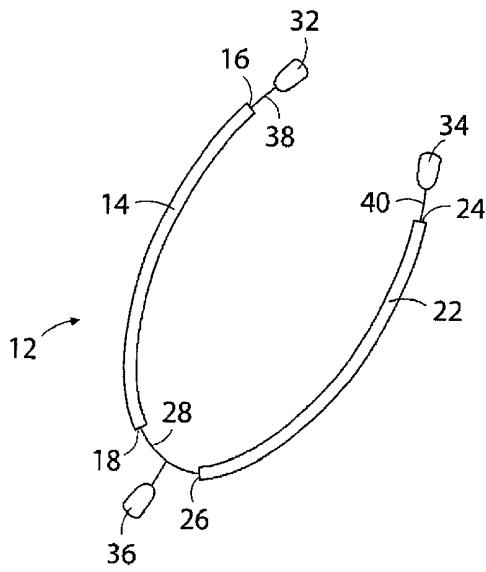

FIG. 1

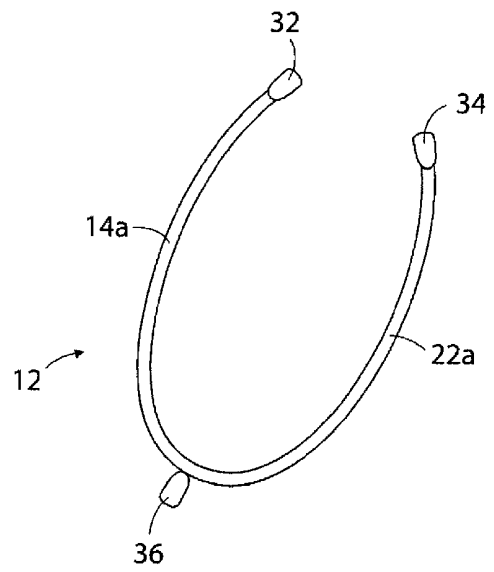

FIG. 2

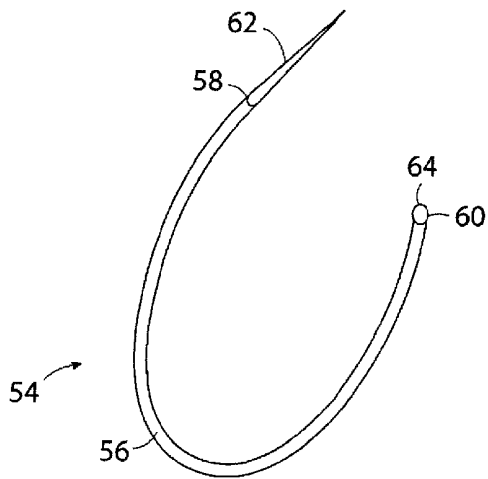

FIG. 3

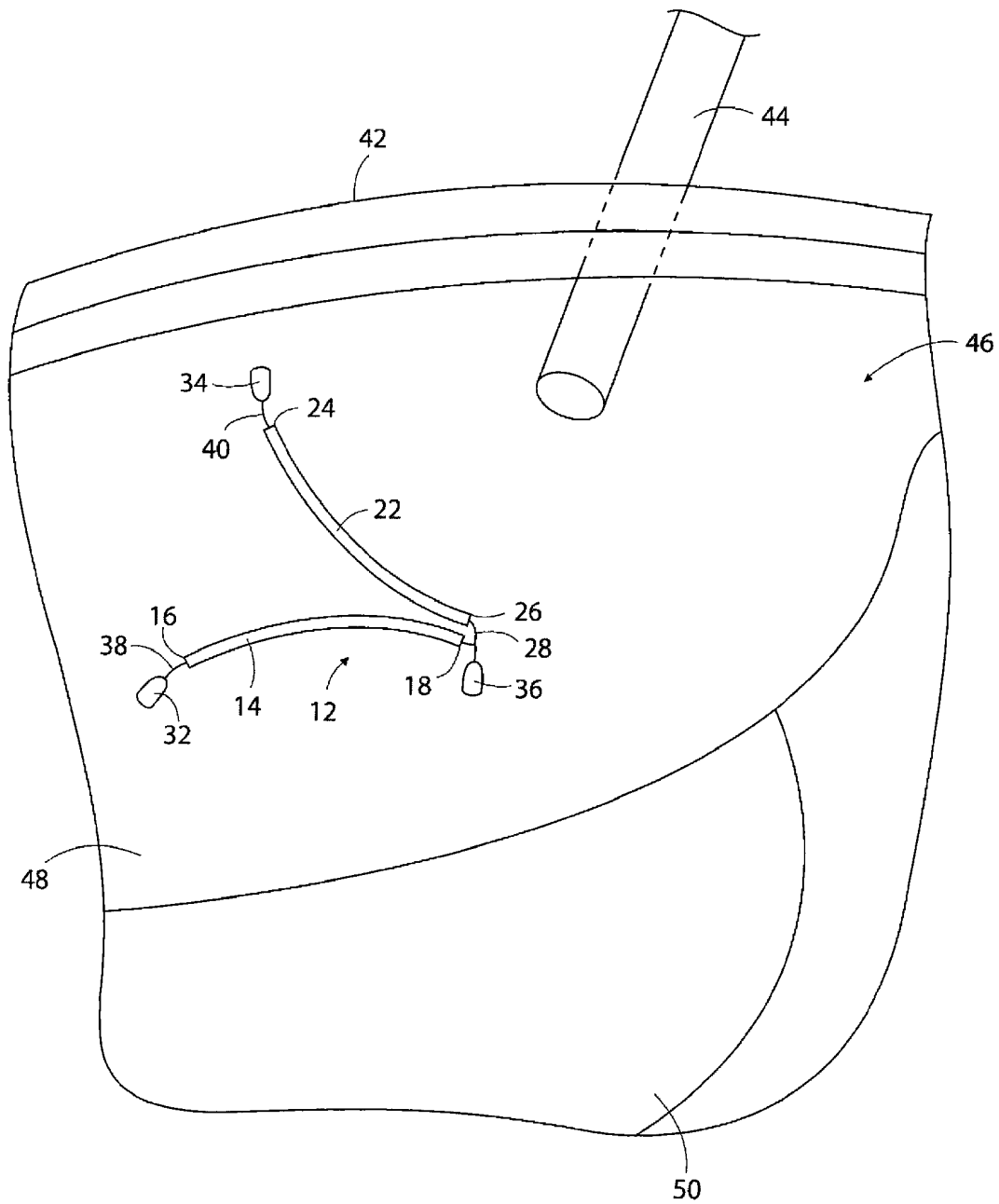

FIG. 4

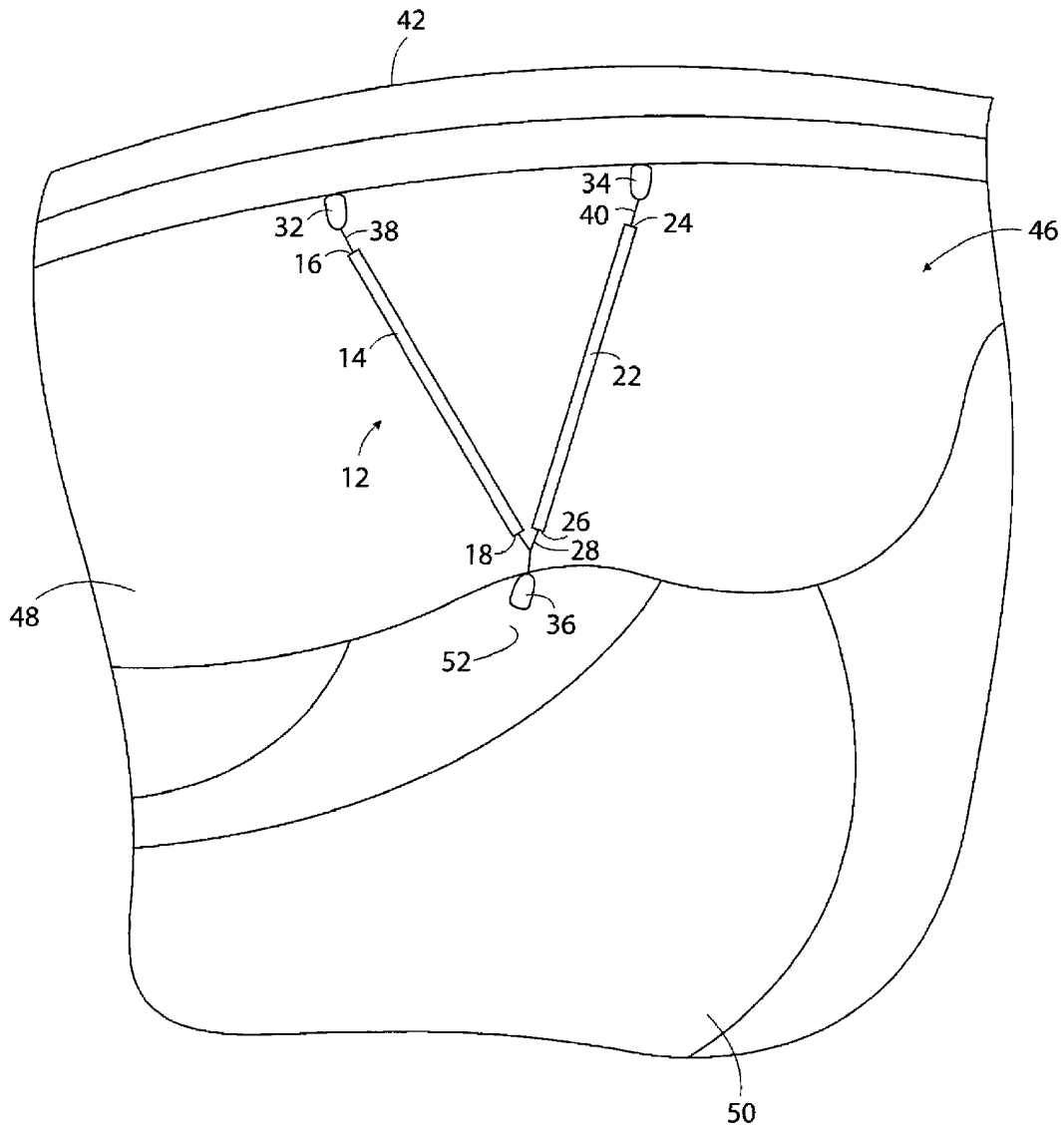

FIG. 5

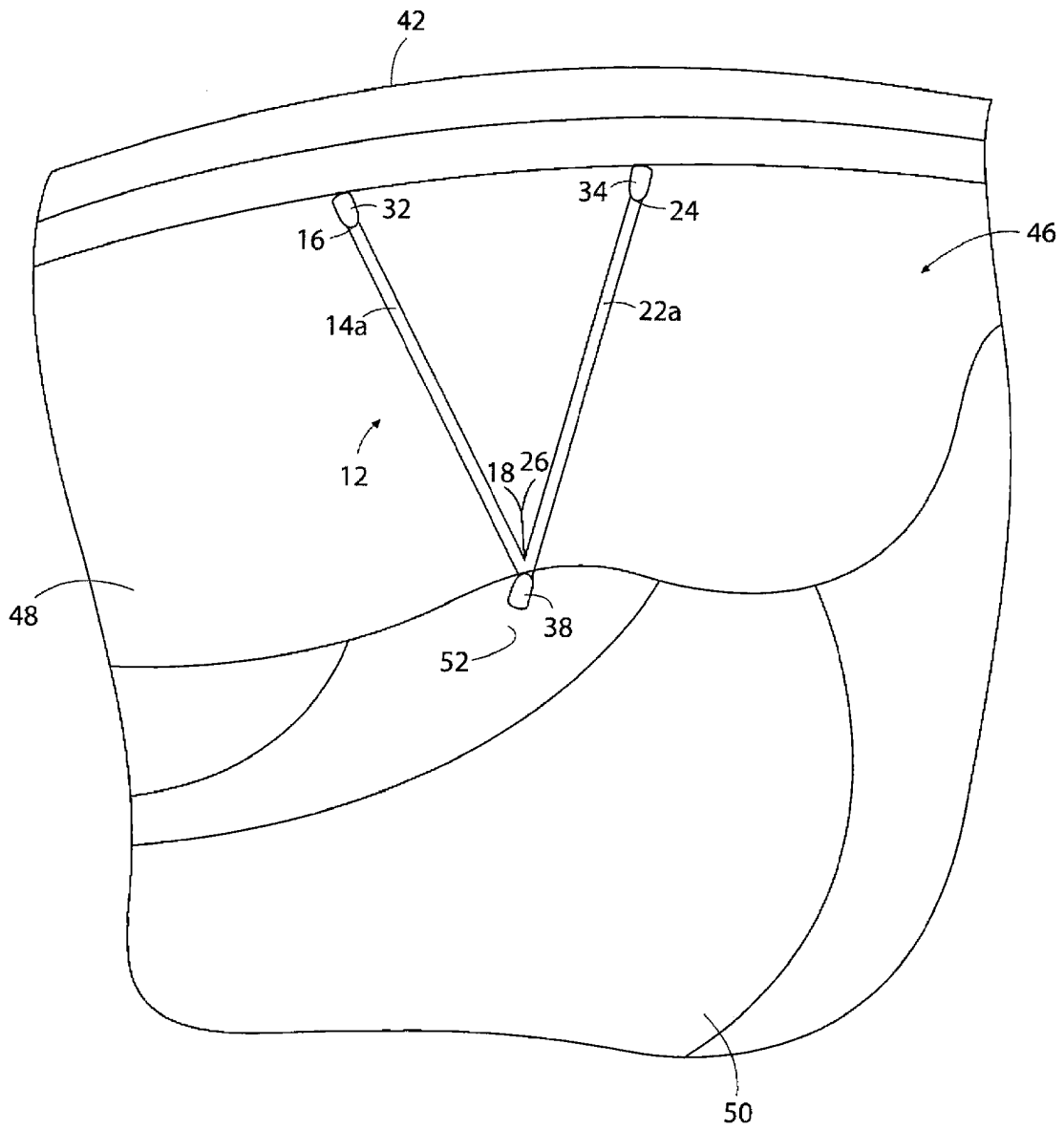

FIG. 6

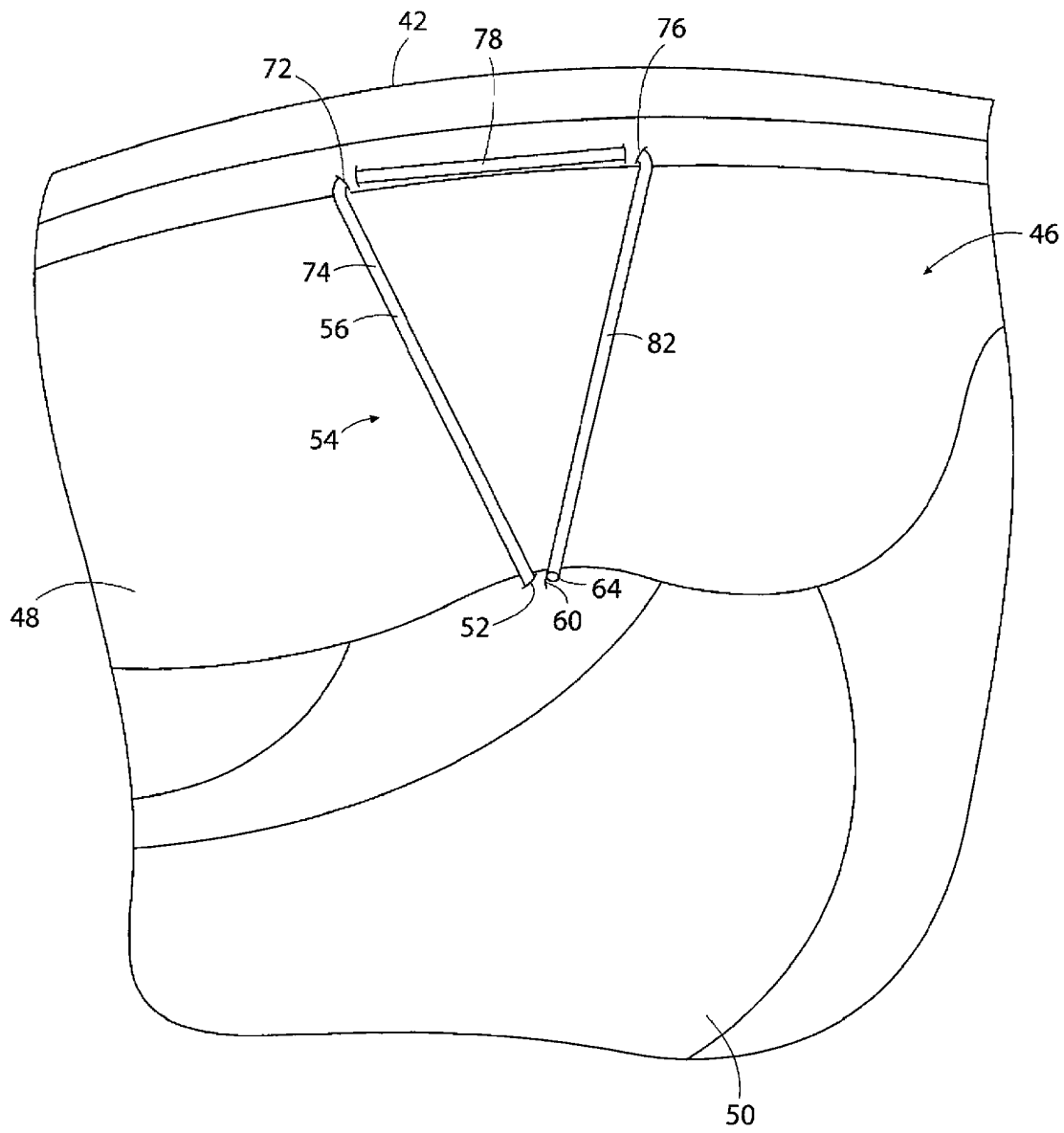
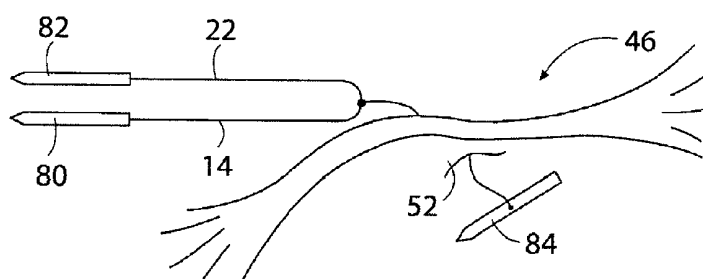
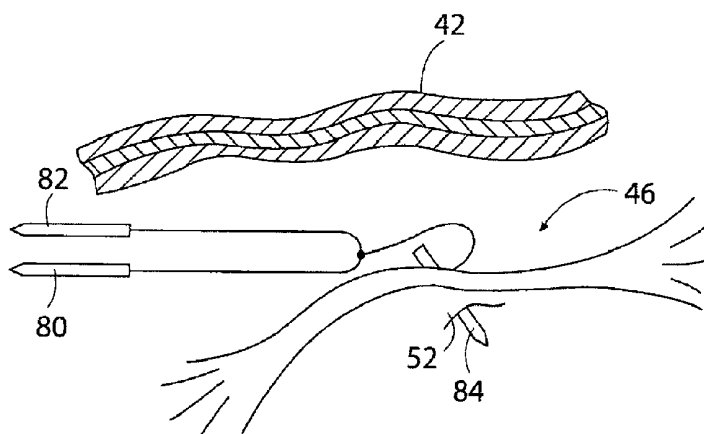
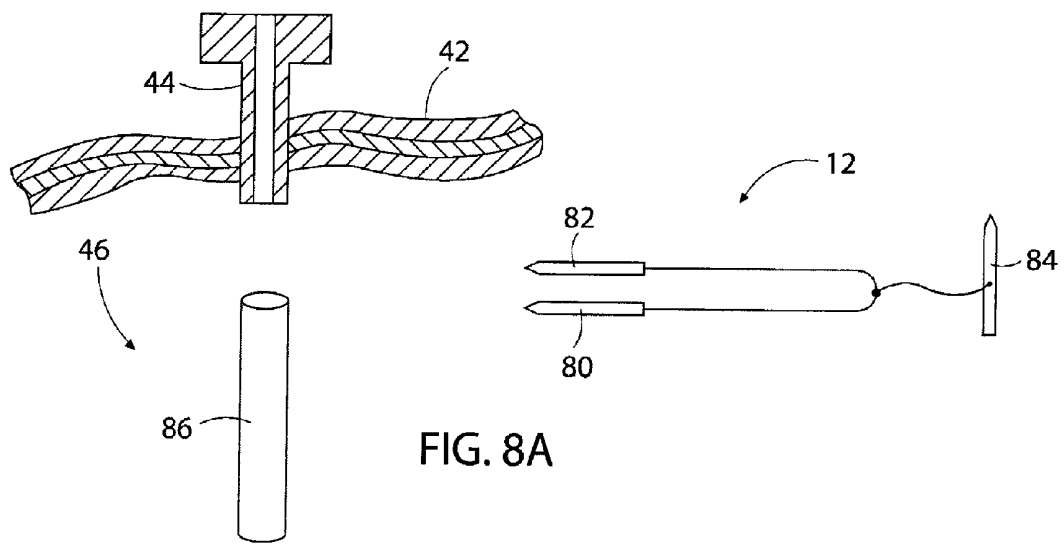

FIG. 7



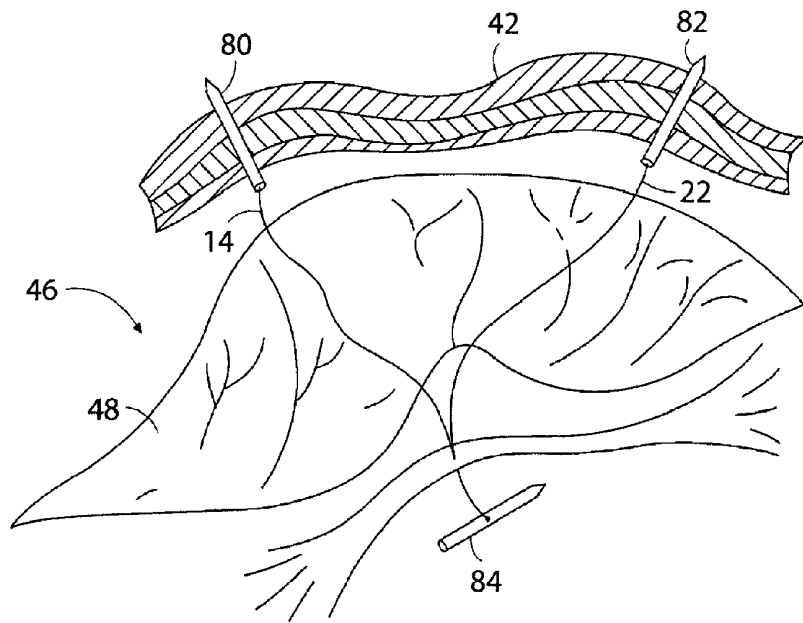

FIG. 8D

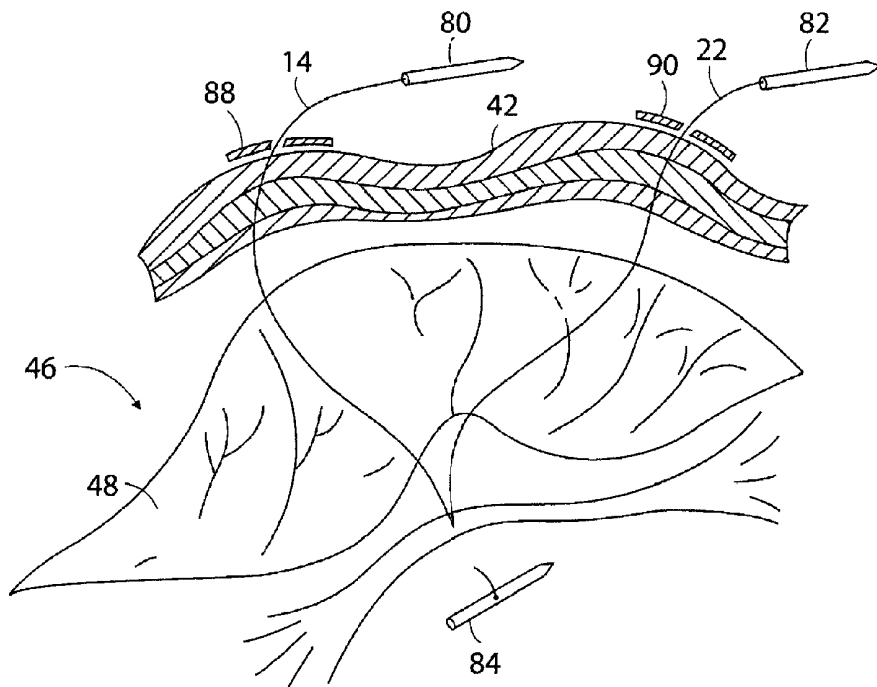
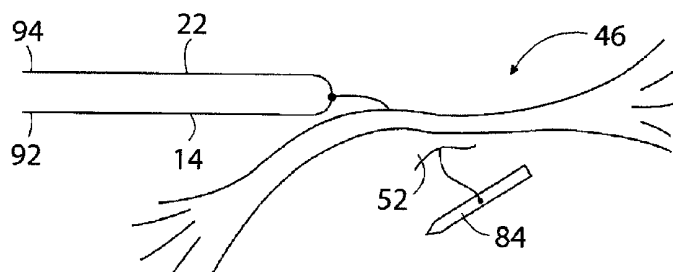
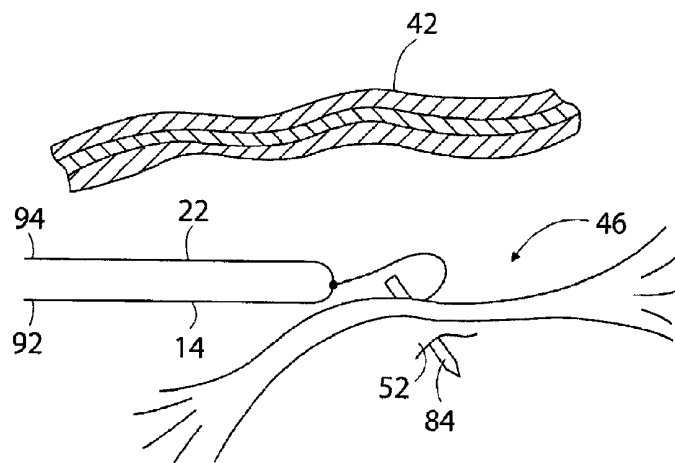
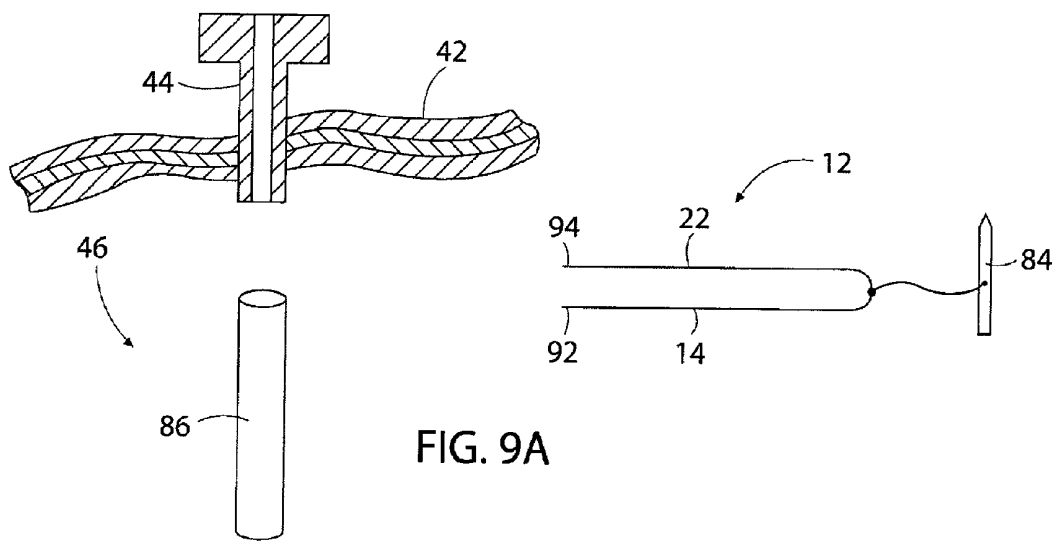

FIG. 8E



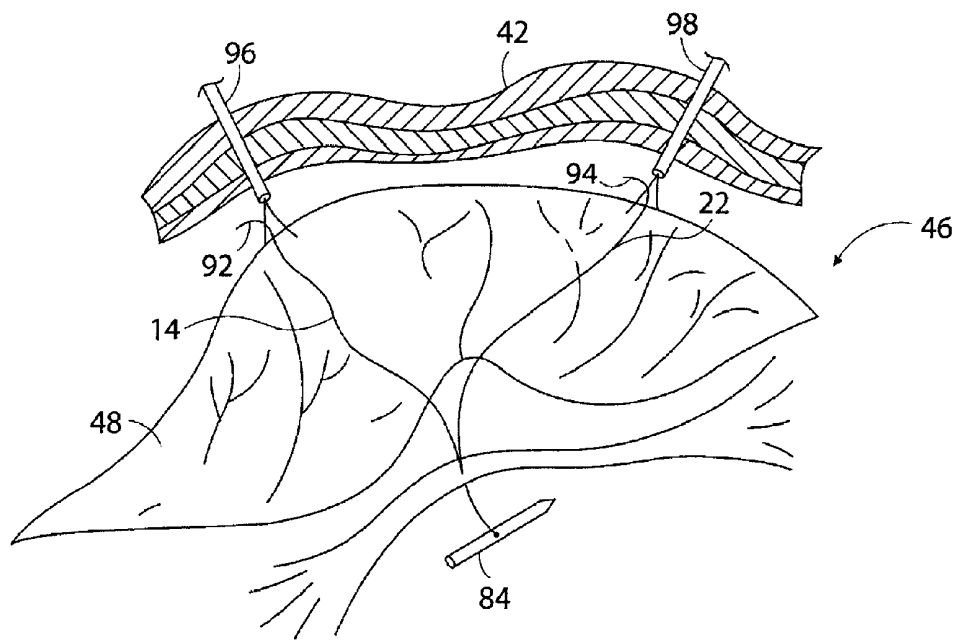

FIG. 9D

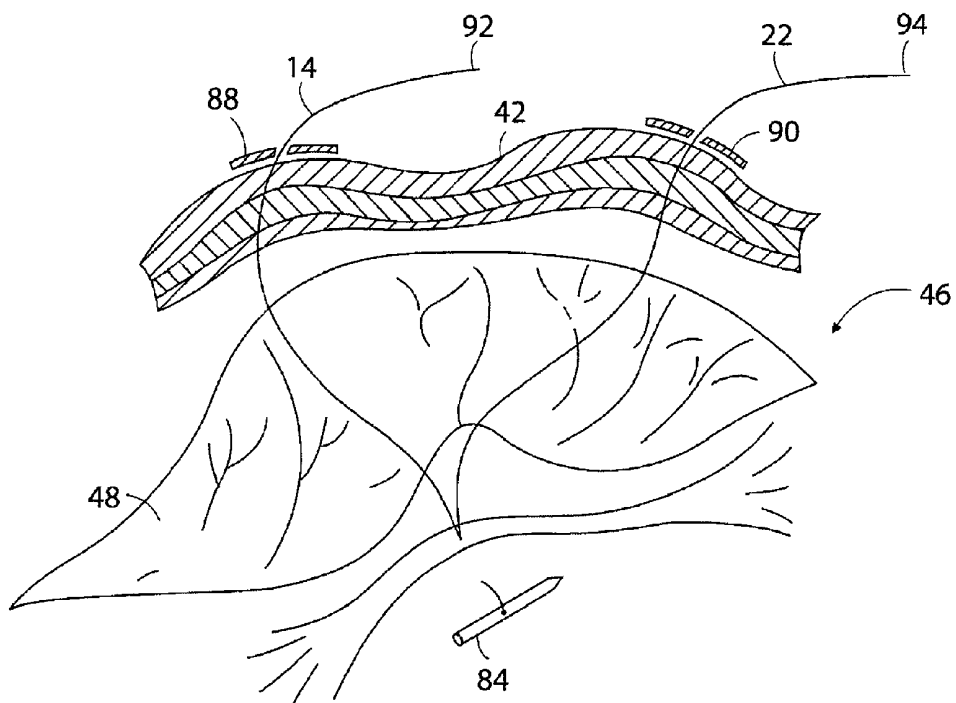

FIG. 9E

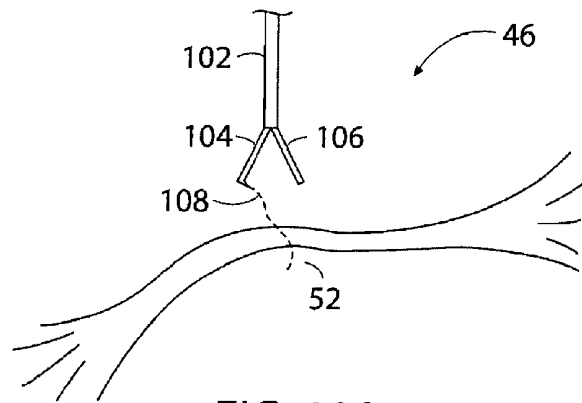
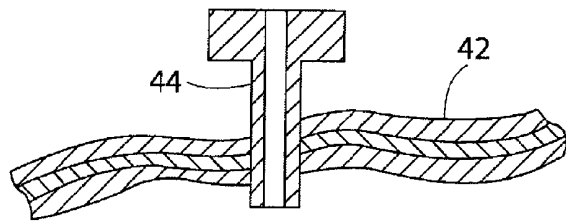

FIG. 10A

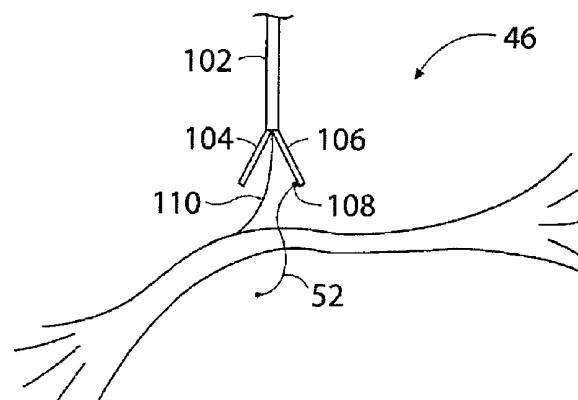
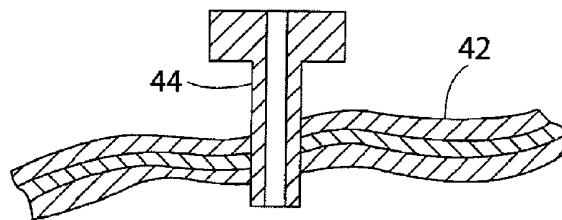

FIG. 10B

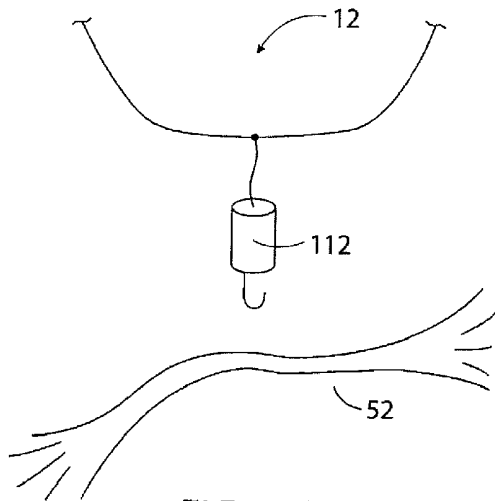

FIG. 11A

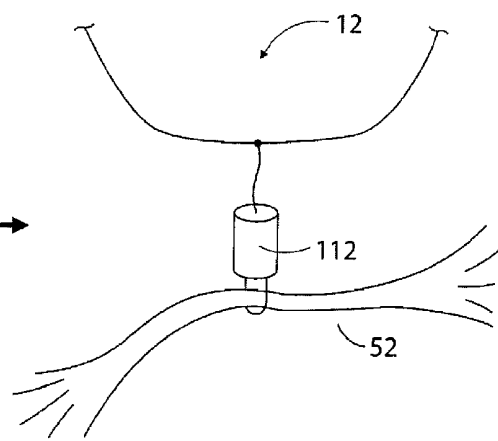

FIG. 11B

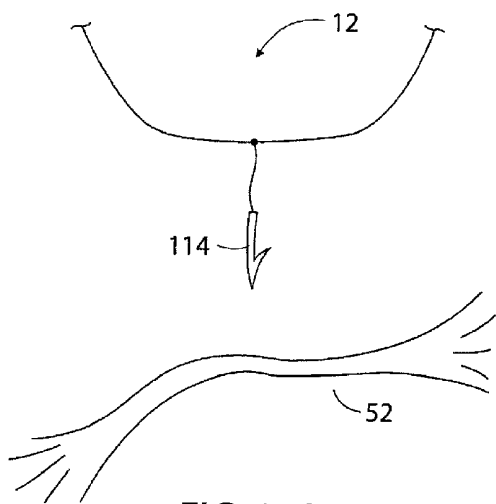

FIG. 12A

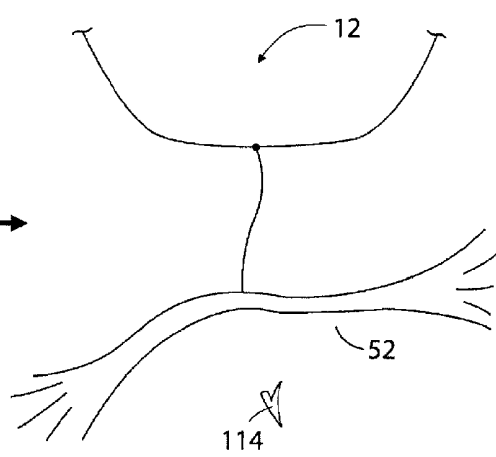

FIG. 12B

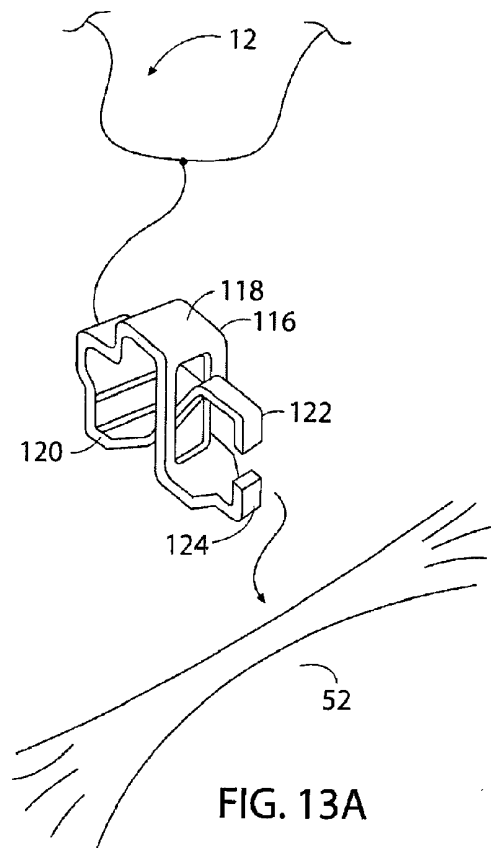

FIG. 13A

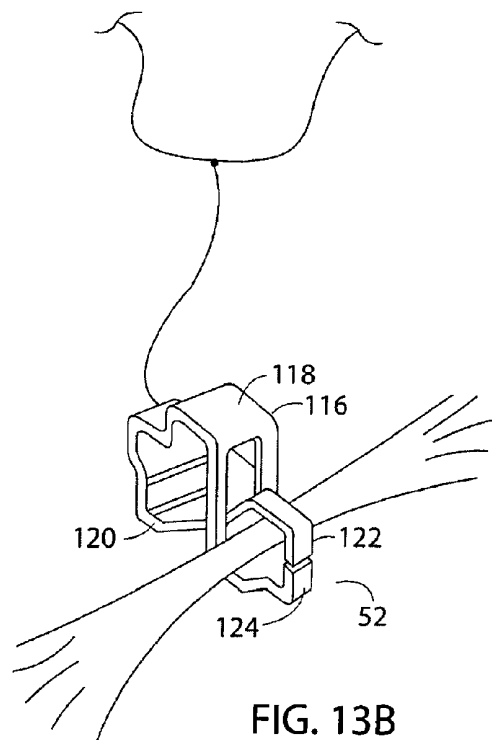
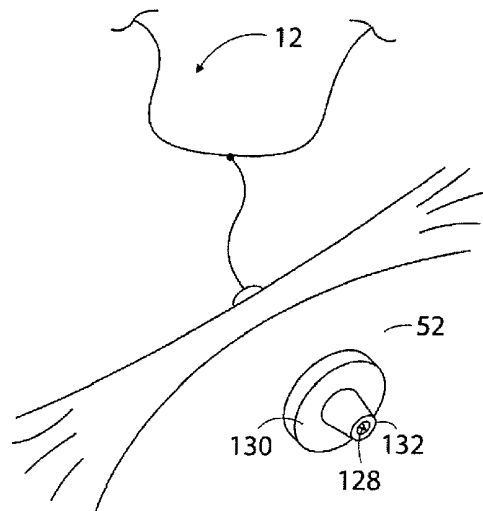
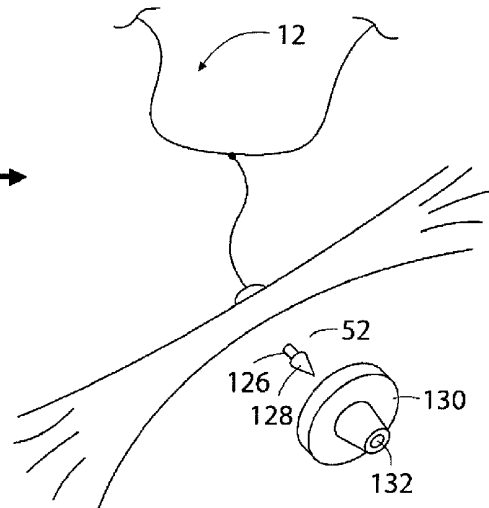
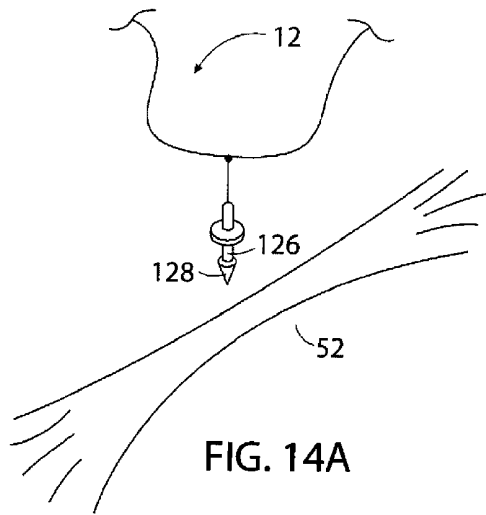

FIG. 13B



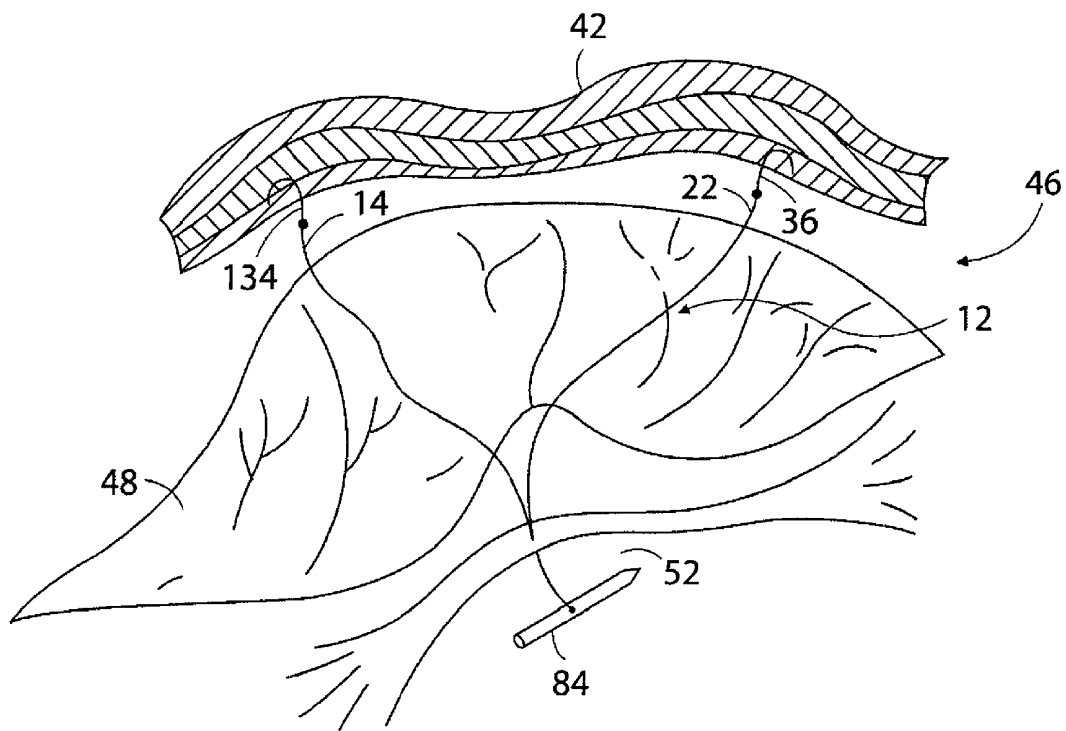

FIG. 15B

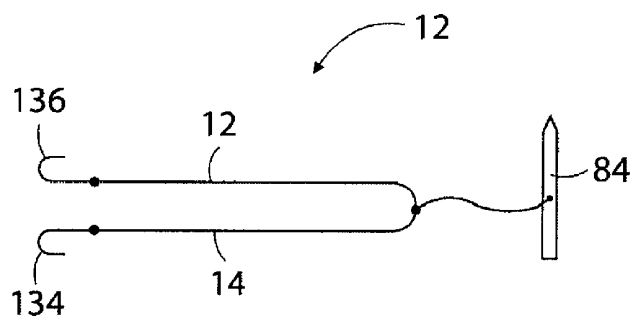

FIG. 15A

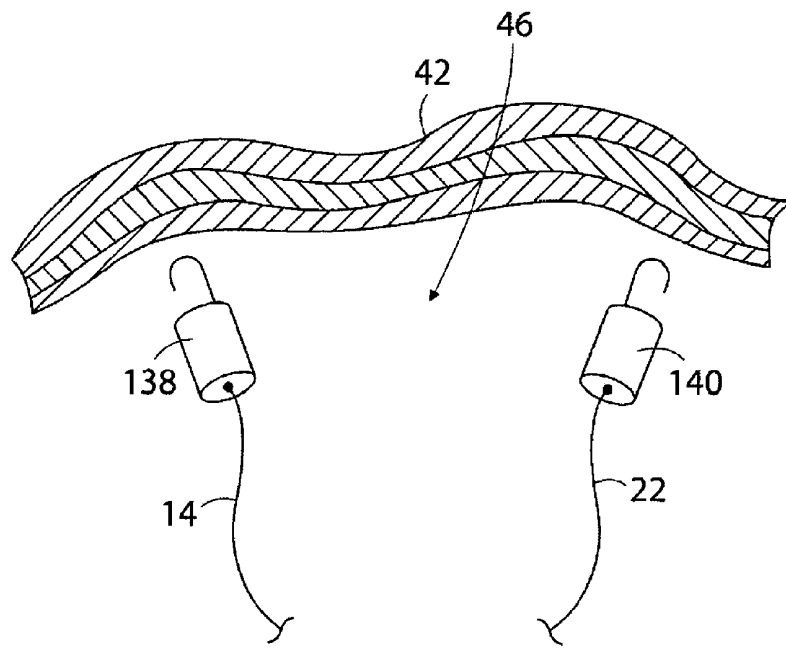

FIG. 16A

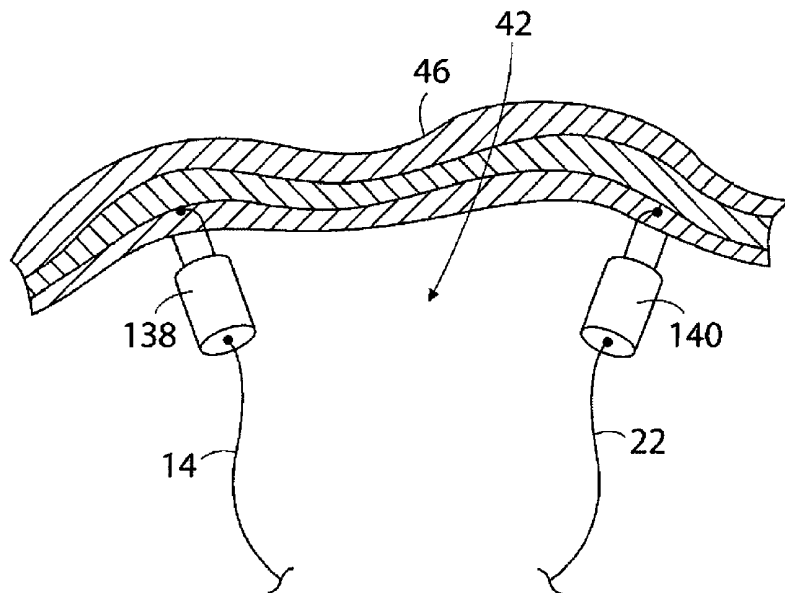

FIG. 16B

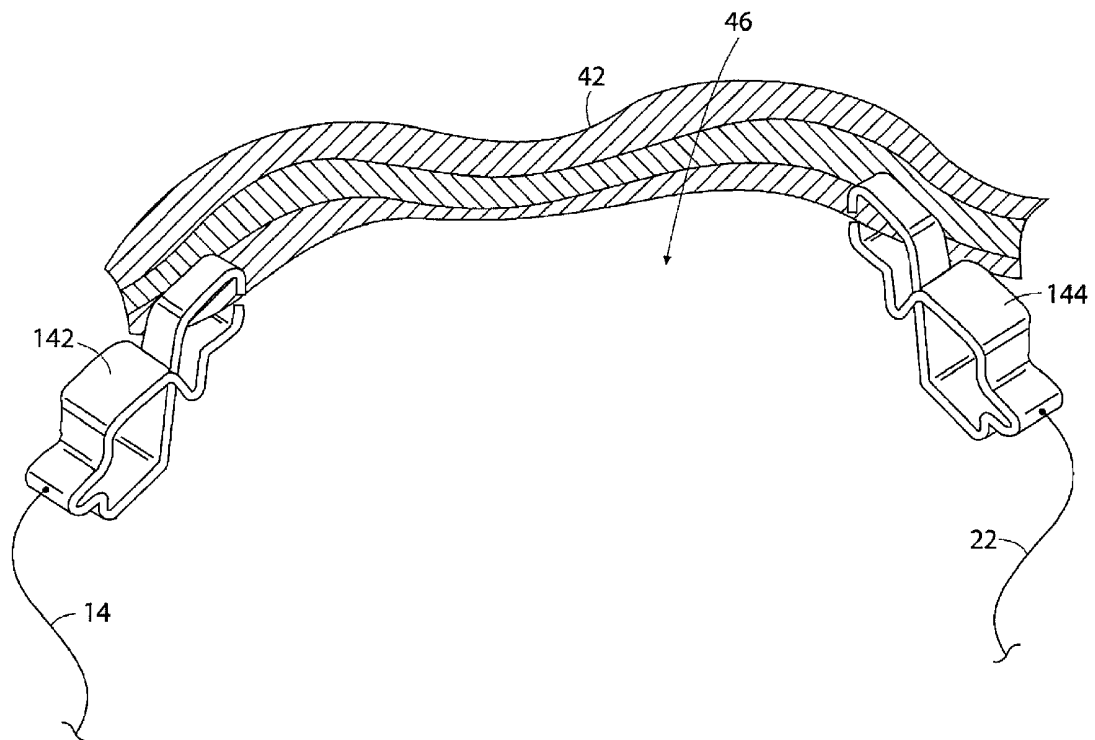

FIG. 17

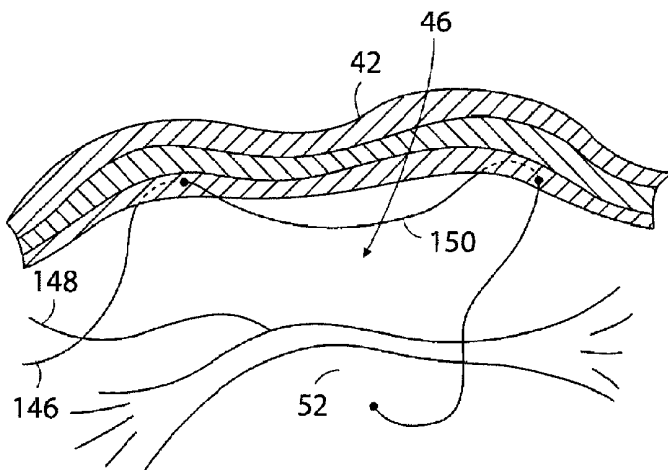

FIG. 18A

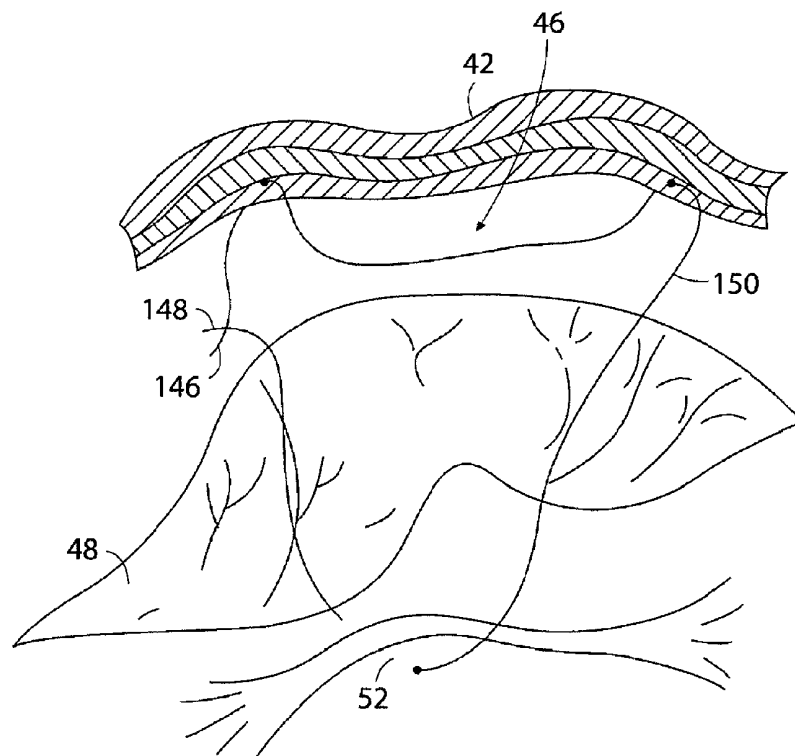

FIG. 18B

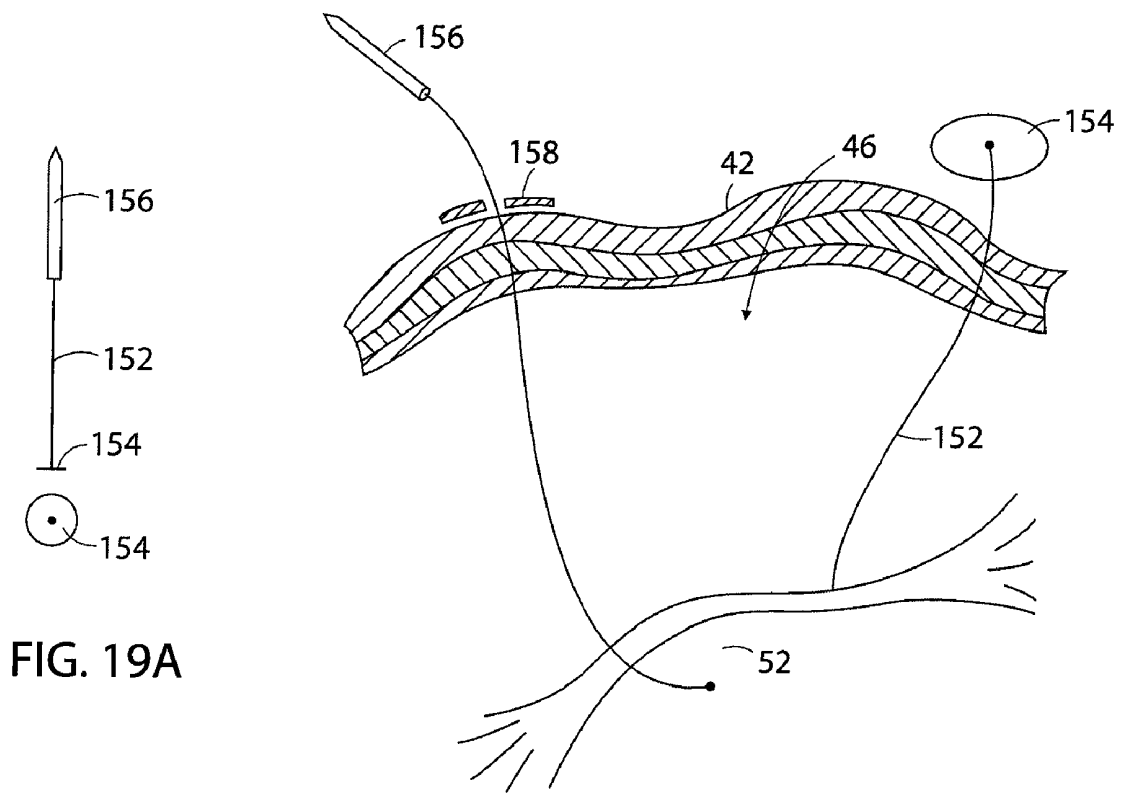

FIG. 19A

FIG. 19B

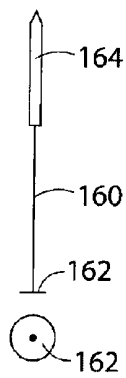

FIG. 20A

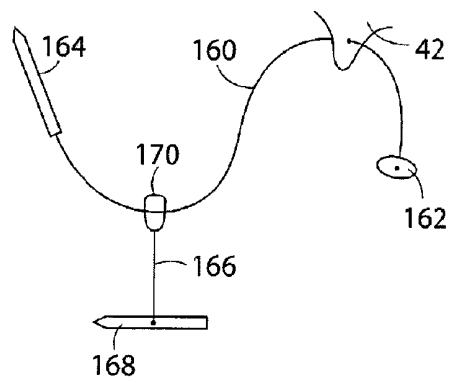
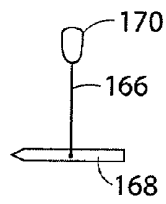

FIG. 20B

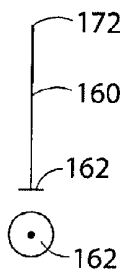

FIG. 21A

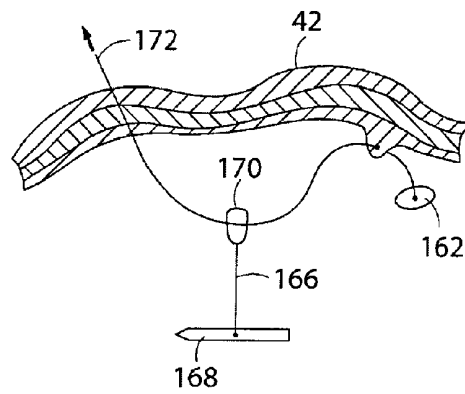
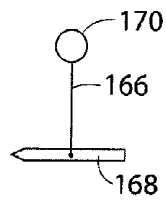

FIG. 21B

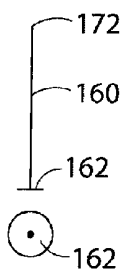

FIG. 22A

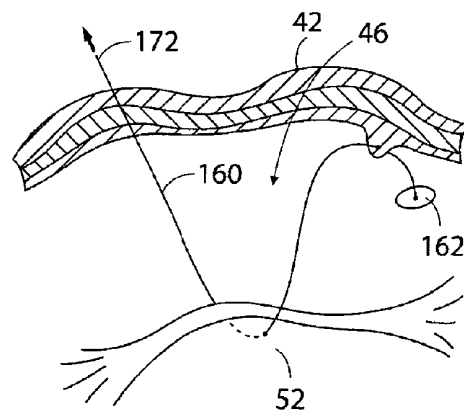

FIG. 22B

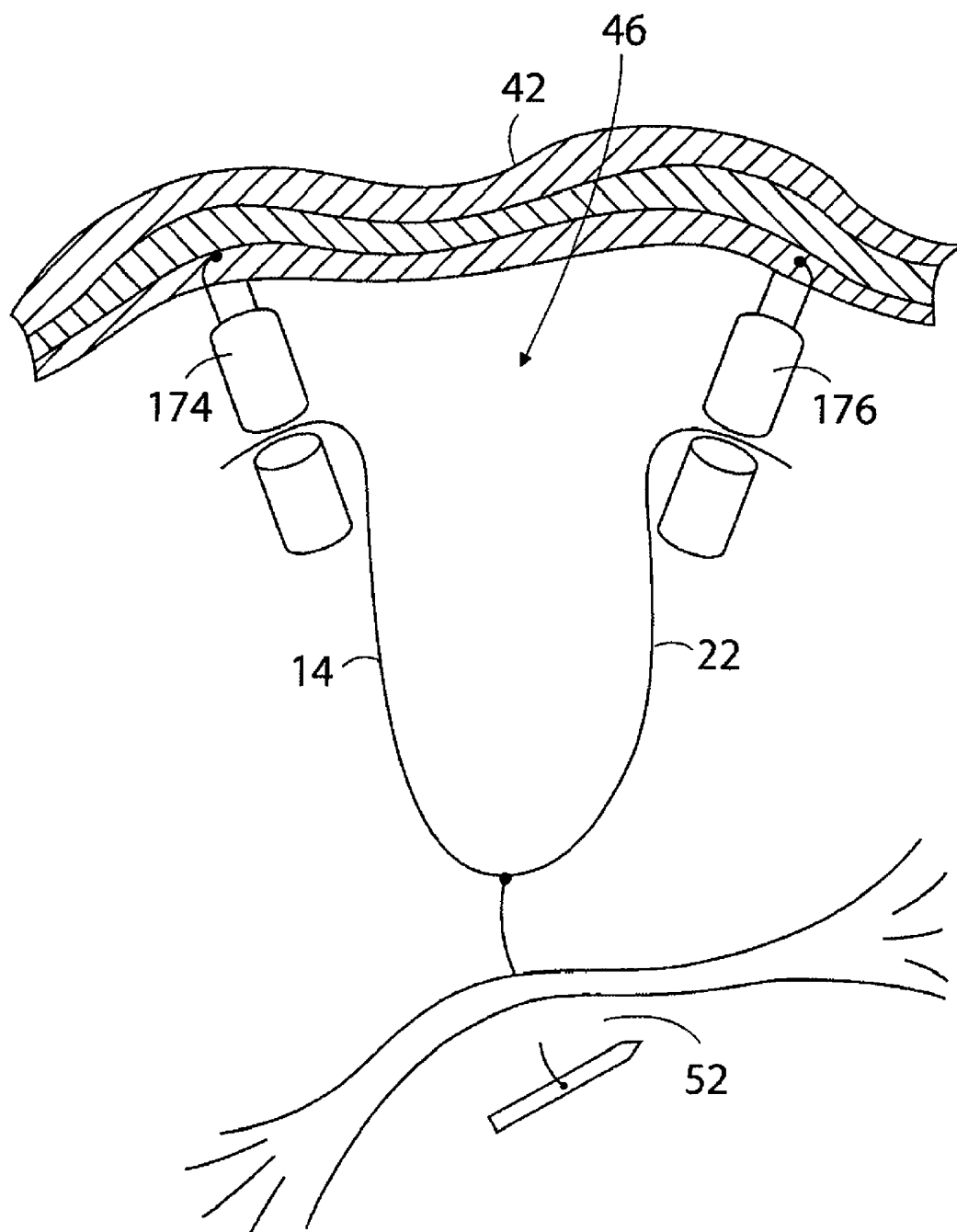

FIG. 23

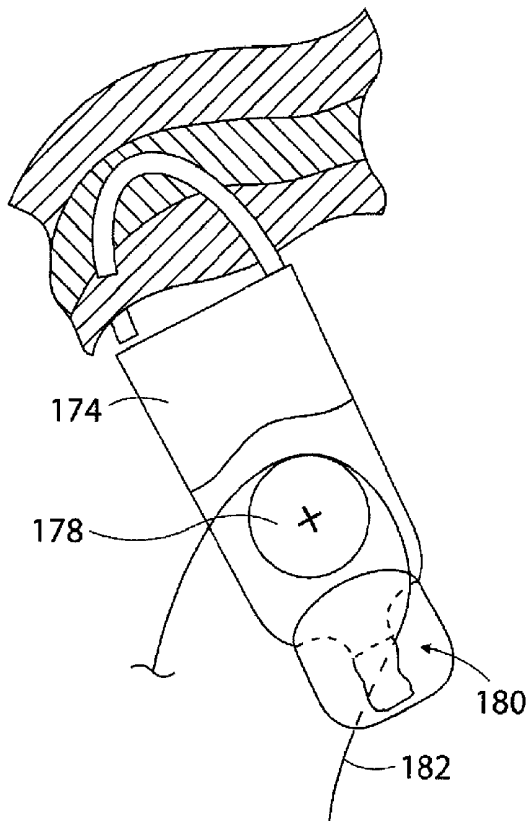

FIG. 24A

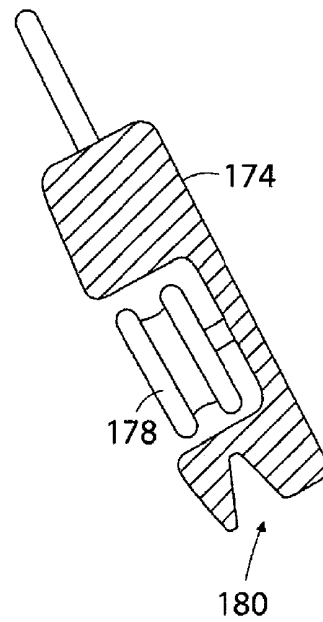

FIG. 24B

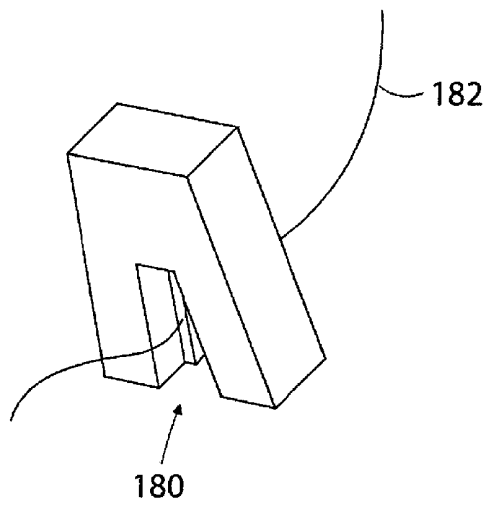

FIG. 24C

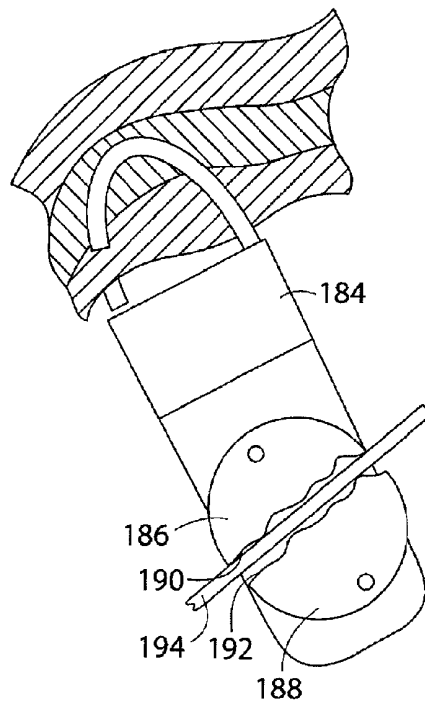

FIG. 25

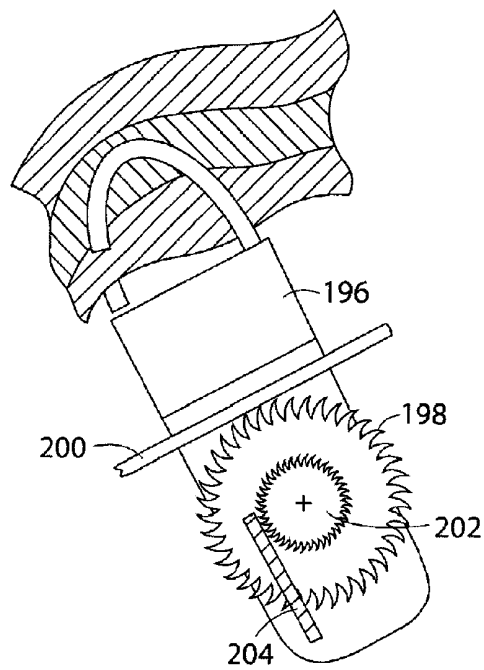

FIG. 26

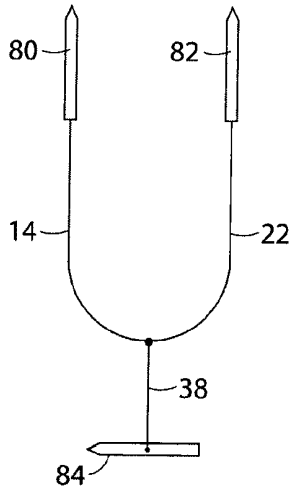

FIG. 27

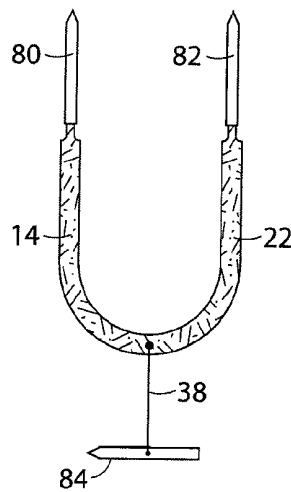

FIG. 28

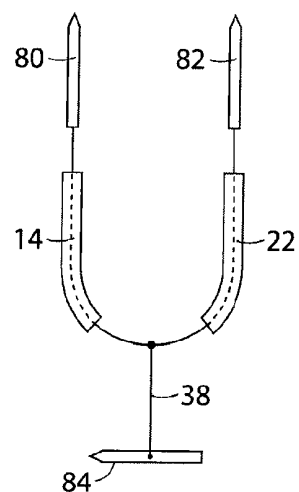

FIG. 29

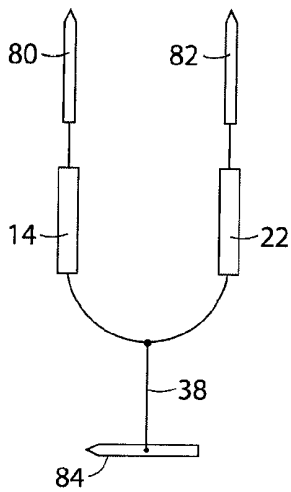

FIG. 30

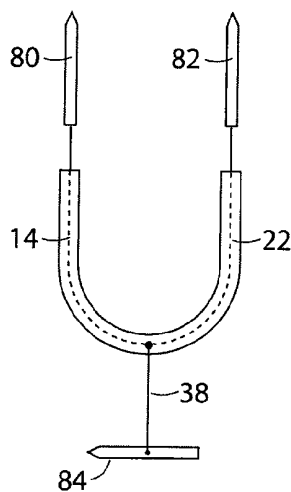

FIG. 31

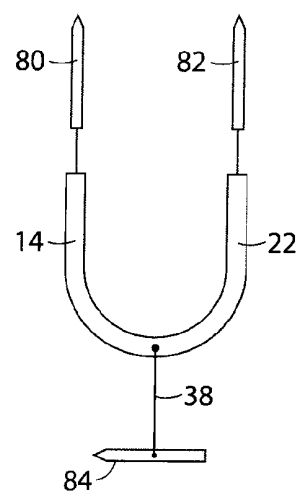

FIG. 32

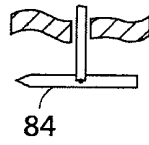

FIG. 33

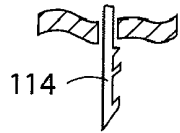

FIG. 34

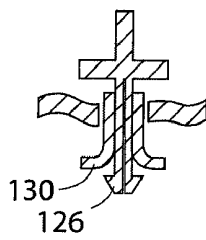

FIG. 35

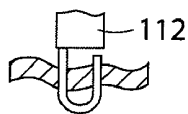

FIG. 36

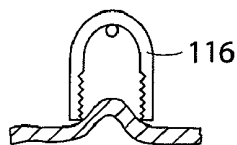

FIG. 37

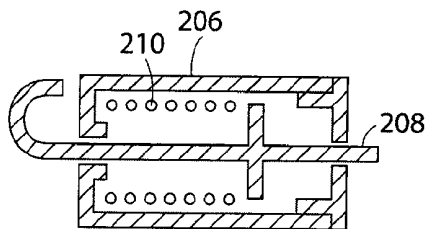

FIG. 38

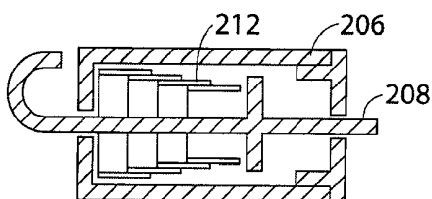

FIG. 39A

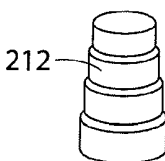

FIG. 39B



FIG. 39C

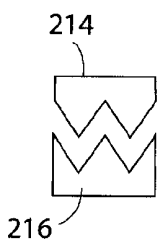

FIG. 40B

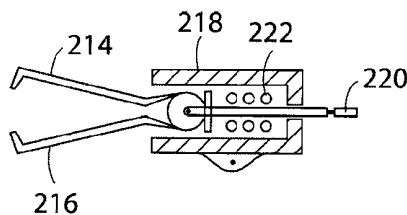

FIG. 40A

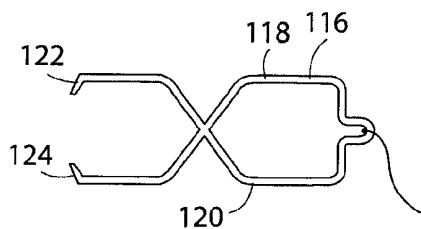

FIG. 41

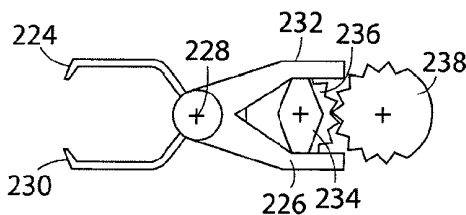

FIG. 42

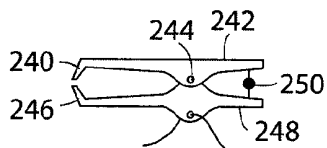

FIG. 43

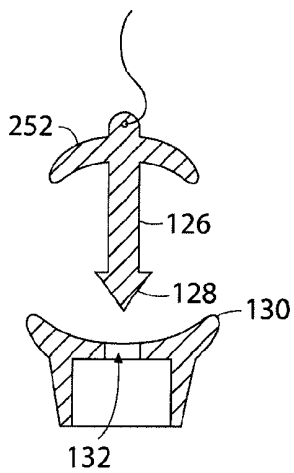

FIG. 44A

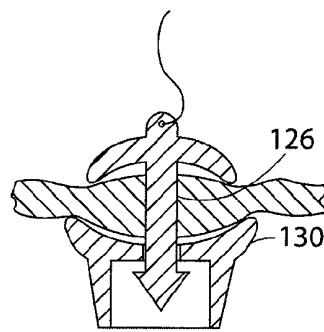

FIG. 44B

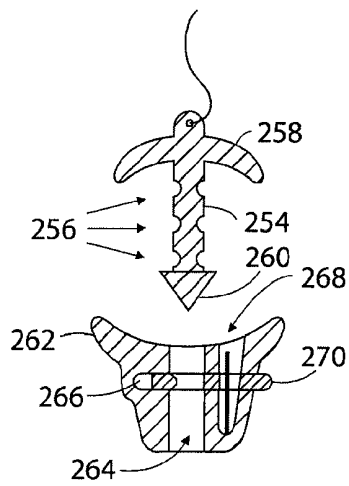

FIG. 45A

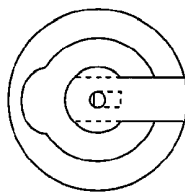

FIG. 45B

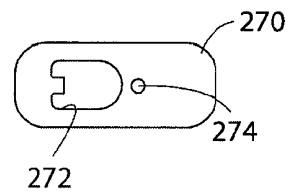

FIG. 45C

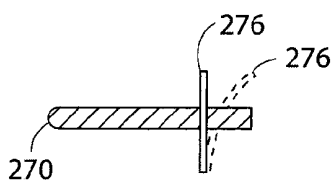

FIG. 45D

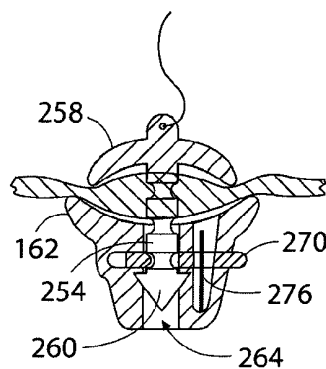

FIG. 45E

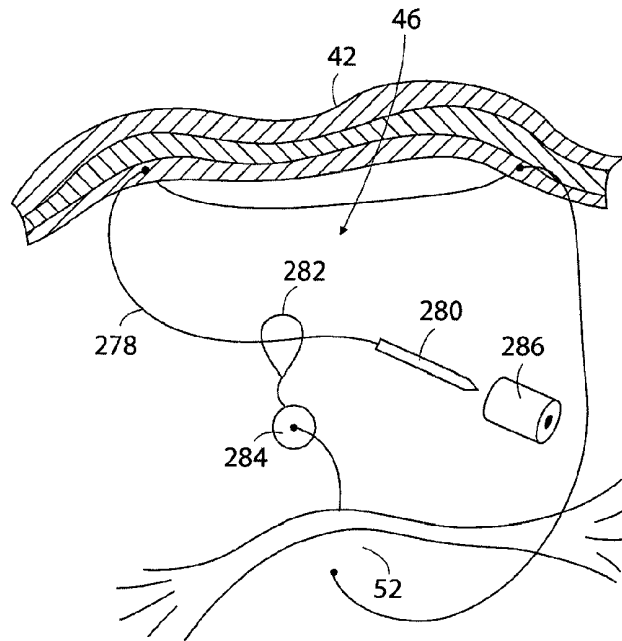
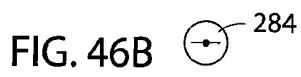
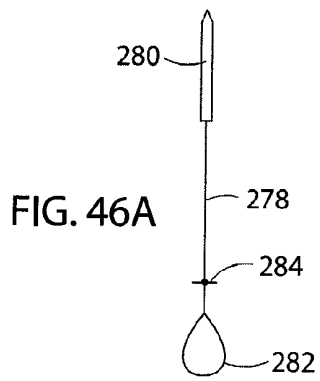

FIG. 46C

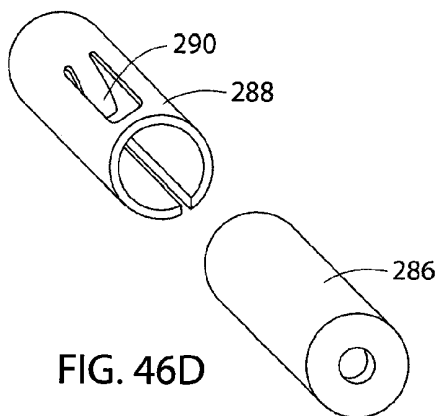

FIG. 46D

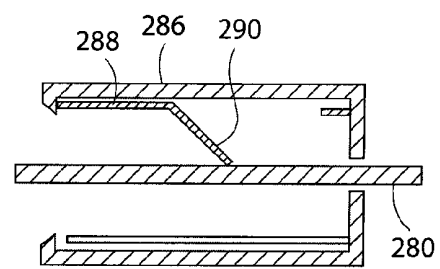

FIG. 46E

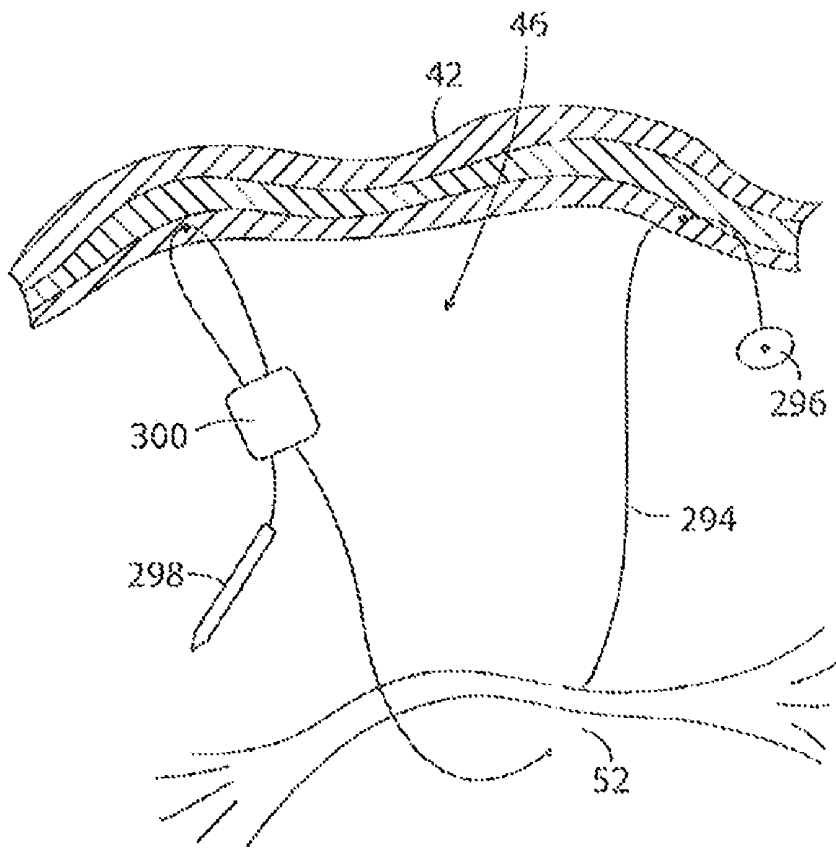

FIG. 47A

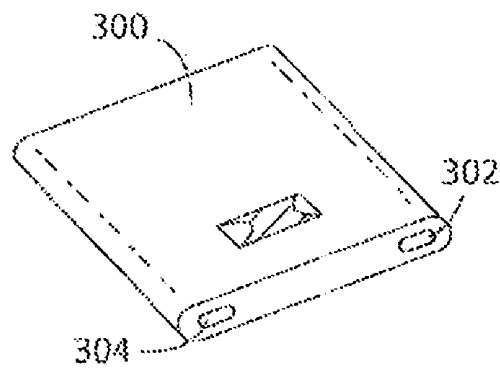
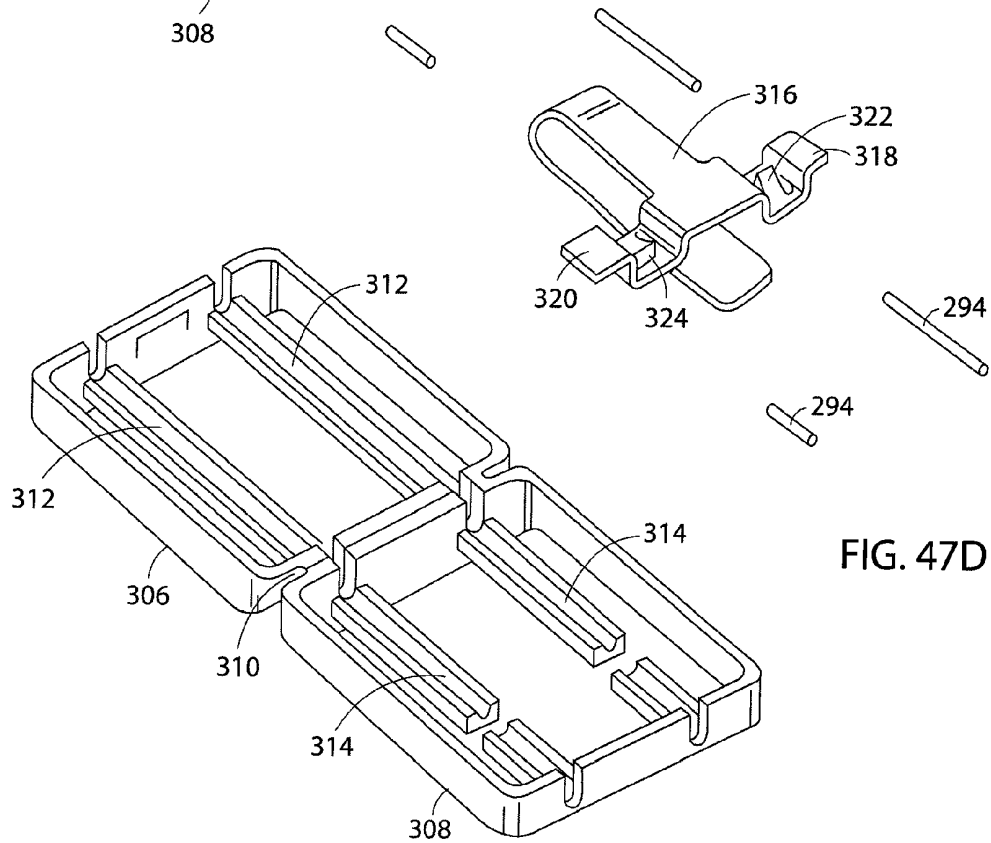
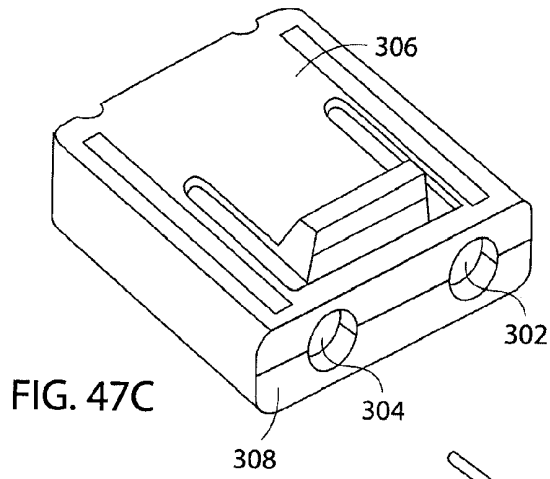

FIG. 47B



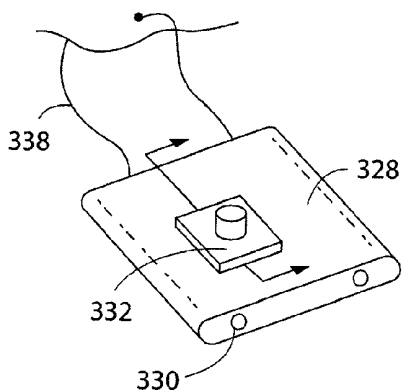

FIG. 48A

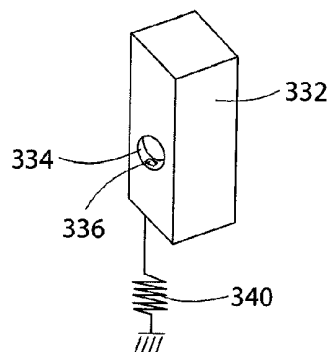

FIG. 48B

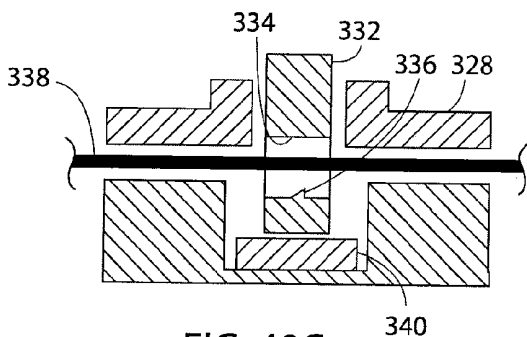

FIG. 48C

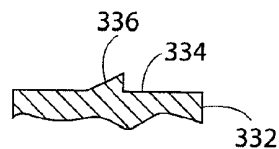

FIG. 48D

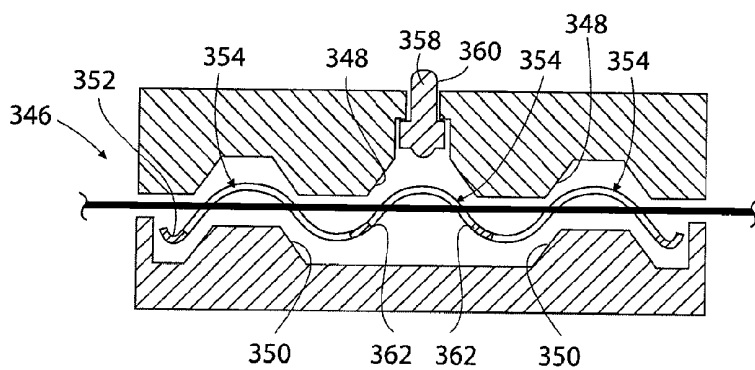

FIG. 49A

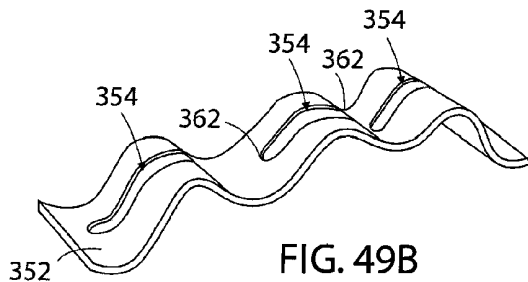
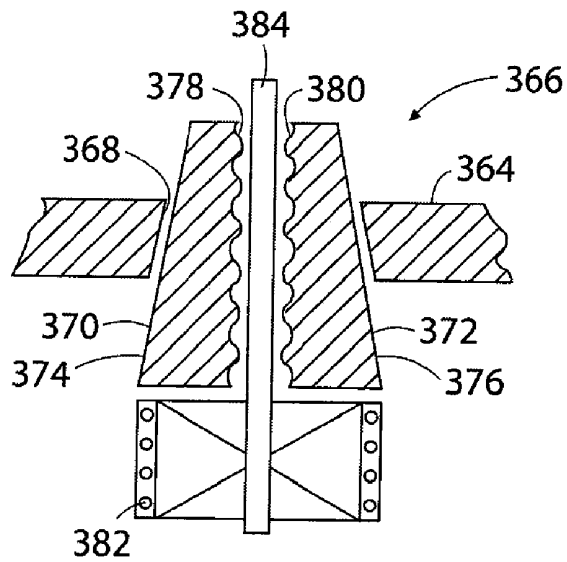
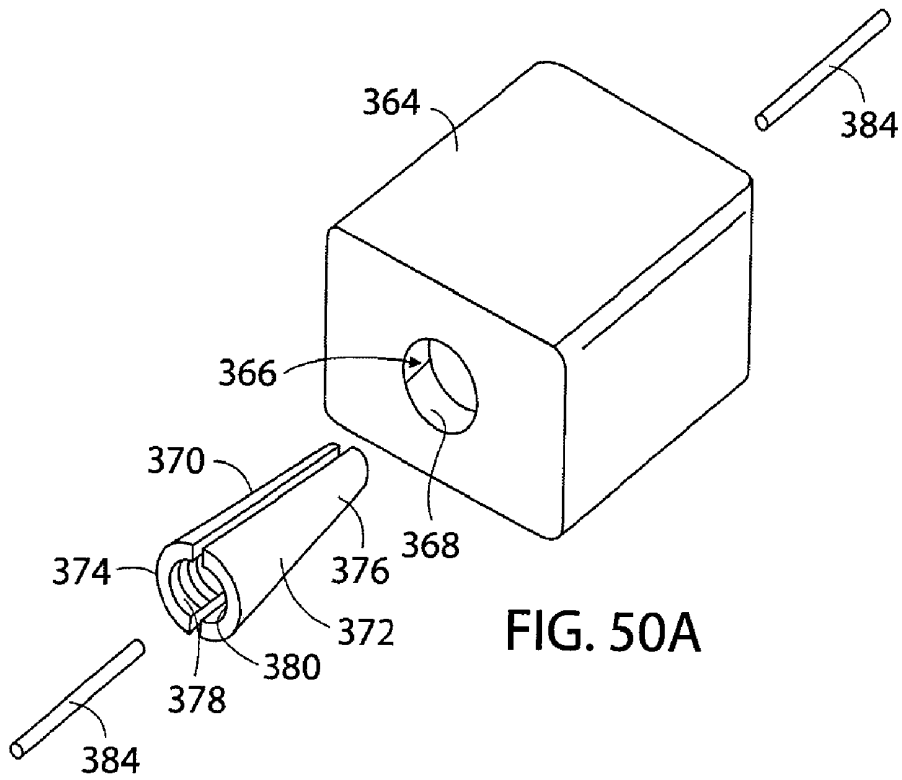

FIG. 49B



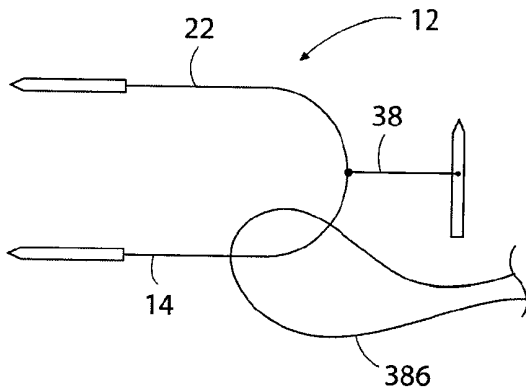

FIG. 51A

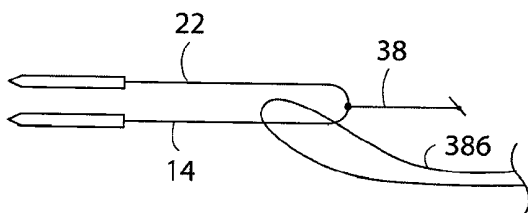

FIG. 51B

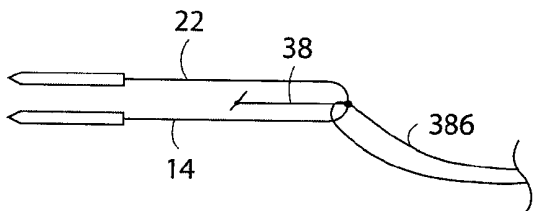

FIG. 51C

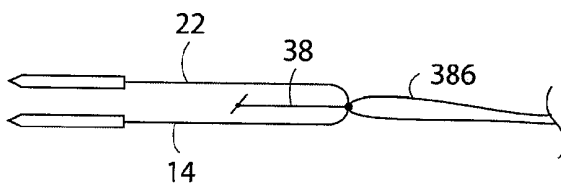

FIG. 51D

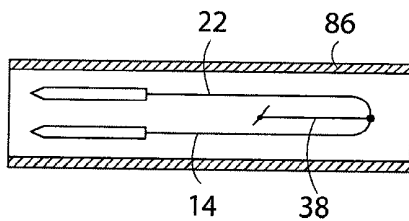

FIG. 51E

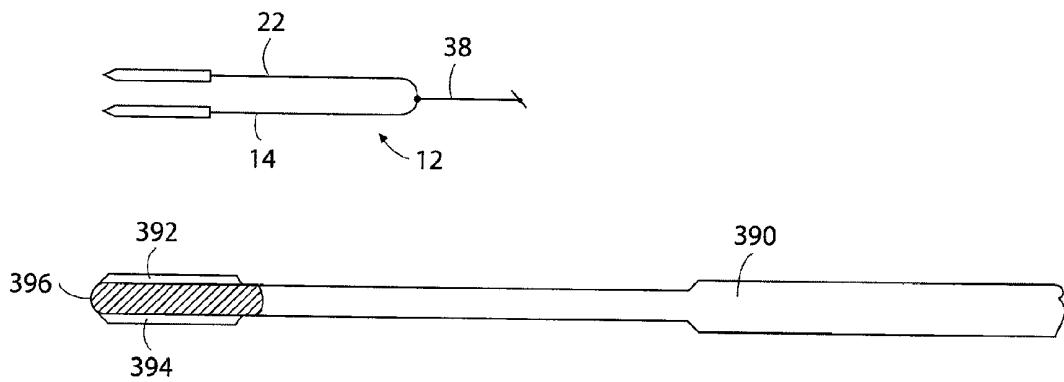

FIG. 52A

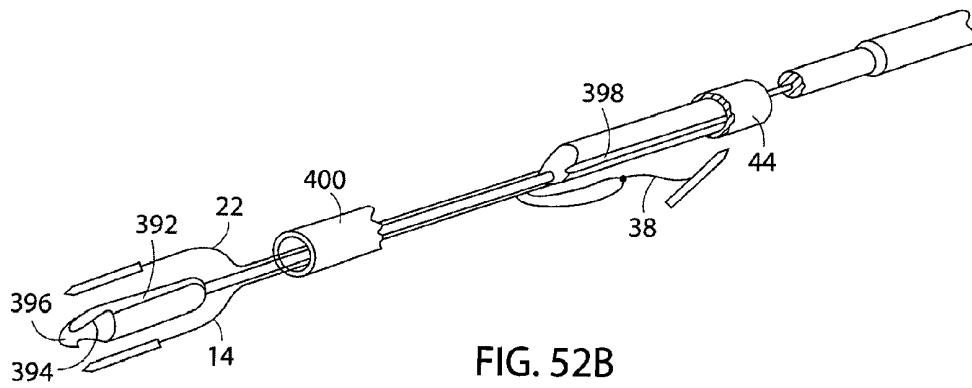

FIG. 52B

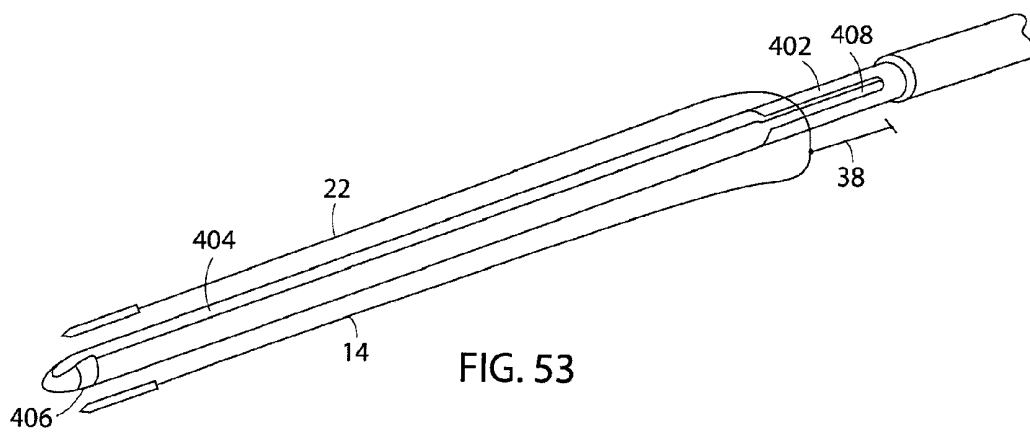

FIG. 53

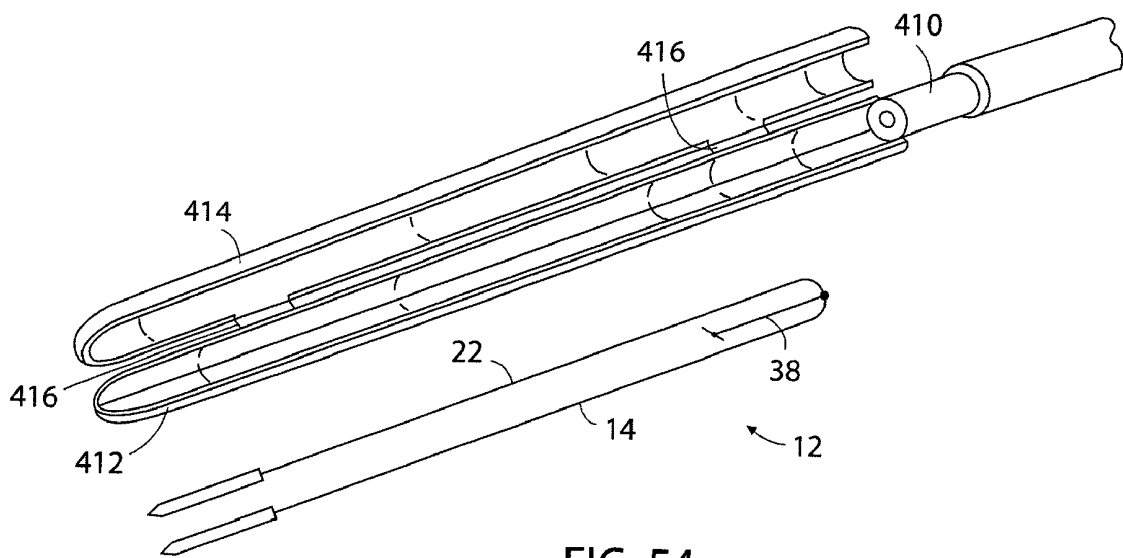

FIG. 54

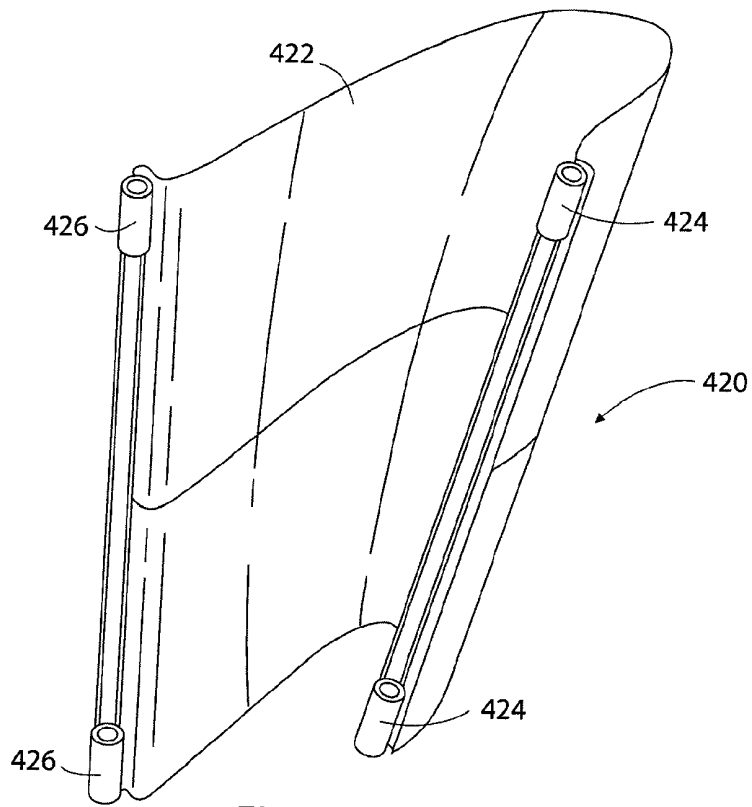

FIG. 55A

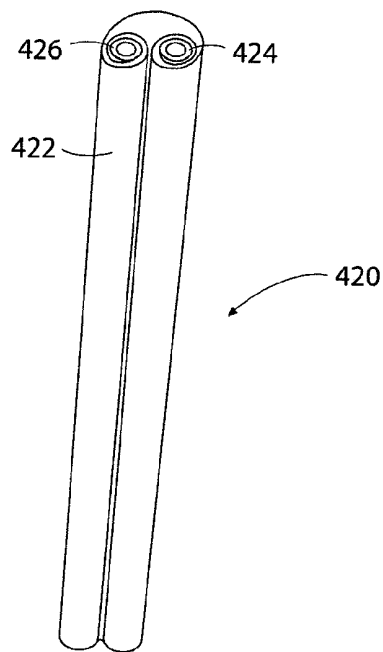
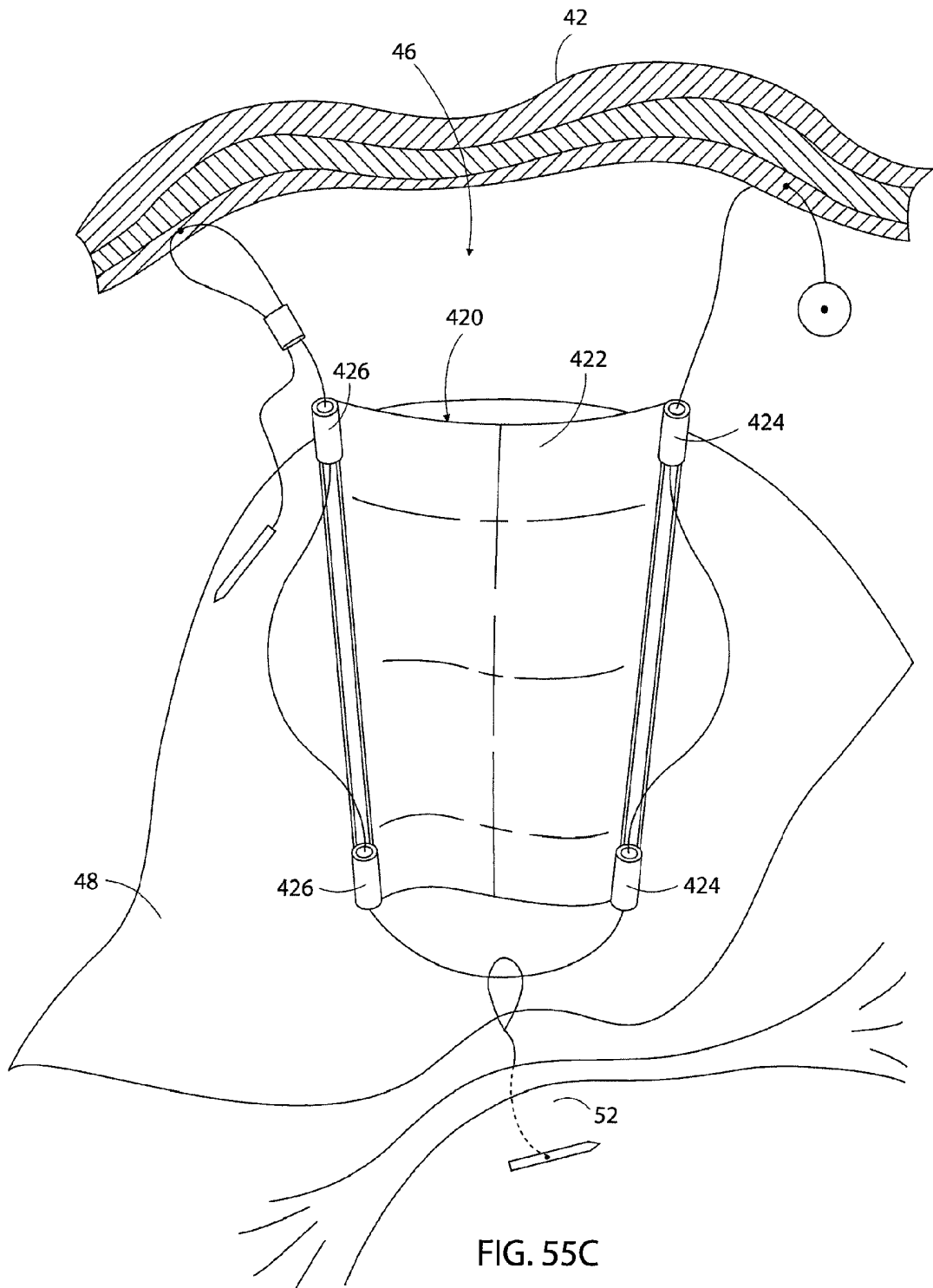

FIG. 55B



**APPARATUS AND METHOD FOR
INTRA-ABDOMINALLY MOVING A FIRST
INTERNAL ORGAN TO A POSITION AWAY
FROM A SECOND INTERNAL ORGAN AND
THEN HOLDING THE FIRST INTERNAL
ORGAN IN THE POSITION WITHOUT
MANUAL INPUT**

BACKGROUND OF THE INVENTION

1. Field of the Invention

The present invention is directed to an apparatus and its method of use in intra-abdominally moving a first internal organ to a position away from a second internal organ where the apparatus holds the first internal organ in the position without further manual input. More specifically, the present invention is directed to an apparatus that is inserted through the abdominal wall and into the abdominal cavity, and the method of using the apparatus in the abdominal cavity to move a human liver to a position away from a human stomach where the apparatus holds the liver in the position without further manual input, thereby providing surgical access to the stomach.

2. Description of the Related Art

In laparoscopic surgical procedures, it is often necessary to make incisions through the abdominal wall for the sole purpose of providing access to the abdominal cavity for surgical graspers or other similar types of retracting instruments that are used to move one internal organ to a position away from a second internal organ to gain surgical access to the second internal organ. The incisions made for the surgical graspers or similar retracting instruments are in addition to the incisions made in the abdominal wall for the surgical instruments used in performing the surgical procedure on the second organ.

Furthermore, it is often necessary that an additional surgeon or surgical assistant be present solely for the purpose of manipulating the surgical graspers or other similar retracting instruments in moving the first internal organ to a position away from the second internal organ, and then manually holding the first internal organ in the position during the surgical procedure performed on the second internal organ.

The need for the additional surgical personnel to manipulate and hold the surgical graspers or other similar retracting instruments during the surgical procedure increases the costs of surgery. In addition, the additional incisions in the abdominal wall required for the surgical graspers or other similar retracting instruments often results in additional discomfort to the patient following surgery and additional scarring.

What is needed to overcome these disadvantages associated with the above-described type of laparoscopic surgical procedure is an apparatus that can be operated to intra-abdominally move a first internal organ to a position away from a second internal organ and then hold the first internal organ in the position without requiring additional manual input other than that provided by the surgeon and without requiring additional abdominal incisions other than those required for the surgery.

SUMMARY OF THE INVENTION

The present invention overcomes the above-described shortcomings of laparoscopic surgical procedures by providing an apparatus that can be inserted into the abdominal cavity through the same incision to be used in a laparoscopic surgery procedure, and the method of using the apparatus to move or retract a first internal organ, for example the liver, away from a second internal organ, for example the stomach, and then

hold the first internal organ in the retracted position providing surgical access to the second internal organ without requiring further manual input.

The apparatus is constructed of component parts that are often used in laparoscopic as well as other types of surgical procedures. The component parts will be described herein using their common understood names and their functions, without going into details of the particular constructions of the component parts.

The basic construction of the apparatus of the invention includes a length of cord. The cord could be comprised of a first cord segment having a flexible length with opposite first and second ends, and a second cord segment having a flexible length with opposite first and second ends. The cord segments could be provided by lengths of suture, lengths of tubing such as IV tubing, lengths of umbilical tape or elastic strips, or other equivalent cord constructions. The first and second cord segments could be separate cord segments that are attached together, or could be two cord segments of a single continuous length of cord.

First, second, and third separate tissue connectors are attached to the first and second cord segments. The tissue connectors can be any type of known tissue connector that can be manually manipulated to connect to body tissue, and then manually manipulated to be removed from the body tissue without leaving any significant damage to the body tissue. In addition, the tissue connectors can be biocompatible tissue connectors that are designed to be left in the abdominal cavity after the surgery. Some examples of such tissue connectors include suture needles, "T" bars, graspers, barbed needles, hooks, clasps, rivet assemblies, or any other equivalent type of connector. The first and third tissue connectors are attached to the opposite ends of the first cord segment and the second and third tissue connectors are attached to the opposite ends of the second cord segment. This positions the first and second tissue connectors at the opposite ends of the combined lengths of the first and second cord segments, and positions the third tissue connector at an intermediate position of the combined lengths of the first and second cord segments.

In the use of the apparatus according to the method of the invention, the apparatus is first manually passed through the abdominal wall, for example through an incision or a cannula in the abdominal wall, and is positioned in the abdominal cavity in the area of the first and second internal organs. The third tissue connector is then manually connected to tissue adjacent the first internal organ. This positions the ends of the first and second cord segments connected to the third tissue connector between the first and second internal organs and on an opposite side of the first internal organ from the abdominal wall. The first tissue connector attached to the opposite end of the first cord segment from the third tissue connector is manually moved causing the length of the first cord segment to move and engage across the first internal organ and to move the first internal organ toward the position away from the second internal organ. The first tissue connector is then manually connected to the abdominal wall.

The second tissue connector attached to the opposite end of the second cord segment from the third tissue connector is then manually moved causing the second cord segment to move and engage across the first internal organ and move the first internal organ toward the position away from the second internal organ. The second tissue connector is then manually connected to the abdominal wall.

In the above matter, the first and second cord segments engaging across the first internal organ hold the first internal

organ at the position away from the second internal organ without further manual input. This provides surgical access to the second internal organ.

In a further embodiment of the apparatus of the invention, the apparatus is comprised of a cord having a continuous flexible length with opposite first and second ends. A needle is attached to one end of the length of cord and a knot is formed in the opposite end of the length of cord.

According to the method of use of this embodiment of the apparatus, the apparatus is first positioned inside the abdominal cavity in the same manner as the previously-described embodiment. The knotted end of the length of cord is then connected to tissue adjacent the first internal organ by first passing the needle through the tissue and then manually pulling the length of cord through the tissue. This attaches the knotted end of the cord to the tissue between the first and second internal organs.

The needle is then passed through the inter-abdominal wall and manually moved back into the abdominal cavity, causing a first segment of the length of cord to engage across the first internal organ and move the first internal organ toward the position away from the second internal organ.

The needle is then again inserted through the inter-abdominal wall at a location spaced from the first insertion of the needle through the inter-abdominal wall, and the needle and length of cord are pulled manually into the abdominal cavity.

The needle and the end of the length of cord attached to the needle are then passed through the knot formed at the opposite end of the length of cord and pulled tight, causing a second segment of the length of cord to engage across and move the first internal organ toward the position away from a second internal organ. A knot is then tied between the opposite ends of the length of cord and the portion of the cord extending from the knot to the needle is cut and removed with the needle from the abdominal cavity. The length of cord left in the abdominal cavity forms a triangular loop with first and second cord segments that engage across and hold the first internal organ in the position away from the second internal organ without manual input. In this manner, surgical access is provided to the second internal organ without manual input.

As described above, the apparatus of the invention and its method of use enable intra-abdominally moving a first internal organ to a position away from a second internal organ where the apparatus holds the first internal organ in the position without manual input.

DESCRIPTION OF THE DRAWING FIGURES

Further features of the apparatus of the invention and its method of use are set forth in the following detailed description of the apparatus and method and are shown in the drawing figures.

FIG. 1 is a plan view of one embodiment of the apparatus of the invention.

FIG. 2 is a plan view of a further embodiment of the apparatus of the invention.

FIG. 3 is a plan view of a still further embodiment of the apparatus of the invention.

FIG. 4 is a representation of the apparatus of FIG. 1 being inserted into the abdominal cavity.

FIG. 5 is a representation of the apparatus of FIG. 1 being used according to the method of the invention.

FIG. 6 is a representation of the apparatus of FIG. 2 in use according to the method of the invention.

FIG. 7 is a representation of the apparatus of FIG. 3 in use according to the method of the invention.

FIGS. 8A-8E represent the insertion of one embodiment of the apparatus into the abdominal cavity and one method of use of the apparatus.

FIGS. 9A-9E represent the insertion of a further embodiment of the apparatus into the abdominal cavity and the method of using the apparatus.

FIGS. 10A and 10B represent the insertion of a further embodiment of the apparatus into the abdominal cavity and the method of using the apparatus.

FIGS. 11A and 11B represent a further embodiment of the apparatus and its method of use.

FIGS. 12A and 12B represent a further embodiment of the apparatus and its method of use.

FIGS. 13A and 13B represent a further embodiment of the apparatus and its method of use.

FIGS. 14A-14C represent a further embodiment of the apparatus and its method of use.

FIGS. 15A and 15B represent a further embodiment of the apparatus and its method of use.

FIGS. 16A and 16B represent a further embodiment of the apparatus and its method of use.

FIG. 17 represents a further embodiment of the apparatus and its method of use.

FIGS. 18A and 18B represent a further embodiment of the apparatus and its method of use.

FIGS. 19A and 19B represent a further embodiment of the apparatus and its method of use.

FIGS. 20A and 20B represent a further embodiment of the apparatus and its method of use.

FIGS. 21A and 21B represent a further embodiment of the apparatus and its method of use.

FIGS. 22A and 22B represent a further embodiment of the apparatus and its method of use.

FIG. 23 represents a further embodiment of the apparatus and its method of use.

FIGS. 24A-24C represent component parts of a further embodiment of the apparatus.

FIG. 25 represents a component part of a further embodiment of the apparatus.

FIG. 26 represents a component part of a further embodiment of the apparatus.

FIG. 27 represents a further embodiment of the apparatus.

FIG. 28 represents a further embodiment of the apparatus.

FIG. 29 represents a further embodiment of the apparatus.

FIG. 30 represents a further embodiment of the apparatus.

FIG. 31 represents a further embodiment of the apparatus.

FIG. 32 represents a further embodiment of the apparatus.

FIG. 33 represents a component part of an embodiment of the apparatus.

FIG. 34 represents a component part of an embodiment of the apparatus.

FIG. 35 represents a component part of an embodiment of the apparatus.

FIG. 36 represents a component part of an embodiment of the apparatus.

FIG. 37 represents a component part of an embodiment of the apparatus.

FIG. 38 represents a component part of an embodiment of the apparatus.

FIGS. 39A-39C represent component parts of an embodiment of the apparatus.

FIGS. 40A and 40B represent component parts of an embodiment of the apparatus.

FIG. 41 represents a component part of an embodiment of the apparatus.

FIG. 42 represents a component part of an embodiment of the apparatus.

FIG. 43 represents a component part of an embodiment of the apparatus.

FIGS. 44A and 44B represent component parts of an embodiment of the apparatus.

FIGS. 45A-45E represent component parts of an embodiment of the apparatus.

FIGS. 46A-46E represent component parts of an embodiment of the apparatus and its method of use.

FIGS. 47A-47D represent component parts of an embodiment of the apparatus and its method of use.

FIGS. 48A-48D represent component parts of an embodiment of the apparatus and its method of use.

FIGS. 49A and 49B represent component parts of an embodiment of the apparatus and its method of use.

FIGS. 50A and 50B represent component parts of an embodiment of the apparatus and its method of use.

FIGS. 51A-51E represent a method of positioning an embodiment of the apparatus in an abdominal insertion device.

FIGS. 52A and 52B represent embodiments of the apparatus and an insertion device and the method of mounting the apparatus on the insertion device.

FIG. 53 represents embodiments of the apparatus and an insertion device and a method of mounting the apparatus on the insertion device.

FIG. 54 represents embodiments of the apparatus and an insertion device and a method of mounting the apparatus in the insertion device.

FIGS. 55A-55C represent an embodiment of the apparatus and a method of using the apparatus.

DETAILED DESCRIPTION OF THE PREFERRED EMBODIMENT

FIG. 1 shows one embodiment 12 of the apparatus for intra-abdominally moving a first internal organ to a position away from a second internal organ and then holding the first internal organ in the position without manual input. As stated earlier, the apparatus 12 is constructed of component parts that are often used in laparoscopic instruments and procedures as well as other types of surgical instruments and procedures. Because such component parts are known, the component parts that make up the apparatus 12 of the invention will be described herein using their common understood names and functions, without going into the details of the particular constructions of the component parts. As is conventional with laparoscopic apparatus, the component parts of the apparatus are dimensioned to be inserted through an incision in the abdominal wall or through a cannula extending through the abdominal wall to position the apparatus in the abdominal cavity.

The basic construction of the apparatus 12 of the invention includes a length of cord. In the example of FIG. 1 the cord length is 10 inches, but the size of the apparatus 12 could change depending on the size of the patient in which the apparatus is used. In the embodiment shown in FIG. 1, the cord is comprised of a first cord segment 14 having a flexible length with opposite first 16 and second 18 ends, and a second cord segment 22 having a flexible length with opposite first 24 and second 26 ends.

The cord segments 14, 22 could be provided by lengths of suture, lengths of tubing such as IV tubing, lengths of umbilical tape or elastic strips, or other equivalent cord constructions. The tubing or tape configurations of the cord segments have the advantage of being less likely to dig into or cut into the first internal organ in use of the apparatus to be described.

The first 14 and second 22 cord segments could be separate cord segments that are attached directly together, or separate cord segments that are attached by way of a further cord segment 28 or some other component part of the apparatus, or two cord segments of a single continuous length of cord such as the two cord segments 14a, 22a shown in FIG. 2.

First 32, second 34, and third 36 separate tissue connectors are attached to the first 14 and second 22 cord segments. The tissue connectors 32, 34, 36 can be any type of known tissue connector that can be manually manipulated to connect to body tissue, and then manually manipulated to be removed from the body tissue without leaving any significant damage to the body tissue. In addition, the tissue connectors 32, 34, 36 could be biocompatible tissue connectors that are designed to be left in the abdominal cavity after the surgical procedure is completed. Some examples of tissue connectors include suture needles, "T" bars, surgical graspers, barbed needles, hooks, clasps, rivet assemblies, or any other equivalent type of connector. In the apparatus of the invention, it is not necessary that all three tissue connectors 32, 34, 36 be the same type of tissue connector. Because various different types of tissue connectors may be employed with the apparatus 12 of the invention, the three tissue connectors 32, 34, 36 of the apparatus 12 are represented schematically in the drawing figures. The first 32 and third 36 tissue connectors are attached to the opposite ends of the first cord segment 14. The third tissue connector 36 is also attached to one end of the second cord segment 22, with the second tissue connector 34 being connected to the opposite end of the second cord segment 22. This positions the first 32 and second 34 tissue connectors at the opposite ends of the combined lengths of the first 14 and second 22 cord segments, and positions the third tissue connector 36 at an intermediate position of the combined length of the first 14 and second 22 cord segments. In FIG. 1, the first 32 and second 34 tissue connectors are shown connected to the respective first end 16 of the first cord segment 14 and the first end 24 of the second cord segment 22 through the intermediary of additional cord segments 38, 40. The third tissue connector 36 is shown connected to the second end 18 of the first cord segment 14 and the second end 26 of the second cord segment 22 through the intermediary of a further cord segment 28. FIG. 2 shows the apparatus 12 with the first 32 and second 34 tissue connectors connected directly to the respective first end 16 of the first cord segment 14 and the first end 24 of the second cord segment 22. FIG. 2 also shows the third tissue connector 36 connected directly to the second ends 18, 26 of the first cord segment 14 and the second cord segment 22.

FIGS. 4 and 5 illustrate an example of the use of the apparatus 12 of FIG. 1 according to the method of the invention. In use, the apparatus 12 is first manually passed through the abdominal wall 42, for example through an incision or a cannula 44 in the abdominal wall 42, and is positioned in the abdominal cavity 46 in the area of the first 48 and second 50 internal organs. In FIG. 4, the first internal organ 48 represented is the human liver, and the second internal organ 50 represented is the human stomach.

The third tissue connector 36 of the apparatus is then manually connected to tissue 52 adjacent the first internal organ 48 and between the first 48 and second 50 internal organs. In the example shown in FIG. 4, the tissue 52 is the crus of the diaphragm. Connection of the third tissue connector 36 to the tissue 52 positions the second ends 18, 26 of the first 14 and second 22 cord segments connected to the third tissue connector 32 between the first 48 and second 50 internal organs and on an opposite side of the first internal organ 48 from the abdominal wall 42.

The first tissue connector **32** attached to the opposite end **16** of the first cord segment **14** from the third tissue connector **36** is then manually moved causing the length of the first cord segment **14** to move and engage across the first internal organ **48**. Continued movement of the first tissue connector **32** causes the first cord segment **14** engaging across the first internal organ **48** to move the first internal organ toward a position away from the second internal organ **50**. The first tissue connector **32** is then manually connected to the inner abdominal wall **42**.

The second tissue connector **34** attached to the opposite end **24** of the second cord segment **22** from the third tissue connector **36** is then manually moved causing the second cord segment **22** to move and engage across the first internal organ **48**. Continued movement of the second tissue connector **34** causes the second cord segment **22** engaging across the first internal organ **48** to move the first internal organ **48** toward the position away from the second internal organ **50**. The second tissue connector **34** is then manually connected to the inner abdominal wall **42**.

With the apparatus **12** connected between the tissue **52** and the inner abdominal wall **42** in the manner discussed above, the first cord segment **14** and the second cord segment **22** engage across the first internal organ **48** and hold the first internal organ **48** at the position away from the second internal organ **50** without further manual input. This provides surgical access to the second internal organ **50**. Without requiring manual holding or restraining of the first internal organ **48** in the position away from the second internal organ **50**.

FIG. **6** is a representation of the apparatus of FIG. **2** that has been connected between the tissue **52** and the inner abdominal wall **42** according to the same method as the apparatus of FIG. **1** described above.

In a further embodiment of the apparatus of the invention shown in FIG. **3**, the apparatus **54** is comprised of a single cord **56** having a continuous flexible length with opposite first **58** and second **60** ends. A tissue connector in the form of a needle **62** is attached to the first end **58** of the length of cord **56**. At the opposite second end **60** of the length of cord **56**, the cord is formed in a knot **64**.

The method of using the embodiment of the apparatus **54** shown in FIG. **3** is illustrated in FIG. **7**. The apparatus **54** is first positioned inside the abdominal cavity in the same manner as the previously described embodiments. The knotted end **64** of the length of cord is then connected to the tissue **52** adjacent the first internal organ **48** by first passing the needle **62** through the tissue **52** and then manually pulling the needle **62** and the attached length of cord **56** through the tissue **52**. This attaches the knotted second end **64** of the length of cord **56** to the tissue **52** between the first **48** and second **50** internal organs.

The needle **62** is then passed through the inter-abdominal wall **42** and the needle **62** and the attached length of cord **56** are pulled from the insertion site **72** back into the abdominal cavity **46**. This causes a first segment **74** of the cord length **56** to move into engagement with and across the first internal organ **48**. The engagement of the first cord segment **74** with the first internal organ **48** moves the first internal organ **48** toward the position away from the second internal organ **50**.

The needle **62** is then again inserted through the inter-abdominal wall **42** at a second insertion location **76** spaced from the first insertion location **72**. The needle **62** and the attached length of cord **56** are pulled manually through the second insertion **76** into the abdominal cavity **46** until an intermediate section of cord **78** extends between the two insertion sites **72, 76**.

The needle **62** and the attached length of cord **56** are then passed through the knot **64** formed at the opposite end of the length of cord **56** and are pulled tight. This causes a second cord segment **82** of the length of cord **56** to engage across and move the first internal organ **48** toward the position away from the second internal organ **50**. The length of cord **56** is pulled tight and a knot is tied between the opposite ends of the cord at the knot **64** on the cord second end **60**. The portion of the length of cord **54** extending from the knot **64** to the needle **62** is then cut and removed from the abdominal cavity. The length of cord **54** left in the abdominal cavity forms a triangular loop with the first **56** and second **82** cord segments extending across the first internal organ **48** and holding the first internal organ in the position away from the second internal organ **50** without manual input. In this manner, surgical access is provided to the second internal organ **50** without manually holding the first internal organ **48** in its retracted position.

FIGS. **8A-8E** represent one method of inserting the apparatus of the invention into the abdominal cavity and the method of using the apparatus. The embodiment of the apparatus **12** shown in these drawing figures has a pair of keith needles **80, 82** as the first and second tissue connectors, and a "T" bar **84** as the third tissue connector. The apparatus **12** is first positioned inside an insertion device **86** in the form of a hollow narrow tube. The insertion device **86** is then inserted through a trocar or cannula **44** that has been positioned in the abdominal wall **42** in a conventional manner. Once inside the abdominal cavity **46**, the apparatus **12** is removed from the interior of the insertion device **86** and the insertion device is removed from the abdominal cavity through the cannula **44**. The "T" bar **84** or the third tissue connector is then passed through the body tissue **52**, i.e., the right diaphragm crus as described earlier. Once the "T" bar **84** is passed through the tissue **52**, it is rotated to its substantially 90 degree position relative to its pathway through the tissue **52** as shown in FIG. **8C**. The apparatus **12** is then pulled from the keith needles **80, 82**. As represented in FIG. **8D**, the keith needles **80, 82** are then passed through the abdominal wall **42** and the apparatus is pulled tight against the first internal organ **48**, i.e., the liver. The needles **80, 82** are then pulled at the exterior of the abdominal wall **42**, causing the apparatus to move the first internal organ **48** away from the second internal organ, i.e., the stomach. A pair of tension clasps **88, 90** are attached to the respective first **14** and second **22** cord segments of the apparatus on the exterior of the abdominal wall **42** to hold the apparatus in its position across the first internal organ **48** in the abdominal cavity **46**.

FIGS. **9A-9E** represent a method of using an embodiment of the apparatus **12** that is similar to that shown in FIGS. **8A-8E** and described above. In this example, the apparatus **12** also employs the "T" bar **84** as its third tissue connector. However, there is no needle provided on the first cord segment **14** and there is no needle provided on the second cord segment **22**. In this embodiment of the apparatus **12**, the first cord segment **14** is a length of suture having a free end **92** opposite the "T" bar **84** and the second cord segment **22** is a length of suture also having a free end **94** opposite the "T" bar **84**. The apparatus **12** is shown in FIG. **9A** as being positioned in the abdominal cavity **46** using the insertion device **86** in the same manner described earlier with reference to the method of FIGS. **8A-8E**. The apparatus **12** of FIG. **9A** is also initially used according to the same method of FIGS. **8A-8E** in that the "T" bar **84** is passed through the body tissue **52** and is positioned substantially 90 degrees relative to the pathway through the tissue. A pair of GraNee needles **96, 98** are then passed through the abdominal wall **42**. One of the GraNee

needles **96** grabs the suture free end **92** of the first cord segment **14** and the other GraNee needle **98** grabs the suture free end **94** of the second cord segment **22**. The GraNee needles **96**, **98** are then withdrawn through the abdominal wall **42** pulling the suture free ends **92**, **94** through the abdominal wall. The suture free ends **92**, **94** are then secured to the abdominal wall using a pair of clamps **88**, **90** as was done in the previously-described embodiment of FIGS. **8A-8E**.

FIGS. **10A** and **10B** are a representation of the method of the invention practiced using an ENDO STITCH® device marketed by United States Surgical Corporation. FIG. **10A** represents the distal end of the ENDO STITCH® **102** being inserted through the cannula **44** in the abdominal wall **42** to a position adjacent the diaphragm crus **52**. As is conventional, the pair of jaws **104**, **106** at the ENDO STITCH® distal end **102** hold a needle **108** and a length of suture **110**. The ENDO STITCH® **102** is manually actuated to pass the needle **108** through the tissue **52** of the crus from one jaw **104** of the ENDO STITCH® to the opposite jaw **106** of the ENDO STITCH®. The length of suture **110** is then removed from the abdominal cavity **46** through the cannula **44** and is pulled tight, causing the length of suture **110** to move and hold the first internal organ away from the second internal organ in substantially the same manner as described earlier.

FIGS. **11A** and **11B** represent a further embodiment of the apparatus **12** and its method of use. The embodiment of the apparatus **12** shown in FIGS. **11A** and **11B** and its method of use are substantially the same as that of earlier-described embodiments, except that the "T" bar of the previously-described embodiments is replaced by a "J" hook locking clasp **112**. FIG. **11A** shows the locking clasp **112** in its open position prior to the hook portion of the clasp being passed through the tissue **52** of the diaphragm crus. FIG. **11B** shows the locking clasp **112** after the hook of the clasp has been passed through the tissue **52** and the clasp has been locked. The method of further using the apparatus to move and hold an internal organ is substantially the same as that of earlier-described embodiments.

FIGS. **12A** and **12B** show a further embodiment of the apparatus **12** and its method of use. The construction of the embodiment of the apparatus **12** shown in FIGS. **12A** and **12B** is substantially the same as earlier described embodiments, except that the "T" bar or locking clasp is replaced by a barbed needle **114**. The method of using the embodiment of the apparatus shown in FIGS. **12A** and **12B** is substantially the same as that of earlier described embodiments, except that the barbed needle **114** is passed through the tissue **52** of the diaphragm crus until the barb of the needle emerges from the tissue as shown in FIG. **12B**. This secures the apparatus to the tissue **52**. Further use of the apparatus to move and hold an internal organ is substantially the same as that of earlier-described embodiments.

FIGS. **13A** and **13B** show a further embodiment of the apparatus **12** of the invention that is substantially the same as that as earlier-described embodiments except that the third tissue connector or "T" bar is replaced by a resilient biased clasp **116**. In the method of using the apparatus of FIGS. **13A** and **13B**, the opposite arms **118**, **120** of the clasp **116** are compressed to open the jaws **122**, **124** of the clasp as shown in FIG. **13A**. The jaws **122**, **124** are then positioned around the tissue **52** of the diaphragm crus and are allowed to close, thereby securing the clasp **116** to the tissue **52**. The subsequent method of using the apparatus shown in FIGS. **13A** and **13B** is substantially the same as that of previously-described embodiments of the apparatus.

FIGS. **14A-14C** show a further embodiment of the apparatus **12** that is substantially the same as that of previously-described embodiments except that the third tissue connector is a two-piece rivet assembly. The assembly is comprised of a pin **126** having an enlarged point **128** and a cap **130** having a circular center opening **132**. In the method of using the apparatus of FIGS. **14A-C**, the pin **126** is first inserted through the tissue **52** of the diaphragm crus until the point **128** projects from the opposite side of the tissue. The point **128** is then inserted through the center opening **132** of the cap **130**, thereby securing the pin **126** and the cap **130** to the tissue **52**. The subsequent steps of using the apparatus of FIGS. **14A-14C** is substantially the same as that of earlier-described embodiments of the apparatus.

FIGS. **15A** and **15B** show a further embodiment of the apparatus **12** that has substantially the same construction of earlier-described embodiments of the apparatus except for the first and second tissue connectors being a pair of "J" shaped hooks **134**, **136**. In the method of using the embodiment of the apparatus shown in FIGS. **15A** and **15B**, the first cord segment **14** and the second cord segment **22** are secured to the inner abdominal wall **42** by passing the hooks **134**, **136** through the tissue of the inner abdominal wall. Apart from this, the method of using the apparatus shown in FIGS. **15A** and **15B** is substantially the same as that of earlier-described embodiments of the apparatus.

FIGS. **16A** and **16B** represent a further embodiment of the apparatus and its method of use that are substantially the same as that of previously-described embodiments, except for the first and second tissue connectors being a pair of "J" hook locking clasps **138**, **140**. In the method of using the apparatus of FIGS. **16A** and **16B**, the hook portions of the locking clasps **138**, **140** are passed through the tissue of the inner abdominal wall **42** and then are locked closed. This secures the first cord segment **14** and the second cord segment **22** to the inner abdominal wall. Apart from this, the method of using the apparatus of the invention shown in FIGS. **16A** and **16B** is substantially the same as that of earlier-described embodiments of the apparatus.

FIG. **17** shows a representation of an embodiment of the apparatus where the first and second tissue connectors are provided as a pair of resilient, biased clasps **142**, **144** that have substantially the same construction of the earlier-described clasp **116**. The clasps **142**, **144** are secured to the inner abdominal wall **42** by first opening the clasps and positioning tissue of the inner abdominal wall between the open jaws of the clasps, and then allowing the jaws of the clasps to close over the tissue. This secures the first cord segment **14** and the second cord segment **22** to the inner abdominal wall. Apart from this, the method of using the apparatus represented in FIG. **17** is substantially the same as that as earlier-described embodiments of the apparatus.

FIGS. **18A** and **18B** show an embodiment of the apparatus and its method of use that is substantially the same as that of FIG. **7**. The embodiment of FIGS. **18A** and **18B** differs from that of the FIG. **7** embodiment in that the free ends **146**, **148** of the length of suture **150** are tied in a knot completing the triangular loop configuration of the length of suture **150** at a location that is displaced from the portion of the suture **150** passed through the tissue **52** of the diaphragm crus. Apart from this, the method of using the apparatus of the invention shown in FIGS. **18A** and **18B** is substantially the same as that of the embodiment of the apparatus shown in FIG. **7**.

FIGS. **19A** and **19B** show a further embodiment of the apparatus and its method of use. The apparatus shown in these drawing figures is comprised of a length of cord **152** with a circular pledget **154** secured at one end of the cord and a

needle, for example a Keith needle 156, secured to the opposite end of the cord. The cord 152 could be a length of suture or other similar material. In the method of using the apparatus shown in FIGS. 19A and 19B, the needle 156 is first passed through the abdominal wall 42 and into the abdominal cavity 46. The needle 156 is then passed through the tissue 52 of the diaphragm crus. The needle 156 is then again passed through the abdominal wall 42 to the exterior of the abdomen and is pulled tight. This results in the length of cord 152 engaging against and moving the first internal organ away from the second internal organ in substantially the same manner as previously-described embodiments. The tight length of cord 152 is then secured in place by a clasp 158 attached to the length of cord 152 against the exterior of the abdominal wall 42.

FIGS. 20A and 20B show a representation of a further embodiment of the apparatus and its method of use. In FIG. 20A, the apparatus is shown comprised of a length of cord 160 having a circular pledget 162 at one end and a needle, for example a Keith needle 164, at the opposite end. The apparatus also includes a second shorter length of cord 166 with a "T" bar 168 at one end and a loop 170 formed in the opposite end. In the embodiment, the cords 160, 166 may be suture or other similar materials. The method of using the apparatus is represented in FIG. 20B. The "T" bar 168 is first secured to the tissue 52 of the diaphragm crus. The needle 164 is then passed through the tissue of the inner abdominal wall 42, through the loop 170 and then through the abdominal wall 42 to the exterior of the abdomen. Pulling the needle 164 on the exterior of the abdomen pulls the cord 160 tight across the internal organ to move and hold the internal organ in substantially the same manner as that of previously-described embodiments of the apparatus.

FIGS. 21A and 21B show a further embodiment of the apparatus that is substantially the same as that of the embodiment of FIGS. 20A and 20B, except that the needle 164 is removed from the end of the length of cord 160, leaving a free end 172 of the cord. The method of using this embodiment of the apparatus is substantially the same as that of the previously-described embodiment except for the step of passing the cord free end 172 through the abdominal wall 32. A GraNee needle (not shown) may be used to perform this step of the method.

FIGS. 22A and 22B show a further embodiment of the apparatus that is substantially the same as that of the previously-described embodiment, except that it is comprised of only the length of cord 160 having the circular pledget 162 at one end and a free end 172 of the cord at the opposite end. In the method of using this embodiment of the apparatus, the suture free end 172 is first passed through the inner abdominal wall 42, then through the tissue 52 of the diaphragm crus, and then through and out of the abdominal wall 42. As in the previously-described embodiment, the suture free end 172 can be passed through the tissue of the abdominal wall 42 and the crus 52 using a GraNee needle or other similar instrument. The length of cord 160 is pulled tight to move and hold the first internal organ relative to the second internal organ in substantially the same manner as previously-described method embodiments of the apparatus.

FIG. 23 shows a further embodiment of the apparatus that is substantially the same as that of earlier-described embodiments except for the first and second tissue connectors being "J" hook locking clasps 174, 176 that incorporate one-way clutch mechanisms. The ends of the cord segments 14, 22 can be pulled through the clutch mechanisms of the clasps 174,

176 in one direction, but are prevented by the clutch mechanisms from being pulled through the clasps 174, 176 in the opposite directions.

FIGS. 24A-24C show representations of a "J" hook locking clasp such as that shown in FIG. 23, with a one-way clutch mechanism. The one-way clutch mechanism is comprised of a rotatable pulley 178 and a "V" shaped groove 180 positioned adjacent the pulley 178. An end portion of the cord 182 is threaded through the "V" shaped groove 180 and then around the pulley 178. When the end of the cord 182 extending from the pulley 178 is pulled tight, the relative positions of the pulley 178 and the groove 180 cause the portion of the cord 182 to wedge and become locked in the bottom of the groove 180.

FIG. 25 shows a further representation of the embodiment of the apparatus employing a "J" hook locking clasp 184 with a one-way clutch mechanism. The one-way clutch mechanism is comprised of a pair of pivoting cams 186, 188 having opposing ratchet tooth surfaces 190, 192. A portion of the apparatus cord 194 is threaded between the opposed tooth surfaces. The portion of cord 194 can be pulled through the spacing between the cam ratchet tooth surfaces 190, 192 in one direction, for example to the left in FIG. 25, but the cams 186, 188 pivot toward each other and their ratchet tooth surfaces 190, 192 clamp the cord portion 194 between the surfaces when the cord portion is pulled in the opposite direction, for example to the right as shown in FIG. 25.

FIG. 26 shows a representation of a further embodiment of the "J" hook clasp 196 having a one-way clutch mechanism. In this embodiment, the one-way clutch mechanism is comprised of a toothed wheel 198 that engages with the cord portion 200 pulled through the clasps 196. The tooth wheel 198 also has a smaller ratchet wheel 202 at its center. The ratchet wheel 202 engages against a resilient pawl 204. The ratchet wheel 202 and resilient pawl 204 function in the conventional manner allowing the toothed wheel 198 to rotate in one direction when the cord portion 200 is pulled through the clutch mechanism, for example to the right as shown in FIG. 26, but prevent the rotation of the toothed wheel 198 and the movement of the cord portion 200 when the cord portion is pulled in the opposite direction, for example to the left as shown in FIG. 26.

FIGS. 27-32 show several different representations of the possible constructions of the cord segments 14, 22, 38 of the apparatus of the invention. In FIGS. 27-32 the first and second tissue connectors are represented by needles, for example Keith needles 80, 82. The third tissue connector is represented by a "T" bar 84. It should be understood that these are only examples of only three tissue connectors that could possibly be used with the apparatus of the invention, and that other forms of tissue connectors, for example the types described herein could be used as the three tissue connectors on the apparatus.

FIG. 27 shows the first 14, second 22 and third 38 cord segments as being constructed of suture material.

FIG. 28 shows the first 14 and second 22 cord segments being part of a single length of surgical tape or strap, and the third cord segment 38 being constructed of suture.

FIG. 29 shows the first 14 and second 22 cord segments being constructed of lengths of suture inserted through lengths of surgical tubing. The third cord segment 38 is constructed of suture.

FIG. 30 shows the apparatus as having first 14 and second 22 cord segments constructed of combinations of surgical tape and suture connected end to end. The third cord segment 38 is constructed of suture material.

FIG. 31 shows the apparatus being constructed of first 14 and second 22 cord segments formed from a single length of suture material inserted through a single length of surgical tubing. The third cord segment 38 is constructed of suture material.

FIG. 32 shows the apparatus as having the first 14 and second 22 cord segments constructed of a single continuous length of surgical tape having lengths of suture at opposite ends. The third cord segment 38 is constructed of suture material.

FIGS. 33-45 show examples of some of the various different types of tissue connectors that could be used as any one of the tissues connectors 32, 34, 36 of the apparatus. These are only some of the possible types of tissue connectors, and the connectors shown in FIGS. 33-45 should not be interpreted as limiting the apparatus to the particular tissue connectors shown.

FIG. 33 shows a "T" bar 84 as one example of any one of the three tissue connectors 32, 34, 36.

FIG. 34 shows a barbed needle 114 as any one of the three tissue connectors 32, 34, 36.

FIG. 35 shows the two-piece rivet pin 126 and cap 130 connector that can be used as any one of the three tissue connectors 32, 34, 36.

FIG. 36 shows the "J" hook locking clasp 112 that can be used as any one of the three tissue connectors 32, 34, 36.

FIG. 37 shows the resilient, biased clasp 116 that could be used as any one of the three tissue connectors 32, 34, 36.

FIG. 38 shows a cross-section of an embodiment of a "J" hook locking clasp. The embodiment shown is comprised of a cylindrical housing 206 that contains the "J" hook 208 and a coil spring 210 that biases the "J" hook 208 to its closed position.

FIGS. 39A-39C show a variation of the "J" hook locking clasp of FIG. 38 where the coil spring 210 is replaced by a spiral band spring 212. FIG. 39B shows the spiral and spring 212 in its extended configuration, and FIG. 39C shows the spring in its compressed configuration.

FIGS. 40A and 40B show a tissue connector clasp that is comprised of a pair of resilient jaws 214, 216 that project from one end of a hollow housing 218, and a pin 220 connected to the jaws that projects from the opposite end of the housing. A spring 222 contained in the housing 218 biases the pin 220 and the jaws 214, 216 to the left as shown in FIG. 40A. This causes the resilient jaws to move to their open position shown in FIG. 40A. Pulling the pin 220 to the right against the bias of the spring 222 causes the housing to slide against the opposite sides of the jaws 214, 216 and move the jaws to their closed position.

FIG. 41 shows a side view of the resilient biased clasp 116 described earlier. Compressing the opposite arms 118, 120 of the clasp 116 causes the jaws 122, 124 to separate. Releasing the compression force causes the jaws 122, 124 to move together under the bias of the resilience of the clasp 116.

FIG. 42 shows an embodiment of a clasp comprised of a first jaw 224 and first arm 226 connected by a pivot connection 228 to a second jaw 230 and second arm 232. An oblong cam 234 on a toothed cam wheel 236 is positioned between the pair of arms 226, 232. A toothed actuator wheel 238 meshes with the toothed cam wheel 236. Rotation of the actuator wheel 238 will cause rotation of the cam wheel 236 and the cam 238. Rotation of the cam 234 to its position shown in FIG. 42 pushes the pair of arms 226, 232 away from each other which in turn causes the pair of jaws 224, 230 to move toward each other. Rotation of the cam 234 90 degrees or one-quarter turn from its position shown in FIG. 2 will cause the jaws 242, 230 to move away from each other.

FIG. 43 shows an embodiment of a clasp comprised of a first jaw 240 and first arm 242 connected by a pivot connection 244 to a second jaw 246 and second arm 248. A spring 250 is positioned between the pair of arms 240, 248 and biases the arms away from each other. This in turn biases the first jaw 242 and second jaw 246 toward each other. The jaws 242, 246 are opened by applying a compression force to the opposite sides of the first arm 240 and second arm 248 that compresses the spring 250.

FIGS. 44A-44B show a side-sectioned view of a construction of the rivet assembly described earlier. As seen in the drawing figures, the pin head 128 is slightly larger in diameter than the cap hole 132. When the pin 126 is attached to the cap 130, there is a fixed gap or maximum distance between a circular head 252 of the pin 126 and the cap 130.

FIGS. 45A-45E show a further embodiment of a rivet assembly. In this assembly, the rivet pin 254 has several notches 256 along its length between the pin head 258 and the pin point 260. The rivet cap 262 is similar in construction to that of the previously-described embodiment with a center opening or hole 264 extending through the cap. However, the cap 262 is also formed with a transverse slot 266 that intersects the center hole 264 and a parallel slot 268 that extends into the cap 262 parallel to the center hole 264 and intersects the transverse slot 266. A locking tab 270 with a pin hole 272 and a spring hole 274 is inserted in the transverse slot 266 for sliding movement therein. A resilient wire spring 276 is inserted downwardly into the parallel slot 268 and through the tab pin hole 272. Inserting the rivet pin 254 into the cap center hole 264 and through the tab pin hole 272 causes the pin to slide the tab to the left as shown in FIG. 45A against the bias of the wire spring 276. As a pin notch 256 passes through the tab hole 272, the bias of the spring 276 causes the tab 270 to move to the right and into the notch 256. This locks the pin 254 in place relative to the cap 262. With the pin 254 having a number of notches, and in the example of FIG. 45A having three notches, the position of the pin head 258 relative to the cap 262 can be adjusted between three positions. This provides an adjustable gap or an adjustable distance between the pin head 258 and the cap 262.

FIGS. 46A-46E represent a further embodiment of the apparatus of the invention. This embodiment is comprised of a length of cord 278 having a needle 280 at one end and a loop 282 formed at the opposite end. A circular pledget 284 is provided on the length of cord 278 toward the loop end of the cord. The apparatus also includes a locking collar having a hollow cylindrical housing 286 that contains a tubular one-way suture lock 288. The suture lock 288 is basically cylindrical but is formed with a resilient tab 290 that projects toward the center of the cylindrical configuration of the suture lock. FIG. 46E shows a cross-section representation of the collar cylindrical housing 286 containing the one-way suture lock 288 and a portion of the length of cord 278 extending through the collar. The method of using this embodiment of the apparatus is shown in FIG. 46C. In use in the abdominal cavity 46, the needle 280 is first passed through the tissue 52 in the area of the diaphragm crus, and then is passed a first time through the inner abdominal wall 42. The needle 280 is then moved across the inner abdominal wall 42 and is again passed a second time through the inner abdominal wall. The needle is then inserted through the loop 282 and is pulled tight. This causes the length of cord 278 to form a triangular loop in the abdominal cavity that moves the first internal organ away from the second internal organ and holds the first internal organ in the displaced position in the same manner as previously-described methods of using the apparatus of the invention. The needle 280 is then passed through the collar

cylindrical housing 286 and the housing 286 is moved tight against the cord loop 282. The cord loop 282 is smaller than the housing 286 so that the housing cannot pass through the loop 282. As the length of cord 278 is pulled through the collar housing 286, the locking tab 290 engages against the side of the cord 278 as shown in FIG. 46E. This allows the cord 278 to move through the collar housing 286 in the direction to the right shown in FIG. 46E, but prevents movement of the cord to the left as shown in the figure. In this manner, the apparatus of FIGS. 46A-46E holds the length of cord tight in its triangular loop configuration.

FIGS. 47A and 47B show a further embodiment of the apparatus of the invention and its method of use. The apparatus is comprised of a length of cord 294 having a pledget 296 secured at one end and a needle 298 secured at the opposite end. The apparatus also includes a one-way locking mechanism 300 having a pair of channels 302, 304 through the mechanism dimensioned to receive the length of cord 294. One of the channels 302 allows the length of cord 294 to move through the channel in one direction, but prevents the opposite direction of movement. The other channel 304 allows the length of cord 294 to move through the channel in one direction, but also prevents the opposite direction of movement of the cord 294. As represented in FIG. 47A, the method of using the apparatus first involves the needle 298 passing through the inner abdominal wall until the pledget 296 is positioned up against the wall. The needle 298 then passes through the tissue 52 in the area of the diaphragm crus. The needle 298 is then inserted through the first channel 302 of the one-way locking mechanism 300. The needle 298 is then again passed through the inner abdominal wall at a location spaced from the first insertion site and is then passed through the second channel 304 of the one-way locking mechanism 300. The needle 298 with the length of cord 294 are then pulled tight and the locking mechanism 300 is moved up against the inner abdominal wall at the second needle insertion site. This causes the length of cord 294 to move the first internal organ and hold the first internal organ in its moved position away from the second internal organ in a similar manner to that of earlier-described embodiments.

FIGS. 47C and 47D show the interior of one embodiment of the one-way locking mechanism 300. The mechanism 300 includes a housing first half 306 and a second half 308 that are connected together by a living hinge 310. The open position of the locking mechanism is shown in FIG. 47D. The interior of the two halves 306, 308 of the locking mechanism are formed with grooves 312, 314 that form the two channels 302, 304 through the locking mechanism when the two halves 306, 308 of the locking mechanism are pivoted about the living hinge 310 and snapped together. A "U" shaped spring member 316 is positioned in the first locking mechanism half 306. The spring member 316 has a pair of arms 318, 320 that project from opposite sides of the spring member. Each arm 318, 320 in turn has a resilient locking tab 322, 324 that projects outwardly at an angle from its respective arm 318, 320. The resilient tabs 322, 324 are positioned to engage in sliding engagement along portions of the cord 294 that pass through the channels 302, 304. As shown in FIG. 47D, the one tab 322 will allow the cord 294 to slide across the tab in a direction from right to left as shown in the drawing figure, but will prevent the reverse sliding movement of the cord. The other tab 324 will allow sliding movement of the cord 294 across the tab 324 in a left to right direction as shown in FIG. 47D, but will prevent the reverse movement of the length of cord 294.

FIGS. 48A-48D show a variant embodiment of the one-way locking mechanism 300. As shown in FIG. 48A, the

length of cord is passed through the locking mechanism 328 in much the same manner as the earlier-described locking mechanism 300. However, the second channel 330 of the locking mechanism 328 of FIG. 48A has a block 332 with a hole 334 positioned along the channel. An inclined tooth 336 is positioned in the block hole 334. The portion of the cord length 338 that extends through the locking mechanism channel 330 also extends through the block hole 334. A spring 340 in the locking mechanism 328 biases the block 332 and the tooth 336 toward the portion of cord 338 extending through the locking mechanism channel 330. Due to the inclination of the tooth 336, with the spring 340 biasing the tooth 336 into engagement with the cord portion 338, the cord portion 338 can slide over the tooth 336 as it is moved in a left to right direction as shown in FIG. 48C, but is prevented from moving in the opposite direction. Pressing the block 332 into the locking mechanism 328 against the bias of the spring 340 disengages the tooth 336 from the cord portion 338 and permits the cord portion to move in either direction through the locking mechanism 328.

FIGS. 49A and 49B show a further embodiment of a cord locking mechanism 344 that is similar to that of FIG. 48A. A cross-section of a channel 346 extending through the locking mechanism 344 is shown in FIG. 49A. The channel 346 is formed with pairs of ridges 348, 350 on opposite sides of the channel. A wave form spring 352 is positioned in the channel 346. The spring 352 has grooves 354 formed through peaks formed in the wave form spring. The portion of the cord 356 passing through the locking mechanism channel 346 also passes through the grooves 354 in the wave form spring 352. A button hole 358 is provided in the top of the cord locking mechanism 344 and a release button 360 is positioned in the hole. When the release button 360 is pressed in the hole 358, it engages with the wave form spring 352 and compresses the spring to the position shown in FIG. 49A. In this position of the spring 352 the cord 356 is free to move in opposite directions through the locking mechanism 344. When the button 360 is released, the spring 352 moves upwardly from its position shown in FIG. 49A and portions of the spring 362 engage with the cord portion 356 extending through the locking mechanism channel 346 and hold the cord portion against the ridges 348 at the top of the channel 346. This locks the cord portion 356 in the locking mechanism 344.

FIGS. 50A and 50B show a further embodiment of a one-way cord locking mechanism. The mechanism includes a housing 364 having a hole 366 extending through the housing that is defined by a cone-shaped interior surface 368. A pair of lock members 370, 372 are positioned in the housing hole 366. Each of the lock members 370, 372 have exterior surfaces 374, 376 that when the locking members are positioned together, define a truncated cone shape that fits within the cone-shaped interior surface 368 of the housing 364. The opposing interior surfaces 378, 380 of the lock members 370, 372 are formed with mating peaks and valleys. As shown in FIG. 50B, a spring 382 biases the two lock members 370, 372 into the cone-shaped interior surface 368 of the housing 364, thereby causing the lock member interior surfaces 378, 380 to move toward each other. A portion of a cord length 384 extending through the opposing interior surfaces 378, 380 of the lock members 370, 372 is prevented from moving in the upward direction as shown in FIG. 50B due to the bias of the spring 382. However, when the cord portion 384 is moved in the opposite downward direction as shown in FIG. 50B, the movement of the cord portion 384 causes the lock members 370, 372 to compress the spring 382. This allows the lock

member interior surfaces **378**, **380** to move away from each other and release the portion of the cord **384** for movement through the lock mechanism.

FIGS. **51A-51E** show one method of inserting the apparatus of the invention into the tubular insertion device **86** described earlier. As shown in these drawing figures, a length of suture **386** is looped around the apparatus and is then pulled through the interior of the insertion device **86**. The first **14** and second **22** cord segments are folded flat against each other and the additional cord segment **38** is folded over parallel with the first cord segment **14** and second cord segment **22**. The apparatus is then pulled by the suture loop **386** into the interior of the insertion device **86** to the position shown in FIG. **51E**.

FIGS. **52A** and **52B** show a further embodiment of an insertion device **390**. The insertion device **390** has the configuration of an elongate narrow rod with a pair of opposed grooves **392**, **394** extending up one side of the rod from a distal end **396** of the rod. A third groove **398** is formed in a side of the rod toward a proximal end of the rod. The third groove **398** is positioned between the opposed pair of grooves **392**, **394**. According to the method of using the insertion device **390**, the first cord segment **14** and second cord segment **22** of the apparatus **12** are positioned in the opposed pair of grooves **392**, **394** that extend from the insertion device distal end **396**. The additional cord segment **38** of the apparatus **12** is positioned in the third groove **398** in the side of the rod. With the cords of the apparatus held in these grooves, the insertion device **390** is then inserted through a cannula **44** to insert the apparatus **12** into the abdominal cavity.

FIG. **53** shows a representation of a further embodiment of the insertion device **402** that is similar in construction to the previously-described embodiment of the insertion device **390**. The insertion device **402** of FIG. **54** is also comprised of a pair of opposed grooves **404**, **406** that receive the first **14** and second **22** cord segments of the apparatus **12**, and a third groove **408** that receives the additional cord segment **38** of the apparatus.

FIG. **54** shows a still further embodiment of an insertion device **410**. The insertion device **410** has a rod-shaped length with a hollow distal end. The rod distal end is comprised of a first half **412** and a second half **414** that are connected together by a living hinge assembly **416**. According to the method of using the insertion device **410** of FIG. **54**, the apparatus **12** is positioned in the interior of the first half **412** with the first cord segment **14** and second cord segment **22** extending parallel to each other, and the third cord segment **38** folded over the first cord segment **14** and second cord segment **22**. The second half **414** of the insertion device is then folded over the hinge assembly **416** and snapped closed to prepare the insertion device **410** for insertion of the apparatus **12**.

FIGS. **55A-55C** show a mesh apparatus **420** that is designed to be used as a part of the apparatus of the invention. The mesh apparatus **420** is basically comprised of a generally rectangular or trapezoidal-shaped panel of surgical mesh **422** with a pair of axially aligned tubes **424** at one side and a pair of axially aligned tubes **426** at the opposite side. As shown in FIG. **55B**, the mesh apparatus **420** can be rolled up around the pairs of tubes **424**, **426** to reduce the size of the apparatus for insertion through a cannula and into the abdominal cavity. FIG. **55C** shows the mesh apparatus **420** positioned in the abdominal cavity **46** and held in place against the first internal organ **48** by one of the previously-described embodiments of the apparatus. It should be understood that any of the previously-described embodiments of the apparatus may be employed according to the method of the invention to hold the surgical mesh **420** in its position as shown in FIG. **55C**.

As various modifications could be made in the constructions of the apparatus and the methods herein described and illustrated without departing from the scope of the invention, it is intended that all matter contained in the foregoing description or shown in the accompanying drawings shall be interpreted as illustrative rather than limiting. Thus, the breadth and scope of the present invention should not be limited by any of the above-described exemplary embodiments, but should be defined only in accordance with the following claims appended hereto and their equivalents.

What is claimed is:

1. A method of intra-abdominally moving a first internal organ to a position away from a second internal organ and then holding the first internal organ at the position without manual input, the method comprising:

providing a first cord segment having a flexible length with opposite ends and a second cord segment having a flexible length with opposite ends;

inserting the first and second cord segments through an abdominal wall and into an abdominal cavity containing the first and second internal organs;

connecting one end of the first cord segment to tissue adjacent the first internal organ and on an opposite side of the first internal organ from the abdominal wall and connecting the other end of the first cord segment to the abdominal wall with the length of the first cord segment engaging across and moving the first internal organ toward the position away from the second internal organ;

connecting one end of the second cord segment to tissue adjacent the first internal organ and on an opposite side of the first internal organ from the abdominal wall and connecting the other end of the second cord segment to the abdominal wall with the length of the second cord segment engaging across and moving the first internal organ toward the position away from the second internal organ;

whereby the first and second cord segments engaging across the first internal organ hold the first internal organ at the position away from the second internal organ without manual input.

2. The method claim 1, further comprising:

the first internal organ being a human liver and the second internal organ being a human stomach.

3. The method of claim 1, further comprising:

providing the first and second cord segments as parts of a single cord with one end of the first cord segment being connected to the one end of the second cord segment.

4. The method of claim 1, further comprising:

providing the first and second cord segments as parts of a single cord with the other end of the first cord segment being attached to the other end of the second cord segment by a third cord segment having a flexible length that extends between the other ends of the first and second cord segments.

5. The method claim 4, further comprising:

attaching the one end of the first cord segment to the one end of the second cord segment by tying a knot between the one end of the first cord segment and the one end of the second cord segment.

6. The method of claim 1, further comprising:

providing a tissue connector at the one end of the first cord segment and the one end of the second cord segment and

19

using the tissue connector to connect both the one end of the first cord segment and the one end of the second cord segment to the tissue.

7. The method of claim 6, further comprising:
providing a further tissue connector at the other end of the 5
first cord segment and using the further tissue connector
to connect the other end of the first cord segment to the
abdominal wall.

20

8. The method of claim 7, further comprising:
providing a still further tissue connector at the other end of
the second cord segment and using the still further tissue
connector to connect the other end of the second cord
segment to the abdominal wall.

* * * * *

专利名称(译)	用于腹腔内移动第一内部器官到远离第二内部器官的位置然后将第一内部器官保持在该位置而无需手动输入的装置和方法		
公开(公告)号	US8251889	公开(公告)日	2012-08-28
申请号	US13/203396	申请日	2010-02-25
[标]申请(专利权)人(译)	SCOTT J STEPHEN		
申请(专利权)人(译)	SCOTT J. STEPHEN		
当前申请(专利权)人(译)	MIS SOLUTIONS , INC.		
[标]发明人	SCOTT J STEPHEN		
发明人	SCOTT, J. STEPHEN		
IPC分类号	A61B1/32		
CPC分类号	A61B17/0218 A61B17/0401 A61B17/04 A61B17/06109 A61B2017/0225 A61B2017/0417 A61B2017/0427 A61B2017/00805 A61B2017/0451 A61B2017/0464 A61B2017/045 A61B17/02 A61B17/0487 A61B2017/00818 A61B2017/0212		
其他公开文献	US20120078057A1		
外部链接	Espacenet USPTO		

摘要(译)

包括柔性长度的绳索和位于绳索的相对两端并且在绳索的中间位置处的三个组织连接器的设备被设计成通过腹腔镜插入腹壁并进入腹腔，并用于首先移动内部器官到远离第二内部器官的位置，其中该装置将第一内部器官保持在该位置而无需进一步手动输入，从而提供对第二内部器官的外科手术通路。

