



US 20190216505A1

(19) **United States**

(12) **Patent Application Publication**  
**Meade**

(10) **Pub. No.: US 2019/0216505 A1**

(43) **Pub. Date: Jul. 18, 2019**

(54) **UTERINE MANIPULATOR WITH CUTTING HEAD**

**Publication Classification**

(71) Applicant: **Freyja Healthcare, LLC**, North Andover, MA (US)

(51) **Int. Cl.**  
*A61B 17/42* (2006.01)  
*A61B 17/00* (2006.01)  
*A61B 90/30* (2006.01)

(72) Inventor: **John C. Meade**, North Andover, MA (US)

(52) **U.S. Cl.**  
CPC .... *A61B 17/4241* (2013.01); *A61B 17/00234* (2013.01); *A61B 2017/00557* (2013.01); *A61B 2017/4225* (2013.01); *A61B 90/30* (2016.02)

(21) Appl. No.: **16/368,457**

(22) Filed: **Mar. 28, 2019**

(57) **ABSTRACT**

**Related U.S. Application Data**

(63) Continuation of application No. PCT/US2018/047402, filed on Aug. 21, 2018.

A uterine manipulator can include a shaft including a first end, a second end, and embodiments of a cutting head configured and arranged to receive a cervix. The cutting head can be configured and adapted to be used to cut the tissue joining the vaginal wall to the cervix and uterus to facilitate removal of the uterus in a minimally invasive manner.

(60) Provisional application No. 62/548,252, filed on Aug. 21, 2017.

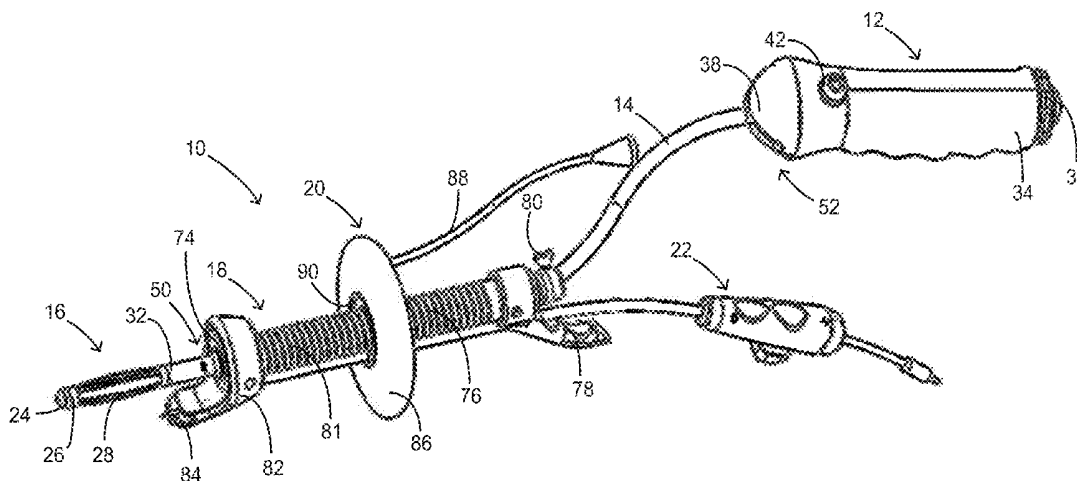





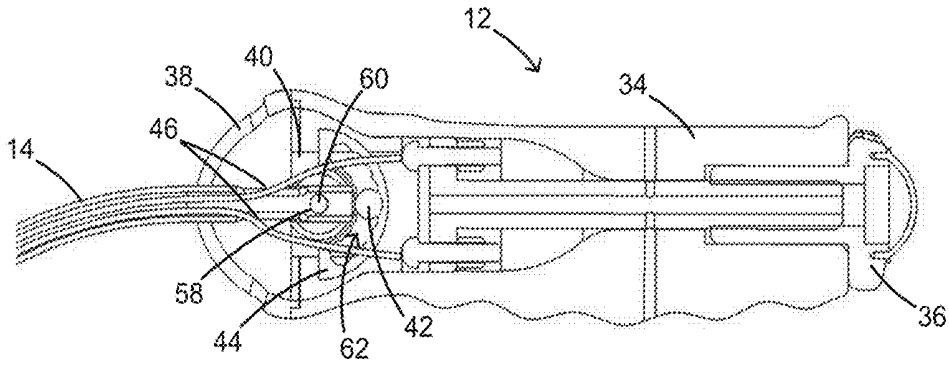

FIGURE 4A

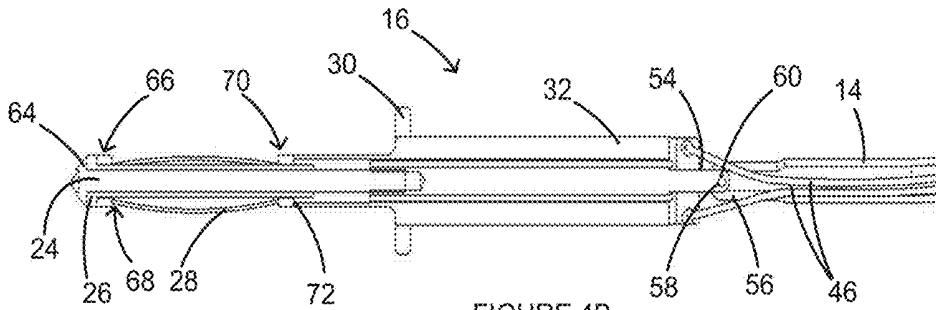

FIGURE 4B

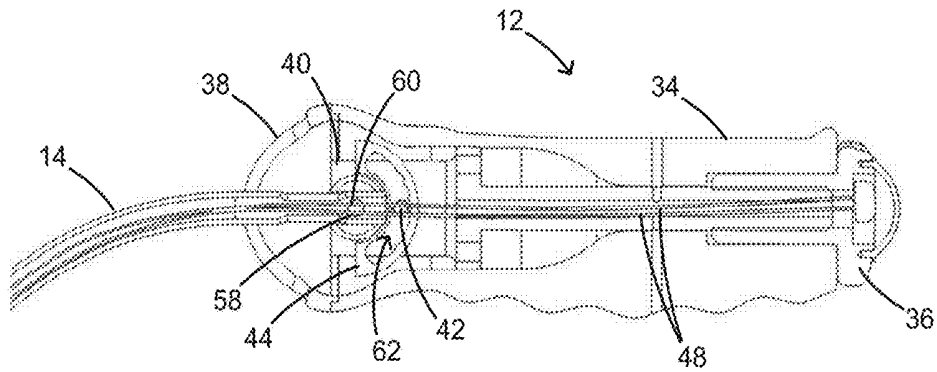

FIGURE 5A

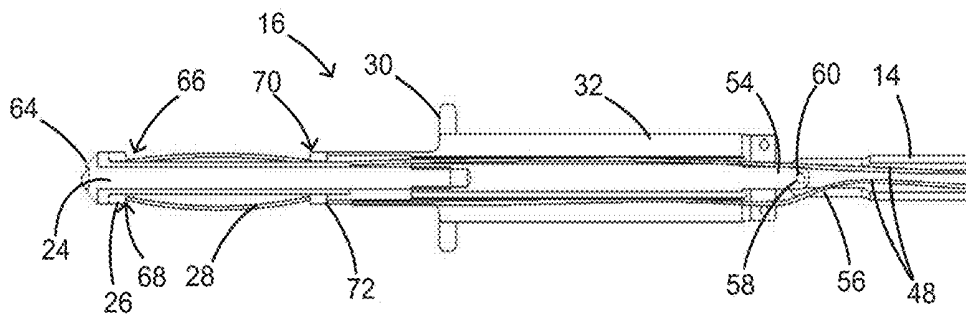

FIGURE 5B

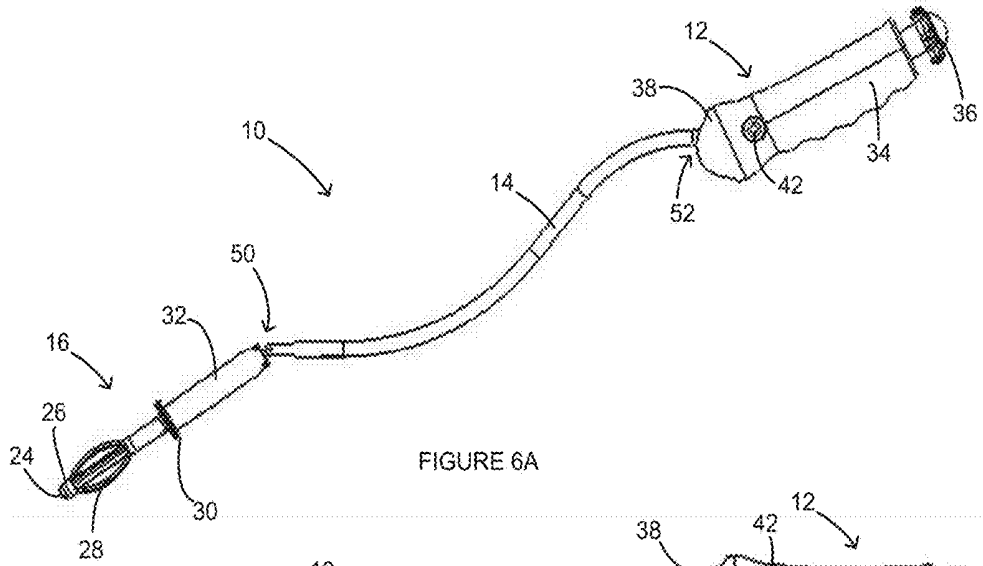

FIGURE 6A

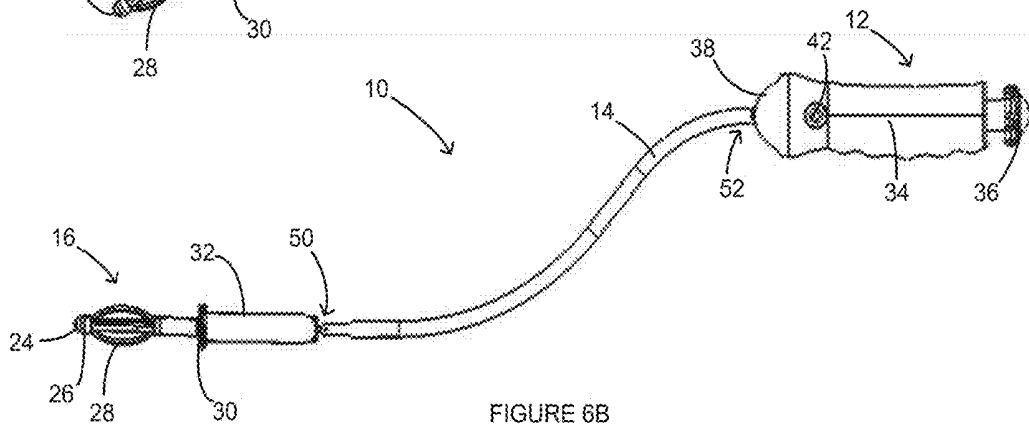

FIGURE 6B

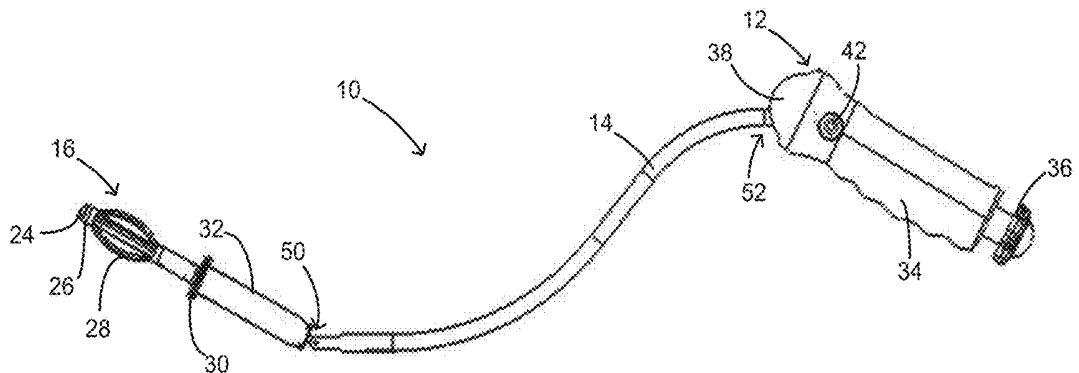

FIGURE 6C

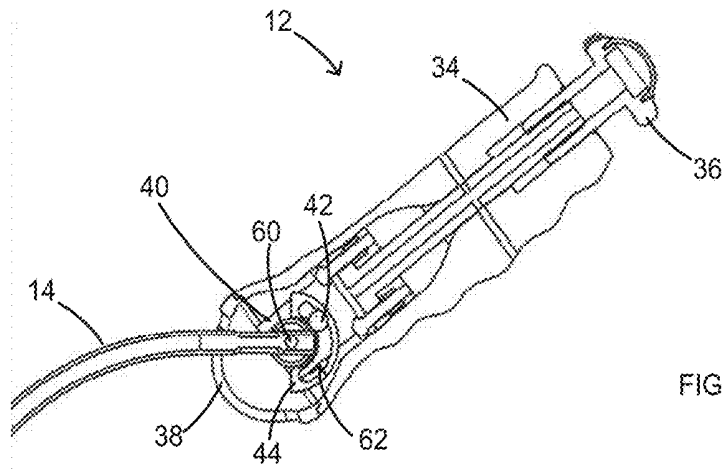

FIGURE 7A

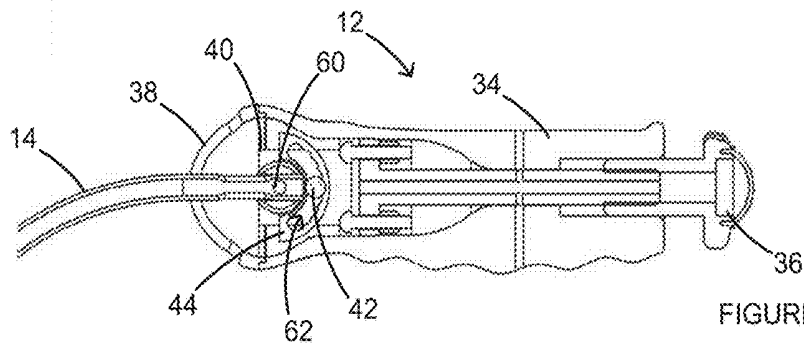

FIGURE 7B

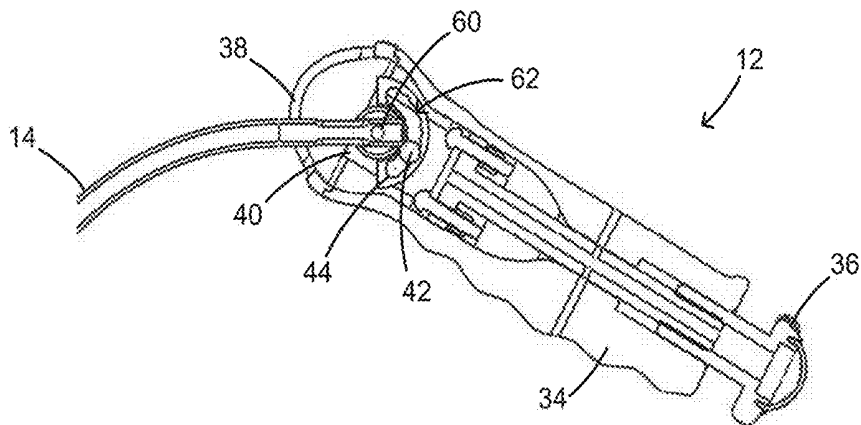

FIGURE 7C

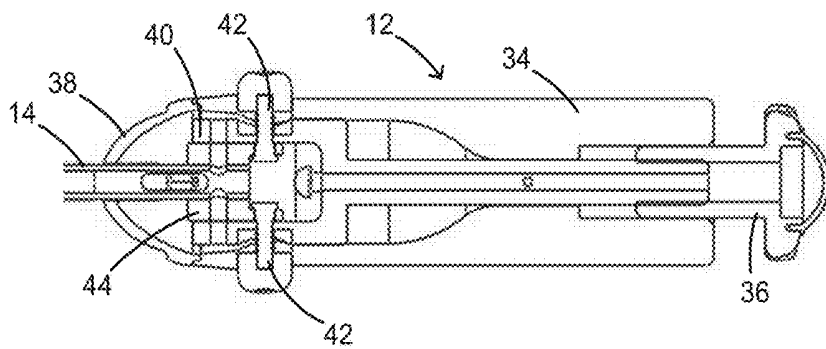

FIGURE 7D

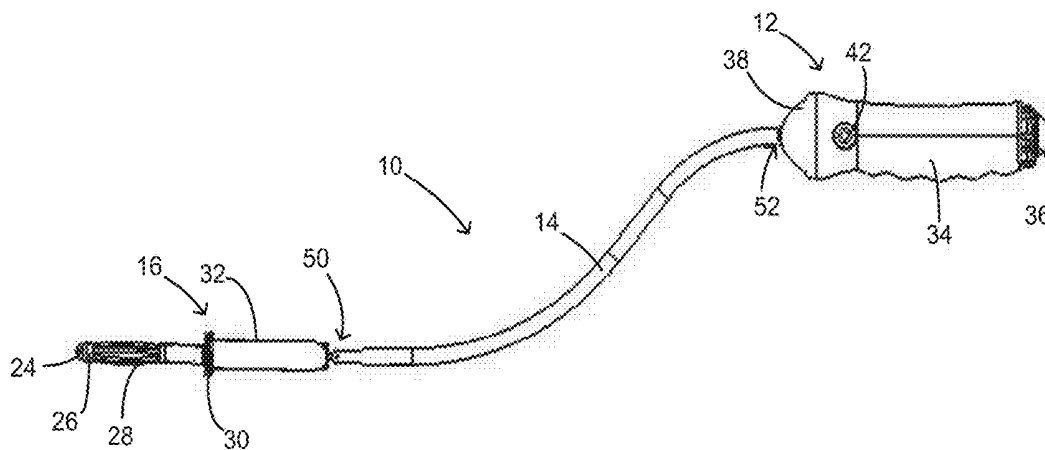

FIGURE 8A

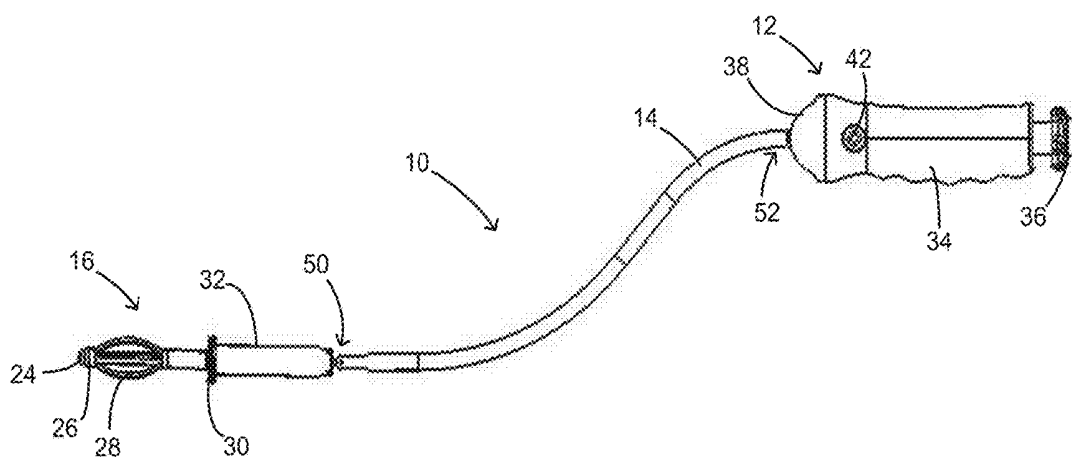
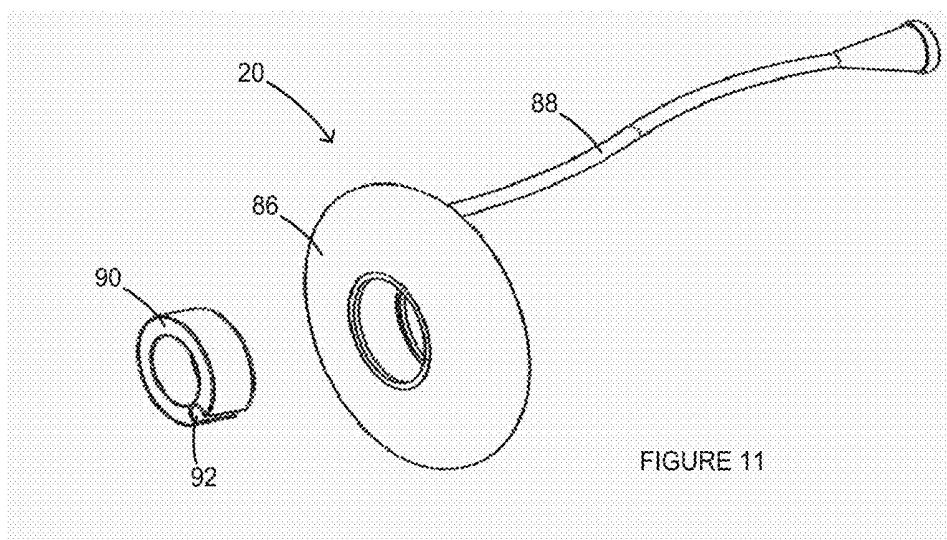
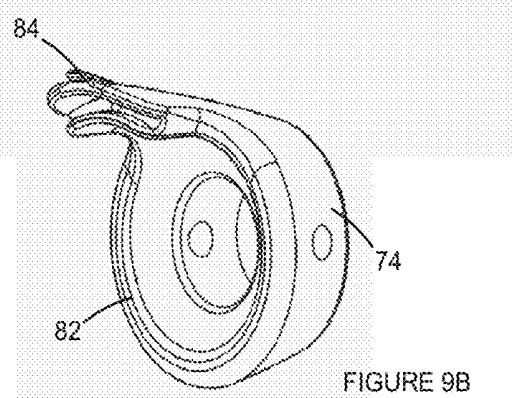
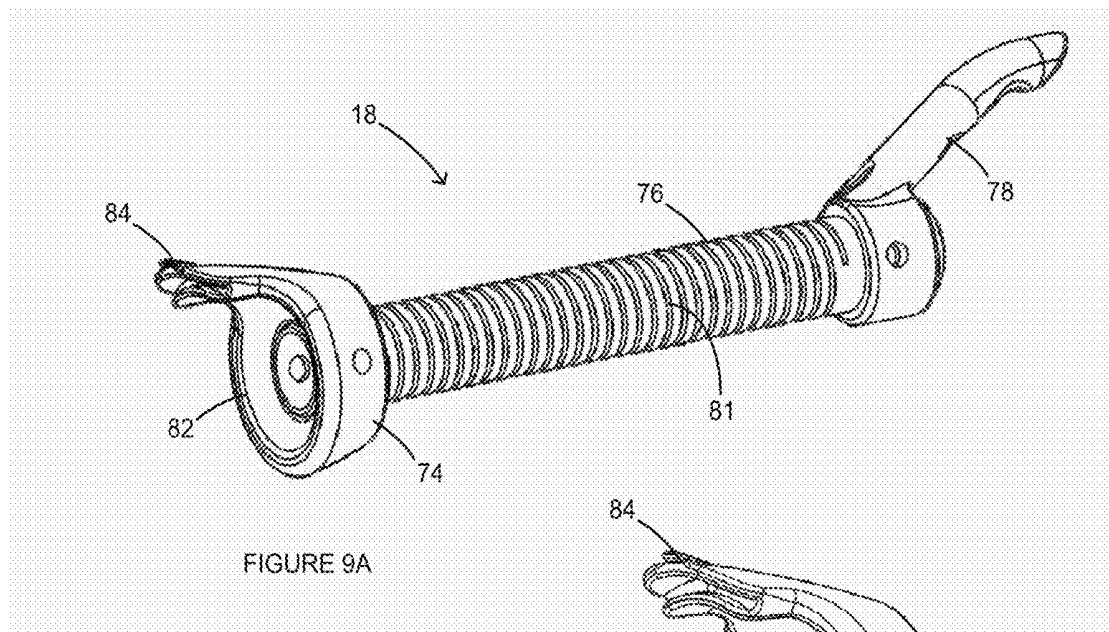

FIGURE 8B



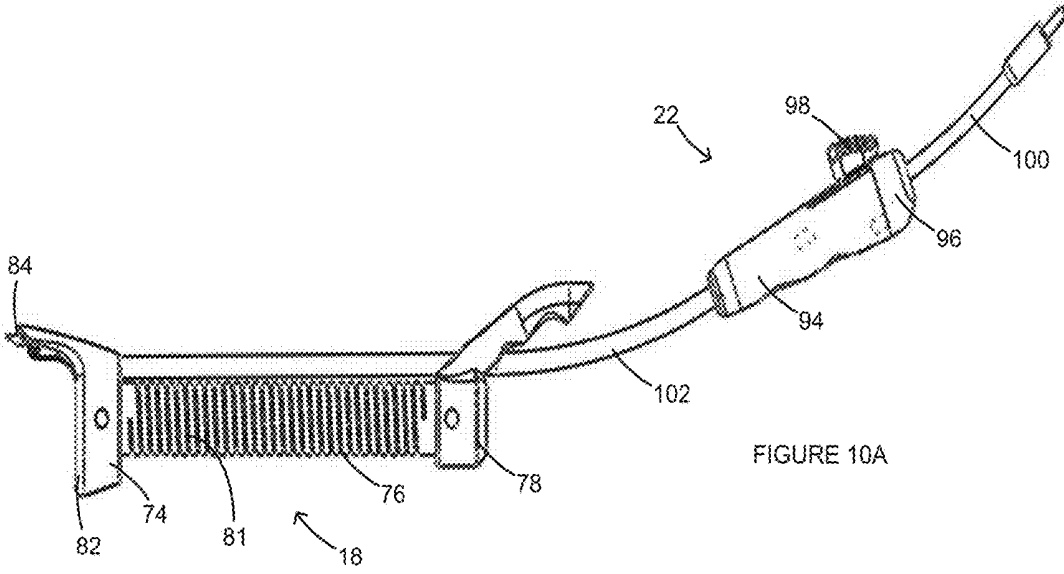

FIGURE 10A

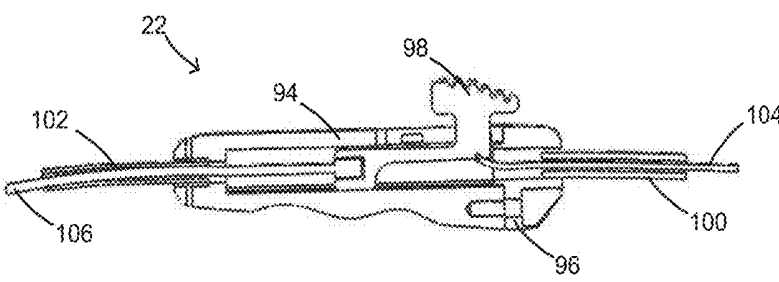
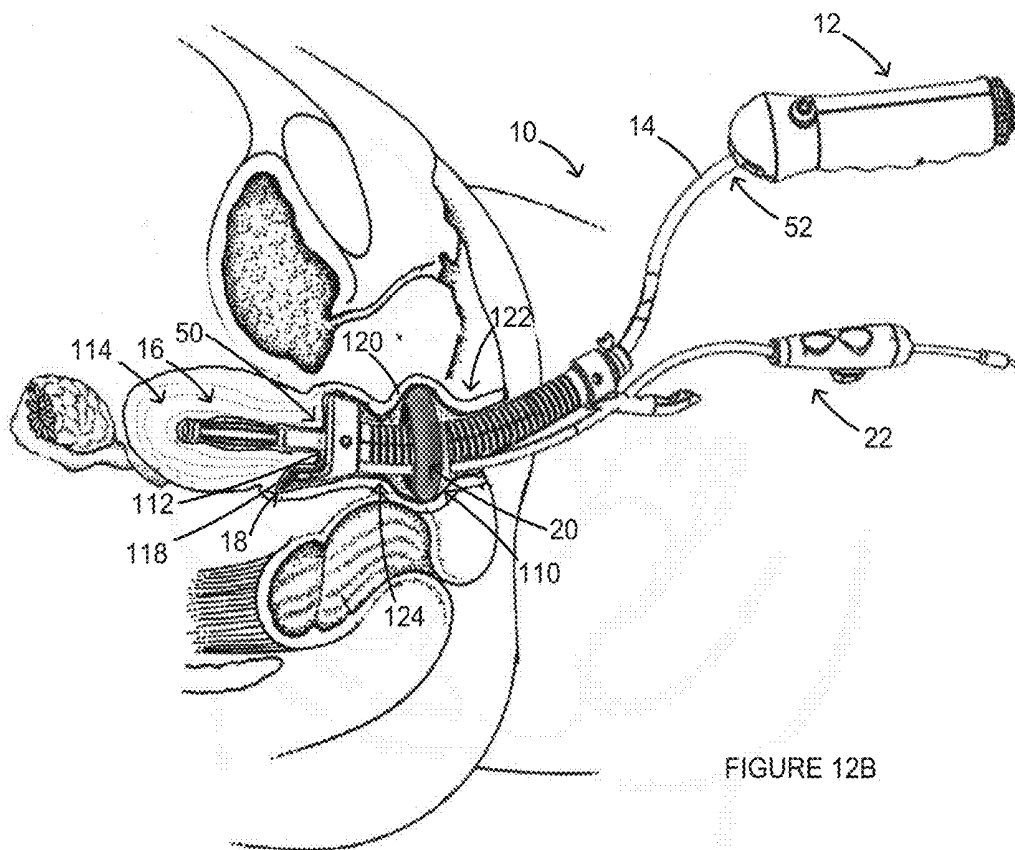
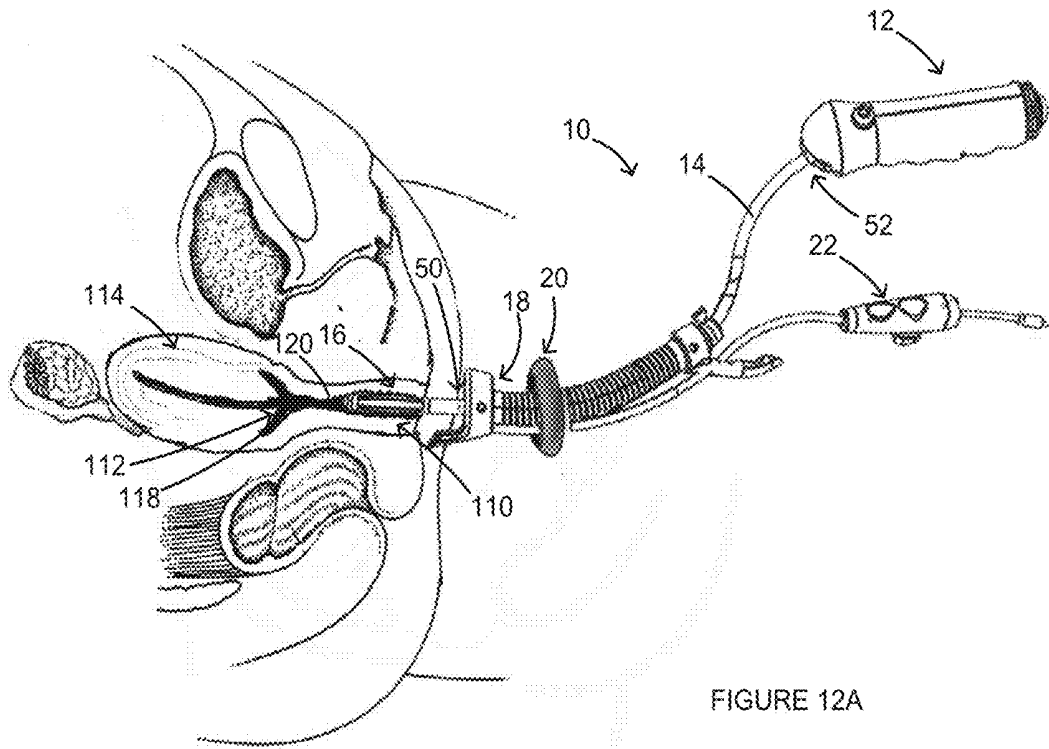
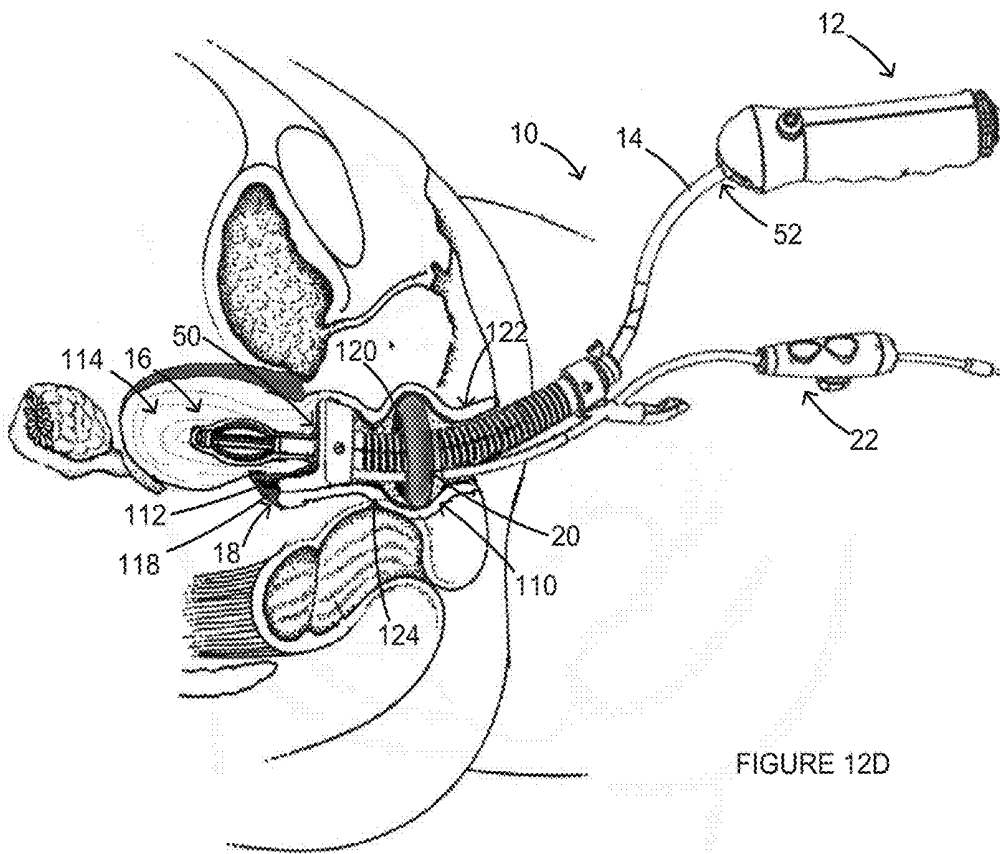
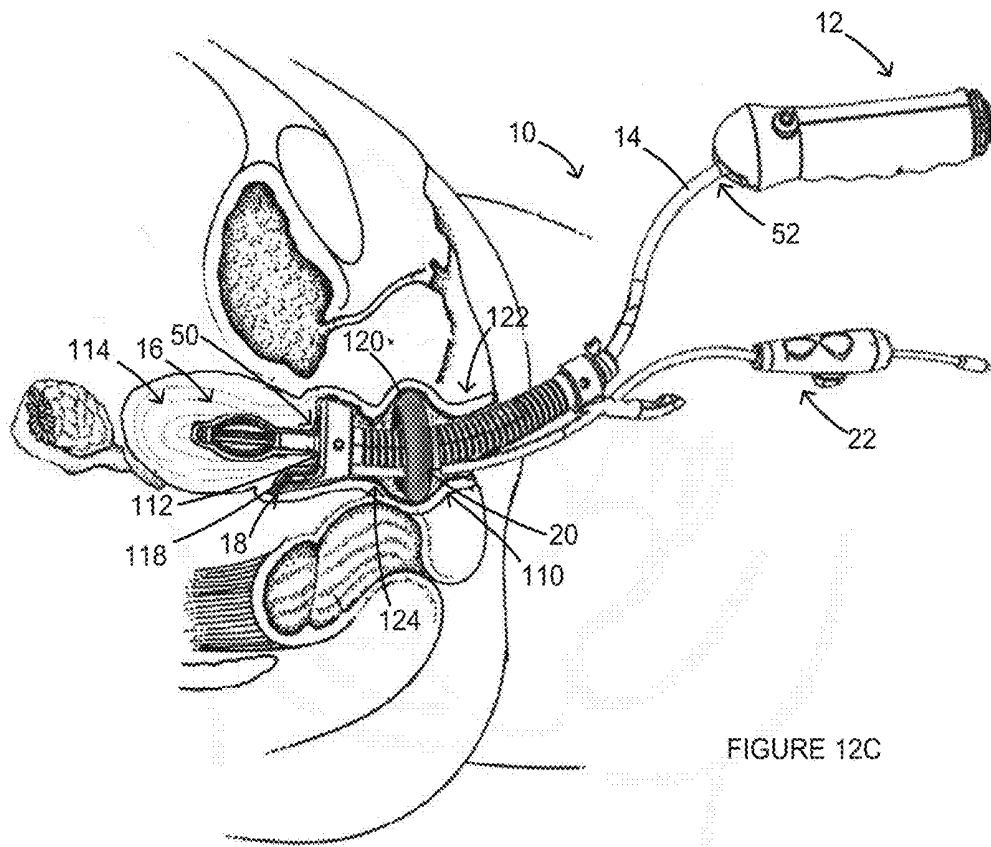

FIGURE 10B





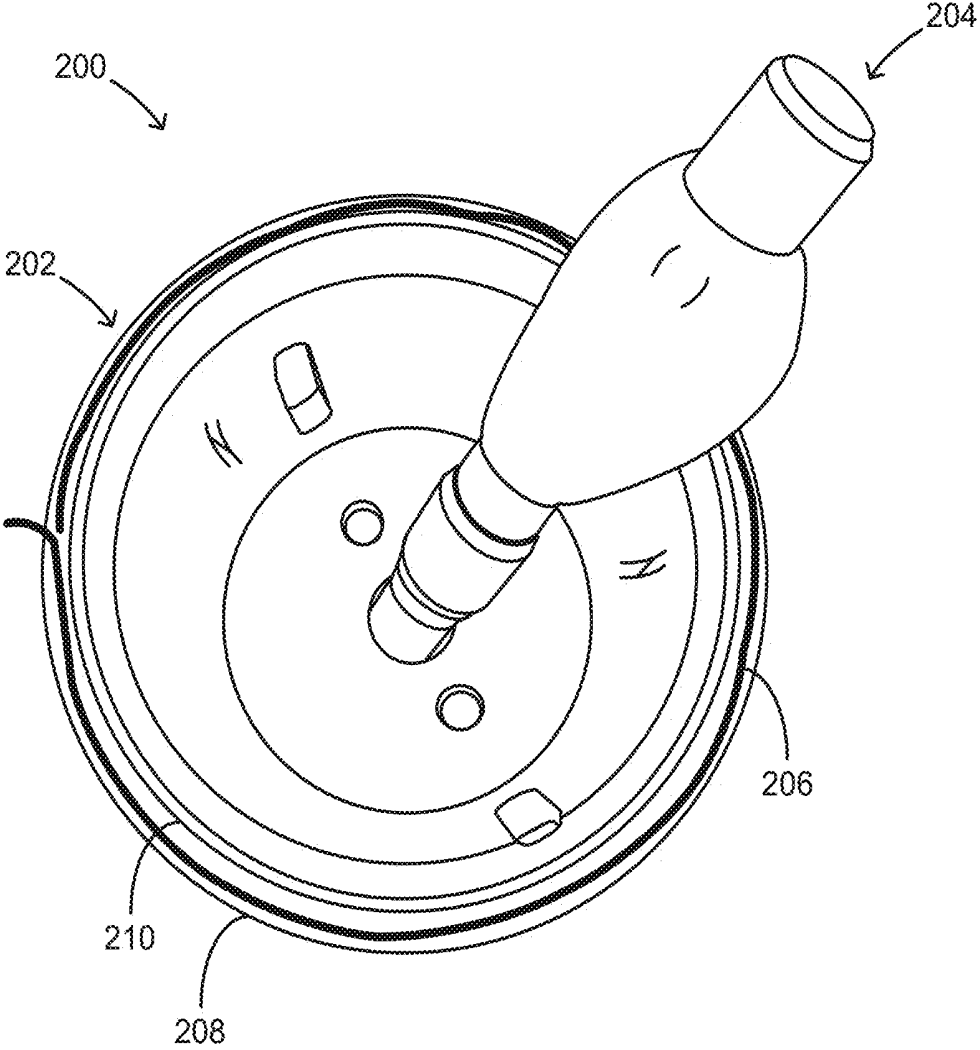

FIGURE 13

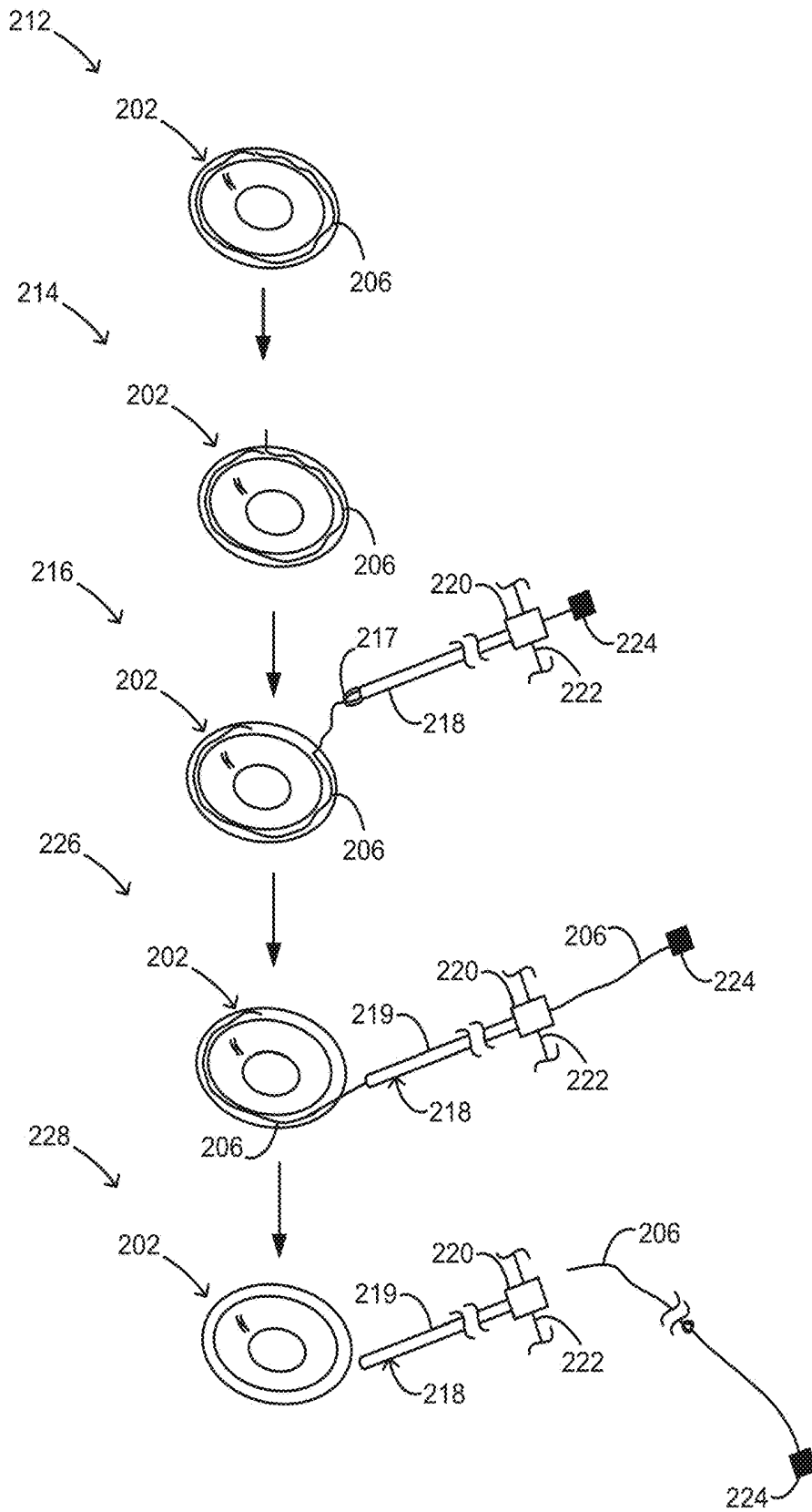
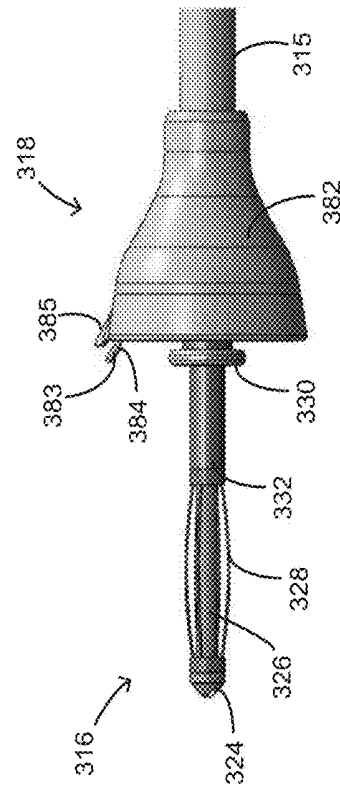
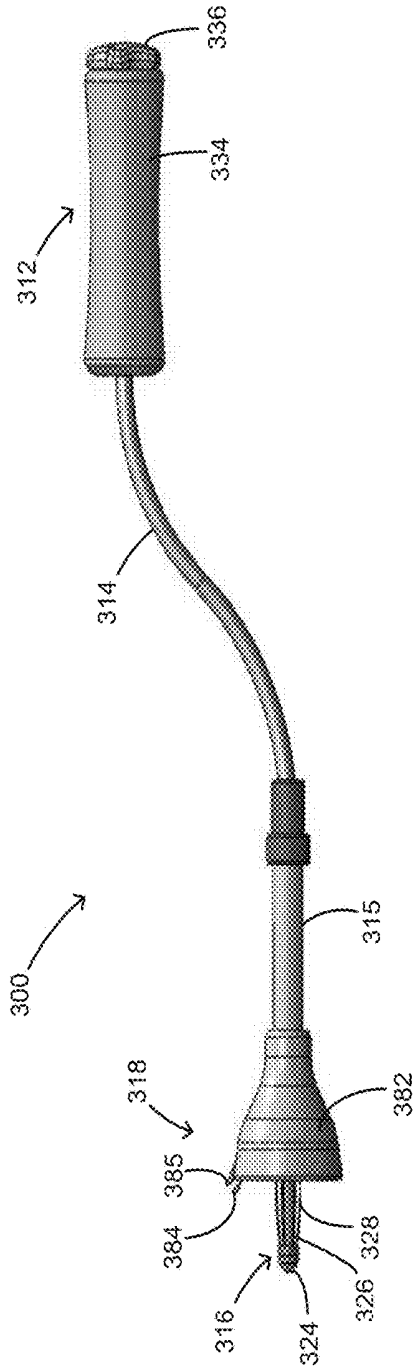

FIGURE 14



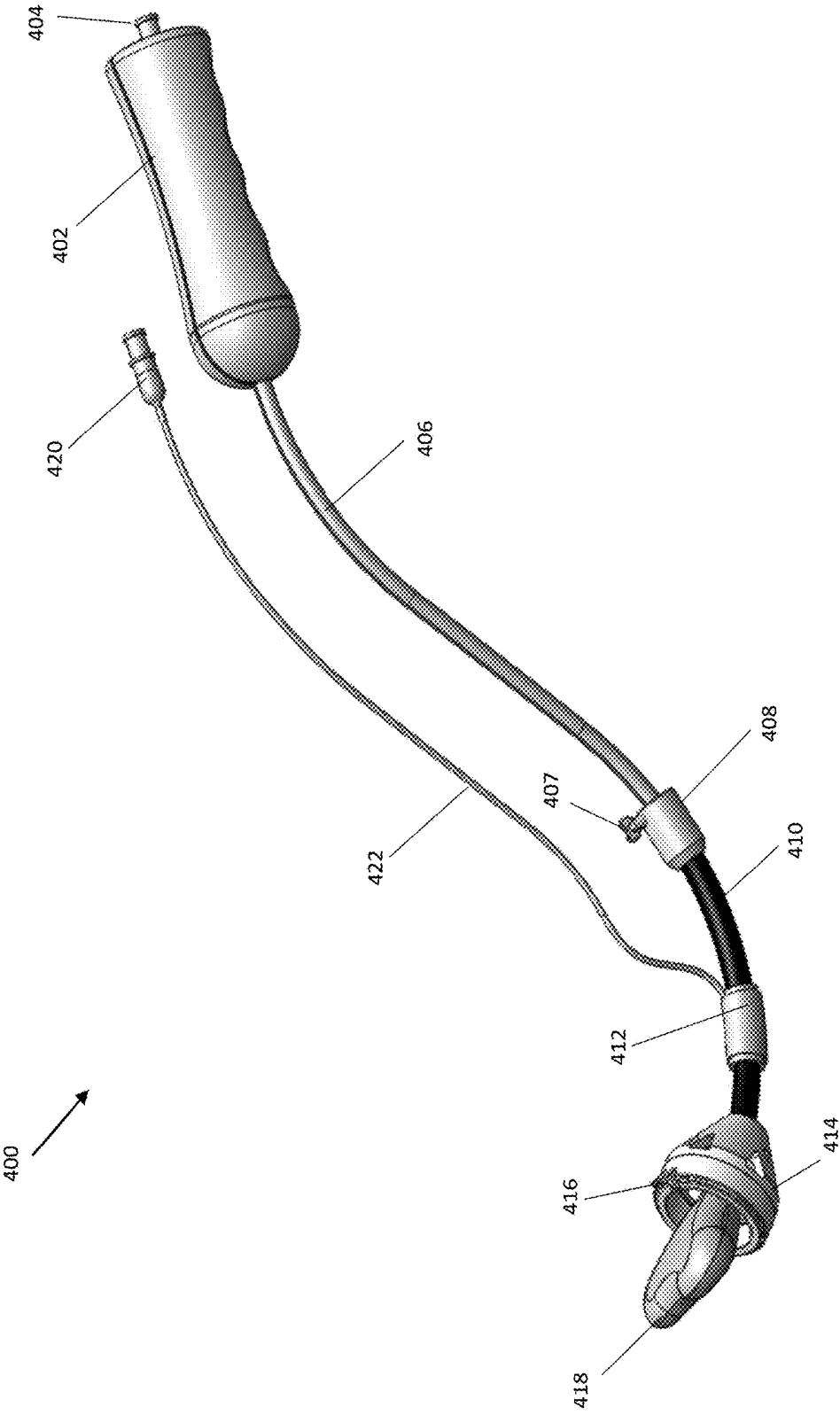

FIG. 16

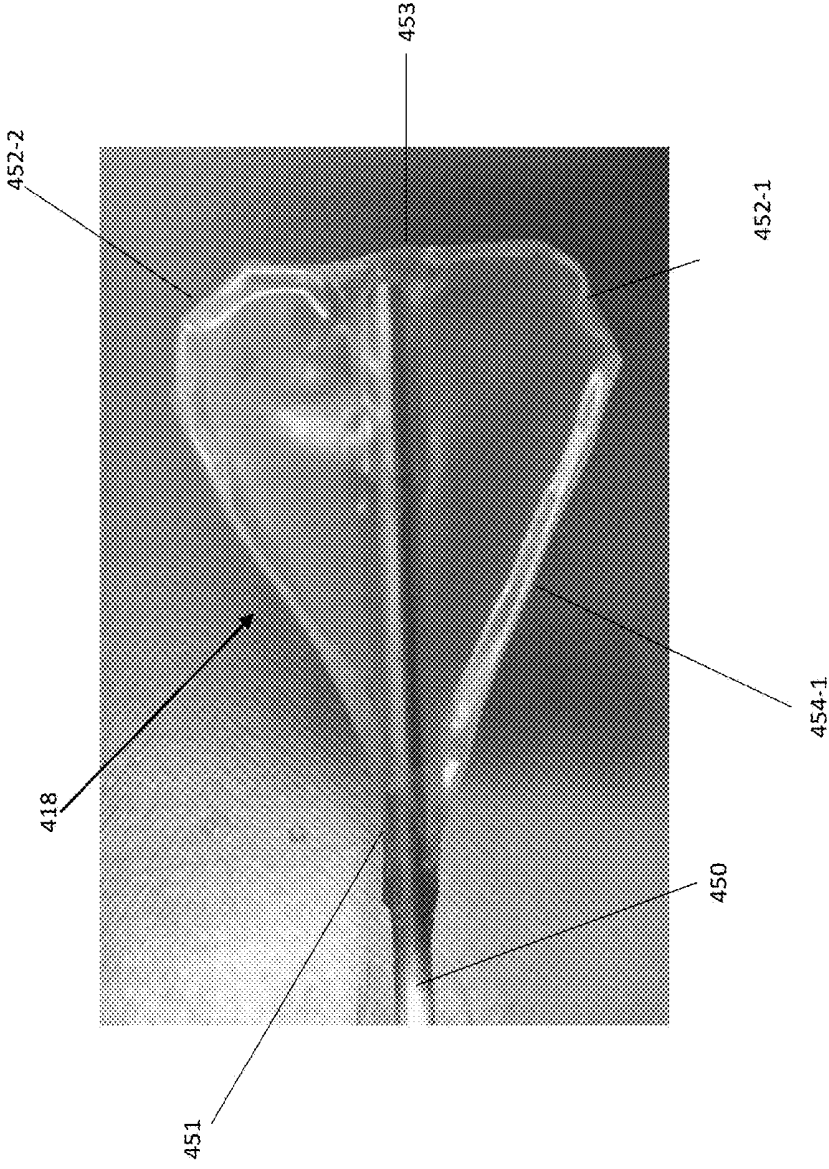

FIG. 17

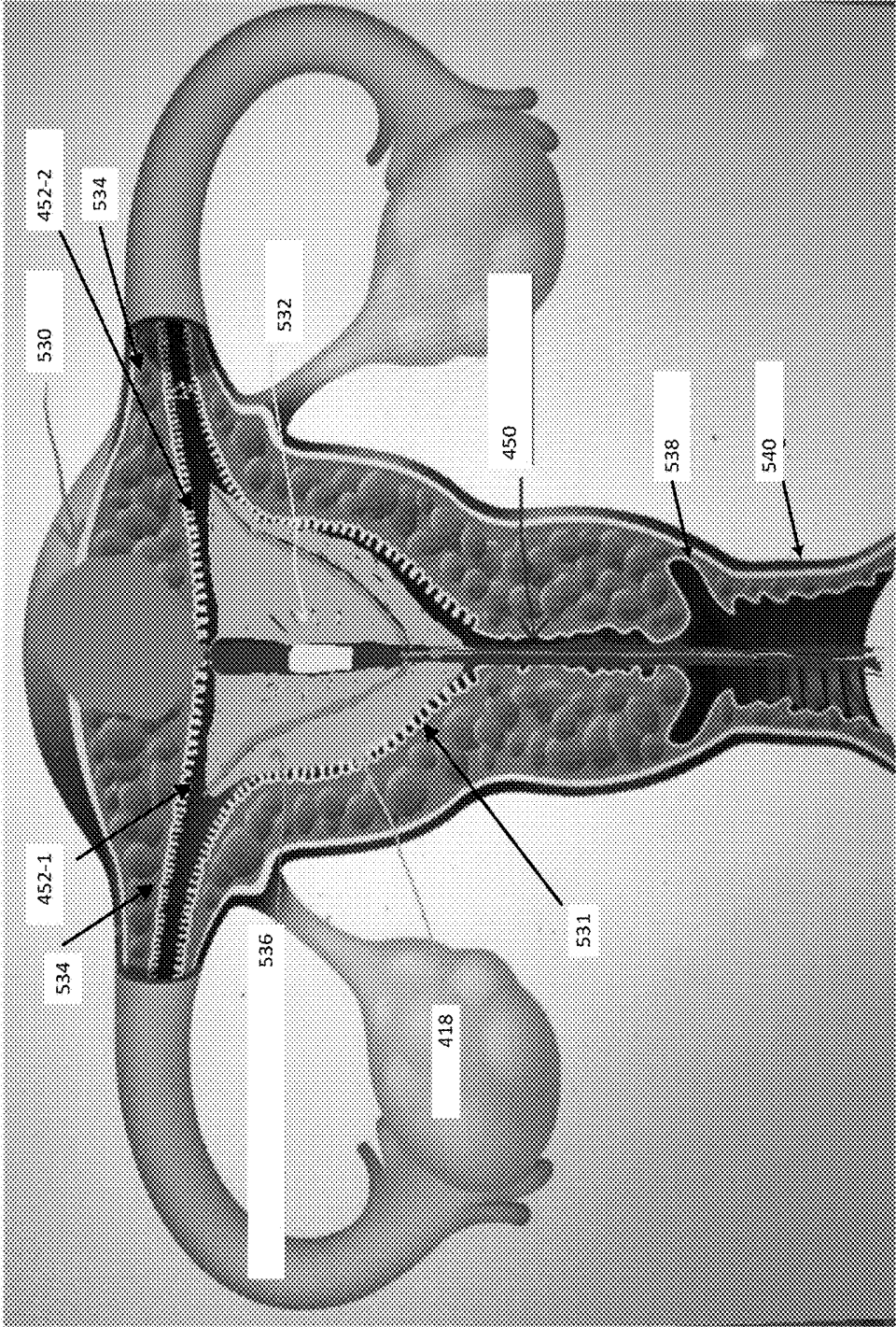

FIG. 18

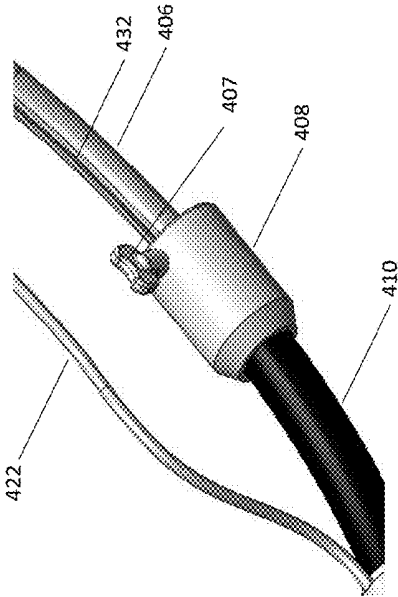

FIG. 19A

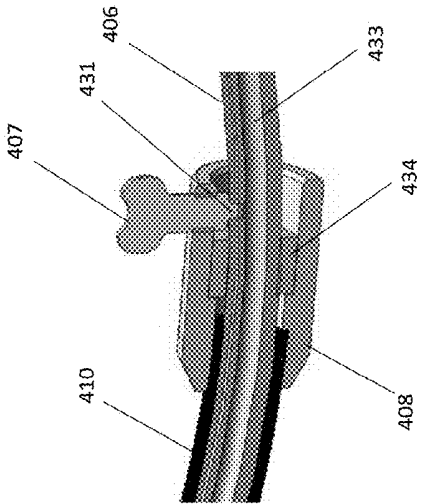

FIG. 19B

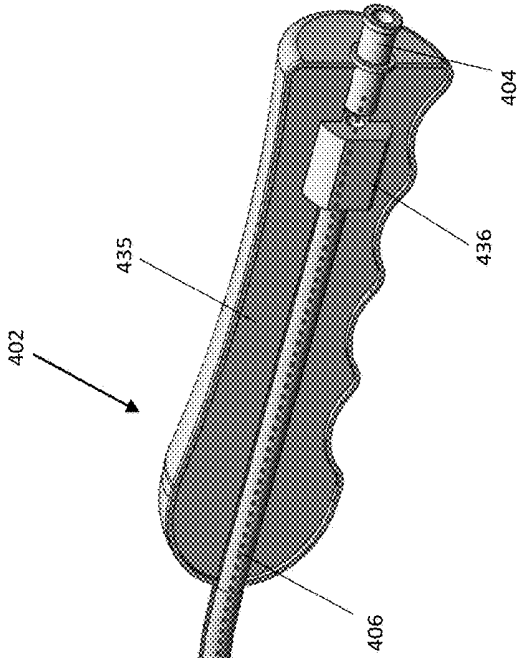

FIG. 20

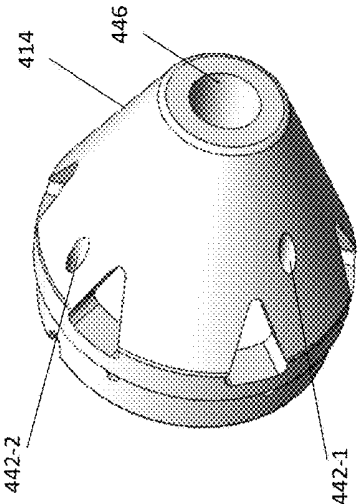

FIG. 21A

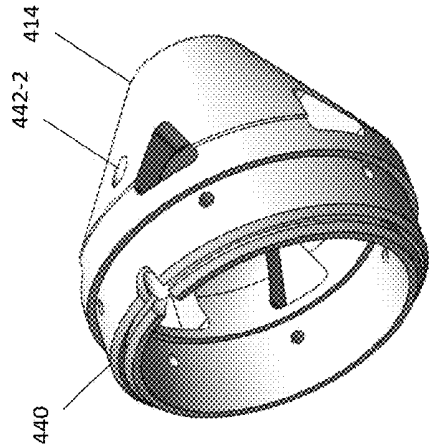

FIG. 21B

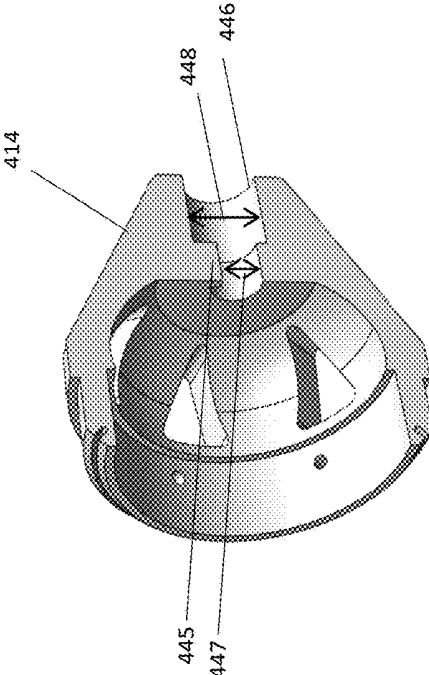

FIG. 21C

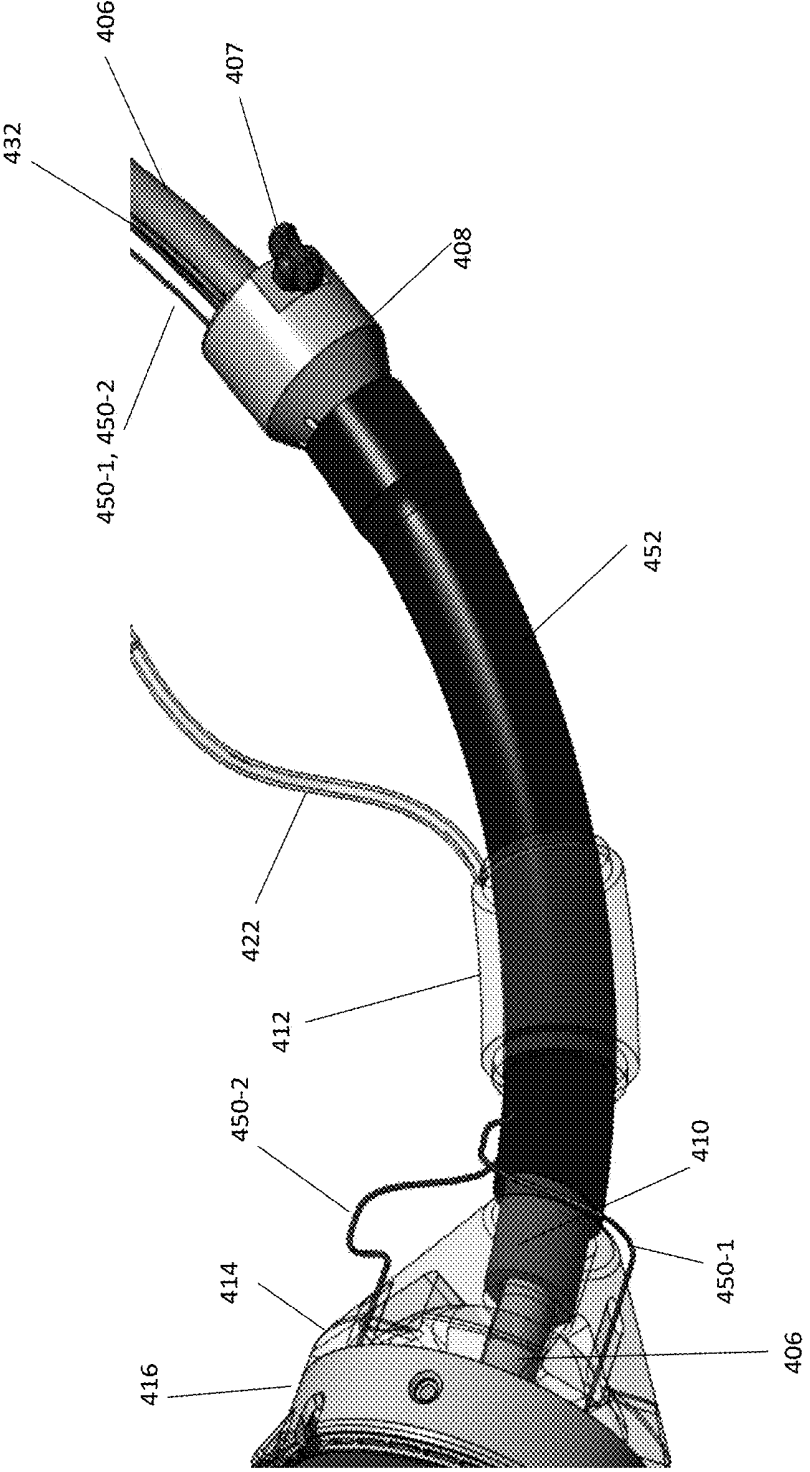

FIG. 22

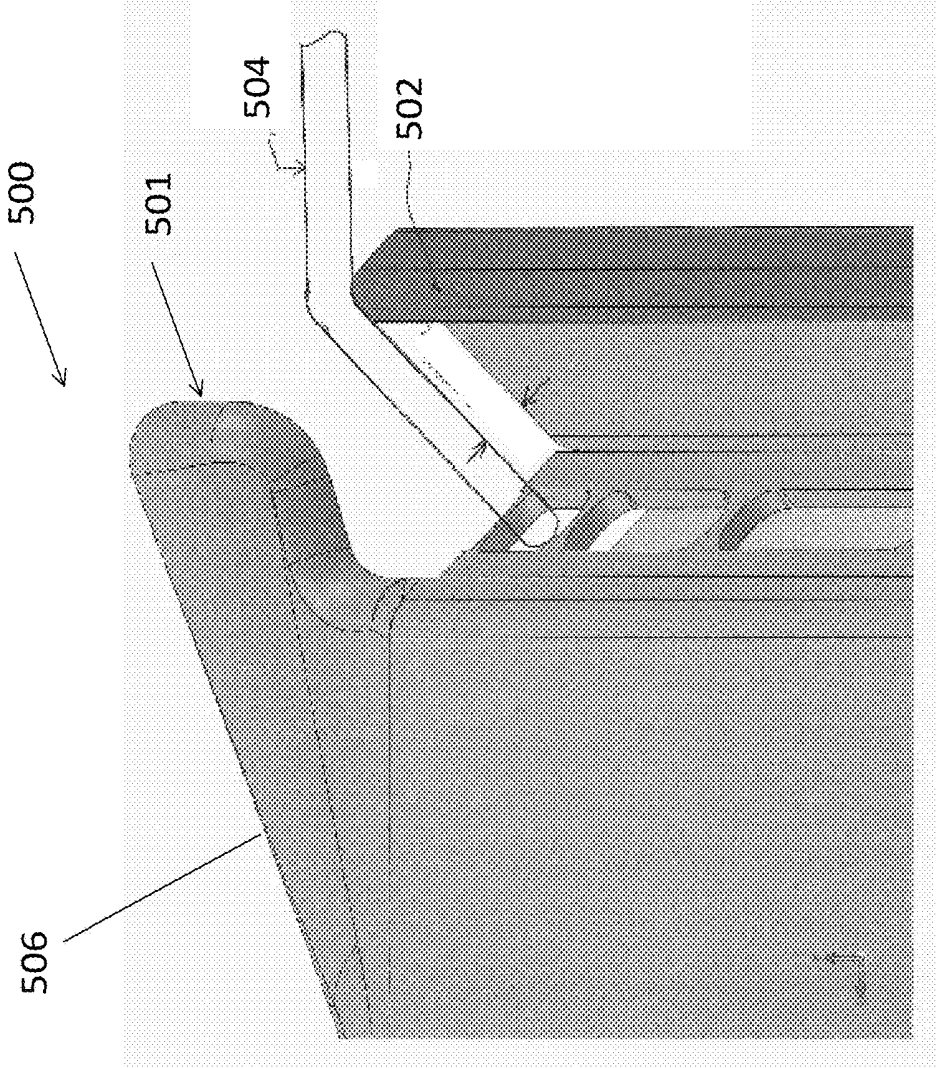

FIG. 23

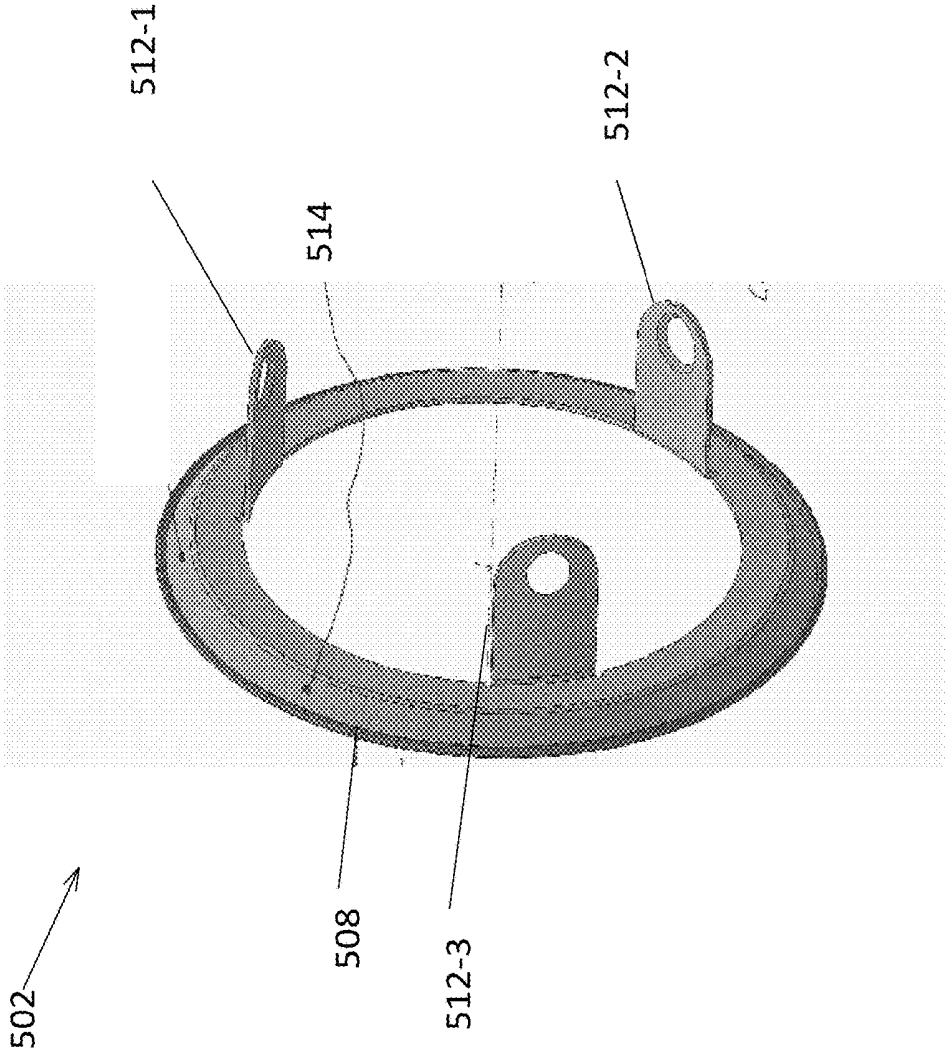

FIG. 24

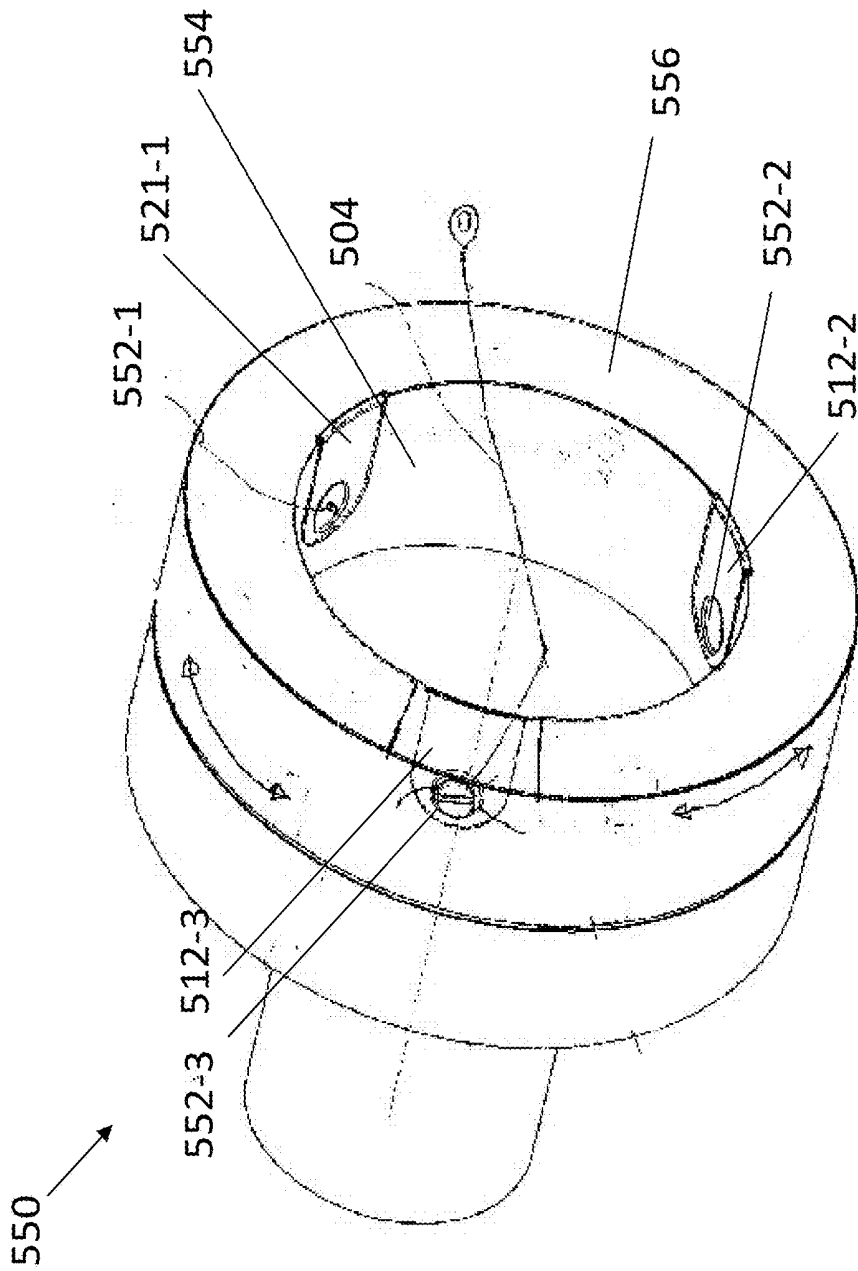

FIG. 25

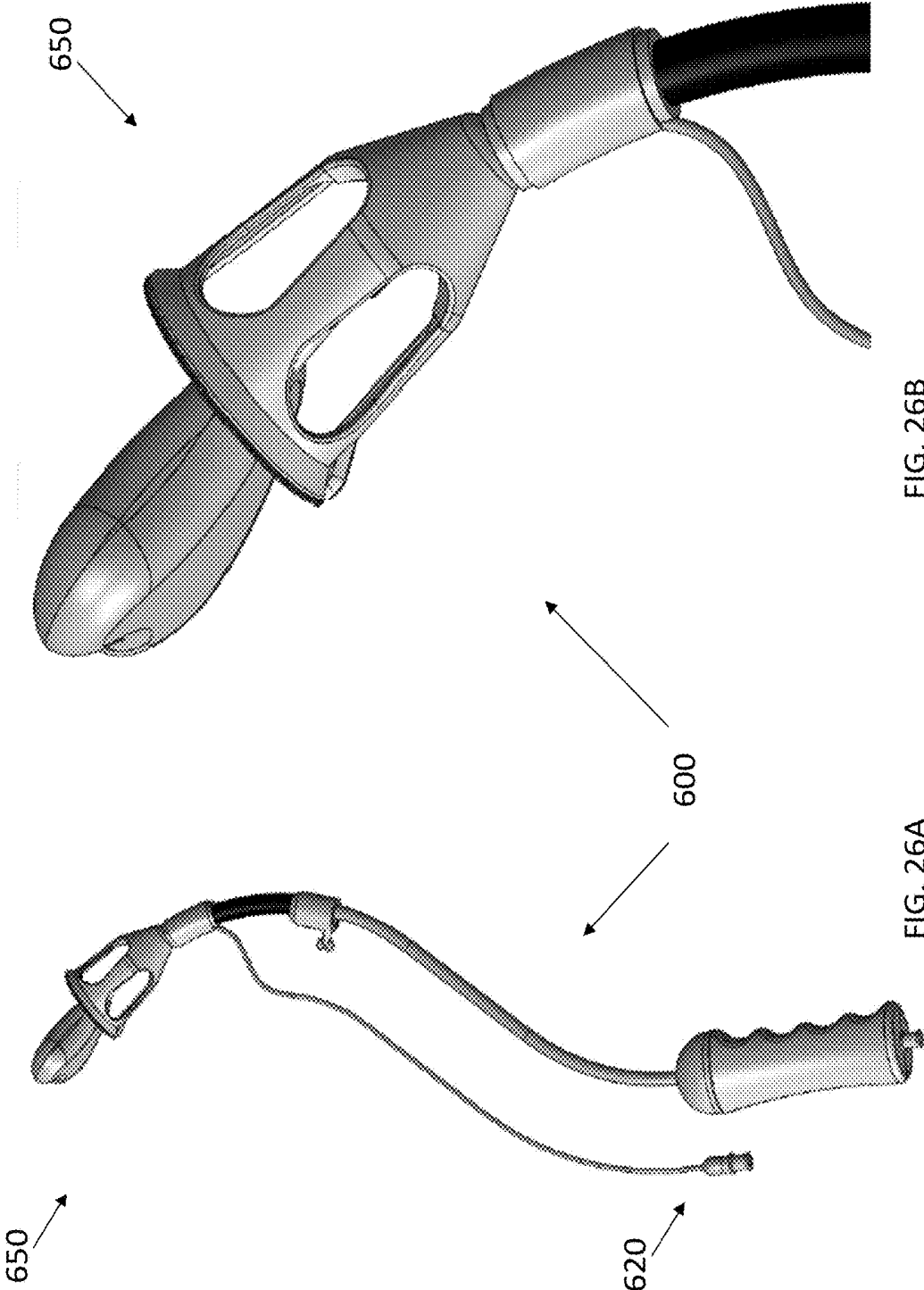
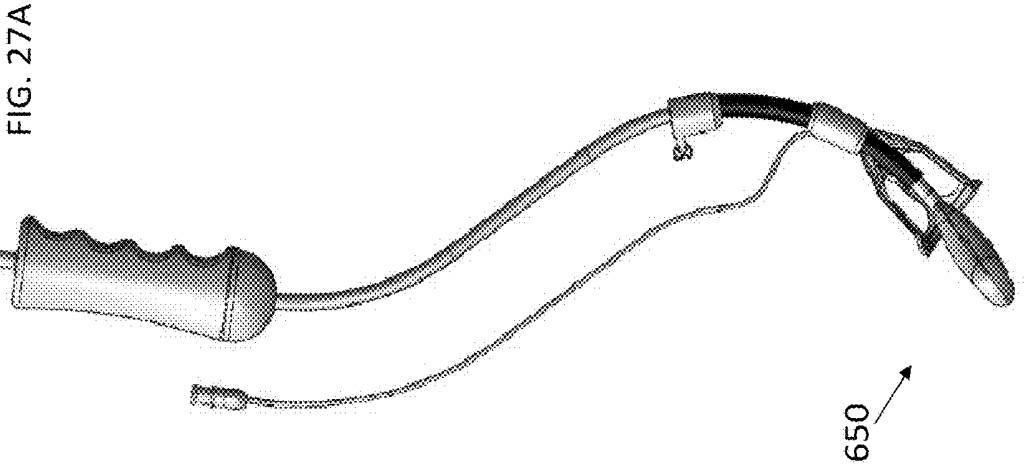
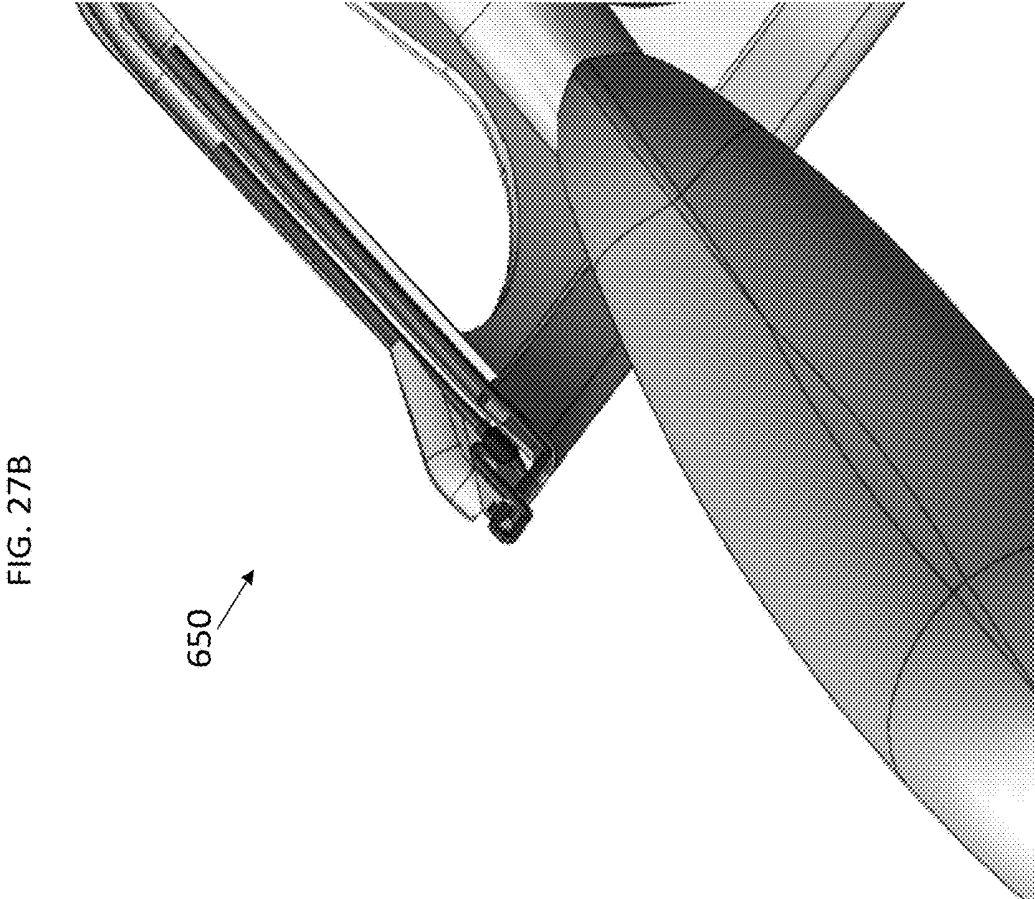

FIG. 26B

FIG. 26A



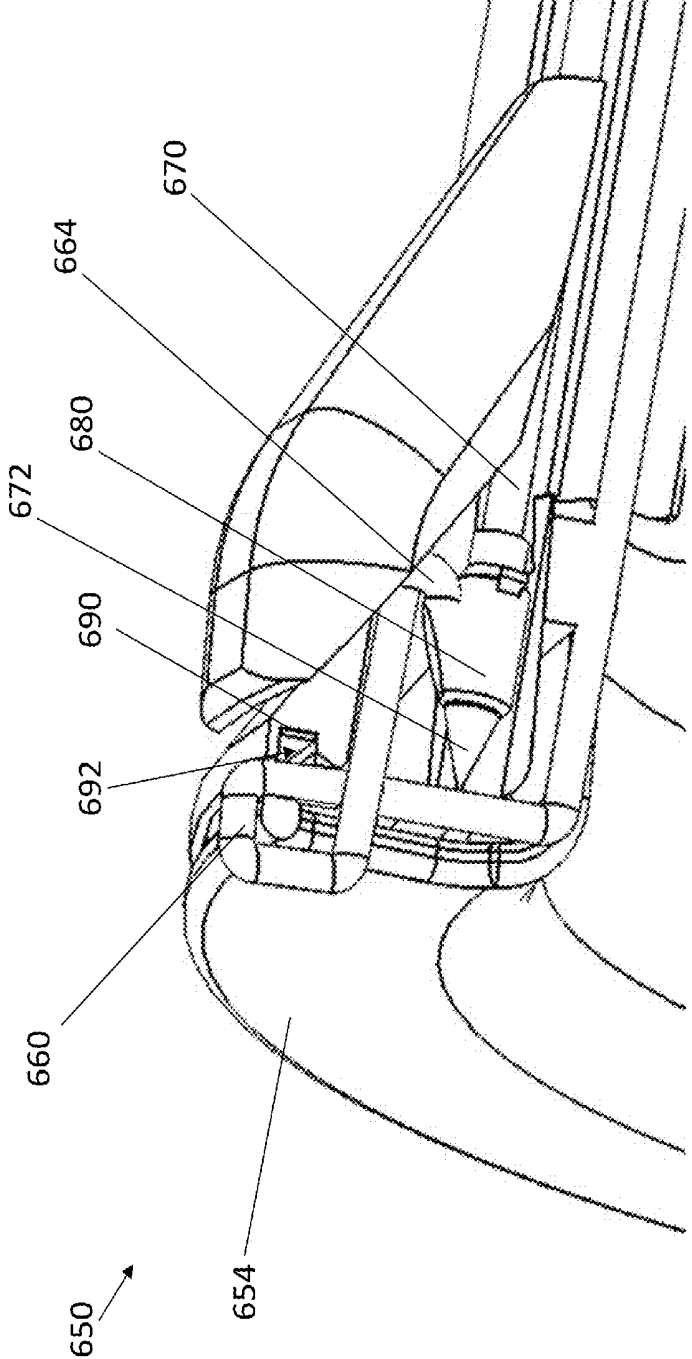

FIG. 28

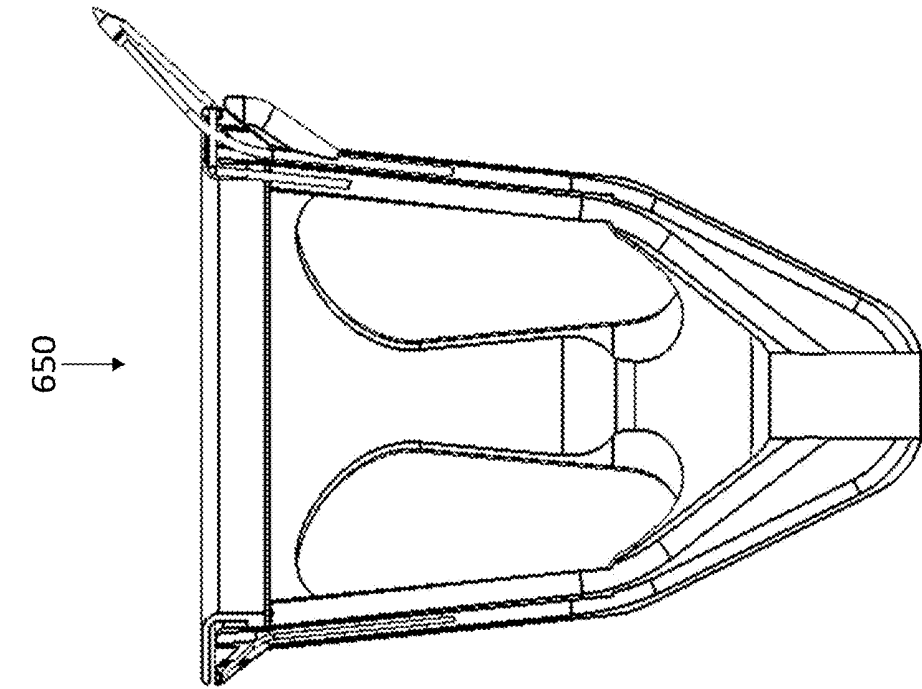

FIG. 29C

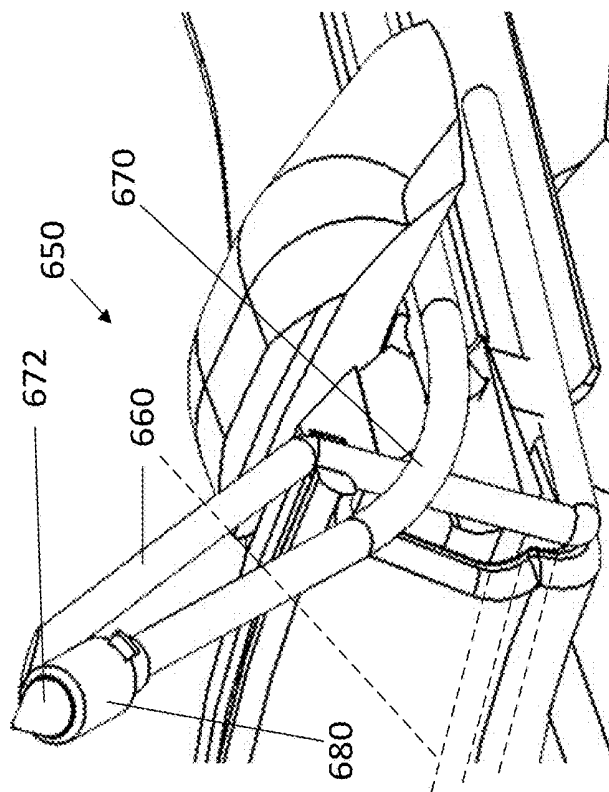

FIG. 29A

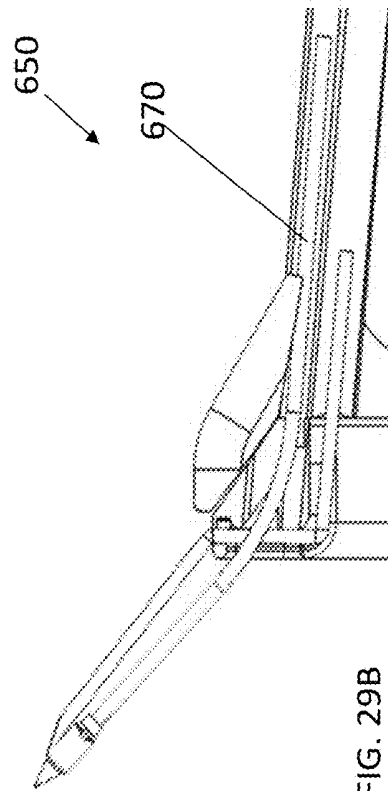
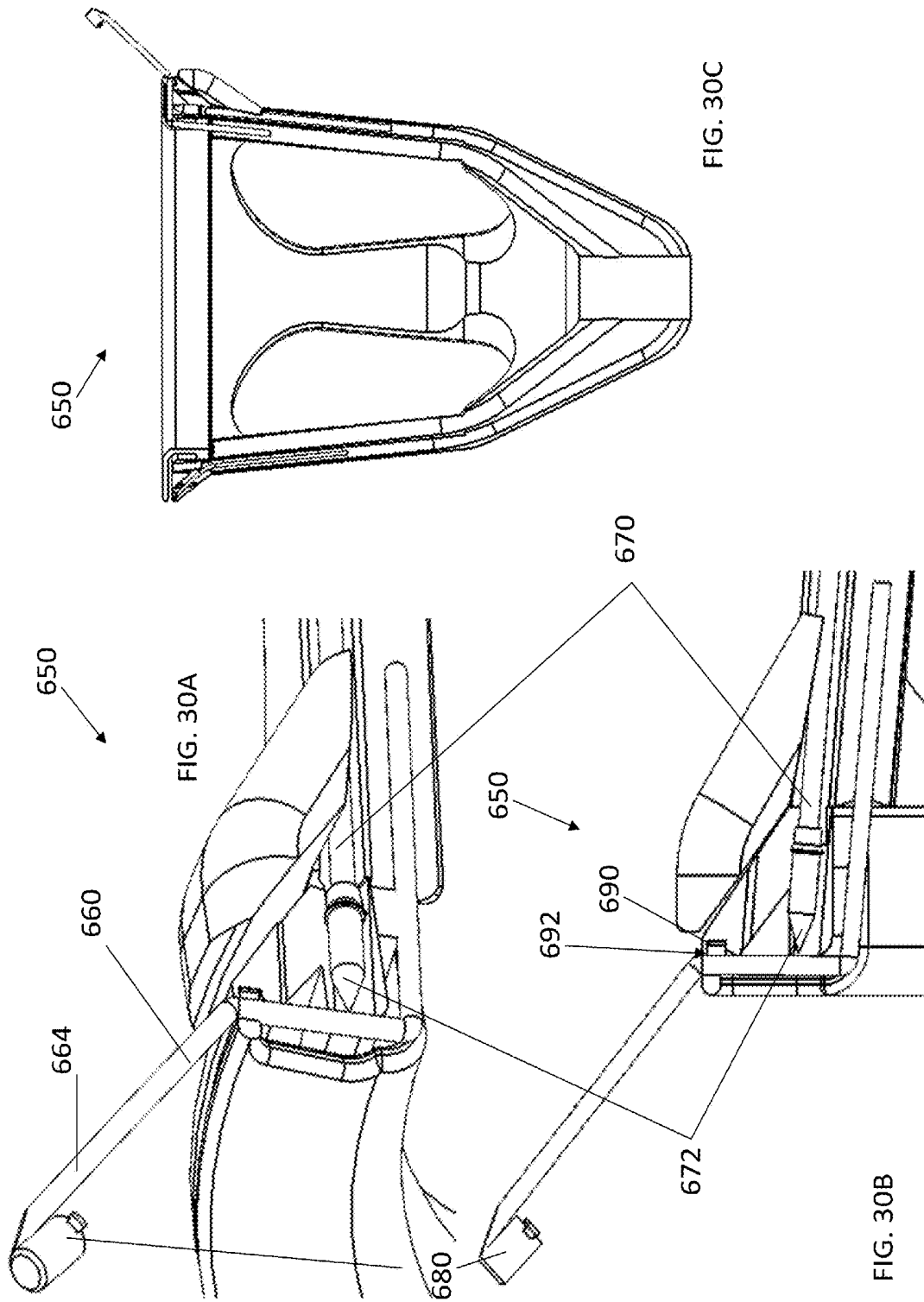

FIG. 29B



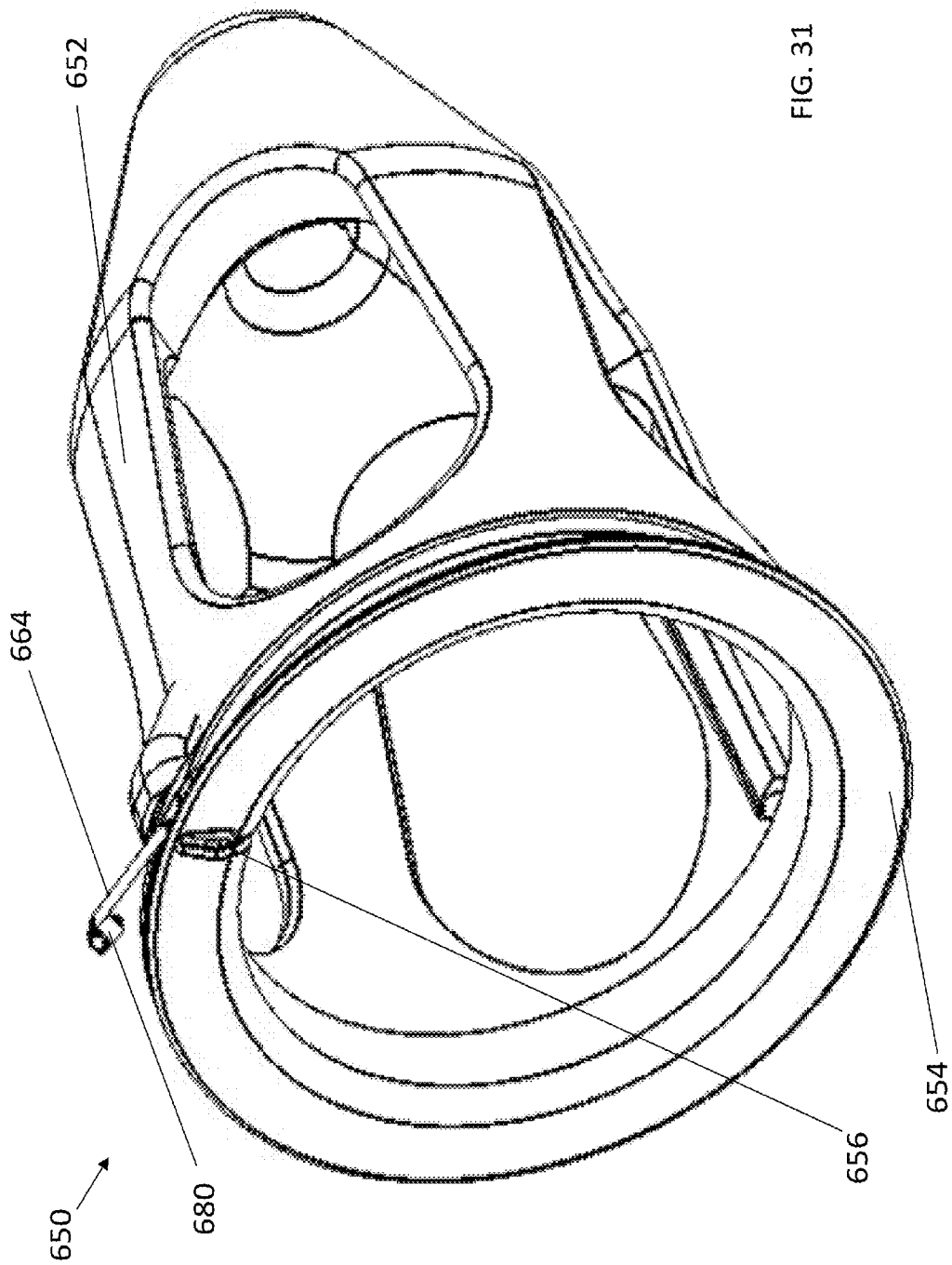

FIG. 31

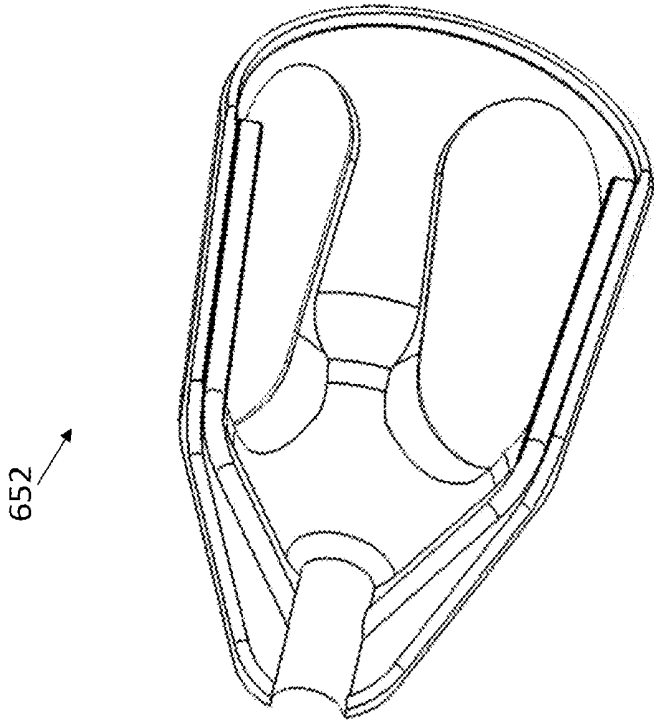

FIG. 32B

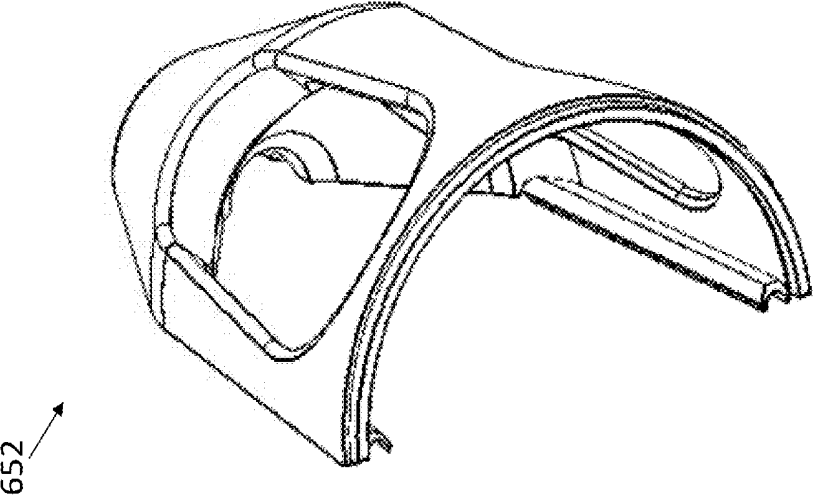

FIG. 32A

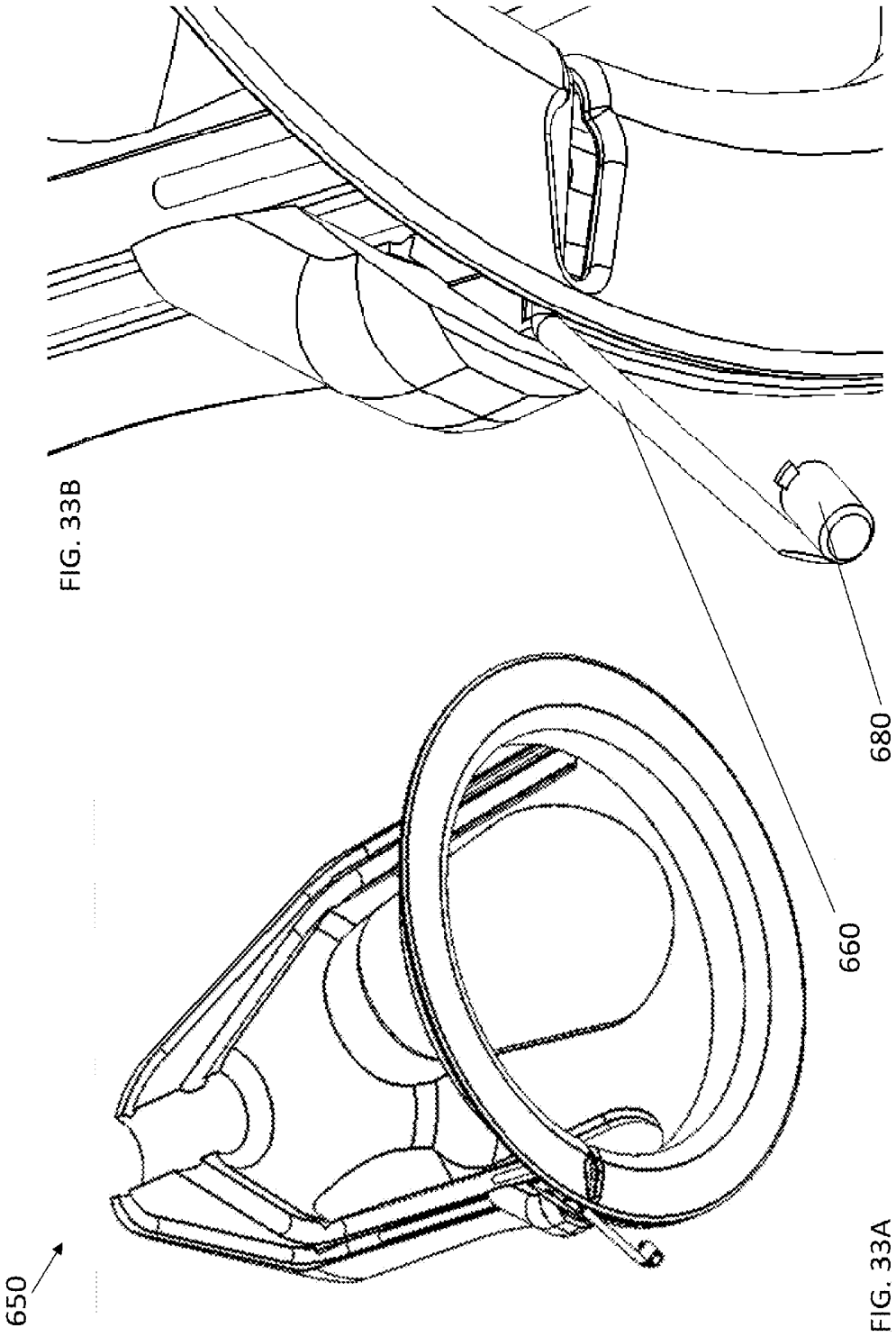

FIG. 33B

FIG. 33A

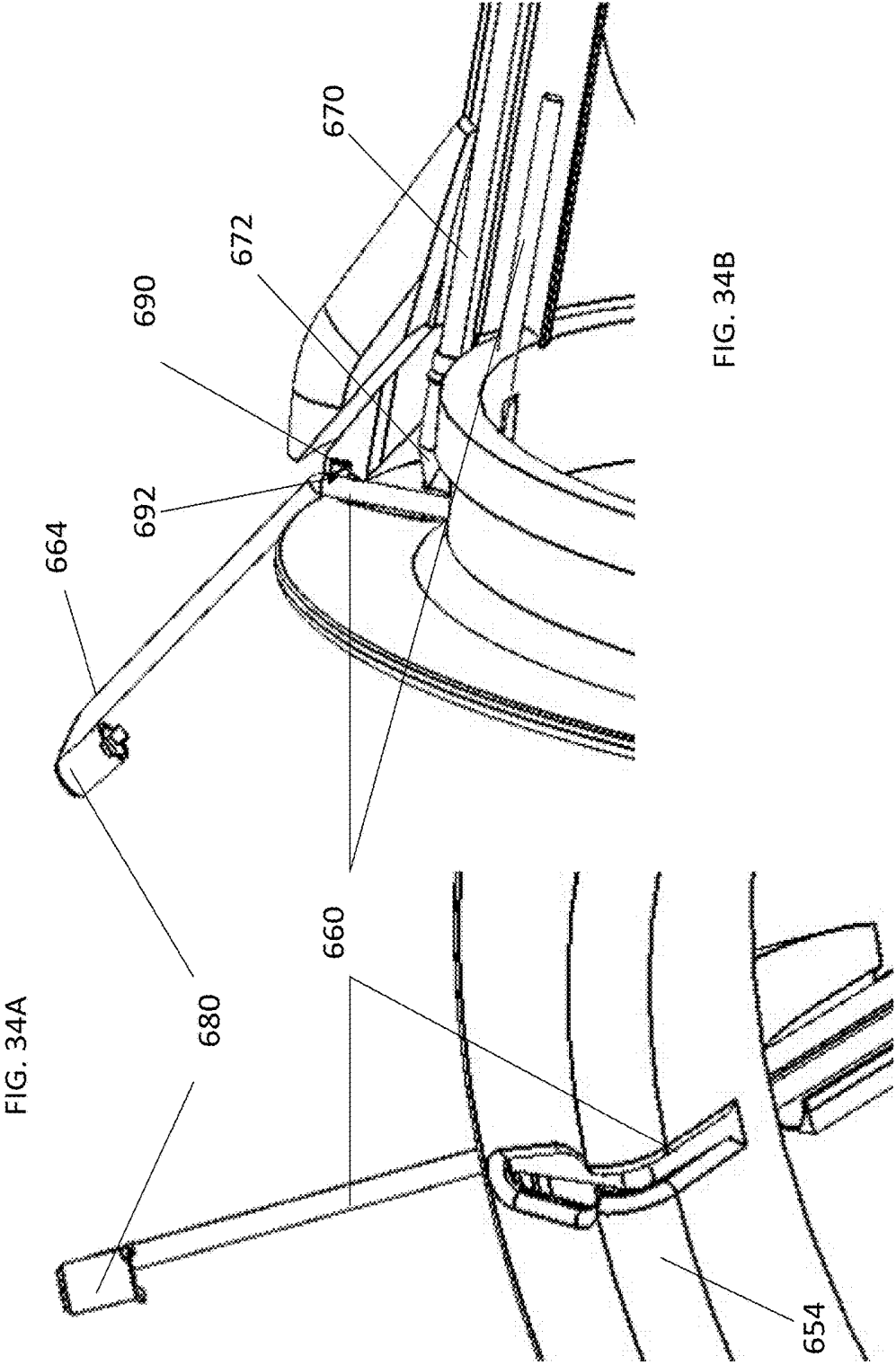

FIG. 34A

FIG. 34B

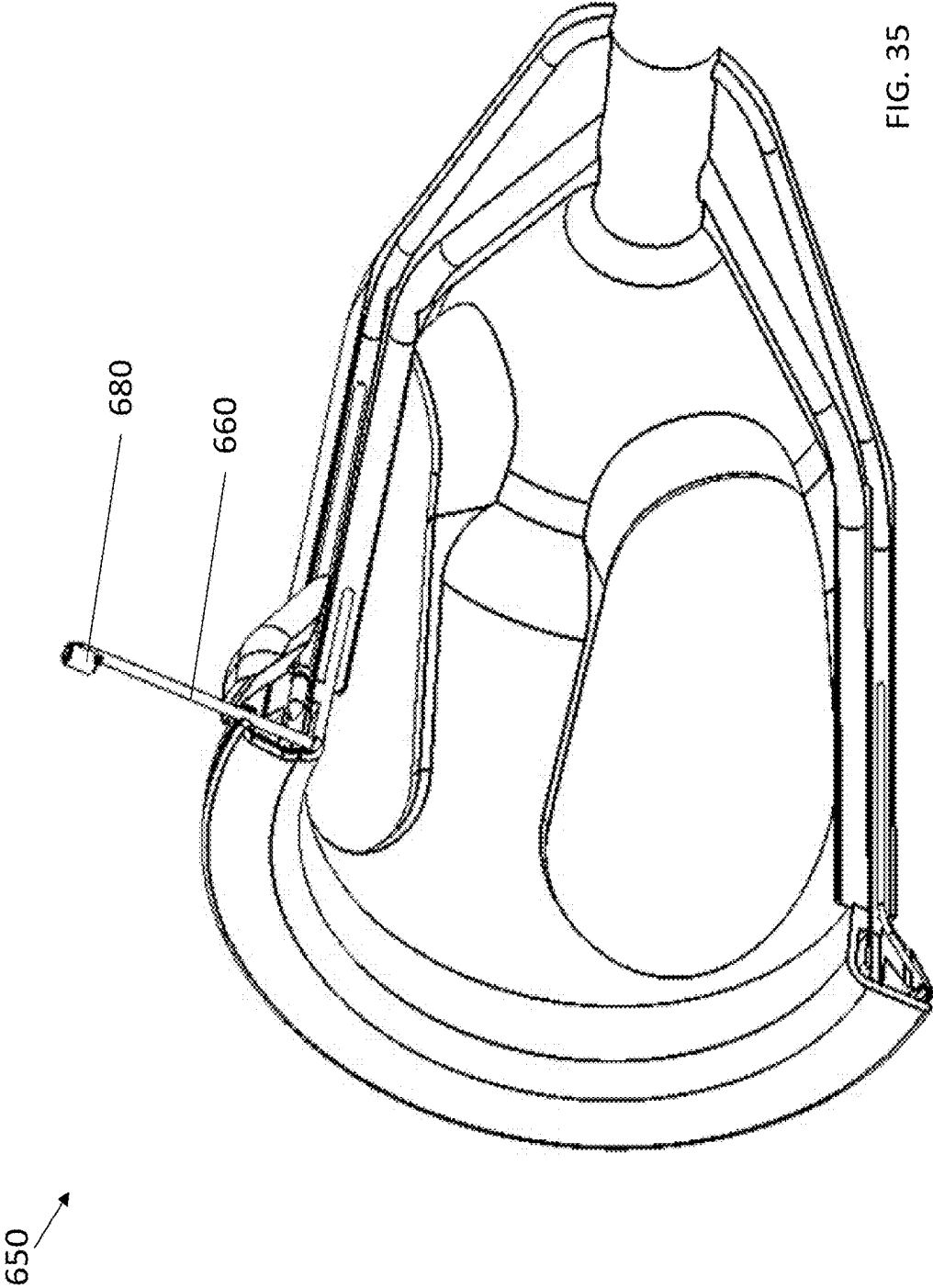

FIG. 35

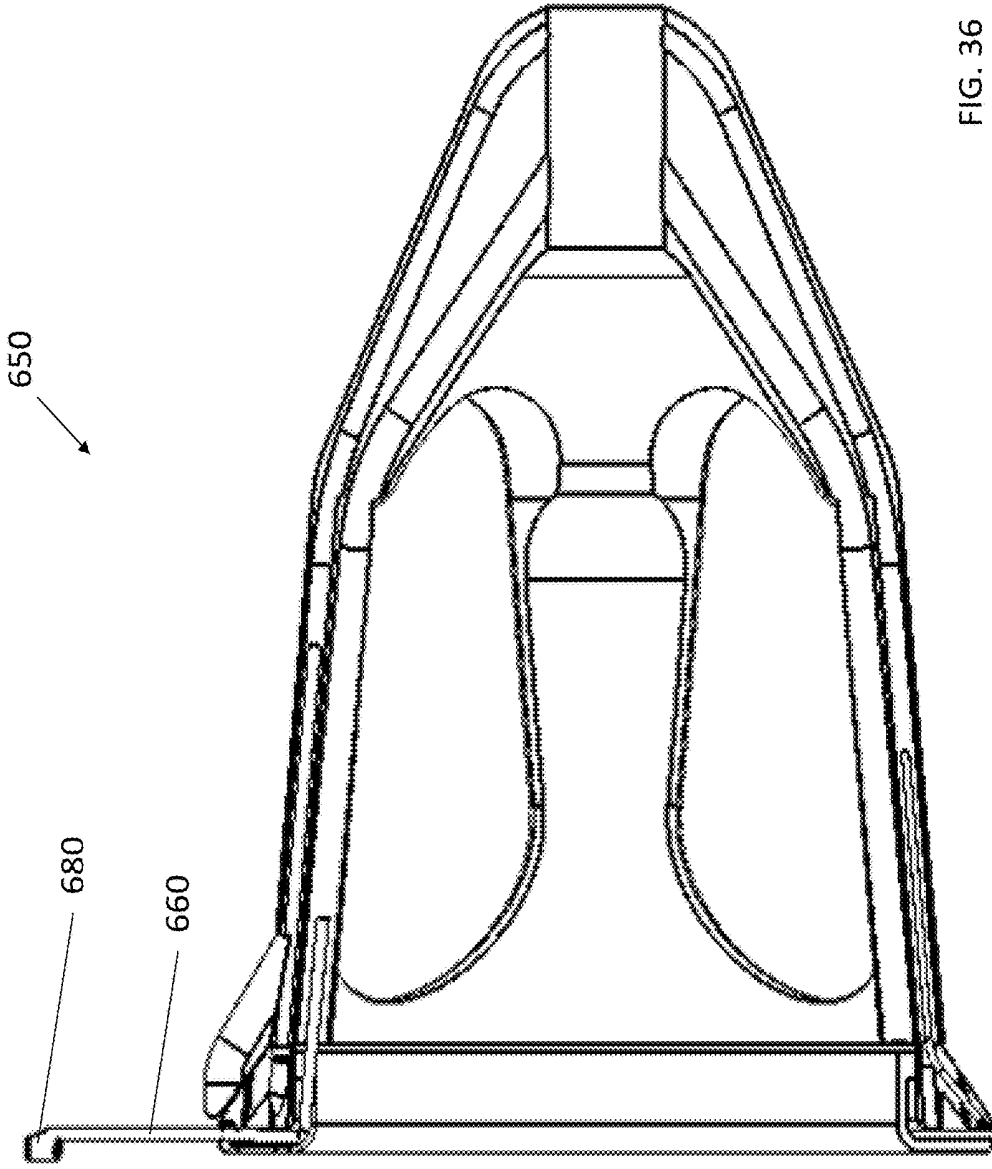

FIG. 36

FIG. 37A

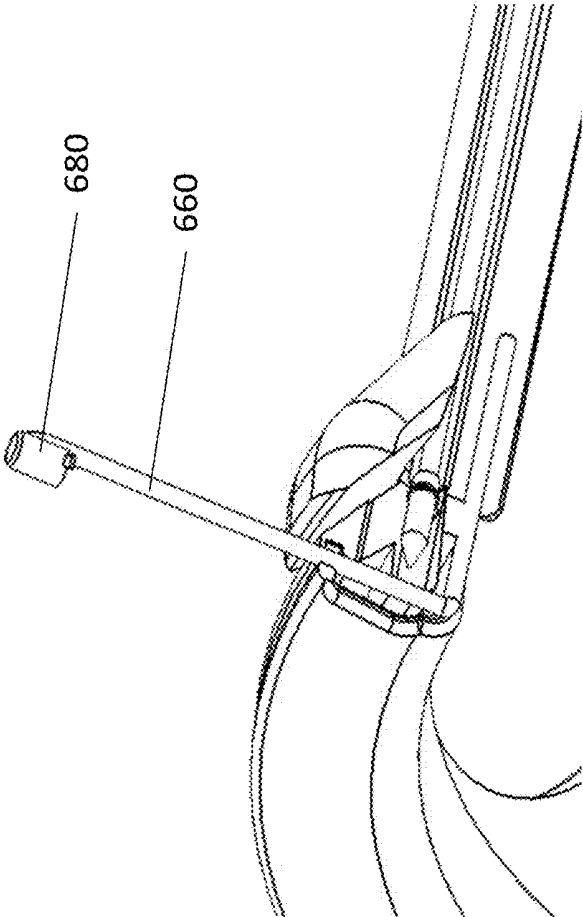
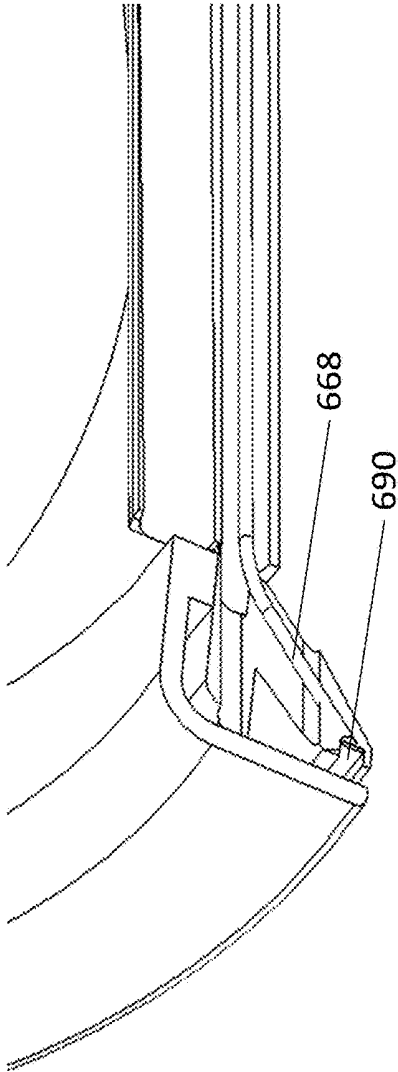
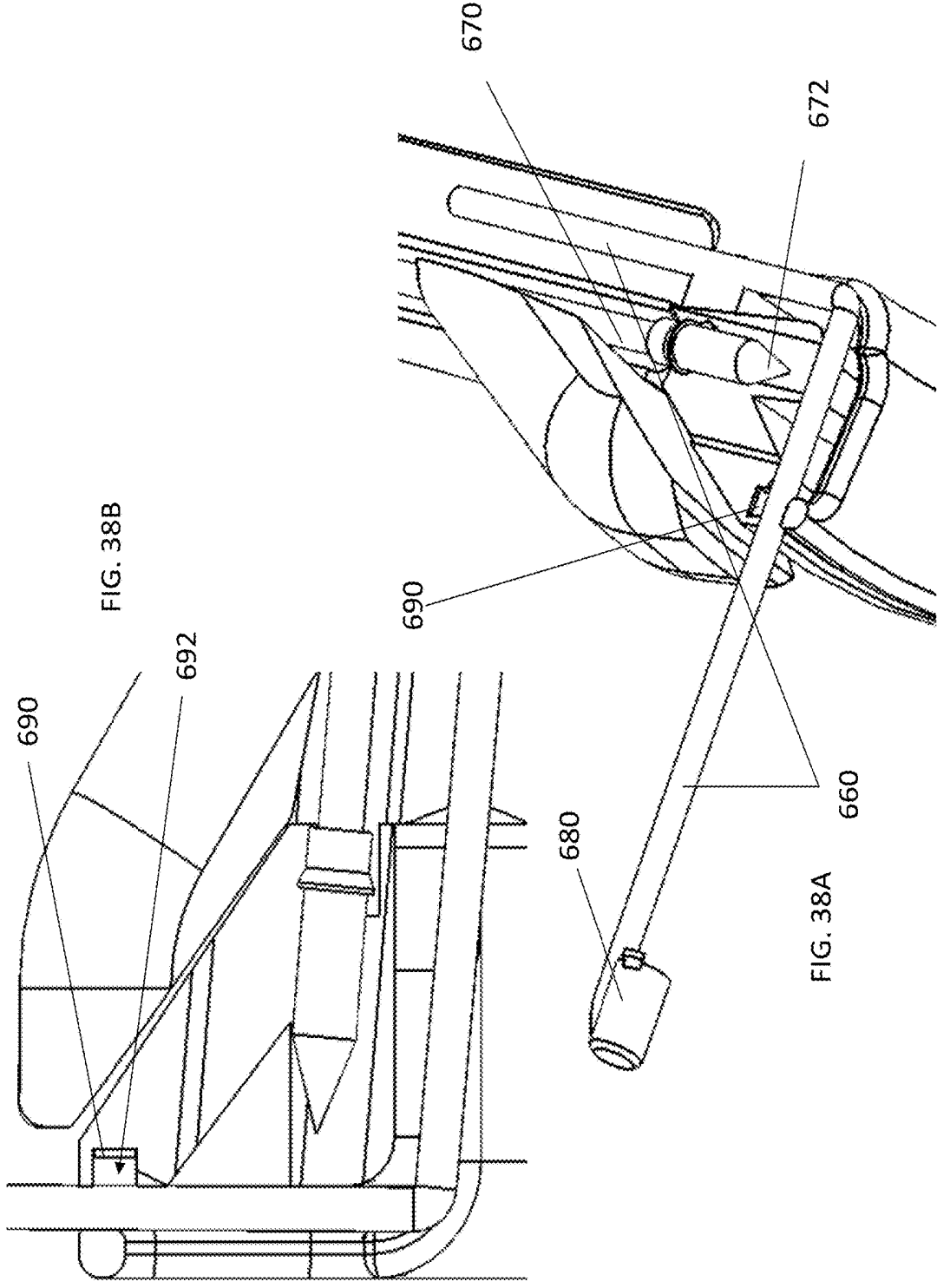

FIG. 37B





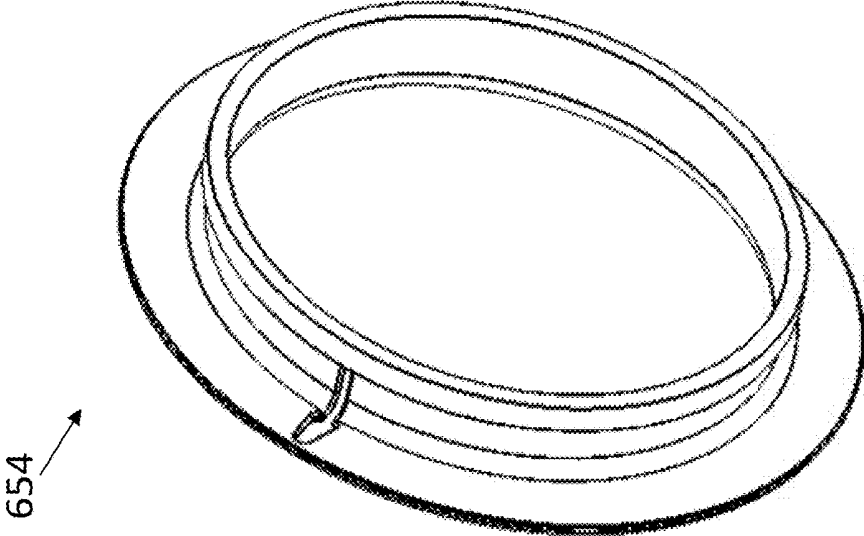

FIG. 39B

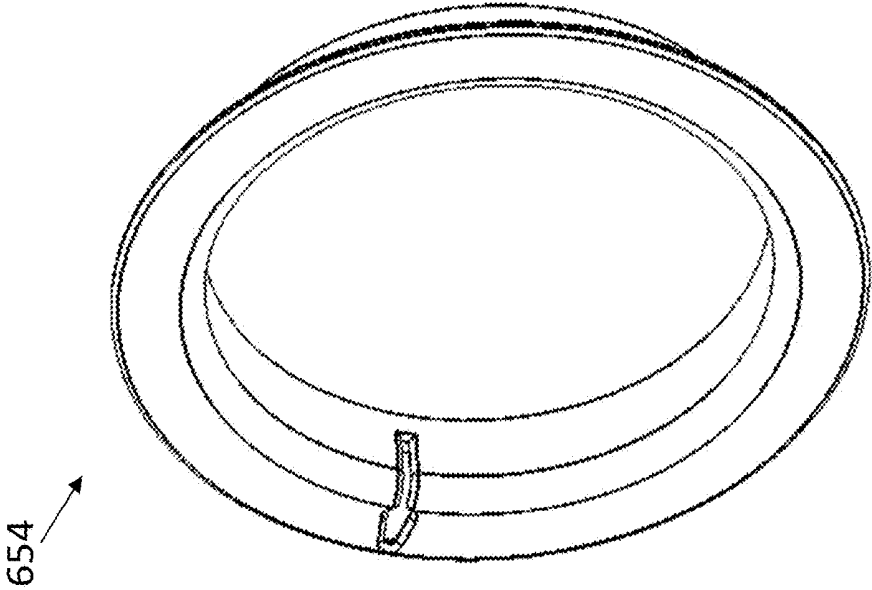

FIG. 39A

## UTERINE MANIPULATOR WITH CUTTING HEAD

### CROSS-REFERENCE TO RELATED APPLICATIONS

[0001] The present patent application is a continuation of and claims the benefit of priority to International Patent Application No. PCT/US2018/47402, filed Aug. 21, 2018, which in turn claims the benefit of priority to U.S. Provisional Patent Application No. 62/548,252, filed Aug. 21, 2017. Each of the foregoing patent applications is hereby incorporated by reference herein for any purpose whatsoever.

### BACKGROUND

[0002] The present disclosure relates generally to uterine manipulators and methods of using a uterine manipulator. Uterine manipulators can be used, for example, as aids in laparoscopic hysterectomies.

### SUMMARY

[0003] Embodiments of the present disclosure can be used to mobilize and position the uterus, to provide better visualization of the vagina and the cervix for facilitating their separation, and to remove the uterus after colpotomy is performed. An embodiment in accordance with the present disclosure can include a handle, a shaft, an inflatable balloon, and a cervical stop. The handle can be located at a proximal end of the shaft and the inflatable balloon can be located near the distal end of the shaft. The inflatable balloon can be maneuvered into the uterus in a deflated condition and then inflated (e.g., via saline or water injected through the shaft) to help stabilize the uterine manipulator during a procedure. The inflatable balloon can be used to remove the uterus after it has been separated from the vagina. Once the uterine manipulator is positioned, the cervical stop can be adjusted to abut the cervix.

[0004] Another embodiment of can include a handle, a shaft, an inflatable balloon, a cervical cup, and an occluder. The handle, the shaft, and the inflatable balloon can have similar functions as described above. The cervical cup can be fitted around the cervix and pressed inward against the vaginal fornix in order to provide an observable or palpable landmark of an incision point, such as that for dissecting the cervix and uterus from the vagina, and to physically separate the incision area from nearby ureters. An incision for detaching the uterus and cervix from the vagina can be executed laparoscopically (e.g., via a hook electrode). The occluder, positioned within the vagina when the uterine manipulator is set, makes can make continuous radial contact with the vaginal wall in order to maintain pneumoperitoneum after the incision between the vagina and the cervix has been made. The occluder can be a silicone cup pushed up the shaft and pressed into the vagina, or a balloon slid onto the shaft and inflated so that it presses against the vaginal wall.

[0005] In some embodiments, a uterine manipulator is provided that includes a shaft including a first end, a second end, and a channel along an axis of the shaft, a handle coupled to the first end of the shaft, and a triangular balloon coupled to the second end of the shaft, the triangular balloon being configured and arranged to match the shape of an inner portion of a uterus upon inflation, wherein the triangular balloon is in fluid communication with a fluid reservoir

containing inflation fluid by way of the channel, the fluid reservoir being coupled to an actuator, and further wherein the triangular balloon is configured to be selectively inflated with fluid upon insertion into a uterus by actuating the actuator to cause the triangular balloon to conform to an inner surface of the uterus.

[0006] If desired, the proximal tip of the triangular balloon can be connected to the shaft, and the distal end of the triangular balloon can include two distal tips located at outward corners of the triangular balloon pointing along a direction that is generally perpendicular to a longitudinal axis of the shaft, wherein, upon inflation, the distal tips of the triangular balloon are sized and shaped to be located near the entrances to a patient's fallopian tubes. The two distal tips of the triangular balloon can each include at least one aperture in fluid communication with a channel that traverses the balloon to a fluid reservoir near the proximal end of the manipulator that includes dye fluid and an actuator, wherein actuating the actuator causes dye fluid to flow out of the balloon and toward the fallopian tubes of a patient when the triangular balloon is deployed. If desired, the inflation fluid can be the dye fluid and further wherein the fluid reservoir for the inflation fluid can be the same reservoir for containing the dye fluid. Alternatively, the inflation fluid and dye fluid can be two separate fluids in two separate fluid flow systems.

[0007] In some implementations, the two distal tips of the triangular balloon can each include at least one aperture in fluid communication with an interior portion of the triangular balloon, and further wherein the inflation fluid can include dye fluid, wherein actuating the actuator causes dye fluid to flow out of the balloon and toward the fallopian tubes of a patient when the triangular balloon is deployed. In some embodiments, the dye fluid can be suitable for use in a chromoperturbation procedure. For example, the fluid can include at least one of methylene blue and indigo carmine.

[0008] In further implementations, the uterine manipulator can further include a light source coupled to the second end of the shaft configured to illuminate an interior volume of the uterus. For example, the light source is positioned internally with respect to the triangular balloon. The light source can include at least one LED, for example. If desired, the light source can include a plurality of LEDs operably coupled to a controller, the controller being configured to mix the colors of the LEDs to achieve a desired light output. In some embodiments, the plurality of LEDs can include LEDs having differing color output attributes. The controller can have a control circuit that is operable to tune the temperature of the light of the plurality of the LEDs to a desired temperature. If desired, the controller can be operable to tune the temperature of the light of the plurality of the LEDs to a desired color.

[0009] In some implementations, a method of diagnosing a medical condition is provided, including providing a uterine manipulator as set forth above, introducing the triangular balloon into the patient's uterus, and illuminating the light source to illuminate the patient's uterus. The method can further include viewing an inner surface of the uterus using an optic to examine the endometrial lining of the uterus. If desired, the method can include inspecting the patient's uterus externally to search for fibroids, wherein the light source is of sufficient intensity to illuminate the uterus internally.

[0010] If desired, the uterine manipulator can further include a channel coupled to the second end of the shaft and a corner of the triangular balloon, and positioned internal to the triangular balloon, the channel configured and arranged to inject the dye into an opening of a fallopian tube. The shaft can include a groove, and the uterine manipulator can further include a cup. The cup can include a projection that interfaces with the groove of the shaft and is configured to be positioned at a juncture between a cervix and the vagina. If desired, the uterine manipulator can further include a pneumooccluder coupled to the shaft, a first end of a filling tube coupled to a fluid inlet, and a second end of the filling end coupled to the pneumooccluder.

[0011] The disclosure further provides embodiments of a uterine manipulator. The uterine manipulator typically includes a shaft including a proximal end, a distal end, and a channel along a longitudinal axis of the shaft, a handle coupled to the proximal end of the shaft, and a cutting head attached to the distal end of the shaft adapted to cut a tissue segment to separate a vagina from a cervix and uterus. The cutting head typically includes a cup coupled to the distal end of the shaft and configured to be positioned at a juncture between the cervix and a vagina, and a cutting wire coupled to the cup via an aperture in the cup such that a portion of the cutting wire extends away from an exterior surface of the cup. The cutting wire is typically configured to follow a substantially circular path about the longitudinal axis of the shaft when cutting through tissue to separate the cervix from the vagina.

[0012] If desired, a system can be provided including the uterine manipulators described herein, and a power source coupled to the cutting wire to apply electrical current to a cutting wire portion of the uterine manipulator. The uterine manipulator and power source can be configured and arranged to provide monopolar current or bipolar current to a patient. A cup at a distal end of the uterine manipulator can be provided that includes a metal ring coupled thereto. The metal ring can be attached to a return path conductor that leads toward a proximal end of the uterine manipulator.

[0013] If desired, the cutting wire can be configured and arranged to traverse a circumference of the distal portion of the cup along a groove defined between a distal end cap of the cup and a proximal frame portion of the cup. The uterine manipulator can further include a push wire slidably disposed along the uterine manipulator, wherein a distal end portion of the push wire can be configured and arranged to carry a distal portion of the cutting wire outwardly from a distal end portion of the manipulator. The push wire can be configured to traverse an opening defined through an end cap of the distal end portion of the uterine manipulator. The cutting wire can be loaded into a distal end portion of the manipulator. Distal advancement of the push wire can carry the cutting wire distally and radially outward with respect to a distal end of the uterine manipulator.

[0014] The disclosure further provides methods of separating a uterus from a vagina of a patient. The methods typically include providing a uterine manipulator as described herein that include a cutting head, inserting a distal end portion of the uterine manipulator through a cervix of the patient, and deploying the cutting wire through the tissue of the vagina and/or cervix outwardly into an abdominal cavity of the patient.

[0015] If desired, a method can be provided that further includes visualizing the cutting wire in the abdominal cavity

through a laparoscopic procedure including insufflating the abdominal cavity of the patient, and visually locating a portion of the cutting wire extending into the abdominal cavity. The method can further include grasping the cutting wire using a second surgical instrument from within the abdominal cavity, and pulling the wire circumferentially around the cervix to sever the uterus and/or cervix from the vagina. In some implementations, the cutting can be accomplished without application of electrical current to the uterine manipulator. In other embodiments, the cutting can be accomplished with application of electrical current to the uterine manipulator.

[0016] Some previous approaches may present drawbacks. Some previous approaches to intrauterine balloons do not conform to the uterine cavity and therefore do not offer optimal mobilization of the uterus. Further, while some previous approaches offer chromopertubation, the dye is injected from the tip of the manipulator and may be inadvertently injected into the uterine muscle, which may affect fertility. Also, entry into the uterine cavity during a myomectomy is not easily detected with some previous approaches. In addition, some previous approaches may only serve to provide guidance for detaching the uterus and the cervix from the vagina via laparoscopic tools.

[0017] At least one embodiment in accordance with the present disclosure overcomes these drawbacks.

#### BRIEF DESCRIPTION OF THE DRAWINGS

[0018] FIG. 1 is a perspective view of a uterine manipulator according to the present disclosure.

[0019] FIG. 2 is another perspective view of the uterine manipulator of FIG. 1.

[0020] FIG. 3 is an exploded perspective view of the uterine manipulator of FIG. 1.

[0021] FIGS. 4A and 4B are partial side views of a handle and a tip assembly, respectively, of the uterine manipulator of FIG. 1.

[0022] FIGS. 5A and 5B are additional partial side views of the handle and the tip assembly, respectively, of the uterine manipulator of FIG. 1.

[0023] FIGS. 6A-6C are side views of the uterine manipulator of FIG. 1 in different pivoting positions.

[0024] FIGS. 7A-7D are side and front views of the handle assembly of the uterine manipulator of FIG. 1 in different pivoting positions.

[0025] FIGS. 8A and 8B are side views of the uterine manipulator of FIG. 1 in a retracted position and an expanded position, respectively.

[0026] FIGS. 9A and 9B are perspective views of a cutting assembly and a backstop, respectively, of the uterine manipulator of FIG. 1.

[0027] FIGS. 10A and 10B are side views of the cutting assembly and an electrical connector assembly, respectively, of the uterine manipulator of FIG. 1.

[0028] FIG. 11 is a perspective view of a pneumooccluder of the uterine manipulator of FIG. 1.

[0029] FIGS. 12A-12D are cross-sectional views of a pelvic cavity and the uterine manipulator of FIG. 1.

[0030] FIG. 13 is a perspective view of a manipulator, cup, and cutting assembly in accordance with the present disclosure.

[0031] FIG. 14 is a series of views showing use of the cutting assembly of FIG. 13 in accordance with the present disclosure.

[0032] FIGS. 15A-15B are side views of a uterine manipulator in accordance with the present disclosure.

[0033] FIG. 16 illustrates a uterine manipulator in accordance with the present disclosure.

[0034] FIG. 17 illustrates the distal portion of the uterine manipulator and the balloon in accordance with the present disclosure.

[0035] FIG. 18 illustrates the distal portion of a uterine manipulator and the balloon 418 in accordance with the present disclosure inserted into a patient's uterus.

[0036] FIG. 19A illustrates a partial perspective view of the uterine manipulator of FIG. 16.

[0037] FIG. 19B illustrates a cross-sectional view of the stopper and the key of FIG. 16.

[0038] FIG. 20 illustrates a cross-sectional view of the handle assembly of FIG. 16.

[0039] FIG. 21A illustrates a perspective view of the cup of FIG. 16.

[0040] FIG. 21B illustrates another perspective view of the cup of FIG. 16.

[0041] FIG. 21C illustrates a cross-sectional view of the cup of FIG. 16.

[0042] FIG. 22 illustrates a distal portion of the uterine manipulator of FIG. 16.

[0043] FIG. 23 illustrates a partial side view of a cutting assembly in accordance with the present disclosure.

[0044] FIG. 24 illustrates a perspective view of a cap of the cutting assembly of FIG. 1.

[0045] FIG. 25 illustrates a perspective view of a cutting assembly in accordance with the present disclosure.

[0046] FIG. 26A is a side view of a further representative embodiment of a uterine manipulator in accordance with the present disclosure, and FIG. 26B is an enlarged view of the distal end as presented in FIG. 26A.

[0047] FIG. 27A is a side sectional, or cut-away view of the embodiment of FIGS. 26A-26B, and FIG. 27B is an enlarged cut-away view of the distal end as presented in FIG. 27A.

[0048] FIG. 28 is a close up cross sectional view of the distal end portion of the uterine manipulator presented in FIG. 26A.

[0049] FIGS. 29A, 29B and 29C are a partial section isometric end view, a partial side section view and a full section view of the distal end portion of the uterine manipulator presented in FIG. 26A with the cutting wire partially deployed.

[0050] FIGS. 30A, 30B and 30C are a partial section isometric end view, a partial side section view and a full section view of the distal end portion of the uterine manipulator presented in FIG. 26A with the cutting wire partially deployed and the push wire retracted into the device after advancing the hot lead through tissue.

[0051] FIG. 31 is an isometric end view of the distal end portion of the uterine manipulator presented in FIG. 26A with the hot lead partially deployed as in FIGS. 30A, 30B and 30C.

[0052] FIGS. 32A-32B are outer and inner isometric views of a segment of the distal end portion of the uterine manipulator presented in FIG. 26A with the hot lead partially deployed as in FIGS. 30A, 30B and 30C.

[0053] FIGS. 33A-33B are outer and inner isometric views of the distal end portion of the uterine manipulator

presented in FIG. 26A with the portion illustrated in FIGS. 32A-32B removed with the hot lead partially deployed as in FIGS. 30A, 30B and 30C.

[0054] FIGS. 34A-34B are upwardly directed isometric and side cutaway isometric close up views of segments of the distal end portion of the uterine manipulator presented in FIG. 26A with the portion illustrated in FIGS. 32A-32B removed with the hot lead partially deployed as in FIGS. 30A, 30B and 30C.

[0055] FIG. 35 is an isometric section view of the distal end portion of the uterine manipulator presented in FIG. 26A with the hot lead fully deployed and positioned to cut through tissue to separate a cervix and uterus from a vaginal wall.

[0056] FIG. 36 is a side section view of the distal end portion of the uterine manipulator presented in FIG. 26A with the hot lead fully deployed and positioned to cut through tissue to separate a cervix and uterus from a vaginal wall.

[0057] FIG. 37A is an isometric close up section view of the distal end portion of the uterine manipulator presented in FIG. 26A with the hot lead fully deployed and positioned to cut through tissue to separate a cervix and uterus from a vaginal wall.

[0058] FIG. 37B is an isometric close up section view of the distal end portion of the uterine manipulator presented in FIG. 26A showing a portion opposite the hot lead, illustrating a portion of a conductive ring connected to a further electrical conductor for providing a return path for applied power.

[0059] FIG. 38A is a further isometric close up section view of the distal end portion of the uterine manipulator presented in FIG. 26A with the hot lead fully deployed and positioned to cut through tissue to separate a cervix and uterus from a vaginal wall.

[0060] FIG. 38B is a side close up sectional view of a distal end portion of the uterine manipulator presented in FIG. 26A with the hot lead fully deployed and positioned to cut through tissue to separate a cervix and uterus from a vaginal wall, specifically illustrating a portion of a ring-shaped, or toroidal gap defined between the hot lead and a conductive ring attached to a return conductor.

[0061] FIGS. 39A-39B illustrate a ring shaped end cap of the uterine manipulator presented in FIG. 26A illustrating an opening therein for accommodating passage of a push wire in accordance with the present disclosure.

#### DETAILED DESCRIPTION

[0062] FIGS. 1 and 2 illustrate a uterine manipulator according to the present disclosure. At least one embodiment can be used in laparoscopic hysterectomies, robotic hysterectomies, laparoscopic myomectomies, and/or other pelvic procedures. The uterine manipulator 10 can include a handle 12, a shaft 14, a tip assembly 16, a cutting assembly 18, a pneumooccluder 20, and an electrical connector assembly 22. During use, the uterine manipulator 10 can be inserted into a patient's vagina no, as shown in FIG. 12A, and then guided past the cervix 112 and into the uterus 114, as shown in FIG. 12B, using the handle 12. As shown in FIGS. 12B and 12C, when the uterine manipulator 10 is inserted, the tip assembly 16 can be positioned in the uterus 114, the cutting assembly 18 can be positioned adjacent to the vaginal fornix 118 and can press against the cervix 112, and the pneumooccluder 20 can be positioned inside the vagina no.

[0063] As shown in FIG. 3, the tip assembly 16 can include an expansion tip 24, a tip shaft 26, expansion elements 28, an abutment 30, and a tip housing 32, and the handle 12 can include a handle housing 34, an expansion actuator 36, a cap 38, a hinge 40, hinge pins 42, and a pivoting element 44. The shaft 14 can be coupled to the tip assembly 16 via the tip housing 32, and can be coupled to the handle 12 via the pivoting element 44. The tip assembly 16 can be coupled to the handle 12 via connectors 46. As shown in FIGS. 4A and 4B, the connectors 46 can be routed from inside the handle housing 34, through the shaft 14, and coupled to the tip housing 32. As shown in FIGS. 3, 5A and 5B, expansion connectors can be coupled to the expansion actuator 36, routed from inside the handle housing 34 through the shaft 14 and coupled to the expansion tip 24 for actuating the tip assembly 16, as further described below. In at least one embodiment, some or all of the components of the uterine manipulator 10 can be disposable. Some or all of the components can be removable from one another, for example, so that disposable components can be uncoupled from permanent components and replaced with new disposable components.

[0064] As shown in FIGS. 6A-6C, the tip assembly 16, the shaft 14, and the handle 12 can be pivotable relative to each other at two separate pivot points 50, 52. The first pivot point 50 and the second pivot point 52 can facilitate insertion of the uterine manipulator 10 into the uterus 114 and can also facilitate repositioning of the uterus 114 during a hysterectomy. The first pivot point 50 can be located at the connection between the tip housing 32 and the shaft 14. For example, as shown in FIGS. 4B and 5B, the end 54 of the tip housing 32 can be positioned between end components 56 of the shaft 14 so that through holes 58 in each component 54, 56 are aligned, and a pin 60 can be routed through the through holes 58 to permit a pivotable connection. The second pivot point 52 can be located at the connection between the shaft 14 and the handle 12. For example, as shown in FIGS. 4A, 5A, and 7A-7D, the shaft 14 can be fixed to the pivoting element 44 (e.g., via a pin 60 and through hole 58 connection) and the pivoting element 44 can be pivotable about the hinge 40 within the handle housing 34. The hinge pins 42 can extend through the handle housing 34, the hinge 40, and a track 62 of the pivoting element 44, as best shown in FIG. 7D. The track 62 can be ribbed so that the pivoting element 44 cannot freely slide within it. Rather, the pivoting element 44 can be substantially fixed at specific points along the ribbed track 62 and only adjusted by applying an amount of force. This can prevent unwanted movement of the second pivot point 52 unless a deliberate force is applied.

[0065] In at least one embodiment, an additional mechanism (for example, in the handle 12), can be used to control both pivot points 50, 52. For example, if the additional mechanism is actuated in a first direction, both pivot points 50, 52 can be locked in place. If the additional mechanism is actuated in a second direction, both pivot points 50, 52 can be unlocked and maneuverable. The shaft 14 can be constructed of a non-rigid, flexible material to facilitate insertion of the uterine manipulator 10 into the uterus 114.

[0066] The tip assembly 16 can act as an umbrella-like expansion component capable of being adjusted between a retracted position and an expanded position. As a result, the tip assembly 16 can replace conventional intra-uterine balloon elements. The tip assembly 16 can be situated into the

retracted position, as shown in FIGS. 8A and 12B, to facilitate insertion into the uterus 114 (e.g., until the abutment 30 reaches the cervix 112). Once inserted into the uterus 114, the tip assembly 16 can be deployed into the expanded position, as shown in FIGS. 8B and 12C, to facilitate a secure connection between the uterine manipulator 10 and the uterus 114 and cervix 112.

[0067] The expansion elements 28 can be spring-like elements capable of being in compression (e.g., shortened in length) and in tension (e.g., lengthened). Pulling the expansion actuator 36 away from the handle housing 34 can cause the expansion elements 28 to compress and expand outward circumferentially, situating the tip assembly 16 into the expanded position. Pushing the expansion actuator 36 back into the handle housing 34 causes the expansion elements 28 to retract back into tension and lengthen, situating the tip assembly 16 into the retracted position. Alternatively, the expansion actuator 36 can be twisted or rotated, rather than pulled and pushed from the handle housing 34, to adjust the expansion elements 28.

[0068] As shown in FIGS. 4B and 5B, the expansion tip 24 can slide into the tip shaft 26 until an end stop 64 of the expansion tip 24 reaches the end 66 of the tip shaft 26. The expansion elements 28 can fit over the tip shaft 26 until a first end 68 of the expansion elements 28 reaches the end 66 of the tip shaft 26. Both the expansion tip 24 and the tip shaft 26 can be slid into the tip housing 32, while the second end 70 of the expansion elements 28 can rest against an outer edge 72 of the tip housing 32. Pulling the expansion actuator 36 outward from the handle housing 34 causes the expansion connectors 48 to pull the expansion tip 24, and the tip shaft 26, further into the tip housing 32. Because the expansion elements 28 rest against the edge 72 of the tip housing 32, they are compressed (i.e., shortened in length) when the expansion tip 24 and the tip shaft 26 are forced into the tip housing 32. Shortening of the expansion elements 28 causes them to expand in their circumferential direction, therefore situating the tip assembly 16 into the expanded position. In the reverse, pressing the expansion actuator 36 back into the housing releases the pulling tension of the expansion connectors 48 on the expansion tip 24. The expansion elements 28 can be in a resting state when in tension and thus, without the pulling tension by the expansion connectors 48, the expansion elements 28 will revert back to their resting, retracted state, thereby pulling the expansion tip 24 and the tip shaft 26 back out from the tip housing 32 and situating the tip assembly 16 into the retracted position.

[0069] Referring back to FIGS. 1 and 2, the cutting assembly 18 can be slid over the shaft 14 and can be rotatable about the shaft 14. The cutting assembly 18 can include a backstop 74, a tube 76, a cutting handle 78, fasteners 80, and a spring 81. The backstop 74 can be positioned at a first end of the tube 76 and the cutting handle 78 can be positioned at a second, opposite end of the tube 76. The tube 76 can be slid over the shaft 14 and the cutting handle 78 can help maneuver the cutting assembly 18 along and/or around the shaft 14. The fasteners 80 can help fix the cutting assembly 18 in place along the shaft 14. The backstop 74 can receive the cervix 112 and come in contact with the vaginal fornix 118 when the uterine manipulator 10 is in position. The backstop can then be maneuvered in a circular manner to cut around the cervix 112 for detaching the cervix 112 and the uterus 114 from the vagina 110, as shown in FIG. 12D. As shown in FIGS. 10A and 10B, the backstop 74 can

include a round cup portion **82** and a cutter **84** extending outward from the cup portion **82**. During use, the cutting assembly **18** can be pressed up against the abutment **30** of the tip assembly **16** so that the cup portion **82** extends past the abutment **30** and engages the fornix, stretching and forcing the fornix upward and away from the ureters. The cutter **84** can pierce through the tissue of the fornix, transecting the uterus **114** and the cervix **112** from the top of the vagina **110**.

[0070] The cutting assembly **18** can be rotated about the shaft **14** (e.g., by the cutting handle **78**), allowing the cutter **84** to travel in a circle at the junction of the cervix **112** and the vagina **110** and permitting complete transection of the uterus **114** and the cervix **112** from the vagina **110**. The spring **81** can help distribute rotational forces evenly across the tube **76** when the cutting assembly **18** is rotated, for example, to prevent the tube **76** from breaking due to excess torque concentrated along one portion of the tube **76**.

[0071] The electrical connector assembly **22** can advance the cutter **84** outward from the cup portion **82** to achieve the detachment procedure described above, and can retract the cutter **84** inward to facilitate insertion of the uterine manipulator **10** into the uterus **114** without piercing the vaginal walls **120** prior to proper positioning of the uterine manipulator **10**. The electrical connector assembly **22** can provide an electrical connection between the cutter **84** and an electrosurgical unit (not shown) in order to provide hemostasis during the detachment procedure. The electrical connector assembly **22** can include a handle **94**, a cap **96**, a button **98**, tubing **100**, **102**, and electrical connectors **104**, **106**. On one end of the electrical connector assembly **22** (i.e., adjacent to the cap **96**), the tubing **100** and the electrical connectors **104** can be routed to the electrosurgical unit. On the other end of the electrical connector assembly **22**, the tubing **102** and the electrical connectors **106** can be routed to the cutter **84**. The electrical connectors **104**, **106** can be electrically connected through the button **98** so that current can be routed from the electrosurgical unit to the cutter **84**. The electrical connectors **106** can be coupled to the cutter **84** and the button **98** so that pressing the button **98** forward and backward causes the cutter **84** to extend and retract, respectively.

[0072] Referring to FIG. 11, the pneumooccluder **20** can include a balloon **86**, a filling tube **88**, and a bearing **90**. The bearing **90** can be in contact with the tube **76** of the cutting assembly **18**, and the balloon **86** can be positioned around the bearing **90**. As shown in FIG. 11, the bearing **90** can include an outer groove **92** to allow passage of the electrical connector assembly tubing. During use, the pneumooccluder **20** can be positioned within the vagina **110** when the uterine manipulator **10** is set within the uterus **114**. Once in position, the balloon **86** can be inflated via the filling tube **88** (e.g., with air, water, saline, or another fluid) in order to seal the distal vaginal cavity **122** from the proximal vaginal cavity **124**. This can help maintain pneumoperitoneum once the incision has been made between the vagina **110** and the cervix **112** (i.e., causing the proximal vaginal cavity **124** to be in fluid communication with the abdominal cavity). As a result of the bearing **90**, the shaft **14** and/or the cutting assembly tube **76** can be rotated without requiring rotation of the balloon **86**. Because the balloon **86** can be set in place and does not need to be rotated when the shaft **14** or the cutting assembly **18** is rotated, the risk of losing pneumoperitoneum is greatly reduced.

[0073] Thus, the uterine manipulator **10** can be inserted into a patient's vagina **110** while in the retracted position, as shown in FIG. 12A. The uterine manipulator **10** can then be further guided through the vagina **110**, past the cervix **112**, and into the uterus **114**, while still in the retracted position, as shown in FIG. 12B. Once set in the uterus **114**, the uterine manipulator **10** can be situated into the expanded position, as shown in FIG. 12C, in order to facilitate a secure connection between the uterine manipulator **10** and the uterus **114**. Once the uterine manipulator **10** is set within the uterus **114**, the pneumooccluder **20** can contact the vaginal wall **120** in order to seal the uterus **114** from the outside environment and the backstop **74** can abut the vaginal fornix **118**, causing it to stretch upward. Once the uterine manipulator **10** is situated into the expanded position, the cutter **84** can be extended and the cutting handle **78** can be rotated in order to transect the uterus **114** and the cervix **112** from the top of the vagina **110**. The uterine manipulator **10** of the present invention and its above-described procedures can thus eliminate the need for a colpotomy incision via laparoscopic tools, as in conventional laparoscopic and robotic hysterectomies.

[0074] At least one embodiment can include any combination of one or more of the above-described components and/or other conventional uterine manipulator components. The above-described components, such as the cutting assembly **18**, the tip assembly **16**, and the pneumooccluder **20** can function independently from one another and therefore can be individually incorporated into a uterine manipulator with or without the other components. For example, it may be preferable to include the pneumooccluder **20** as described above with some previous approaches to best execute a specific pelvic procedure.

[0075] Referring to FIG. 13, a cutting assembly **200** is illustrated. The cutting assembly **200** can be used with the functional uterine manipulator **10** of the preceding figures or can be used with other systems. The cutting assembly **200** includes a cup portion **202** and an expansion tip **204** extending therethrough. As illustrated in FIG. 13, the expansion tip **204** can be a balloon-type design or other configurations, such as described above. Associated with the cup portion **202** is a cutter or cutter wire **206**. The cup portion **202** is designed to engage the cervix **112**, such as previously described. The cutter **206** is formed as a narrow wire, with a looped tip, embedded between two grooves **208**, **210** on the cup portion **202** (that is, around the circumference of the cup portion **202**).

[0076] FIGS. 15A-15B illustrate another uterine manipulator **300**. The uterine manipulator **300** can include a handle **312**, a shaft **314**, a tip assembly **316**, and a cutting assembly **318**. Unless otherwise stated, the elements of the uterine manipulator **300** can be similar in function and structure to those of the above-described uterine manipulator **100** of the previous figures. The uterine manipulator **300** can incorporate any of the above-described elements of the previous figures. For example, the tip assembly **316** can include an expansion tip **324**, a tip shaft **326**, umbrella-like expansion elements **328**, an abutment **330**, and a tip housing **332**. The handle **312** can include a handle housing **334** and an expansion actuator **336**. Twisting or rotating the expansion actuator **336** in a first direction causes the expansion elements **328** to compress and expand outward circumferentially, situating the tip assembly **316** into the expanded position. Twisting or rotating the expansion actuator **336** in

a second, opposite direction causes the expansion elements **328** to retract back into tension and lengthen, situating the tip assembly **316** into the retracted position.

[0077] The cutting assembly **318** can be rotatable about the shaft **314**. More specifically, as shown in FIGS. **15A-15B**, the uterine manipulator **300** can include a flexible shaft portion **315** along which the cutting assembly **318** can slide laterally and/or rotated for proper positioning or operation. The cutting assembly **318** can include a cup portion **382** and a cutter or cutter wire **384**. Similar to the cutter **206** of FIG. **13**, the cutter **384** can be formed as a narrow wire, with a looped tip **383**, embedded between grooves (not shown) on the cup portion **382**. In addition, the cup portion **382** can include a projection **385** to assist an operator in locating the cutter **384** during an operation, to help shield the cutter **384** during insertion of the uterine manipulator **300**, and/or to help push the cutter **384** through the vaginal tissue.

[0078] Referring to FIG. **14**, the cutter **206** (or the cutter **384**) is preset in a stored position **212** between the grooves **208, 210** (for example, when the uterine manipulator **100/300** is being inserted into a patient's uterus **114**). The cutter wire can be secured between the grooves **208, 210** by small, thin bridges (not shown) around the edge of the cup portion **202**, with the looped tip of the cutter **206** extending outward from the grooves **208, 210** at a 12 o'clock position. The bridges can be thin enough that they can be easily broken by pulling the cutter **206** against the bridges with sufficient force. The cutter **206** is designed to move from the stored position **212** to an extended position **214** where the cutter **206** can be pushed through the top of the vagina (for example, with the help of the projection **383** of cup portion **382**) after the cup portion **202** has been positioned at a juncture between the cervix **112** and the vagina no (for example, the vaginal fornix **118**). In a further extended position **216**, the cutter **206** can be pulled in by a laparoscopic instrument **218**, or "wand," that is introduced laparoscopically.

[0079] The instrument **218** includes a trocar **220** that extends through the skin **222** to present a handle **224** to a clinician. The instrument **218** also includes a small grasper **217** at its proximal end that can grasp or engage with the looped tip of the cutter **206**. Using the handle **224**, the instrument **218** is directed around the cup portion **202** and, as a result, pulls the cutter **206** at position **226**. As the cutter **206** makes contact with tissue at the juncture of the vagina no and cervix **112**, the tissue is cut, thus separating the vagina no from the cervix **112** and uterus **114**. At a final position **228**, for example, once the cutter **206** has been pulled around the circumference of the cup portion **202**, the cutter **206** can be separated from the cup portion **202**. The laparoscopic instrument, with the entire cutter **206**, can then be removed through a laparoscopic port at the skin **222**.

[0080] The inner groove **210** of the cup portion **202** can be taller than the outer groove **208** to prevent the cutter **206** from being pulled inward (instead of upward or outward) as the instrument **218** pulls the cutter **206**. In addition, the laparoscopic instrument **218** can include an outer insulation cover **219** that is pushed forward while the cutter **206** is pulled out of the grooves **208, 210**. That is, the cutter **206** is pulled into or received in the laparoscopic instrument **218** so that the cutter **206** is covered by the laparoscopic instrument **218** during operation, thereby enhancing safety given that

the cutting wire or blade (which can be carrying electrical current, as described below) is not exposed at any given time.

[0081] The cutter **206** can either cut the vagina without electrical current ("cold") or with an electrical current, based on surgeon preference. For example, a distal end of the laparoscopic instrument **218** can connect to an electrosurgical unit (not shown) or electrical connector assembly, which can conduct monopolar or bipolar current. Accordingly, once the laparoscopic instrument **218** grasps the cutter **206**, current is passed through the instrument **218** and to the cutter wire **206**. Different operations can be conducted based on monopolar or bipolar configurations. For example, in a monopolar configuration, the cutter **206** can be pulled out of the cup portion **202** along its entire circumference and removed via the laparoscopic instrument **218** (as described above with reference to FIG. **14**) while the cup portion **202** remains fixed to a shaft (such as shaft **14** or **314**). More specifically, the cup portion **202** is not rotated about the shaft during this operation. Power during monopolar operation can be relatively high, such as about 100 watts.

[0082] FIG. **16** illustrates a uterine manipulator **400** in accordance with the present disclosure. The uterine manipulator **400** can include a handle assembly **402** coupled to a distal end of a shaft **406**. The handle assembly **402** is discussed further in association with FIG. **18** below. The handle assembly **402** and the shaft **406** can be analogous to the handle **12** and the shaft **14** illustrated in FIGS. **1-2**, respectively. The shaft **406** can be substantially S-shaped. The uterine manipulator **400** can include a sheath **410**, which can slide over and along the exterior surface of the shaft **406**. The sheath can be heat shrunk around the shaft **406**. The uterine manipulator **400** can include a stopper **408** that slides over and along the exterior surface of the shaft **406** and interfaces with the distal end of the sheath **410**. The stopper **408** includes a key **407** that can engage with the shaft **406**. Engaging the key **407** with the shaft **406** can prevent the stopper **408** and the sheath **410** from sliding distally along the exterior surface of the shaft **406**. The stopper **408** and the key **407** are discussed further in association with FIGS. **17A-17B** below.

[0083] The uterine manipulator **400** can include a pneumooccluder **412**, which can slide over and along the exterior surface of the sheath **410**. A filling tube **422** can be coupled to the pneumooccluder **412** and can include fluid inlet **420** for the pneumooccluder **412**. The pneumooccluder **412** and the filling tube **422** can be analogous to the pneumooccluder **20** and the filling tube **88** illustrated in FIGS. **1-2**, respectively. A cup **414** coupled to the sheath **410** at or near the distal end of the sheath **410**. The cup **414** can be configured to be positioned at a juncture between a patient's cervix and vagina. The cup **414** can include a cap **416**. The cap **416** can be coupled to the cup **414** at a distal end of the cup **414**. The cup **414** is discussed further in association with FIGS. **19A-20** below. At least one embodiment does not include the cup **414** and the cap **416**.

[0084] FIG. **17** illustrates the distal portion of a uterine manipulator and the balloon **418** in accordance with the present disclosure. The balloon **418** can be triangular in shape. The triangular shape can mimic the interior contours of a patient's uterus. The triangular shape can be similar to that of an isosceles triangle, for example. The corners **452-1** and **452-2** of the balloon **418**, where the base **453** meets each of the legs **454-1** and **454-2**, can be rounded or cut off to

better mimic the interior contours of a patient's uterus. The balloon **418** can be coupled to a tube **450** at the point **451** where the legs **454-1** and **454-2** of the balloon **418** meet. As shown in FIG. 17 the tube can protrude into the volume of the balloon **418** such that that the distal end of the tube **450** almost contacts the base **453** of the balloon **418**. The tube **450** can include steel. The tube **450** can be coupled to the shaft **406** or comprise the shaft **406**. The balloon can include a thermoplastic polyurethane (TPU) material.

[0085] FIG. 18 illustrates the distal portion of a uterine manipulator and the balloon **418** in accordance with the present disclosure inserted into a patient's uterus **531**. The distal portion of the uterine manipulator, such as the uterine manipulator **400** illustrated in FIG. 16, can be inserted into a patient's uterus **531** via the patient's vagina **540** and cervix **538**. As illustrated in FIG. 18, the corners **452-1** and **452-2** of the balloon **418** can include apertures and/or channels **536**. For example, dye can be injected into the balloon **418** via the channels **536**, such as that used in chromoperturbation in order to determine the patency of one or both fallopian tubes. Because the balloon **418** mimics the interior contours of a patient's uterus **531**, the corners **452-1** and **452-2** can be aligned with the openings of the fallopian tubes **534** with little or no adjustment of position and/or orientation of the inflated balloon **418** in the patient's uterus **531**. Thus, when dye is injected into the balloon **418** the dye flows directly from the corners **452-1** and **452-2** into the openings of the fallopian tubes **534** so as to avoid inadvertent injection of dye into muscular tissue of the uterus.

[0086] As illustrated in FIG. 18, the balloon **418** can include a light source **532**, such as a light emitting diode (LED) or fiber optics. The light source **532**, for example, can be coupled to the tube **450**. The light source **532** can illuminate the interior of a patient's uterus **531**. The light output of the LED (or LEDs) can range from about 100 lumen to about 10,000 lumen, in increments of about one lumen. An array of LED elements can be provided coupled to a controller that can controllably adjust the temperature (e.g., 2700 K to 5000 K in increments of 10K) and/or color of the LEDs to produce, for example, shades of white light of varying warmth by relatively increasing the amount of yellow or blue output of the LEDs. Thus, an LED array having LEDs of different colors (yellowish white to bluish white) can be provided. For example, the array can have three (red, green blue LEDs), four, five, six, seven, eight, nine, ten, eleven or twelve different colors of LEDs to permit color mixing. For example, the controller can create a light output having a peak light output between about 365 nm and about 700 nm in increments of about 5 nm.

[0087] Using visualization from inside a patient's uterus **531** (e.g., using a separate endoscope, using an endoscope disposed along a separate sleeve formed into the shaft, or by using an optic integrated into the balloon, such as a photo-detector array, not show), in addition to or as a component of the uterine manipulator, the endometrial lining of the patient's uterus **531** can be examined, for example, for perforations during a myomectomy. Avoiding undetected perforations in the endometrium can increase patient safety and/or the fertility of the patient. If the light source has a high intensity, a patient's uterus can be illuminated internally but visualized externally to, for example, identify and/or locate fibroids, such as the fibroid **530**. Such external visualization can be accomplished, for example, but introducing an endoscope into an insufflated abdominal cavity.

The camera of the endoscope can thus view light originating from within the uterus and shining through the tissue of the uterus.

[0088] FIG. 19A illustrates a partial perspective view of the uterine manipulator **400** of FIG. 16. As shown in FIG. 19A, the shaft **406** can include a groove **432**. The groove **432** can run along a portion of the shaft **406** beginning at the proximal end of the shaft or the full length of the shaft **416**. The groove **432** can be used to orientate rotationally at least one component of the uterine manipulator **400**, such as the handle assembly **402** or the cup **414**. The key **407** can engage with the shaft **406** via a protrusion **431** of the key **407** that fits in the groove **432**. The stopper **408** can have a sloped distal end.

[0089] FIG. 19B illustrates a cross-sectional view of the stopper **408** and the key **407** of FIG. 16. As shown in FIG. 19B the shaft **416** interfaces the stopper **408** via a gasket **434**. The gasket **434** can prevent liquid/gas leaks from the sheath **410**. The proximal end of the sheath **410** interfaces with the distal end of the stopper **408**. As shown in FIG. 19B, the shaft **416** can include a channel **433**. The channel of the shaft **406** can, for example, transport fluid to inflate the inflatable balloon **418**. The key **407** can include a protrusion **435** that engages the shaft **406** via the groove **432**.

[0090] FIG. 20 illustrates a cross-sectional view of the handle assembly **402** of FIG. 16. The handle assembly **402** can include a fluid inlet **404**, which can be located at the proximal end of the handle assembly **402**. The handle assembly **402** can include a proximal portion of the shaft **402** illustrated in FIG. 16. As shown in FIG. 20, the proximal end of the shaft **406** can be coupled to a locking block **436**. An inlet tube (not shown) can be coupled to the locking block **436** and the fluid inlet **404**. The locking block **436** can include a channel to allow fluid and/or other equipment (e.g., a stylet) to pass through the fluid inlet **404**, the inlet tube, and the locking block **436** and into the shaft **406**. The handle **435** can surround at least a portion of the fluid inlet **404**, the inlet tube, the locking block **436**, and the shaft **406**. Although not shown in FIG. 20, the handle assembly **402** can include apertures and/or channels for wires **450-1** and **450-2** illustrated in FIG. 22.

[0091] Although not illustrated in FIG. 20, the handle assembly **402** can include a trigger. The trigger can be coupled to a needle in the cup **414** as described in association with FIG. 16 above. The needle in the cup **414** can be used to introduce the wire.

[0092] FIG. 21A illustrates a perspective view of the cup **414** of FIG. 16. The cup **414** can have a conical shape. The distal end of the cup **414** includes an interface **440** for the cap **416** illustrated in FIG. 16. The cup **414** is configured to interface with a patient's cervix.

[0093] FIG. 21B illustrates another perspective view of the cup **414** of FIG. 16. The cup **414** can include aperture **446** through which the shaft **416** can pass through. As shown in FIG. 21B the cup **414** can include apertures **442-1** and **442-2** for passing wires through for powering a cutting head (discussed further in association with FIG. 21 below) or for any other desired purpose.

[0094] FIG. 21C illustrates a cross-sectional view of the cup **414** of FIG. 16. As shown in FIG. 21C, the aperture **446** can include a first diameter **447** for the shaft **406** and a larger second diameter **448** (e.g., a counter bore) for a sheath **410** illustrated in FIGS. 16 AND 22. The aperture **446** can include a projection **445** that can fit into the groove **432**

illustrated in FIG. 19A to maintain proper orientation of the cup 414 relative to the shaft 406.

[0095] FIG. 22 illustrates a distal portion of the uterine manipulator 400 of FIG. 16. The pneumooccluder 412 the cup 414 are shown as see-through. However, embodiments are not limited to the pneumooccluder 412 and/or the cup 414 including a transparent material. In at least one embodiment, the uterine manipulator 400 can include a heat shrink sleeve 452 that surrounds the sheath 410 from the stopper 408 to the cup 414. As shown in FIG. 22 wires 450-1 and 450-2 pass through apertures in the stopper 408, run adjacent to the heat shrink sleeve 452, pass under the pneumooccluder 420, and pass through the apertures 442-1 and 442-2, respectively. It will be appreciated that conductors/wires can be routed in other manners.

[0096] In a bipolar configuration, the cutter 206 can be a shorter wire than the monopolar configuration, for example, about 2 centimeters (cm) to about 3 cm. The cutter 206 can be pulled through the vaginal tissue by the laparoscopic instrument 218, remaining at the 12 o'clock position, and then the cup portion 202 can be rotated about the shaft as the cutter 206 is held in place. One pole of the bipolar current can be through the laparoscopic instrument 218 (connected to the cutter wire 206) and the other pole can be through the cup portion 202.

[0097] In at least one embodiment, the shorter cutter 206 can be held between the grooves 208, 210 by a small ball (not shown) at a distal end of the cutter 206. The ball can help the cutter 206 slide around the circumference of the cup portion 202 but also prevents the entire cutter 206 from being pulled out from between the grooves 208, 210 as the laparoscopic instrument 218 pulls the cutter 206. Once the cutter 206 has traversed the entire circumference of the cup portion 202, a break or opening (not shown) between the grooves 208, 210 can allow the ball to be pulled out from the cup portion 202 and into the laparoscopic instrument 218 for removal. This ball configuration can be used with bipolar or monopolar applications. In bipolar applications, a small metal lining inside of the grooves 208, 210 can electrically connect the cup portion 202 to the ball (which is electrically connected to the laparoscopic instrument 218).

[0098] The uterine manipulator 10, 300, 400, or at least one or more components of the uterine manipulator 10, 300, can be used with orifice-assisted small incision surgeries (OASIS). In such surgeries, instrumentation can be inserted through a patient's belly button as well as the patient's vagina 110. The optical axis (e.g., of a laparoscope inserted through the belly button) can be decoupled from the operative axis (e.g., of a surgical tool inserted through the vagina 110). The uterine manipulator 10, 300 can include an extension tool to assist with OASIS procedures.

[0099] FIGS. 23-25 illustrate an embodiment of a cutting head that is suitably configured for use with the uterine manipulators disclosed herein, or other uterine manipulators or other medical devices that utilize, or can be modified to utilize, an electrosurgical cutter. It will also be appreciated by those of skill in the art that the disclosed cutting head can be used in a variety of other procedures other than procedures separating the uterus from the vagina, such as bowel resections, gastric bypass procedures and any other procedure that requires separation of biological structures having a tubular or ring shaped component to be cut.

[0100] For purposes of illustration, and not limitation, FIG. 23 illustrates a partial side view of a cutting assembly

500 in accordance with the present disclosure. The cup 506 can be configured to be positioned at a juncture between a patient's cervix and vagina. The cutting assembly 500 can include a cutting wire 512. As illustrated in FIG. 23, the cutting wire 502 can pass through an aperture of the cup 506. The cap 502 can include an electrically insulating material disposed thereon (e.g., parylene, or other suitable material). The cutting wire 512 can contact (rest against) the electrically insulating material on the cap 502. The cutting assembly 500 can include a projection 501 that initially pushes the cutting wire 512 through the tissue when the cup 506 is positioned at the juncture between the cervix and the vagina.

[0101] The cutting wire 512 can be used to cut the vagina without electrical current ("cold") or with an electrical current ("hot"), based on surgeon preference. Different operations can be conducted based on monopolar or bipolar configurations. Power during monopolar operation can be relatively high, such as about 100 watts. As the cutting assembly 500 rotates about the shaft 406, the cutting wire 512 follows a substantially circular path thereby separating a patient's uterus and cervix from the vagina.

[0102] FIG. 24 illustrates a perspective view of a cap 502 of the cutting assembly 500 of FIG. 23. The cap 502 can include a base 514 and an electrically insulating (e.g., plastic, parylene) coating 508. The base 514 can include an electrically conductive material, such as a stainless steel foil. The electrically insulating coating 508 can be bonded to a surface of the base 514. The base 514 can include one or more tabs 512-1, 512-2, and 512-3 for coupling the cap 502 to an interior surface of the cup 506 as discussed further in association with FIG. 25 below. The tabs 512-1, 512-2, and 512-3 can include an aperture through which a fastener (e.g., a screw) can pass.

[0103] FIG. 25 illustrates a perspective view of a cutting assembly 550 of a uterine manipulator in accordance with the present disclosure. The cutting assembly 550 can include a cup 554 and a cap 556. The cup 554 and the cap 556 can be analogous to the cup 506 and the cap 502 illustrated in FIG. 23, respectively. Fasteners 552-1, 552-2, and 552-3 can couple the cap 556 to the interior surface of the cup 554 through apertures in the tabs 512-1, 512-2, and 512-3. A cutting wire 512 can be coupled to one of the fasteners, such as the fastener 552-3. For example, the cutting wire 512 can be coupled to an eyelet (not shown). The eyelet can be placed around the fastener 552-3. An electric current can be applied to the cap 556 (e.g., to an electrically conductive material of the base 514 described above). The cap 556 can include electrically insulating material to prevent harm and/or injury to a patient from the electric current. The cutting wire 512 can include a looped tip, which can be used to engage a laparoscopic instrument. As indicated by the double-headed arrows in FIG. 25, the cutting assembly 550 can rotate, clockwise and/or counterclockwise. As the cutting assembly 550 rotates, for example about the shaft 406, the cutting wire 512 follows a substantially circular path thereby separating a patient's uterus and cervix from the vagina.

[0104] FIG. 26A is a side view of a further representative embodiment of a uterine manipulator in accordance with the present disclosure, and FIG. 26B is an enlarged view of the distal end as presented in FIG. 26A.

[0105] As illustrated, the uterine manipulator 600 bears a number of similarities to previous embodiments, including a triangular balloon connected to an actuator 620 housed within a distal cup. It will be appreciated that structures

other than a triangular balloon can be used. Focusing on the distal end portion 650 of the manipulator 600, FIG. 26B illustrates a side view of a cup that has been configured to provide a bipolar cutting mechanism discussed in further detail below. It will be appreciated that instead of providing a bipolar arrangement including a conductive ring 690 and a return conductor 668, this design can be modified to be a monopolar cutting head by removing those components and making other suitable modifications. FIG. 27A is a side cut away view of the embodiment of FIGS. 26A-26B, wherein FIG. 27B is an enlarged view of the distal end as presented in FIG. 27A showing the location of components discussed in particular detail below.

[10106] With reference to FIG. 28, a close up cross sectional view of the distal end portion of the uterine manipulator presented in FIG. 26A is presented. Distal end portion 650 includes a cutting head formed by a stationary cup, as opposed to a rotating cup in the preceding embodiment. Procedurally, a hot lead is deployed and advanced by a push wire (e.g., made of stainless steel) through the vaginal wall where it intersects the cervix. The hot wire is externalized so it can be viewed laparoscopically within the abdominal cavity, and where it can be gripped and pulled around (e.g., with forceps or other tool) around the circumference of the distal cup. This avoids the use of a rotating cutting head, and wire that is pre-packed into the distal cutting head is externalized and pulled through as the circumference of the cervix is traversed. Cutting is achieved with the aid of an arc discharge that is present in a toroidal gap (e.g., 692) defined between the hot wire 660 and a conductive ring 690 as the hot wire is pulled around the circumference of the cervix.

[10107] Thus, the components illustrated in FIG. 28, and later figures, include the distal cutting head 650 that terminates in an annular, or toroidal, distal cap 654 that preferably includes a coating of insulating material on its proximally and/or distally oriented faces. Beneath the cap within the distal cup is defined an annular trench, or channel, that is configured to receive a conductive ring 690. Ring 690 may be a discrete metallic component or may be metallized on a plastic surface. Ring 690 essentially sits in a trough having a radially outwardly located lip that extends upwardly from the bottom of the trough, preferably made from a dielectric material. The radially outwardly located lip cooperates with the circumferential periphery of the distal cap to define an annularly shaped groove therebetween that can permit cutting wire 660 to be drawn through as the device is used to make a 360 degree cut to separate the cervix from the vagina. It will be appreciated that the groove could be slightly less than 360 degrees, if desired, to enhance structural stability. In use, once deployed, the conductive hot lead 660 is pulled radially outwardly through and along the annularly shaped groove. As this happens and power is applied to the hot lead and a return path is defined along ring 690 and conductor 668 (see FIG. 37B), a space always exists between the hot lead 660 and the conductive ring 690. When the applied electric field is sufficiently high, current will flow across the gap 692 from the wire 660 to the ring 690. In the process of doing this, a plasma may or may not be formed locally (depending on the voltage and pulse shape of the applied waveform) which can provide enhanced benefits of reactive oxygen species (ROS) and the like, as well as generally providing the benefits of electrocautery effects to minimize bleeding from the vaginal wall and the severed cervix/uterus.

[10108] As illustrated, conductor 660 terminates in a cuff 680 that is in turn engaged by a distal tip 672 of a push rod 670. End cap 654 defines an elongate opening therein that is disposed along a radial direction. The elongate opening is configured to permit the push rod 670 to pass through it, carrying the cuff 680 and a distal end 664 of the hot lead or conductor 660. While a proximal end of the hot lead 660 is shown not extending proximally to the proximal end of the device, this is to simplify illustration. In operation, the proximal lead 660 either extends through the proximal end of the device or follows a conductive path through the proximal end of the device 600 where it is connected to a hot lead of a suitable electrosurgical signal generator, or power supply (not shown). Likewise, the lead 668 (FIG. 37B) also extends through the proximal portion of the device 600 and is electrically coupled to a return terminal of the signal generator/power supply to complete the bipolar circuit, and avoiding the need for a grounding pad, thereby minimizing the amount of electrical energy directed through a patient. Likewise, although not specifically illustrated in the drawings, the push rod 670 also extends proximally to an actuator, not shown, to permit it to be moved distally and proximally with respect to the device to deploy the hot wire.

[10109] FIGS. 29A, 29B and 29C are a partial section isometric end view, a partial side section view and a full section view of the distal end portion of the uterine manipulator presented in FIG. 26A with the cutting wire partially deployed.

[10110] As illustrated in FIG. 29A, the hot wire 660 can be folded in and/or doubled over along the path of the annular gap 692, but preferably located radially inwardly. In operation, FIG. 28 shows the hot wire 660 in a pre-deployed condition, wherein the hot wire is located, or wrapped inside of, the annular gap, and extends radially outwardly from the gap, and wrapped over the radially outwardly solid portion of the end cap 554 that is defined in part by the radially oriented opening through the end cap. The hot wire 660 then wraps proximally and is received by the cuff 680, which is removably attached to the distal tip 672 of the push rod 670. The push rod 670 (which may be made from stainless steel, for example) is then advanced distally out of the radially oriented gap defined through the end cap, pulling along the distal end 664 of the hot lead 660 through the gap. As illustrated, the push rod can have a pre-formed curvature that causes it to bend radially outwardly, to pierce tissue near the cervix and pass radially outwardly into the abdominal cavity. While surrounding tissue is not illustrated, it will be appreciated that when the wire 660 has been pushed through the tissue into the abdominal cavity by the push rod 670, it will become visible to a surgeon that is viewing within the abdominal cavity after insufflation using an endoscope and a lighting device through a trocar.

[10111] FIGS. 30A, 30B and 30C are a partial section isometric end view, a partial side section view and a full section view of the distal end portion of the uterine manipulator presented in FIG. 26A with the cutting wire partially deployed and the push wire retracted into the device after advancing the hot lead through tissue.

[10112] FIGS. 30A-30C illustrate the hot wire lead 660 and cuff 680 left in a position that is externalized in an abdominal cavity (without illustrating surrounding tissue for clarity). The push rod 670 is withdrawn back into device 600. This permits a surgeon to then grip the cuff 680 (which may be made from insulating material or with an insulating

coating) to then pull the wire around the circumference of the annular gap, either cold (without applied electrical power), or hot (with applied electrical power). FIG. 31 is an isometric end view of the distal end portion of the uterine manipulator presented in FIG. 26A with the hot lead partially deployed as in FIGS. 30A, 30B and 30C prior to being gripped by a surgeon to cut tissue along a circumferential direction. FIG. 31 also illustrates a portion 352 of the cup that can be removable, or permanently attached, to help locate the conductors in place, if desired. This segment is further illustrated in FIGS. 32A-32B which are outer and inner isometric views of a segment of the distal end portion of the uterine manipulator presented in FIG. 26A with the hot lead partially deployed as in FIGS. 30A, 30B and 30C.

[0113] FIGS. 33A-33B are outer and inner isometric views of the distal end portion 650 of the uterine manipulator 600 presented in FIG. 26A with the portion illustrated in FIGS. 32A-32B removed with the hot lead 660 partially deployed as in FIGS. 30A, 30B and 30C to illustrate relative placement of components. Similarly, FIGS. 34A-34B are upwardly directed isometric and side cutaway isometric close up views of segments of the distal end portion 650 of the uterine manipulator 600 presented in FIG. 26A with the portion illustrated in FIGS. 32A-32B removed with the hot lead 660 partially deployed as in FIGS. 30A, 30B and 30C.

[0114] Moving along through an illustrative procedure, FIG. 35 is an isometric section view of the distal end portion 650 of the uterine manipulator 600 presented in FIG. 26A with the hot lead 660 fully deployed along a radially outward direction with tension applied thereto at cuff 680 through various means, such as a forceps (not illustrated) and positioned to cut through tissue to separate a cervix and uterus from a vaginal wall. FIG. 36 is a side section view of the distal end portion 650 of the uterine manipulator 600 presented in FIG. 26A with the hot lead 660 fully deployed and positioned to cut through tissue to separate a cervix and uterus from a vaginal wall. FIG. 37A is an isometric close up section view of the distal end portion 650 of the uterine manipulator 600 presented in FIG. 26A with the hot lead 660 fully deployed and positioned to cut through tissue to separate a cervix and uterus from a vaginal wall. FIG. 37B is an isometric close up section view of the distal end portion 650 of the uterine manipulator 600 presented in FIG. 26A showing a cutaway portion of the distal cup opposite the hot lead 660, illustrating a further portion of the conductive ring 690 connected to the further electrical conductor 668 for providing a return path for applied power as described above.

[0115] FIG. 38A is a further isometric close up section view of the distal end portion of the uterine manipulator presented in FIG. 26A with the hot lead fully deployed and positioned to cut through tissue to separate a cervix and uterus from a vaginal wall.

[0116] FIG. 38B is a further side close up sectional view of a distal end portion 650 of the uterine manipulator 600 presented in FIG. 26A with the hot lead 660 fully deployed and positioned to cut through tissue to separate a cervix and uterus from a vaginal wall, specifically illustrating a portion of a ring-shaped, or toroidal gap 692 defined between the hot lead 660 and the conductive ring 690 attached to a return conductor 668. FIGS. 39A-39B illustrates the ring shaped end cap 654 of the uterine manipulator presented in FIG.

26A illustrating the opening 656 therein for accommodating passage of a push wire in accordance with the present disclosure.

[0117] It will be appreciated the cutting head of FIGS. 28-39 can be suitably combined with any of the features present in the earlier embodiments of the present disclosure. Stated another way, any of the embodiments of FIGS. 1-22 can be modified to include the cutting head of FIGS. 28-39.

[0118] The present disclosure has described one or more preferred embodiments. However, it should be appreciated that many equivalents, alternatives, variations, and modifications, aside from those expressly stated, are possible and within the scope of the invention.

What is claimed is:

1. A uterine manipulator, comprising:

- a shaft including a proximal end, a distal end, and a channel along a longitudinal axis of the shaft;
- a handle coupled to the proximal end of the shaft; and
- a cutting head attached to the distal end of the shaft adapted to cut a tissue segment to separate a vagina from a cervix and uterus, the cutting head including:
  - a cup coupled to the distal end of the shaft and configured to be positioned at a juncture between the cervix and a vagina, the cup including a metal ring coupled thereto, the metal ring being coupled to a return path conductor that leads toward a proximal end of the uterine manipulator; and
  - a cutting wire coupled to the cup via an aperture in the cup such that a portion of the cutting wire extends away from an exterior surface of the cup, the cutting wire being configured to follow a substantially circular path about the longitudinal axis of the shaft when cutting through tissue to separate the cervix from the vagina, and the cutting wire being configured and arranged to traverse a circumference of the distal portion of the cup along a groove defined between a distal end cap of the cup and a proximal frame portion of the cup.

2. A system comprising the uterine manipulator of claim 1, and a power source coupled to the cutting wire to apply electrical current to the cutting wire.

3. The system of claim 2, wherein the uterine manipulator and power source are configured and arranged to provide monopolar current to a patient.

4. The system of claim 2, wherein the uterine manipulator and power source are configured and arranged to provide bipolar current to a patient.

5. The uterine manipulator of claim 1, wherein the uterine manipulator further comprises a push wire slidably disposed along the uterine manipulator, wherein a distal end portion of the push wire is configured and arranged to carry a distal portion of the cutting wire outwardly from a distal end portion of the manipulator.

6. The uterine manipulator of claim 5, wherein the push wire is configured to traverse an opening defined through an end cap of the distal end portion of the uterine manipulator.

7. The uterine manipulator of claim 6, wherein the cutting wire is loaded into a distal end portion of the manipulator, and further wherein distal advancement of the push wire carries the cutting wire distally and radially outward with respect to a distal end of the uterine manipulator.

**8.** A method of separating a uterus from a vagina of a patient, comprising:

providing the uterine manipulator of claim 1;  
inserting a distal end portion of the uterine manipulator through a cervix of the patient; and  
deploying the cutting wire through the tissue of the vagina and/or cervix outwardly into an abdominal cavity of the patient.

**9.** The method of claim 8, further comprising visualizing the cutting wire in the abdominal cavity through a laparoscopic procedure including insufflating the abdominal cavity of the patient, and visually locating a portion of the cutting wire extending into the abdominal cavity.

**10.** The method of claim 9, further comprising grasping the cutting wire using a second surgical instrument from within the abdominal cavity, and pulling the wire circumferentially around the cervix to sever the uterus and/or cervix from the vagina.

**11.** The method of claim 10, wherein the cutting is accomplished without application of electrical current to the uterine manipulator.

**12.** The method of claim 10, wherein the cutting is accomplished with application of electrical current to the uterine manipulator.

\* \* \* \* \*

专利名称(译)	带切割头的子宫机械手		
公开(公告)号	<a href="#">US20190216505A1</a>	公开(公告)日	2019-07-18
申请号	US16/368457	申请日	2019-03-28
[标]发明人	MEADE JOHN C		
发明人	MEADE, JOHN C.		
IPC分类号	A61B17/42 A61B17/00 A61B90/30		
CPC分类号	A61B17/4241 A61B17/00234 A61B90/30 A61B2017/4225 A61B2017/00557		
优先权	62/548252 2017-08-21 US		
外部链接	<a href="#">Espacenet</a> <a href="#">USPTO</a>		

摘要(译)

子宫操纵器可包括轴，该轴包括第一端，第二端，以及切割头的实施例，切割头构造和布置成接收子宫颈。切割头可以被配置并适于用于切割将阴道壁连接到子宫颈和子宫的组织，以便于以微创方式移除子宫。

