



US 20170035408A1

(19) **United States**

(12) **Patent Application Publication**
Scott et al.

(10) **Pub. No.: US 2017/0035408 A1**
(43) **Pub. Date: Feb. 9, 2017**

(54) **SYSTEM FOR INTRA-ABDOMINALLY MOVING AN ORGAN**

Publication Classification

(71) Applicant: **Freehold Surgical, Inc.**, New Hope, PA (US)

(51) **Int. Cl.**
A61B 17/02 (2006.01)
A61B 17/04 (2006.01)

(72) Inventors: **J. Stephen Scott**, Wentzville, MO (US);
Jeffrey Smith, New Hope, PA (US)

(52) **U.S. Cl.**
CPC *A61B 17/0218* (2013.01); *A61B 17/0401* (2013.01); *A61B 17/0466* (2013.01); *A61B 17/0487* (2013.01); *A61B 2017/0417* (2013.01); *A61B 2017/0448* (2013.01); *A61B 2017/0461* (2013.01); *A61B 2017/0464* (2013.01); *A61B 2017/0496* (2013.01)

(73) Assignee: **Freehold Surgical, Inc.**, New Hope, PA (US)

(21) Appl. No.: **15/298,144**

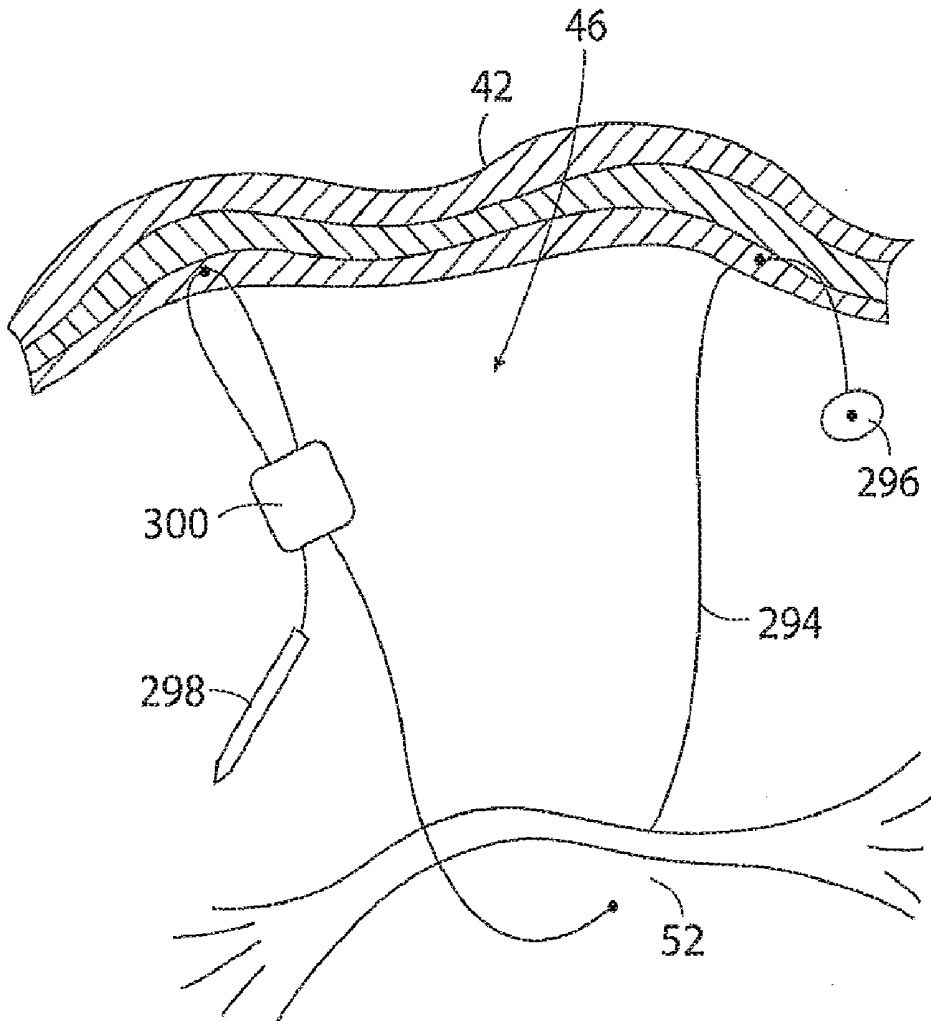
(57) **ABSTRACT**

(22) Filed: **Oct. 19, 2016**

A surgical tissue connector system for moving a first internal body tissue to a position away from a second internal body tissue and then holding the first internal body tissue in the position. Tissue connectors are secured to cords such that the length of cord between the tissue connectors can be easily adjusted in a laparoscopic work space.

Related U.S. Application Data

(63) Continuation of application No. 14/240,928, filed on Feb. 25, 2014, filed as application No. PCT/US2011/001494 on Aug. 25, 2011.



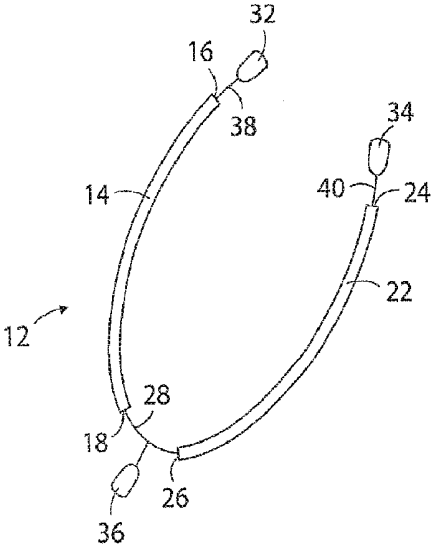


FIG. 1

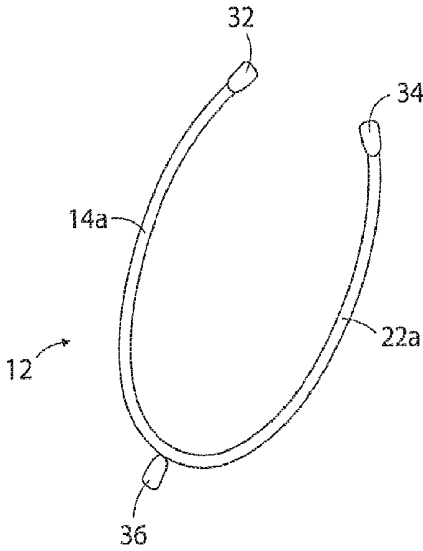


FIG. 2

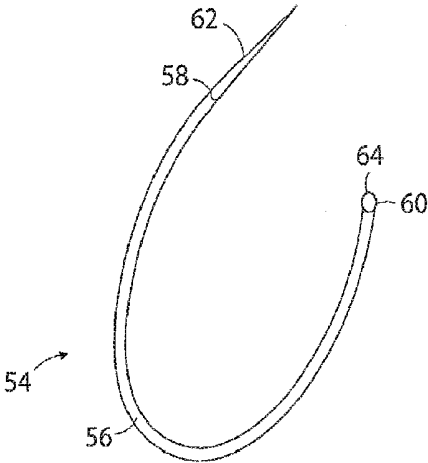


FIG. 3

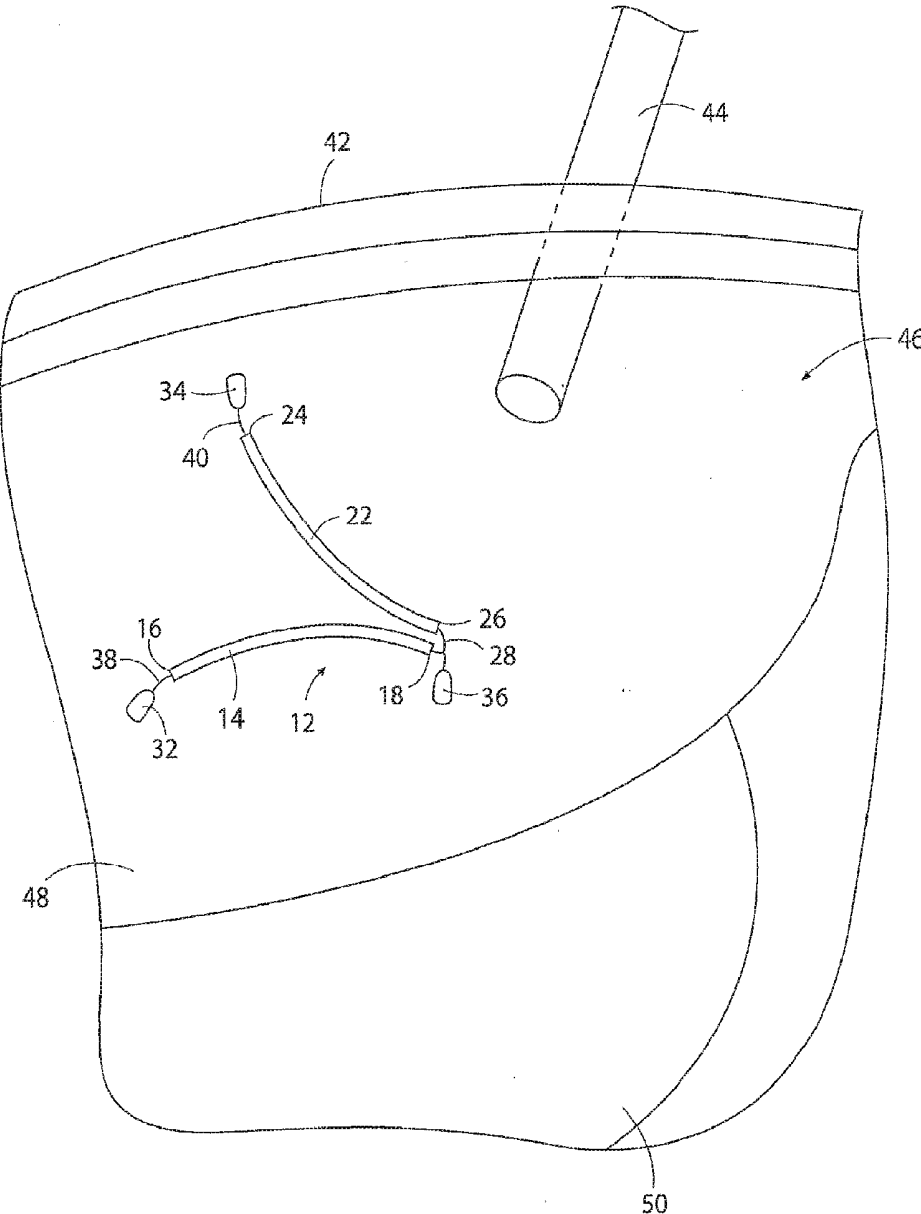


FIG. 4

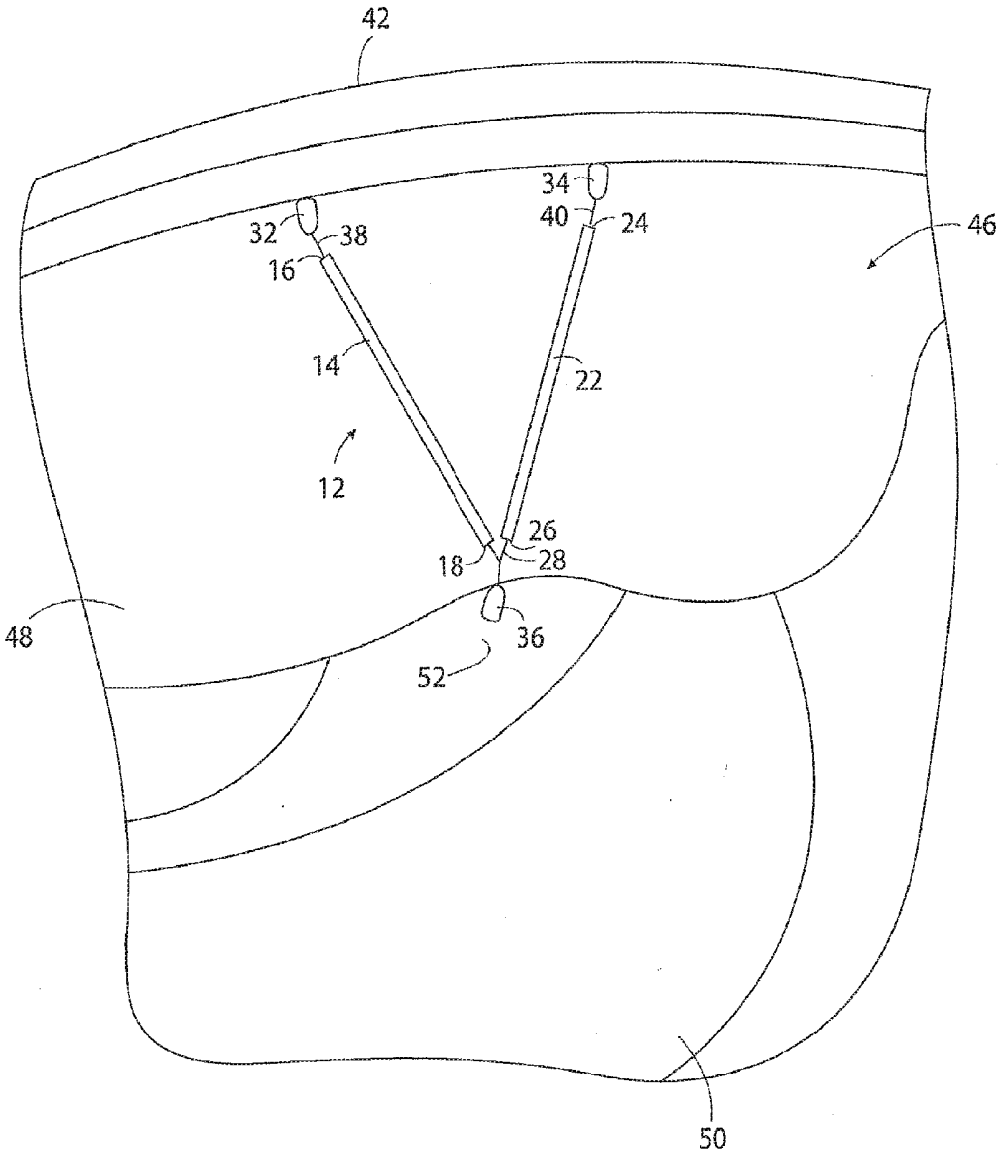


FIG. 5

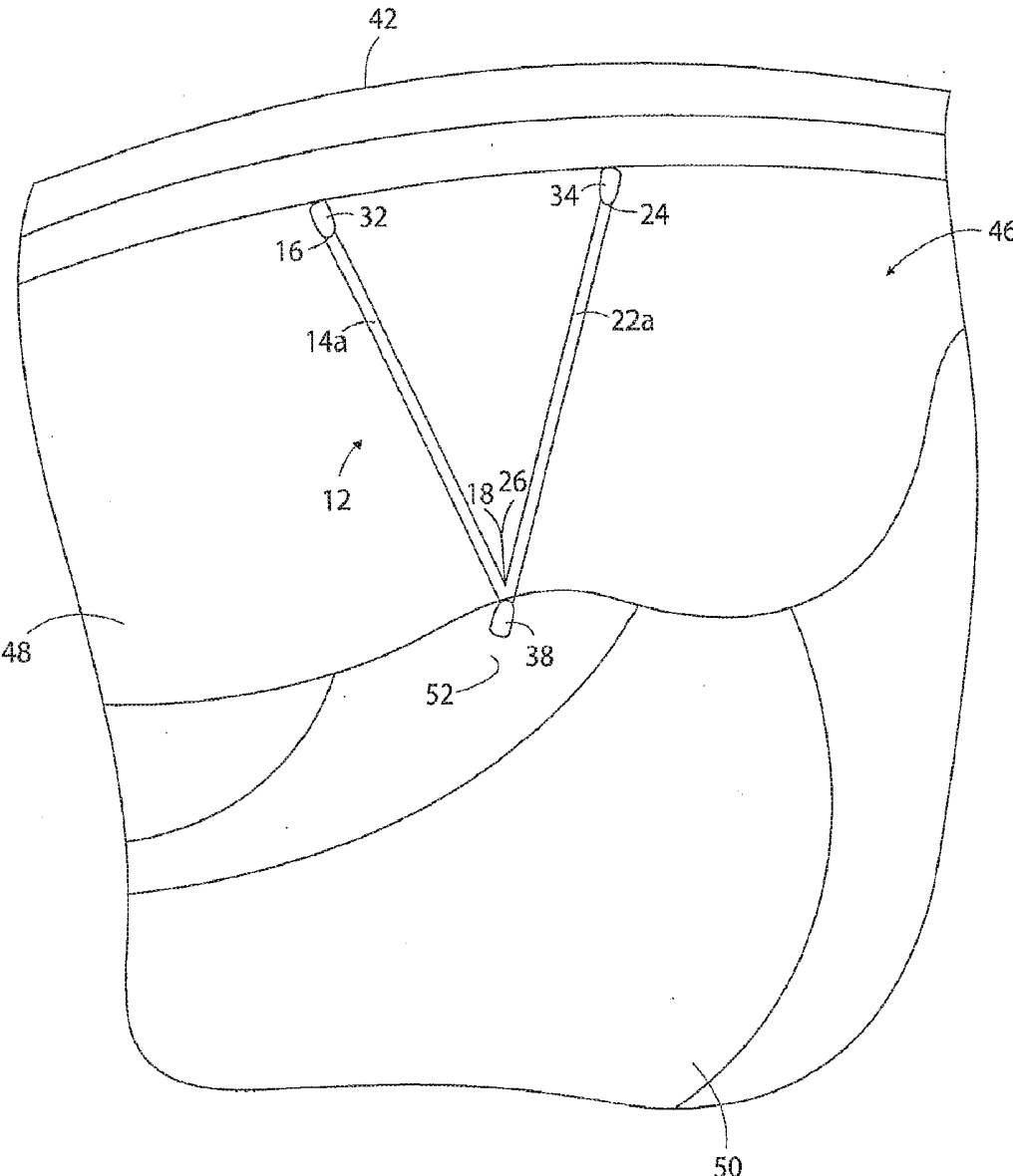


FIG. 6

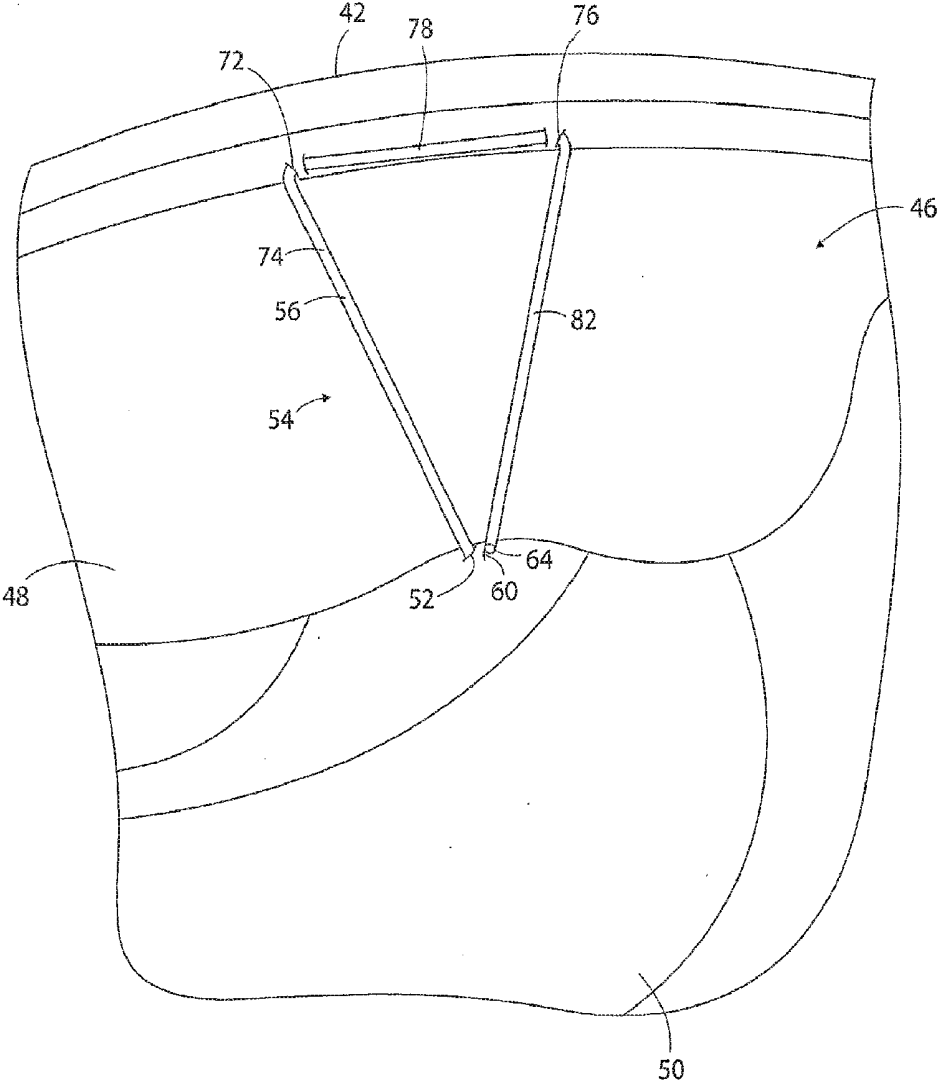
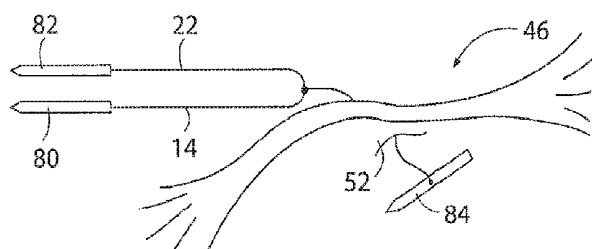
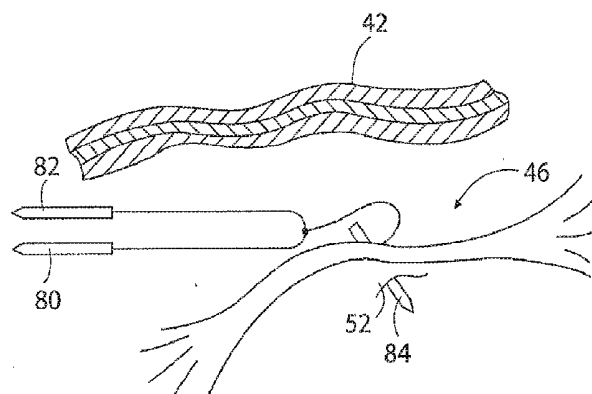
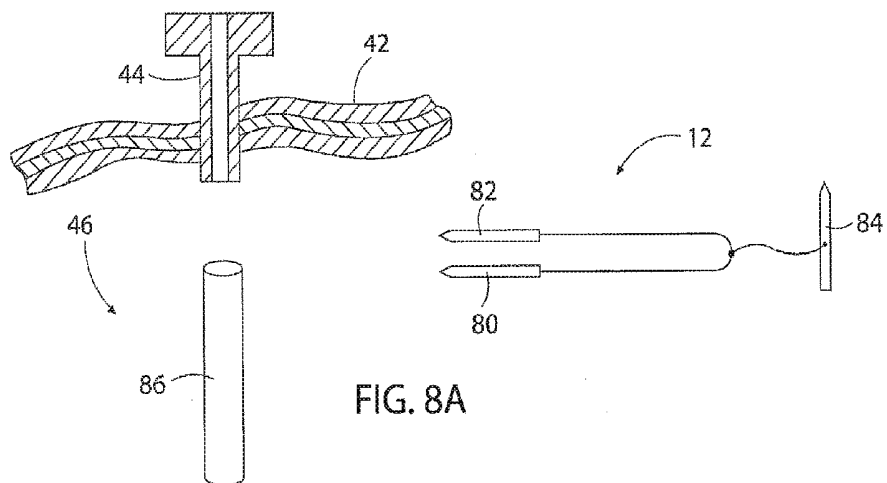


FIG. 7



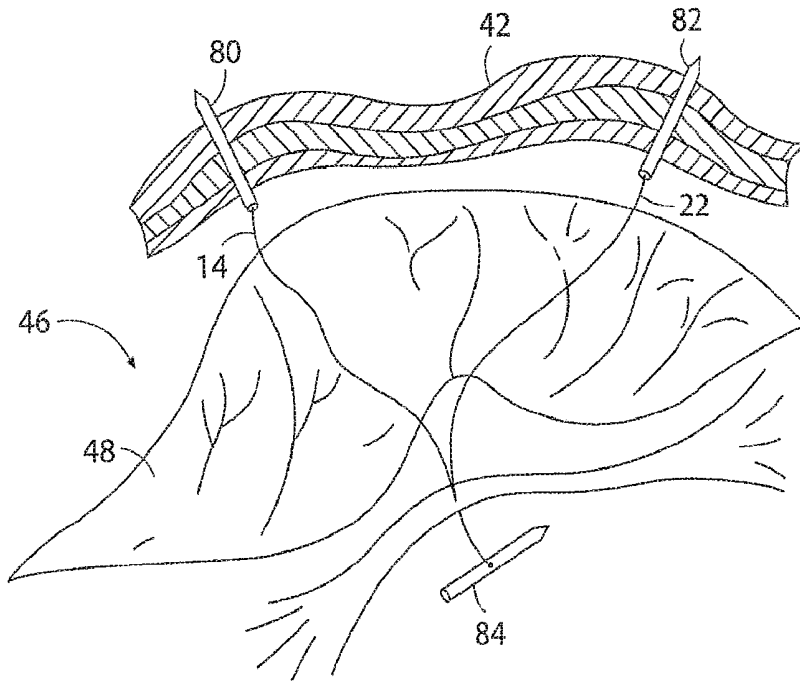


FIG. 8D

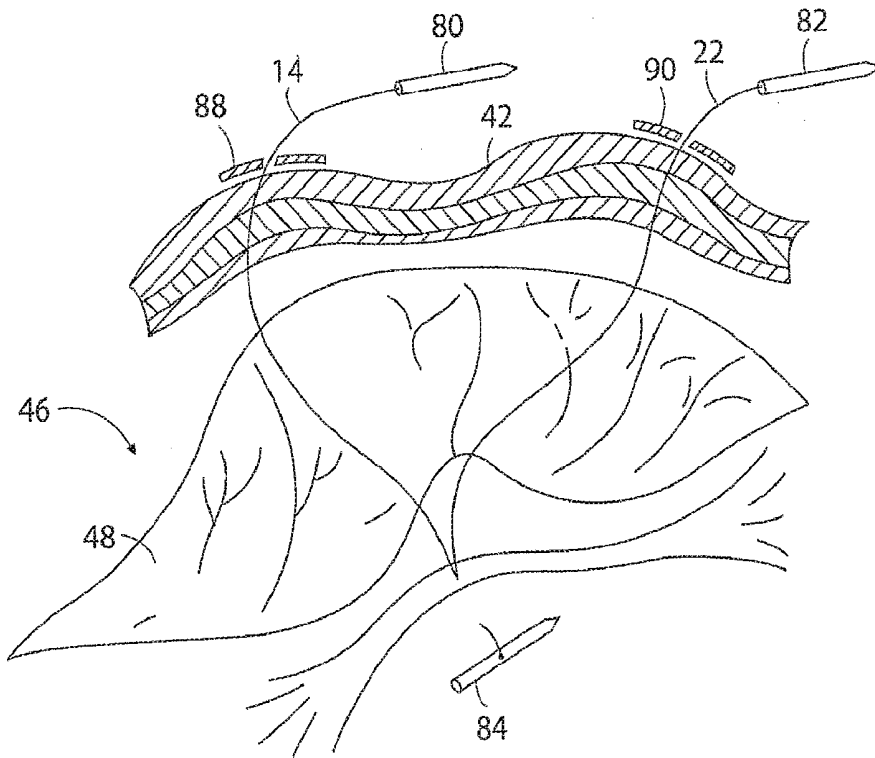
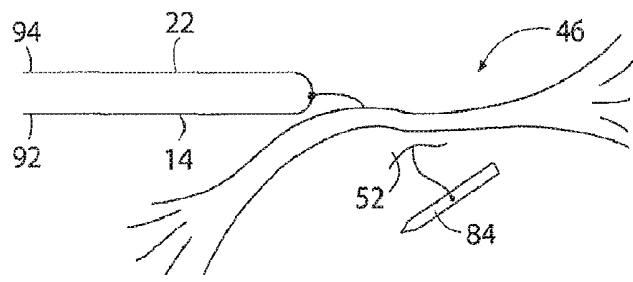
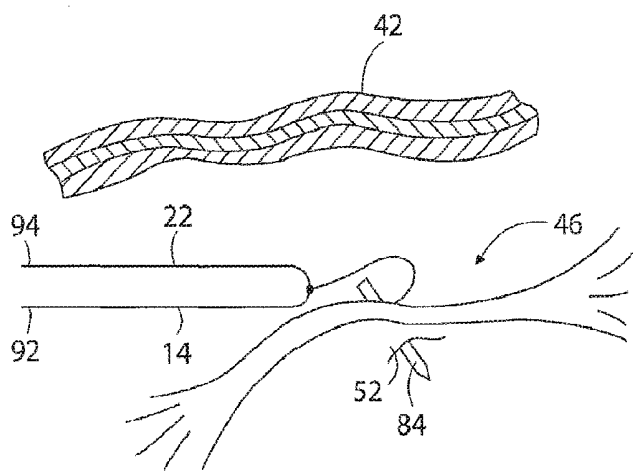
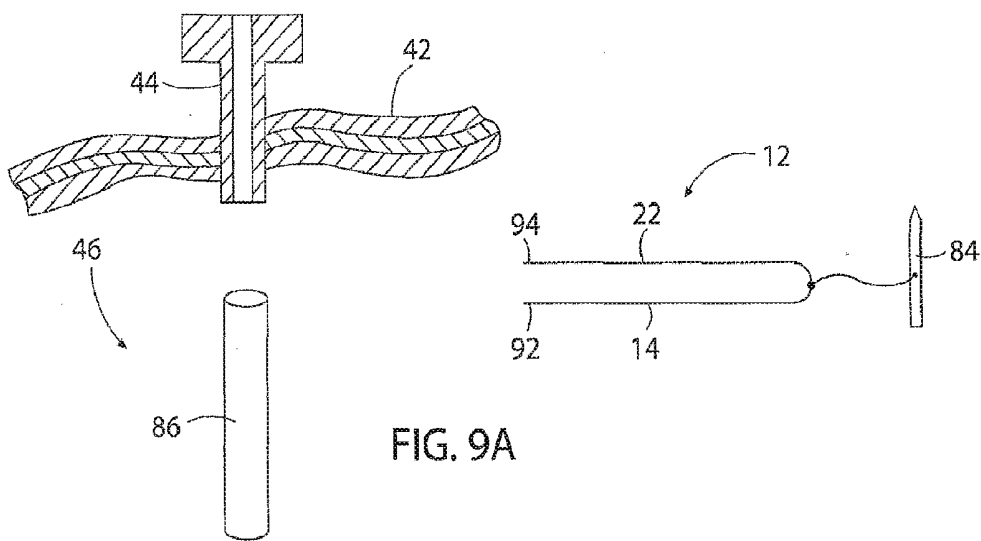


FIG. 8E



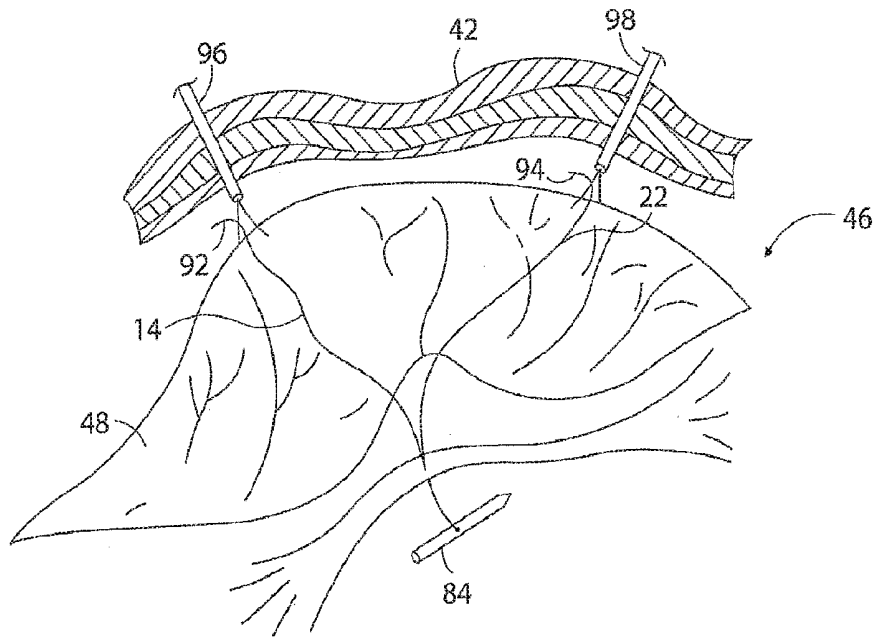


FIG. 9D

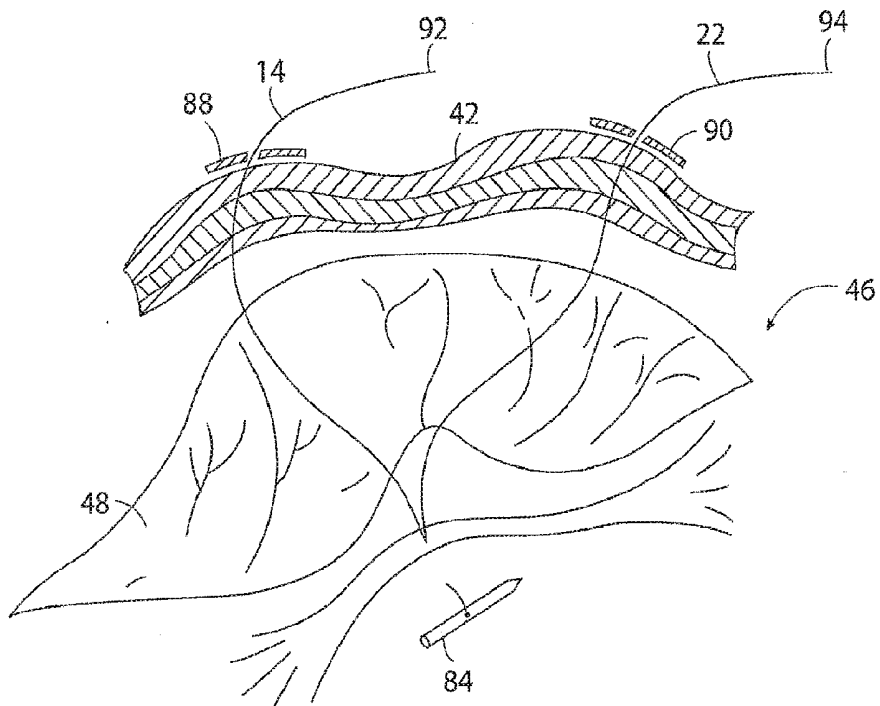


FIG. 9E

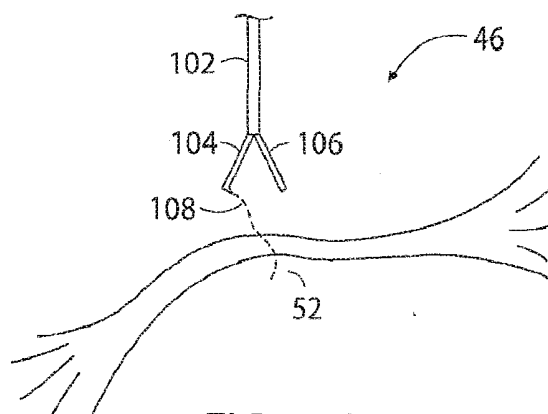
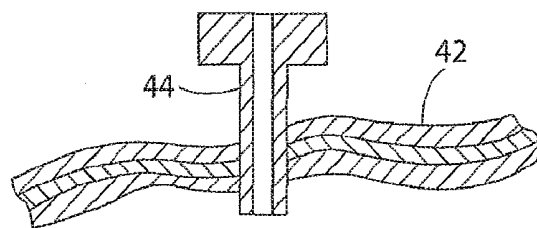


FIG. 10A

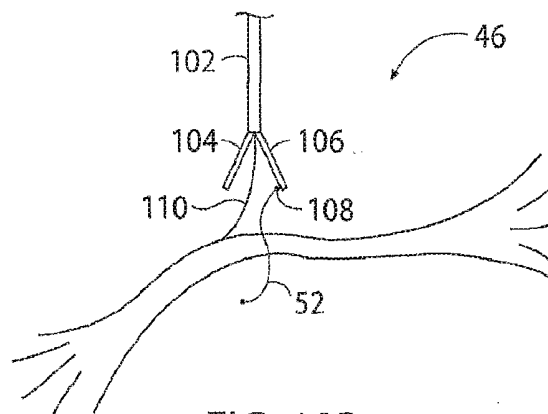
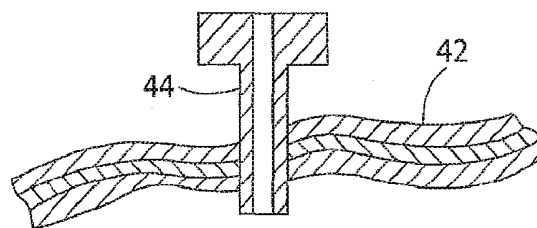


FIG. 10B

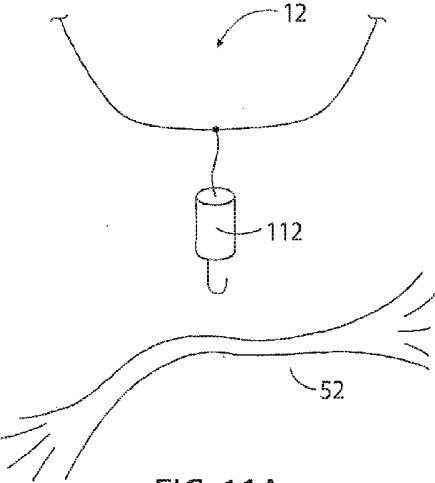


FIG. 11A

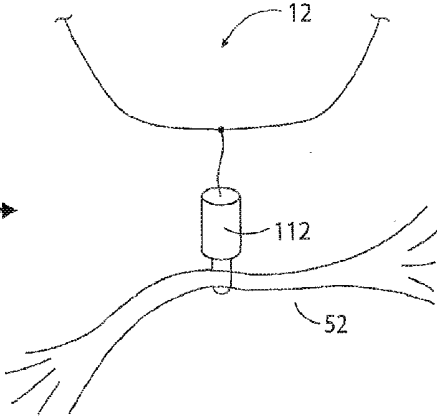


FIG. 11B

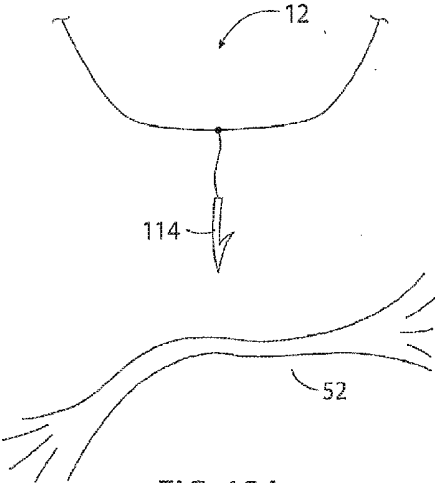


FIG. 12A

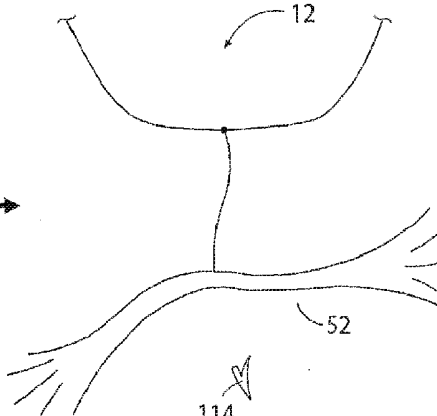
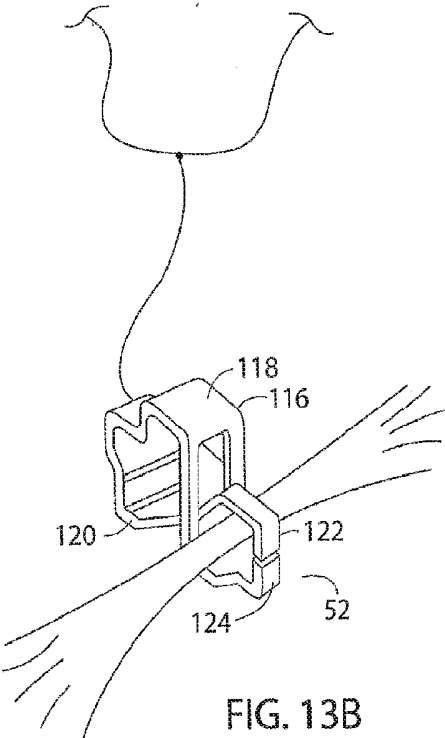
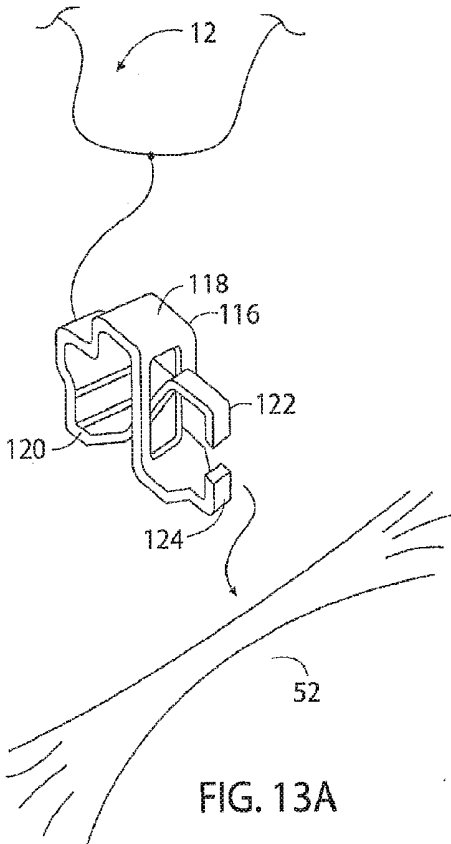


FIG. 12B



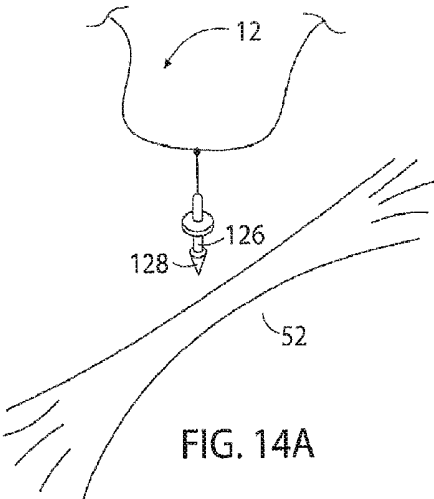


FIG. 14A

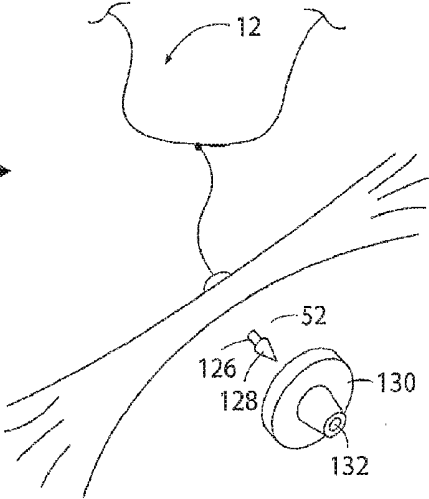


FIG. 14B

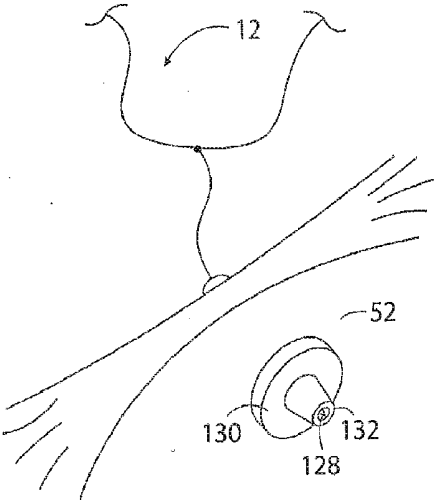


FIG. 14C

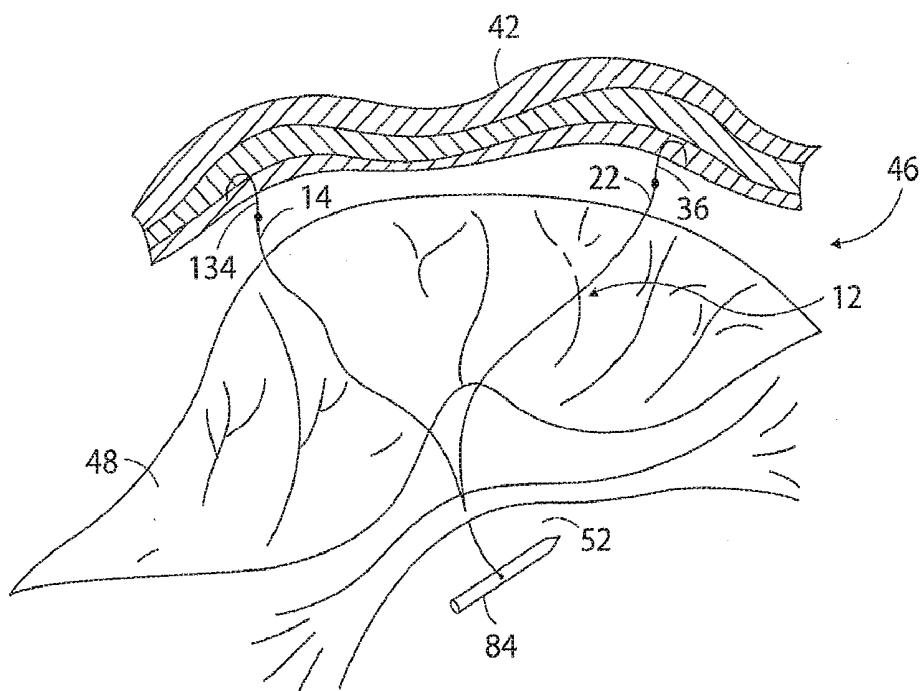


FIG. 15B

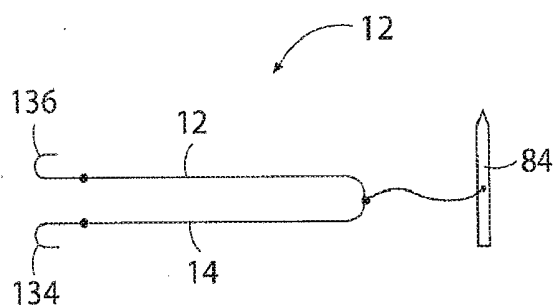


FIG. 15A

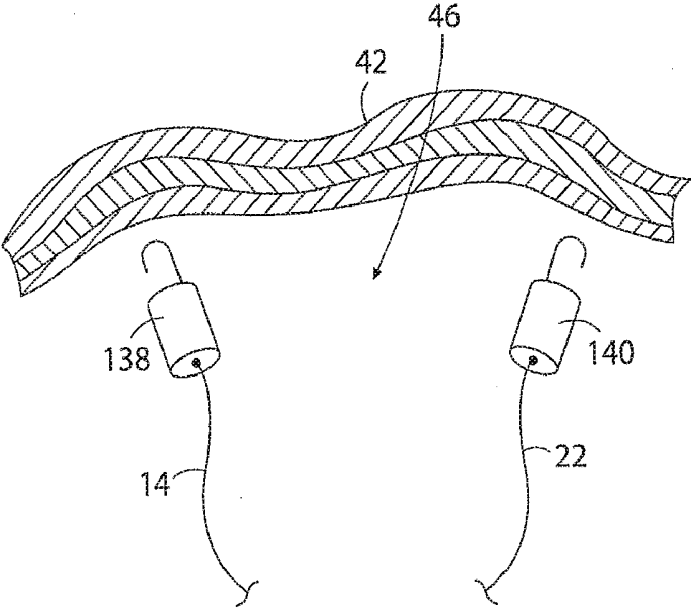


FIG. 16A

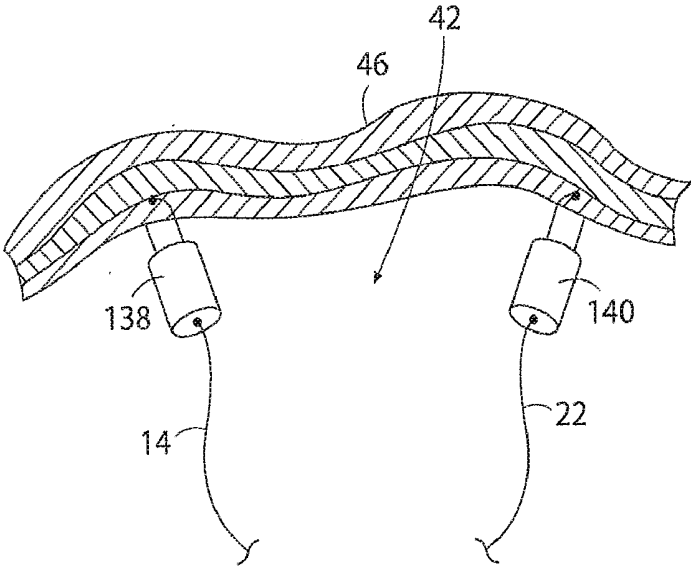


FIG. 16B

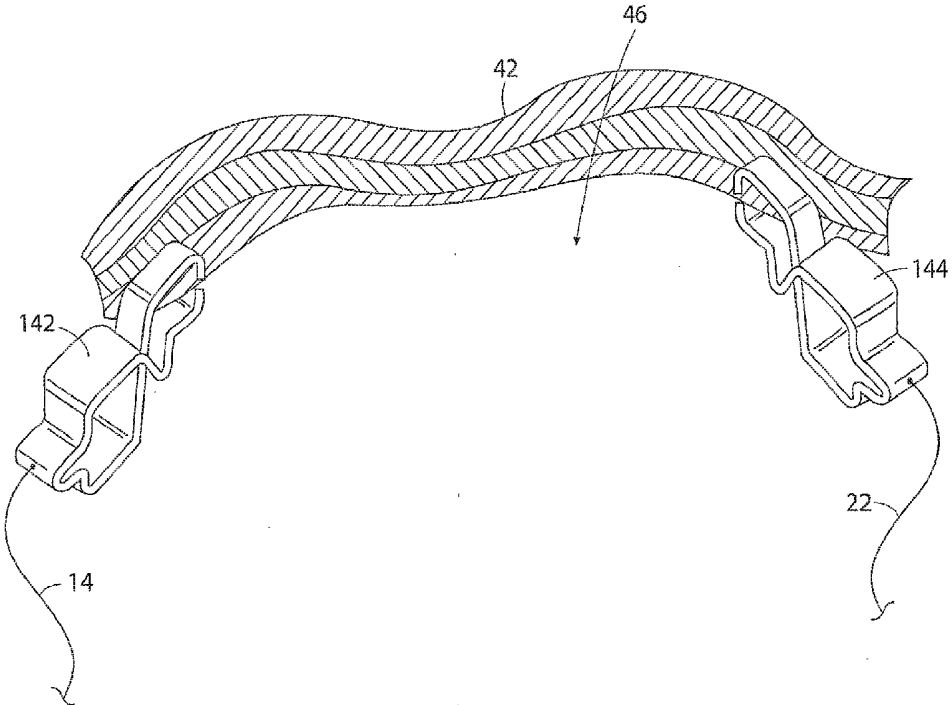


FIG. 17

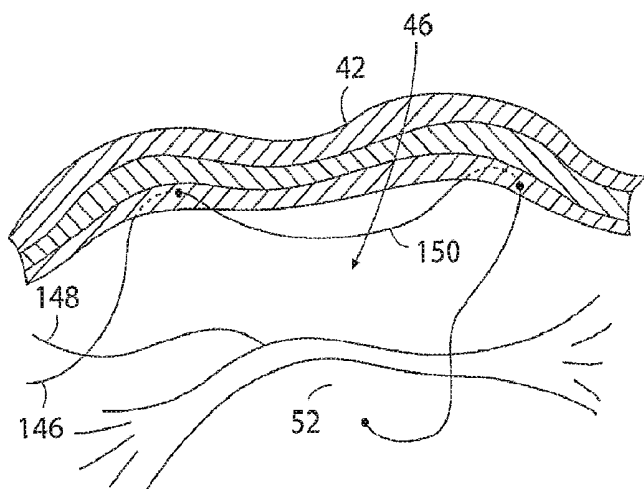


FIG. 18A

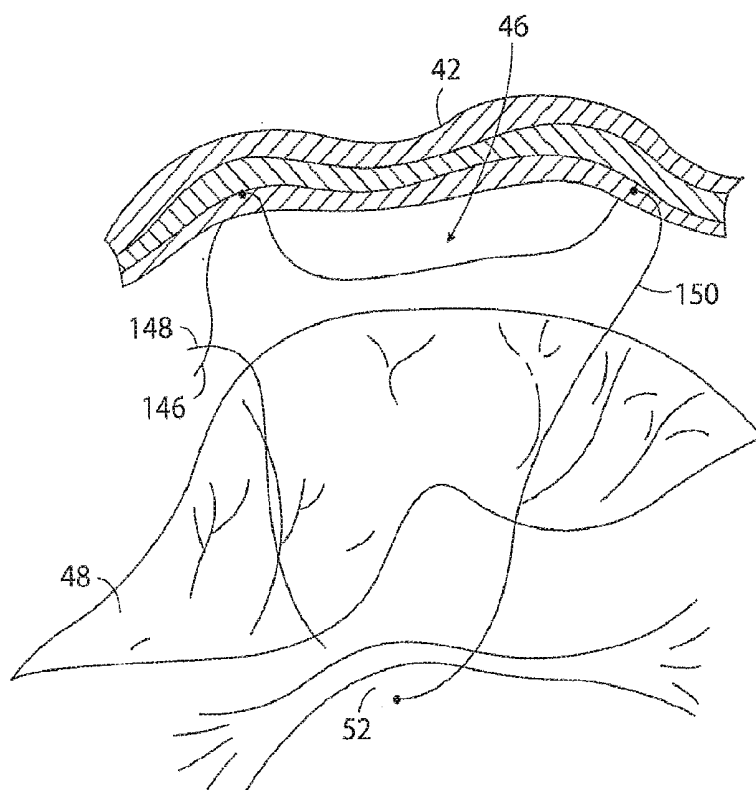


FIG. 18B

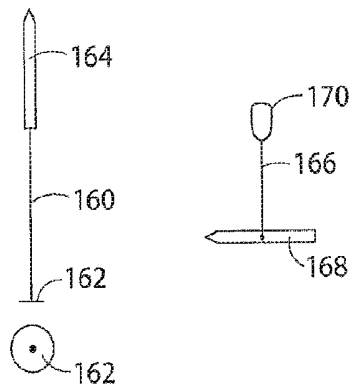


FIG. 20A

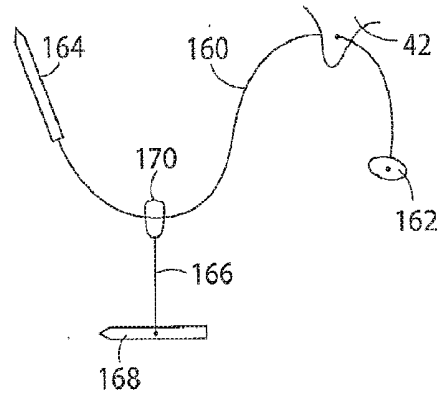


FIG. 20B

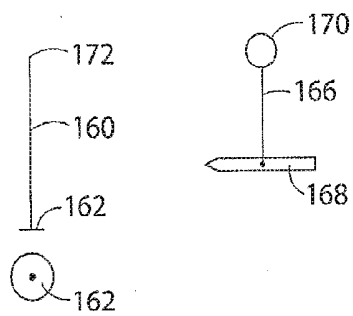


FIG. 21A

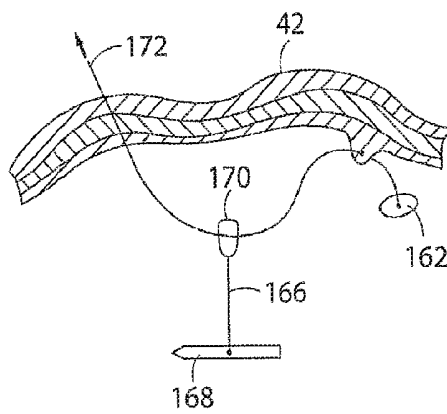


FIG. 21B



FIG. 22A

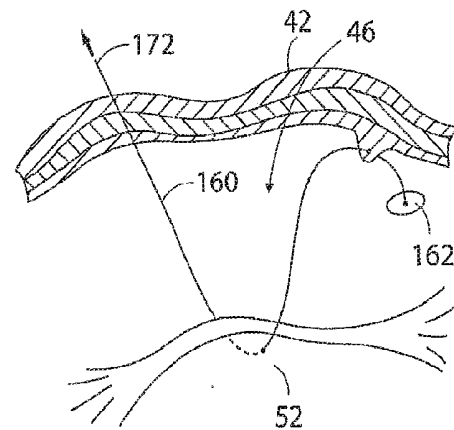


FIG. 22B

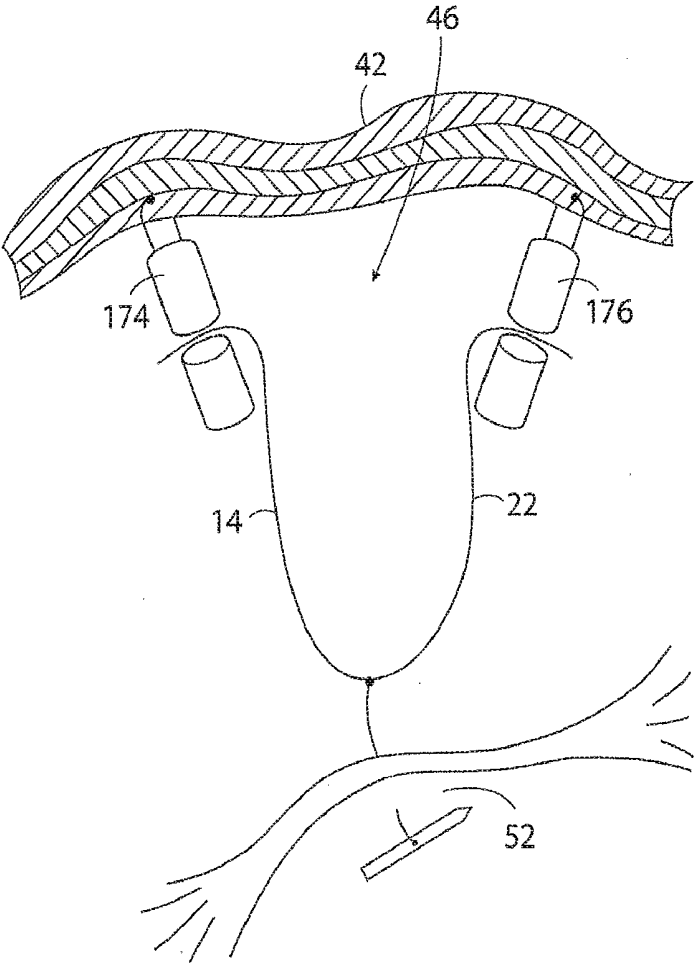


FIG. 23

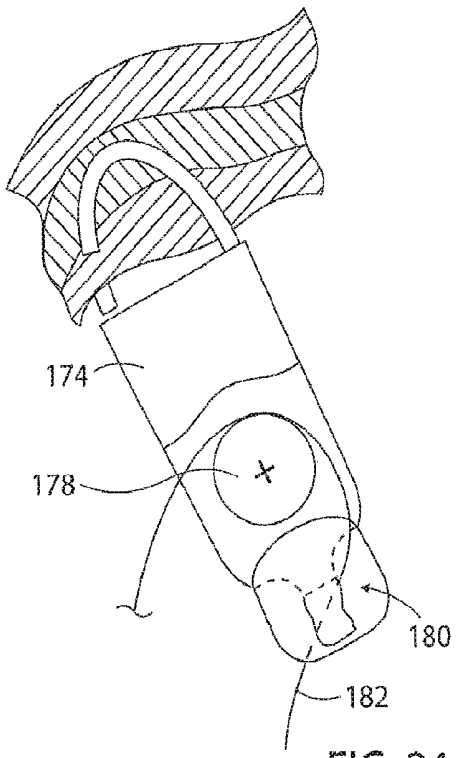


FIG. 24A

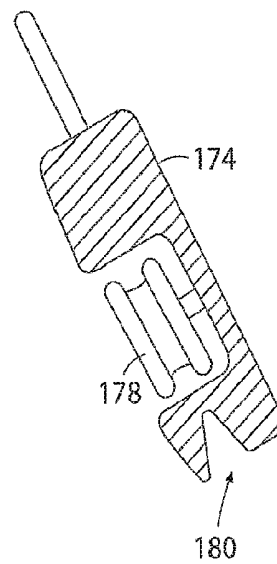


FIG. 24B

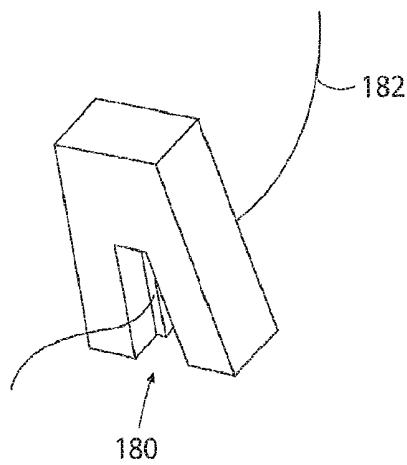


FIG. 24C

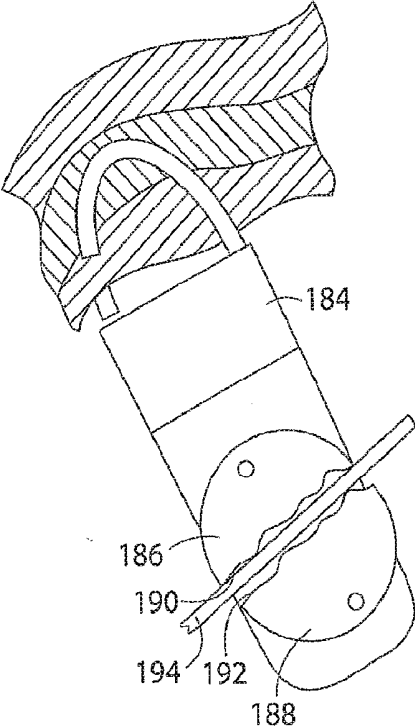


FIG. 25

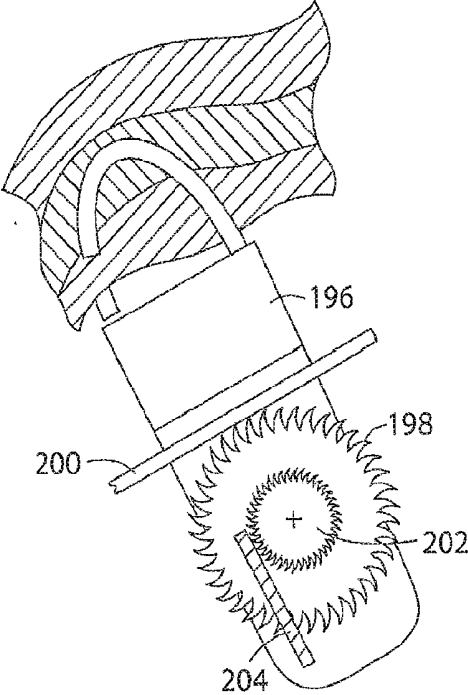


FIG. 26

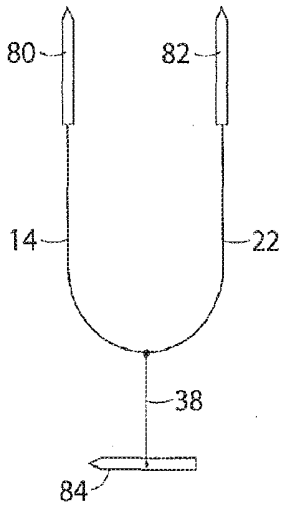


FIG. 27

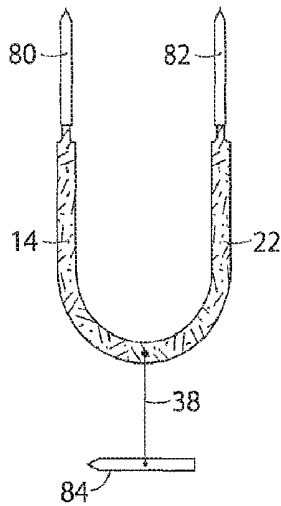


FIG. 28

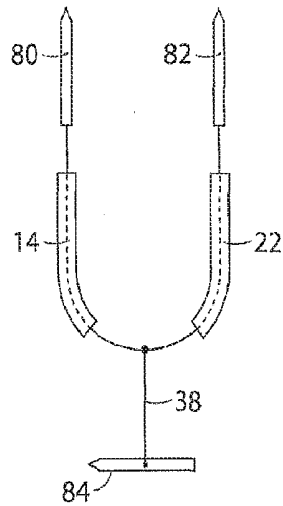


FIG. 29

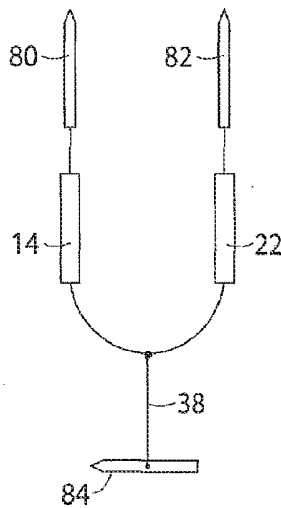


FIG. 30

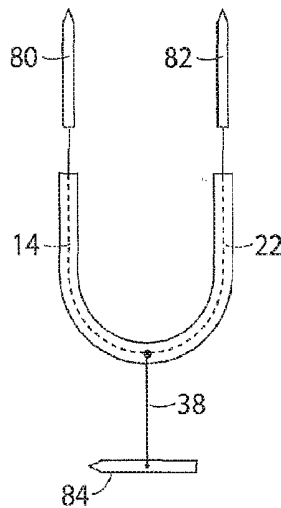


FIG. 31

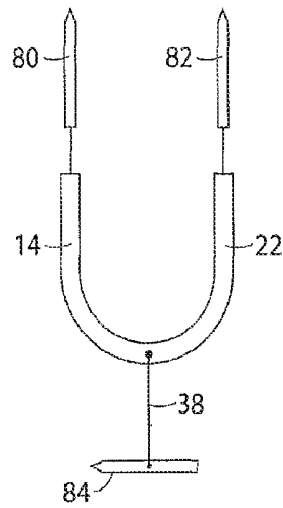


FIG. 32

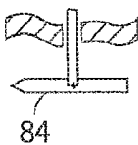


FIG. 33



FIG. 34

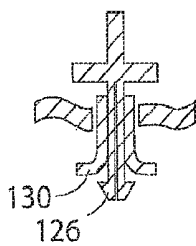


FIG. 35

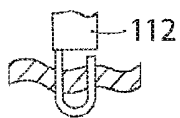


FIG. 36

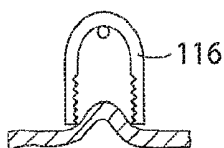


FIG. 37

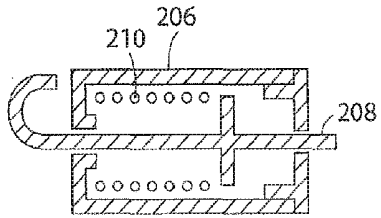


FIG. 38

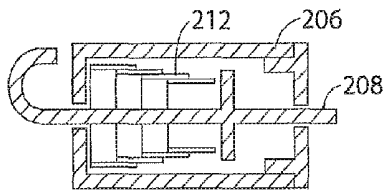


FIG. 39A

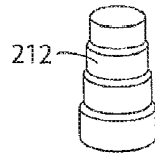


FIG. 39B

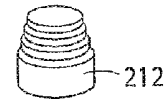


FIG. 39C

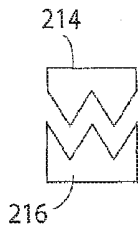


FIG. 40B

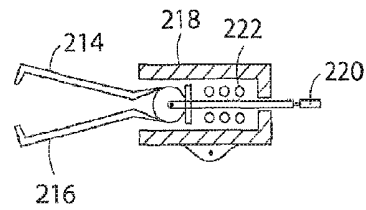


FIG. 40A

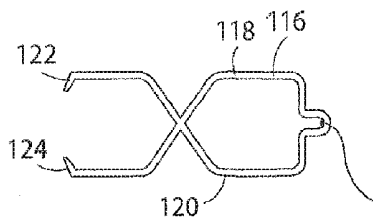


FIG. 41

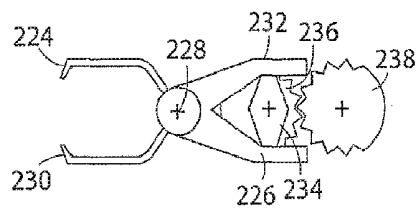


FIG. 42

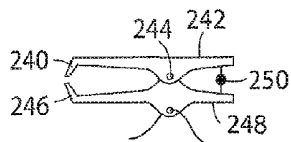


FIG. 43

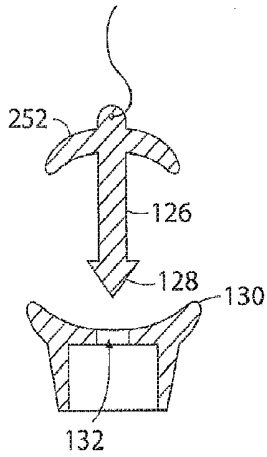


FIG. 44A

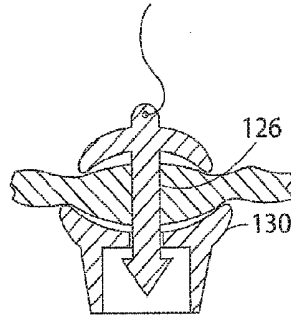


FIG. 44B

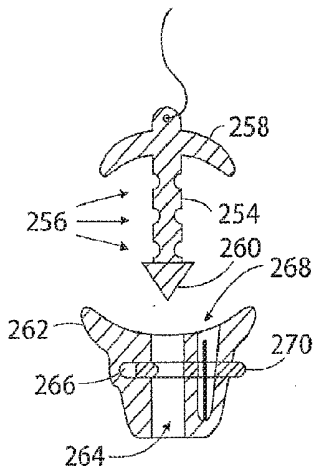


FIG. 45A

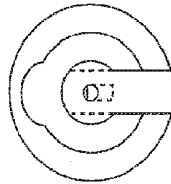


FIG. 45B

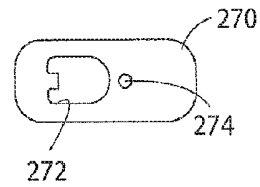


FIG. 45C

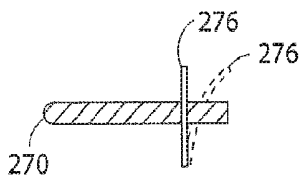


FIG. 45D

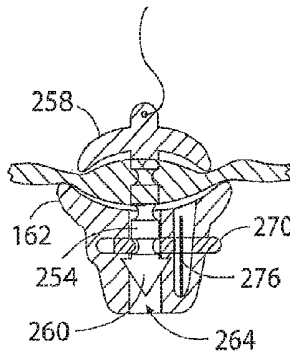


FIG. 45E

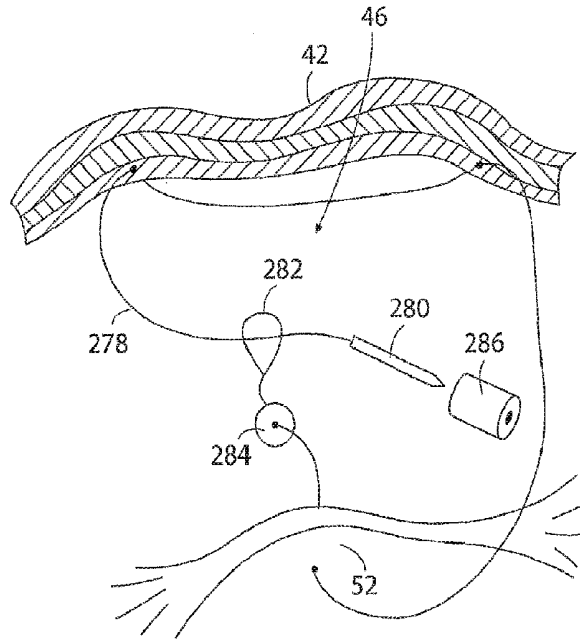
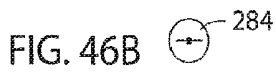
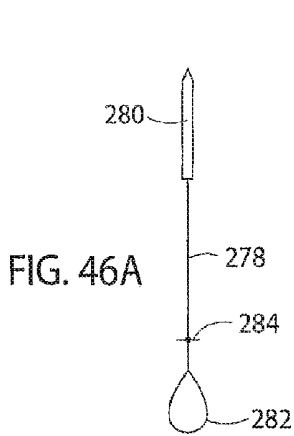


FIG. 46C

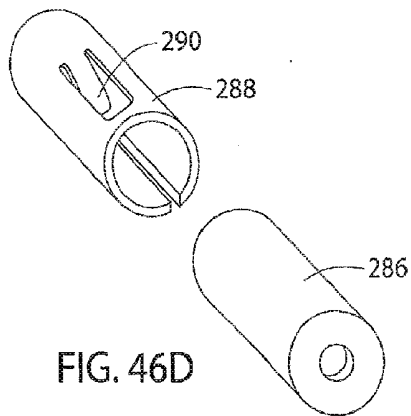


FIG. 46D

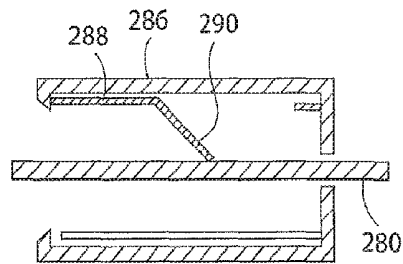


FIG. 46E

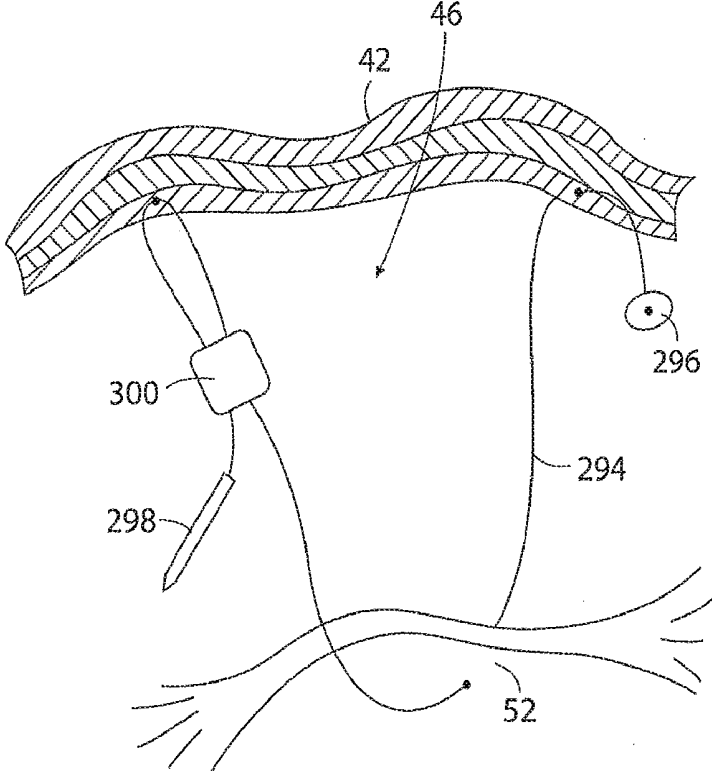


FIG. 47A

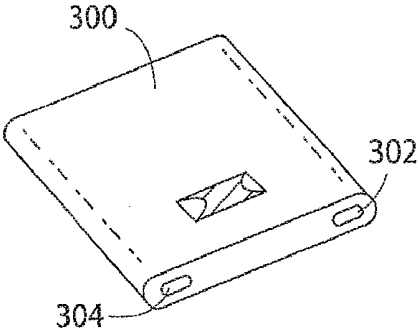


FIG. 47B

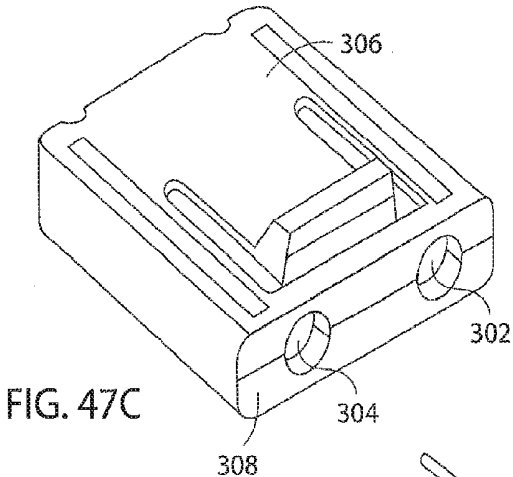


FIG. 47C

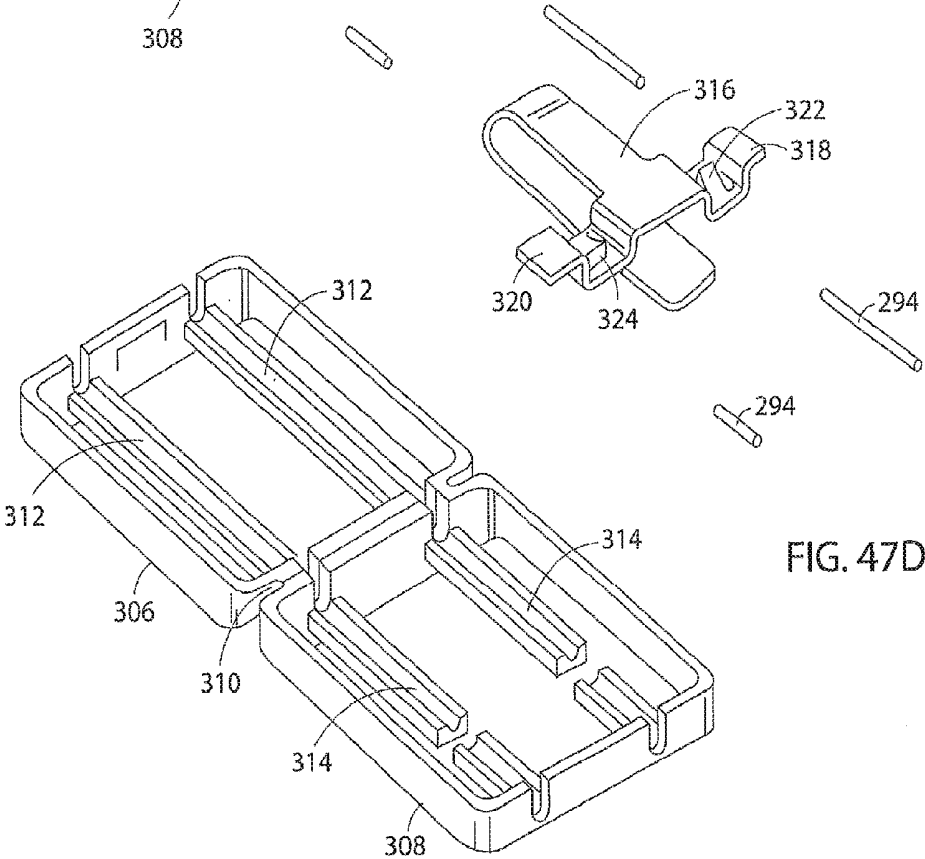


FIG. 47D

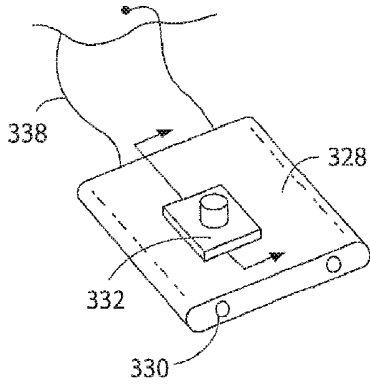


FIG. 48A

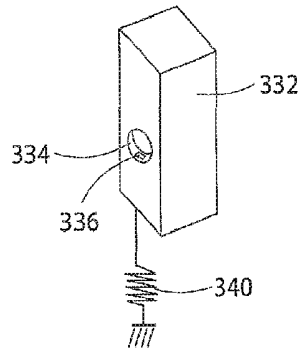


FIG. 48B

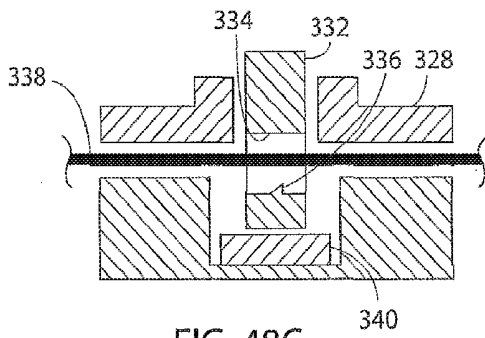


FIG. 48C

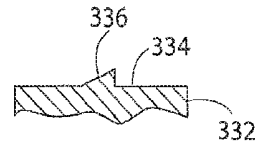


FIG. 48D

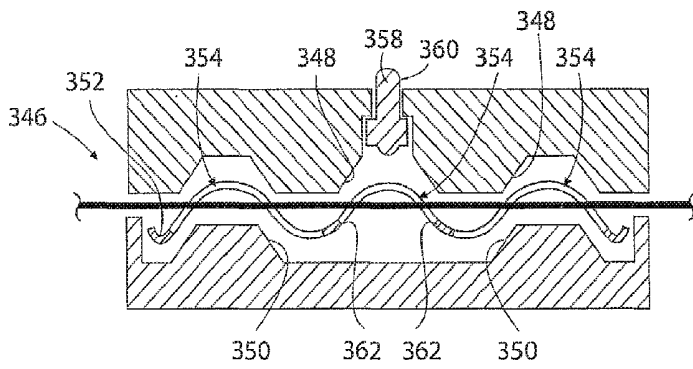


FIG. 49A

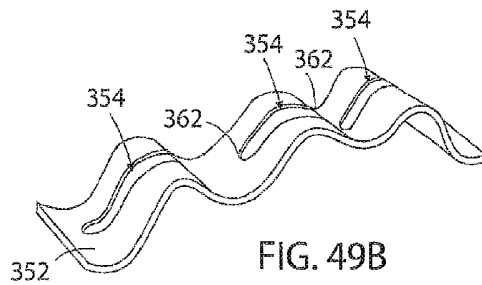
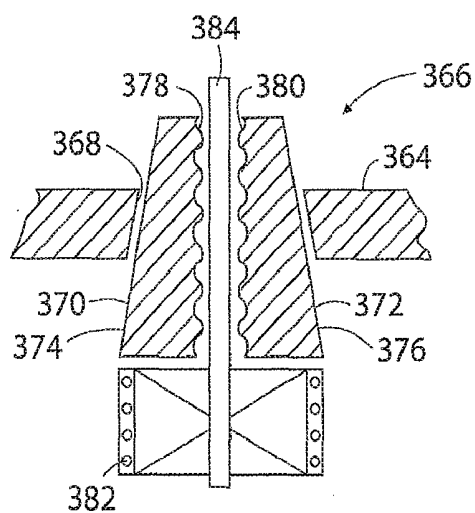
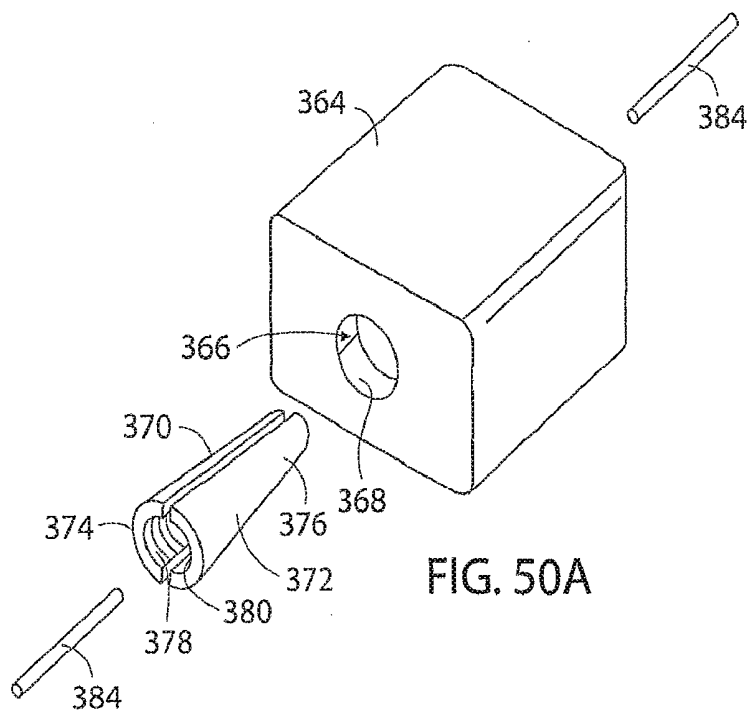


FIG. 49B



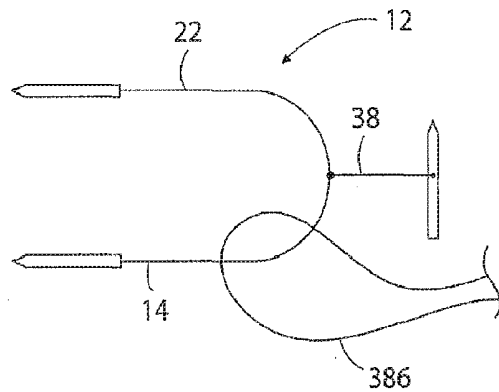


FIG. 51A

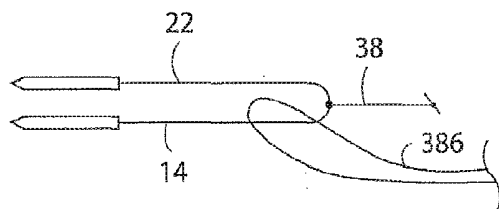


FIG. 51B

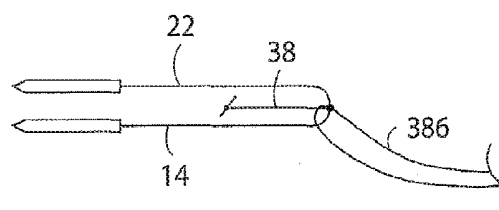


FIG. 51C

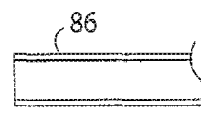
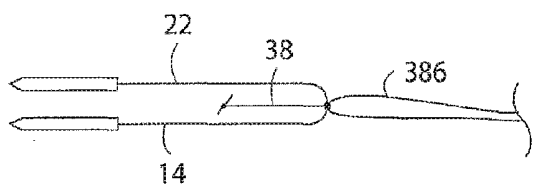


FIG. 51D

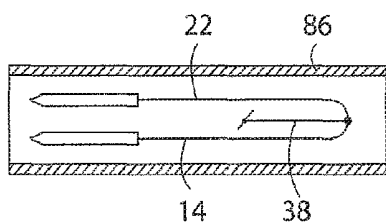


FIG. 51E

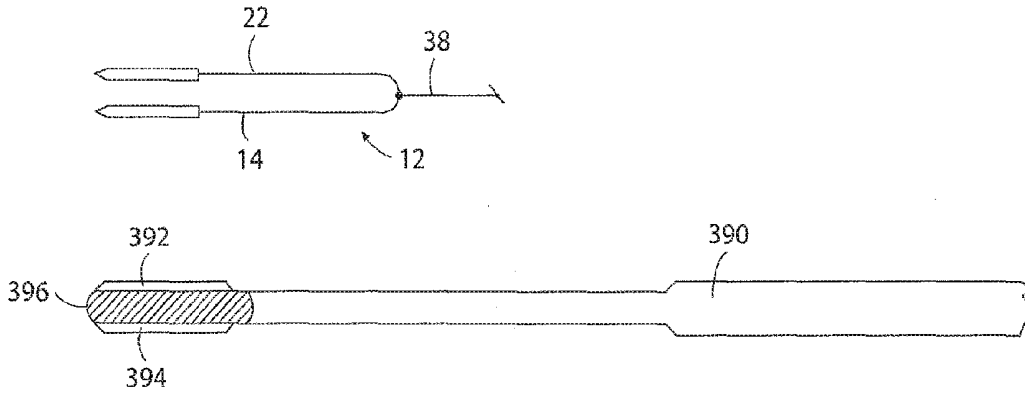


FIG. 52A

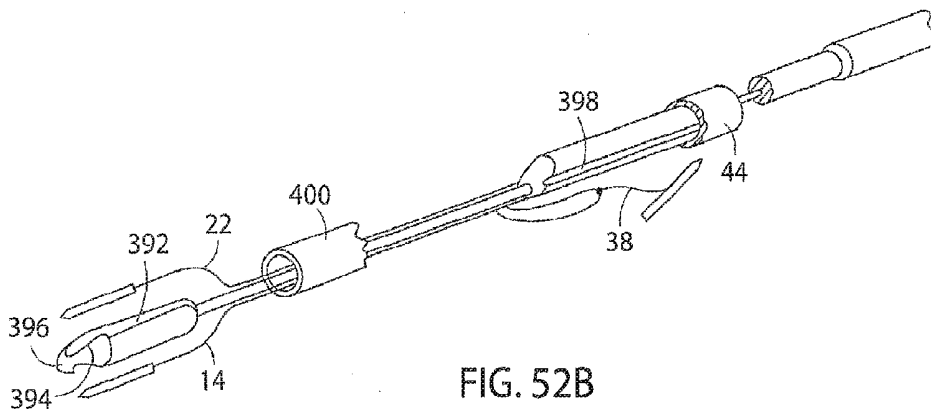


FIG. 52B

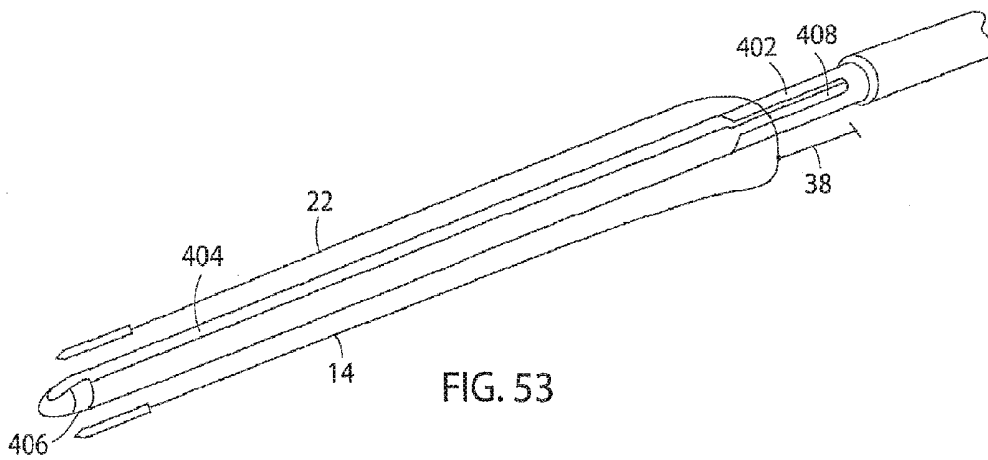


FIG. 53

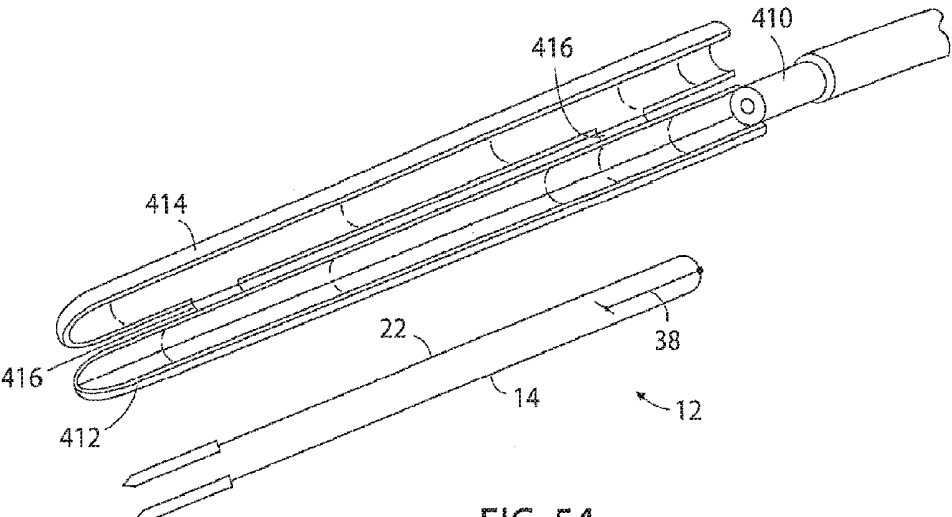


FIG. 54

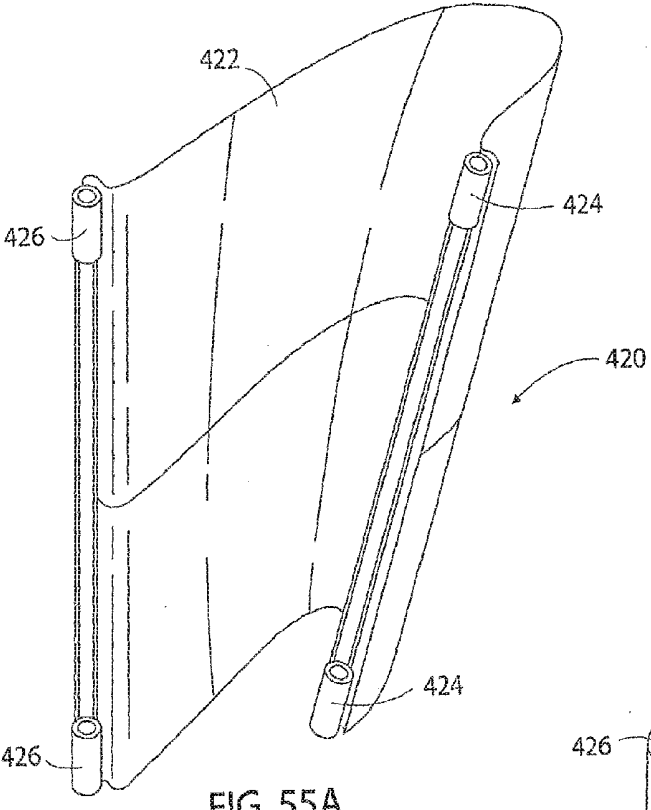


FIG. 55A

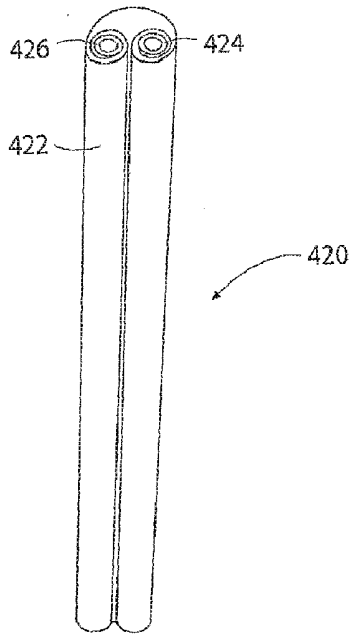
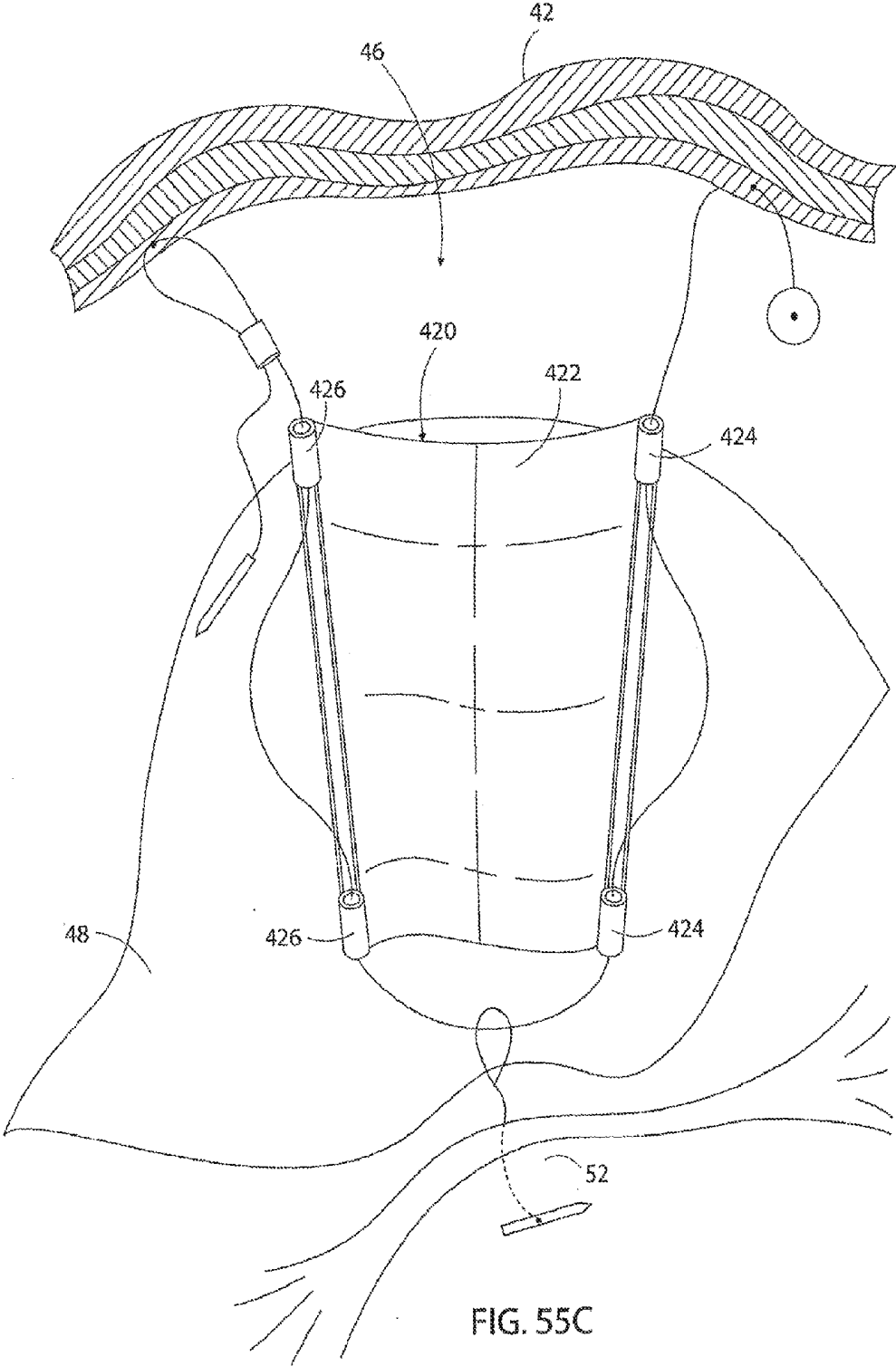


FIG. 55B



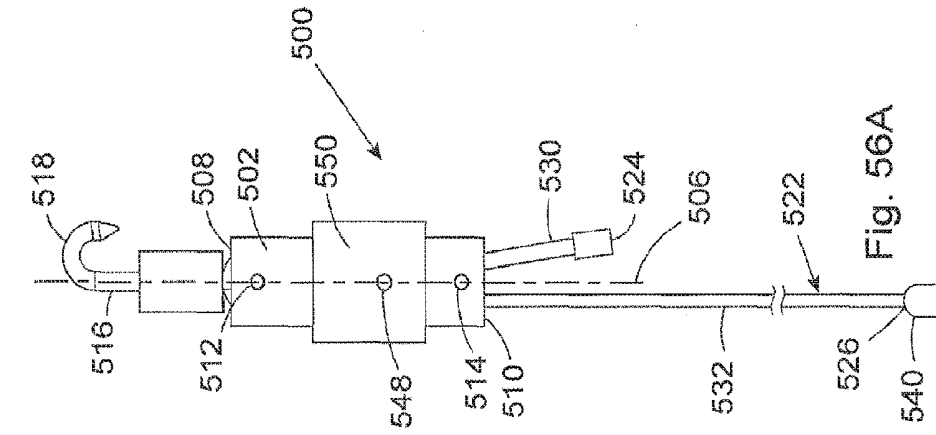


Fig. 56A

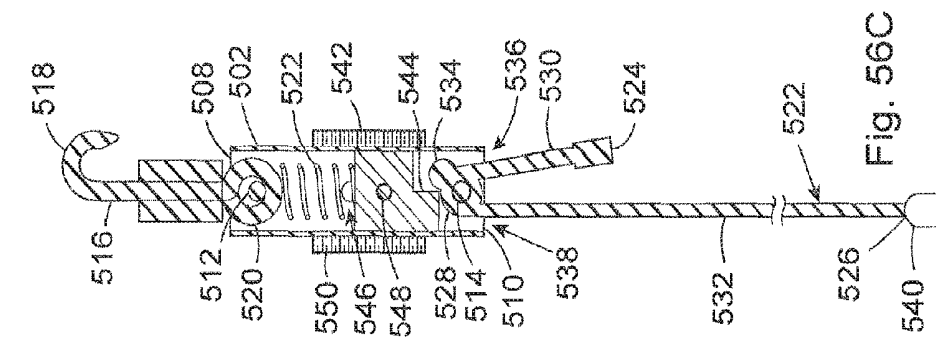


Fig. 56C

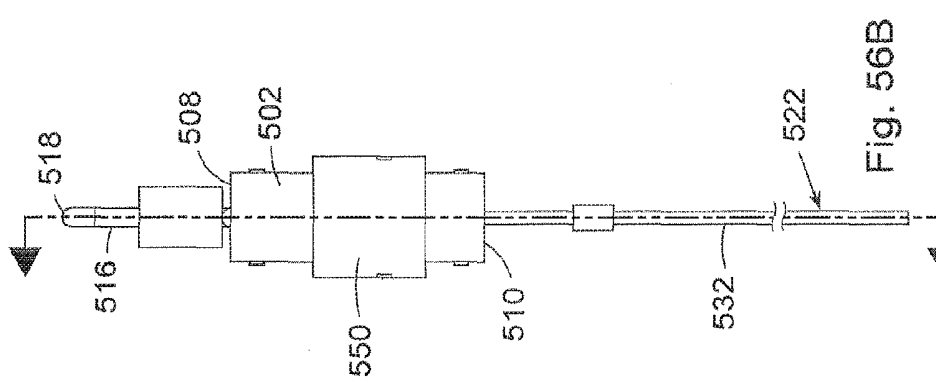
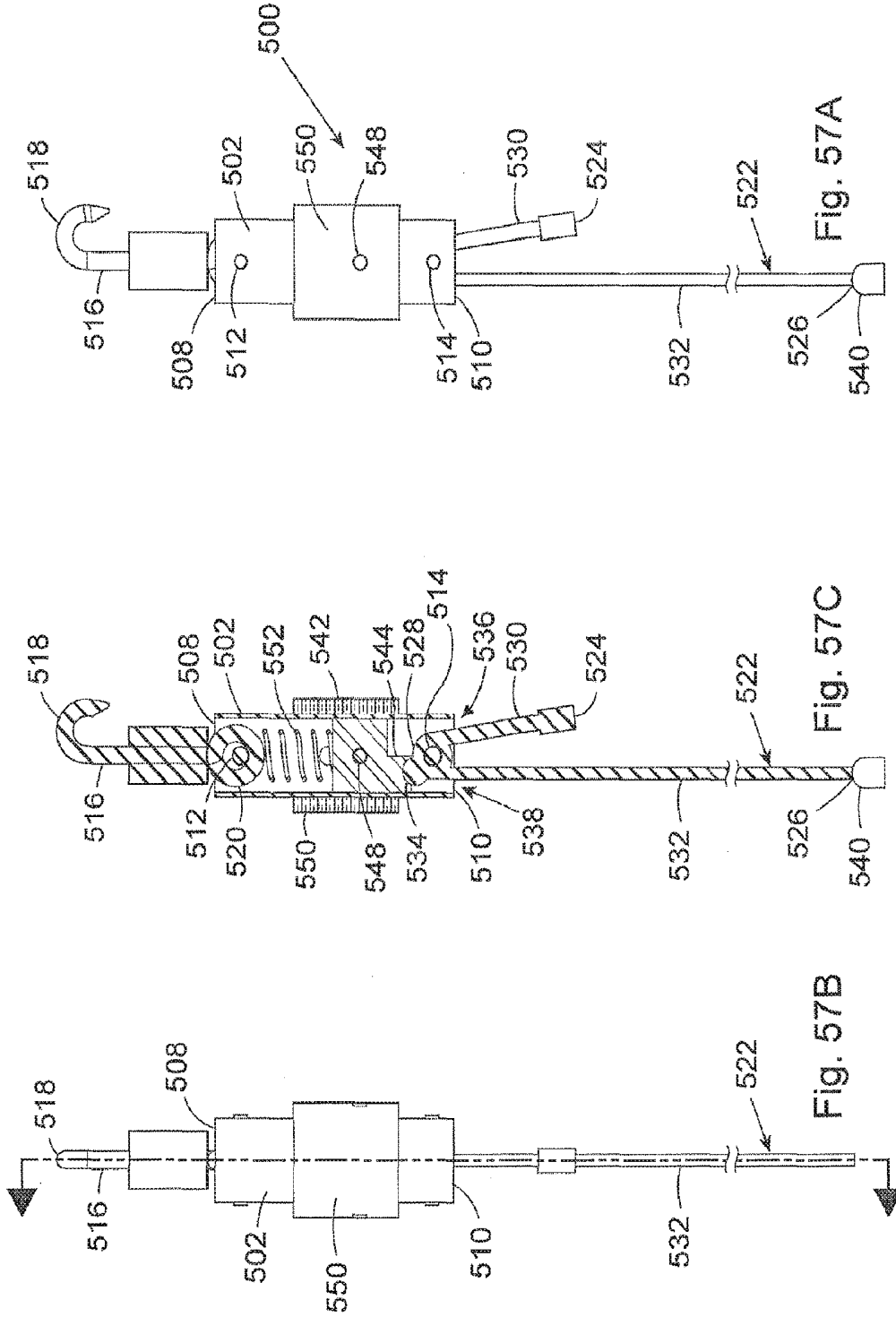
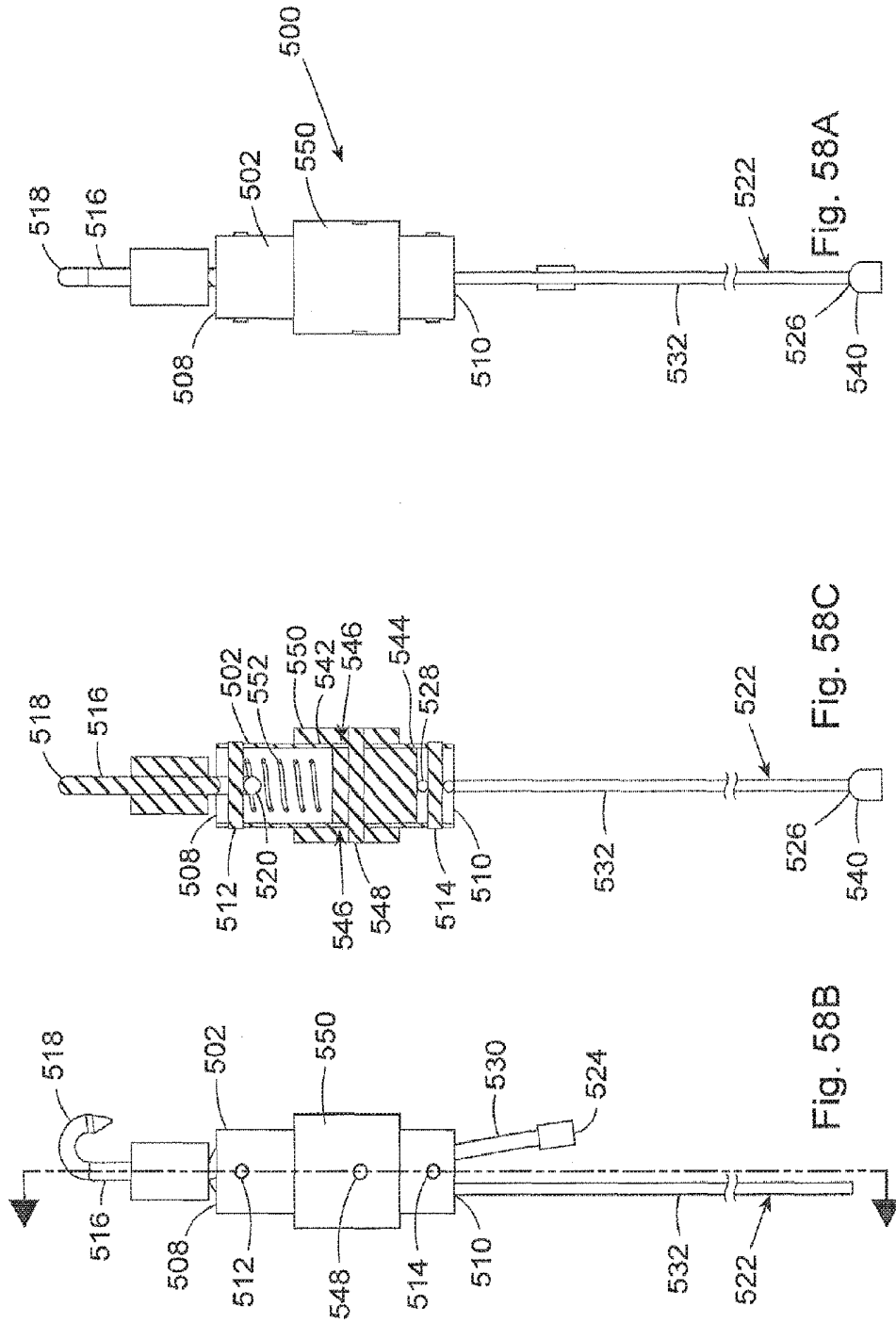
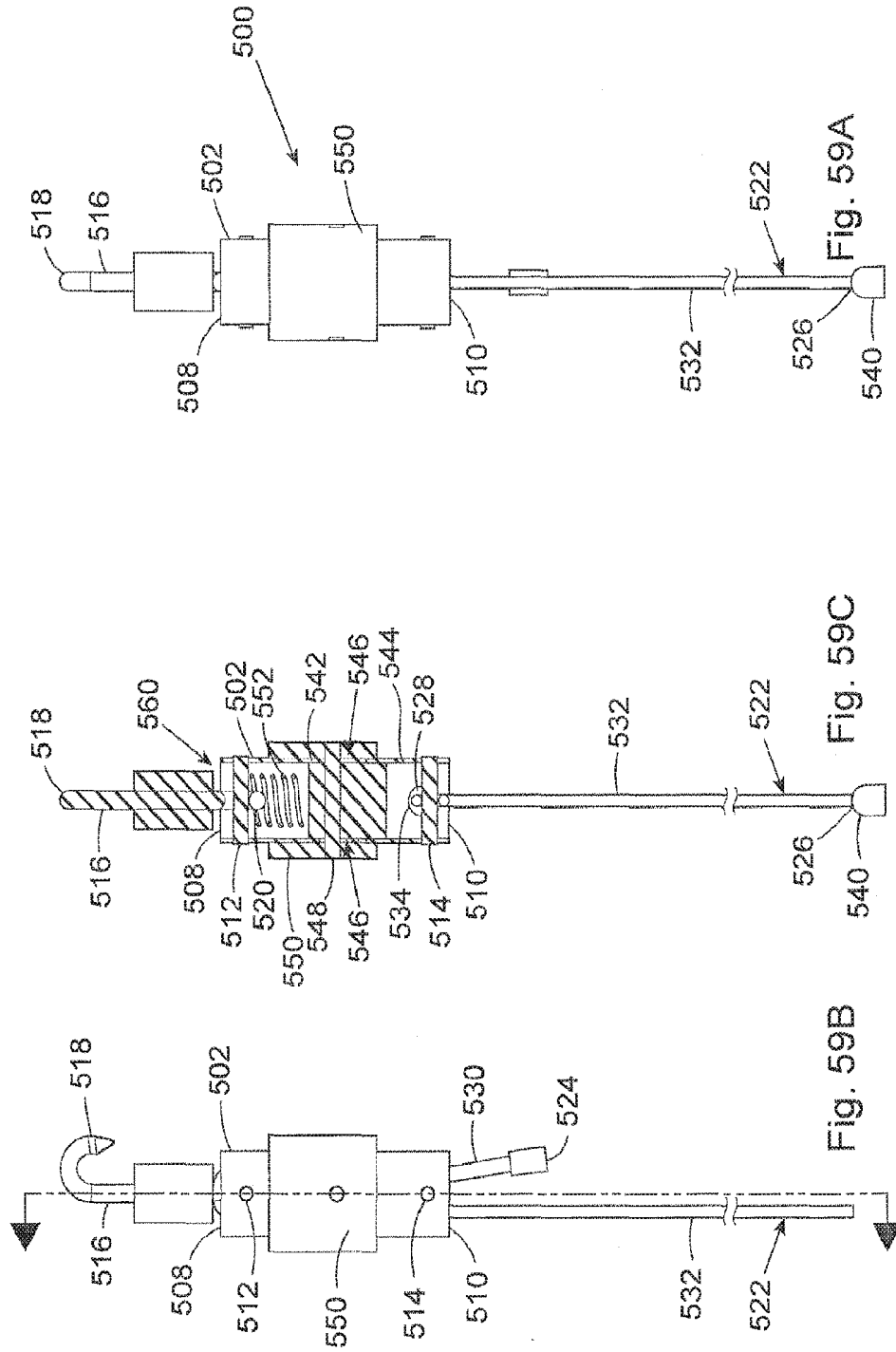
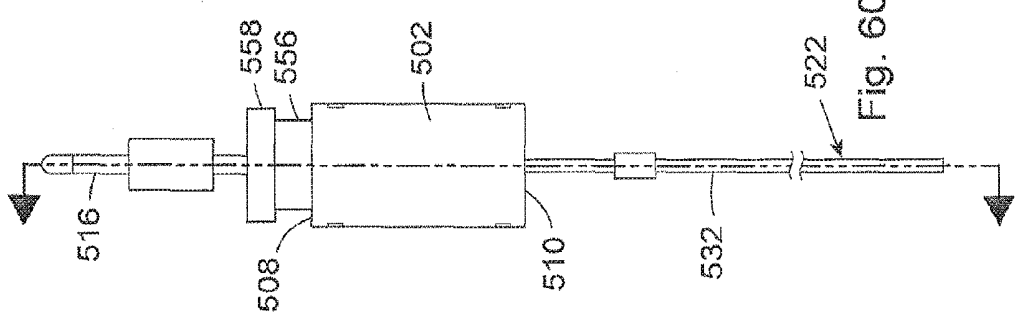
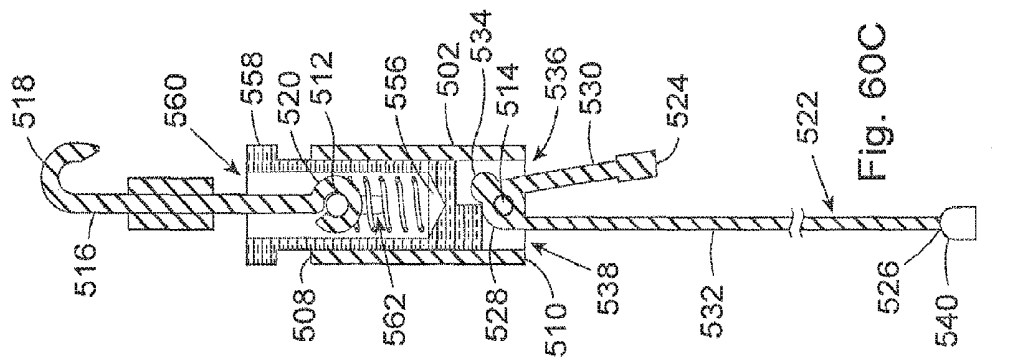
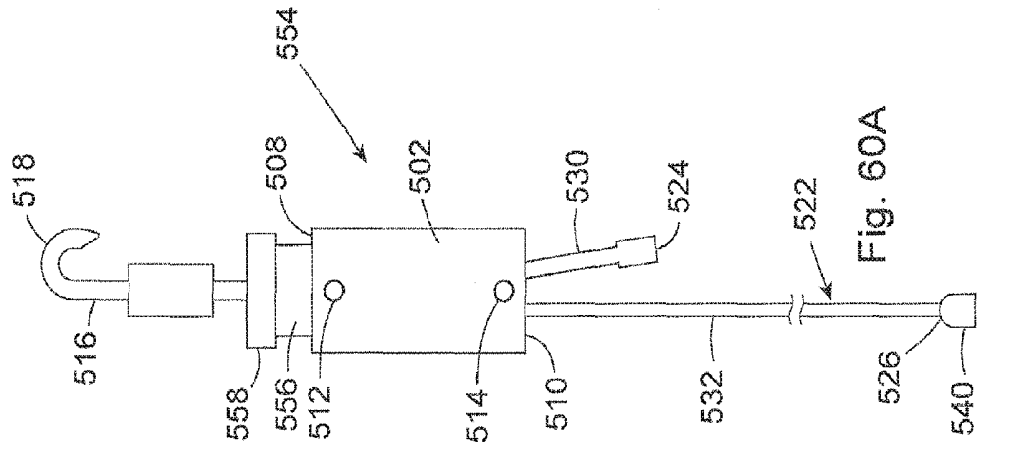


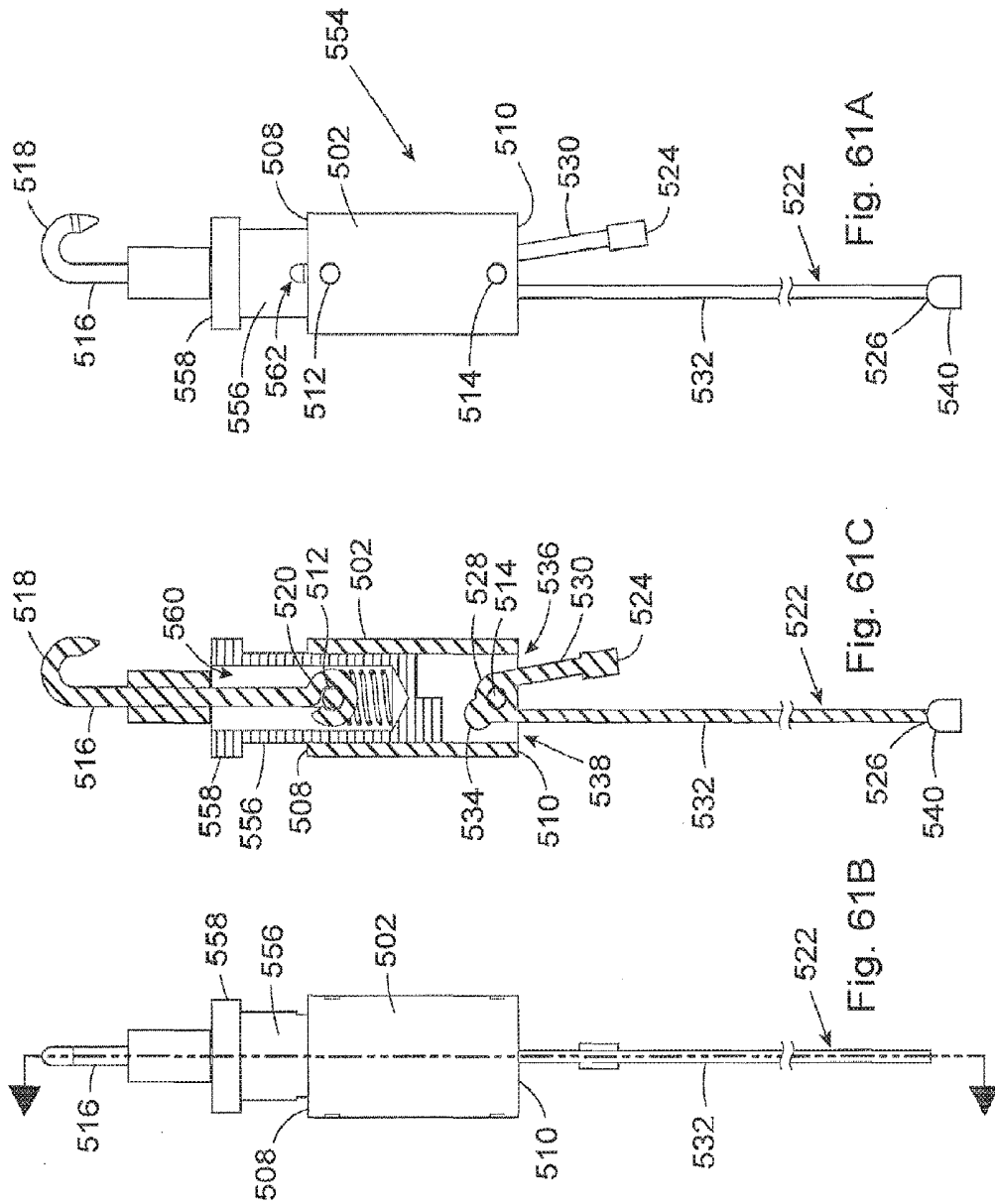
Fig. 56B

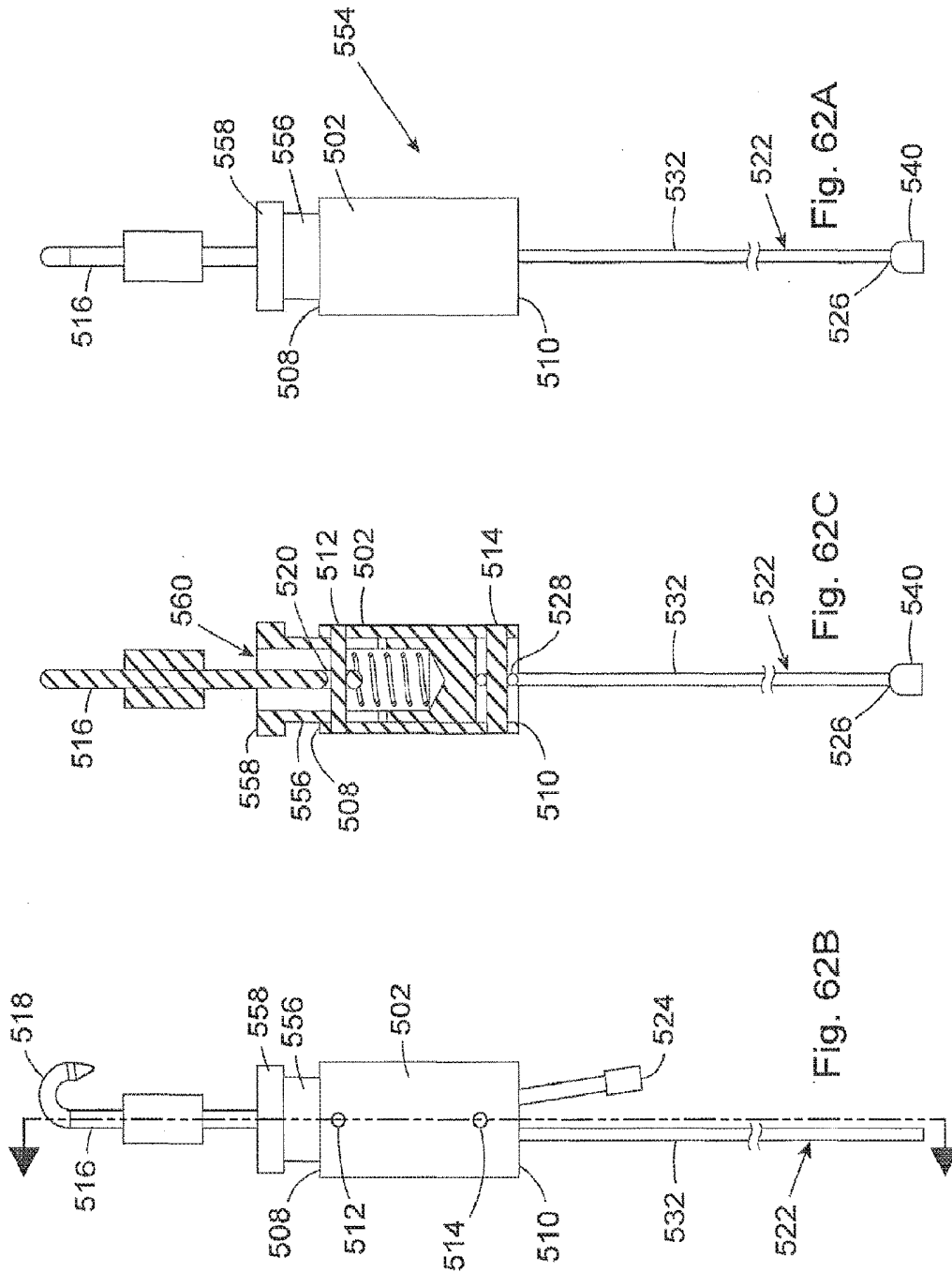


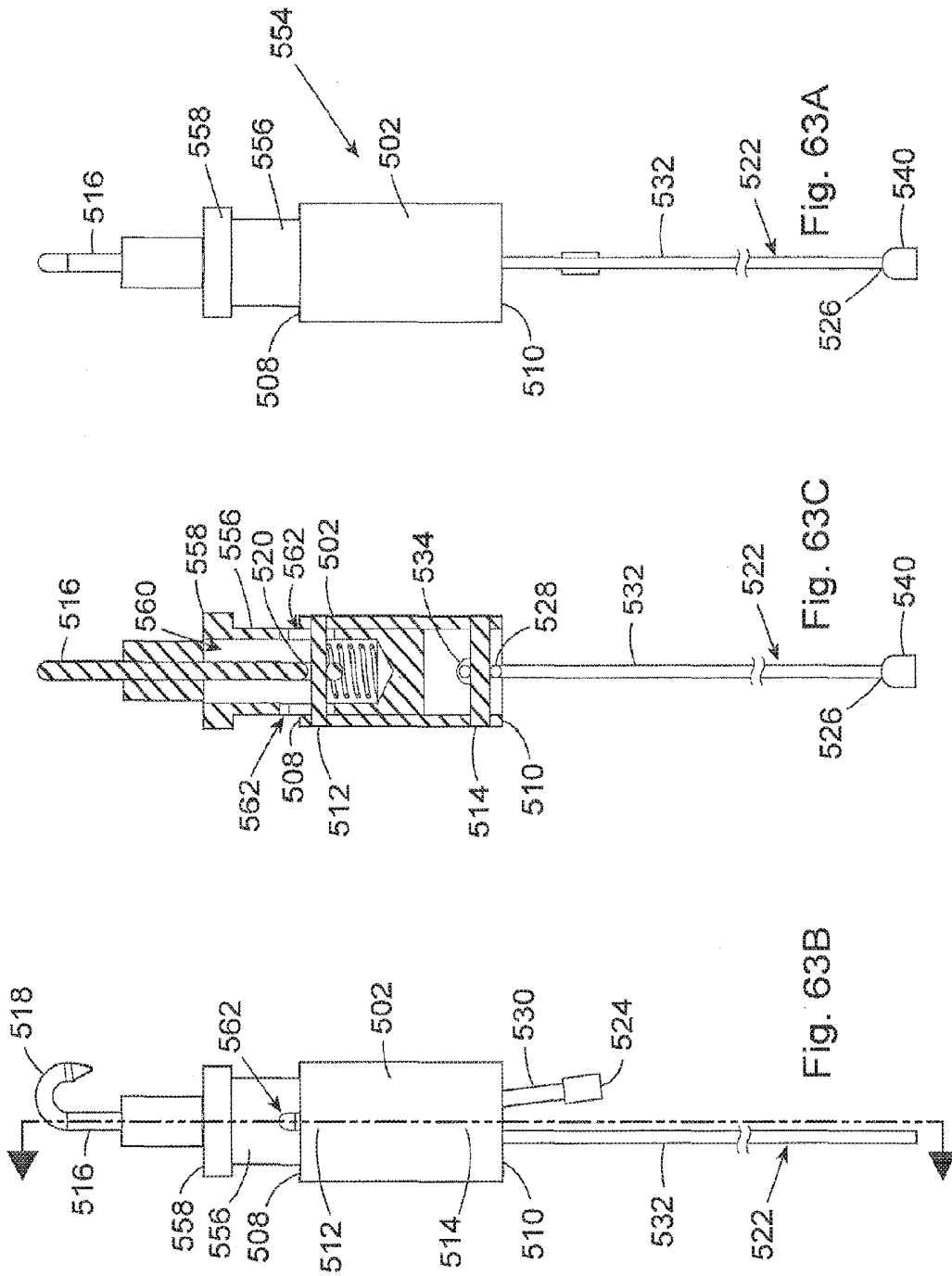












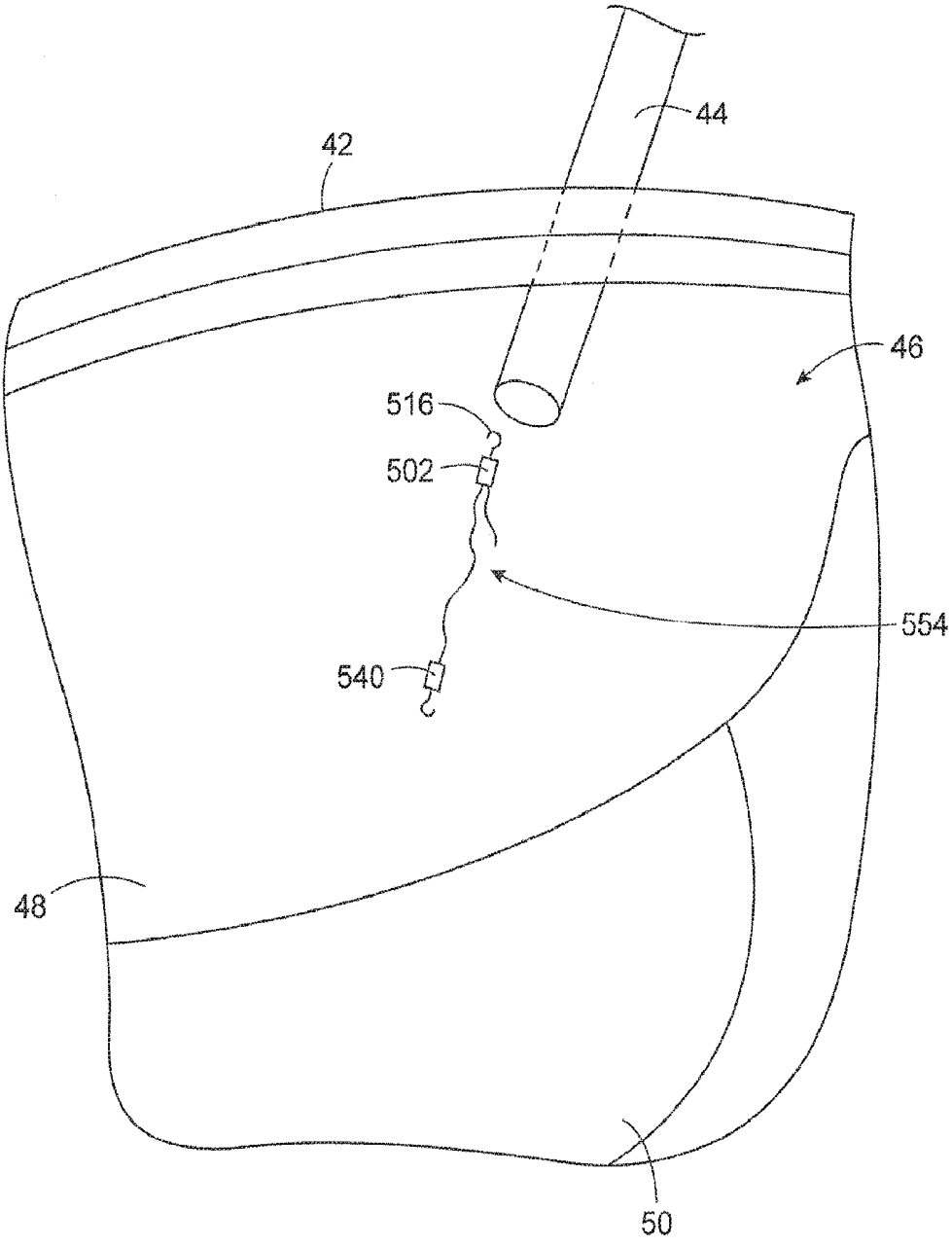


Fig. 64

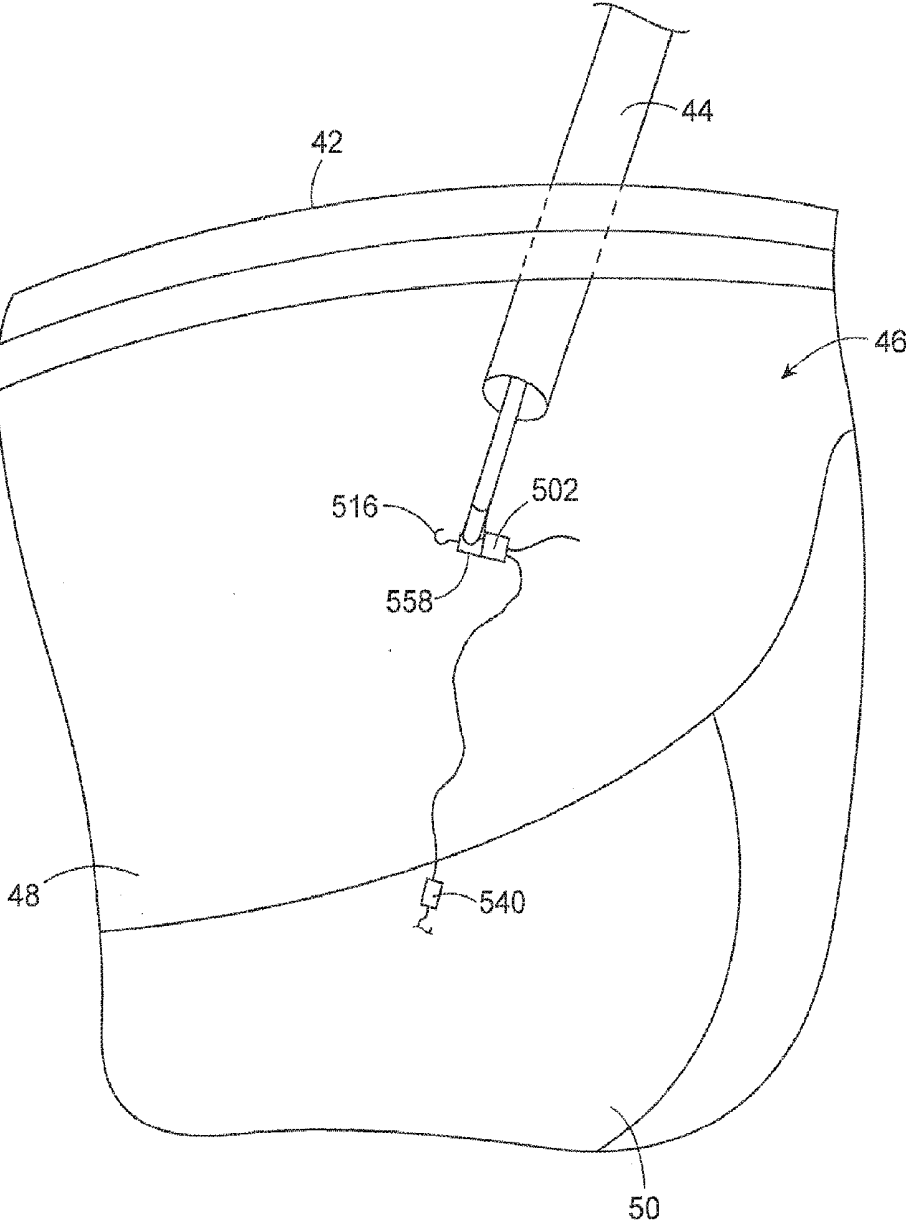


Fig. 65

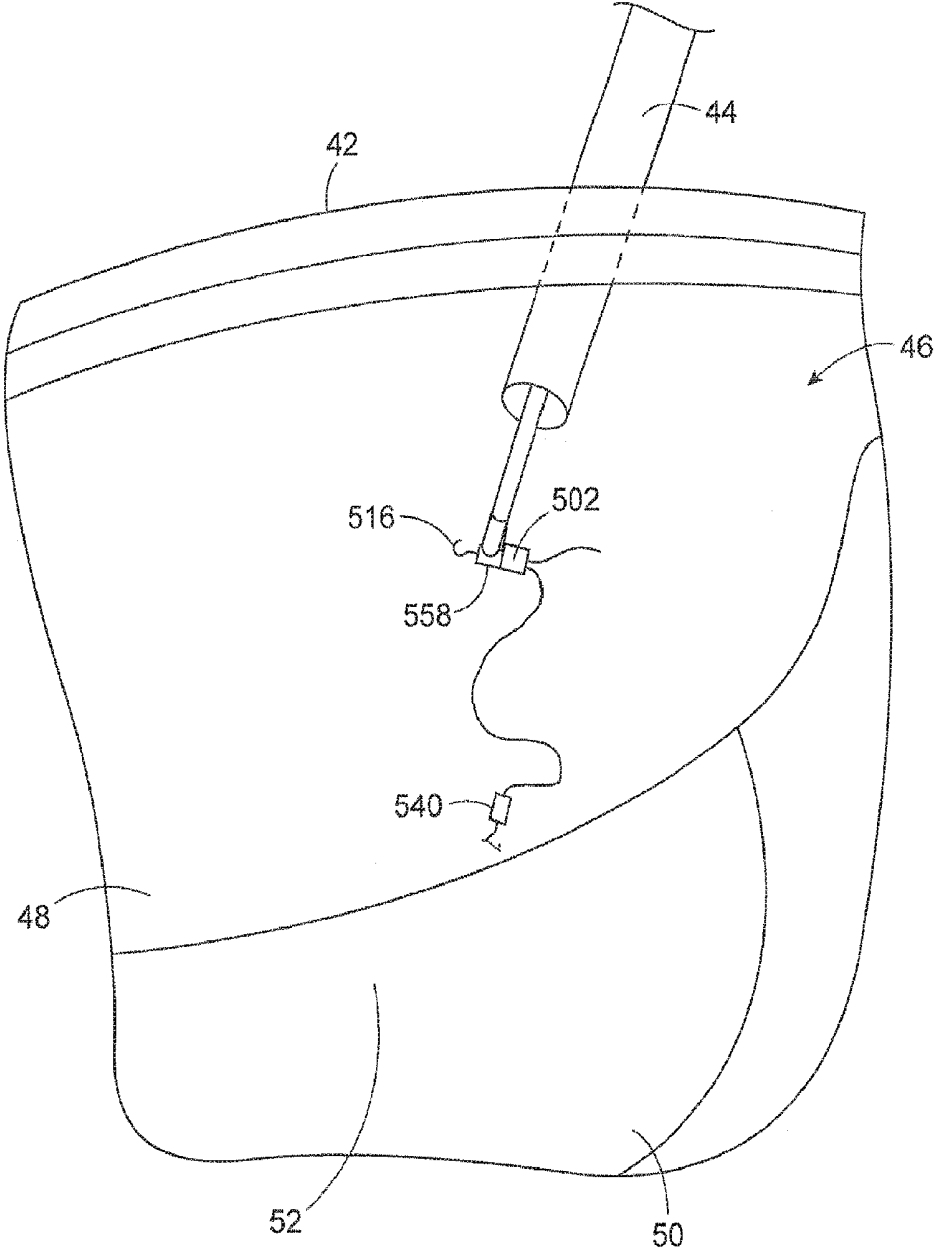


Fig. 66

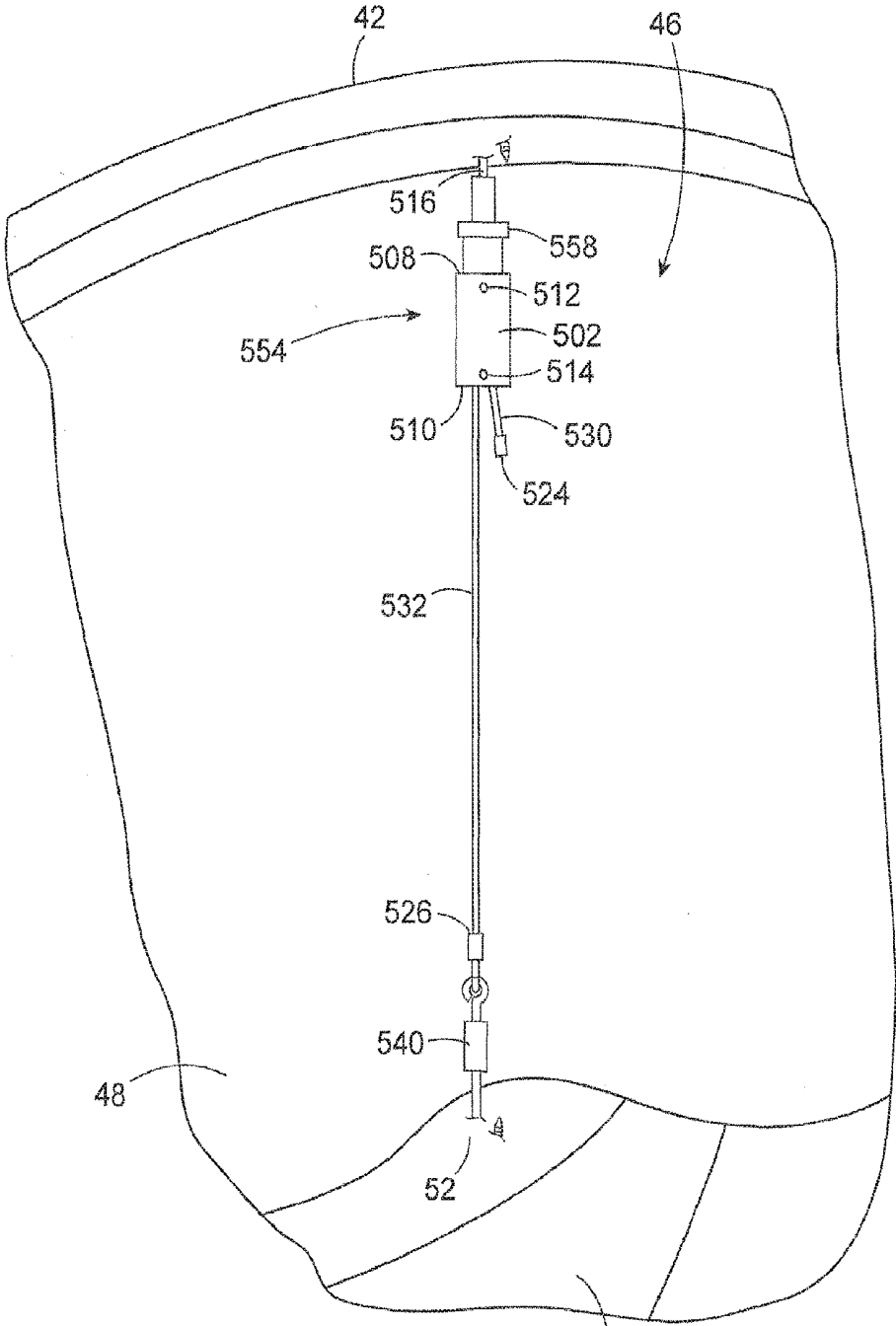


Fig. 67

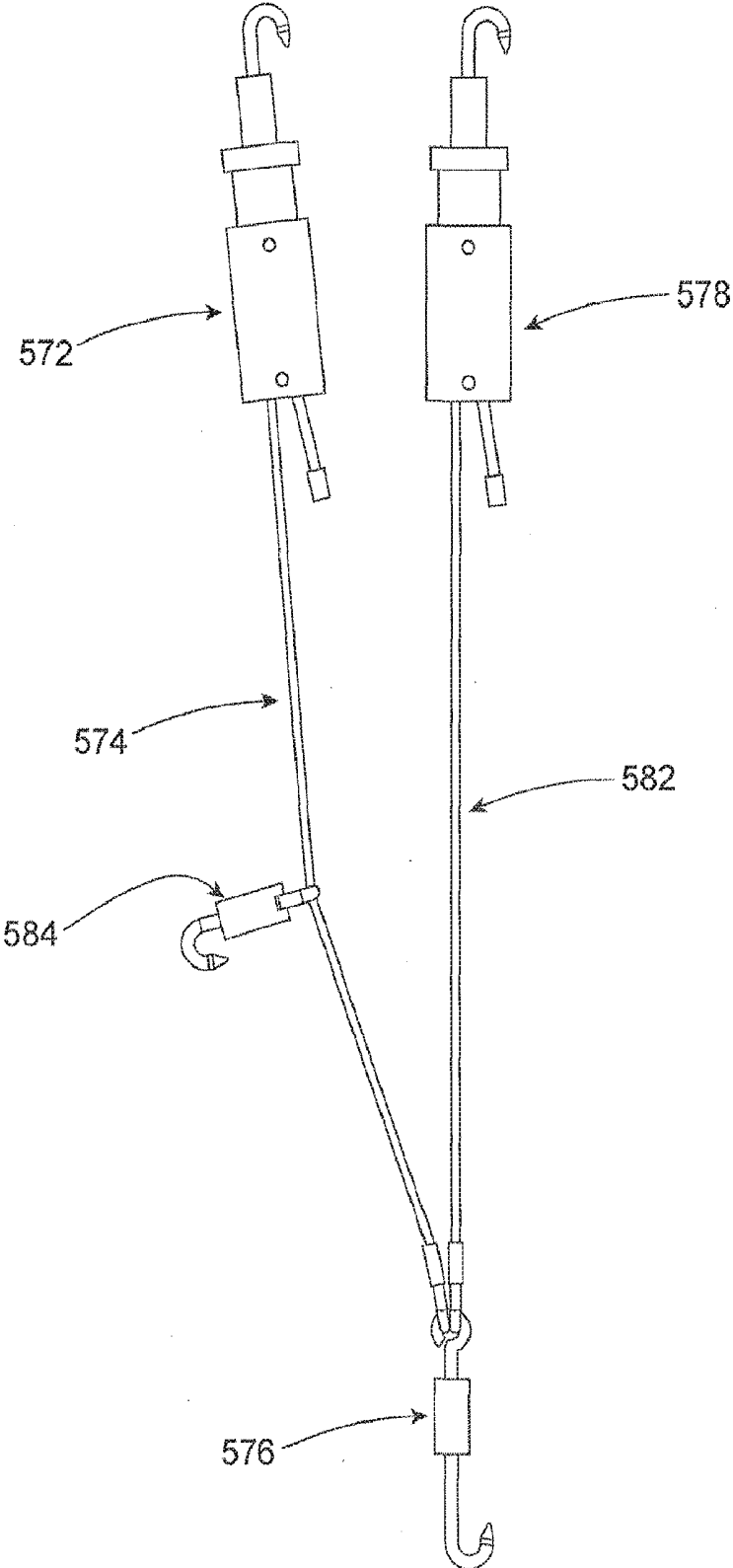


Fig. 68

SYSTEM FOR INTRA-ABDOMINALLY MOVING AN ORGAN

[0001] This application is a continuation of U.S. application Ser. No. 14/240,928, filed Feb. 25, 2014, which is a national stage of PCT Application PCT/US2011/001494 filed Aug. 25, 2011.

BACKGROUND OF THE INVENTION

[0002] 1. Field of the Invention

[0003] The present invention is directed to an apparatus and its method of use in intra-abdominally moving a first internal organ to a position away from a second internal organ where the apparatus holds the first internal organ in the position without further manual input. More specifically, the present invention is directed to an apparatus that is inserted through the abdominal wall and into the abdominal cavity, and the method of using the apparatus in the abdominal cavity to move a human liver to a position away from a human stomach where the apparatus holds the liver in the position without further manual input, thereby providing surgical access to the stomach.

[0004] 2. Description of the Related Art

[0005] In laparoscopic surgical procedures, it is often necessary to make incisions through the abdominal wall for the sole purpose of providing access to the abdominal cavity for surgical graspers or other similar types of retracting instruments that are used to move one internal organ to a position away from a second internal organ to gain surgical access to the second internal organ. The incisions made for the surgical graspers or similar retracting instruments are in addition to the incisions made in the abdominal wall for the surgical instruments used in performing the surgical procedure on the second organ.

[0006] Furthermore, it is often necessary that an additional surgeon or surgical assistant be present solely for the purpose of manipulating the surgical graspers or other similar retracting instruments in moving the first internal organ to a position away from the second internal organ, and then manually holding the first internal organ in the position during the surgical procedure performed on the second internal organ.

[0007] The need for the additional surgical personnel to manipulate and hold the surgical graspers or other similar retracting instruments during the surgical procedure increases the costs of surgery. In addition, the additional incisions in the abdominal wall required for the surgical graspers or other similar retracting instruments often results in additional discomfort to the patient following surgery and additional scarring.

[0008] What is needed to overcome these disadvantages associated with the above-described type of laparoscopic surgical procedure is an apparatus that can be operated to intra-abdominally move a first internal organ to a position away from a second internal organ and then hold the first internal organ in the position without requiring additional manual input other than that provided by the surgeon and without requiring additional abdominal incisions other than those required for the surgery.

SUMMARY OF THE INVENTION

[0009] The present invention overcomes the above-described shortcomings of laparoscopic surgical procedures by providing an apparatus that can be inserted into the abdomi-

nal cavity through the same incision to be used in a laparoscopic surgery procedure, and the method of using the apparatus to move or retract a first internal organ, for example the liver, away from a second internal organ, for example the stomach, and then hold the first internal organ in the retracted position providing surgical access to the second internal organ without requiring further manual input.

[0010] The apparatus is constructed of component parts that are often used in laparoscopic as well as other types of surgical procedures. The component parts will be described herein using their common understood names and their functions, without going into details of the particular constructions of the component parts.

[0011] The basic construction of the apparatus of the invention includes a length of cord. The cord could be comprised of a first cord segment having a flexible length with opposite first and second ends, and a second cord segment having a flexible length with opposite first and second ends. The cord segments could be provided by lengths of suture, lengths of tubing such as IV tubing, lengths of umbilical tape or elastic strips, or other equivalent cord constructions. The first and second cord segments could be separate cord segments that are attached together, or could be two cord segments of a single continuous length of cord.

[0012] In one embodiment of the apparatus, first, second, and third separate tissue connectors are attached to the first and second cord segments. The tissue connectors can be any type of known tissue connector that can be manually manipulated to connect to body tissue, and then manually manipulated to be removed from the body tissue without leaving any significant damage to the body tissue. In addition, the tissue connectors can be biocompatible tissue connectors that are designed to be left in the abdominal cavity after the surgery. Some examples of such tissue connectors include suture needles, "T" bars, graspers, barbed needles, hooks, clasps, rivet assemblies, or any other equivalent type of connector. The first and third tissue connectors are attached to the opposite ends of the first cord segment and the second and third tissue connectors are attached to the opposite ends of the second cord segment. This positions the first and second tissue connectors at the opposite ends of the combined lengths of the first and second cord segments, and positions the third tissue connector at an intermediate position of the combined lengths of the first and second cord segments.

[0013] In the use of the apparatus according to the method of the invention, the apparatus is first manually passed through the abdominal wall, for example through an incision or a cannula in the abdominal wall, and is positioned in the abdominal cavity in the area of the first and second internal organs. The third tissue connector is then manually connected to tissue adjacent the first internal organ. This positions the ends of the first and second cord segments connected to the third tissue connector between the first and second internal organs and on an opposite side of the first internal organ from the abdominal wall. The first tissue connector attached to the opposite end of the first cord segment from the third tissue connector is manually moved causing the length of the first cord segment to move and engage across the first internal organ and to move the first internal organ toward the position away from the second

internal organ. The first tissue connector is then manually connected to the abdominal wall.

[0014] The second tissue connector attached to the opposite end of the second cord segment from the third tissue connector is then manually moved causing the second cord segment to move and engage across the first internal organ and move the first internal organ toward the position away from the second internal organ. The second tissue connector is then manually connected to the abdominal wall.

[0015] In the above matter, the first and second cord segments engaging across the first internal organ hold the first internal organ at the position away from the second internal organ without further manual input. This provides surgical access to the second internal organ.

[0016] In a further embodiment of the apparatus of the invention, the apparatus is comprised of a cord having a continuous flexible length with opposite first and second ends. A needle is attached to one end of the length of cord and a knot is formed in the opposite end of the length of cord.

[0017] According to the method of use of this embodiment of the apparatus, the apparatus is first positioned inside the abdominal cavity in the same manner as the previously-described embodiment. The knotted end of the length of cord is then connected to tissue adjacent the first internal organ by first passing the needle through the tissue and then manually pulling the length of cord through the tissue. This attaches the knotted end of the cord to the tissue between the first and second internal organs.

[0018] The needle is then passed through the inter-abdominal wall and manually moved back into the abdominal cavity, causing a first segment of the length of cord to engage across the first internal organ and move the first internal organ toward the position away from the second internal organ.

[0019] The needle is then again inserted through the inter-abdominal wall at a location spaced from the first insertion of the needle through the inter-abdominal wall, and the needle and length of cord are pulled manually into the abdominal cavity.

[0020] The needle and the end of the length of cord attached to the needle are then passed through the knot formed at the opposite end of the length of cord and pulled tight, causing a second segment of the length of cord to engage across and move the first internal organ toward the position away from a second internal organ. A knot is then tied between the opposite ends of the length of cord and the portion of the cord extending from the knot to the needle is cut and removed with the needle from the abdominal cavity. The length of cord left in the abdominal cavity forms a triangular loop with first and second cord segments that engage across and hold the first internal organ in the position away from the second internal organ without manual input. In this manner, surgical access is provided to the second internal organ without manual input.

[0021] A still further embodiment of the apparatus of the invention is comprised of a cord having a continuous flexible length with opposite first and second ends, and a tissue connector assembly with a releasable one-way cord lock connected to an intermediate portion of the cord.

[0022] The tissue connector assembly has a base formed as a cylindrical housing. The base housing has a length with opposite first and second ends and a hollow interior bore

extending through the housing. A rod is attached to the base and is positioned in the interior bore adjacent the housing second end.

[0023] A first tissue connector is provided on the base and extends from the base first end. As in previous embodiments, the tissue connector can be any known type of tissue connector.

[0024] The intermediate portion of the cord length is attached to the base by being wrapped around the rod in the base housing. A first portion or first percentage of the cord length extends from the cord intermediate portion and from the base second end to the cord first end. A second portion or second percentage of the cord length extends from the cord intermediate portion and from the base second end to the cord second end.

[0025] A releasable one-way lock is mounted in the interior bore of the base for movement of the lock between first and second positions of the lock relative to the base. The lock is biased by a spring toward the first position. In the first position of the lock relative to the base, the lock engages with the intermediate portion of the cord wrapped around the rod and allows the cord first portion to be pulled from the base second end to thereby increase a length or percentage of the cord first portion while decreasing a length or percentage of the cord second portion, but the lock prevents the cord second portion from being pulled from the base second end. In the second position of the lock relative to the base the lock is disengaged from the cord and allows the cord second portion to be pulled from the base second end to thereby increase the length or percentage of the cord second portion while decreasing the length or percentage of the cord first portion.

[0026] A second tissue connector is provided at the cord second end. Again, the second tissue connector can be any known type of tissue connector. A percentage of the cord length extends between the first and second tissue connectors. This percentage of the cord length is adjustable.

[0027] There is an actuator on the base that is operatively connected to the lock. The actuator is movable between first and second positions of the actuator relative to the base. When the actuator is moved from the first position to its second position it causes the lock to move from its first position to its second position and releases the one way lock. The spring bias of the lock also biases the actuator from its second position toward its first position.

[0028] In the use of this embodiment of the apparatus according to the method of the invention, the apparatus is first positioned inside the abdominal cavity in the same manner as the previously described embodiments.

[0029] With the apparatus positioned in the abdominal cavity, the second tissue connector at the cord's second end is connected to tissue adjacent to the first internal organ or to the organ itself. The tissue connector assembly with the releasable one-way cord lock is then grasped at the actuator and moved toward the abdominal wall, causing the cord second portion to be extended across the first internal organ. When the cord second portion is pulled tight continued movement of the tissue connector assembly causes the actuator to move to its second position. This releases the lock and allows the cord second portion to be pulled from the base second end increasing the length or percentage of the cord second portion and decreasing the length or percentage of the cord first portion. The first tissue connector is then connected to the abdominal wall and the actuator is

released, causing the actuator and the lock to move to their first position due to the bias of the spring. The cord first portion is then grasped and pulled from the second end of the base. This in turn causes the length or percentage of the cord second portion to decrease. As the cord first portion is pulled from the base second end the length or percentage of the cord second portion continues to decrease and causes the cord second portion to engage across the first internal organ and move the first internal organ toward the position away from the second internal organ. With the releasable one-way lock biased to the first position relative to the base, the cord second portion cannot be pulled from the base.

[0030] In the above manner, the shortened length of the cord second portion extending between the first tissue connector connected to the abdominal wall and the second tissue connector connected to the body tissue adjacent the first internal organ engages across the first internal organ and holds the first internal organ at the position away from the second internal organ without further manual input. This provides surgical access to the second internal organ.

[0031] When it is desired to remove the apparatus of the invention, the actuator is grasped and moved from its first position to its second position relative to the apparatus base. This in turn causes the lock to move from its first position to its second position releasing the lock, and allows the cord second portion to be pulled from the base second end increasing the length or percentage of the cord second portion while decreasing the length or percentage of the cord first portion. This allows the cord second portion to disengage from the first internal organ and produces a sufficient length of the cord second portion to allow the first tissue connector to be removed from the abdominal wall and the second tissue connector at the cord second end to be removed from the body tissue adjacent the first internal organ or from the organ. The apparatus then can be removed from the abdominal cavity.

[0032] As described above, the embodiments of the apparatus of the invention and their methods of use enable intra-abdominally moving a first internal organ to a position away from a second internal organ where each of the embodiments of the apparatus holds the first internal organ in the position without manual input.

DESCRIPTION OF THE DRAWING FIGURES

[0033] Further features of the apparatus of the invention and its method of use are set forth in the following detailed description of the apparatus and method and are shown in the drawing figures.

[0034] FIG. 1 is a plan view of one embodiment of the apparatus of the invention.

[0035] FIG. 2 is a plan view of a further embodiment of the apparatus of the invention.

[0036] FIG. 3 is a plan view of a still further embodiment of the apparatus of the invention.

[0037] FIG. 4 is a representation of the apparatus of FIG. 1 being inserted into the abdominal cavity.

[0038] FIG. 5 is a representation of the apparatus of FIG. 1 being used according to the method of the invention.

[0039] FIG. 6 is a representation of the apparatus of FIG. 2 in use according to the method of the invention.

[0040] FIG. 7 is a representation of the apparatus of FIG. 3 in use according to the method of the invention.

[0041] FIGS. 8A-8E represent the insertion of one embodiment of the apparatus into the abdominal cavity and one method of use of the apparatus.

[0042] FIGS. 9A-9E represent the insertion of a further embodiment of the apparatus into the abdominal cavity and the method of using the apparatus.

[0043] FIGS. 10A and 10B represent the insertion of a further embodiment of the apparatus into the abdominal cavity and the method of using the apparatus.

[0044] FIGS. 11A and 11B represent a further embodiment of the apparatus and its method of use.

[0045] FIGS. 12A and 12B represent a further embodiment of the apparatus and its method of use.

[0046] FIGS. 13A and 13B represent a further embodiment of the apparatus and its method of use.

[0047] FIGS. 14A-14C represent a further embodiment of the apparatus and its method of use.

[0048] FIGS. 15A and 15B represent a further embodiment of the apparatus and its method of use.

[0049] FIGS. 16A and 16B represent a further embodiment of the apparatus and its method of use.

[0050] FIG. 17 represents a further embodiment of the apparatus and its method of use.

[0051] FIGS. 18A and 18B represent a further embodiment of the apparatus and its method of use.

[0052] FIGS. 19A and 19B represent a further embodiment of the apparatus and its method of use.

[0053] FIGS. 20A and 20B represent a further embodiment of the apparatus and its method of use.

[0054] FIGS. 21 A and 21B represent a further embodiment of the apparatus and its method of use.

[0055] FIGS. 22A and 22B represent a further embodiment of the apparatus and its method of use.

[0056] FIG. 23 represents a further embodiment of the apparatus and its method of use.

[0057] FIGS. 24A-24C represent component parts of a further embodiment of the apparatus.

[0058] FIG. 25 represents a component part of a further embodiment of the apparatus.

[0059] FIG. 26 represents a component part of a further embodiment of the apparatus.

[0060] FIG. 27 represents represent a further embodiment of the apparatus.

[0061] FIG. 28 represents represent a further embodiment of the apparatus.

[0062] FIG. 29 represents a further embodiment of the apparatus.

[0063] FIG. 30 represents a further embodiment of the apparatus.

[0064] FIG. 31 represents a further embodiment of the apparatus.

[0065] FIG. 32 represents a further embodiment of the apparatus.

[0066] FIG. 33 represents a component part of an embodiment of the apparatus.

[0067] FIG. 34 represents a component part of an embodiment of the apparatus.

[0068] FIG. 35 represents a component part of an embodiment of the apparatus.

[0069] FIG. 36 represents a component part of an embodiment of the apparatus.

[0070] FIG. 37 represents a component part of an embodiment of the apparatus.

[0071] FIG. 38 represents a component part of an embodiment of the apparatus.

[0072] FIGS. 39A-39C represent component parts of an embodiment of the apparatus.

[0073] FIGS. 40A and 40B represent component parts of an embodiment of the apparatus.

[0074] FIG. 41 represents a component part of an embodiment of the apparatus.

[0075] FIG. 42 represents a component part of an embodiment of the apparatus.

[0076] FIG. 43 represents a component part of an embodiment of the apparatus.

[0077] FIGS. 44A and 44B represent component parts of an embodiment of the apparatus.

[0078] FIGS. 45A-45E represent component parts of an embodiment of the apparatus.

[0079] FIGS. 46A-46E represent component parts of an embodiment of the apparatus and its method of use.

[0080] FIGS. 47A-47D represent component parts of an embodiment of the apparatus and its method of use.

[0081] FIGS. 48A-48D represent component parts of an embodiment of the apparatus and its method of use.

[0082] FIGS. 49A and 49B represent component parts of an embodiment of the apparatus and its method of use.

[0083] FIGS. 50A and 50B represent component parts of an embodiment of the apparatus and its method of use.

[0084] FIGS. 51A-51E represent a method of positioning an embodiment of the apparatus in an abdominal insertion device.

[0085] FIGS. 52A and 52B represent embodiments of the apparatus and an insertion device and the method of mounting the apparatus on the insertion device.

[0086] FIG. 53 represents embodiments of the apparatus and an insertion device and a method of mounting the apparatus on the insertion device.

[0087] FIG. 54 represents embodiments of the apparatus and an insertion device and a method of mounting the apparatus in the insertion device.

[0088] FIGS. 55A-55C represent an embodiment of the apparatus and a method of using the apparatus.

[0089] FIGS. 56A-56C are views of a further embodiment of the apparatus of the invention that employs a tissue connector with a releasable one-way cord lock.

[0090] FIGS. 57A-57C are views of the tissue connector apparatus of FIGS. 56A-56C but rotated 90°. FIGS. 58A-58C are views of the tissue connector apparatus similar to those of FIGS. 56A-56C, but with the releasable one-way cord lock moved to an unlocked position.

[0091] FIGS. 59A-59C are views of the surgical tissue connector apparatus shown in FIGS. 58A-58C, but rotated 90°.

[0092] FIGS. 60A-60C show a further embodiment of the surgical tissue connector apparatus with a releasable one-way cord lock.

[0093] FIGS. 61A-61C are views of the tissue connector apparatus of FIGS. 60A-60C, but rotated 90°.

[0094] FIGS. 62A-62C are views of the tissue connector apparatus similar to those of FIGS. 60A-60C, but with the releasable one-way cord lock moved to the unlocked position.

[0095] FIGS. 63A-63C are views similar to those of FIGS. 62A-62C, but rotated 90°.

[0096] FIGS. 64-67 are representations of a method of using either of the embodiments of the surgical tissue connector apparatus shown in FIGS. 56A-56C or 60A-60C.

[0097] FIG. 68 is a view of a still further embodiment of the apparatus comprising two cord lengths and four tissue connectors.

DETAILED DESCRIPTION OF THE PREFERRED EMBODIMENT

[0098] FIG. 1 shows one embodiment 12 of the apparatus for intra-abdominally moving a first internal organ to a position away from a second internal organ and then holding the first internal organ in the position without manual input. As stated earlier, the apparatus 12 is constructed of component parts that are often used in laparoscopic instruments and procedures as well as other types of surgical instruments and procedures. Because such component parts are known, the component parts that make up the apparatus 12 of the invention will be described herein using their common understood names and functions, without going into the details of the particular constructions of the component parts. As is conventional with laparoscopic apparatus, the component parts of the apparatus are dimensioned to be inserted through an incision in the abdominal wall or through a cannula extending through the abdominal wall to position the apparatus in the abdominal cavity.

[0099] The basic construction of the apparatus 12 of the invention includes a length of cord. In the example of FIG. 1 the cord length is 10 inches, but the size of the apparatus 12 could change depending on the size of the patient in which the apparatus is used. In the embodiment shown in FIG. 1, the cord is comprised of a first cord segment 14 having a flexible length with opposite first 16 and second 18 ends, and a second cord segment 22 having a flexible length with opposite first 24 and second 26 ends.

[0100] The cord segments 14, 22 could be provided by lengths of suture, lengths of tubing such as IV tubing, lengths of umbilical tape or elastic strips, or other equivalent cord constructions. The tubing or tape configurations of the cord segments have the advantage of being less likely to dig into or cut into the first internal organ in use of the apparatus to be described. The first 14 and second 22 cord segments could be separate cord segments that are attached directly together, or separate cord segments that are attached by way of a further cord segment 28 or some other component part of the apparatus, or two cord segments of a single continuous length of cord such as the two cord segments 14a, 22a shown in FIG. 2.

[0101] First 32, second 34, and third 36 separate tissue connectors are attached to the first 14 and second 22 cord segments. The tissue connectors 32, 34, 36 can be any type of known tissue connector that can be manually manipulated to connect to body tissue, and then manually manipulated to be removed from the body tissue 12 without leaving any significant damage to the body tissue. In addition, the tissue connectors 32, 34, 36 could be biocompatible tissue connectors that are designed to be left in the abdominal cavity after the surgical procedure is completed. Some examples of tissue connectors include suture needles, T bars, surgical graspers, barbed needles, hooks, clasps, rivet assemblies, or any other equivalent type of connector. In the apparatus of the invention, it is not necessary that all three tissue connectors 32, 34, 36 be the same type of tissue connector. Because various different types of tissue connectors may be

employed with the apparatus 12 of the invention, the three tissue connectors 32,34,36 of the apparatus 12 are represented schematically in the drawing figures. The first 32 and third 36 tissue connectors are attached to the opposite ends of the first cord segment 14. The third tissue connector 36 is also attached to one end of the second cord segment 22, with the second tissue connector 34 being connected to the opposite end of the second cord segment 22. This positions the first 32 and second 34 tissue connectors at the opposite ends of the combined lengths of the first 14 and second 22 cord segments, and positions the third tissue connector 36 at an intermediate position of the combined length of the first 14 and second 22 cord segments. In FIG. 1, the first 32 and second 34 tissue connectors are shown connected to the respective first end 16 of the first cord segment 14 and the first end 24 of the second cord segment 22 through the intermediary of additional cord segments 38, 40. The third tissue connector 36 is shown connected to the second end 18 of the first cord segment 14 and the second end 26 of the second cord segment 22 through the intermediary of a further cord segment 28. FIG. 2 shows the apparatus 12 with the first 32 and second 34 tissue connectors connected directly to the respective first end 16 of the first cord segment 14 and the first end 24 of the second cord segment 22. FIG. 2 also shows the third tissue connector 36 connected directly to the second ends 18, 26 of the first cord segment 14 and the second cord segment 22.

[0102] FIGS. 4 and 5 illustrate an example of the use of the apparatus 12 of FIG. 1 according to the method of the invention. In use, the apparatus 12 is first manually passed through the abdominal wall 42, for example through an incision or a cannula 44 in the abdominal wall 42, and is positioned in the abdominal cavity 46 in the area of the first 48 and second 50 internal organs. In FIG. 4, the first internal organ 48 represented is the human liver, and the second internal organ 50 represented is the human stomach.

[0103] The third tissue connector 36 of the apparatus is then manually connected to tissue 52 adjacent the first internal organ 48 and between the first 48 and second 50 internal organs. In the example shown in FIG. 4, the tissue 52 is the crus of the diaphragm. Connection of the third tissue connector 36 to the tissue 52 positions the second ends 18, 26 of the first 14 and second 22 cord segments connected to the third tissue connector 32 between the first 48 and second 50 internal organs and on an opposite side of the first internal organ 48 from the abdominal wall 42.

[0104] The first tissue connector 32 attached to the opposite end 16 of the first cord segment 14 from the third tissue connector 36 is then manually moved causing the length of the first cord segment 14 to move and engage across the first internal organ 48. Continued movement of the first tissue connector 32 causes the first cord segment 14 engaging across the first internal organ 48 to move the first internal organ toward a position away from the second internal organ 50. The first tissue connector 32 is then manually connected to the inner abdominal wall 42.

[0105] The second tissue connector 34 attached to the opposite end 24 of the second cord segment 22 from the third tissue connector 36 is then manually moved causing the second cord segment 22 to move and engage across the first internal organ 48. Continued movement of the second tissue connector 34 causes the second cord segment 22 engaging across the first internal organ 48 to move the first internal organ 48 toward the position away from the second

internal organ 50. The second tissue connector 34 is then manually connected to the inner abdominal wall 42.

[0106] With the apparatus 12 connected between the tissue 52 and the inner abdominal wall 42 in the manner discussed above, the first cord segment 14 and the second cord segment 22 engage across the first internal organ 48 and hold the first internal organ 48 at the position away from the second internal organ 50 without further manual input. This provides surgical access to the second internal organ 50. Without requiring manual holding or restraining of the first internal organ 48 in the position away from the second internal organ 50.

[0107] FIG. 6 is a representation of the apparatus of FIG. 2 that has been connected between the tissue 52 and the inner abdominal wall 42 according to the same method as the apparatus of FIG. 1 described above.

[0108] In a further embodiment of the apparatus of the invention shown in FIG. 3, the apparatus 54 is comprised of a single cord 56 having a continuous flexible length with opposite first 58 and second 60 ends. A tissue connector in the form of a needle 62 is attached to the first end 58 of the length of cord 56. At the opposite second end 60 of the length of cord 56, the cord is formed in a knot 64.

[0109] The method of using the embodiment of the apparatus 54 shown in FIG. 3 is illustrated in FIG. 7. The apparatus 54 is first positioned inside the abdominal cavity in the same manner as the previously described embodiments. The knotted end 64 of the length of cord is then connected to the tissue 52 adjacent the first internal organ 48 by first passing the needle 62 through the tissue 52 and then manually pulling the needle 62 and the attached length of cord 56 through the tissue 52. This attaches the knotted second end 64 of the length of cord 56 to the tissue 52 between the first 48 and second 50 internal organs.

[0110] The needle 62 is then passed through the inter-abdominal wall 42 and the needle 62 and the attached length of cord 56 are pulled from the insertion site 72 back into the abdominal cavity 46. This causes a first segment 74 of the cord length 56 to move into engagement with and across the first internal organ 48. The engagement of the first cord segment 74 with the first internal organ 48 moves the first internal organ 48 toward the position away from the second internal organ 50.

[0111] The needle 62 is then again inserted through the inter-abdominal wall 42 at a second insertion location 76 spaced from the first insertion location 72. The needle 62 and the attached length of cord 56 are pulled manually through the second insertion 76 into the abdominal cavity 46 until an intermediate section of cord 78 extends between the two insertion sites 72,76.

[0112] The needle 62 and the attached length of cord 56 are then passed through the knot 64 formed at the opposite end of the length of cord 56 and are pulled tight. This causes a second cord segment 82 of the length of cord 56 to engage across and move the first internal organ 48 toward the position away from the second internal organ 50. The length of cord 56 is pulled tight and a knot is tied between the opposite ends of the cord at the knot 64 on the cord second end 60. The portion of the length of cord 54 extending from the knot 64 to the needle 62 is then cut and removed from the abdominal cavity. The length of cord 54 left in the abdominal cavity forms a triangular loop with the first 56 and second 82 cord segments extending across the first internal organ 48 and holding the first internal organ in the

position away from the second internal organ **50** without manual input. In this manner, surgical access is provided to the second internal organ **50** without manually holding the first internal organ **48** in its retracted position.

[0113] FIGS. **8A-8E** represent one method of inserting the apparatus of the invention into the abdominal cavity and the method of using the apparatus. The embodiment of the apparatus **12** shown in these drawing figures has a pair of keith needles **80, 82** as the first and second tissue connectors, and a T bar **84** as the third tissue connector. The apparatus **12** is first positioned inside an insertion device **86** in the form of a hollow narrow tube. The insertion device **86** is then inserted through a trocar or cannula **44** that has been positioned in the abdominal wall **42** in a conventional manner. Once inside the abdominal cavity **46**, the apparatus **12** is removed from the interior of the insertion device **86** and the insertion device is removed from the abdominal cavity through the cannula **44**. The T bar **84** or the third tissue connector is then passed through the body tissue **52**, i.e., the right diaphragm crus as described earlier. Once the T bar **84** is passed through the tissue **52**, it is rotated to its substantially 90 degree position relative to its pathway through the tissue **52** as shown in FIG. **8C**. The apparatus **12** is then pulled from the keith needles **80, 82**. As represented in FIG. **80**, the keith needles **80, 82** are then passed through the abdominal wall **42** and the apparatus is pulled tight against the first internal organ **48**, i.e., the liver. The needles **80, 82** are then pulled at the exterior of the abdominal wall **42**, causing the apparatus to move the first internal organ **48** away from the second internal organ, i.e., the stomach. A pair of tension clasps **88, 90** are attached to the respective first **14** and second **22** cord segments of the apparatus on the exterior of the abdominal wall **42** to hold the apparatus in its position across the first internal organ **48** in the abdominal cavity **46**.

[0114] FIGS. **9A-9E** represent a method of using an embodiment of the apparatus **12** that is similar to that shown in FIGS. **8A-8E** and described above. In this example, the apparatus **12** also employs the T bar **84** as its third tissue connector. However, there is no needle provided on the first cord segment **14** and there is no needle provided on the second cord segment **22**. In this embodiment of the apparatus **12**, the first cord segment **14** is a length of suture having a free end **92** opposite the T bar **84** and the second cord segment **22** is a length of suture also having a free end **94** opposite the T bar **84**. The apparatus **12** is shown in FIG. **9A** as being positioned in the abdominal cavity **46** using the insertion device **86** in the same manner described earlier with reference to the method of FIGS. **8A-8E**. The apparatus **12** of FIG. **9A** is also initially used according to the same method of FIGS. **8A-8E** in that the "T" bar **84** is passed through the body tissue **52** and is positioned substantially 90° relative to the pathway through the tissue. A pair **18** of GraNee needles **96, 98** are then passed through the abdominal wall **42**. One of the GraNee needles **96** grabs the suture free end **92** of the first cord segment **14** and the other GraNee needle **98** grabs the suture free end **94** of the second cord segment **22**. The GraNee needles **96, 98** are then withdrawn through the abdominal wall **42** pulling the suture free ends **92, 94** through the abdominal wall. The suture free ends **92, 94** are then secured to the abdominal wall using a pair of clamps **88, 90** as was done in the previously-described embodiment of FIGS. **8A-8E**.

[0115] FIGS. **10A** and **10B** are a representation of the method of the invention practiced using an ENDO STITCH® device marketed by United States Surgical Corporation. FIG. **10A** represents the distal end of the ENDO STITCH® **102** being inserted through the cannula **44** in the abdominal wall **42** to a position adjacent the diaphragm crus **52**. As is conventional, the pair of jaws **104, 106** at the ENDO STITCH® distal end **102** hold a needle **108** and a length of suture **110**. The ENDO STITCH® **102** is manually actuated to pass the needle **108** through the tissue **52** of the crus from one jaw **104** of the ENDO STITCH® to the opposite jaw **106** of the ENDO STITCH®. The length of suture **110** is then removed from the abdominal cavity **46** through the cannula **44** and is pulled tight, causing the length of suture **110** to move and hold the first internal organ away from the second internal organ in substantially the same manner as described earlier.

[0116] FIGS. **11A** and **11B** represent a further embodiment of the apparatus **12** and its method of use. The embodiment of the apparatus **12** shown in FIGS. **11A** and **11B** and its method of use are substantially the same as that of earlier-described embodiments, except that the T bar of the previously-described embodiments is replaced by a "J" hook locking clasp **112**. FIG. **11A** shows the locking clasp **112** in its open position prior to the hook portion of the clasp being passed through the tissue **52** of the diaphragm crus. FIG. **11B** shows the locking clasp **112** after the hook of the clasp has been passed through the tissue **52** and the clasp has been locked. The method of further using the apparatus to move and hold an internal organ is substantially the same as that of earlier-described embodiments.

[0117] FIGS. **12A** and **12B** show a further embodiment of the apparatus **12** and its method of use. The construction of the embodiment of the apparatus **12** shown in FIGS. **12A** and **12B** is substantially the same as earlier described embodiments, except that the bar or locking clasp is replaced by a barbed needle **114**. The method of using the embodiment of the apparatus shown in FIGS. **12A** and **12B** is substantially the same as that of earlier described embodiments, except that the barbed needle **114** is passed through the tissue **52** of the diaphragm crus until the barb of the needle emerges from the tissue as shown in FIG. **12B**. This secures the apparatus to the tissue **52**. Further use of the apparatus to move and hold an internal organ is substantially the same as that of earlier-described embodiments.

[0118] FIGS. **13A** and **13B** show a further embodiment of the apparatus **12** of the invention that is substantially the same as that as earlier-described embodiments except that the third tissue connector or T bar is replaced by a resilient biased clasp **116**. In the method of using the apparatus of FIGS. **13A** and **13B**, the opposite arms **118, 120** of the clasp **116** are compressed to open the jaws **122, 124** of the clasp as shown in FIG. **13A**. The jaws **122, 124** are then positioned around the tissue **52** of the diaphragm crus and are allowed to close, thereby securing the clasp **116** to the tissue **52**. The subsequent method of using the apparatus shown in FIGS. **13A** and **13B** is substantially the same as that of previously-described embodiments of the apparatus.

[0119] FIG. **14A-14C** show a further embodiment of the apparatus **12** that is substantially the same as that of previously-described embodiments except that the third tissue connector is a two-piece rivet assembly. The assembly is comprised of a pin **126** having an enlarged point **128** and a cap **130** having a circular center opening **132**. In the method

of using the apparatus of FIGS. 14A-14C, the pin 126 is first inserted through the tissue 52 of the diaphragm crus until the point 128 projects from the opposite side of the tissue. The point 128 is then inserted through the center opening 132 of the cap 130, thereby securing the pin 126 and the cap 130 to the tissue 152. The subsequent steps of using the apparatus of FIGS. 14A-14C is substantially the same as that of earlier-described embodiments of the apparatus.

[0120] FIGS. 15A and 15B show a further embodiment of the apparatus 12 that has substantially the same construction of earlier-described embodiments of the apparatus except for the first and second tissue connectors being a pair of "J" shaped hooks 134, 136. In the method of using the embodiment of the apparatus shown in FIGS. 15A and 15B, the first cord segment 14 and the second cord segment 22 are secured to the inner abdominal wall 42 by passing the hooks 134, 136 through the tissue of the inner abdominal wall. Apart from this, the method of using the apparatus shown in FIGS. 15A and 15B is substantially the same as that of earlier-described embodiments of the apparatus.

[0121] FIGS. 16A and 16B represent a further embodiment of the apparatus and its method of use that are substantially the same as that of previously-described embodiments, except for the first and second tissue connectors being a pair of "J" hook locking clasps 138, 140. In the method of using the apparatus of FIGS. 16A and 16B, the hook portions of the locking clasps 138, 140 are passed through the tissue of the inner abdominal wall 42 and then are locked closed. This secures the first cord segment 14 and the second cord segment 22 to the inner abdominal wall. Apart from this, the method of using the apparatus of the invention shown in FIGS. 16A and 16B is substantially the same as that of earlier-described embodiments of the apparatus.

[0122] FIG. 17 shows a representation of an embodiment of the apparatus where the first and second tissue connectors are provided as a pair of resilient, biased clasps 142, 144 that have substantially the same construction of the earlier described clasp 116. The clasps 142, 144 are secured to the inner abdominal wall 42 by first opening the clasps and positioning tissue of the inner abdominal wall between the open jaws of the clasps, and then allowing the jaws of the clasps to close over the tissue. This secures the first cord segment 14 and the second cord segment 22 to the inner abdominal wall. Apart from this, the method of using the apparatus represented in FIG. 17 is substantially the same as that as earlier described embodiments of the apparatus.

[0123] FIGS. 18A and 18B show an embodiment of the apparatus and its method of use that is substantially the same as that of FIG. 7. The embodiment of FIGS. 18A and 18B differs from that of the FIG. 7 embodiment in that the free ends 146, 148 of the length of suture 150 are tied in a knot completing the triangular loop configuration of the length of suture 150 at a location that is displaced from the portion of the suture 150 passed through the tissue 52 of the diaphragm crus. Apart from this, the method of using the apparatus of the invention shown in FIGS. 18A and 18B is substantially the same as that of the embodiment of the apparatus shown in FIG. 7.

[0124] FIGS. 19A and 19B show a further embodiment of the apparatus and its method of use. The apparatus shown in these drawing figures is comprised of a length of cord 152 with a circular pledget 154 secured at one end of the cord and a needle, for example a Keith needle 156, secured to the

opposite end of the cord. The cord 152 could be a length of suture or other similar material. In the method of using the apparatus shown in FIGS. 19A and 19B, the needle 156 is first passed through the abdominal wall 42 and into the abdominal cavity 46. The needle 156 is then passed through the tissue 52 of the diaphragm crus. The needle 156 is then again passed through the abdominal wall 42 to the exterior of the abdomen and is pulled tight. This results in the length of cord 152 engaging against and moving the first internal organ away from the second internal organ in substantially the same manner as previously-described embodiments. The tight length of cord 152 is then secured in place by a clasp 158 attached to the length of cord 152 against the exterior of the abdominal wall 42.

[0125] FIGS. 20A and 20B show a representation of a further embodiment of the apparatus and its method of use. In FIG. 20A, the apparatus is shown comprised of a length of cord 160 having a circular pledget 162 at one end and a needle, for example a Keith needle 164, at the opposite end. The apparatus also includes a second shorter length of cord 166 with a T bar 168 at one end and a loop 170 formed in the opposite end. In the embodiment, the cords 160, 166 may be suture or other similar materials. The method of using the apparatus is represented in FIG. 20B. The T bar 168 is first secured to the tissue 52 of the diaphragm crus. The needle 164 is then passed through the tissue of the inner abdominal wall 42, through the loop 170 and then through the abdominal wall 42 to the exterior of the abdomen. Pulling the needle 164 on the exterior of the abdomen pulls the cord 160 tight across the internal organ to move and hold the internal organ in substantially the same manner as that of previously-described embodiments of the apparatus.

[0126] FIGS. 21A and 21B show a further embodiment of the apparatus that is substantially the same as that of the embodiment of FIGS. 20A and 20B, except that the needle 164 is removed from the end of the length of cord 160, leaving a free end 172 of the cord. The method of using this embodiment of the apparatus is substantially the same as that of the previously-described embodiment except for the step of passing the cord free end 172 through the abdominal wall 42. A GraNee needle (not shown) may be used to perform this step of the method.

[0127] FIGS. 22A and 22B show a further embodiment of the apparatus that is substantially the same as that of the previously-described embodiment, except that it is comprised of only the length of cord 160 having the circular pledget 162 at one end and a free end 172 of the cord at the opposite end. In the method of using this embodiment of the apparatus, the suture free end 172 is first passed through the inner abdominal wall 42, then through the tissue 52 of the diaphragm crus, and then through and out of the abdominal wall 42. As in the previously-described embodiment, the suture free end 172 can be passed through the tissue of the abdominal wall 42 and the crus 52 using a GraNee needle or other similar instrument. The length of cord 160 is pulled tight to move and hold the first internal organ relative to the second internal organ in substantially the same manner as previously-described method embodiments of the apparatus.

[0128] FIG. 23 shows a further embodiment of the apparatus that is substantially the same as that of earlier-described embodiments except for the first and second tissue connectors being "J" hook locking clasps 174, 176 that incorporate one-way clutch mechanisms. The ends of the cord segments 14, 22 can be pulled through the clutch

mechanisms of the clasps **174**, **176** in one direction, but are prevented by the clutch mechanisms from being pulled through the clasps **174**, **176** in the opposite directions.

[0129] FIG. 24A-24C show representations of a “J” hook locking clasp such as that shown in FIG. 23, with a one-way clutch mechanism. The one-way clutch mechanism is comprised of a rotatable pulley **178** and a “V” shaped groove **180** positioned adjacent the pulley **178**. An end portion of the cord **182** is threaded through the “V” shaped groove **180** and then around the pulley **178**. When the end of the cord **182** extending from the pulley **178** is pulled tight, the relative positions of the pulley **178** and the groove **180** cause the portion of the cord **182** to wedge and become locked in the bottom of the groove **180**.

[0130] FIG. 25 shows a further representation of the embodiment of the apparatus employing a “J” hook locking clasp **184** with a one-way clutch mechanism. The one-way clutch mechanism is comprised of a pair of pivoting cams **186**, **188** having opposing ratchet tooth surfaces **190**, **192**. A portion of the apparatus cord **194** is threaded between the opposed tooth surfaces. The portion of cord **194** can be pulled through the spacing between the cam ratchet tooth surfaces **190**, **192** in one direction, for example to the left in FIG. 25, but the cams **186**, **188** pivot toward each other and their ratchet tooth surfaces **190**, **192** clamp the cord portion **194** between the surfaces when the cord portion is pulled in the opposite direction, for example to the right as shown in FIG. 25.

[0131] FIG. 26 shows a representation of a further embodiment of the “J” hook clasp **196** having a one-way clutch mechanism. In this embodiment, the one-way clutch mechanism is comprised of a toothed wheel **198** that engages with the cord portion **20** pulled through the clasps **196**. The tooth wheel **198** also has a smaller ratchet wheel **202** at its center. The ratchet wheel **202** engages against a resilient pawl **204**. The ratchet wheel **202** and resilient pawl **204** function in the conventional manner allowing the toothed wheel **198** to rotate in one direction when the cord portion **200** is pulled through the clutch mechanism, for example to the right as shown in FIG. 26, but prevent the rotation of the toothed wheel **198** and the movement of the cord portion **200** when the cord portion is pulled in the opposite direction, for example to the left as shown in FIG. 26.

[0132] FIGS. 27-32 show several different representations of the possible constructions of the cord segments **14**, **22**, **38** of the apparatus of the invention. In FIGS. 27-32 the first and second tissue connectors are represented by needles, for example Keith needles **80**, **82**. The third tissue connector is represented by a T bar **84**. It should be understood that these are only examples of only three tissue connectors that could possibly be used with the apparatus of the invention, and that other forms of tissue connectors, for example the types described herein could be used as the three tissue connectors on the apparatus. FIG. 27 shows the first **14**, second **22** and third **38** cord segments as being constructed of suture material.

[0133] FIG. 28 shows the first **14** and second **22** cord segments being part of a single length of surgical tape or strap, and the third cord segment **38** being constructed of suture.

[0134] FIG. 29 shows the first **14** and second **22** cord segments being constructed of lengths of suture inserted through lengths of surgical tubing. The third cord segment **38** is constructed of suture.

[0135] FIG. 30 shows the apparatus as having first **14** and second **22** cord segments constructed of combinations of surgical tape and suture connected end to end. The third cord segment **38** is constructed of suture material.

[0136] FIG. 31 shows the apparatus being constructed of first **14** and second **22** cord segments formed from a single length of suture material inserted through a single length of surgical tubing. The third cord segment **38** is constructed of suture material.

[0137] FIG. 32 shows the apparatus as having the first **14** and second **22** cord segments constructed of a single continuous length of surgical tape having lengths of suture at opposite ends. The third cord segment **38** is constructed of suture material.

[0138] FIGS. 33-45 show examples of some of the various different types of tissue connectors that could be used as anyone of the tissues connectors **32**, **34**, **36** of the apparatus. These are only some of the possible types of tissue connectors, and the connectors shown in FIGS. 33-45 should not be interpreted as limiting the apparatus to the particular tissue connectors shown.

[0139] FIG. 33 shows a T bar **84** as one example of anyone of the three tissue connectors **32**, **34**, **36**.

[0140] FIG. 34 shows a barbed needle **114** as anyone of the three tissue connectors **32**, **34**, **36**.

[0141] FIG. 35 shows the two-piece rivet pin **126** and cap **130** connector that can be used as anyone of the three tissue connectors **32**, **34**, **36**.

[0142] FIG. 36 shows the “j” hook locking clasp **112** that can be used as anyone of the three tissue connectors **32**, **34**, **36**.

[0143] FIG. 37 shows the resilient, biased clasp **116** that could be used as any one of the three tissue connectors **32**, **34**, **36**.

[0144] FIG. 38 shows a cross-section of an embodiment of a “j” hook locking clasp. The embodiment shown is comprised of a cylindrical housing **206** that contains the “j” hook **208** and a coil spring **210** that biases the “j” hook **208** to its closed position.

[0145] FIGS. 39A-39C show a variation of the “j” hook locking clasp of FIG. 38 where the coil spring **210** is replaced by a spiral band spring **212**. FIG. 39B shows the spiral and spring **212** in its extended configuration, and FIG. 39C shows the spring in its compressed configuration.

[0146] FIGS. 40A and 40B show a tissue connector clasp that is comprised of a pair of resilient jaws **214**, **216** that project from one end of a hollow housing **218**, and a pin **220** connected to the jaws that projects from the opposite end of the housing. A spring **222** contained in the housing **218** biases the pin **220** and the jaws **214**, **216** to the left as shown in FIG. 40A. This causes the resilient jaws to move to their open position shown in FIG. 40A. Pulling the pin **220** to the right against the bias of the spring **222** causes the housing to slide against the opposite sides of the jaws **214**, **216** and move the jaws to their closed position.

[0147] FIG. 41 shows a side view of the resilient biased clasp **116** described earlier. Compressing the opposite arms **118**, **120** of the clasp **116** causes the jaws **122**, **124** to

separate. Releasing the compression force causes the jaws **122, 124** to move together under the bias of the resilience of the clasp **116**.

[0148] FIG. **42** shows an embodiment of a clasp comprised of a first jaw **224** and first arm **226** connected by a pivot connection **228** to a second jaw **230** and second arm **232**. An oblong cam **234** on a toothed cam wheel **236** is positioned between the pair of arms **226, 232**. A toothed actuator wheel **238** meshes with the toothed cam wheel **236**. Rotation of the actuator wheel **238** will cause rotation of the cam wheel **236** and the cam **238**. Rotation of the cam **234** to its position shown in FIG. **42** pushes the pair of arms **226, 232** away from each other which in turn causes the pair of jaws **224, 230** to move toward each other. Rotation of the cam **234** 90° or one-quarter turn from its position shown in FIG. **2** will cause the jaws **242, 230** to move away from each other.

[0149] FIG. **43** shows an embodiment of a clasp comprised of a first jaw **240** and first arm **242** connected by a pivot connection **244** to a second jaw **246** and second arm **248**. A spring **250** is positioned between the pair of arms **240, 248** and biases the arms away from each other. This in turn biases the first jaw **242** and second jaw **246** toward each other. The jaws **242, 246** are opened by applying a compression force to the opposite sides of the first arm **240** and second arm **248** that compresses the spring **250**.

[0150] FIGS. **44A-44B** show a side-sectioned view of a construction of the rivet assembly described earlier. As seen in the drawing figures, the pin head **128** is slightly larger in diameter than the cap hole **132**. When the pin **126** is attached to the cap **130**, there is a fixed gap or maximum distance between a circular head **252** of the pin **126** and the cap **130**.

[0151] FIGS. **45A-45E** show a further embodiment of a rivet assembly. In this assembly, the rivet pin **254** has several notches **256** along its length between the pin head **258** and the pin point **260**. The rivet cap **262** is similar in construction to that of the previously-described embodiment with a center opening or hole **264** extending through the cap. However, the cap **262** is also formed with a transverse slot **266** that intersects the center hole **264** and a parallel slot **268** that extends into the cap **262** parallel to the center hole **264** and intersects the transverse slot **266**. A locking tab **270** with a pin hole **272** and a spring hole **274** is inserted in the transverse slot **266** for sliding movement therein. A resilient wire spring **276** is inserted downwardly into the parallel slot **268** and through the tab pin hole **272**. Inserting the rivet pin **254** into the cap center hole **264** and through the tab pin hole **272** causes the pin to slide the **30** tab to the left as shown in FIG. **45A** against the bias of the wire spring **276**. As a pin notch **256** passes through the tab hole **272**, the bias of the spring **276** causes the tab **270** to move to the right and into the notch **256**. This locks the pin **254** in place relative to the cap **262**. With the pin **254** having a number of notches, and in the example of FIG. **45A** having three notches, the position of the pin head **258** relative to the cap **262** can be adjusted between three positions. This provides an adjustable gap or an adjustable distance between the pin head **258** and the cap **262**.

[0152] FIGS. **46A-46E** represent a further embodiment of the apparatus of the invention. This embodiment is comprised of a length of cord **278** having a needle **280** at one end and a loop **282** formed at the opposite end. A circular pledget **284** is provided on the length of cord **278** toward the loop end of the cord. The apparatus also includes a locking collar

having a hollow cylindrical housing **286** that contains a tubular one-way suture lock **288**. The suture lock **288** is basically cylindrical but is formed with a resilient tab **290** that projects toward the center of the cylindrical configuration of the suture lock. FIG. **46E** shows a cross-section representation of the collar cylindrical housing **286** containing the one-way suture lock **288** and a portion of the length of cord **278** extending through the collar. The method of using this embodiment of the apparatus is shown in FIG. **46C**. In use in the abdominal cavity **46**, the needle **280** is first passed through the tissue **52** in the area of the diaphragm crus, and then is passed a first time through the inner abdominal wall **42**. The needle **280** is then moved across the inner abdominal wall **42** and is again passed a second time through the inner abdominal wall. The needle is then inserted through the loop **282** and is pulled tight. This causes the length of cord **278** to form a triangular loop in the abdominal cavity that moves the first internal organ away from the second internal organ and holds the first internal organ in the displaced position in the same manner as previously-described methods of using the apparatus of the invention. The needle **280** is then passed through the collar cylindrical housing **286** and the housing **286** is moved tight against the cord loop **282**. The cord loop **282** is smaller than the housing **286** so that the housing cannot pass through the loop **282**. As the length of cord **278** is pulled through the collar housing **286**, the locking tab **290** engages against the side of the cord **278** as shown in FIG. **46E**. This allows the cord **278** to move through the collar housing **286** in the direction to the right shown in FIG. **46E**, but prevents movement of the cord to the left as shown in the figure. In this manner, the apparatus of FIGS. **46A-46E** holds the length of cord tight in its triangular loop configuration.

[0153] FIGS. **47A** and **47B** show a further embodiment of the apparatus of the invention and its method of use. The apparatus is comprised of a length of cord **294** having a pledget **296** secured at one end and a needle **298** secured at the opposite end. The apparatus also includes a one-way locking mechanism **300** having a pair of channels **302, 304** through the mechanism dimensioned to receive the length of cord **294**. One of the channels **302** allows the length of cord **294** to move through the channel in one direction, but prevents the opposite direction of movement. The other channel **304** allows the length of cord **294** to move through the channel in one direction, but also prevents the opposite direction of movement of the cord **294**. As represented in FIG. **47A**, the method of using the apparatus first involves the needle **298** passing through the inner abdominal wall until the pledget **296** is positioned up against the wall. The needle **298** then passes through the tissue **52** in the area of the diaphragm crus. The needle **298** is then inserted through the first channel **302** of the one-way locking mechanism **300**. The needle **298** is then again passed through the inner abdominal wall at a location spaced from the first insertion site and is then passed through the second channel **304** of the one-way locking mechanism **300**. The needle **298** with the length of cord **294** are then pulled tight and the locking mechanism **300** is moved up against the inner abdominal wall at the second needle insertion site. This causes the length of cord **294** to move the first internal organ and hold the first internal organ in its moved position away from the second internal organ in a similar manner to that of earlier-described embodiments.

[0154] FIGS. 47C and 47D show the interior of one embodiment of the one-way locking mechanism 300. The mechanism 300 includes a housing first half 306 and a second half 308 that are connected together by a living hinge 310. The open position of the locking mechanism is shown in FIG. 47D. The interior of the two halves 306,308 of the locking mechanism are formed with grooves 312,314 that form the two channels 302,304 through the locking mechanism when the two halves 306, 308 of the locking mechanism are pivoted about the living hinge 310 and snapped together. A “U” shaped spring member 316 is positioned in the first locking mechanism half 306. The spring member 316 has a pair of arms 318,320 that project from opposite sides of the spring member. Each arm 318, 320 in turn has a resilient locking tab 322, 324 that projects outwardly at an angle from its respective arm 318, 320. The resilient tabs 322, 324 are positioned to engage in sliding engagement along portions of the cord 294 that pass through the channels 302, 304. As shown in FIG. 47D, the one tab 322 will allow the cord 294 to slide across the tab in a direction from right to left as shown in the drawing figure, but will prevent the reverse sliding movement of the cord. The other tab 324 will allow sliding movement of the cord 294 across the tab 324 in a left to right direction as shown in FIG. 47D, but will prevent the reverse movement of the length of cord 294.

[0155] FIGS. 48A-48D show a variant embodiment of the one-way locking mechanism 300. As shown in FIG. 48A, the length of cord is passed through the locking mechanism 328 in much the same manner as the earlier-described locking mechanism 300. However, the second channel 330 of the locking mechanism 328 of FIG. 48A has a block 332 with a hole 334 positioned along the channel. An inclined tooth 336 is positioned in the block hole 334. The portion of the cord length 338 that extends through the locking mechanism channel 330 also extends through the block hole 334. A spring 340 in the locking mechanism 328 biases the block 332 and the tooth 336 toward the portion of cord 338 extending through the locking mechanism channel 330. Due to the inclination of the tooth 336, with the spring 340 biasing the tooth 336 into engagement with the cord portion 338, the cord portion 338 can slide over the tooth 336 as it is moved in a left to right direction as shown in FIG. 48C, but is prevented from moving in the opposite direction. Pressing the block 332 into the locking mechanism 328 against the bias of the spring 340 disengages the tooth 336 from the cord portion 338 and permits the cord portion to move in either direction through the locking mechanism 328.

[0156] FIGS. 49A and 49B show a further embodiment of a cord locking mechanism 344 that is similar to that of FIG. 48A. A cross-section of a channel 346 extending through the locking mechanism 344 is shown in FIG. 49A. The channel 346 is formed with pairs of ridges 348, 350 on opposite sides of the channel. A wave form spring 352 is positioned in the channel 346. The spring 352 has grooves 354 formed through peaks formed in the wave form spring. The portion of the cord 356 passing through the locking mechanism channel 346 also passes through the grooves 354 in the wave form spring 352. A button hole 358 is provided in the top of the cord locking mechanism 344 and a release button 360 is positioned in the hole. When the release button 360 is pressed in the hole 358, it engages with the wave form spring 352 and compresses the spring to the position shown in FIG. 49A. In this position of the spring 352 the cord 356 is free

to move in opposite directions through the locking mechanism 344. When the button 360 is released, the spring 352 moves upwardly from its position shown in FIG. 49A and portions of the spring 362 engage with the cord portion 356 extending through the lock mechanism channel 346 and hold the cord portion against the ridges 348 at the top of the channel 346. This locks the cord portion 356 in the locking mechanism 344.

[0157] FIGS. 50A and 50B show a further embodiment of a one-way cord locking mechanism. The mechanism includes a housing 364 having a hole 366 extending through the housing that is defined by a cone-shaped interior surface 368. A pair of lock members 370,372 are positioned in the housing hole 366. Each of the lock members 370, 372 have exterior surfaces 374,376 that when the locking members are positioned together, define a truncated cone shape that fits within the coneshaped interior surface 368 of the housing 364. The opposing interior surfaces 378, 380 of the lock members 370, 372 are formed with mating peaks and valleys. As shown in FIG. 50B, a spring 382 biases the two lock members 370, 372 into the cone-shaped interior surface 368 of the housing 364, thereby causing the lock member interior surfaces 378, 380 to move toward each other. A portion of a cord length 384 extending through the opposing interior surfaces 378, 380 of the lock members 370, 372 is prevented from moving in the upward direction as shown in FIG. 50B due to the bias of the spring 382. However, when the cord portion 384 is moved in the opposite downward direction as shown in FIG. 50B, the movement of the cord portion 384 causes the lock members 370, 372 to compress the spring 382. This allows the lock member interior surfaces 378, 380 to move away from each other and release the portion of the cord 384 for movement through the lock mechanism.

[0158] FIGS. 51A-51E show one method of inserting the apparatus of the invention into the tubular insertion device 86 described earlier. As shown in these drawing figures, a length of suture 386 is looped around the apparatus and is then pulled through the interior of the insertion device 86. The first 14 and second 22 cord segments are folded flat against each other and the additional cord segment 38 is folded over parallel with the first cord segment 14 and second cord segment 22. The apparatus is then pulled by the suture loop 386 into the interior of the insertion device 86 to the position shown in FIG. 51 E.

[0159] FIGS. 52A and 52B show a further embodiment of an insertion device 390. The insertion device 390 has the configuration of an elongate narrow rod with a pair of opposed grooves 392, 394 extending up one side of the rod from a distal end 396 of the rod. A third groove 398 is formed in a side of the rod toward a proximal end of the rod. The third groove 398 is positioned between the opposed pair of grooves 392, 394. According to the method of using the insertion device 390, the first cord segment 14 and second cord segment 22 of the apparatus 12 are positioned in the opposed pair of grooves 392, 394 that extend from the insertion device distal end 396. The additional cord segment 38 of the apparatus 12 is positioned in the third groove 398 in the side of the rod. With the cords of the apparatus held in these grooves, the insertion device 390 is then inserted through a cannula 44 to insert the apparatus 12 into the abdominal cavity.

[0160] FIG. 53 shows a representation of a further embodiment of the insertion device 402 that is similar in

construction to the previously-described embodiment of the insertion device 390. The insertion device 402 of FIG. 53 is also comprised of a pair of opposed grooves 404, 406 that receive the first 14 and second 22 cord segments of the apparatus 12, and a third groove 408 that receives the additional cord segment 38 of the apparatus.

[0161] FIG. 54 shows a still further embodiment of an insertion device 410. The insertion device 410 has a rod-shaped length with a hollow distal end. The rod distal end is comprised of a first half 412 and a second half 414 that are connected together by a living hinge assembly 416. According to the method of using the insertion device 410 of FIG. 54, the apparatus 12 is positioned in the interior of the first half 412 with the first cord segment 14 and second cord segment 22 extending parallel to each other, and the third cord segment 38 folded over the first cord segment 14 and second cord segment 22. The second half 414 of the insertion device is then folded over the hinge assembly 416 and snapped closed to prepare the insertion device 410 for insertion of the apparatus 12.

[0162] FIGS. 55A-55C show a mesh apparatus 420 that is designed to be used as a part of the apparatus of the invention. The mesh apparatus 420 is basically comprised of a generally rectangular or trapezoidal-shaped panel of surgical mesh 422 with a pair of axially aligned tubes 424 at one side and a pair of axially aligned tubes 426 at the opposite side. As shown in FIG. 55B, the mesh apparatus 420 can be rolled up around the pairs of tubes 424, 426 to reduce the size of the apparatus for insertion through a cannula and into the abdominal cavity. FIG. 55C shows the mesh apparatus 420 positioned in the abdominal cavity 46 and held in place against the first internal organ 48 by one of the previously-described embodiments of the apparatus. It should be understood that any of the previously described embodiments of the apparatus may be employed according to the method of the invention to hold the surgical mesh 420 in its position as shown in FIG. 55C.

[0163] FIGS. 56A-56C, 57A-57C, 58A-58C and 59A-59C show an embodiment of the apparatus of the invention 500 that employs a surgical tissue connector with a releasable one-way cord lock. The apparatus 500 is basically designed to be attached between body tissue (or the first internal organ) and the abdomen wall with a cord of the apparatus extending across the first internal organ as in previously described embodiments, but also includes a feature for shortening the portion of the cord extending across the first internal organ to thereby cause the portion of the cord to move the first internal organ away from the second internal organ and to hold the first internal organ in the displaced position. Thus, the apparatus 500 enables the use of only one cord to move the first internal organ to a position away from the second internal organ and then hold the first internal organ at the position.

[0164] The apparatus 500 is comprised of a base 502 having a tubular configuration. More specifically the base 502 is formed as a cylindrical housing wall having a hollow interior bore extending entirely through the length of the base housing. A center axis 506 of the interior bore defines mutually perpendicular axially and radial directions relative to the base. The base cylindrical housing 502 has axially opposite first 508 and second 510 ends.

[0165] A first rod 512 and a second rod 514 are secured to the base. As shown in the drawing figures, the first rod 512 extends radially across the base interior bore adjacent the

base second end 508. Opposite ends of the first rod 512 are secured to the base cylindrical housing 502. The second rod 514 extends radially across the base interior bore adjacent the base second end 510. Opposite ends of the second rod are secured to the base cylindrical housing 502.

[0166] A first tissue connector 516 extends from the base 502 at the base first end 508. In the example shown in the drawings, the tissue connector 516 has a hook 518 formed at one end and a ring 520 formed at the opposite end. The first rod 512 extends through the ring 520 and thereby connects the tissue connector 516 to the base 502. The hook 518 is employed in connecting the apparatus 500 to body tissue. The tissue connector shown in the drawing figures is only one example of a known type of tissue connector that could be employed with the apparatus 500. Any other type of known tissue connector could replace the tissue connector 516 shown in the drawing figures. Additionally, the first tissue connector could be an integral extension of the base.

[0167] A flexible cord 522 having a length with opposite first 524 and second 526 ends is attached to the base 502 at the base second end 510. An intermediate portion 528 of the cord is wrapped around the second rod 514 thereby attaching the cord 522 to the base 502. A first portion or first percentage 530 of the cord length extends from the intermediate portion 528 and from the base second end 510 to the cord first end 524. A second portion or second percentage 532 of the cord length extends from the intermediate portion 528 and from the base second end 510 to the cord second end 526.

[0168] The cord intermediate portion 528 is wrapped around the second rod 514 by being tied in a Munter hitch or Italian hitch knot 534 around the second rod 514. In FIG. 56C the Munter hitch knot 534 is shown on a first radial side of the second rod 514. When the knot 534 is maintained in this position, the first cord portion 530 can be pulled from the knot 534 increasing the length of the cord first portion 530 (or increasing the first percentage of the overall cord length) while decreasing the length of the cord second portion 532 (or decreasing the second percentage of the overall cord length). The cord second portion 532 is braked by the knot 534 with the knot in the first position shown in FIG. 56C and the cord second portion cannot be pulled from the knot to increase its length. In FIG. 57C the Munter hitch knot 534 is shown positioned on a second radial side of the second rod 514, which is on an opposite side of the second rod 514 from the first radial side. When the knot 534 is maintained in this position, the second cord position 532 can be pulled from the knot increasing the length of the cord second portion 532 (or increasing the second percentage of the cord overall length) while decreasing the length of the cord first portion 530 (or decreasing the first percentage of the cord overall length). The cord first portion 530 is braked by the knot 534 with the knot in the second position shown in FIG. 57C and the cord first portion cannot be pulled from the knot to increase its length. The Munter hitch knot 534 is a continuously sliding knot. When the knot 534 is free to move between its first position on the first radial side of the second rod 514 shown in FIG. 56C and its second position on the second radial side of the second rod 514 shown in FIG. 57C, pulling on the cord first portion 530 will cause the knot 534 to move to the first radial side of the rod 512 shown in FIG. 56C. Further pulling on the cord first portion 530 will cause the length of the cord first portion to increase, while the length of the cord second portion 532 decreases.

The cord intermediate portion 528 wrapped around the second rod 514 in the Munter hitch knot 534 is continuously wrapped around the rod as the cord first portion is pulled. Pulling on the cord second portion 532 will cause the Munter hitch knot 534 to move across the second rod 514 to the second radial side of the rod as shown in FIG. 57C. Continuing to pull on the cord second portion 532 will cause the length of the cord second portion 532 to increase while the length of the cord first portion decreases. The cord intermediate portion 528 wrapped around the second rod 514 in the Munter hitch knot 534 is continuously wrapped around the second rod 514 as the cord second portion 532 is pulled.

[0169] A second tissue connector 540 is provided on the cord second end 526. The second tissue connector 540 can be any known type of tissue connector used to attach to body tissue and is therefore shown only schematically in the drawing figures. A percentage of the cord length (the second percentage) extends between the first tissue connector and the second tissue connector. The percentage of the cord length extending between the first and second tissue connectors is intra-abdominally adjustable to increase the percentage of the cord length and to decrease the percentage of the cord length.

[0170] The apparatus 500 also includes a releasable one-way cord lock 542. The lock 542 has a cylindrical exterior surface and engages in sliding engagement with the interior surface of the base cylindrical housing 502. The lock 542 moves in axially reciprocating movements through the base interior bore between a first position of the lock shown in FIG. 56C and a second position of the lock shown in FIG. 57C. A half cylinder protrusion 544 is formed on the end of the lock adjacent the Munter hitch knot 534. As seen in the drawing figures, the protrusion 544 is positioned on the second radial side of the second rod 514. Axial slots 546 are formed in the opposite sides of the base cylindrical housing 502 and a pin 548 extends radially through the lock 542 with opposite ends of the pin engaging in sliding engagement in the axial slots 546 of the base 502. The ends of the pin 548 extending into the axial slots 546 allow the lock 542 to axially reciprocate through the interior bore of the base but prevent the lock 532 from rotating around the interior bore of the base. This maintains the lock protrusion 544 on the second radial side of the second rod 514.

[0171] An actuator 550 is mounted on the base 502 and is operatively connected to the reversible one-way cord lock 542. The actuator 550 is formed as a cylindrical sleeve that surrounds the base cylindrical housing 502. The opposite ends of the lock pin 548 project beyond the axial slots 546 in the base cylindrical housing 502 and are secured in opposite sides of the actuator 550. This operatively connects the actuator with the lock 542. The actuator 550 is mounted on the cylindrical housing of the base 502 for axially reciprocating movements between first and second positions of the actuator relative to the base. Moving the actuator 550 to its first position relative to the base 502 moves the one-way cord lock 542 to its first position relative to the base shown in FIG. 56C. Moving the actuator 550 to its second position relative to the base 502 moves the cord lock 542 to its second position relative to the base shown in FIG. 58C.

[0172] A biasing device urges the one-way cord lock 542 to its first position shown in FIG. 56C. In the embodiment of the apparatus shown in the drawing figures the biasing device 552 is a coil spring. As shown in FIG. 56C, with the

knot 534 positioned on the first radial side of the second rod 514, the spring 552 biases the lock 542 toward the knot 534 until the lock protrusion 544 engages against the cord intermediate portion 528 adjacent the knot 534. In this position of the protrusion 544 the protrusion prevents the knot 534 from moving around the second rod 514 to the second radial side of the rod. With the knot 534 maintained on the first radial side of the second rod 514 by the lock protrusion 544, exerting a pulling force on the cord first portion 530 will increase the length of the cord first portion while decreasing the length of the cord second portion 532. With the knot 534 maintained on the first radial side of the second rod 514 by the lock protrusion 544, exerting a pulling force on the cord second portion 532 will not result in increasing the length of the cord second portion 532 and decreasing the length of the cord first portion 530. The friction of the knot 534 held in the position shown in FIG. 56C will resist the cord second portion 532 from being pulled from the base second end 510.

[0173] With the actuator 550 being moved to its second position and in turn the one-way cord lock 542 being moved to its second position shown in FIG. 57C, the knot 534 is free to move between the first radial side of the second rod 514 as shown in FIG. 56C and the second radial side of the second rod 514 as shown in FIG. 57C. With the lock protrusion 544 moved away from the knot, exerting a pulling force on the cord second portion 532 will cause the knot 534 to move from its position on the first radial side of the second rod 514 shown in FIG. 56C to its position on the second radial side of the second rod 514 shown in FIG. 57C. In this position of the knot, the pulling force exerted on the cord second portion 532 will result in the length of the cord second portion 532 increasing while the length of the cord first portion 530 decreases. When the actuator 550 is released and the spring 552 biases the one-way cord lock 542 back toward its first position, exerting a pulling force on the cord first portion 530 will cause the knot 532 to move from its position on the second radial side of the second rod 514 shown in FIG. 57C to its position on the first radial side of the second rod 514 shown in FIG. 56C. The biasing force of the spring 552 is not sufficient to hold the knot 534 positioned on the first radial side of the second rod 514 as shown in FIG. 56C, again exerting a pulling force on the cord first portion 530 will result in increasing the length of the cord first portion while decreasing the length of the cord second portion 532. Again, the friction of the knot 534 held at the position on the first radial side of the second rod 514 shown in FIG. 56C will resist the cord second portion 532 from being pulled from the base housing second end 510.

[0174] FIGS. 60A-60C, 61A-61C, 62A-62C and 63A-63C show a variant embodiment of the tissue connector apparatus with a releasable one-way cord lock just described. In this further embodiment of the apparatus 554, many of the component parts of the apparatus 554 are the same as those of the previously described apparatus 500. Therefore, these component parts will not be described again. The reference numbers used to identify the component parts in this further embodiment are the same as those used in identifying the component parts of the previous embodiment of the apparatus 500. These component parts include the base cylindrical wall housing 502, the first rod 512, the second rod 514,

the first tissue connector **516**, the second tissue connector **540**, the cord **552**, the Munter hitch knot **534** and the biasing device or coil spring **552**.

[0175] The construction of the further embodiment of the apparatus **554** differs from that of the previous embodiment basically in the construction of the releasable one-way cord lock **556**. The lock **556** has a lock protrusion **544** that functions in the same manner as the previous embodiment. However, the cylindrical configuration of the lock **556** extends beyond the base cylindrical housing first end **508** to an annual flange or rim **558** on an opposite end of the lock from the protrusion **554**. This rim **558** functions as the actuator of the lock **556**. The rim **558** surrounds a hollow center bore **560**. The bore extends from the rim down into the lock **556** and ends short of the lock protrusion **544**. A pair of axially extending slots **562** are formed in the opposite sides of the lock **556** and communicate the interior bore **560** with the exterior of the lock **556**. The first rod **508** extends through the pair of slots **562**. The engagement of the first rod **512** through the slots **562** enables the lock **556** to reciprocate between its first and second positions relative to the base **502**, but prevents the lock **556** from rotating relative to the base. This maintains the protrusion **544** on the second radial side of the second rod **514**.

[0176] The first tissue connector **516** is connected to the first rod **512** just as in the previous embodiment. The first tissue connector **515** extends from the first rod **512** to the hook **518** of the connector.

[0177] The biasing device in the form of the coil spring **522** is positioned in the interior bore **560** of the lock **556**. The spring **522** is positioned between the first tissue connector ring **520** and the lock **556** and exerts a biasing force on the lock pushing the lock toward its first position relative to the base **502**.

[0178] The releasable one-way cord lock **556** of the apparatus **554** functions in the same manner as the previously described apparatus in maintaining the Munter hitch knot **534** on the first radial side of the second rod **514** when the lock is in its first position relative to the base, and allowing the knot **534** to move to the second side of the second rod **514** when the lock is moved to its second position on the base.

[0179] Both embodiments of the apparatus have the same method of use. Basically, a portion of the cord is attached to body tissue on an opposite side of the abdominal cavity from the abdominal wall, an additional portion of the cord is attached to the abdominal wall positioning a length or percentage of the cord across the first internal organ, and then the length or percentage of the cord extending across the first organ is decreased thereby causing the decreasing percentage of the cord length to engage across and move the first internal organ away from the second internal organ. This is illustrated schematically in FIG. **64**. As in the previously described embodiments, the apparatus **554** is first manually passed through the abdomen wall **42**, for example through an incision or a cannula **44** in the abdomen wall and is positioned in the abdominal cavity **46** in the area of the first **48** and second **50** internal organs. In the example shown, the first internal organ **48** represented is the human liver and the second internal organ **50** represented is the human stomach.

[0180] The second tissue connector **540** of the apparatus **554** is then manually connected to tissue **52** adjacent to the first internal organ **48** and between the first **48** and second **50**

internal organs. In the example shown in FIG. **65**, the tissue **52** is the crus of the diaphragm. Alternatively, the second tissue connector **540** could be connected to the tissue of the first internal organ **48** itself, as shown in FIG. **66**. The apparatus **554** is then grasped by its actuator **558** and moved toward the abdominal wall **42**. This movement causes the actuator **558** and its associated releasable one-way cord lock to move to their second positions. The movement of the lock allows the knot to move to the second side of the second rod **514** when the cord second portion **532** is pulled in tension. The movement of the knot to the second side of the second rod **514** allows the cord second portion **532** to be pulled from the base second end **510** and increase in length (or increase in percentage) as the apparatus **554** is moved toward the abdominal wall **42**. When at the abdominal wall, the tissue connector **516** of the apparatus **500/554** is then connected to the inner abdominal wall **42**. This positions the cord second portion **532** extending from the second tissue connector **540** across the first internal organ **48** to the first tissue connector **516** attached to the abdominal wall **42**.

[0181] The actuator **558** of the apparatus **554** is then released. This results in the spring of the apparatus moving the releasable one-way cord lock to its first position relative to the base **502**.

[0182] The cord first portion **530** is then grasped and pulled from the base second end **510**. This causes the knot to move to the first side of the second rod **514** and causes the length of the cord first portion **530** to increase (or increase in percentage) while decreasing the length of the cord second portion **532** (or decreasing the percentage of the cord second portion). The decreasing length of the cord second portion **532** is pulled tight across the first internal organ **48**.

[0183] Continuing the pulling force on the cord first portion **530** continues to decrease the length of the cord second portion **532** causing the cord second portion to move the first internal organ **48** toward the position away from the second internal organ **50**. When the first internal organ **58** is in the desired position, the grasping and pulling force on the cord first portion **530** is released. With the pulling force on the cord first portion **530** having moved the knot to the first radial side of the second rod **514**, the lock protrusion prevents the knot from moving back to the second radial side of the second rod **514**. With the knot maintained on the first radial side of the second rod **514**, the length of the cord second portion cannot be increased. Therefore, the cord second portion **532** holds the first internal organ **48** in its position away from the second internal organ **50** as shown in FIG. **67**.

[0184] When it is desired to remove the apparatus **554** from the abdominal cavity the actuator **558** is again grasped and moved toward its second position on the base **502**. This causes the lock to move to its second position and moves the lock protrusion away from the knot. This again allows the knot to move to the second side of the second rod **514** and allows the cord second portion **532** to be pulled from the base second end **510**. This in turn allows the first internal organ **48** to return to its original position relative to the second internal organ **50**. The increased length of the cord second portion **532** enables the first tissue connector **516** and second tissue connector **540** to be removed from their connections to the body tissue.

[0185] FIG. **68** shows a still further embodiment of the apparatus of the invention. The apparatus in FIG. **68** comprises a first tissue connector **572**, a cord **574** and a second

tissue connector **576** that are the same as those of the previously discussed embodiment of the apparatus. In addition, the apparatus of FIG. **68** includes a third tissue connector **578** that is the same as the first tissue connector **572**, and a second length of cord **582** that is the same as the first length of cord **574**. The apparatus of FIG. **68** also includes a fourth tissue connector **584** that is mounted to the portion of the cord **574** extending between the first tissue connector **572** and the second tissue connector **576** for sliding movement of the fourth tissue connector **584** along the length of cord.

[0186] The method of using the apparatus shown in FIG. **68** is similar to that of previously described embodiments. The second tissue connector **576** is connected to body tissue adjacent to the first internal organ or to the first internal organ, and then the first tissue connector **572** is moved intra-abdominally toward the abdominal wall and is connected to the abdominal wall. This causes the first cord **574** to extend across the first internal organ. The third tissue connector **578** is then moved intra-abdominally toward the abdominal wall and is connected to the abdominal wall in a position spaced from the first tissue connector **572**. This causes the second cord **582** to extend across the first internal organ. Shortening first **574** and second **582** cords causes the cords to engage with and move the first internal organ upwardly and away from the second internal organ in a manner similar to that of previously described embodiments.

[0187] In addition to the above, the fourth tissue connector **584** can be used to laterally displace or move the first internal organ in a sideways direction. This is accomplished by grasping the fourth tissue connector **584** with a surgical grasper and then pushing the first internal organ to one side or the other before securing the fourth tissue connector **584** to body tissue. This results in the fourth tissue connector **584** holding the first internal organ in its sideways displaced position.

[0188] As various modifications could be made in the constructions of the apparatus and the methods herein described and illustrated without departing from the scope of the invention, it is intended that all matter contained in the foregoing description or shown in the accompanying drawings shall be interpreted as illustrative rather than limiting. Thus, the breadth and scope of the present invention should not be limited by any of the above-described exemplary embodiments, but should be defined only in accordance with the following claims appended hereto and their equivalents.

We claim:

1. A surgical tissue connector system for moving a first body tissue to a position away from a second internal body tissue and then holding the first internal body tissue in the position, characterized by:

- a first tissue connector that is connectable to body tissue;
 - a second tissue connector that is connectable to body tissue;
 - a base comprising a first end and a second end, and a bore extending within the base;
 - a rod extending through the bore of the base;
 - a lock slidably disposed within the bore of the base;
 - a cord extending from the second tissue connector to the base, said cord characterized by a first portion extending from the rod and out of the base at the second end, a second portion extending from the rod and out of the base at the second end, and an intermediate portion comprising the sliding knot passing over the rod and engaging the rod;
 - an actuator connected to the lock, and operable to move the lock within the bore of the base;
 - wherein, in a first configuration, the knot is disposed on a first side of the bore opposite, relative to the rod, an impinging structure of the lock, and is free to slide in a first direction away from the impinging structure when the cord first portion is pulled, and the knot is prevented from sliding in a second direction toward the impinging structure when the cord second portion is pulled; and
 - wherein, in a second configuration, the knot is disposed on a second side of the bore, on the same side of the bore, relative to the rod, as the impinging structure of the lock, and the knot free to slide in a second direction away from the impinging structure when the cord second portion is pulled, and the knot is inhibited from sliding in the first direction toward the impinging structure when the cord first portion is pulled.
2. The system of claim 1, further comprising:
- a biasing spring operable to apply biasing force to the lock, to bias the lock toward the base second end and thereby urge the impinging structure into contact with the knot.
3. The system of claim 2, wherein the biasing force of the spring is not sufficient to hold the knot on the second side when the cord first portion is pulled in the first direction.
4. The system of claim 2, wherein the knot is prevented from being pulled in the first direction, corresponding to the first side, through the housing, when the sliding knot is locked on the second side of the rod.
5. The system of claim 1, wherein:
- lock has a cylindrical exterior surface and slidably engages an interior surface of the housing.
6. The system of claim 1, wherein:
- the housing is cylindrical, and the actuator comprises a cylindrical sleeve that surrounds the housing.

* * * * *

专利名称(译)	用于腹腔内移动器官的系统		
公开(公告)号	US20170035408A1	公开(公告)日	2017-02-09
申请号	US15/298144	申请日	2016-10-19
申请(专利权)人(译)	弗里霍尔德手术, INC.		
当前申请(专利权)人(译)	弗里霍尔德手术, INC.		
[标]发明人	SCOTT J STEPHEN SMITH JEFFREY		
发明人	SCOTT, J. STEPHEN SMITH, JEFFREY		
IPC分类号	A61B17/02 A61B17/04		
CPC分类号	A61B17/0218 A61B17/0401 A61B17/0466 A61B17/0487 A61B2017/0496 A61B2017/0448 A61B2017/0461 A61B2017/0464 A61B2017/0417 A61B17/0482 A61B17/062 A61B17/0643 A61B17/083 A61B2017/0225 A61B2017/06057 A61B2017/06071 A61B2017/0647		
优先权	14/240928 2014-02-25 US PCT/US2011/001494 2011-08-25 WO		
其他公开文献	US9687218		
外部链接	Espacenet USPTO		

摘要(译)

一种手术组织连接器系统，用于将第一内部身体组织移动到远离第二内部身体组织的位置，然后将第一内部身体组织保持在该位置。组织连接器固定到绳索，使得组织连接器之间的绳索长度可以在腹腔镜工作空间中容易地调节。

