



US 20130317305A1

(19) **United States**

(12) **Patent Application Publication**
Stevenson et al.

(10) **Pub. No.: US 2013/0317305 A1**
(43) **Pub. Date: Nov. 28, 2013**

(54) **REMOVABLE MEDICAL RETRACTOR TIP**

(22) Filed: **Mar. 4, 2013**

(71) Applicant: **COOK MEDICAL TECHNOLOGIES LLC**, Bloomington, IN (US)

Related U.S. Application Data

(60) Provisional application No. 61/651,803, filed on May 25, 2012.

(72) Inventors: **Andrew R.L. Stevenson**, Queensland (AU); **Tiffany Burleigh**, Queensland (AU); **Michael William Ford**, Queensland (AU); **Carolina Gutierrez**, Queensland (AU); **Michael Carl Junger**, Queensland (AU); **James Macnaughtan**, Queensland (AU); **Caitlin Vizcay-Wilson**, Queensland (AU)

Publication Classification

(51) **Int. Cl.**
A61B 17/02 (2006.01)
(52) **U.S. Cl.**
CPC *A61B 17/0218* (2013.01)
USPC **600/204**

(73) Assignee: **Cook Medical Technologies LLC**, Bloomington, IN (US)

(57) **ABSTRACT**

The exemplary embodiments illustrated provide the discovery of systems, methods, and apparatuses of removable tips for use with medical retractors in laparoscopic surgery that provide many benefits, including but not limited to, improving the efficiency and navigation to the target anatomy while maintaining adequate exposure to the target anatomy.

(21) Appl. No.: **13/783,570**

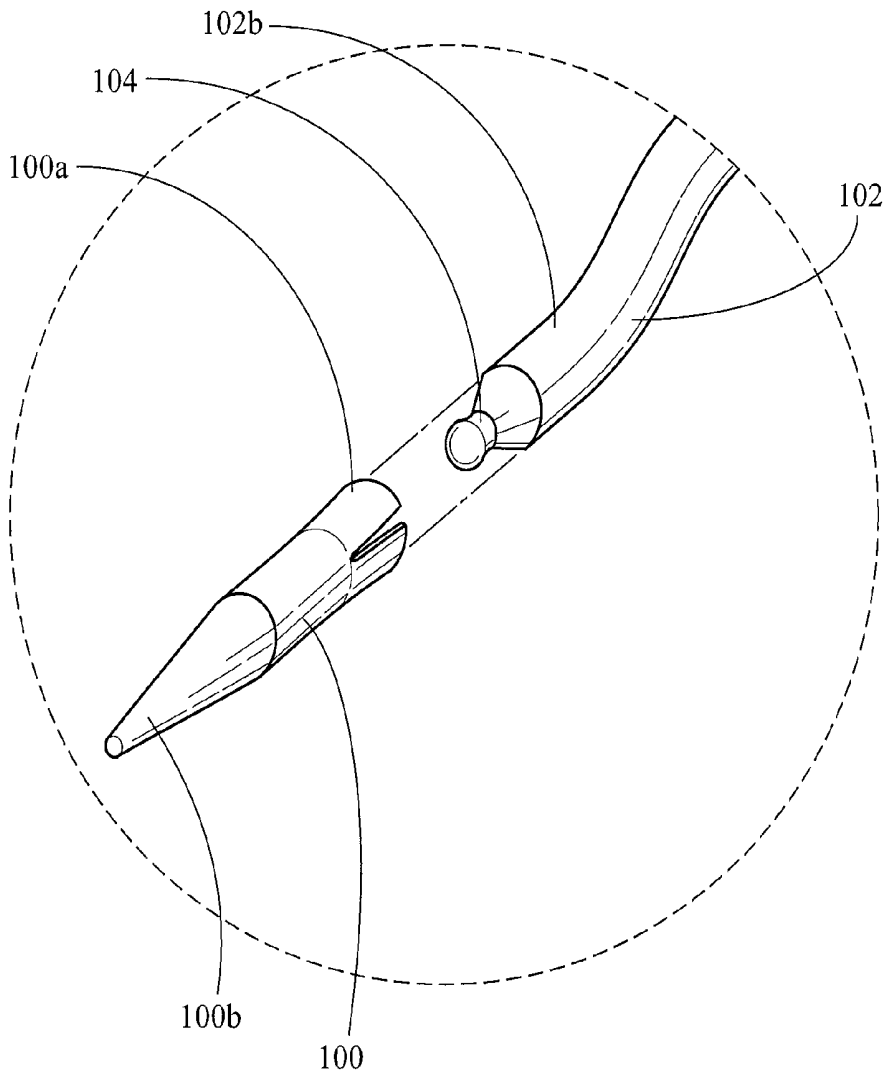

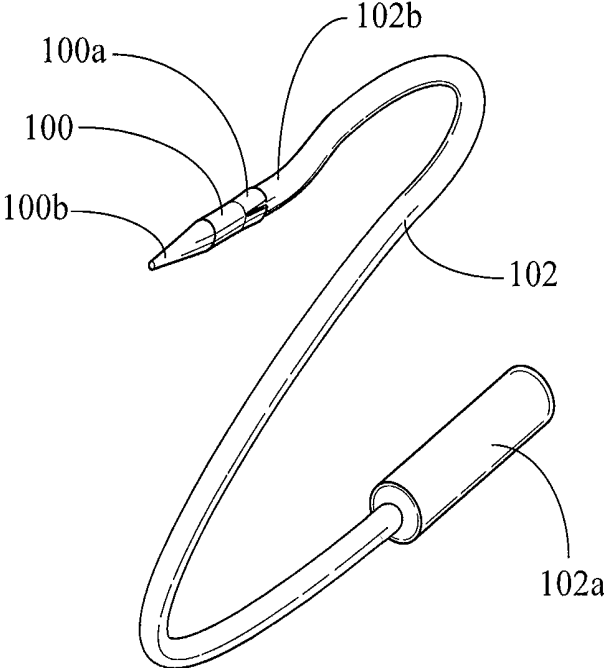

Fig. 1A

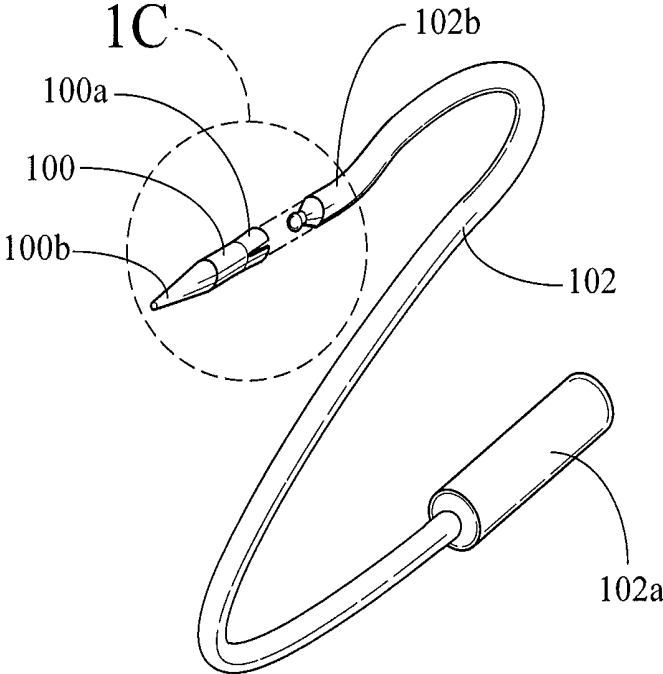

Fig. 1B

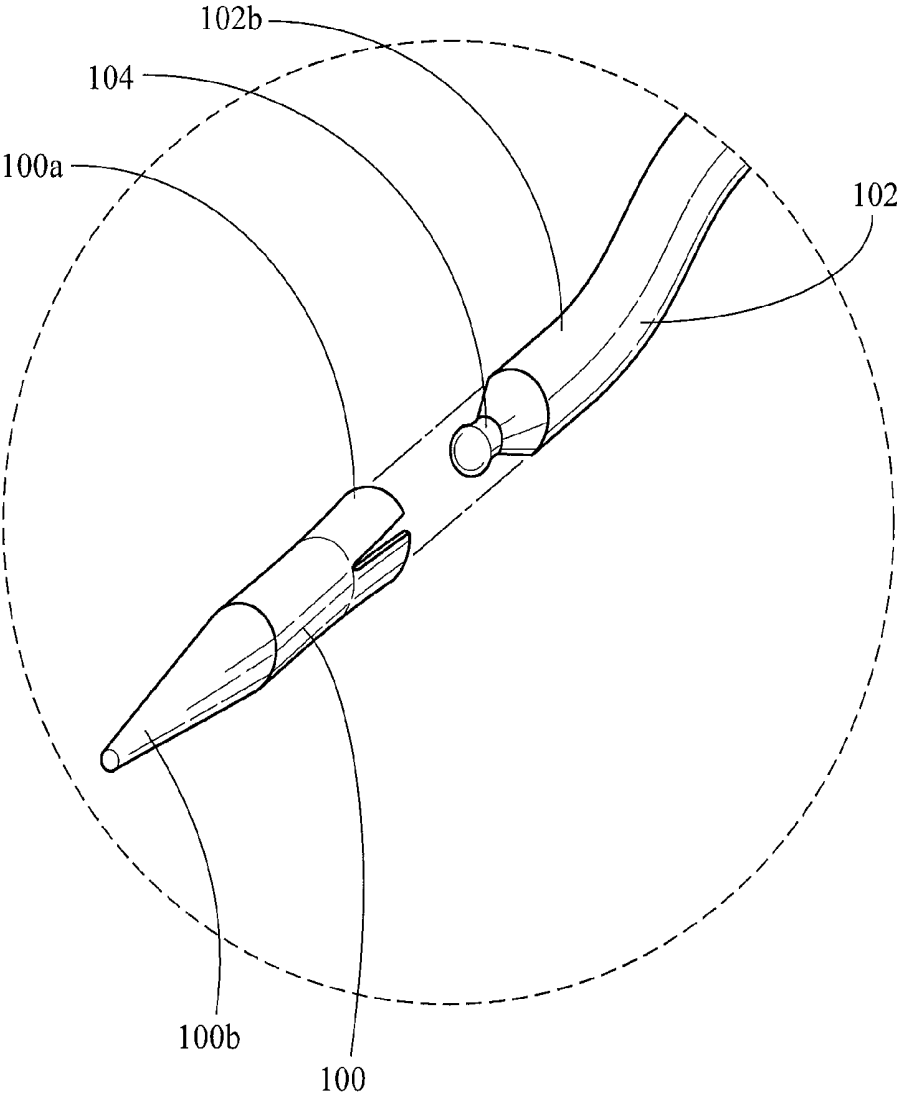

Fig. 1C

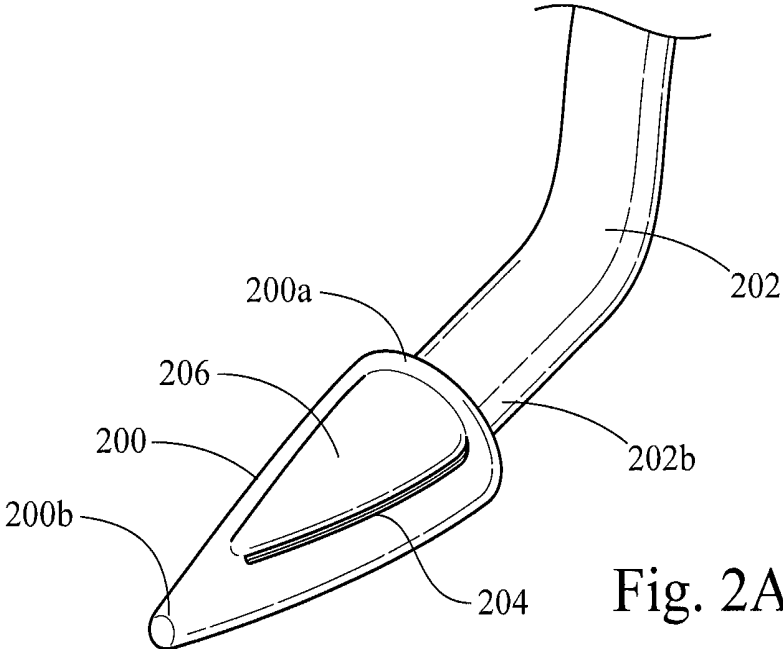

Fig. 2A

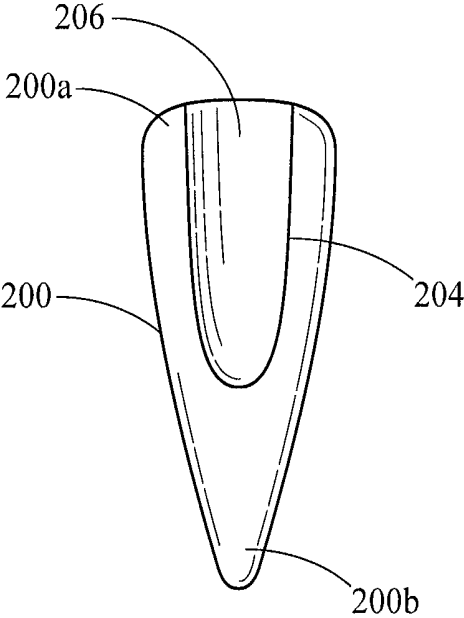
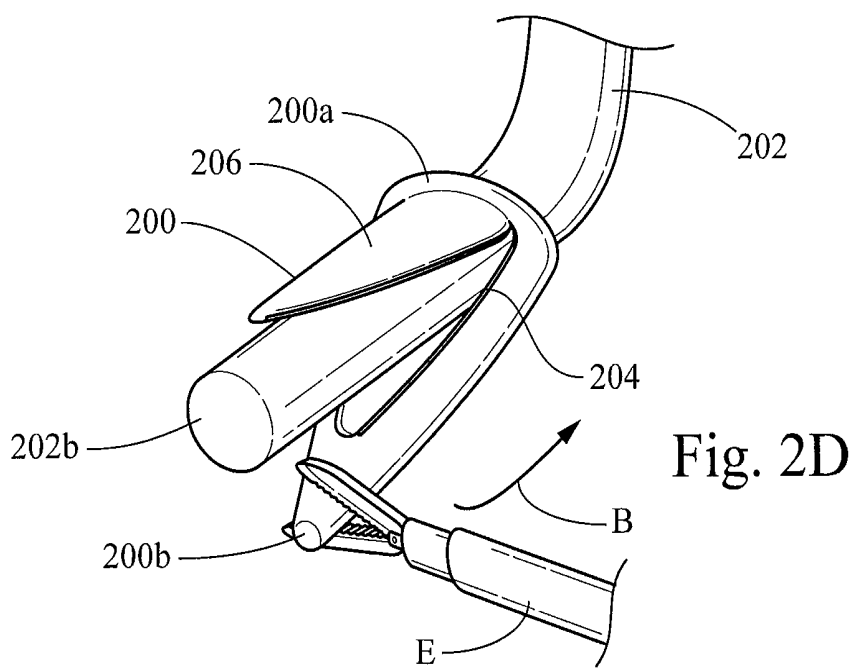
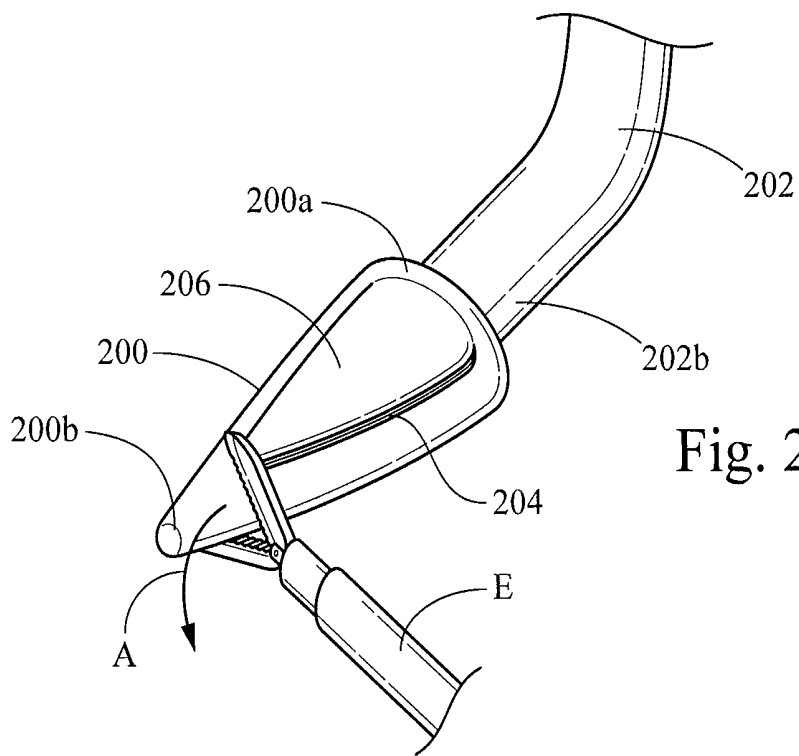

Fig. 2B



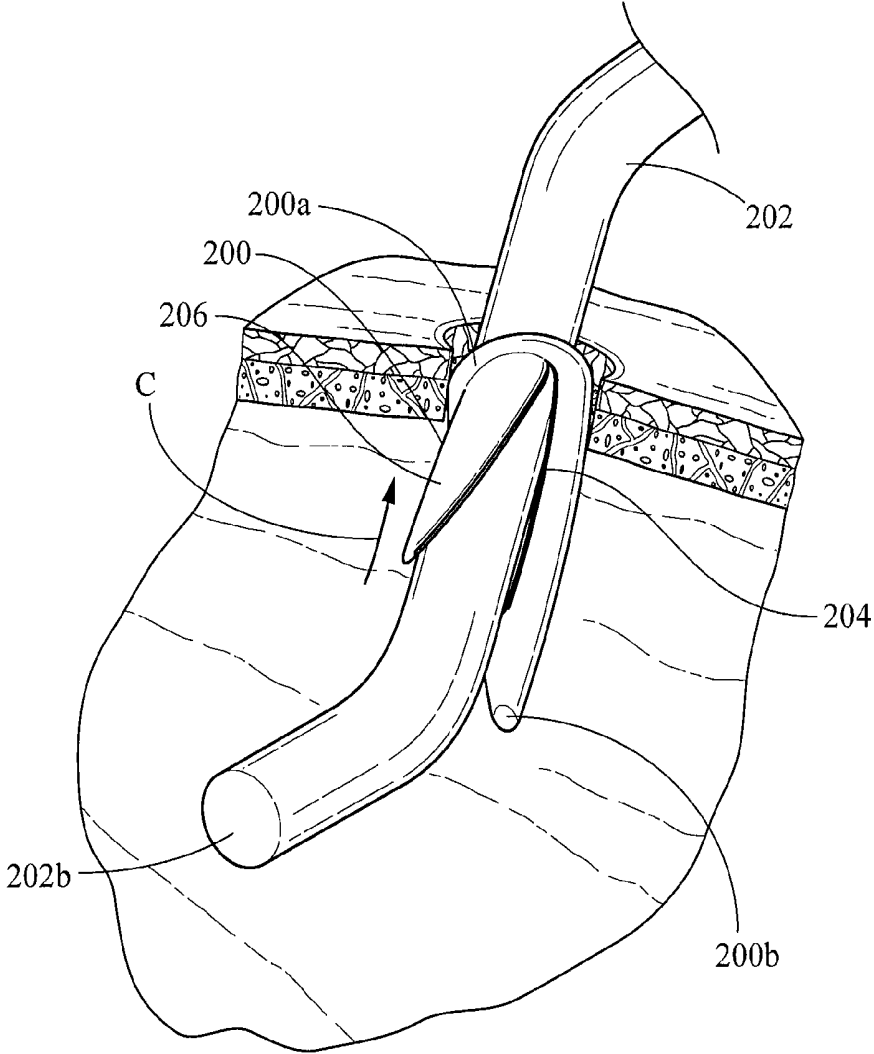

Fig. 2E

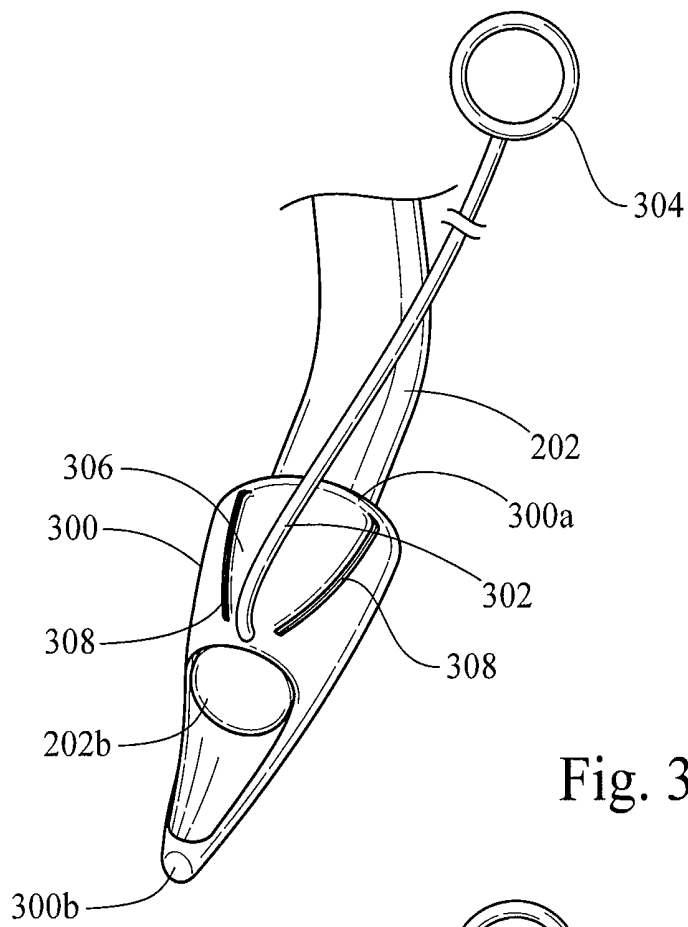

Fig. 3A

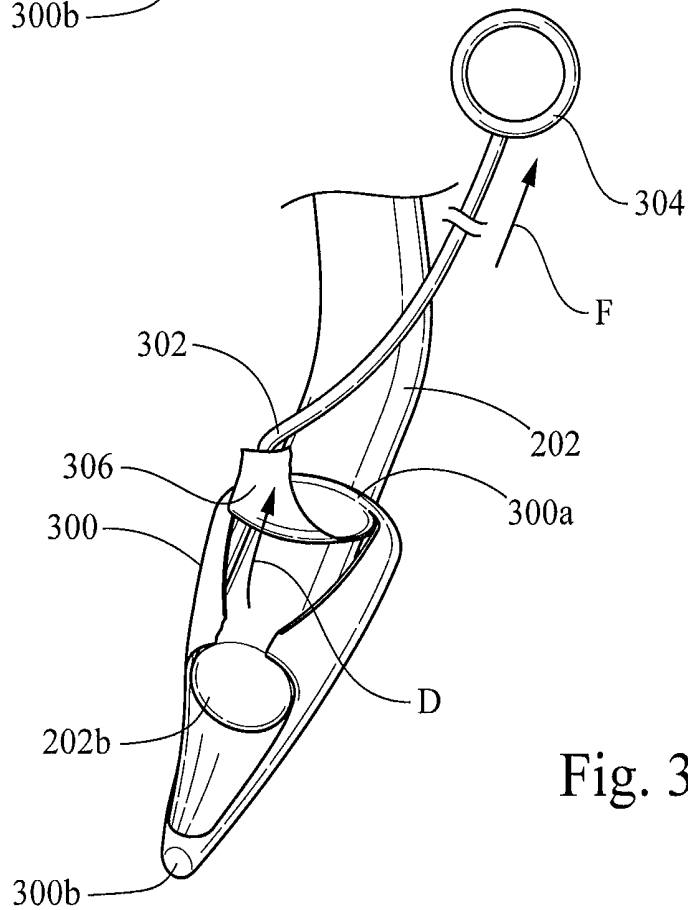
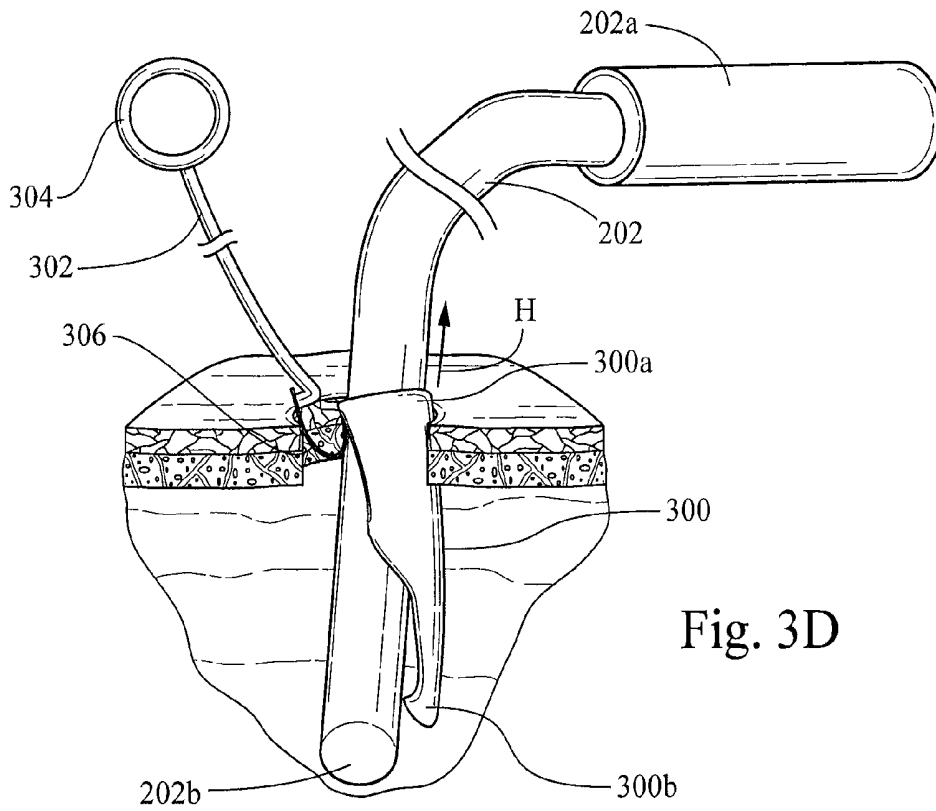
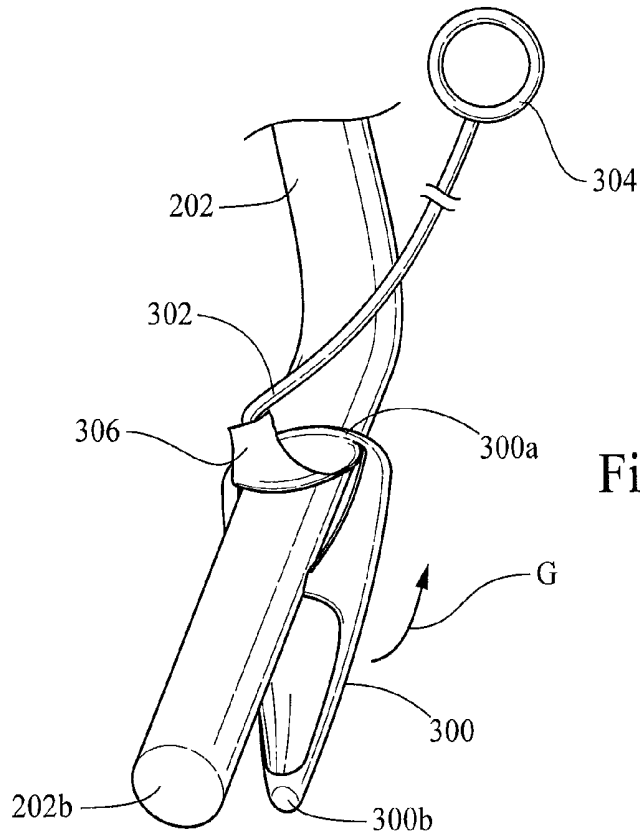
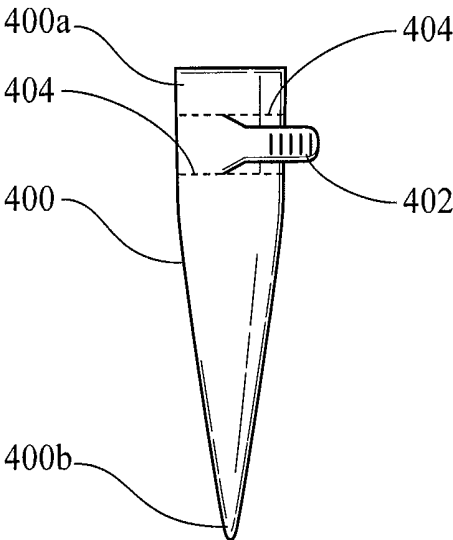
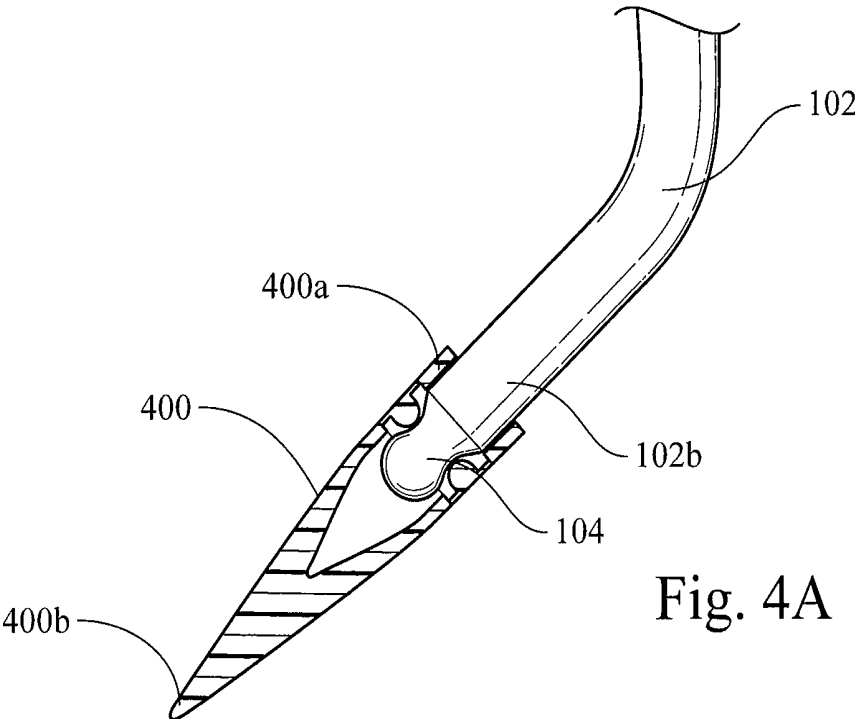

Fig. 3B





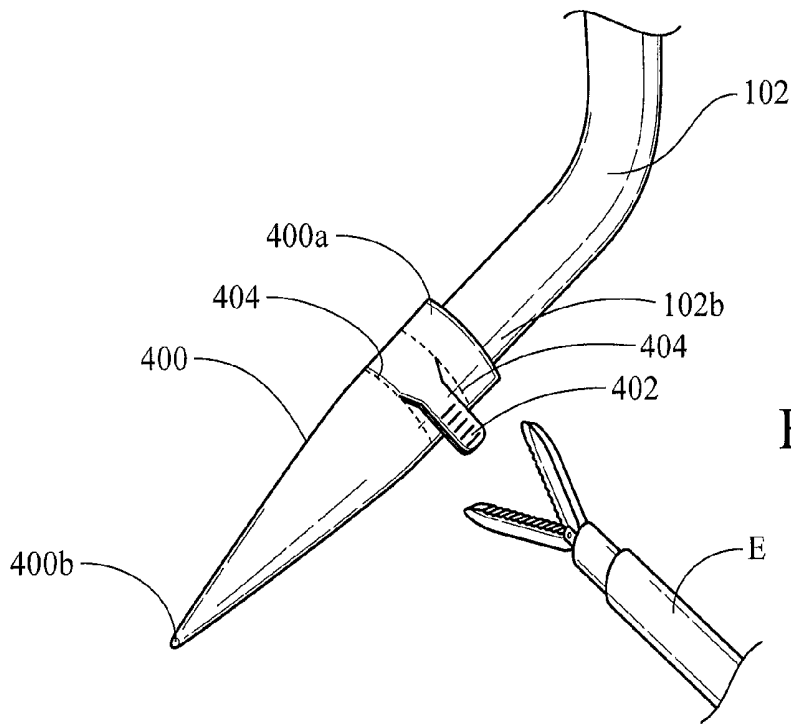

Fig. 4C

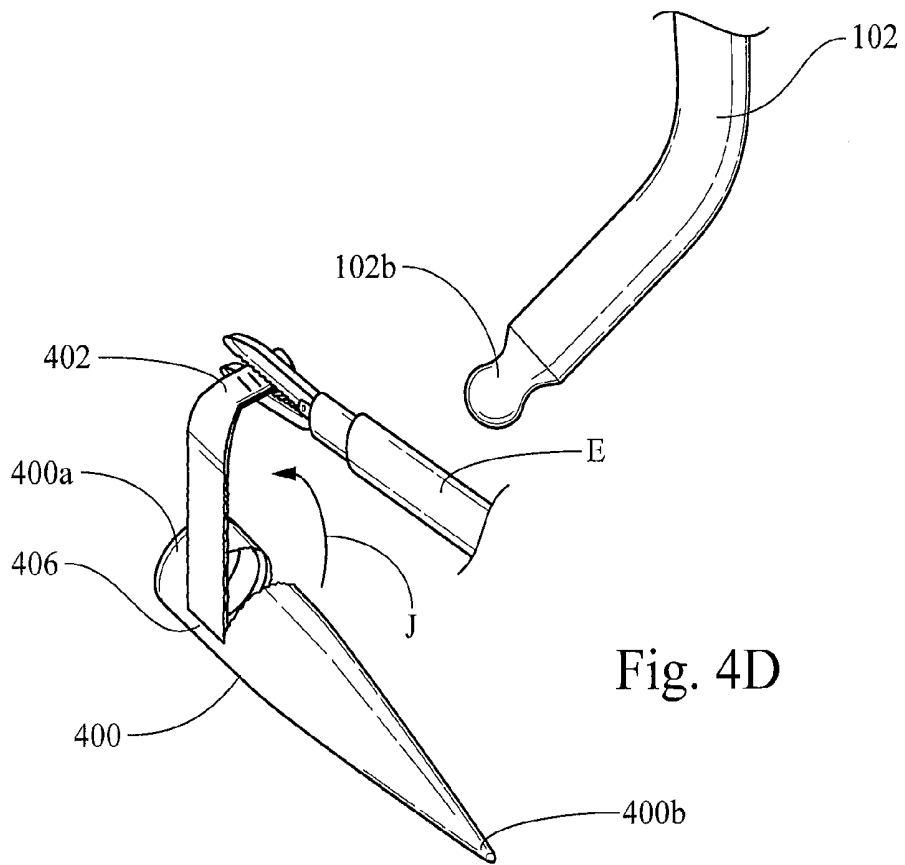
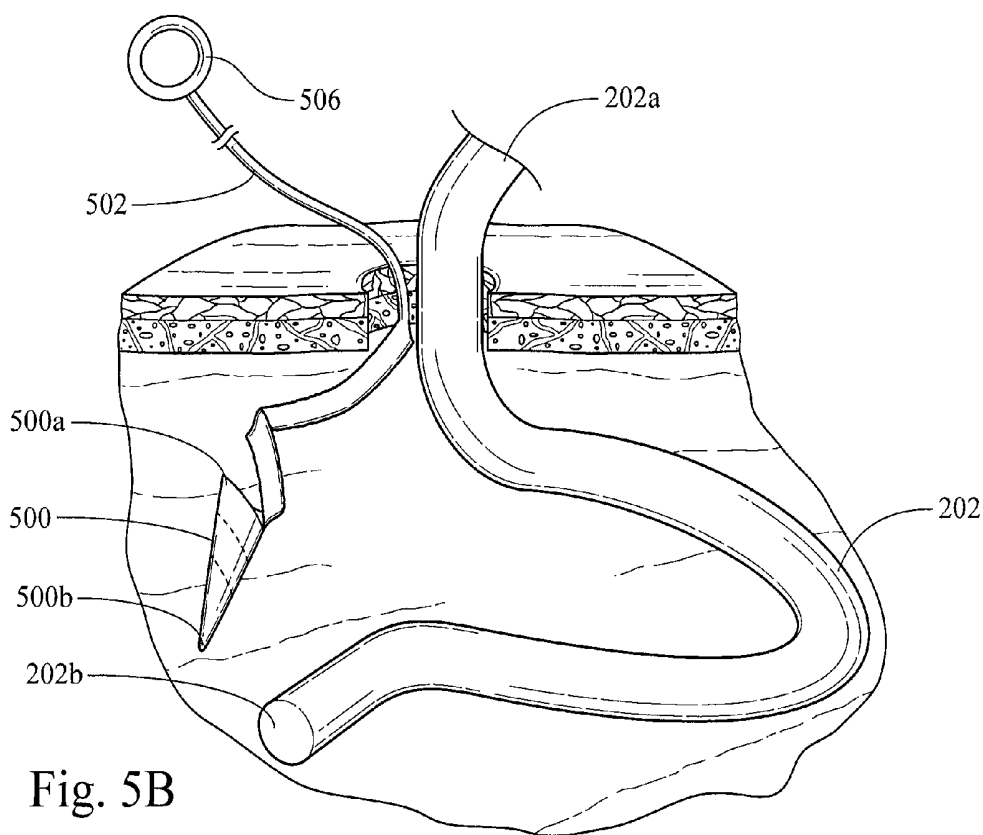
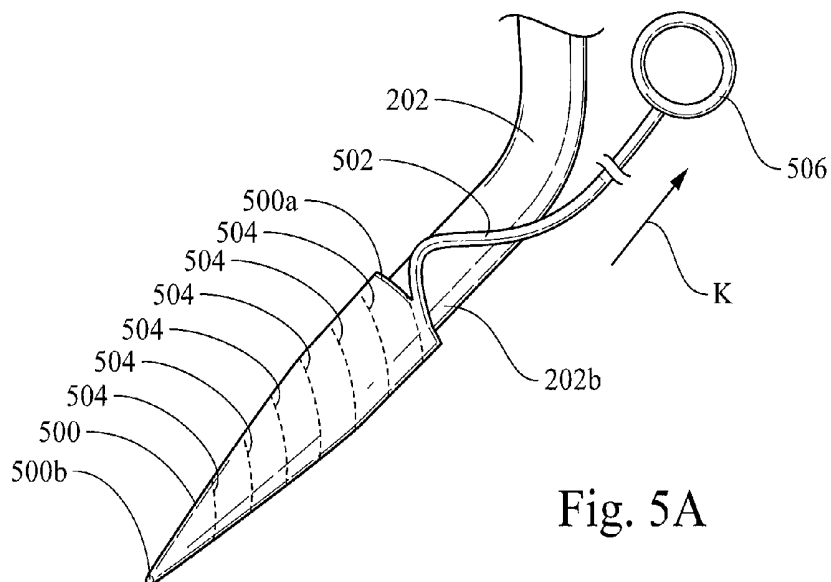
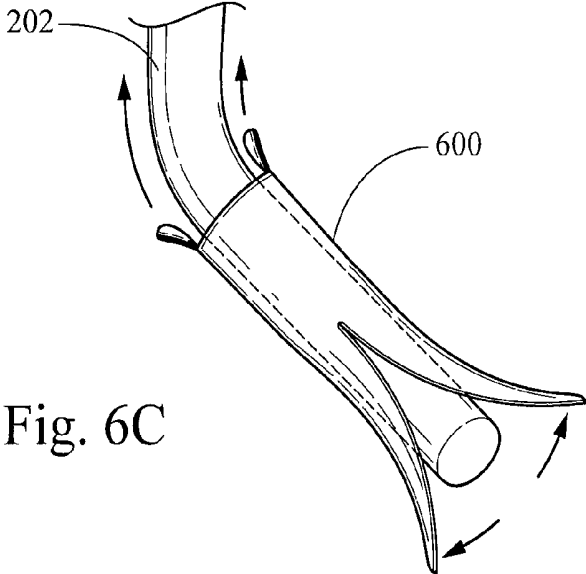
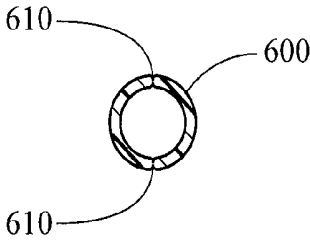
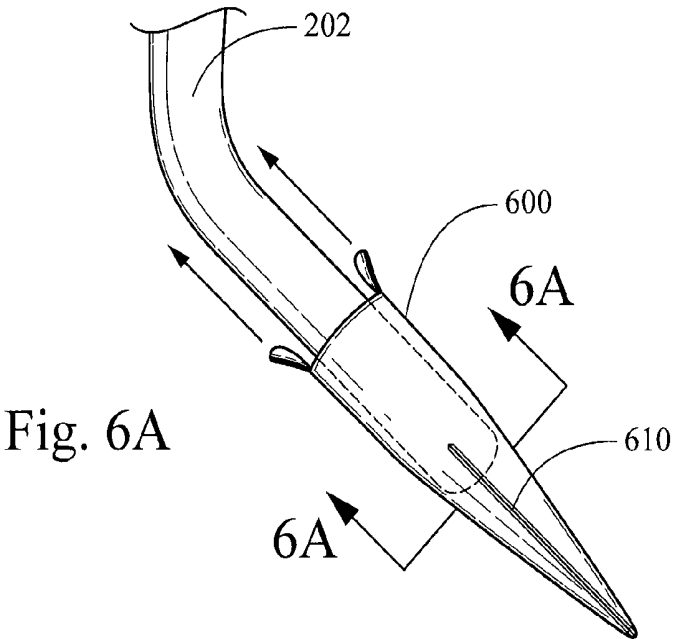

Fig. 4D





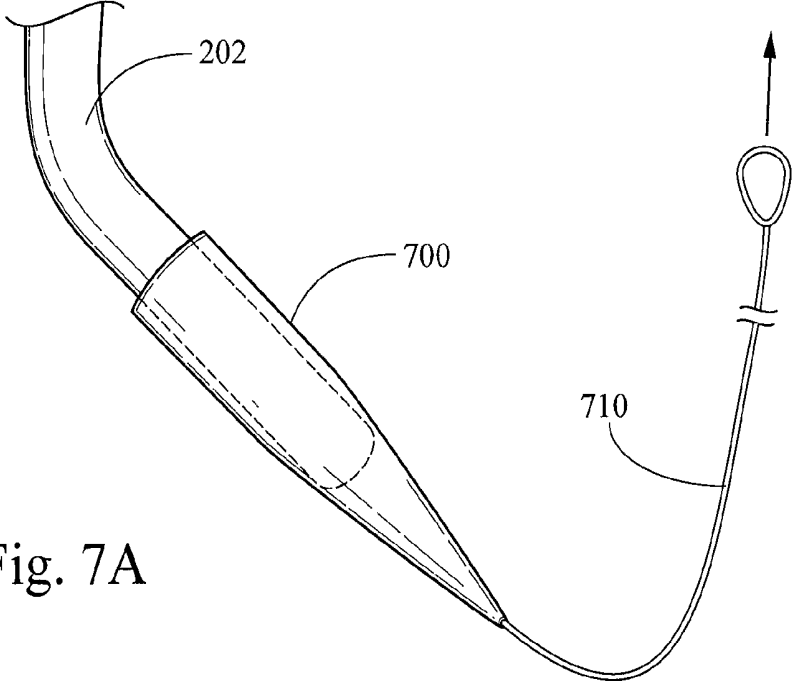

Fig. 7A

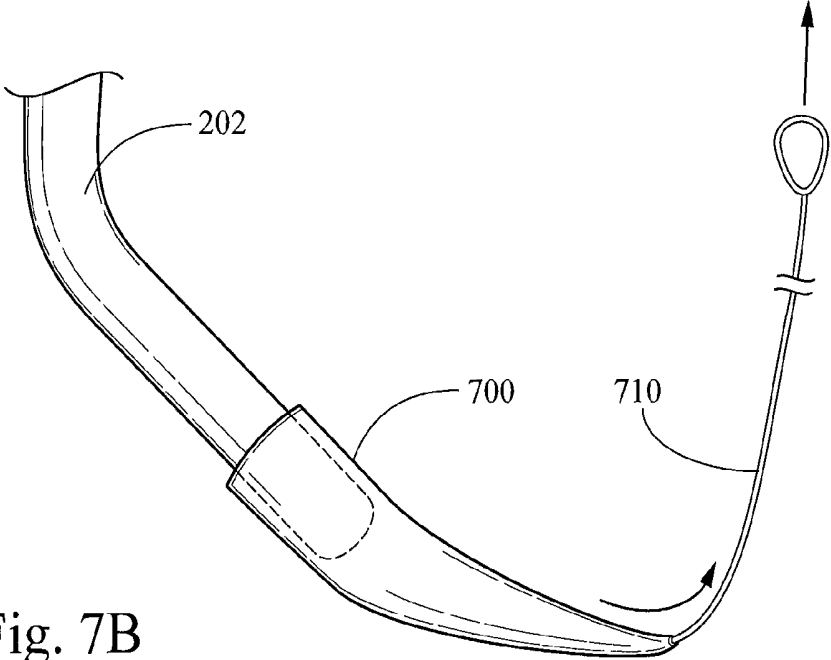

Fig. 7B

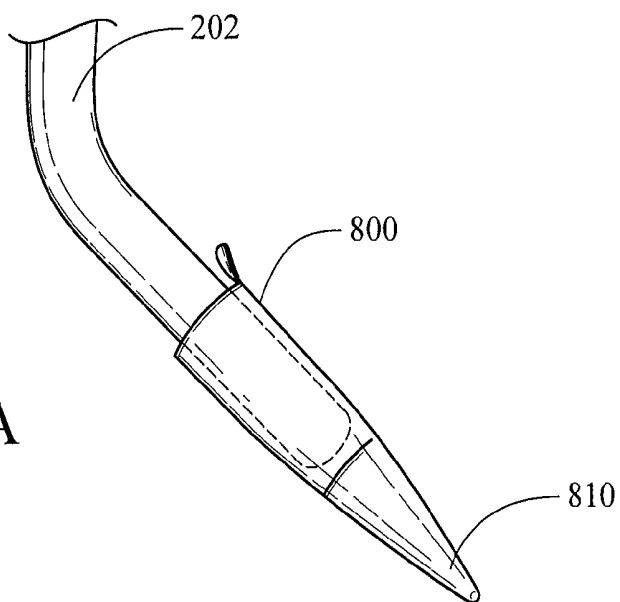

Fig. 8A

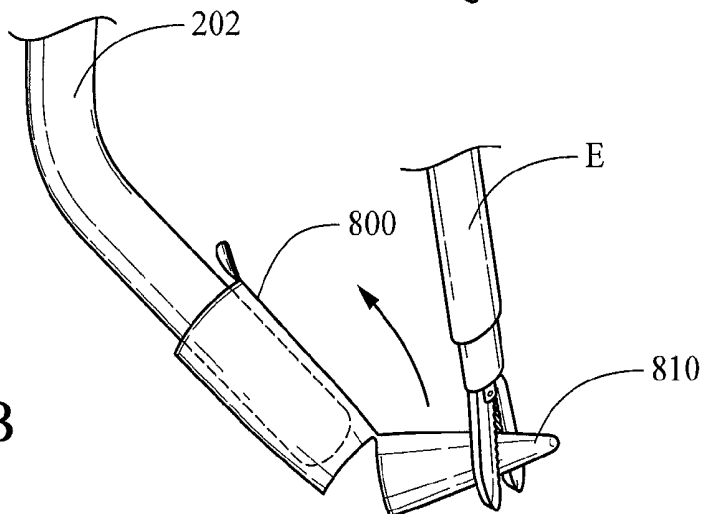

Fig. 8B

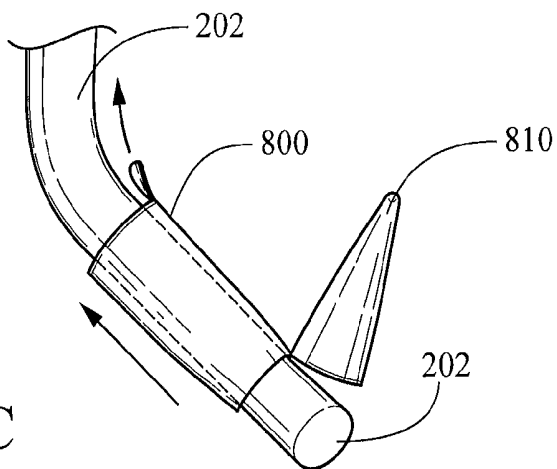
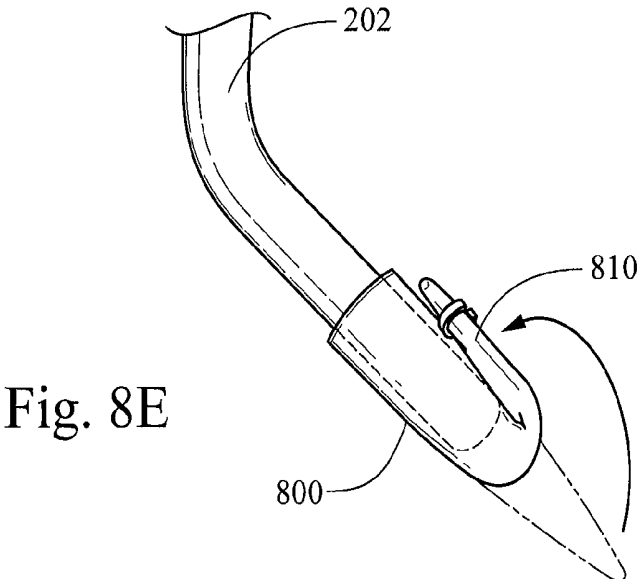
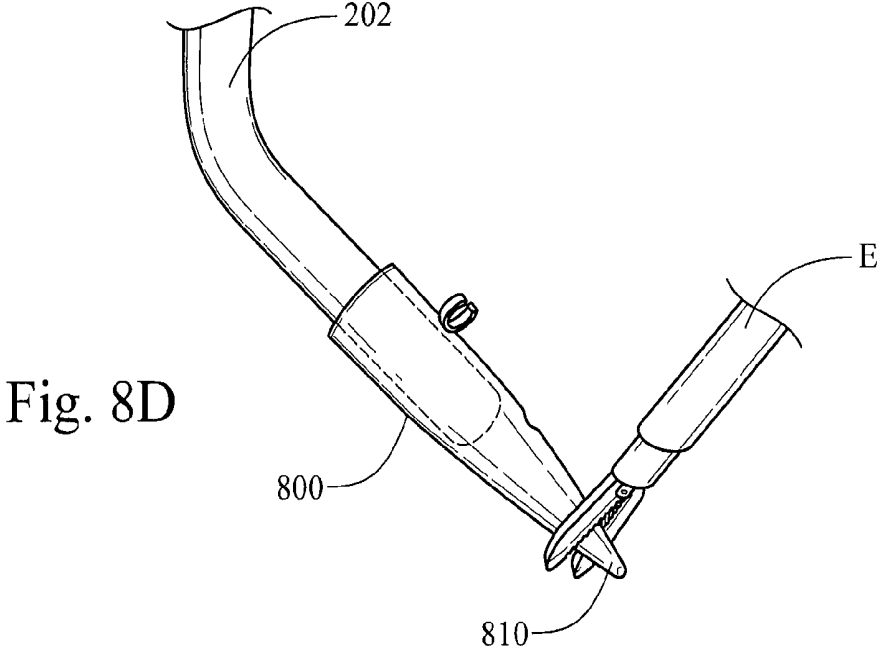

Fig. 8C



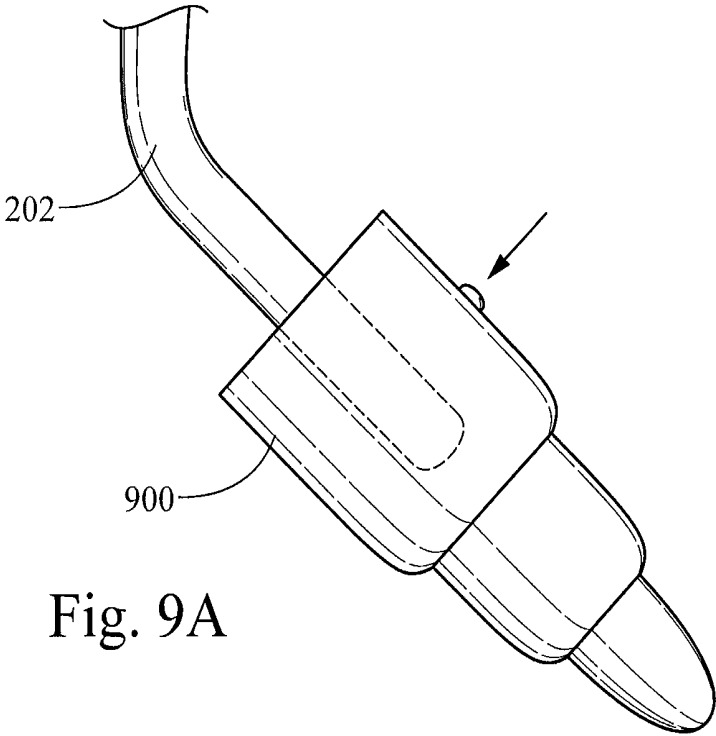

Fig. 9A

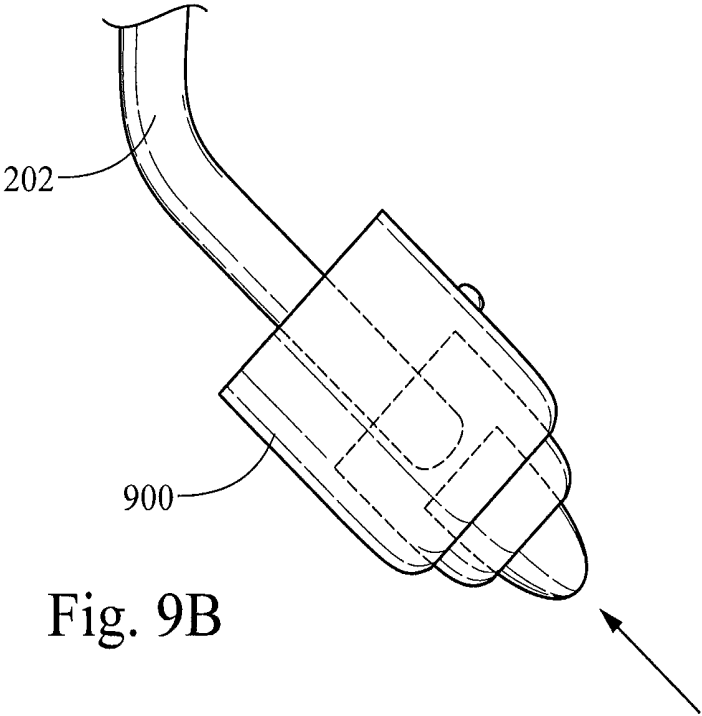

Fig. 9B

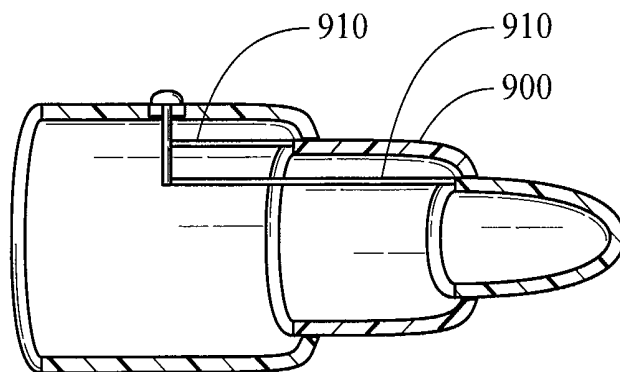

Fig. 9C

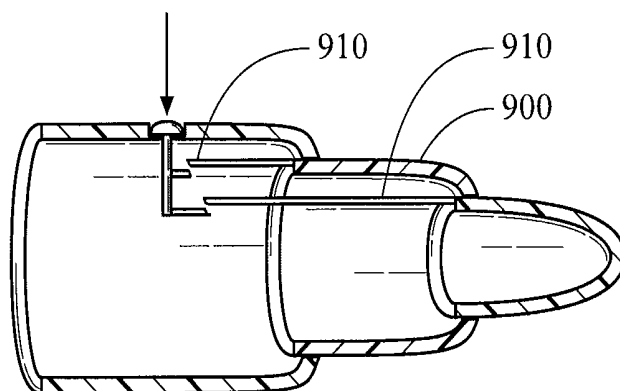

Fig. 9D

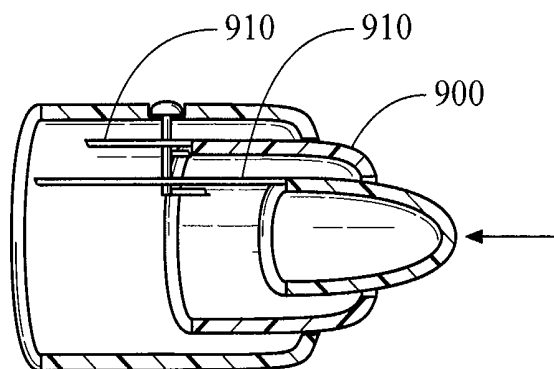

Fig. 9E

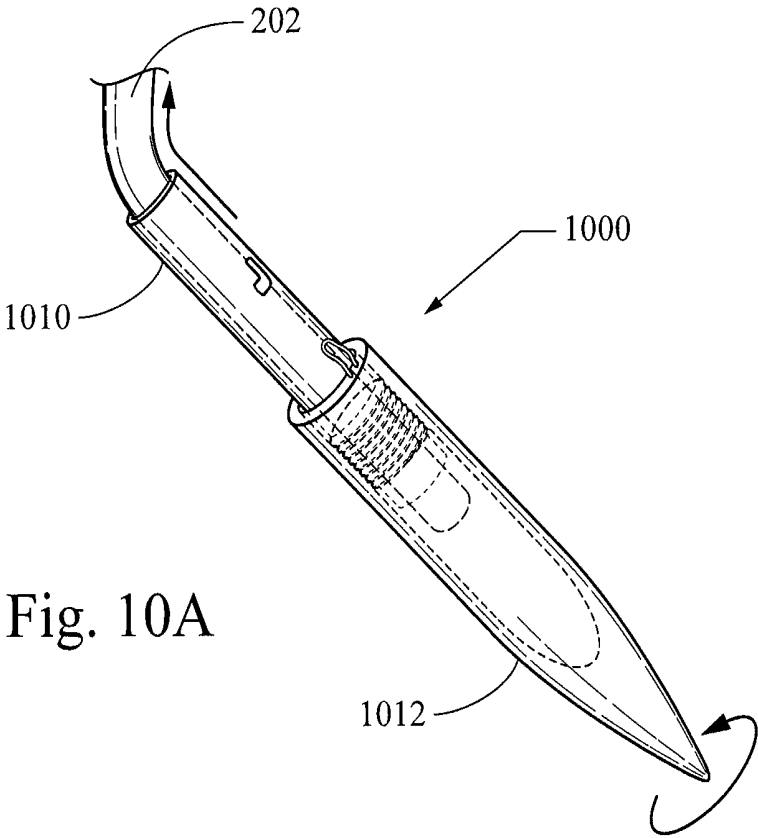

Fig. 10A

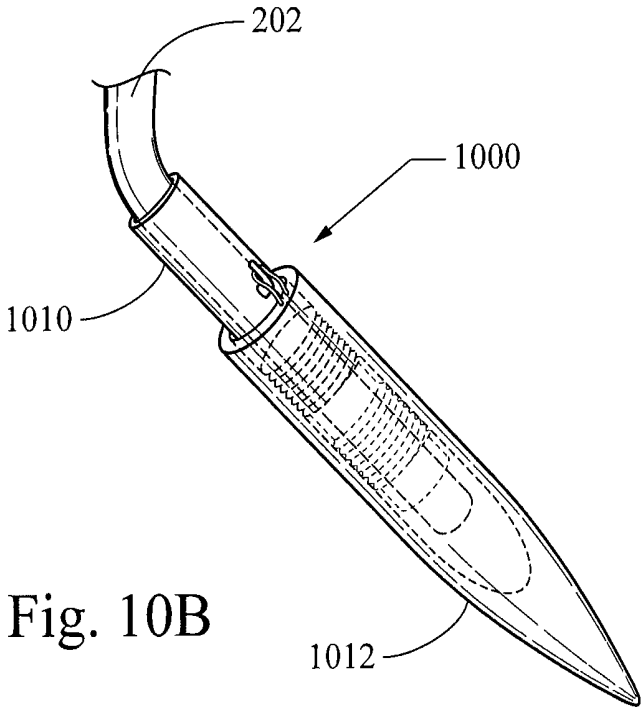

Fig. 10B

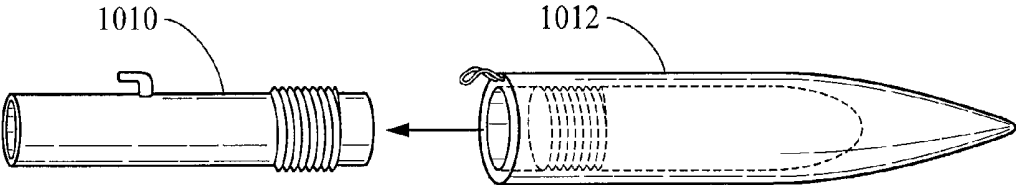

Fig. 10C

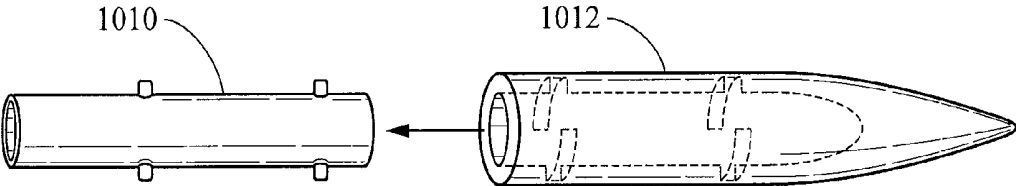

Fig. 10D

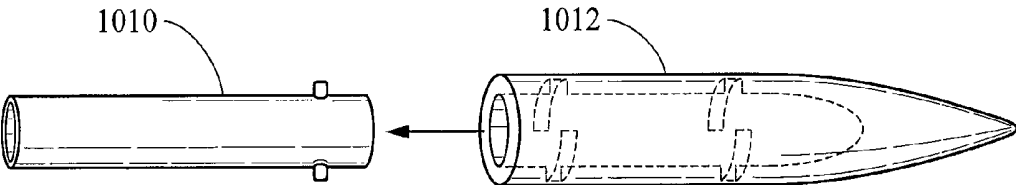

Fig. 10E

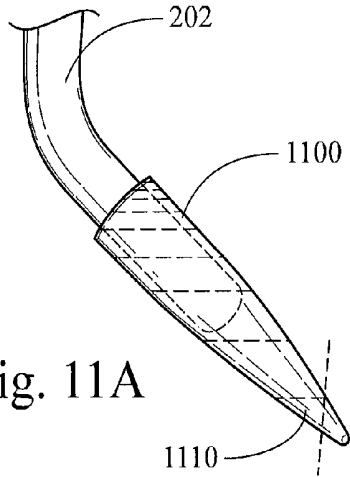

Fig. 11A

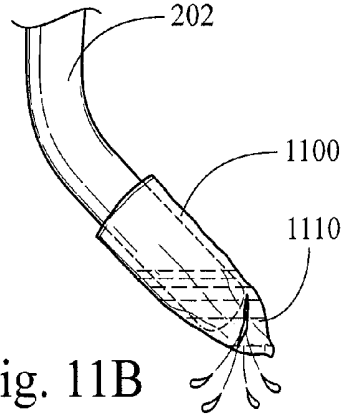

Fig. 11B

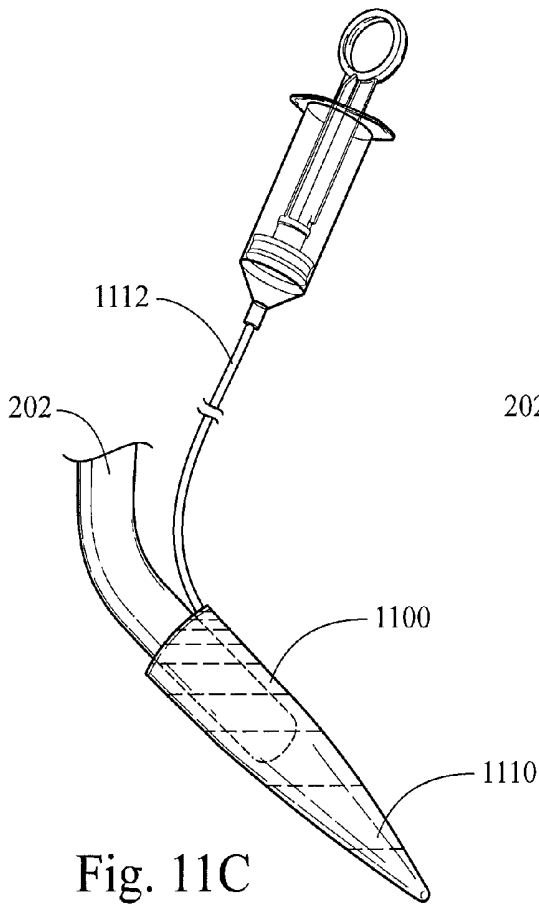

Fig. 11C

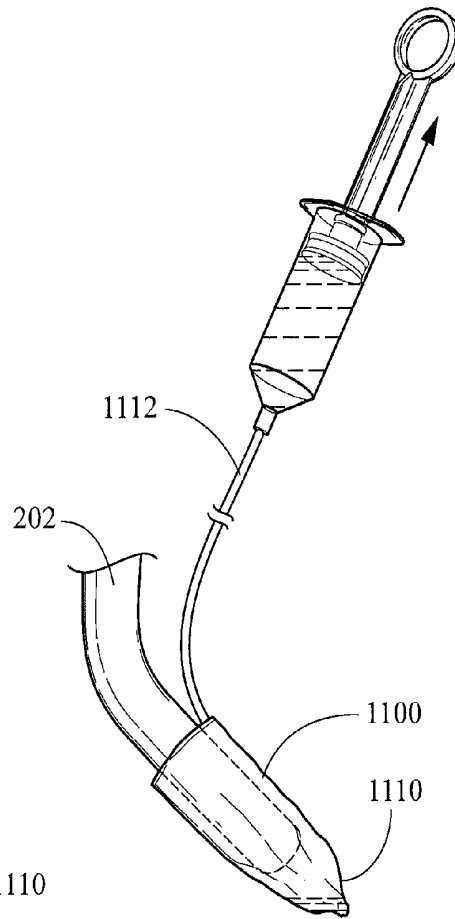

Fig. 11D

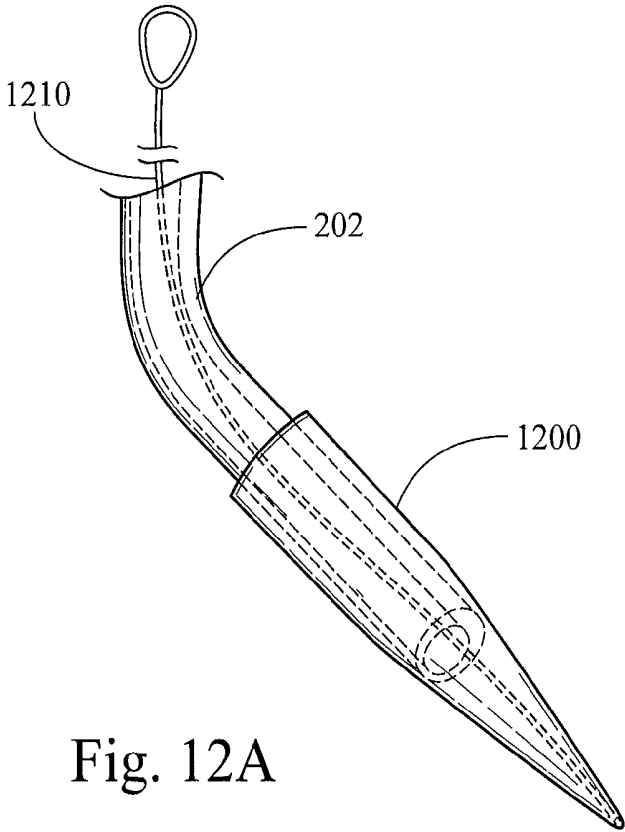

Fig. 12A

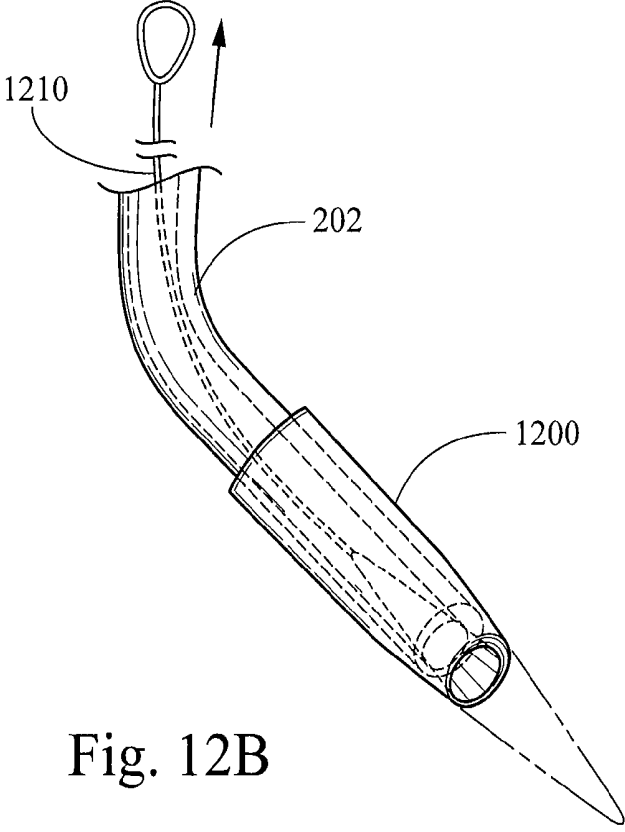
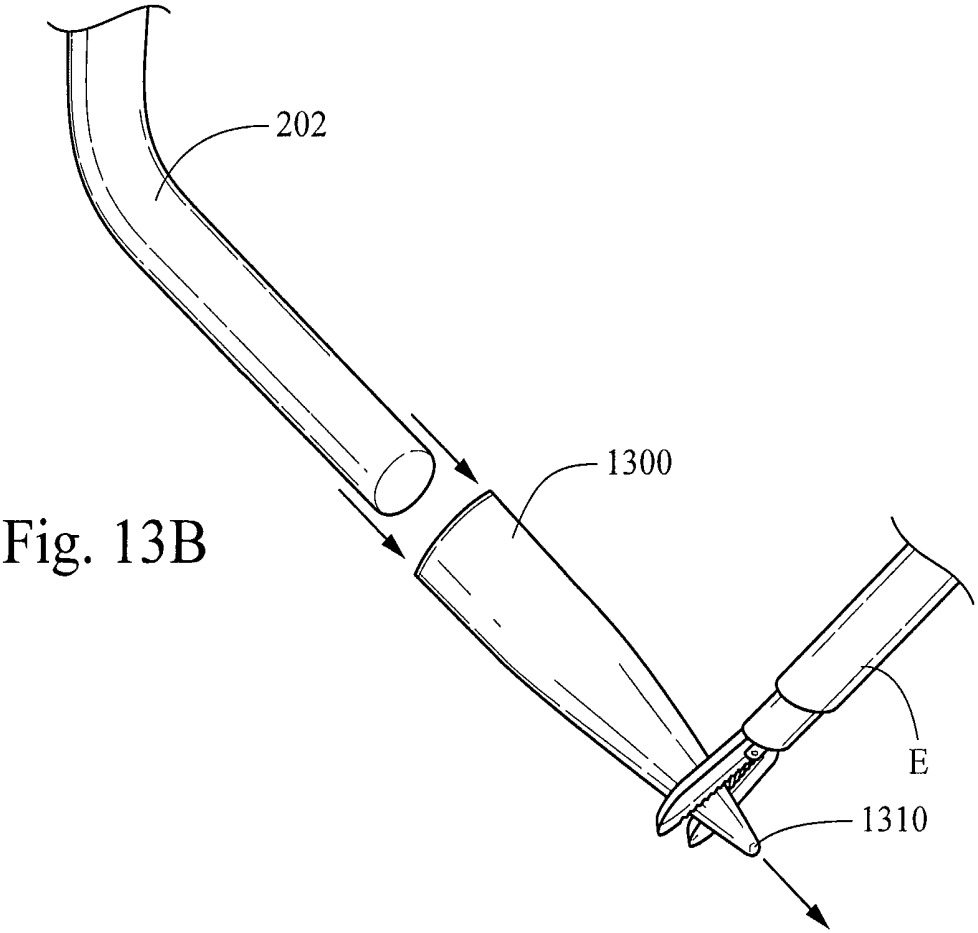
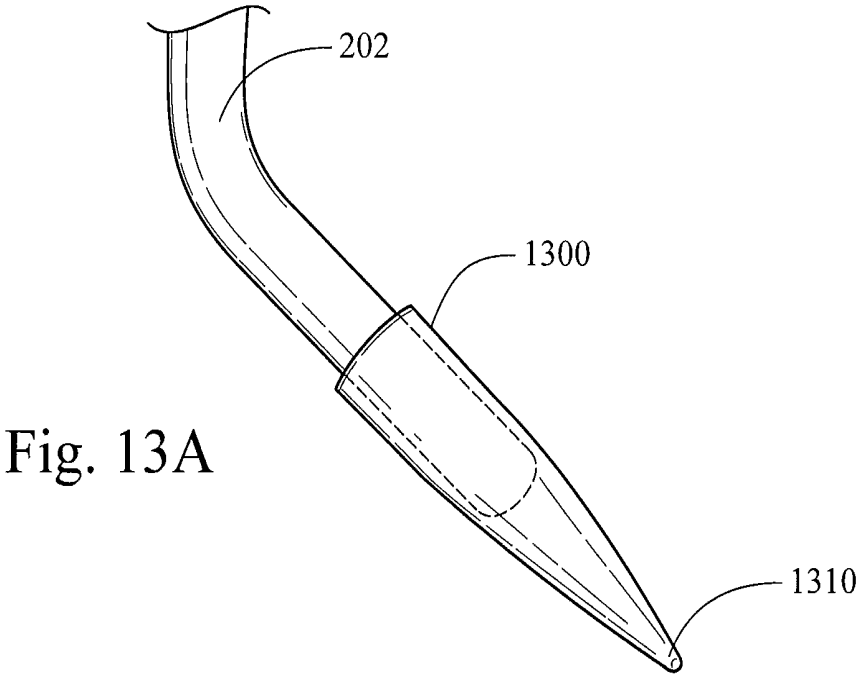

Fig. 12B



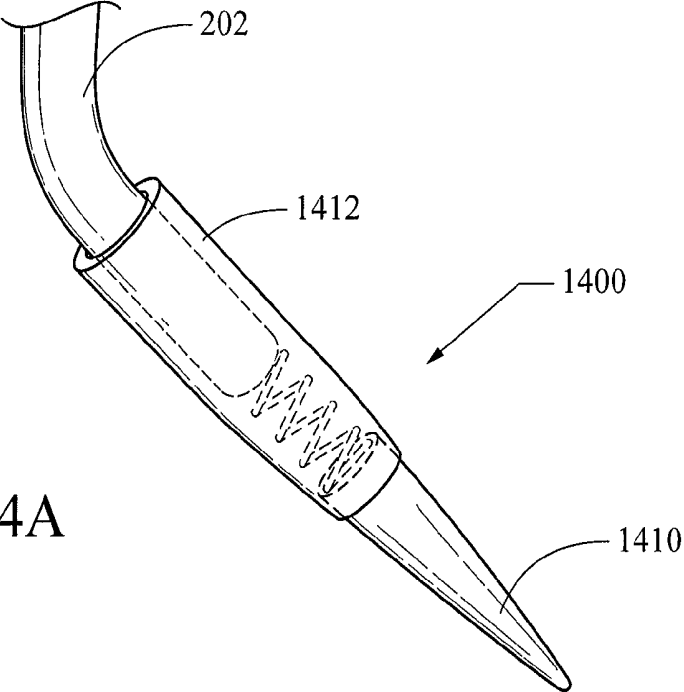

Fig. 14A

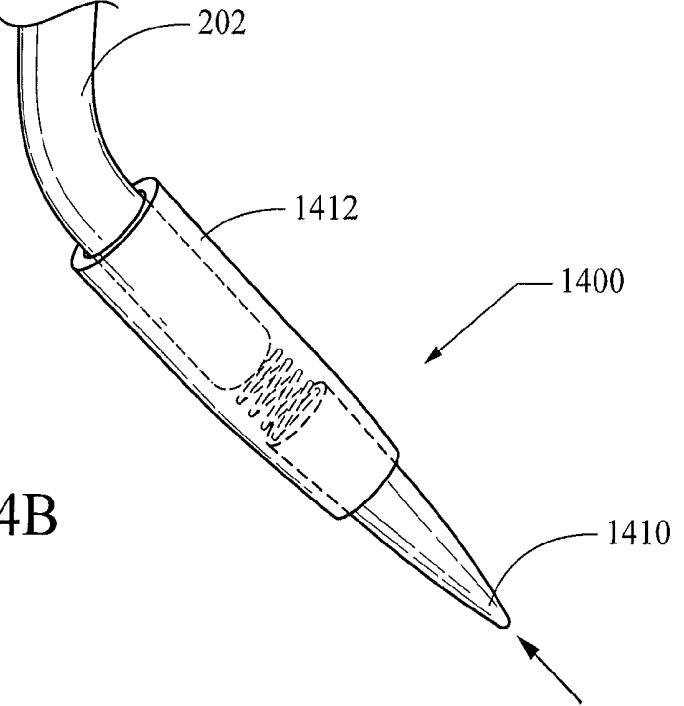

Fig. 14B

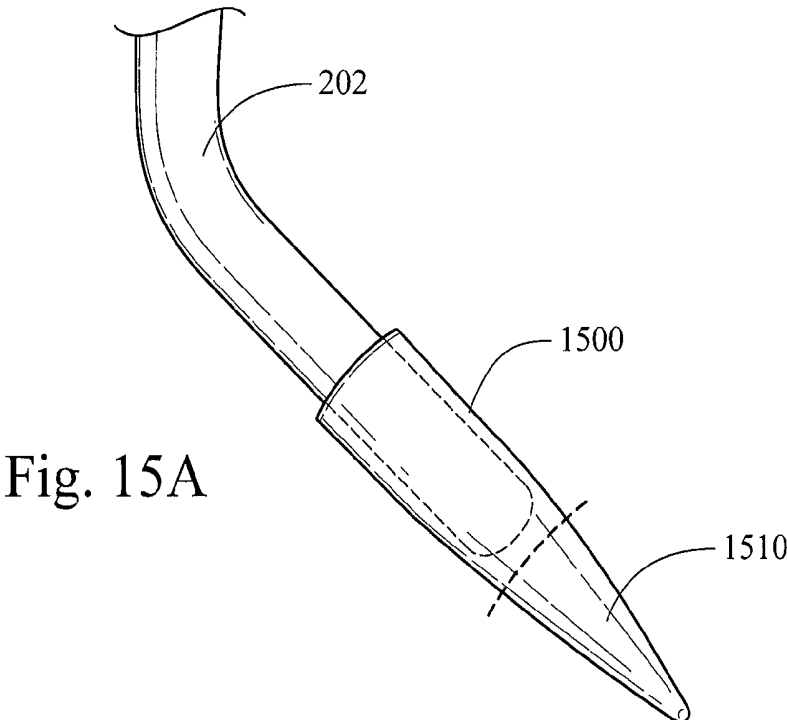

Fig. 15A

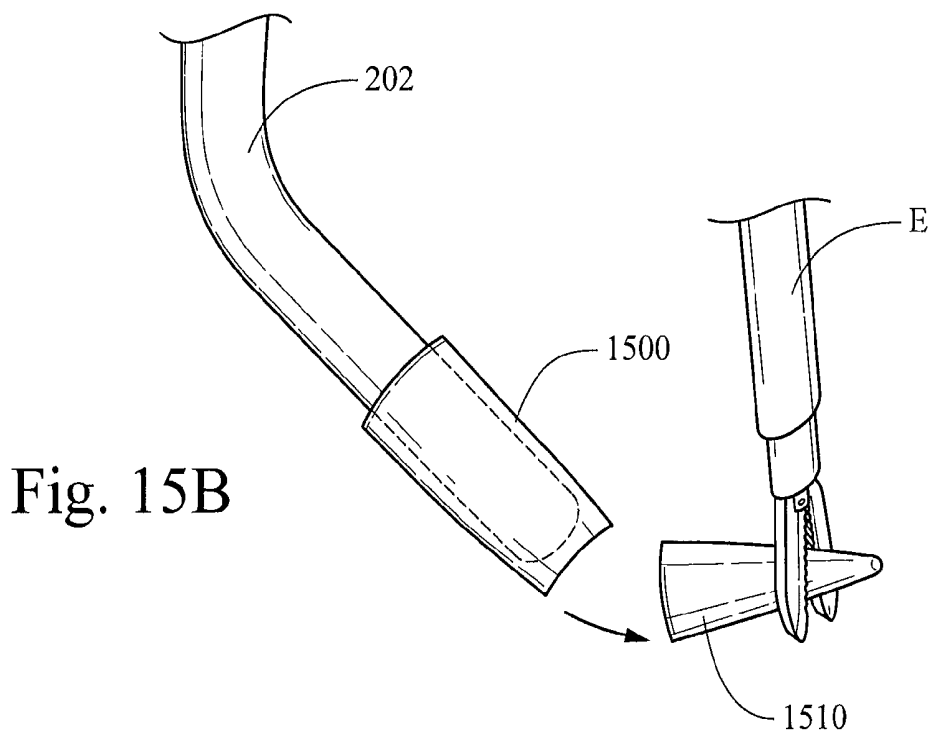
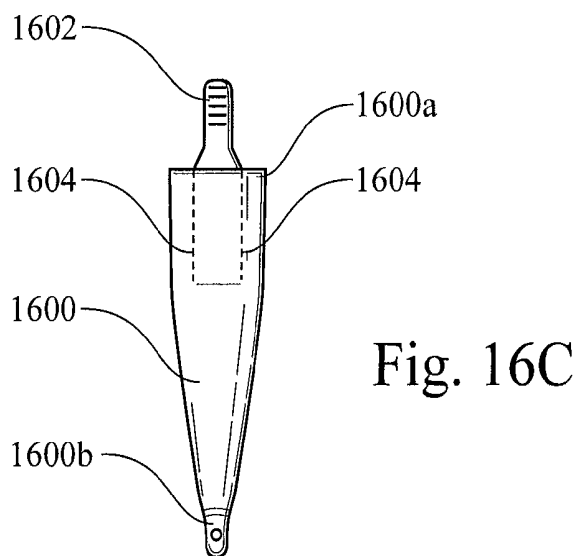
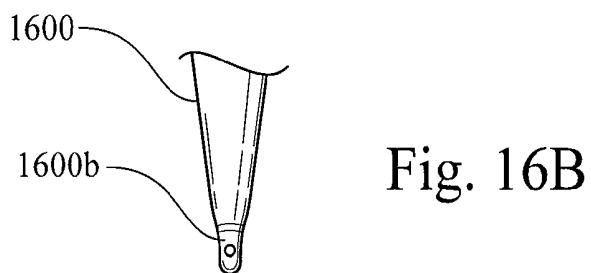
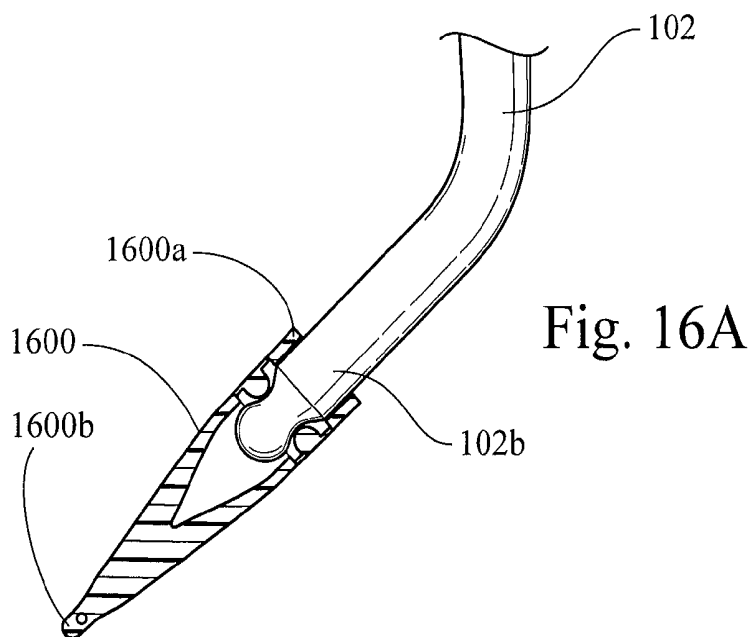

Fig. 15B



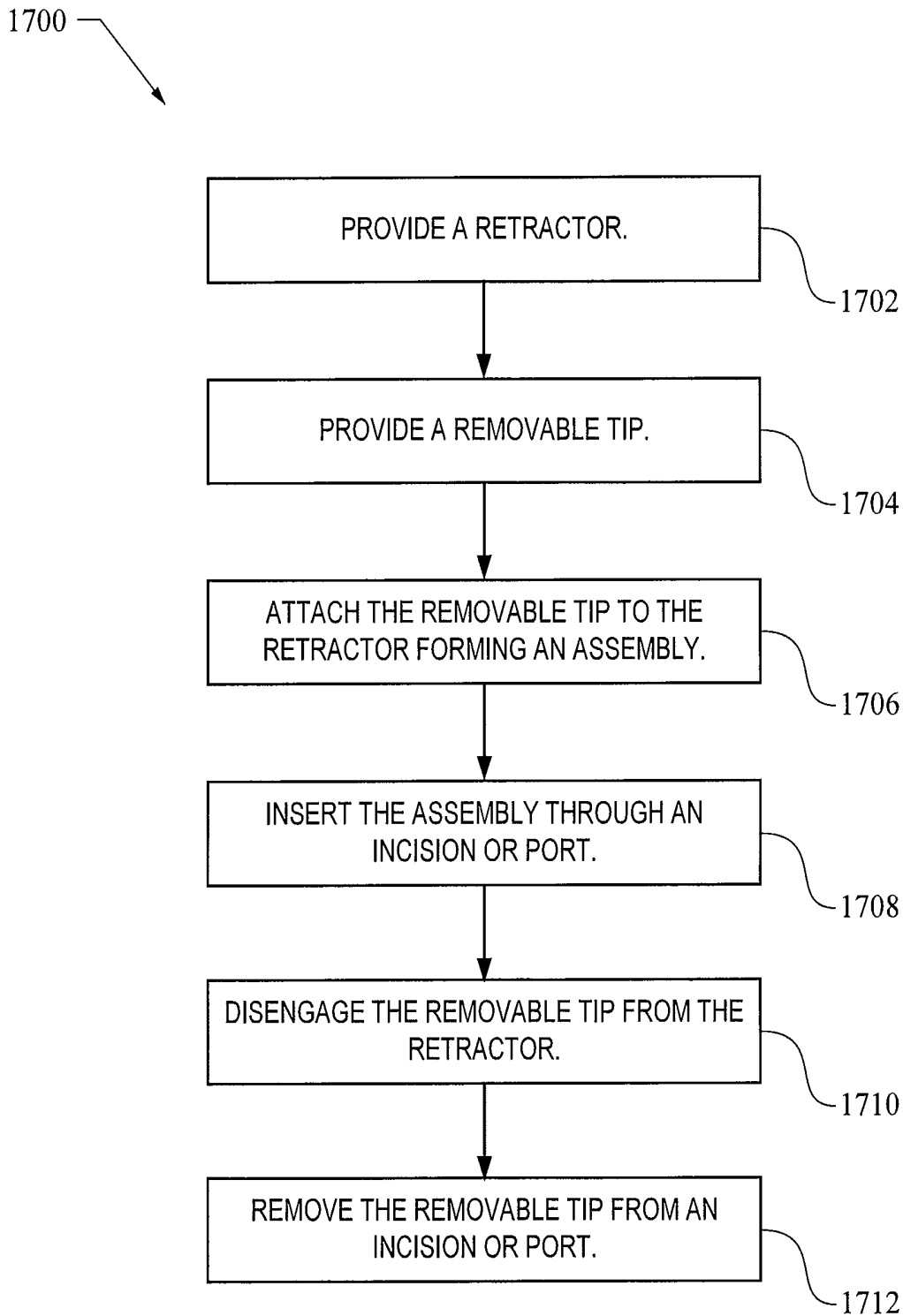

Fig. 17

REMOVABLE MEDICAL RETRACTOR TIP

RELATED APPLICATIONS

[0001] This application claims the benefit of priority from U.S. Provisional Application No. 61/651,803, filed May 25, 2012, and titled "Removable Medical Retractor Tip", the contents of which is incorporated herein by reference.

TECHNICAL FIELD

[0002] The present invention relates to medical devices and more specifically, instruments used in conjunction with laparoscopic surgery.

BACKGROUND

[0003] Laparoscopic surgical procedures generally involve inflating a bodily cavity with a gas, such as the abdomen, to provide better visibility of the surgical site. Such gasses may include carbon dioxide. After the surgical site is insufflated, the bodily cavity may be punctured using a trocar device for the purposes of inserting surgical tools such as a laparoscopic camera, cutting and manipulating tools, etc. For example, when performing laparoscopic surgery in the abdominal area, the trocar device is utilized to puncture the peritoneum. Thereafter, a laparoscopic retractor may be inserted through the puncture site and directed to the targeted anatomy to assist in retracting and holding certain bodily organs and tissue, thereby exposing the surgical field for the procedure. Maintaining adequate vision of the target or surgical field during laparoscopic procedures is critical to a successful laparoscopic procedure, as inadequate ability to visualize anatomical structures is a common complication of laparoscopic procedures, and can lead to conversion from a laparoscopic to an open procedure.

[0004] Laparoscopic surgery has many advantages over traditional open surgery in that it generally takes less time to complete, the patient is likely to experience less severe post-operative pain, and the incisions leave less noticeable scarring as compared to open surgery. Additionally, hospital recovery time and costs are generally reduced.

[0005] Despite the benefits of laparoscopic surgery, such surgery is often difficult to perform due to the effort required to arrive at adequate exposure of the surgical field. This is especially true in the case of inserting a retractor into a larger patient due to, for example, the distribution of adipose tissue over the preferred insertion site. For example, after the initial insertion is made, the retractor must be navigated through numerous layers of materials, including the skin, adipose tissue, etc. to reach the abdominal cavity and from there the target anatomy site. The materials through which the retractor is navigated are malleable and flexible, and accordingly, the incision does not remain fixed relative to the skin, adipose tissue, etc. Thus, inserting the retractor through the layers of material, especially when the patient has a thicker layer of adipose tissue over the insertion site, is difficult and results in a phenomenon called "tenting", wherein the retractor becomes stuck in the layers of material that have moved relative to the insertion point. This delays the procedure until the end of the retractor finally locates the incision into the abdominal cavity. Because laparoscopic retractors typically have a rounded end to facilitate easy insertion through the skin and into the abdominal cavity, the length of the end dictates how much adipose tissue can be accommodated. The more the adipose layers must be compressed to insert the insertion

end, the more likely the incision path becomes difficult to navigate. Although the insertion end of the retractor could be lengthened, a long retractor end impedes the medical procedure once it has been inserted, particularly in surgical areas having space constraints such as the pelvic area. Accordingly, present retractors do not provide an adequate solution to performing efficient laparoscopic surgery on those patients with additional adipose tissue over the preferred insertion site.

BRIEF SUMMARY

[0006] In a first aspect, a removable tip is provided comprising a substantially conical-shaped body comprising a proximal body portion and a distal body portion, wherein the proximal body portion comprises a substantially hollow portion and is configured for receiving a distal portion of a medical retractor, and wherein the distal body portion is atraumatic.

[0007] In a second aspect, a medical retractor system is provided, comprising a removable tip having a substantially conical-shaped body comprising a proximal body portion and a distal body portion, wherein the proximal body portion comprises a substantially hollow portion and is configured for receiving a distal portion of a medical retractor, and wherein the distal body portion is atraumatic; a disengagement means in communication with the substantially conical-shaped body configured to disengage the substantially conical-shaped body from a distal portion of a medical retractor; and a medical retractor having a proximal portion and a distal portion, wherein the distal portion is connected to the removable tip.

[0008] In a third aspect, a method for using a medical retractor system is provided, comprising the steps of providing a medical retractor comprising a proximal portion and a distal portion; and providing a removable tip comprising a substantially conical-shaped body comprising a proximal body portion and a distal body portion, wherein the proximal body portion comprises a substantially hollow portion and is configured for receiving the distal portion of the medical retractor, and wherein the distal body portion is atraumatic.

BRIEF DESCRIPTION OF THE SEVERAL VIEWS OF THE DRAWINGS

[0009] The embodiments will be further described in connection with the attached drawing figures. It is intended that the drawings included as a part of this specification be illustrative of the exemplary embodiments and should in no way be considered as a limitation on the scope of the invention. Indeed, the present disclosure specifically contemplates other embodiments not illustrated but intended to be included in the claims. Moreover, it is understood that the figures are not necessarily drawn to scale.

[0010] FIG. 1A illustrates a perspective view of an exemplary retractor attached to an exemplary removable tip;

[0011] FIG. 1B illustrates a perspective view of the exemplary retractor detached from the exemplary removable tip illustrated in FIG. 1A;

[0012] FIG. 1C illustrates a perspective view of a portion of the exemplary retractor detached from the exemplary removable tip illustrated in FIG. 1B at the circle 1C;

[0013] FIG. 2A illustrates a perspective view of an exemplary retractor attached to another exemplary removable tip;

[0014] FIG. 2B illustrates a bottom perspective view of the exemplary removable tip illustrated in FIG. 2A;

[0015] FIG. 2C illustrates a perspective view of the exemplary removable tip illustrated in FIG. 2A just prior to disengagement from the exemplary retractor;

[0016] FIG. 2D illustrates a perspective view of the exemplary removable tip illustrated in FIG. 2A disengaged from the distal-most portion of the exemplary retractor;

[0017] FIG. 2E illustrates a perspective view of the exemplary removable tip illustrated in FIG. 2A being removed through an incision;

[0018] FIG. 3A illustrates a perspective view of an exemplary retractor attached to another exemplary removable tip;

[0019] FIG. 3B illustrates a perspective view of the exemplary removable tip illustrated in FIG. 3A in the process of disengagement from the distal-most portion of the exemplary retractor;

[0020] FIG. 3C illustrates a perspective view of the exemplary removable tip illustrated in FIG. 3A being disengaged from the distal-most portion of the exemplary retractor;

[0021] FIG. 3D illustrates a perspective view of the exemplary removable tip illustrated in FIG. 3A being removed through an incision;

[0022] FIG. 4A illustrates a perspective partial cross-sectional view of an exemplary retractor attached to another exemplary removable tip;

[0023] FIG. 4B illustrates a perspective view of the exemplary removable tip illustrated in FIG. 4A;

[0024] FIG. 4C illustrates a perspective view of the exemplary removable tip illustrated in FIG. 4A just prior to disengagement from the exemplary retractor;

[0025] FIG. 4D illustrates a perspective view of the exemplary removable tip illustrated in FIG. 4A disengaged from the exemplary retractor;

[0026] FIG. 5A illustrates a perspective view of an exemplary retractor attached to another exemplary removable tip;

[0027] FIG. 5B illustrates a perspective view of the exemplary removable tip illustrated in FIG. 5A disengaged from the exemplary retractor;

[0028] FIG. 6A illustrates a perspective view of an exemplary retractor attached to another exemplary removable tip;

[0029] FIG. 6B is a cross-sectional view of the removable tip taken along line 6A-6A in FIG. 6A;

[0030] FIG. 6C illustrates a perspective view of the exemplary removable tip illustrated in FIG. 6A disengaged from the exemplary retractor;

[0031] FIG. 7A illustrates a perspective view of an exemplary retractor attached to another exemplary removable tip;

[0032] FIG. 7B illustrates a perspective view of the exemplary removable tip illustrated in FIG. 7A disengaged from the exemplary retractor;

[0033] FIG. 8A illustrates a perspective view of an exemplary retractor attached to another exemplary removable tip;

[0034] FIGS. 8B-8E illustrate a perspective view of the exemplary removable tip illustrated in FIG. 8A partially or fully disengaged from the exemplary retractor;

[0035] FIG. 9A illustrates a perspective view of an exemplary retractor attached to another exemplary removable tip;

[0036] FIG. 9B illustrates a perspective view of the exemplary removable tip illustrated in FIG. 9A in a collapsed configuration;

[0037] FIGS. 9C-9E illustrate cross-sectional views of the exemplary removable tip illustrated in FIG. 9A showing the collapsing mechanism;

[0038] FIG. 10A illustrates a perspective view of an exemplary retractor attached to another exemplary removable tip;

[0039] FIG. 10B illustrates a perspective view of the exemplary removable tip illustrated in FIG. 10A in a retracted position;

[0040] FIGS. 10C-10E illustrate cross-sectional views of the exemplary removable tip illustrated in FIG. 10A comprising various retracting mechanisms;

[0041] FIG. 11A illustrates a perspective view of an exemplary retractor attached to another exemplary removable tip;

[0042] FIG. 11B illustrates a perspective view of the exemplary removable tip illustrated in FIG. 11A in a deflated configuration;

[0043] FIGS. 11C-11D illustrate cross-sectional views of the exemplary removable tip illustrated in FIG. 11A further comprising an inflation mechanism;

[0044] FIG. 12A illustrates a perspective view of an exemplary retractor attached to another exemplary removable tip;

[0045] FIG. 12B illustrates a perspective view of the exemplary removable tip illustrated in FIG. 12A in a partially retracted configuration;

[0046] FIG. 13A illustrates a perspective view of an exemplary retractor attached to another exemplary removable tip;

[0047] FIG. 13B illustrates a perspective view of the exemplary removable tip illustrated in FIG. 13A disengaged from the exemplary retractor;

[0048] FIG. 14A illustrates a perspective view of an exemplary retractor attached to another exemplary removable tip;

[0049] FIG. 14B illustrates a perspective view of the exemplary removable tip illustrated in FIG. 14A in a retracted configuration;

[0050] FIG. 15A illustrates a perspective view of an exemplary retractor attached to another exemplary removable tip;

[0051] FIG. 15B illustrates a perspective view of the exemplary removable tip illustrated in FIG. 15A in a shortened configuration;

[0052] FIG. 16A illustrates a perspective partial cross-sectional view of an exemplary retractor attached to another exemplary removable tip;

[0053] FIG. 16B illustrates a perspective side view of the distal end of the exemplary removable tip illustrated in FIG. 16A;

[0054] FIG. 16C illustrates a perspective view of the exemplary removable tip illustrated in FIG. 16A disengaged from the exemplary retractor; and

[0055] FIG. 17 illustrates a method of use of an exemplary retractor-removable tip system, such as those illustrated herein and equivalents thereto.

DETAILED DESCRIPTION OF PRESENTLY PREFERRED EMBODIMENTS

[0056] The exemplary embodiments illustrated provide the discovery of systems, methods, and apparatuses used in conjunction with laparoscopic surgery to improve efficiency and navigation to the target anatomy while maintaining adequate exposure of the target anatomy.

[0057] Diseases and conditions contemplated for treatment include, but are not limited to, those involving the pelvic region as well as any other bodily region or field benefiting from improved navigation to a target site.

[0058] The present invention is not limited to those embodiments illustrated herein, but rather, the disclosure includes all equivalents including those of different shapes, sizes, and configurations. The systems, devices, and methods may be used in any field benefiting retractors or devices to aid in the navigation to a target site. Additionally, the devices and

methods are not limited to being used with human beings; others are contemplated, including but not limited to, animals.

[0059] Unless otherwise defined, all technical and scientific terms used herein have the same meaning as commonly understood by one of ordinary skill in the art. In case of conflict, the present document, including definitions, will control. Preferred methods and materials are illustrated below, although apparatuses, methods, and materials similar or equivalent to those illustrated herein may be used in practice or testing. All publications, patent applications, patents and other references mentioned herein are incorporated by reference in their entirety. The materials, methods, and examples disclosed herein are illustrative only and not intended to be limiting.

[0060] The terms “comprise(s),” “include(s),” “having,” “has,” “can,” “contain(s),” and variants thereof, as used herein, are intended to be open-ended transitional phrases, terms, or words that do not preclude the possibility of additional acts or structures. The present disclosure also contemplates other embodiments “comprising,” “consisting of” and “consisting essentially of,” the embodiments or elements presented herein, whether explicitly set forth or not.

[0061] The term “proximal,” as used herein, refers to a direction that is generally towards a physician during a medical procedure.

[0062] The term “distal,” as used herein, refers to a direction that is generally towards a target site within a patient’s anatomy during a medical procedure.

[0063] A more detailed description of the embodiments will now be given with reference to FIGS. 1A-17. Throughout the disclosure, like reference numerals and letters refer to like elements. The present disclosure is not limited to the embodiments illustrated; to the contrary, the present disclosure specifically contemplates other embodiments not illustrated but intended to be included in the claims.

[0064] FIG. 1A illustrates a perspective view of exemplary retractor **102** attached to exemplary removable tip **100**, FIG. 1B illustrates a perspective view of exemplary retractor **102** detached from exemplary removable tip **100**, and FIG. 1C illustrates a perspective view of a portion of exemplary retractor **102** detached from exemplary removable tip **100** illustrated in FIG. 1B at the circle 1C. Referring to FIG. 1A, exemplary retractor **102** includes proximal portion **102a** and distal portion **102b**. The distal-most portion of retractor **102** has been modified to receive a female proximal portion **100a** of removable tip **100**. Retractor **102** is designed for insertion through a laparoscopic incision or port and is preferably used to aid in the positioning and or holding of organs or tissues during a diagnostic, exploratory, or therapy procedure. For example, retractor **102** may be used to help position organs and tissues during, for example, rectal dissections, pelvic floor grafting, uterine procedures, and bowel procedures. Moreover the use of two or more retractors **102** having removable tips **100** are contemplated.

[0065] The distal-most end of retractor **102** is atraumatic, pinched, and tapered. Proximal portion **100a** of removable tip **100** is substantially hollow to receive retractor **102** via a snap fit or other attachment means, including but not limited to, a friction fit. A screw/threaded attachment means may also be used, recognizing that such an attachment means may be more difficult to disengage when in use due to the space constraints of the working environment.

[0066] Removable tip **100** is a substantially conical-shaped removable piece configured for attachment to distal portion **102b** of retractor **102** to improve retractor **102** insertion, especially in the case of patients having large amounts of adipose tissue. Distal portion **100b** of removable tip **100** is tapered and atraumatic for ease of insertion and navigation through an incision and to prevent damaging organs and tissue. Although removable tip **100** is illustrated as being configured to receive retractor **102** therein, retractor **102** may be configured to receive removable tip **100** therein. In other words, retractor **102** may be configured with a female distal end **102b** into which a male proximal end **100a** of removable tip **100** may be inserted and affixed thereto. In any event, in either configuration, it is generally preferred, although not required, that a medical retractor be free from numerous crevasses or other surface features that may make sterilization for reuse difficult.

[0067] The additional overall length provided by removable tip **100** makes it easier for retractor **102** to be inserted through the incision during a laparoscopic procedure. The longer the removable tip **100**, the more adipose tissue can be accommodated. In other words, fashioning removable tip **100** to have a longer dimension will allow it to accommodate thicker skin, fat, and muscle layers. However, because removable tip **100** is removable from retractor **102** after retractor **102** is inserted, the space constraints addressed by a retractor **102** having a minimized overall size may be achieved.

[0068] Referring to FIGS. 1B and 1C, removable tip **100** is illustrated as disengaged from retractor **102** by being pulled distally from retractor **102**, using, for example, an instrument such as endo grippers. Once removable tip **100** is disengaged from retractor **102**, retractor **102** alone is of a sufficient length to perform its retracting functions. The distal-most portion of retractor **102** includes a tapered atraumatic portion **104** for ease of insertion through an incision or port that will not damage tissue or organs once disengaged from removable tip **100**.

[0069] Removable tip **100** is approximately 5 cm long but other lengths are contemplated depending upon the amount of tissue needed through which to introduce retractor **102**. For example, removable tips **100** having a variety of lengths may be manufactured to accommodate various amounts of adipose or other tissues and could be provided as part of a kit. For example, a first removable tip **100** may have a length of 5 cm, a second may have a length of 8 cm, and a third may have a length of 10 cm. Accordingly, the user may choose the most appropriately-sized removable tip **100** for attachment to retractor **102** based on the clinical facts and circumstances. In some cases, if the material through which retractor **102** needs to be inserted is sufficiently thin, removable tip **100** may not be needed.

[0070] Removable tip **100** is made from plastic, such as polypropylene, although other materials are contemplated, including but not limited to TPE (thermoplastic elastomers), polycarbonate, polystyrene, an elastomeric material capable of stretching over the distal-most portion of retractor **102**, molded silicone, and metal. Removable tip **100** may be configured from two or more materials, including those having different properties, characteristics or features, including but not limited to, one material having a different hardness from the other. For example, distal portion **100b** of removable tip **100** may be configured from a harder material than, for example, proximal portion **100a** of removable tip **100**. The harder material may provide the distal portion **100b** with an

improved ability to pass through the tissue during placement, whereas the softer material may provide the proximal portion **100a** with an improved ability to engage with the distal end **102b** of the retractor **102**.

[0071] Removable tip **100** preferably is disposable, low-cost, and is intended for single use, although it may be configured to be reusable. Retractor **102** is preferably also low-cost and may be manufactured for either single use or for multiple uses.

[0072] FIG. 2A illustrates a perspective view of exemplary retractor **202** attached to exemplary removable tip **200**, FIG. 2B illustrates a bottom perspective view of removable tip **200**, FIG. 2C illustrates a perspective view of removable tip **200** just prior to disengagement from retractor **202**, FIG. 2D illustrates a perspective view of removable tip **200** disengaged from the distal-most portion of retractor **202**, and FIG. 2E illustrates a perspective view of removable tip **200** being removed through an incision. Referring to FIGS. 2A-2B, retractor **202** is similar to the retractor embodiment discussed above in connection with FIGS. 1A-1C. The distal-most end of retractor **202** is atraumatic and rounded. For example, retractor **202** is designed for insertion through a laparoscopic incision or port and is preferably used to aid in the positioning and or holding of organs or tissues during a diagnostic, exploratory, or therapy procedure. For example, retractor **202** may be used to help position organs and tissues during, for example, rectal dissections, pelvic floor grafting, uterine procedures, and bowel procedures. Although only a single retractor **202** is illustrated, the use of two or more retractors **202** having removable tips **200** is also contemplated.

[0073] Removable tip **200** is a substantially conical-shaped removable piece configured for attachment to distal portion **202b** of retractor **202** to improve the insertion capability of retractor **202**, especially in the case of patients having large amounts of adipose tissue. Distal portion **200b** of removable tip **200** is tapered and atraumatic for ease of insertion and navigation through an incision, as well as to prevent causing damage to organs and tissue. Proximal portion **200a** of removable tip **200** is substantially hollow so as to receive retractor **202** therein. As will be explained below, removable tip **200** is configured to be disengaged from retractor **202** by breaking the removable tip **200** at snap point **204**. For example, referring to FIG. 2C, an instrument, such as a forceps or endo gripper **E** is positioned at and grabs distal portion **200b** of removable tip **200**. Endo gripper **E** is then moved in the direction of arrow **A** to cause distal portion **200b** of removable tip **200** to break from supporting neck **206** at snap point **204**, thereby releasing the engagement of removable tip **200** with retractor **202**. Removable tip **200** includes supporting neck **206** that maintains, at least temporarily, communication with retractor **202** even after distal portion **200b** of removable tip **200** is broken at snap point **204**.

[0074] Referring to FIG. 2D, an instrument, such as endo grippers **E** is used to back feed removable tip **200** proximally along retractor **202** in the direction of arrow **B** such that removable tip **200** is able to be removed from the area of the laparoscopic procedure. Referring to FIG. 2E, removable tip **200** continues to be back-thread proximally along retractor **202** in the direction of arrow **C** such that it is pushed through the incision point at the skin and the abdominal cavity, and is subsequently removed from the procedure. Once removable tip **200** is disengaged from retractor **202**, retractor **202** alone is of a sufficient length to perform its retracting functions.

[0075] Removable tip **200** is approximately 5 cm long but other lengths are contemplated depending upon the amount of tissue through which retractor **202** is to be introduced. For example, multiple removable tips **200** each having a variety of lengths may be manufactured to accommodate various amounts of adipose or other tissues. For example, a first removable tip **200** may have a length of 5 cm, a second may have a length of 8 cm, and a third may have a length of 10 cm. The removable tips **200** having various lengths may be included in a kit supplied with retractor **202**. Accordingly, the user may choose the most appropriately-sized removable tip **200** for attachment to retractor **202** based on the clinical facts and circumstances. In some cases, the material through which retractor **202** needs to be inserted may be sufficiently thin such that removable tip **200** may not be needed.

[0076] Removable tip **200** is made from plastic, such as polypropylene, although other materials are contemplated, including but not limited to TPE (thermoplastic elastomers), polycarbonate, polystyrene, nylon, and molded silicone. Removable tip **200** may be configured from two or more materials, including those having different properties, characteristics or features, including but not limited to, one having a different hardness from the other. For example, distal portion **200b** of removable tip **200** may be configured from a harder material than, for example, proximal portion **200a** of removable tip **200**.

[0077] Removable tip **200** preferably is disposable, low-cost, and is intended for single use, although it may be configured to be reusable. Retractor **202** is preferably also low-cost and may be manufactured for single use or for multiple uses.

[0078] One advantage of the configuration of removable tip **200**, among many, is that removable tip **200** is never completely disengaged from the retractor **202** while within the patient. Accordingly, there is very little risk of removable tip **200** becoming lost or forgotten within the patient.

[0079] FIG. 3A illustrates a perspective view of exemplary retractor **202** attached to exemplary removable tip **300**, FIG. 3B illustrates a perspective view of removable tip **300** in the process of disengagement from the distal-most portion of retractor **202**, FIG. 3C illustrates a perspective view of removable tip **300** being disengaged from the distal-most portion of retractor **202**, and FIG. 3D illustrates a perspective view of removable tip **300** being removed through an incision. Although a single retractor **202** is illustrated, the use of two or more retractors **202** each having removable tips **300** is contemplated.

[0080] Removable tip **300** includes proximal portion **300a** and distal portion **300b**. Removable tip **300** is a substantially conical-shaped removable piece configured for attachment to distal portion **202b** of retractor **202** to improve retractor insertion, especially in the case of patients having large amounts of adipose tissue. Referring to FIG. 3A, proximal portion **300a** of removable tip **300** is substantially hollow and configured for receiving distal portion **202b** of retractor **202**, via, for example, a snap fit or other attachment means, including but not limited to a friction fit. Distal portion **300b** of removable tip **300** is tapered and atraumatic for ease of insertion and navigation through an incision and to prevent damaging organs and tissue. In this particular embodiment, removable tip **300** includes pull cord **302** connected to ring **304** that when pulled, breaks removable tip **300** at perforations **308**, thereby causing removable tip **300** to release its grip on retractor **202** such that removable tip **300** may be removed. Ring **304** or

other retaining means is intended to remain outside patient while retractor **202** equipped with removable tip **300** is being inserted into a patient.

[0081] Referring to FIGS. 3B and 3C, ring **304** is pulled proximally in the direction of arrow F thereby causing perforations **308** (illustrated in FIG. 3A) to break and create break flap **306** in the direction of arrow D. The entirety of tip **300** is then pulled proximally along retractor **202** in the direction of arrow G. Referring to FIG. 3D, removable tip **300** continues to be back-thread proximally along retractor **202** in the direction of arrow H such that it is pushed through the incision point at skin and the abdominal cavity and is able to be removed from the procedure. Once removable tip **300** is disengaged from retractor **202**, retractor **202** alone is of a sufficient length to perform its retracting functions.

[0082] Removable tip **300** is approximately 15 cm long but other lengths are contemplated depending upon the amount of tissue needed through which to introduce retractor **202**. For example, multiple removable tips **300** having a variety of lengths may be manufactured to accommodate various amounts of adipose or other tissues. For example, a first removable tip **300** may have a length of 15 cm, another may have a length of 18 cm, and another may have a length of 20 cm. Accordingly, the user may choose the most appropriately-sized removable tip **300** for attachment to retractor **202** based on the clinical facts and circumstances. In some cases, if the material through which retractor **202** needs to be inserted is sufficiently thin, removable tip **300** may not be needed.

[0083] Removable tip **300** is made from plastic, such as polypropylene, although other materials are contemplated, including but not limited to TPE (thermoplastic elastomers), polycarbonate, polystyrene, nylon, and molded silicone. Removable tip **300** may be configured from two or more materials, including those having different characteristics or features, including but not limited to, one having a different hardness from the other. For example, distal portion **300b** of removable tip **300** may be configured from a harder material than, for example, proximal portion **300a** of removable tip **300**.

[0084] Removable tip **300** preferably is disposable, low-cost, and is intended for single use, although it may be configured to be reusable. One advantage of the configuration of removable tip **300**, among many, is that removable tip **300** is never completely disengaged from retractor **202** while within the patient. Accordingly, there is very little risk of removable tip **300** becoming lost or forgotten within the patient.

[0085] FIG. 4A illustrates a perspective partial cross-sectional view of exemplary retractor **102** attached to exemplary removable tip **400**, FIG. 4B illustrates a perspective view of removable tip **400**, FIG. 4C illustrates a perspective view of removable tip **400** just prior to disengagement from the exemplary retractor, and FIG. 4D illustrates a perspective view of removable tip **400** disengaged from the exemplary retractor. The use of two or more retractors **102** having removable tips **400** are contemplated.

[0086] Referring to FIGS. 4A and 4B, removable tip **400** includes proximal portion **400a** and distal portion **400b**. Removable tip **400** is a substantially conical-shaped removable piece configured for attachment to distal portion **102b** of retractor **102** to improve retractor insertion, especially in the case of patients having large amounts of adipose tissue. Distal portion **400b** of removable tip **400** is tapered and atraumatic for ease of insertion and navigation through an incision and to

prevent damaging organs and tissue. Proximal portion **400a** of removable tip **400** is substantially hollow and configured for receiving distal portion **102b** of retractor **102**, via, for example, a snap fit or other attachment means, including but not limited to a friction fit. In the particular embodiment illustrated, the distal portion **102b** of the retractor **102** comprises one or more grooves or indentations that are configured to receive one or more ridges or protrusion on the inside of removable tip **400** to facilitate engagement between therebetween. Removable tip **400** includes pull tab **402** that when pulled, breaks removable tip **400** at perforations **404**, thereby causing removable tip **400** to release its grip on retractor **102** such that removable tip **400** may be removed.

[0087] Referring to FIGS. 4C and 4D, an instrument, such as a forceps or an endo gripper E is positioned at and grasps pull tab **402**. The endo gripper E pulls pull tab **402** in the direction of arrow J away from removable tip **400**, thereby causing perforations **404** to break until perforation stop **406** such that removable tip **400** remains one piece. Removable tip **400** is disengaged from retractor **102** and can be removed through any incision or port, or after the procedure is complete. Once removable tip **400** is disengaged from retractor **102**, retractor **102** alone is of a sufficient length to perform its retracting functions.

[0088] Removable tip **400** is approximately 5 cm long but other lengths are contemplated depending upon the amount of tissue needed through which to introduce retractor **102**. For example, multiple removable tips **400** having a variety of lengths may be manufactured to accommodate various amounts of adipose or other tissues. For example, a first removable tip **400** may have a length of 5 cm, another may have a length of 8 cm, and another may have a length of 10 cm. Accordingly, the user may choose the most appropriately-sized removable tip **400** for attachment to retractor **102** based on the clinical facts and circumstances. In some cases, if the material through which retractor **102** needs to be inserted is sufficiently thin, removable tip **400** may not be needed.

[0089] Removable tip **400** is made from plastic, such as polypropylene, although other materials are contemplated, including but not limited to TPE (thermoplastic elastomers), polycarbonate, polystyrene, nylon, and molded silicone. Removable tip **400** may be configured from two or more materials, including those having different characteristics or features, including but not limited to, one having a different hardness from the other. For example, distal portion **400b** of removable tip **400** may be configured from a harder material than, for example, proximal portion **400a** of removable tip **400**. Removable tip **400** preferably is disposable, low-cost, and is intended for single use, although it may be configured to be reusable.

[0090] FIG. 5A illustrates a perspective view of exemplary retractor **202** attached to exemplary removable tip **500**, and FIG. 5B illustrates a perspective view of removable tip **500** disengaged from exemplary retractor **202**. The use of two or more retractors **202** having removable tips **500** are contemplated.

[0091] Removable tip **500** includes proximal portion **500a** and distal portion **500b**. Removable tip **500** is a substantially conical-shaped removable piece configured for attachment to distal portion **202b** of retractor **202** to improve retractor insertion, especially in the case of patients having large amounts of adipose tissue. Distal portion **500b** of removable tip **500** is tapered and atraumatic for ease of insertion and navigation through an incision and to prevent damaging organs and

tissue. Proximal portion **500a** of removable tip **500** is substantially hollow and configured for receiving distal portion **202b** of retractor **202**.

[0092] Removable tip **500** includes pull cord **502** connected to ring **506** that when pulled, breaks removable tip **500** at spiral perforations **504** disposed about removable tip **500**, thereby causing removable tip **500** to unwind and release its grip on retractor **202** such that removable tip **500** may be removed. Ring **506** or other retaining means is intended to remain outside patient while retractor **202** equipped with removable tip **500** is being inserted into a patient.

[0093] Ring **506** is pulled proximally in the direction of arrow **K**, thereby causing perforations **504** to break and unravel tip **500**. The entirety of tip **500** is then pulled out of the way from the area of retractor **202**. For example, ring **506** or any portion of pull cord **502** may be taped, clipped, or adhered, to an article such as the skin's surface, to maintain the placement of removable tip **500**. Once removable tip **500** is disengaged from retractor **202**, retractor **202** alone is of a sufficient length to perform its retracting functions. After retractor **202** is removed from the incision site, removable tip **500** is likewise able to be removed from the incision site.

[0094] One advantage of the configuration of removable tip **500**, among many, is that removable tip **500** is always connected to retractor **202** or the outside surface of the patient during the procedure. Accordingly, there is very little risk of removable tip **500** becoming lost or forgotten within the patient.

[0095] Removable tip **500** is approximately 15 cm long but other lengths are contemplated depending upon the amount of tissue needed through which to introduce retractor **202**. For example, multiple removable tips **500** having a variety of lengths may be manufactured to accommodate various amounts of adipose or other tissues and provided with retractor **202** as a kit. For example, a first removable tip **500** may have a length of 15 cm, another may have a length of 18 cm, and another may have a length of 20 cm. Accordingly, the user may choose from the kit the most appropriately-sized removable tip **500** for attachment to retractor **202** based on the clinical facts and circumstances. In some cases, if the material through which retractor **202** needs to be inserted is sufficiently thin, removable tip **500** may not be needed.

[0096] Removable tip **500** is made from plastic, such as polypropylene, although other materials are contemplated, including but not limited to TPE (thermoplastic elastomers), polycarbonate, polystyrene, nylon, and molded silicone. Removable tip **500** may be configured from two or more materials, including those having different properties, characteristics or features, including but not limited to, one having a different hardness from the other. For example, distal portion **500b** of removable tip **500** may be configured from a harder material than, for example, proximal portion **500a** of removable tip **500**. Removable tip **500** preferably is disposable, low-cost, and is intended for single use, although it may be reusable.

[0097] FIGS. 6A-6C illustrate another embodiment of a removable tip **600** for use with retractor **202**. In this particular embodiment, the removable tip **600** comprises a pair of break lines **610** disposed longitudinally along the distal portion thereof. The break lines **610** are configured to break apart as the removable tip **600** is pulled in a proximal direction to thereby allow the removable tip **600** to be retracted in a proximal direction along the retractor **202**. Pull tabs may be

provided on the proximal end of the removable tip **600** to facilitate the application of the breaking force and removal of the removable tip **600**.

[0098] FIGS. 7A-7B illustrate another embodiment of a removable tip **700** for use with retractor **202**. In this particular embodiment, the removable tip **700** includes a pull cable **710** attached to the distal end the removable tip **700**. Once the retractor **202** is position, the user pulls on the pull cable **710** with sufficient force to separate and remove the removable tip **700** from the retractor **202**. The distal end of the pull cable **710** may include a loop to facilitate grasping thereof.

[0099] FIGS. 8A-8E illustrate another embodiment of a removable tip **800** for use with a retractor **202**. In this particular embodiment, the removable tip **800** comprises a foldable distal portion **810** that may be folded to either permit removal or reduce the overall length thereof. Referring to FIG. 8B, a forceps or endo grasper **E** is used to fold the distal portion **810**. As show in FIG. 8C, the folding of the distal portion **810** exposes an opening in the removable tip **800**, thereby permitting the removable tip **800** to be retracted proximally along the retractor **202**. In the variation illustrated in FIGS. 8D-8E, the foldable distal portion **810** is folded and secured alongside the remaining portion of the removable tip **800**, thereby reducing the overall length thereof.

[0100] FIGS. 9A-9E illustrate another embodiment of a removable tip **900** for use with a retractor **202**. In this particular embodiment, the removable tip **900** comprises a collapsing mechanism **910** that permits the overall length of the removable tip **900** to be reduced. In particular, and as best seen in FIGS. 9C-9E, the collapsing mechanism **910** comprises a plurality of interior supports that are secured to telescoping portions of the removable tip **900**. A button or other activation device on the removable tip **900** is depressed to break the interior supports, thereby allowing the telescoping sections to be collapsed, as shown in FIG. 9B.

[0101] FIGS. 10A-10E illustrate another embodiment of a removable tip **1000** for use with a retractor **202**. In this particular embodiment, the removable tip **1000** comprises a retracting mechanism that permits the overall length of the removable tip **1000** to be reduced. With reference to FIGS. 10A-10C, the retracting mechanism includes a screw thread disposed on the outer surface of proximal portion **1010** which is configured to mate with a screw thread on the internal surface of distal portion **1012**. Rotation of the distal portion **1012** relative to the proximal portion **1010** causes the distal portion to move in a proximal direction relative to the retractor **202**, thereby allowing the overall length of the removable tip **1000** to be reduced. FIGS. 10D-10E illustrate an alternative arrangement wherein a bayonet connection is used in lieu of the screw connection. In the particular embodiments illustrated, the proximal portion **1010** is a separate component that is affixed to the distal end of the retractor **202**. However, it should be understood that the proximal portion **1010** could be integrally formed with or a formed into the distal end of the retractor **202**.

[0102] FIGS. 11A-11D illustrate another embodiment of a removable tip **1100** for use with a retractor **202**. In this particular embodiment, the removable tip **1100** comprises an inflatable balloon tip **1110** that is filled with saline. The saline is removed from the balloon tip **1110** to deflate and collapse the balloon tip **1110**, thereby reducing the overall length of the removable tip **1100**. With reference to FIG. 11B, the balloon tip **1110** is cut or punctured to allow the saline to escape. With reference to FIGS. 11C-11D, the removable tip

1100 further includes an inflation mechanism **1112** for delivering saline to or removing saline from the balloon tip **1110**. The balloon tip **1110** could comprise multiple chambers to allow removable tip **1100** to be inflated to various lengths or configuration.

[0103] FIGS. 12A-12B illustrate another embodiment of a removable tip **1200** for use with a retractor **202**. In this particular embodiment, the removable tip **1200** comprises a deformable and/or compressible material. As shown in FIG. 12A, a pull cable **1210** is attached the distal end of the removable tip **1200**. The pull cable **1210** passes proximally through a lumen or hollowed out portion of the removable tip **1200**, and then proximally through a lumen of the retractor **202**. Once the retractor **202** is in position, the user pulls the pull cable **1210** to invert the distal end of the removable tip **1200**. The distal end of the removable tip **1200** is then pulled back into the lumen or hollowed out portion of the removable tip **1200**, thereby reducing the overall length of the removable tip **1200**. In the particular embodiment illustrated, the distal portion of the removable tip **1200** is also pulled into the lumen of the retractor **202**. If the removable tip **1200** comprises a sufficiently compressible material, the removable tip may be pulled completely into the lumen of the retractor **202**.

[0104] FIGS. 13A-13B illustrate another embodiment of a removable tip **1300** for use with retractor **202**. In this particular embodiment, the removable tip **1300** includes a grasping mechanism **1310** attached to the distal end the removable tip **1300**. Once the retractor **202** is position, the user grasps the grasping mechanism **1310** with a forceps or endo grasper E with sufficient force to separate and remove the removable tip **1300** from the retractor **202**. In the particular embodiment illustrated, the grasping mechanism **1310** comprises a port in the distal end of the removable tip **1300**. However, other grasping mechanisms are contemplated, such a wire ring or suture loop.

[0105] FIGS. 14A-14B illustrate another embodiment of a removable tip **1400** for use with a retractor **202**. In this particular embodiment, the removable tip **1400** comprises a spring loaded retracting mechanism that permits the overall length of the removable tip **1400** to be reduced. In particular, the removable tip **1400** comprises a distal portion **1410** that is slidably coupled to a proximal portion **1412**, wherein a coil spring is disposed therebetween. Once the retractor **202** is in position, pressure is applied to the distal portion **1410** to cause the distal portion **1410** to move in a proximal direction relative to the proximal portion **1412** and the retractor **202**, thereby allowing the overall length of the removable tip **1400** to be reduced, as illustrated in FIG. 14B. A detent or similar mechanism may be provided between the distal portion **1410** and the proximal portion **1412** to secure the removable tip **1400** in a collapsed configuration. In the particular embodiments illustrated, the proximal portion **1412** is a separate component that is affixed to the distal end of the retractor **202**. However, it should be understood that the proximal portion **1412** could be integrally formed with or a formed into the distal end of the retractor **202**.

[0106] FIGS. 15A-15B illustrate another embodiment of a removable tip **1500** for use with a retractor **202**. In this particular embodiment, the removable tip **1500** comprises a distal end portion **1510** that is removable. In particular, the distal end portion **1510** is cut and removed from the removable tip **1500** once the retractor **202** is in position. The distal end portion **1510** may also be snapped off and removed. To aid in the removal of the distal end portion **1510**, the removable tip

1500 may comprise a weakened area configured to facilitate removal of the distal end portion **1510**. Once removed, a forceps or endo grasper E may be used to remove the distal end portion **1510** from the surgical site.

[0107] FIGS. 16A-16C illustrate another embodiment of a removable tip **1600** for use with retractor **102** and is similar to the embodiment discussed above in connection with FIGS. 4A-4D. Specifically, FIG. 16A illustrates a perspective partial cross-sectional view of exemplary retractor **102** attached to exemplary removable tip **1600**, FIG. 16B illustrates a perspective view of the distal end portion of the removable tip **1600**, and FIG. 16C illustrates a perspective view of removable tip **1600** disengaged from the exemplary retractor.

[0108] Referring to FIGS. 16A and 16B, removable tip **1600** includes proximal portion **1600a** and distal portion **1600b**. Removable tip **1600** is a substantially conical-shaped removable piece configured for attachment to distal portion **102b** of retractor **102** to improve retractor insertion, especially in the case of patients having large amounts of adipose tissue. As best seen in FIG. 16, distal portion **1600b** of removable tip **1600** comprises a flattened end portion having a reduced cross-section for ease of insertion and navigation through an incision and to prevent damaging organs and tissue. The reduced cross-section also facilitates grasping by a forceps or other device. Distal portion **1600b** may also include a opening for the attachment of a suture or pull wire.

[0109] Referring to FIG. 16A, proximal portion **1600a** of removable tip **1600** is substantially hollow and configured for receiving distal portion **102b** of retractor **102**, via, for example, a snap fit or other attachment means, including but not limited to a friction fit. In the particular embodiment illustrated, the distal portion **102b** of the retractor **102** comprises one or more grooves or indentations that are configured to receive one or more ridges or protrusion on the inside of removable tip **1600** to facilitate engagement between therebetween.

[0110] As illustrated in FIG. 16C, removable tip **1600** includes pull tab **1602** that when pulled, breaks removable tip **1600** at perforations **1604**, thereby causing removable tip **1600** to release its grip on retractor **102** such that removable tip **1600** may be removed. As explained above in connection with the embodiment of FIGS. 4C-4D, the pull tab **1602** can be grasped with a forceps or endo gripper, and then pulled away from removable tip **1600** to thereby cause perforations **1604** to break. Removable tip **1600** can then be disengaged from the retractor **102** and removed through an incision or port, or after the procedure is complete. Once removable tip **1600** is disengaged from retractor **102**, retractor **102** alone is of a sufficient length to perform its retracting functions.

[0111] FIG. 17 illustrates a method **1700** of use of an exemplary retractor-removable tip system, such as those illustrated herein and equivalents thereto. At block **1702**, a retractor is provided, such as those illustrated in FIGS. 1A-16C or equivalents thereto. At block **1704**, a removable tip is provided, such as those illustrated in FIGS. 1A-16C or equivalents thereto. At block **1706**, the removable tip is attached to the retractor forming an assembly. Attachment means include, but are not limited to a snap fit, friction fit, and a screw/threaded attachment. At block **1708** the assembly is inserted through an incision or a port. At block **1710**, the removable tip is disengaged from the retractor by a disengagement means, such as those illustrated in FIGS. 1A-16C, including but not limited to, pulling the removable tip distally from the retractor, snapping a distal portion of the tip breaking

the supporting neck, pulling a pull cord or pull tab causing the removable tip to break at perforations. At block 1712 the removable tip is removed from the incision or port, which may be the same incision or port illustrated at block 1608. The removable tip may be removed before or after removing the retractor from an incision or port. Means for removing the removable tip from an incision or a port include, but are not limited to, those illustrated in FIGS. 1A-16C and equivalents thereto, including but not limited to, back-threading the removable tip proximally along the retractor out through the incision or port, removing the retractor through a first incision or port and then removing the removable tip through the first incision or port, and removing the removable tip through a first incision or port and then removing the retractor through a second incision or port.

[0112] From the foregoing, the discovery of systems, apparatuses, and methods of removable tips for use in conjunction with medical instruments, including but not limited to, medical retractors in laparoscopic surgery improve the efficiency and navigation to the target anatomy while maintaining adequate exposure to the target anatomy. It can be seen that the embodiments illustrated and equivalents thereto as well as the methods of manufacturer may utilize machines or other resources, such as human beings, thereby reducing the time, labor, and resources required to manufacture the embodiments. Indeed, the discovery is not limited to the embodiments illustrated herein, and the principles and methods illustrated herein may be applied and configured to any retractor and equivalents.

[0113] Those of skill in the art will appreciate that embodiments not expressly illustrated herein may be practiced within the scope of the present discovery, including that features illustrated herein for different embodiments may be combined with each other and/or with currently-known or future-developed technologies while remaining within the scope of the claims presented here. It is therefore intended that the foregoing detailed description be regarded as illustrative rather than limiting. It is understood that the following claims, including all equivalents, are intended to define the spirit and scope of the discovery. Furthermore, the advantages illustrated above are not necessarily the only advantages of the discovery, and it is not necessarily expected that all of the illustrated advantages will be achieved with every embodiment of the discovery.

What is claimed is:

1. A removable tip comprising:
 - a substantially conical-shaped body comprising a proximal body portion and a distal body portion, wherein the proximal body portion comprises a substantially hollow portion and is configured for receiving a distal portion of a medical retractor, and wherein the distal body portion is atraumatic.
2. The removable tip of claim 1 further comprising a disengagement means for disengagement of the removable tip from a medical retractor.
3. The removable tip of claim 2, wherein the disengagement means comprises at least one of a distally-pullable removable tip, a snap point to break a supporting neck of the removable tip, a pull cord to break a perforation of the removable tip, or a pull tab to break a perforation of the removable tip.
4. The removable tip of claim 1 further comprising:
 - a supporting neck disposed between the proximal body portion and the distal body portion;

- a snap point disposed adjacent to the supporting neck, wherein the snap point is configured to break a portion of the supporting neck when a force is applied to the distal body portion away from the snap point.

5. The removable tip of claim 1 further comprising:
 - a pull cord attached to the substantially conical-shaped body; and

- one or more perforations disposed on the substantially conical-shaped body and near to the pull cord configured to break when the pull cord is pulled in a direction proximal to the substantially conical-shaped body.

6. The removable tip of claim 5, wherein the perforations are disposed spirally about the substantially conical-shaped body.

7. The removable tip of claim 5, wherein the pull cord further comprises a retaining ring disposed at a proximal portion of the pull cord.

8. The removable tip of claim 1 further comprising:
 - a pull tab attached to the substantially conical-shaped body; and

- one or more perforations disposed on the substantially conical-shaped body and adjacent to the pull tab configured to break when the pull tab is pulled in a direction away from the substantially conical-shaped body.

9. A medical retractor system comprising:
 - a removable tip comprising:
 - a substantially conical-shaped body comprising a proximal body portion and a distal body portion, wherein the proximal body portion comprises a substantially hollow portion and is configured for receiving a distal portion of a medical retractor, and wherein the distal body portion is atraumatic;
 - a disengagement means in communication with the substantially conical-shaped body configured to disengage the substantially conical-shaped body from a distal portion of a medical retractor;
 - a medical retractor having a proximal portion and a distal portion, wherein the distal portion is connected to the removable tip.

- a substantially conical-shaped body comprising a proximal body portion and a distal body portion, wherein the proximal body portion comprises a substantially hollow portion and is configured for receiving a distal portion of a medical retractor, and wherein the distal body portion is atraumatic;

- a disengagement means in communication with the substantially conical-shaped body configured to disengage the substantially conical-shaped body from a distal portion of a medical retractor;

- a medical retractor having a proximal portion and a distal portion, wherein the distal portion is connected to the removable tip.

10. The medical retractor system of claim 9, wherein the disengagement means comprises at least one of a distally-pullable removable tip, a snap point to break a supporting neck of the removable tip, a pull cord to break a perforation of the removable tip, or a pull tab to break a perforation of the removable tip.

11. The medical retractor system of claim 9, wherein the removable tip further comprises:
 - a supporting neck disposed between the proximal body portion and the distal body portion;

- a snap point disposed adjacent to the supporting neck, wherein the snap point is configured to break a portion of the supporting neck when a force is applied to the distal body portion away from the snap point thereby releasing the removable tip from the distal portion of the medical retractor.

- a snap point disposed adjacent to the supporting neck, wherein the snap point is configured to break a portion of the supporting neck when a force is applied to the distal body portion away from the snap point thereby releasing the removable tip from the distal portion of the medical retractor.

12. The medical retractor system of claim 9, wherein the removable tip further comprises:
 - a pull cord attached to the substantially conical-shaped body; and

- one or more perforations disposed on the substantially conical-shaped body and near to the pull cord configured to break when the pull cord is pulled in a direction proximal to the substantially conical-shaped body

thereby releasing the removable tip from the distal portion of the medical retractor.

13. The medical retractor system of claim **12**, wherein the perforations are disposed spirally about the substantially conical-shaped body.

14. The removable tip of claim **12**, wherein the pull cord further comprises a retaining ring disposed at a proximal portion of the pull cord.

15. The medical retractor system of claim **9**, wherein the removable tip further comprises:

a pull tab attached to the substantially conical-shaped body; and

one or more perforations disposed on the substantially conical-shaped body and adjacent to the pull tab configured to break when the pull tab is pulled in a direction away from the substantially conical-shaped body thereby releasing the removable tip from the distal portion of the medical retractor.

16. A method for using a medical retractor system comprising:

providing a medical retractor comprising a proximal portion and a distal portion; and

providing a removable tip comprising a substantially conical-shaped body comprising a proximal body portion and a distal body portion, wherein the proximal body portion comprises a substantially hollow portion and is configured for receiving the distal portion of the medical retractor, and wherein the distal body portion is atraumatic.

17. The method of claim **16**, further comprising connecting the distal portion of the medical retractor to the proximal body portion of the substantially conical-shaped body forming an assembly.

18. The method of claim **17**, further comprising inserting the assembly through an incision or port.

19. The method of claim **18**, further comprising disengaging the removable tip from the distal portion of the medical retractor.

20. The method of claim **19**, further comprising removing the removable tip through an incision or port.

* * * * *

专利名称(译)	可拆卸医用牵开器尖端		
公开(公告)号	US20130317305A1	公开(公告)日	2013-11-28
申请号	US13/783570	申请日	2013-03-04
[标]申请(专利权)人(译)	库克医学技术有限责任公司		
申请(专利权)人(译)	库克医疗技术有限责任公司		
当前申请(专利权)人(译)	库克医疗技术有限责任公司		
[标]发明人	STEVENSON ANDREW R L BURLEIGH TIFFANY FORD MICHAEL WILLIAM GUTIERREZ CAROLINA JUNGER MICHAEL CARL MACNAUGHTAN JAMES VIZCAY WILSON CAITLIN		
发明人	STEVENSON, ANDREW R.L. BURLEIGH, TIFFANY FORD, MICHAEL WILLIAM GUTIERREZ, CAROLINA JUNGER, MICHAEL CARL MACNAUGHTAN, JAMES VIZCAY-WILSON, CAITLIN		
IPC分类号	A61B17/02		
CPC分类号	A61B17/0218 A61B17/3415 A61B2017/00296 A61B2017/00336 A61B2017/00473 A61B2017/00557 A61B2017/3454 A61B2090/037		
优先权	61/651803 2012-05-25 US		
外部链接	Espacenet USPTO		

摘要(译)

所示的示例性实施例提供了在腹腔镜手术中与医疗牵开器一起使用的可移除尖端的系统，方法和装置的发现，其提供许多益处，包括但不限于，提高效率和导航到目标解剖结构，同时保持足够的暴露于目标解剖学。

