



US 20060106414A1

(19) **United States**

(12) **Patent Application Publication**
Fogarty et al.

(10) **Pub. No.: US 2006/0106414 A1**

(43) **Pub. Date: May 18, 2006**

(54) **EXTRALUMINAL BALLOON DISSECTION**

(75) Inventors: **Thomas J. Fogarty**, Portola Valley, CA (US); **George D. Hermann**, Portola Valley, CA (US); **Jan M. Echeverry**, San Jose (CA); **Kenneth H. Mollenauer**, Los Gatos, CA (US)

Jun. 4, 2001, now Pat. No. 6,447,529, which is a continuation of application No. 09/444,220, filed on Nov. 19, 1999, now abandoned, which is a continuation of application No. 09/326,867, filed on Jun. 7, 1999, now abandoned, which is a continuation of application No. 09/206,811, filed on Dec. 7, 1998, now Pat. No. 5,968,066, which is a continuation of application No. 08/824,676, filed on Mar. 26, 1997, now Pat. No. 5,814,060, which is a continuation of application No. 08/631,221, filed on Apr. 11, 1996, now Pat. No. 5,690,668, which is a continuation-in-part of application No. 08/267,484, filed on Jun. 29, 1994, now Pat. No. 5,601,589.

Correspondence Address:
UNITED STATES SURGICAL,
A DIVISION OF TYCO HEALTHCARE
GROUP LP
195 MCDERMOTT ROAD
NORTH HAVEN, CT 06473 (US)

Publication Classification

(73) Assignee: **General Surgical Innovations, Inc.**

(21) Appl. No.: **11/273,508**

(51) **Int. Cl.**
A61M 29/00 (2006.01)

(22) Filed: **Nov. 14, 2005**

(52) **U.S. Cl.** **606/192**

Related U.S. Application Data

(57) **ABSTRACT**

(63) Continuation of application No. 10/790,378, filed on Mar. 1, 2004, now Pat. No. 6,989,018, which is a continuation of application No. 10/238,108, filed on Sep. 9, 2002, now Pat. No. 6,764,497, which is a continuation of application No. 09/873,930, filed on

The present invention provides balloon dissection apparatus and methods of use in which an elongate balloon is utilized to dissect along a region that follows a naturally existing path alongside a vessel or structure, such as an entry, a vein, a lymphatic vessel, the tracheas, the esophagus, or even a nerve bundle.

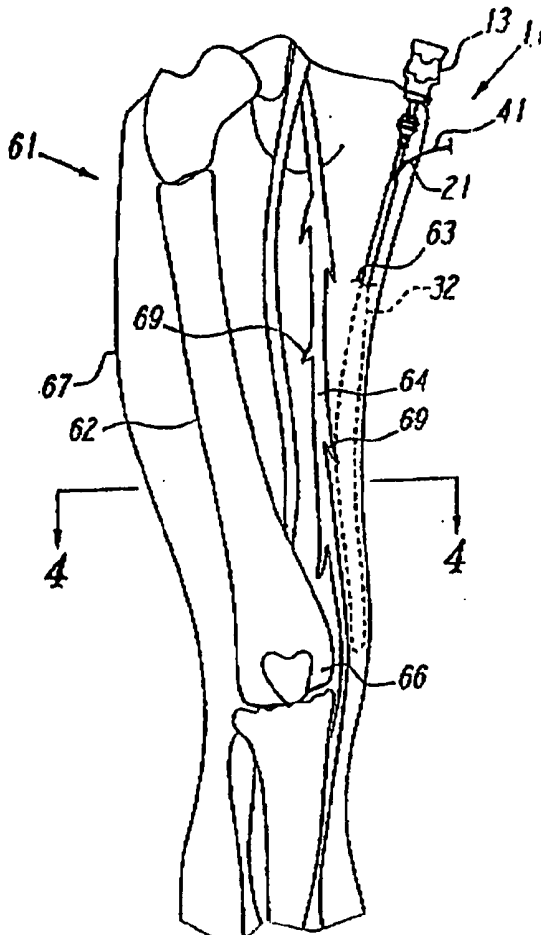

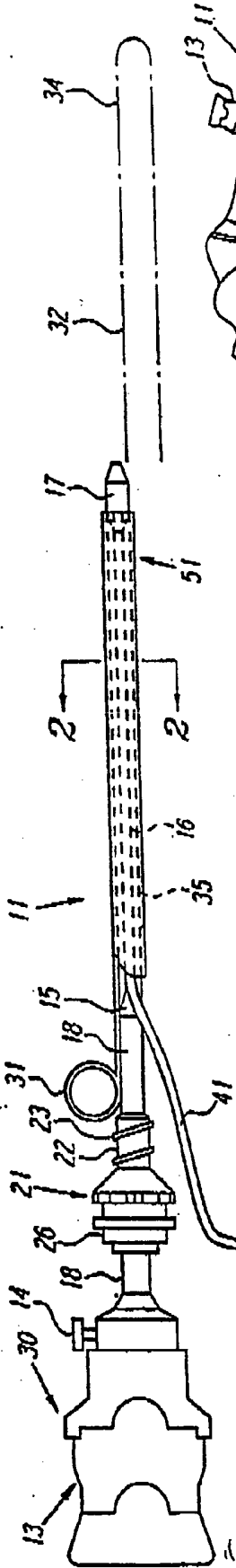

FIG. 1

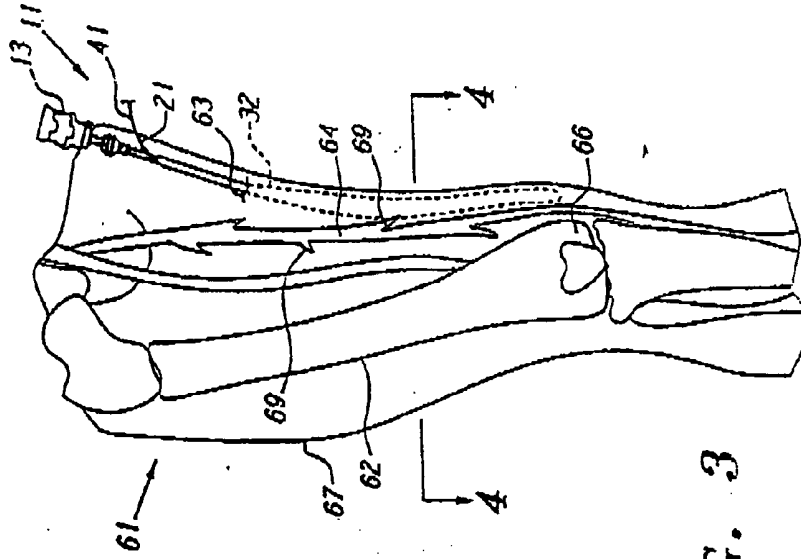

FIG. 3

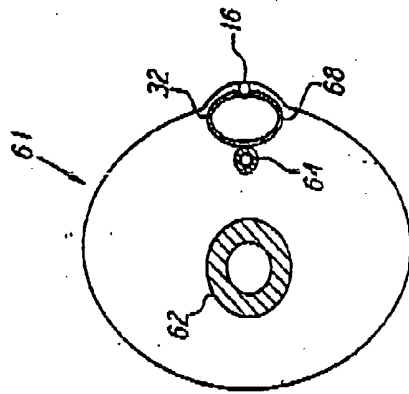

FIG. 4

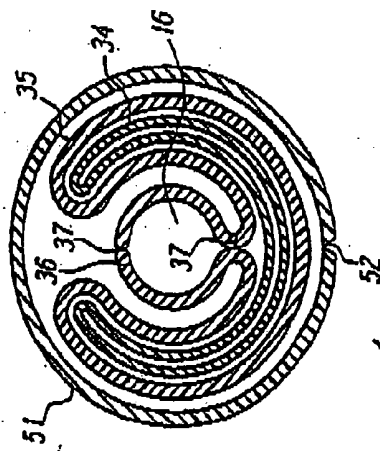
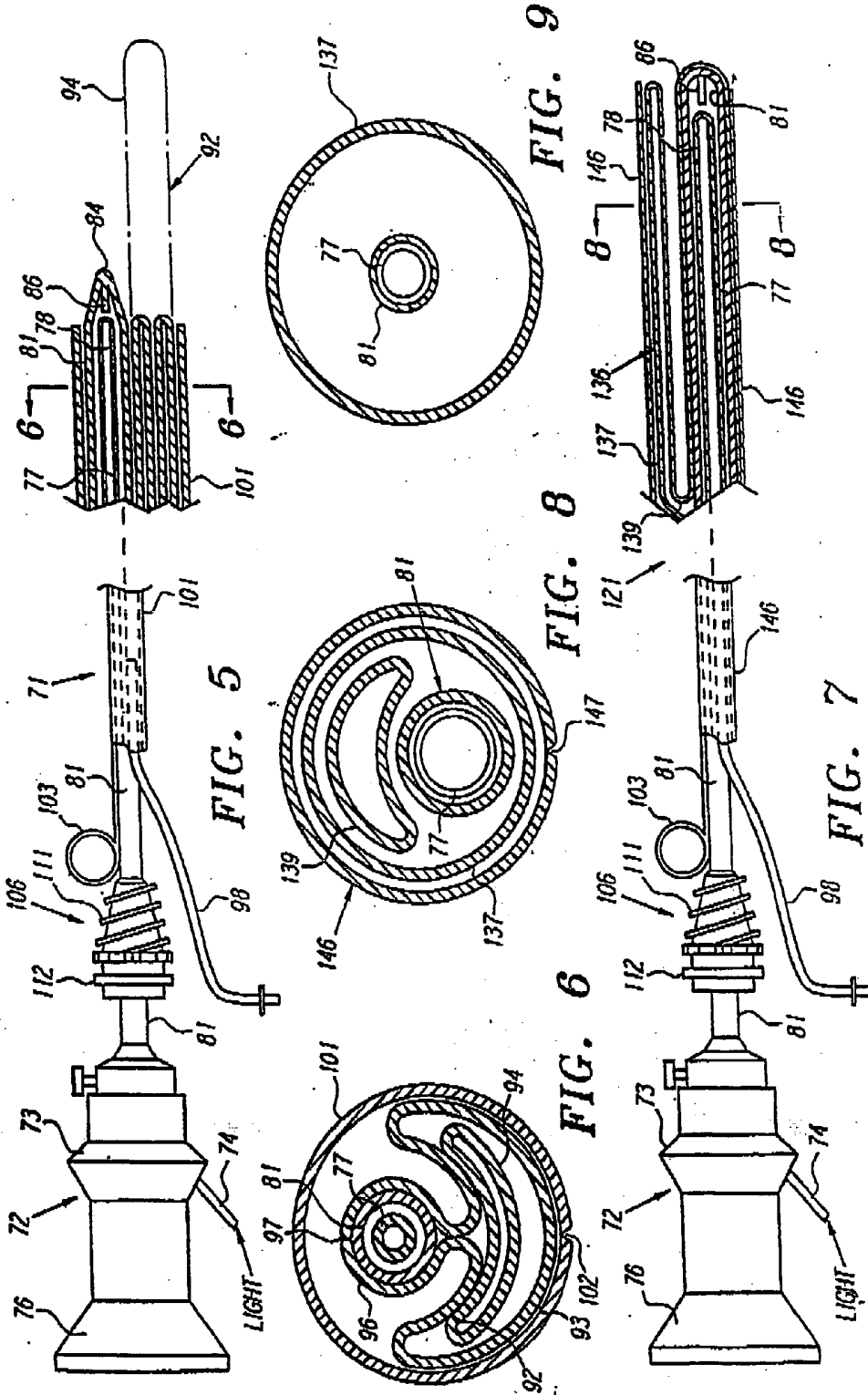

FIG. 2



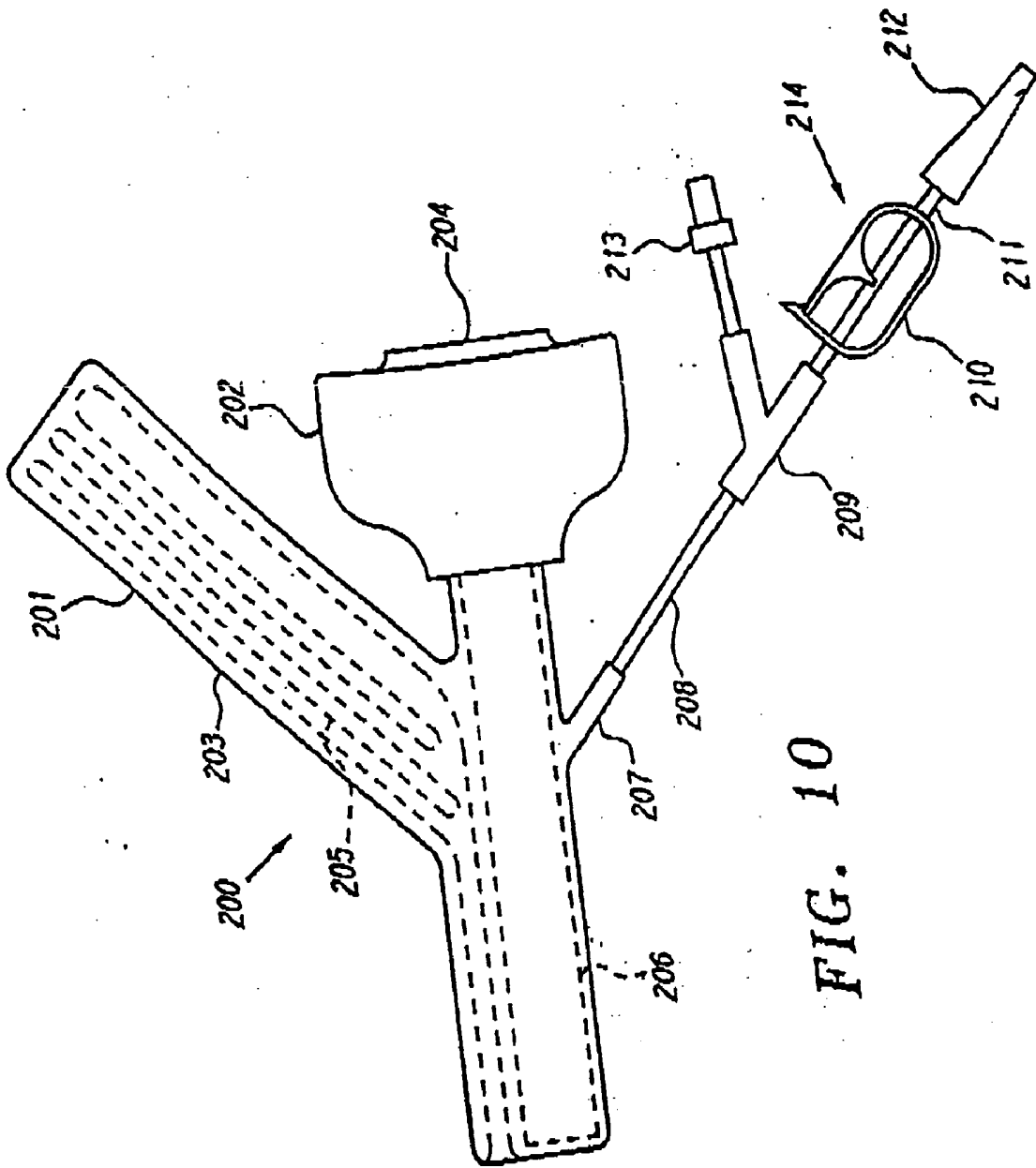

FIG. 10

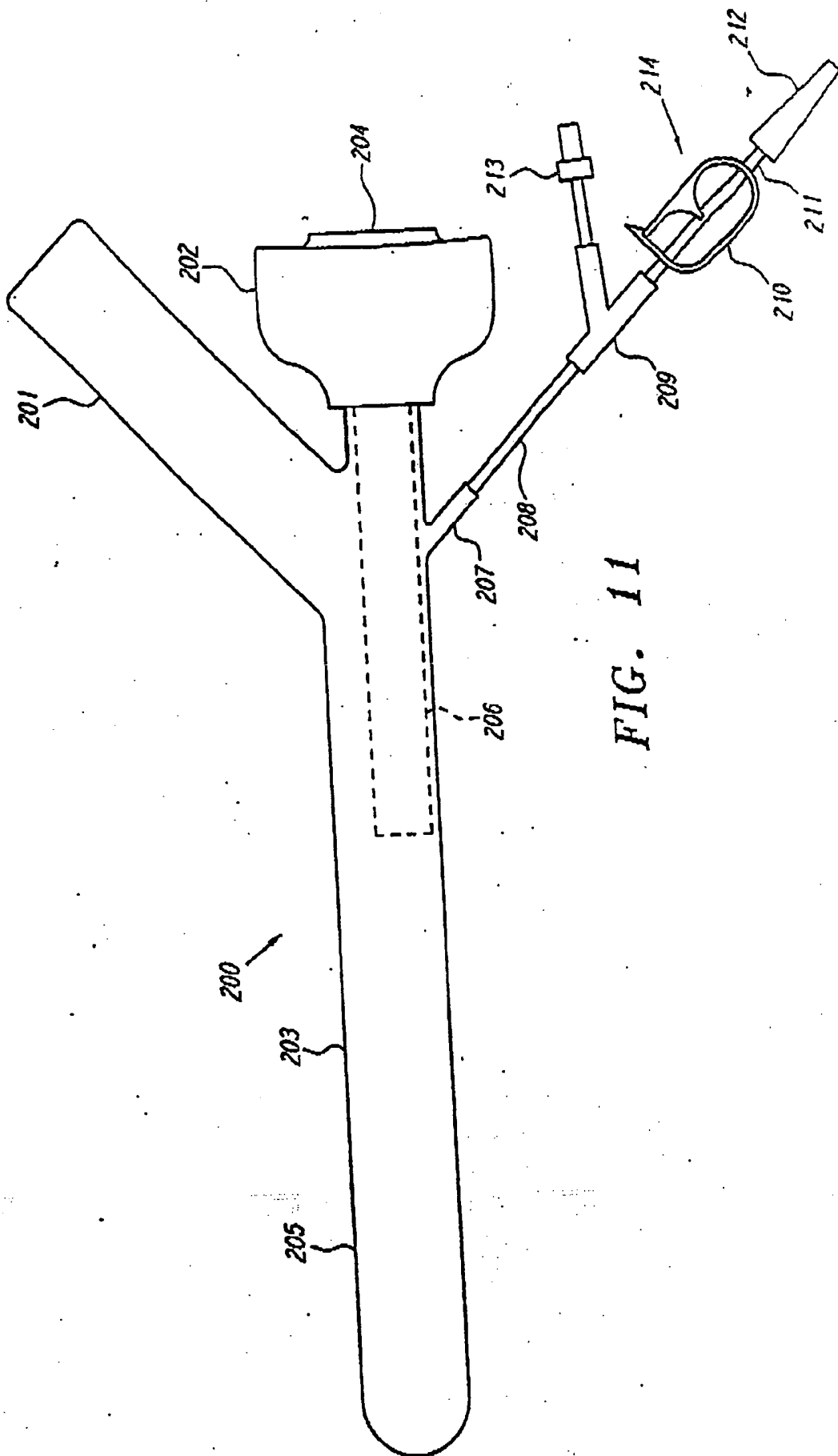

FIG. 11

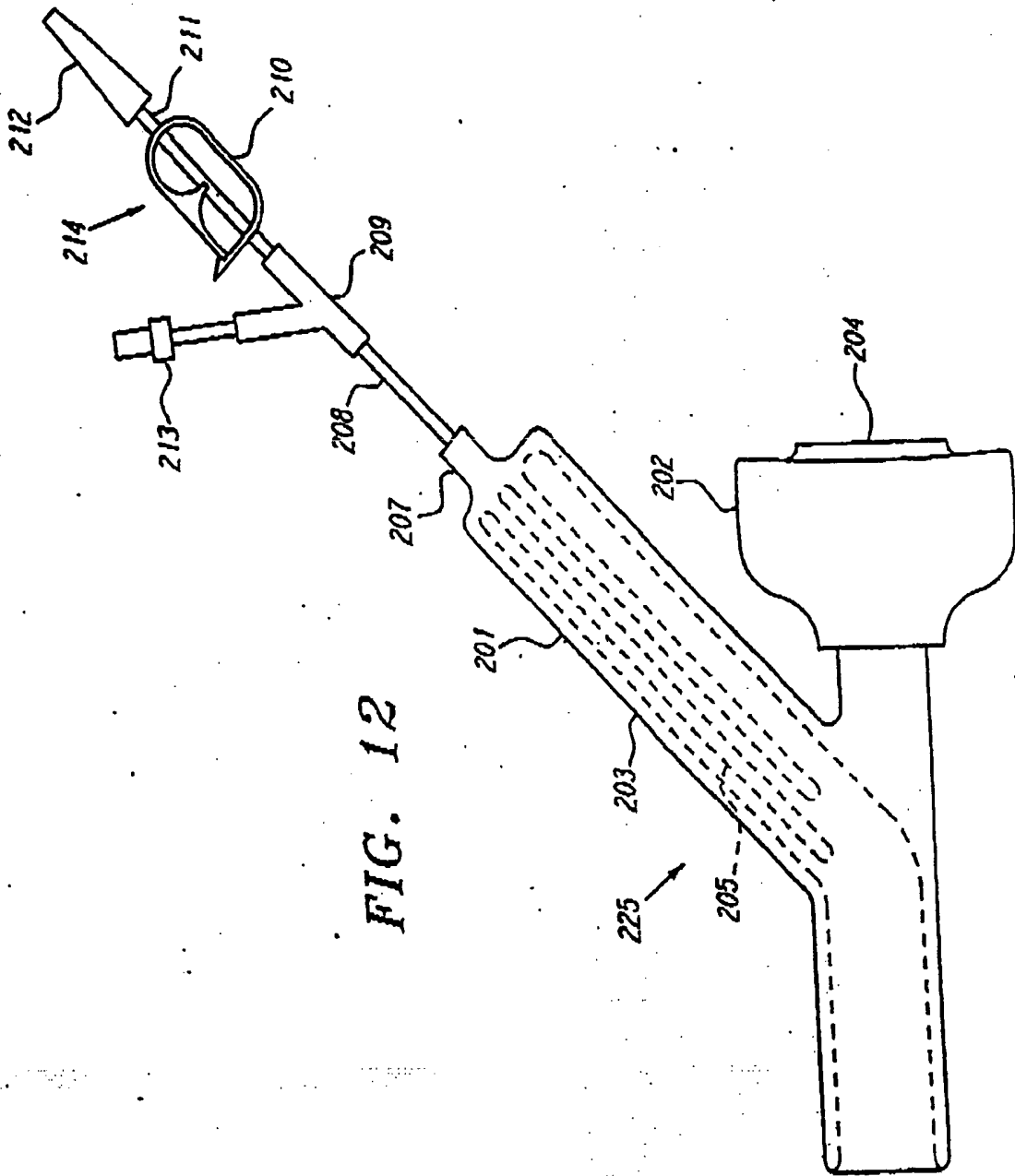
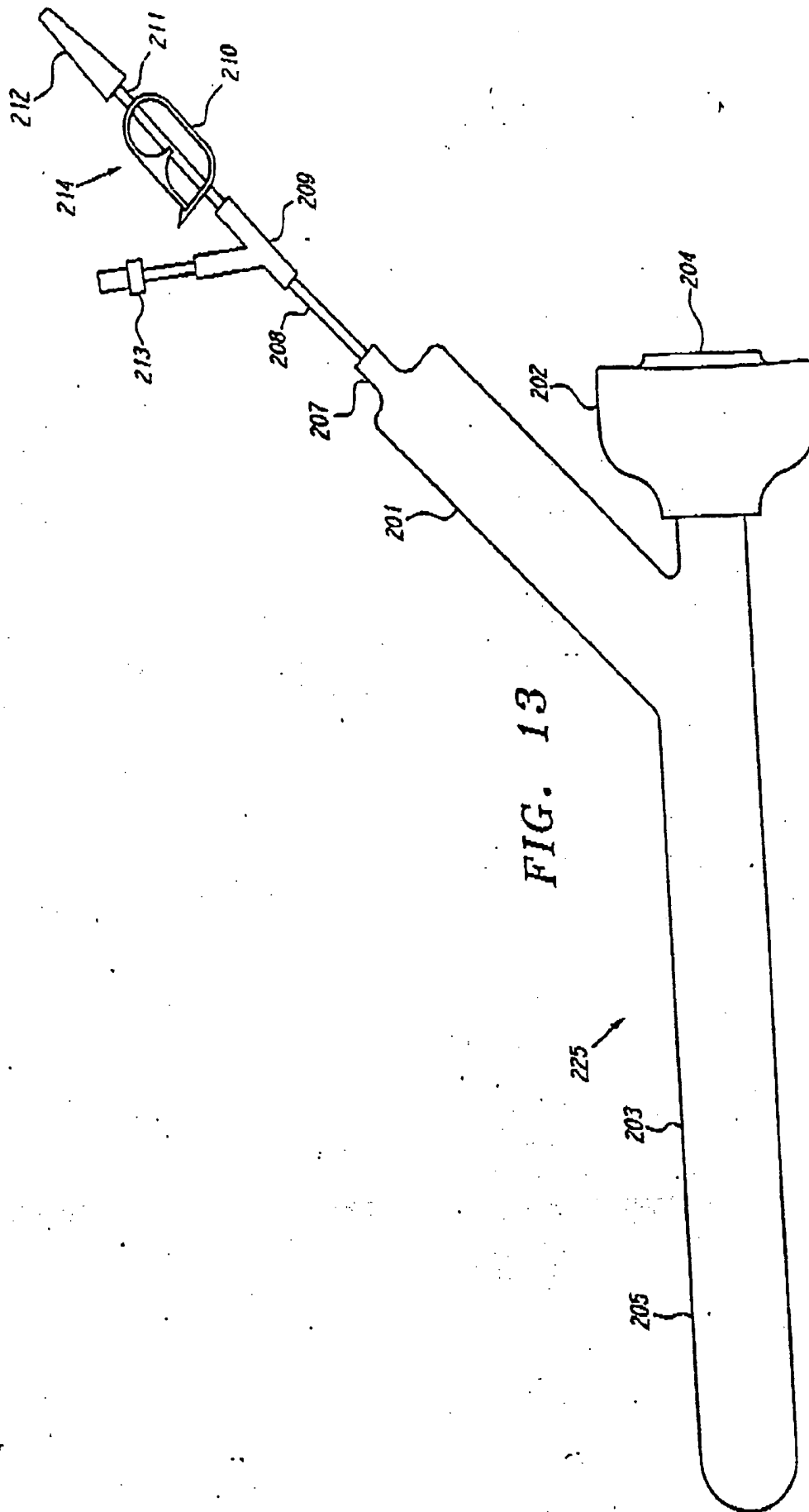

FIG. 12



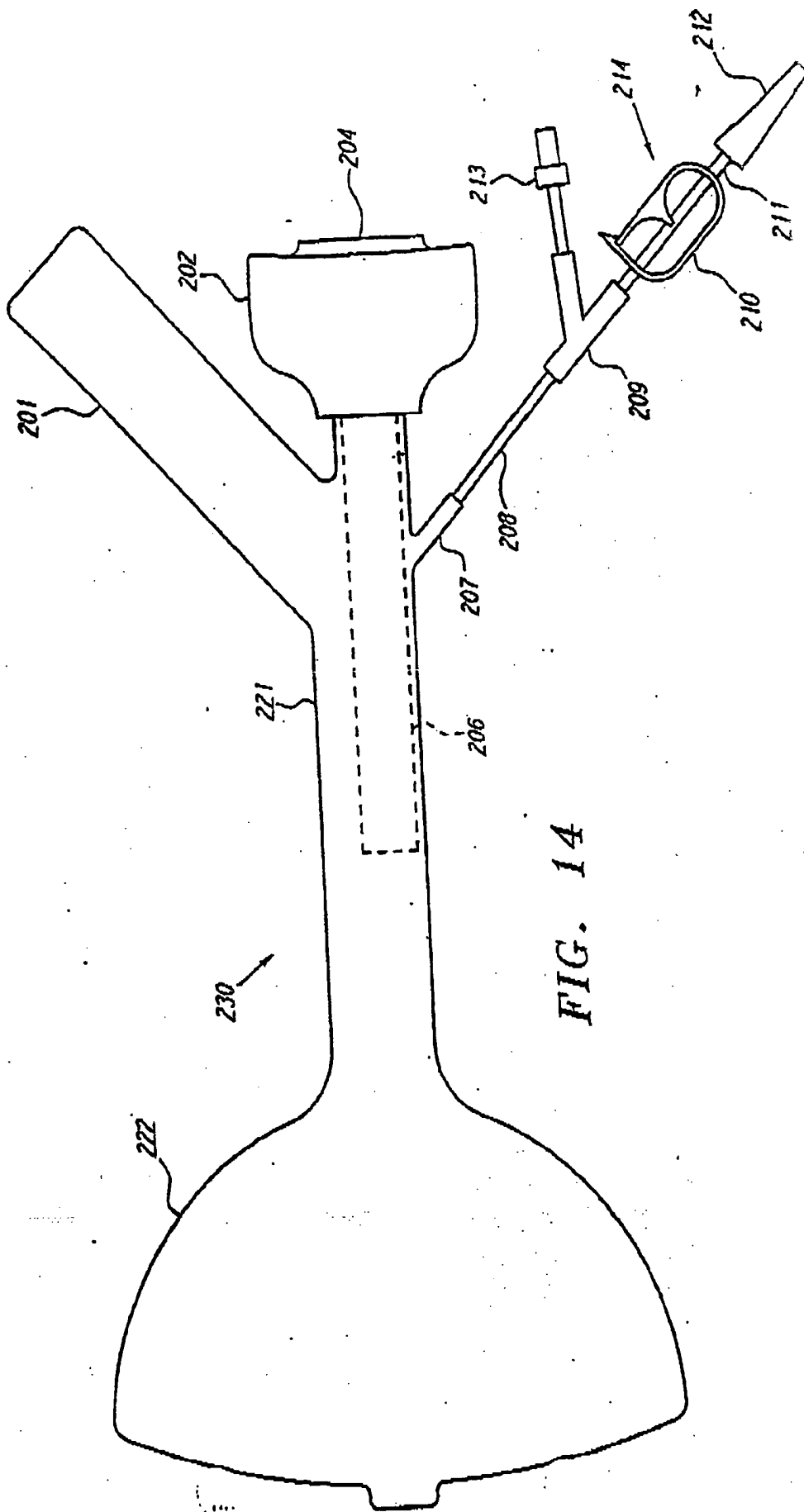

FIG. 14

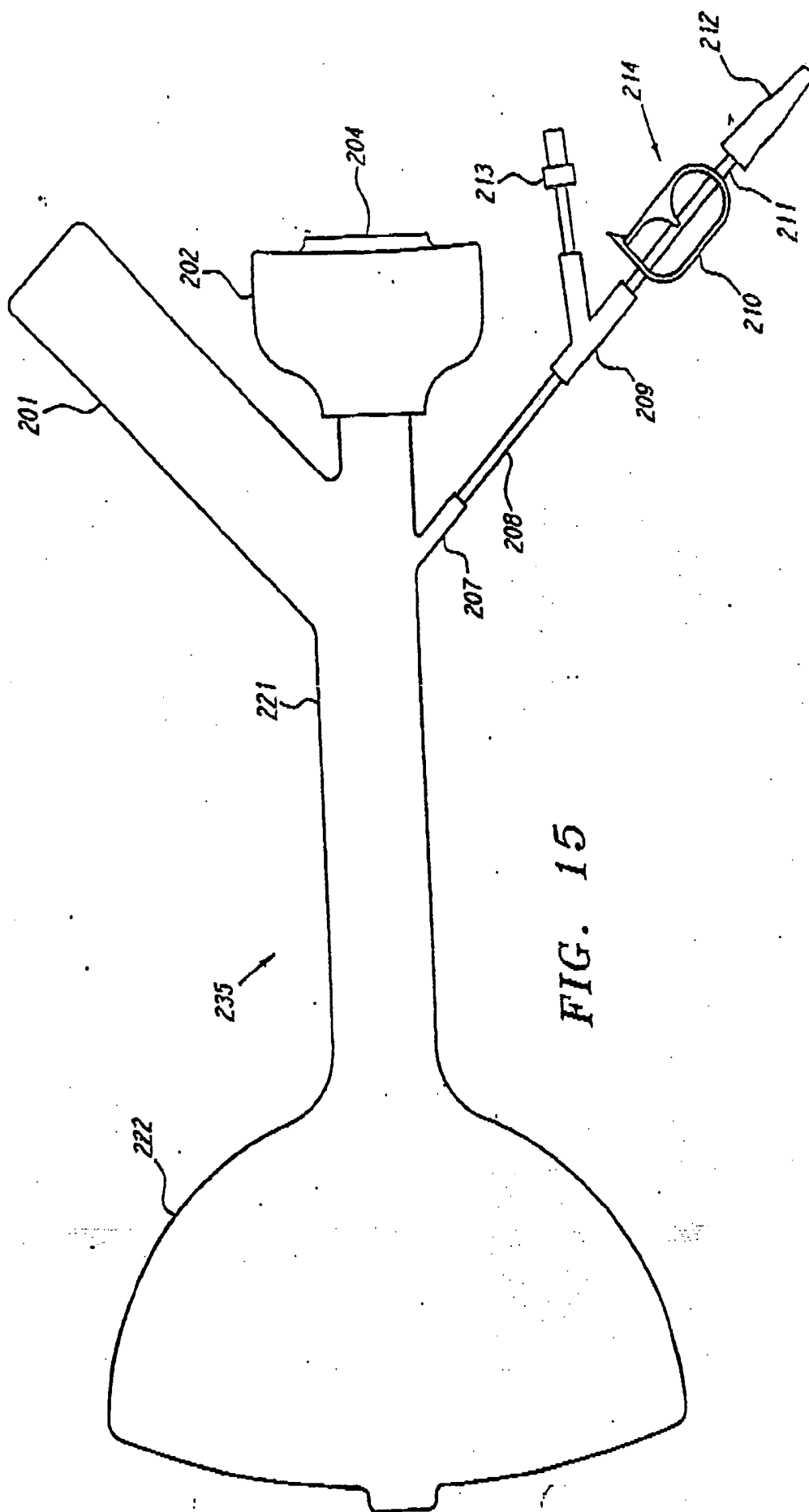

FIG. 15

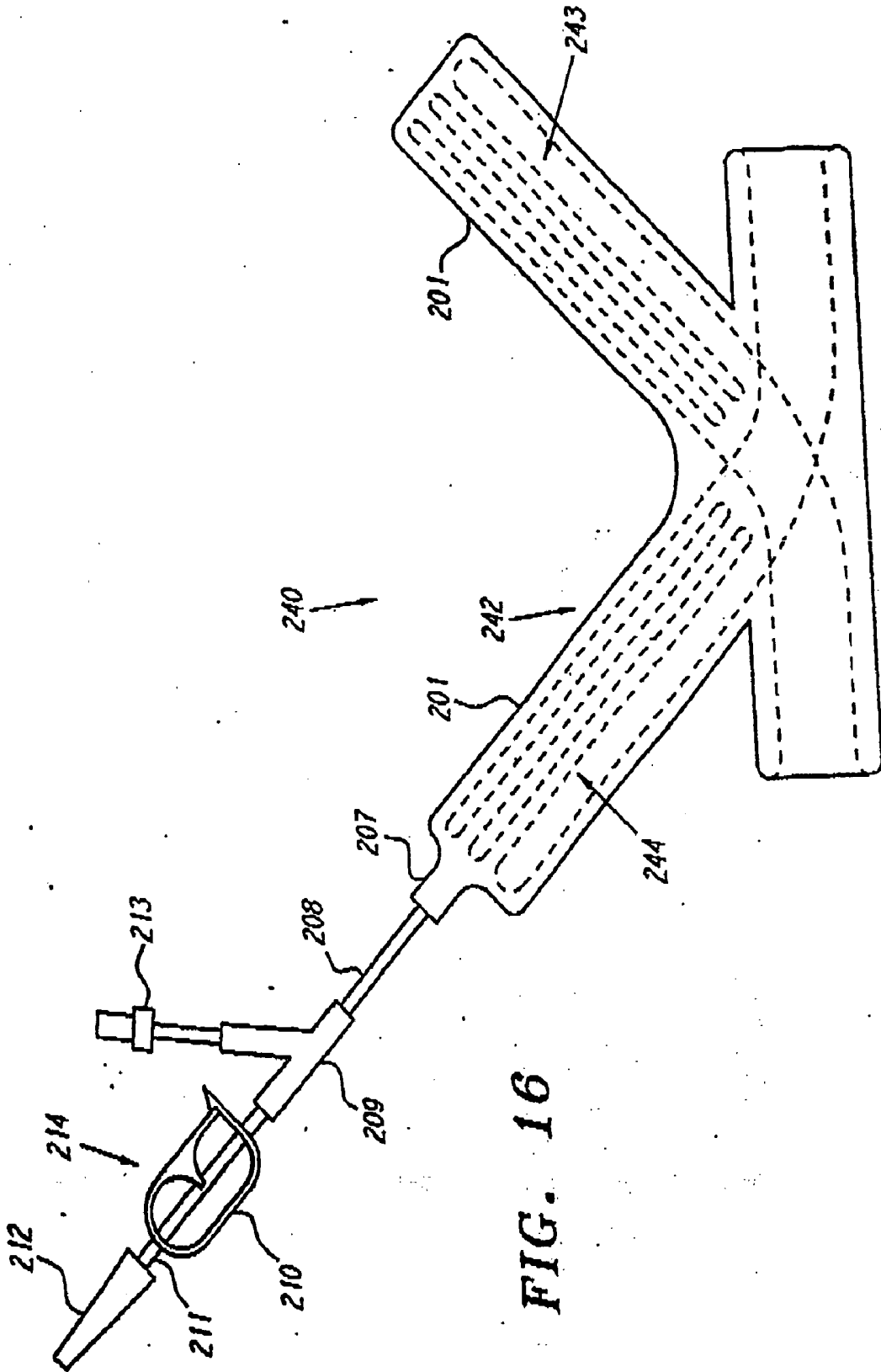
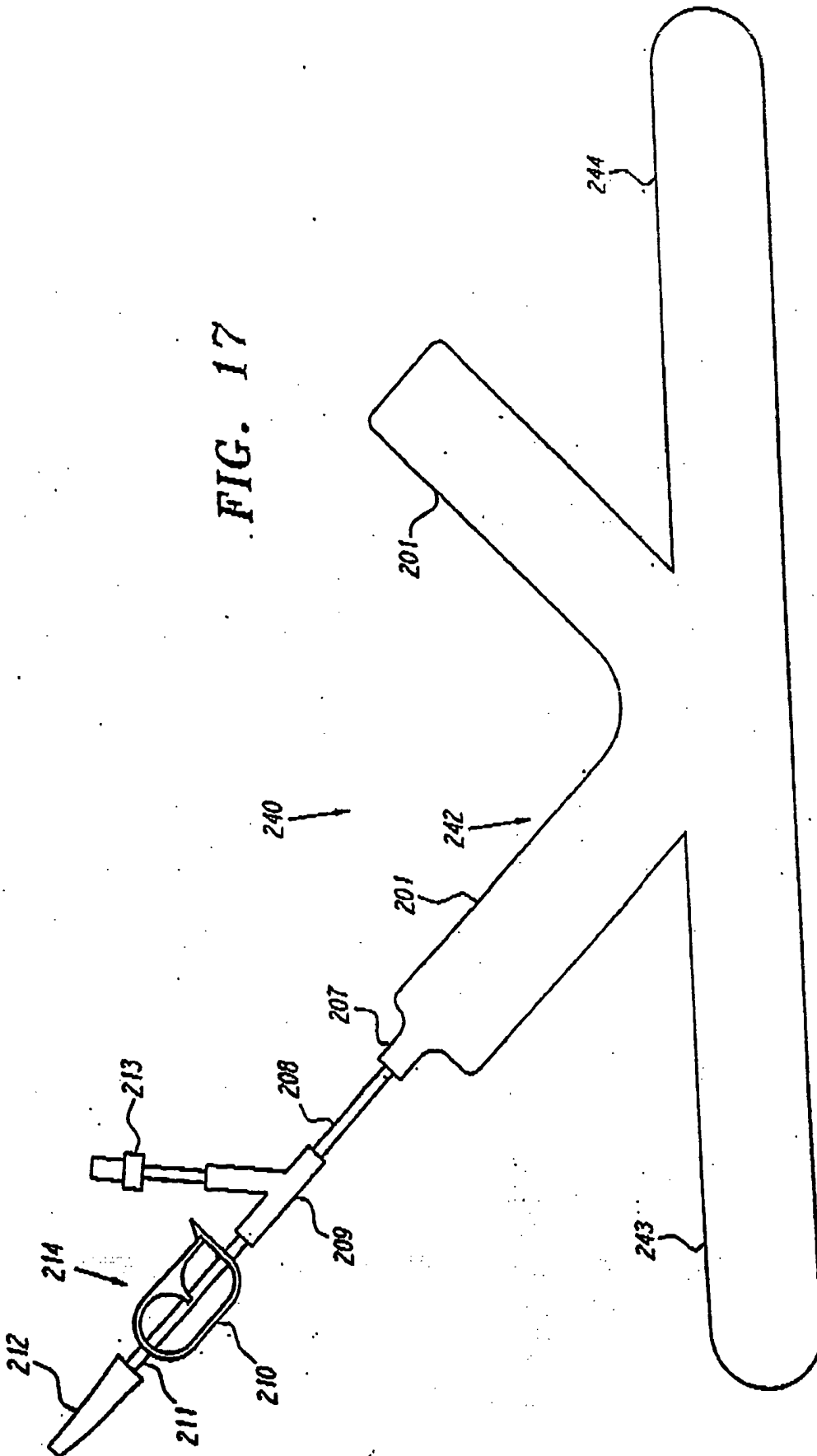
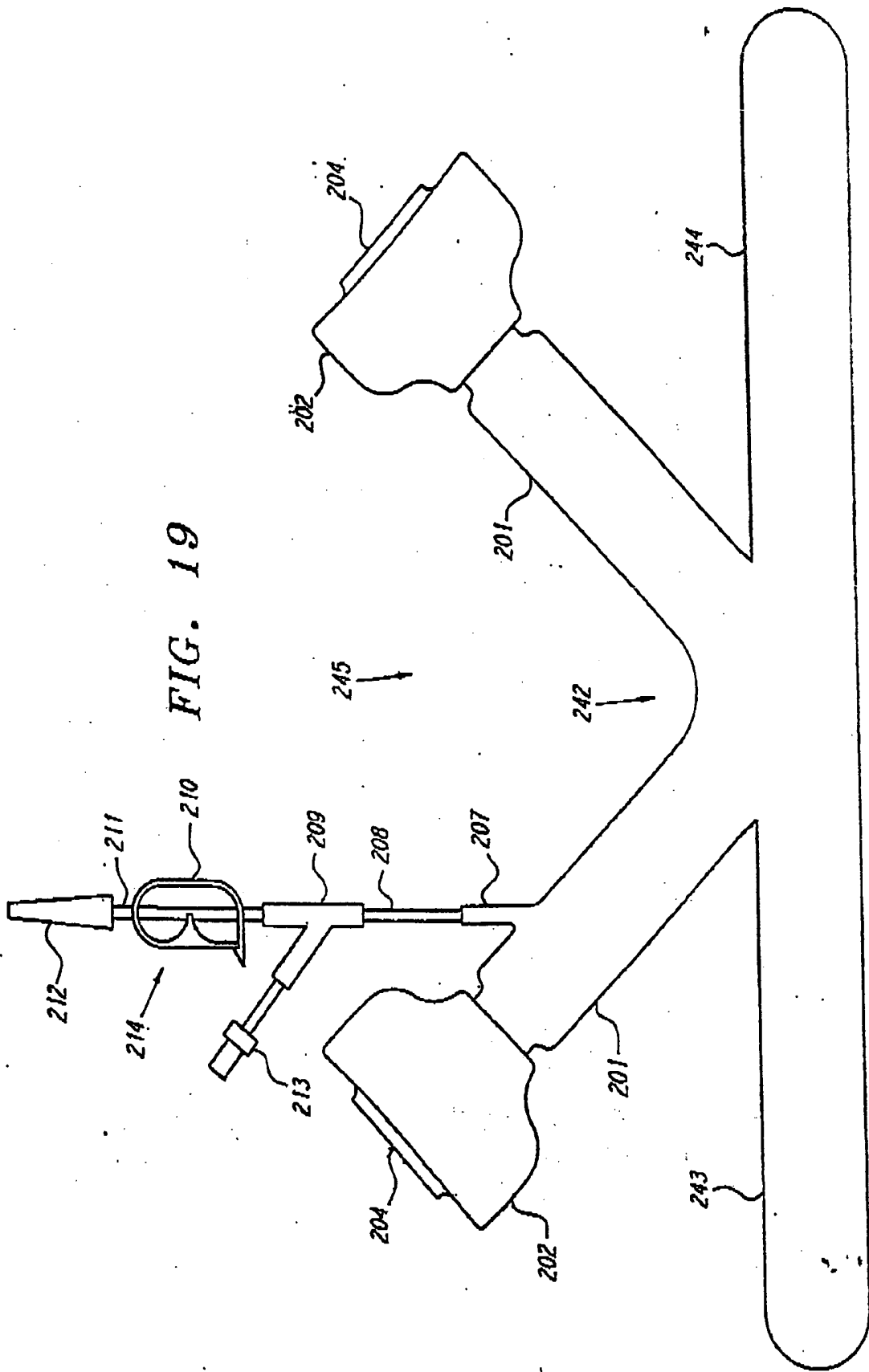

FIG. 16

FIG. 17





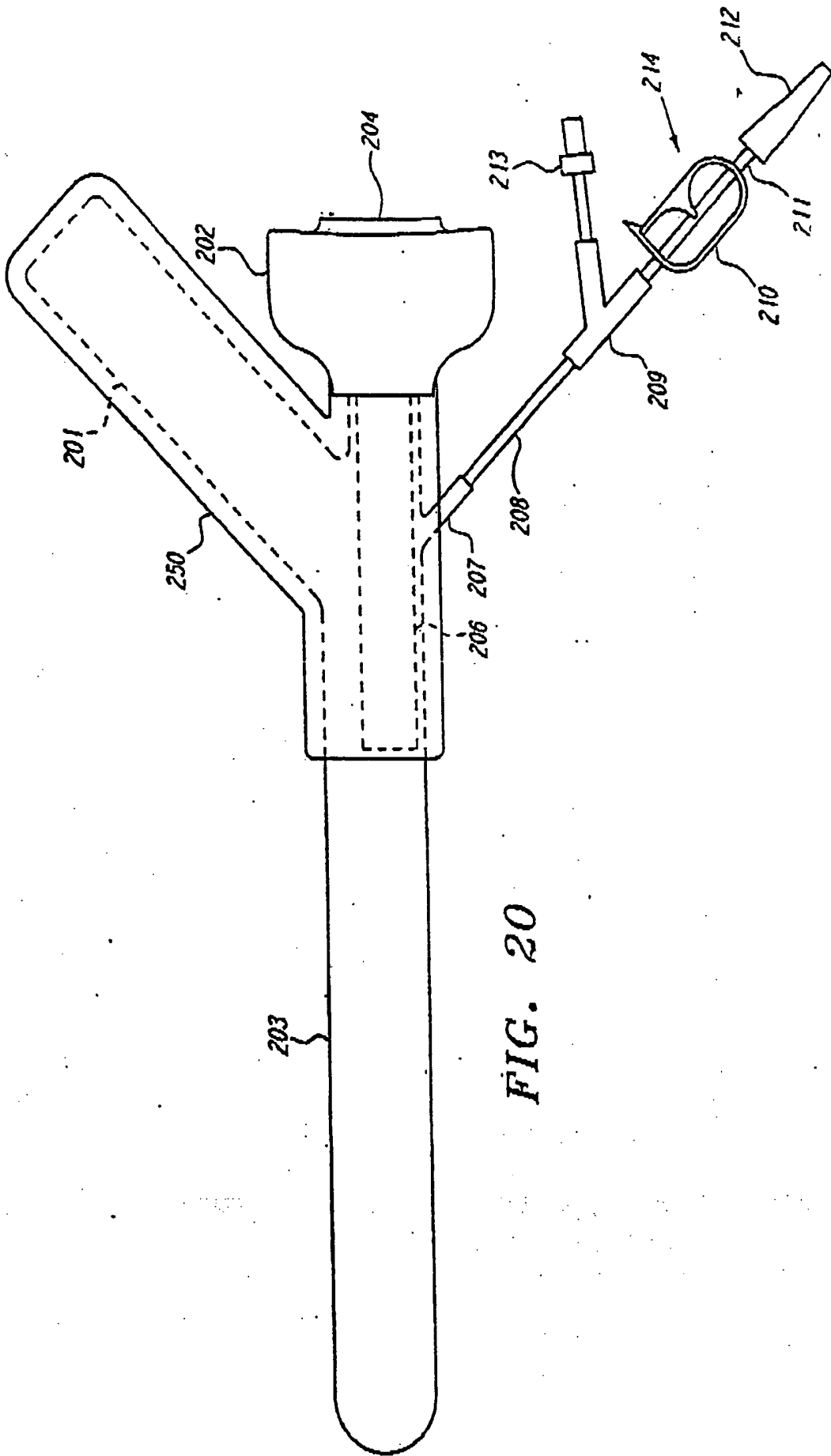

FIG. 20

EXTRALUMINAL BALLOON DISSECTION

[0001] This application is a continuation on of co-pending U.S. application Ser. No. 09/039,548; filed on Mar. 16, 1998; which is a continuation of U.S. pending application Ser. No. 08/824,676, filed on Mar. 26, 1997, which is a continuation of U.S. application Ser. No. 08/631,221, filed on Jun. 29, 1994, now U.S. Pat. No. 5,690,668, which is a continuation-in-part of U.S. application Ser. No. 08/267,484, filed on Jun. 29, 1994, now U.S. Pat. No. 5,601,589, the disclosures of which hereby incorporated by reference in their entirety.

FIELD OF THE INVENTION

[0002] The present invention relates generally to the field of extraluminal balloon dissection. More particularly, the present invention relates to vascular methods and apparatus which can be used for creating an anatomic working space alongside an elongate structure, such as a vessel or nerve, for example.

BACKGROUND OF THE INVENTION

[0003] In commonly assigned copending application Ser. No. 07/893,988, filed on Jun. 2, 1992, apparatus and methods are disclosed for developing an anatomic working space for laparoscopic procedures using balloon dissection. In commonly assigned copending application Ser. No. 08/570,766, filed on Dec. 12, 1995, further improvements to the apparatus and methods disclosed in application Ser. No. 07/893,988 were disclosed. The disclosure of each of these prior applications is hereby incorporated by reference in its entirety. The apparatus and methods disclosed in the referenced prior applications include balloon dissection apparatus with relatively large surface balloons which expand laterally and are not particularly well suited for surgical procedures on elongated structures. There is therefore a need for new and improved balloon dissection apparatus and associated methods of use for dissecting or creating space alongside elongate structures in the body.

SUMMARY OF THE INVENTION

[0004] The present invention provides balloon dissection apparatus and methods of use in which an elongate balloon is utilized to dissect along a region that follows a naturally existing path alongside a vessel or structure, such as an artery, a vein, a lymphatic vessel, the trachea, the esophagus, or even a nerve bundle.

[0005] The balloon dissection apparatus for use in extraluminal balloon dissection as described herein may utilize an elongate balloon with a tunneling shaft assembly of the types described in any one of copending U.S. application Ser. Nos. 07/893,988, 08/124,283, 08/267,488, 08/388,233, 08/403,012, or 08/570,766, the disclosure of each of which is hereby incorporated by reference in its entirety. U.S. Pat. No. 4,271,839 to Fogarty et al. which discloses a balloon catheter with an inverted balloon is also expressly incorporated by reference herein.

[0006] In a preferred embodiment, the deflated elongate balloon has at least a part of its distal extremity folded inwardly to shorten its predeployment length. The distal portion of the elongate balloon may be inverted into the proximal portion end folded inwardly to provide a balloon having a folded length of roughly one-half the length of the

fully distended balloon. Additional inward folds may be provided to further shorten the balloon.

[0007] In another preferred embodiment a thumb-shaped balloon reservoir may be provided as an integral portion of the elongate balloon. The balloon reservoir generally remains outside the body and serves to store the distal portion of the inverted, folded balloon prior to deployment. By storing the bulk of the deflated balloon outside of the body in the reservoir a longer balloon can be utilized. Provision is made for laparoscopic observation.

[0008] A bi-directionally expanding balloon is also disclosed which is useful when anatomical obstructions would cause a balloon expanding in one direction only to be blocked. The bi-directional balloon may be utilized either with or without the aid of laparoscopic observation.

[0009] In a preferred method of performing extraluminal balloon dissection, a deflated and folded elongate balloon is inserted into an incision in the body adjacent the elongate structure aided by a laparoscope, a finger, or other tunneling member. The folded elongate balloon is then optionally bluntly advanced alongside the elongate structure until a region where it is desired to perform balloon dissection is reached. As the balloon is advanced alongside the elongate structure a laparoscope may be utilized to observe beyond the distal end of the balloon, either from within or alongside the balloon. An inflation medium is then introduced into the balloon to cause the balloon to evert and propagate distally alongside the elongate structure to dissect the structure along a natural tissue plane. The laparoscope may also be used to observe dissection as the balloon propagates alongside the structure if provided. After the structure has been dissected the balloon may be deflated and withdrawn through the incision. The anatomic operating space alongside the vessel created by the dissecting balloon may be insufflated and a surgical procedure performed.

BRIEF DESCRIPTION OF THE DRAWINGS

[0010] Reference is made to the accompanying drawings, when like reference numerals are used on like parts and where illustrative embodiments of the invention are shown from one of ordinary skill in the art will appreciate novel features and advantages of the present invention.

[0011] In the drawings:

[0012] **FIG. 1** is a side elevational view of an extraluminal balloon dissection apparatus incorporating aspects of the present invention.

[0013] **FIG. 2** is a cross-sectional view taken along line 2-2 in **FIG. 1**.

[0014] **FIG. 3** is a view of the human leg illustrating the present invention being used to create an anatomic working space alongside a saphenous vein during a saphenous vein bypass procedure.

[0015] **FIG. 4** is a cross sectional view taken along line 4-4 in **FIG. 3**.

[0016] **FIG. 5** is a side elevational view of another embodiment of an extraluminal balloon dissection apparatus according to the present invention.

[0017] **FIG. 6** is a cross sectional view taken along lines 6-6 in **FIG. 5**.

[0018] FIG. 7 is a side elevational view of yet another embodiment of an apparatus according to the present invention.

[0019] FIG. 8 is a cross sectional view taken along line 8-8 in FIG. 7.

[0020] FIG. 9 is a cross sectional view showing the balloon of FIG. 8 after it has been inflated.

[0021] FIG. 10 is a plan view of another embodiment of an extraluminal balloon dissection apparatus according to the invention illustrating the folding and storage of the elongate balloon within a thumb-shaped balloon reservoir.

[0022] FIG. 11 is a plain view of the apparatus of FIG. 10 showing the elongate balloon fully distended after inflation.

[0023] FIG. 12 is plan view of another embodiment of an extraluminal balloon dissection apparatus according to the invention utilizing an elongate balloon and a thumb-shaped balloon reservoir.

[0024] FIG. 13 is a plan view of the apparatus of FIG. 12 showing the elongate balloon fully distend after inflation.

[0025] FIG. 14 is a plan view of another embodiment of an extraluminal balloon dissection apparatus according to the invention utilizing a balloon reservoir and a bulb-shaped balloon.

[0026] FIG. 15 is a plan view of yet another embodiment of an extraluminal balloon dissection apparatus according to the invention utilizing a balloon reservoir and a bulb shaped balloon.

[0027] FIG. 16 is a side elevational view of another embodiment of an extraluminal balloon dissection apparatus according to the invention having two balloon reservoirs and a bi-directionally expanding elongate balloon.

[0028] FIG. 17 is a side elevational view of the FIG. 16 embodiment illustrating the apparatus after the bi-directionally expanding balloon has been inflated and is fully distended.

[0029] FIG. 18 is a side elevational view of another embodiment of an extraluminal balloon dissection apparatus according to the invention which is substantially similar to the embodiment of FIG. 16 which provides for laparoscopic observation.

[0030] FIG. 19 is a side elevational view of the FIG. 18 embodiment after the bi-directionally expanding balloon has been inflated and is fully distended.

[0031] FIG. 20 is a plan view of a balloon reinforcing sleeve which may be utilized with an extraluminal balloon dissection apparatus in accordance with the invention.

DETAILED DESCRIPTION OF A PREFERRED EMBODIMENT

[0032] In the exemplary embodiment illustrated in FIG. 1, an extraluminal balloon dissection apparatus 11 includes a tunneling shaft assembly 30 substantially similar to the tunneling shaft assembly disclosed in application Ser. No. 07/893,988, an elongate balloon 32, a skin seal 21, and a removable balloon cover 51. The tunneling shaft assembly 30 has a piece handle 13. Alternatively, a hollow tube having either a one or two piece handle construction as disclosed in

Ser. No. 08/570,766 may be utilized with an elongate balloon according to the invention. The three-piece handle 13 includes a cannula 18, an obturator 15, and a tunneling shaft 16, each of which extend from a different section of the handle 13. The tunneling shaft 16 extends through a bore in the obturator 15, and the obturator 15 extends through the cannula 18. The tunneling shaft 16 may have an olive-shaped, or other blunt shaped obturator 17 mounted on its distal end to provide a blunt distal end for tunneling. A skin seal 21 substantially as described in Ser. No. 08/124,283 may be utilized if needed for the procedure to be performed, in which case, the skin seal 21 is slidably mounted and frictionally retained on the outer surface of the cannula 18. A moveable collar 26 on the skin seal 21 provides for adjustment on and to the outer surface of the cannula 18. The outer surface 22 of the skin seal 21 is progressively cylindrical and tapered and provided with helical threads 23 for engaging the skin of the patient to form a seal therewith.

[0033] As shown in FIGS. 1 and 2, an elongate balloon 32 is mounted on the tunneling shaft 16 which is part of the tunneling shaft assembly 30. The elongate balloon 32, which may be described as having a hot dog shape, is generally cylindrical and has a distal end 34 which extends substantially beyond the distal most point of the tunneling shaft 16 when fully inflated, as shown by the dashed extension lines in FIG. 1. The elongate balloon 32 is preferably formed from a nonelastic material so that its expansion envelope can be fairly well regulated as is known to those of skill in the art. The balloon cover 51, which may be formed integrally with the balloon 32 as disclosed in copending application Ser. No. 08/570,766, for example, or as a separable component as illustrated in FIG. 1, encloses a deflated balloon 32 and holds it against the tunneling shaft 16.

[0034] Prior to use, the distal portion 34 of the deflated balloon 32 is folded inwardly to shorten its length so that the distal portion 34 of the folded balloon 32 does not extend substantially beyond the distal extremity of the tunneling shaft 16. The distal portion 34 of the balloon 32 can be folded inwardly by inverting the distal portion 34 of the balloon 32 into the proximal portion 35 so that approximately one-half of the length of the balloon 32 is folded into the other half of the balloon 32. This reduces the overall length of the deflated balloon 32 to approximately one-half of its fully extended length. If a shorter folded balloon 32 is necessary for the particular procedure contemplated, it is possible to further shorten the balloon 32 by again folding the distal most portion of the balloon 32 inwardly so that the deflated balloon 32 is now only approximately one-fourth of its fully extended length.

[0035] In the embodiment shown in FIGS. 1 through 4, the balloon 32 is releasably secured to the tunneling shaft 16 by a sleeve 36, as best shown in FIG. 2. The sleeve 36 can be formed from the same material as the balloon 32 and may be formed as an integral part of the balloon 32 by bonding the balloon material together as shown at reference numeral 37 in FIG. 2. Alternatively, the sleeve 36 may be formed as a separate member of the balloon 32 and bonded to the balloon 32 by welding, heat sealing, or through the use of a suitable adhesive, for example. The sleeve 36 extends substantially along the entire length of the balloon 32 and circumscribes the tunneling shaft 16. The sleeve 36 is preferably provided with a weakened region 37 extending the length thereof which can be formed in a suitable manner,

such as by providing axial perforations extending along the length of the sleeve 36. The weakened region 37 permits the sleeve 36 to be separated from the tunneling shaft 16 when it is desired to separate the balloon 32 from the tunneling shaft 16, as will be described below.

[0036] In order to inflate the balloon 32, a flexible tubular member 41 may be utilized as an inflation lumen for the balloon 32. The distal extremity of the tubular member 41 is inserted into the balloon 32 so that the lumen in the tubular member 41 opens into the interior space of the balloon 32. A wye adaptor 42 is secured to the proximal extremity of the tubular member 41. A hand operated syringe 43 may be connected to the wye adaptor 42 as shown in FIG. 1 and utilized to inflate the balloon 32 with a suitable fluid, such as saline solution, for example. The wye adaptor 42 is also connected to another fitting 44 by tube 46 which has a pinch clamp 47 mounted thereon. A male evacuation fitting 44 terminates the tube 46 and may be connected to wall suction to evacuate the balloon 32 after the balloon 32 has been deployed to dissect as will be described below.

[0037] In FIGS. 1 through 4, a removable balloon cover 51 of the type described in copending application Ser. Nos. 07/893,988 or 08/124,283 may be utilized in connection with the extraluminal balloon dissection apparatus 11 disclosed herein. The removable balloon cover 51 serves to frictionally retain the collapsed balloon 32 relative to the tunneling shaft 16. The removable balloon cover 51 preferably has a weakened region 52 (see FIG. 2) extending along the length thereof to permit the balloon cover 51 to be separated from the balloon 32 and the tunneling shaft 16 when it is desired to inflate a balloon 32. An integral balloon cover of the type described in Ser. No. 08/267,488, for example, may be utilized with the balloon dissection apparatus 11 in lieu of the removable cover 51. Such an integral balloon cover may be provided with a weakened region extending along its length so that the balloon cover separates from the balloon 32 and tunneling shaft 16 as the balloon 32 is inflated. Alternatively, the balloon 32 can be packed into the balloon cover 51 without a guide shaft 16.

[0038] Turning now to FIGS. 3 and 4, operation and use of the extraluminal balloon dissection apparatus 11 will now be described in connection with an exemplary balloon dissection procedure. One example of a procedure where the present balloon dissection apparatus 11 may be used is saphenous vein bypass procedure where it is desired to improve the circulation of arterial blood in the leg 61 of a patient having a diseased artery in the leg 61. As shown in FIG. 3, to perform this procedure, an incision 63 is made through the skin 67 in the leg 61 immediately adjacent the saphenous vein 64 selected to serve as the bypass. The distal extremity defined by the olive-shaped tip 17 of the balloon dissection apparatus 11 is then introduced through the incision 63 and advanced along the saphenous vein 64 between the vein 64 and the skin 67 until the tunneling shaft 16 and folded balloon 32 are disposed within the leg 61 adjacent the saphenous vein 64. It should be appreciated that, if desired, dissection can be accomplished along the saphenous vein 64 on the side of the vein 64 away from the skin 67.

[0039] When the tunneling shaft 16 and folded balloon 32 are in the proper position adjacent the saphenous vein 64, the balloon cover 51 is removed, either by physically removing the balloon cover 51 (facilitated by finger ring 31) and

withdrawing the cover 51 from the incision or, alternatively, in the case where an integral balloon cover is utilized, by merely inflating the balloon 32 which causes the integral cover to separate. Once the balloon cover 51 has either been removed (or separated by inflation of the balloon in the case of an integral cover), the balloon 32 is progressively inflated by introducing a fluid, such as saline solution, for example, through the syringe 43 into the interior space of the balloon 32. As the balloon 32 begins to inflate, the distal portion 34 of the balloon 32 begins to unroll, everting outwardly and propagating in a distal direction downwardly in the leg 61 toward and beyond the knee 66 until the distal portion 34 of the balloon 31 is fully extended, as shown by the dashed line in FIG. 3. The saphenous vein 64 is dissected from adjacent tissue along its length as the balloon 32 progressively expands and forms a tunnel alongside the vein 64. Dissection follows a natural tissue plane immediately adjacent the vessel or elongate structure. The dissecting balloon 32 propagates along the vessel following a natural tissue separation plane between the vessel and surrounding tissue. Thus, dissection occurs as the balloon 32 progressively inflates and follows the desired natural separation plane alongside the vessel.

[0040] After the balloon 32 has been completely inflated and has extended alongside the vein 64 causing the vein 64 to be dissected from adjacent tissue, the balloon 32 is deflated by opening the clamp 47 and applying suction to fitting 44. After deflation, the balloon 32 may be withdrawn through the incision 63 by pulling on the tubular member 41 to cause the releasable balloon 32 to be separated from the tunneling shaft 16 along the weakened region 37 of the sleeve 36. The skin seal 21 is then optionally advanced and traded into the incision 63 to form a gas-tight seal with the skin 67 if it is desired to insufflate the dissected space alongside the saphenous vein 64. An insufflation gas may be introduced through the fitting 14 on the handle 13 into the dissected space between the saphenous vein 64 and the skin 67 to provide an atomic working space (68 in FIG. 4) extending lengthwise along the saphenous vein 64. The entire tunneling shaft assembly 30 can then be removed from the incision 63, leaving the skin seal 21 and cannula 18 in place to maintain a gas-tight seal with the leg 61. The cannula 18 may be provided with a duckbill or flapper valve (not shown) to prevent the insufflation gas from escaping through the cannula 18 after withdrawal of the tunneling shaft assembly 30.

[0041] The saphenous vein 64 has side branches 69 which are exposed within or adjacent to the insufflated anatomic space 68 extending along saphenous vein 64. Clips (not shown) can be applied to the side branches 69 in several ways. For example, an incision can be made at the distal extremity of the insufflated space 68 by the use of a trocar, for example, and a clip applicator can be introduced through the trocar and hemostats or clips can be applied to the side branches 69. In order to facilitate this aspect of the procedure, a laparoscope may be introduced through the skin seal 21 to permit the placement of the clips to be observed. In this manner, many of the side branches 69 can be clipped utilizing only one incision in the groin and another incision below the knee 66. Thus, the procedure of the present invention greatly reduces the number of incisions required to clip the side branches 69 of the saphenous vein 64 over traditional open bypass procedures.

[0042] Another method of clipping the side branches 69 involves the use of an operating endoscope which may be introduced through the skin seal 21. The operating endoscope has an instrument channel through which a clip applicator can be introduced into the dissected space adjacent the saphenous vein 68 to clip off the side branches 69 while the procedure is being viewed through the endoscope.

[0043] If it is desired to advance still further down the leg 68 than can be accomplished with the first balloon dissection apparatus 11, a second similar balloon dissection apparatus 11 can be introduced through a second incision lower down the leg and the same procedure utilized to dissect the saphenous vein 64 down to the ankle of the patient. The same as described above can be utilized to clip off the side branches 69 of that portion of the saphenous vein 64 that is dissected by use of the second apparatus 11. After clipping of the side branches 69 has been completed, valves within the saphenous vein 64 can be removed in a conventional manner if that is desired. To perform the arterial bypass procedure, the upper portion of the saphenous vein 64 can then be connected through the first incision to the artery it is desired to bypass and reconnected through the lower incision. The incisions may be closed in a conventional manner.

[0044] By utilizing a balloon dissection apparatus of the present invention, it is possible to provide working access to the saphenous vein 64 through only moderate sized incisions made at the top and bottom of the leg 61 and possibly one additional incision in the middle of the leg 61. Thus, use of an extraluminal balloon dissection apparatus eliminates many of the incisions in the leg 61 which have previously been required in order to clip off or occlude the side branches 69 of the saphenous vein 64. The reduced number and length of incisions greatly reduces the risk of infections from multiple and large surface area incisions. From a patient standpoint, the pain and recovery time in the hospital are greatly reduced over traditional procedures.

[0045] Balloon dissection apparatus as disclosed herein can also be used for harvesting the saphenous vein for use in a coronary bypass procedure, for example. In the past, it has been necessary to make a full length incision all the way down the leg 61 of the patient to remove the saphenous vein 64 for the bypass procedure. With a balloon dissection apparatus of the present invention, it is possible to make a single incision in the groin in the patient and then utilize the balloon dissection apparatus to create an anatomic working space adjacent the saphenous vein 64 in the leg 61 through balloon dissection. This can be accomplished by introducing an extraluminal balloon dissection 11 alongside the saphenous vein 64 and thereafter inflating the balloon 32 to cause it the evert outwardly and propagate down the leg, in the process dissecting tissue away from the saphenous vein 64 along substantially the entire length of the saphenous vein 64 to create an anatomic working space, as previously described. In this procedure the inflation pressures for the balloon 32 are generally below one atmosphere.

[0046] After dissection has occurred, the balloon 32 is removed, and the anatomic working space 68 created by balloon dissection is then insufflated and additional trocars, as needed, are inserted into the insufflated dissected space 68. Side branches 69 of the saphenous vein 64 may be exposed by additional manual dissection and are clipped and transected. The saphenous vein 64 is then dissected free

from its surrounding tissue bed and the proximal and distal ends of the vein 64 are clipped and transected to allow the saphenous vein 64 to be removed or harvested through the incision 63. This approach drastically reduces the length of the incision 63 which is normally required to harvest the saphenous vein 64. The saphenous vein 64 can be pulled out through the incision 63 and the side branches 69 can be closed on the operating table in a standard procedure. Similarly, as previously described, valves within the saphenous vein 64 can be removed or disabled in a conventional fashion if need be.

[0047] In connection with the present invention, it has been found preferable to utilize a nonelastomeric balloon 32 so that it is possible to control the shape of the dissected region. By way of example, for extraluminal procedures involving the saphenous vein, it is desirable to have a tunneling shaft 16 with a length of approximately 12 inches and a fully distended balloon 32 having a axial length of 20 to 30 inches and a maximum diameter when inflated of approximately 1 to 3 inches. It should be appreciated that different sizes of balloons can be provided in accordance with the present invention to provide inflated diameters as great as 3 to 4 inches where that may be necessary or desirable. Alternatively, the extraluminal dissection balloons can be of a relatively small diameter, such as 10 millimeters, for example, when it is desired to tunnel down along the natural plane of an artery for the purpose of inserting a synthetic graft, for example.

[0048] In place of a rigid tunneling shaft assembly 30, it should be appreciated that a semi-rigid tunneling assembly could be provided to give some flexibility, yet enough rigidity to make blunt dissection possible to facilitate the advancement of the balloon 32 to a desired location alongside the vessel of interest. It should also be appreciated that such a balloon dissection apparatus 11 could be utilized in conjunction with other vessels in the human body, as well as with other elongate structures such as the esophagus, carotid arteries, brain drain shunts, and nerves.

[0049] Another embodiment of an extraluminal balloon dissection apparatus 71, according to the invention, is shown in FIGS. 5 and 6. In this embodiment, the apparatus 71 include a conventional endoscope 72 which has a housing 73, a light inlet fitting 74 mounted on the housing 73, and an eye piece 76. The laparoscope 72 has a probe 77 extending from the housing 73. An objective lens (not shown) mounted in the distal extremity 78 of the probe 77 may provide a suitable viewing angle, such as a straight viewing angle parallel to the longitudinal axis of the probe 77 or an angle of 30 degrees with respect to the longitudinal axis, for example. As is well known to those of the skill in the art, the laparoscope 72 is provided with optics for receiving a light source at the fitting 74 and directing the light out the distal extremity 78 of the probe 77 so that light is supplied beyond the distal end 78 of the probe 77. This permits the surgeon to observe beyond the distal end 78 of the probe 77 the eyepiece 76 or on a video monitor, if the laparoscope utilized is capable of providing a video output.

[0050] The balloon dissection apparatus 71 may utilize, as a tunneling member, an elongate tubular member 81. The tubular member 81, in addition to serving as a scope cover for the laparoscope 72, also serves as a tunneling member to permit the apparatus 71 to be advanced bluntly alongside the

saphenous vein, following a natural dissection plane adjacent the vein. The tubular member **81** can be of the type described in copending application Ser. No. 08/267,488 and is preferably formed of a suitable transparent material, such as a clear polycarbonate. The tubular member **81** has a bore extending therethrough which is sized so that it can readily accommodate the probe **77** of the laparoscope **72**. The tubular member **81** may have sufficient length to accept the entire length of the probe **77**. The tubular member **81** has a rounded, substantially hemispherical tip **84** at its distal extremity which can be formed integrally therewith as shown, or alternatively, as a separate piece and bonded to the tubular member **81** by the use of a suitable adhesive, for example. The tubular member **81** may also have an open, yet blunt, distal extremity as disclosed in copending application Ser. No. 08/570,766, to permit observation through the laparoscope **72** through the open distal end. When a closed, rounded tip **84** is utilized as shown in **FIG. 5**, the tip **84** is preferably formed from a transparent material, such as a clear polycarbonate, to facilitate observation through the distal end **84**.

[0051] To further facilitate observation through a closed distal end, a baffle **86** may be mounted in the bore of the tubular member **81** and extends laterally and axially thereof. The baffle **86** can be formed integrally with the distal end **84** or, alternatively, can be formed of a separate material which is then bonded to the distal end **84** by a suitable adhesive. Assuming that the laparoscope **72** is of a type in which the light transmitting capabilities are provided through the other semi-circular region of the probe **77**, and viewing capabilities are provided through the other semi-circular region, the baffle **86** is positioned in such a manner so that it will inhibit, if not prevent, light emitted from the distal extremity **78** of the probe from bouncing off the inner surface of the distal end **84** and creating a glare which may obscure vision through the eye piece **76**. In order to prevent such a glare, the baffle **86** is preferably formed of an opaque material, such as a black opaque material, for example. Alternatively, the baffle **86** may be provided with one surface which is opaque so that light cannot be transmitted through the baffle **86** to the lower half of the probe **77** making a clear field of vision possible the tubular member **81**.

[0052] An elongate balloon **92** similar to the balloon **32** in the previous embodiment may be utilized with the apparatus **71**. The balloon **93** has proximal and distal extremities **93** and **94**, respectively. (See **FIG. 6**). As the previous embodiment, the distal extremity **94** may be folded inwardly into the interior of the balloon **92** to reduce the overall balloon length by approximately one-half. As previously described, the balloon **92** may have its overall length reduced even further by additional inward folding. As shown in **FIG. 6**, the balloon **92** has a sleeve **96** extending axially thereof for at least a portion of its length. The sleeve **96** surrounds the tubular member **81** and secures the balloon **92** to the tubular member **81**. The sleeve **96** is provided with a weakened region **97** extending the length thereof to permit the balloon **92** to be removed from the tubular member **81**. A tubular member **98** of the type previously described extends into the interior space of the balloon **92** and maybe connected to a suitable inflation source, such as a syringe, for example, to communicate fluid through its internal lumen into the balloon **92**.

[0053] As in the previous embodiment, a removable balloon cover **101** may be utilized in connection with the apparatus **71**. Alternatively, an integral balloon cover, as previously described, may also be used. The balloon cover **101** surrounds the folded balloon **92** and retains the balloon **92** in close proximity to the tubular member **81** prior to removal of the cover **101** and deployment of the balloon **92**. The balloon cover **101** has a weakened region **102** (see **FIG. 6**) extending the length thereof and may be provided with a finger ring **103** to facilitate removal of the cover **101**, as previously described.

[0054] A skin seal **106** of the type previously described may also be utilized in connection with the apparatus **71**. The skin seal has a conical surface which is provided with a continuous helical thread **111**. An axially movable collar **112** is mounted on the skin seal **106** and is moveable to releasably clamp the skin seal to the scope cover **81**.

[0055] Operation and use of the extraluminal balloon dissection apparatus **71** is very similar to that of the balloon dissection apparatus **11** previously described. The principal difference in the this embodiment is that a laparoscope **72** is continuously available during the introduction of the apparatus **71** into an incision and during advancement of the apparatus **71** alongside the elongate structure or vessel to be dissected free of adjacent tissue. As before, the apparatus **71** can be tunneled alongside the saphenous vein, either on the side of the saphenous vein adjacent the skin, or on the side away from the skin. The balloon **92** is then inflated to dissect the vein away from adjacent tissue beyond the distal end **84** of the tubular member **81**. It has been found preferable to dissect alongside the saphenous vein on the side of the leg away from the skin. By utilizing this approach, the light from the laparoscope **72** makes it possible to visually identify the saphenous vein location and side branches by forming a silhouette on the skin. This makes it possible to locate further necessary incisions and minimize their size.

[0056] After the balloon **92** has been disposed adjacent the saphenous vein or other elongate structure, the cover **101** is moved from the folded balloon **92** and tube member **81**, by separation along its weakened region **102**. Removal of the cover **101** is facilitated by finger ring **103**. The balloon **92** is then inflated and the balloon **92** unrolls said everts in a distal direction to dissect the saphenous vein from adjacent tissue beyond the distal end **84** of the tubular member **81**. (If an integral cover is utilize in lieu of the hard cover **101**, the integral cover ruptures along its weakened region during inflation thereby releasing the balloon **92**). The balloon **92** can be viewed through the laparoscope **72** as it unrolls through the laparoscope **72**. After the balloon **92** is completely distended and inflated, it can be deflated as previously described and stripped off the tubular member **81** along the weakened region **97**, and withdrawn through the incision. Thereafter, the in seal **106** may be threaded into the incision to provide a substantially gas-tight seal therewith if a gas-tight operating space is desired. The laparoscope **72** and tubular member **81** can then be removed from the skin seal **106** and a cannula having an insufflation capability can be introduced through the seal **106** to insufflate the dissected anatomic working space adjacent the vessel. Alternatively, another incision can be made and the desired surgical procedure can be performed through the other incision while viewing through the laparoscope **72** already inserted in the first incision. Thus, the balloon dissection apparatus **71** offers

the advantages obtained with the balloon dissection apparatus **11** previously described, while at the same time making it possible to view blunt dissection as it occurs adjacent the saphenous vein or other elongate structure.

[0057] Referring now to **FIGS. 7 through 9**, another embodiment of a balloon dissection apparatus **121** according to the present invention is illustrated. The apparatus **121** is substantially similar to the apparatus **71** of the previous embodiment, the difference being that the tubular member **81** is inserted into (rather than being disposed alongside) the elongate balloon **136**. As in the previous embodiment, the tubular member **81** receives a conventional laparoscope **72** and serves the dual function of a scope cover and blunt tunneling member.

[0058] As shown in **FIG. 7**, the tubular member **81** is inserted inside the inverted and folded elongate balloon **136** between one of the inwardly folded layers of the balloon **136** and an outer, proximal balloon layer. The elongate balloon **136** may have its proximal end **137** secured to the tubular member **81** in a fluid-tight manner, such as by gluing or other bonding techniques. Alternatively, the elongate balloon **136** may be completely sealed, and the tubular member **81** inserted into the proximal end of the elongate balloon **136**, inverting the sealed balloon **136** inwardly as the tubular member **81** is advanced toward the distal most portion of the balloon **136**, as disclosed in application Ser. No. 08/570,766.

[0059] In the exemplary embodiment of **FIG. 7**, the distal portion **139** of the balloon **136** is inverted and folded into the proximal portion **137** of the balloon **136** such that the distal half of the balloon **136** resides within the proximal half, as previously described. The tubular member **81** is inserted through the open proximal end of the balloon **136** and advanced between the balloon layers defining the proximal and distal halves of the balloon **136** until its distal extremity is adjacent the approximate midpoint, now distal, fold in the balloon **136**. Because the tubular member **81** and hence, the laparoscope **72**, are within space of the balloon **136**, the balloon **136** is preferably formed from a substantially transparent material so that laparoscopic observation is still possible. In this case, observation occurs through the distal extremity of the tubular member **81** and the folded balloon **136**. An open baffle **86**, as previously described, may be utilized to minimize unwanted reflections of light into the laparoscope **72**. Alternatively, a tubular member **81** having an open distal end substantially as described in copending application Ser. No. 08/570,766 may be utilized so that laparoscopic observation is through the open distal end of the tubular member **81**.

[0060] A balloon cover **146**, having a longitudinally extending and weakened region **147**, may also be utilized in this embodiment. The balloon cover **146** serves to compress the folded collapsed balloon **136** into a more compact state and to frictionally retain the balloon **136** on the tubular member **81** during tunneling advancement of the apparatus **121**. It is to be noted that an integral cover, as previously described, could be utilized in lieu of the removable balloon cover **146** in this embodiment as well.

[0061] Operation and use of the balloon dissection apparatus **121** is substantially similar to that of the previous embodiments. Because the balloon **136** and the distal extremity of the scope cover **81** are substantially transparent, observation through the laparoscope is possible during blunt

tunneling and subsequent balloon dissection. After the apparatus **121** has been inserted through an incision adjacent the elongate to be dissected and advanced bluntly under laparoscopic observation, if desired, to the location where dissection is to be performed, the balloon cover **146** is removed and the balloon **136** is inflated through the tubular member **98**. The balloon cover **146** is removed by pulling the finger ring **103** proximally to cause the balloon cover **146** to separate from the tubular member **81** and balloon **136** along its weakened region **147**.

[0062] As the balloon **136** is inflated, it everts and propagates distally following a natural separation plane alongside the elongate structure in a manner similar to the balloons previously described. The balloon **136** inflates around the tubular member **81** providing an anatomic working space adjacent the elongate structure, as shown in cross-section in **FIG. 9**. After the elongate structure has been dissected from adjacent tissue by the balloon **136**, the balloon **136** is deflated and the apparatus **121** and laparoscope **72** are withdrawn through the incision, either serially or together. The remainder of the surgical procedure is then completed and the incision (or incisions) closed.

[0063] Another embodiment of a balloon dissection apparatus **200** according to the invention is shown in **FIGS. 10 and 11**. The apparatus **200** is provided with a laterally extending thumb-shaped reservoir **201** which is itself part of the elongate balloon **203**. A housing **202** having a tubular balloon sleeve **206** extending therefrom terminates the balloon **203** and may receive a laparoscope (not shown) if visualization is required or desirable for the procedure contemplated. An instrument seal **204**, which may be of the type described in copending application Ser. No. 08/570,766, is mounted in the housing **202** to provide a fluid-tight seal between the interior of the handle **202**, which is in fluid communication with the interior of the balloon **202**, and a laparoscope. The balloon sleeve **206** is similar to the balloon sleeve described in copending application Ser. No. 08/403,012, and may be formed integrally with the housing **202** or as a separate member.

[0064] The elongate balloon **203** is substantially similar to the balloons utilized in connection with the previous embodiments and may be folded inwardly to reduce its predeployment length in similar fashion. The proximal end of the balloon **203** is open and may be terminated in a fluid-tight manner in the housing **202**, as shown, or on an outer surface of the balloon sleeve **206**. The open proximal end of the balloon **203** may be secured between the interior of the housing **202** and the balloon sleeve **206** as described in application Ser. No. 08/403,012. The balloon **203** is preferably formed from a substantially transparent material to facilitate laparoscopic observation through the balloon **203** as described below.

[0065] Prior to use, the distal portion **205** of the deflated balloon **203** is inverted and folded inwardly to shorten the overall length of the balloon **203**. The distal portion **205** of the inverted, folded balloon **203** is pushed into the reservoir **201**, as shown in **FIG. 10**. Additional folds may be provided, as necessary, to further shorten the deflated balloon **203** and to make it possible to store the majority of the balloon **203** in the reservoir **201**.

[0066] The reservoir **201** provides several advantages over the previous embodiments. First, the reservoir **201** allows a

more compact design in that a long balloon may be folded and stored in the reservoir **201** outside the body with only a relatively short portion of the balloon **203** extending into the incision. This feature is advantageous because it allows the use of a relatively short insertion device (i.e., the balloon sleeve **206** or the distal tip of the laparoscope when the balloon sleeve **206** is not provided, as shown in later embodiments of the invention, or a finger of hand) instead of the relatively long tunneling members contemplated in the previous embodiments. In this regard, it has been found desirable to utilize the balloon **203**, which follows a natural dissection plane, rather a blunt tunneling member, which may not follow the natural plane to perform as much of the dissection as possible. Second, because the majority of the balloon **203** is disposed outside the body, the axial length of the balloon **203** is not as constrained to the length of the tunneling member as in previous embodiments.

[0067] An inflation harness **214**, also of the type previously described in Ser. No. 08/570,766, may be utilized to communicate a suitable inflation medium, such as saline solution, for example, to the interior of the balloon **203** to inflate the balloon **203**. An inflation lumen **207** extends from the balloon **203** and is connected to a tubular member **208**, which in turn is connected to a wye fitting **209**. Wye fitting **209** may have one port connected to a luer-type fitting **213** and another port connected to another tubular member **211**. A pinch clamp **210** is mounted on the tubular member **211** and is clamped off during balloon inflation and opened during deflation. A male fitting **212** terminates the tubular member **211** and is suitable for connecting to a hospital evacuation source when it is desired to deflate the balloon **203**.

[0068] In a preferred method of use, a laparoscope is inserted through the instrument seal **204** and advanced through the balloon sleeve **206** until its distal end reaches the distal end of the balloon sleeve **206** and the folded balloon **203** which covers the distal end of the balloon sleeve **206**. The apparatus **200** may then be inserted into the body of a patient through an incision adjacent the elongate structure to be dissected. Alternatively, the apparatus **200** may be introduced through the incision in to the body without the aid of the laparoscope if observation is not required or deemed necessary. Although a laparoscope is preferably utilized with the apparatus **220**, its use is optional in the balloon sleeve **206** functions as a separate tunneling member to facilitate advancement of the apparatus **200** to the desired point adjacent the elongate structure.

[0069] When a laparoscope is utilized, the apparatus **200** is advanced alongside the elongate structure using the laparoscope and/or balloon sleeve **206** a tunneling members until a desired location for balloon dissection is reached. It is to be noted that the reservoir **201** does not generally enter the incision and remains outside the body. When the desired location is reached, the balloon **203** is inflated by connecting a suitable inflation source, such as a syringe, for example, to the luer fitting **213** and introducing the inflation medium into the interior of the balloon **203**. As the inflation medium is progressively used, the balloon **203** everts outwardly propagating alongside the elongate structure to dissect adjacent tissue away from the structure, as previously described. As the balloon **203** is inflated, the distal portion **205** of the balloon **203** stored in the reservoir **201** is gradually withdrawn from the reservoir by the distal propagation of the

balloon **203**. Inflation continues until the distal portion **205** of the balloon **203** is completely withdrawn from the reservoir **201** and the balloon **203** is fully distended alongside the structure. (See **FIG. 11**) The surgeon can observe the progress of the dissection procedure through the laparoscope from inside the balloon **203** as the balloon **203** unrolls and propagates alongside the structure.

[0070] After an operating space adjacent the vessel or structure has been created by dissection, the elongate balloon **203** is deflated by opening the pinch clamp **210** and withdrawing the fluid from the balloon **203** through the male fitting **212**. The laparoscope and apparatus **200** may then be withdrawn from the incision and additional cannulas or other laparoscopic instruments, as contemplated by the particular procedure being performed, may be inserted through the incision into the dissected operating space and the procedure completed.

[0071] Turning now to **FIGS. 12 and 13**, another embodiment of an extraluminal balloon dissection apparatus **225** according to the invention is disclosed. **FIG. 12** illustrates the apparatus **225** as it would appear prior to use with the elongate balloon **203** inverted, folded and stored within balloon reservoir **201**. **FIG. 13** illustrates the apparatus **225** after the balloon **203** has been inflated and fully distended. The apparatus **225** is identical to the previous apparatus **200** except that the balloon sleeve **206** has been omitted and the inflation **214** has been relocated from the side of the balloon **203** to the reservoir **201**. In this regard, it should be noted that the inflation harness **214** in the embodiment of **FIGS. 10 and 11** could also extend from the reservoir **201**.

[0072] Use of the apparatus **225** is likewise identical to use of the apparatus **200**, with the exception that a laparoscope (not shown) is preferably utilized to guide the apparatus **225** into the incision and to advance the apparatus **225** to a point adjacent the elongate structure to be dissected. The surgeon may manually insert the apparatus **225** into the incision adjacent the elongate structure without the aid of a laparoscope.

[0073] If observation is desired, the laparoscope is inserted through the seal **204** in the housing **202** and may be advanced distally into the reservoir **201** following the withdrawal of the folded balloon **203** from the reservoir **201**. As continued inflation causes the folded balloon **203** to propagate distally, the portion of the balloon **203** stored in the reservoir **201** is withdrawn and the laparoscope may be further advanced inside the interior space of the distended balloon **203** as desired. The flexible apparatus **225** allows the insertion angle of the laparoscope to be easily adjusted to parallel the structure being dissected.

[0074] In **FIG. 14**, an extraluminal balloon apparatus **230** has bulb-shaped balloon **222** with an elongate neck which may be utilized in place of the elongate hot dog shaped balloon **203** of the apparatus illustrated in **FIGS. 10 and 11**. Similarly, **FIG. 15** illustrates an apparatus **235** having a bulb-shaped balloon **222** with an elongate neck **221** in place of the elongate balloon **203** in the apparatus of **FIGS. 12 and 13**. Other than the shape of the balloon **222**, the embodiments of the invention illustrated in **FIGS. 14 and 15** are identical to their counterpart elongate balloon **203** embodiments illustrated in **FIGS. 10 and 11** and **FIGS. 12 and 13**, respectively.

[0075] The balloon **222** utilized in the **FIGS. 14 and 15** embodiments has a wide surface area distal portion which

may be shaped as illustrated, or in any one of the shapes illustrated in application Ser. No. 08/570,766, for example. An elongate neck 221 extends from the distal portion of the balloon 222 and may be terminated within the housing 202 or on the balloon sleeve 206 (if utilized) as previously described. The deflated balloon 222 may be inverted inwardly, and the outer margins of the distal portion of the balloon 222 wrapped or folded together to compact and shorten the balloon 222. The inwardly folded and wrapped balloon 222 may then be pushed inside the balloon reservoir 201, as in previous embodiments.

[0076] When the balloon 222 is inflated, it will evert and propagate distally in a similar manner to that of the elongate balloon 203 of the previous embodiments. When the balloon 222 is essentially fully everted, the side margins of the distal portion of the balloon 222 will unroll, and the distal portion of the balloon 222 will fully expand. The balloon 222 may be used either as a dissector or as a retractor, depending on the application. One application where the balloon 222 has been found to have particular utility is in connection with an aortic bifemoral bypass procedure, where either apparatus 230 or 235 may be inverted into the femoral canal of the patient and then inflated to cause the balloon 222 to dissect and retract the peritoneum from the pelvic floor.

[0077] FIGS. 16 and 17 illustrate a bi-directional dissection apparatus 240 which is provided with two integrally formed balloon reservoirs 201, each of which function to store approximately one half of the bi-directionally expanding elongate balloon 242. The balloon 242 has a left portion 243 and a right portion 244, as shown packed in the reservoir 201 in the deflated predeployment state in FIG. 16 and in the fully expanded distended state in FIG. 17. The respective right 244 and left 243 halves of the elongate balloon 242 may be inverted inwardly and folded in the manner previously described. Each respective half of the folded elongate balloon 242 is then pushed into the opposite reservoir 201. A balloon inflation harness 214 of the type utilized in the previous embodiments may be utilized to inflate the balloon 242 and may be located on either one of the balloon reservoirs 201 or at some other point on the balloon 242.

[0078] The method of using the apparatus 240 is substantially similar to the methods of use previously described with regard to the prior embodiments. The apparatus 240 is inserted through an incision adjacent an elongate structure, and the balloon 242 is inflated. The right 244 and left 243 halves of the balloon 242 may be deployed simultaneously or sequentially, as desired. In practice, the right 244 and left 243 halves of the balloon 242 can be made to deploy sequentially by manually or otherwise impeding from unfolding one of balloon halves while the other half is permitted to unfold. After the first half has unfolded and fully distended, the manual restraint may be released to deploy the other half. Each half of the balloon 242 everts and propagates distally with the folded balloon halves withdrawing from the reservoir 201 as the balloon halves propagate in the manner previously described.

[0079] A practical use of the apparatus 240 illustrated in FIGS. 16 and 17 is where it is desirable to avoid an anatomical structure that lies in the desired dissection path if a single entry point were utilized, or a structure which might impede dissection. Alternatively, the apparatus 240 may be utilized where it is desired to make an incision

approximately at the midpoint of the portion of the elongate structure to be dissected and then to dissect the structure away from adjacent tissue in both axial directions. One example of a location where it may be desirable to utilize the bi-directional balloon 242 is the knee, when anatomical structures within the knee may preclude, or make difficult, use of an apparatus in which the dissecting balloon only expands in one direction. The balloon 242 can be inserted through an incision adjacent a blocking anatomic structure, and inflated to cause the balloon halves to propagate in opposite axial directions alongside an elongate structure, thereby avoiding the blocking structure.

[0080] FIGS. 18 and 19 illustrate a variation on the apparatus 240 illustrated in FIGS. 16 and 17. The extraluminal balloon dissection apparatus of FIGS. 18 and 19 differs from the apparatus 240, only in that housings 202 having instrument seals 204 are provided to receive a laparoscope. The housings 202 and seals 204 are as previously described and are mounted on the balloon reservoirs 201 which are open-ended in this embodiment. The open-ended balloon reservoirs 201 may be secured within the housing 202 in a fluid-tight arrangement, as previously described. The addition of housings 202 to the apparatus 245 permits a laparoscope (not shown) to be inserted through the instrument seal 204 and the housing 202 into the interior space of the balloon 242. After the device 245 has been inserted through a incision in the body adjacent the elongate structure by use of a finger or other aid, the elongate bi-directional balloon 242 is inflated to dissect tissue adjacent the elongate structure, starting from the middle of the structure and thereafter propagating axially into two different directions. (See FIG. 19) As the balloon 242 is inflated, a laparoscope may be inserted through the housing 202 having the instrument seal 204 and advanced following the balloon 242 alongside the structure being dissected. In order to advance the laparoscope into the balloon 242, it may be necessary to bend the housing 202 and reservoir 201 slightly to align the laparoscope with the axis of the everting balloon 242 as it dissects alongside the structure.

[0081] FIG. 20 illustrates the use of a reinforcing glove or sheath 250 which may be utilized to reinforce the region of the balloon 203 around the balloon reservoir 201. The reinforcing sleeve 250 may also extend distally of the reservoir 201, as shown in FIG. 20. Although the use of a reinforcing sleeve 250 is illustrated in FIG. 20 in connection with the extraluminal balloon dissection apparatus 200 previously described with reference to FIGS. 10 and 11, it should be appreciated that the reinforcing sleeve 250 could be utilized in connection with any of the embodiments having a balloon reservoir, or otherwise where it is desired to reinforce a portion of a balloon. The reinforcing sleeve 250 may be formed of the same material as the elongate balloon 203 and mounted such that it surrounds the reservoir 201 and the portion of the elongate balloon 203 into which the balloon sleeve 206 extends. The reinforcing glove 250 may be formed from a flat or sheets of material and may optionally be bonded to the reservoir 201. Alternatively, a reinforced monolithic structure may be used. The function of reinforcing sleeve 250 is to reinforce any weak spots on a balloon that may occur, on the reservoir 201 for example, or alternatively, to reinforce a weak spot on balloon that may occur within the body. Such weak spots may be caused by manufacturing variations in the balloon or by tissue differ-

ences with in the body and, without reinforcement, may be manifested in balloon aneurism behavior.

[0082] From the foregoing, it can be seen that the balloon dissection apparatus and methods disclosed herein are particularly suitable for the treatment of elongate structures, such as vessels, using extraluminal procedures. Extraluminal balloon dissection as disclosed herein has a wide variety of applications where it is desired to dissect alongside an elongate structure to create an anatomic working space exposing the structure. The procedures contemplated herein are minimally invasive in that small incisions utilized and body tissue is minimally disrupted. Because dissection is along a naturally occurring tissue plane adjacent the elongate structure, bleeding is minimized and the time required for healing is reduced. Other patient advantages offered by extraluminal balloon dissection include marked reductions in recovery time and post-surgery pain over traditional open procedures.

[0083] Having thus described an embodiment of the invention, it will now be appreciated that the objects of the invention have been fully achieved, and it will be understood by one skilled in the art that many changes in construction and widely differing embodiments and applications of the invention will suggest themselves without departing from the spirit and scope of the invention. Accordingly, the written description provided herein is purely demonstrative and is not intended to be in any sense limiting.

1-17. (canceled)

18: An apparatus for penetrating tissue comprising:

a laparoscope having a housing and a probe extending distally from the housing;

a tunneling shaft including an elongate tubular member formed of a transparent material and defining a bore

therein sized to accommodate the probe of the laparoscope, the tubular member having a tapered tip at a distal end of the tubular member and formed integrally therewith, the tip being shaped so as to permit the apparatus to be advanced bluntly through tissue; and

a balloon circumferentially disposed about the tunneling shaft.

19: The apparatus of claim 18, wherein the tunneling shaft comprises a transparent polycarbonate material.

20: The apparatus of claim 18, further comprising:

an inflation harness for introducing an inflation medium into said balloon, wherein a proximal end of the balloon is sealingly secured to the tubular member.

21: The apparatus of claim 18, further comprising a removable balloon cover that encloses the balloon and the tunneling shaft.

22: The apparatus of claim 18, further comprising a skin seal.

23: The apparatus of claim 20, wherein the balloon is folded inwardly to reduce its length.

24: The apparatus of claim 20, wherein a fully inflated length of the balloon is greater than a length of the tubular member.

25: The apparatus of claim 18, wherein the tapered tip includes a baffle that inhibits light emitted from the laparoscope from reflecting off interior surfaces of the tapered tip.

26: The apparatus of claim 25, wherein at least one surface of the baffle inhibits transmission of light there-through.

27: The apparatus of claim 23, wherein the balloon rolls outward and everts in a distal direction when an inflation medium is supplied to the balloon.

* * * * *

专利名称(译)	腔外球囊解剖		
公开(公告)号	US20060106414A1	公开(公告)日	2006-05-18
申请号	US11/273508	申请日	2005-11-14
[标]申请(专利权)人(译)	GEN手术INNOVATIONS		
申请(专利权)人(译)	普外科创新股份有限公司.		
当前申请(专利权)人(译)	普外科创新股份有限公司.		
[标]发明人	FOGARTY THOMAS J HERMANN GEORGE D ECHEVERRY JAN M MOLLENAUER KENNETH H		
发明人	FOGARTY, THOMAS J. HERMANN, GEORGE D. ECHEVERRY, JAN M. MOLLENAUER, KENNETH H.		
IPC分类号	A61M29/00 A61M25/00 A61B17/32 A61B17/00 A61B17/22 A61B17/32 A61B17/34 A61B19/00 A61F2/82 A61F2/84 A61M25/01 A61M25/10 A61M29/02		
CPC分类号	A61B17/00008 A61B17/0218 A61B17/3431 A61B19/5212 A61B2017/00557 A61B2017/22061 A61B2017/22062 A61B2017/320044 A61B2017/320048 A61M25/0194 A61M25/10 A61M25/1002 A61M29/02 A61M2025/1081 A61B90/361		
其他公开文献	US7314475		
外部链接	Espacenet USPTO		

摘要(译)

本发明提供了一种球囊解剖装置和使用方法，其中利用细长球囊沿着沿着血管或结构的自然存在的路径的区域进行解剖，所述血管或结构例如入口，静脉，淋巴管，所述，食道，甚至是神经束。

