



US008317809B2

(12) **United States Patent**
Nolan et al.

(10) **Patent No.:** **US 8,317,809 B2**
(45) **Date of Patent:** **Nov. 27, 2012**

(54) **APPARATUS AND METHOD FOR PERFORMING A BYPASS PROCEDURE IN A DIGESTIVE SYSTEM**

(75) Inventors: **Tim Nolan**, South Salem, NY (US); **Ernie Aranyi**, Easton, CT (US); **John Klinger**, Newtown, CT (US); **Keith Ratcliff**, Newtown, CT (US); **John Charles Robertson**, Cheshire, CT (US)

(73) Assignee: **Covidien LP**, Mansfield, MA (US)

(*) Notice: Subject to any disclaimer, the term of this patent is extended or adjusted under 35 U.S.C. 154(b) by 0 days.

(21) Appl. No.: **13/023,604**

(22) Filed: **Feb. 9, 2011**

(65) **Prior Publication Data**

US 2011/0137325 A1 Jun. 9, 2011

Related U.S. Application Data

(60) Continuation of application No. 11/640,080, filed on Dec. 15, 2006, now Pat. No. 7,901,416, which is a division of application No. 10/234,086, filed on Aug. 30, 2002, now Pat. No. 7,179,267, which is a continuation of application No. PCT/US01/07105, filed on Mar. 5, 2001.

(60) Provisional application No. 60/187,121, filed on Mar. 6, 2000.

(51) **Int. Cl.**

A61B 17/08 (2006.01)

A61B 17/04 (2006.01)

(52) **U.S. Cl.** **606/153; 227/175.1**

(58) **Field of Classification Search** **606/153; 227/175.1, 179.1, 181.1**

See application file for complete search history.

(56) **References Cited**

U.S. PATENT DOCUMENTS

4,157,709 A 6/1979 Schuster et al.
4,207,898 A 6/1980 Becht
4,304,236 A 12/1981 Conta et al.
4,328,805 A 5/1982 Akopov et al.
4,458,681 A 7/1984 Hopkins
4,473,077 A 9/1984 Noiles et al.

(Continued)

FOREIGN PATENT DOCUMENTS

DE 1 057 729 3/1955

(Continued)

OTHER PUBLICATIONS

US 5,826,777, 10/1998, Green et al. (withdrawn)

Primary Examiner — Julian Woo

(57) **ABSTRACT**

Surgical instrumentation and methods for performing a bypass procedure in a digestive system incorporate laparoscopic techniques to minimize surgical trauma to the patient. The instrumentation includes an outer guide member dimensioned for insertion and passage through an esophagus of a patient and defining an opening therein extending at least along a portion of the length of the outer guide member, an elongate anvil delivery member at least partially disposed within the opening of the outer guide member and being adapted for longitudinal movement within the outer guide member between an initial position and an actuated position and an anvil operatively engageable with the delivery member. The anvil includes an anvil rod defining a longitudinal axis and an anvil head connected to the anvil rod. The anvil head is at least partially disposed within the opening of the outer guide member when in the initial position of the delivery member and is fully exposed from the distal end of the outer guide member upon movement of the delivery member to the actuated position.

15 Claims, 39 Drawing Sheets

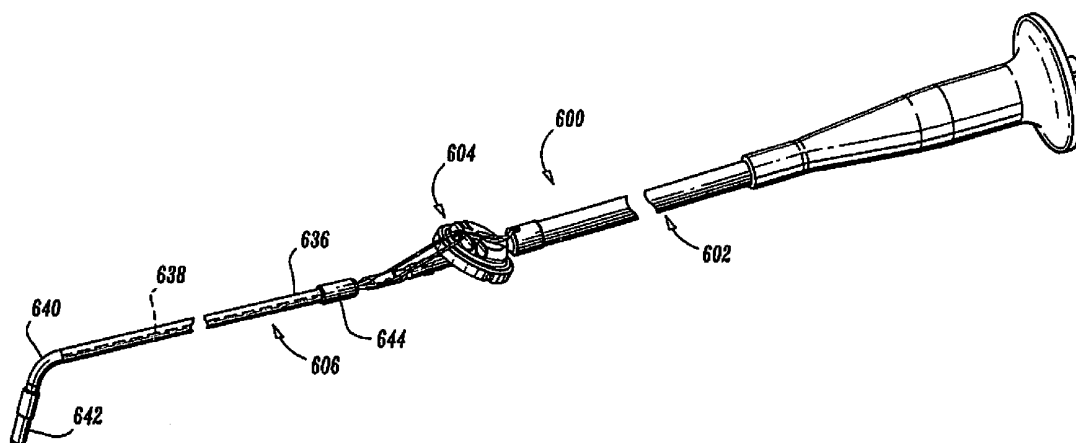

U.S. PATENT DOCUMENTS

4,576,164 A 3/1986 Richeson
 4,592,339 A 6/1986 Kuzmak et al.
 4,601,710 A 7/1986 Moll
 4,605,001 A 8/1986 Rothfuss et al.
 4,646,745 A 3/1987 Noiles
 4,667,673 A 5/1987 Li
 4,696,288 A 9/1987 Kuzmak et al.
 4,723,545 A 2/1988 Nixon et al.
 4,760,837 A 8/1988 Petit
 4,803,985 A 2/1989 Hill
 4,817,847 A 4/1989 Redtenbacher et al.
 4,848,367 A 7/1989 Avant et al.
 4,873,977 A 10/1989 Avant et al.
 4,964,863 A 10/1990 Kanshin et al.
 5,033,481 A 7/1991 Heyler, III
 5,065,772 A 11/1991 Cox, Jr.
 5,074,868 A 12/1991 Kuzmak
 5,083,576 A 1/1992 Ruiz-Razura et al.
 5,104,025 A 4/1992 Main et al.
 5,119,983 A 6/1992 Green et al.
 5,122,156 A 6/1992 Granger et al.
 D331,971 S 12/1992 Main
 5,197,648 A * 3/1993 Gingold 227/179.1
 5,205,459 A 4/1993 Brinkerhoff et al.
 5,226,429 A 7/1993 Kuzmak
 5,261,920 A 11/1993 Main et al.
 5,297,536 A 3/1994 Wilk
 5,314,435 A 5/1994 Green et al.
 5,314,436 A 5/1994 Wilk
 5,327,914 A 7/1994 Shlain
 5,330,486 A 7/1994 Wilk
 5,344,059 A 9/1994 Green et al.
 5,345,949 A 9/1994 Shlain
 5,350,104 A 9/1994 Main et al.
 5,355,897 A 10/1994 Pietrafitta et al.
 5,360,154 A 11/1994 Green
 5,376,376 A 12/1994 Li
 5,382,231 A 1/1995 Shlain
 5,395,030 A 3/1995 Kuramoto et al.
 5,401,241 A 3/1995 Delany
 5,445,644 A 8/1995 Pietrafitta et al.
 5,449,368 A 9/1995 Kuzmak
 5,454,824 A 10/1995 Fontayne et al.
 5,458,131 A 10/1995 Wilk
 5,549,621 A 8/1996 Bessler et al.
 5,588,579 A 12/1996 Schnut et al.
 5,601,604 A 2/1997 Vincent
 5,603,698 A 2/1997 Roberts et al.
 5,626,591 A 5/1997 Köckerling et al.
 5,639,008 A 6/1997 Gallagher et al.
 5,658,298 A 8/1997 Vincent et al.
 5,665,093 A 9/1997 Atkins et al.
 5,718,360 A 2/1998 Green et al.
 5,718,666 A 2/1998 Alarcon

5,741,268 A 4/1998 Schütz
 5,766,187 A 6/1998 Sugarbaker
 5,771,903 A 6/1998 Jakobsson
 5,860,581 A * 1/1999 Robertson et al. 227/179.1
 RE36,176 E 3/1999 Kuzmak
 5,902,247 A 5/1999 Coe et al.
 5,902,333 A 5/1999 Roberts et al.
 5,919,136 A 7/1999 Rao et al.
 5,938,669 A 8/1999 Klaiiber et al.
 5,976,078 A 11/1999 Bridges
 5,984,964 A 11/1999 Roberts et al.
 6,063,025 A 5/2000 Bridges et al.
 6,067,990 A 5/2000 Kieturakis
 6,117,148 A 9/2000 Ravo et al.
 6,149,660 A 11/2000 Laufer et al.
 6,193,129 B1 2/2001 Bittner et al.
 6,258,107 B1 7/2001 Balazs et al.
 6,338,737 B1 1/2002 Toledano
 6,648,900 B2 11/2003 Fleischman et al.
 6,648,901 B2 11/2003 Fleischman et al.
 6,673,084 B1 1/2004 Peterson et al.
 6,702,828 B2 3/2004 Whayne
 6,939,328 B2 9/2005 Raulerson
 7,090,686 B2 8/2006 Nobles et al.
 7,128,748 B2 10/2006 Mooradian et al.
 7,402,172 B2 7/2008 Chin et al.
 7,494,038 B2 2/2009 Milliman
 7,942,302 B2 5/2011 Roby et al.
 2002/0173809 A1 11/2002 Fleischman et al.
 2003/0028178 A1 2/2003 Chin
 2003/0144686 A1 7/2003 Martinez et al.
 2004/0068278 A1 4/2004 Fleischman et al.
 2005/0059996 A1 3/2005 Bauman et al.
 2005/0143756 A1 6/2005 Jankowski
 2005/0228413 A1 10/2005 Binmoeller et al.
 2005/0228446 A1 10/2005 Mooradian et al.
 2006/0030877 A1 2/2006 Martinez et al.
 2006/0129165 A1 6/2006 Edoga et al.
 2006/0229643 A1 10/2006 Nolan et al.
 2006/0264986 A1 11/2006 Park et al.
 2007/0005084 A1 1/2007 Clague et al.
 2007/0021840 A1 1/2007 Lopera

FOREIGN PATENT DOCUMENTS

EP 0 419 660 A1 4/1989
 EP 0 449 394 B1 10/1991
 EP 0 282 157 B1 1/1993
 FR 2689749 10/1993
 WO WO 87/06448 11/1987
 WO WO 90/06085 6/1990
 WO WO 01/21060 A1 3/2001
 WO WO 02/00121 A1 1/2002
 WO WO 2007/147439 A1 12/2007

* cited by examiner

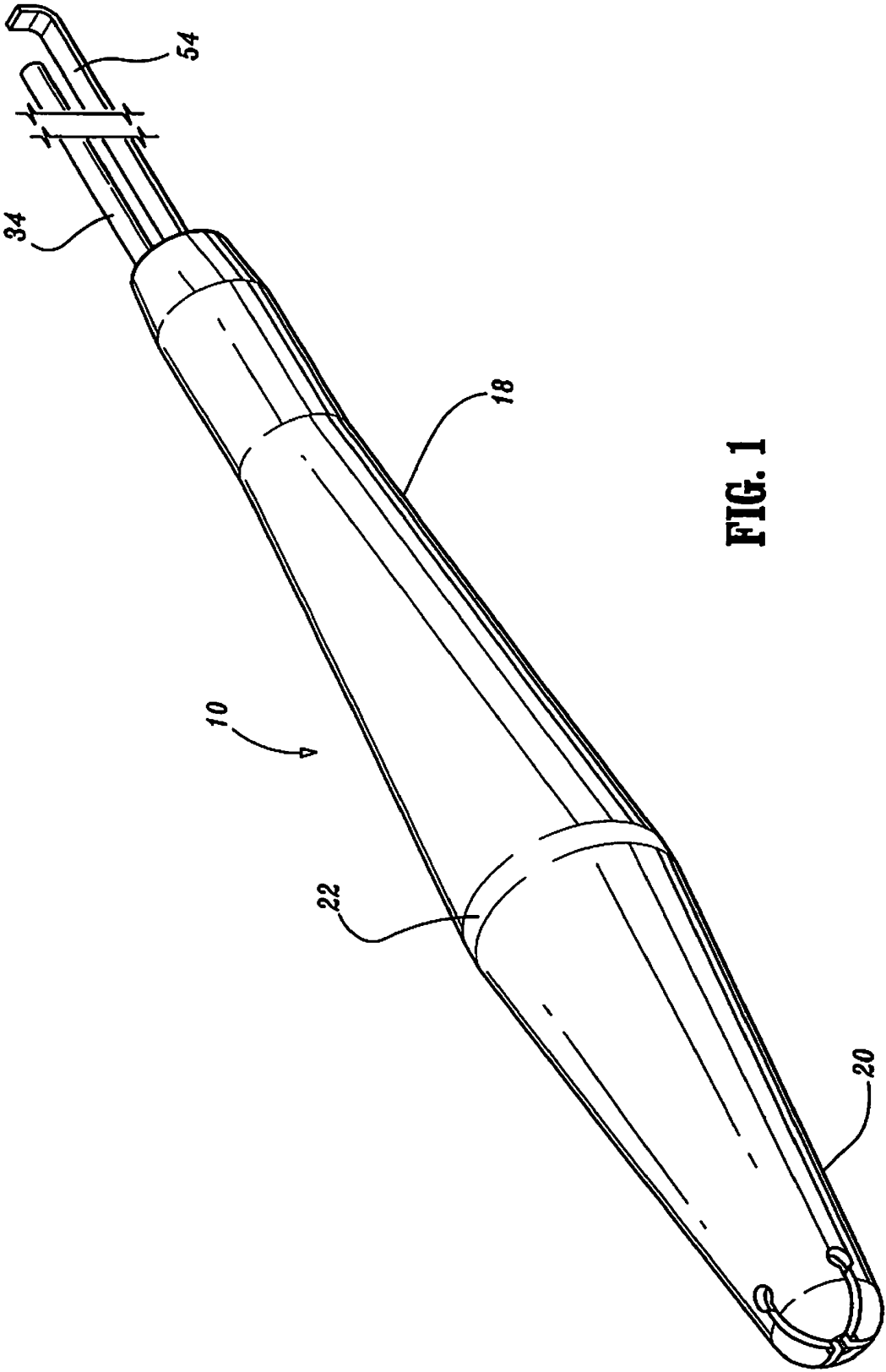

FIG. 1

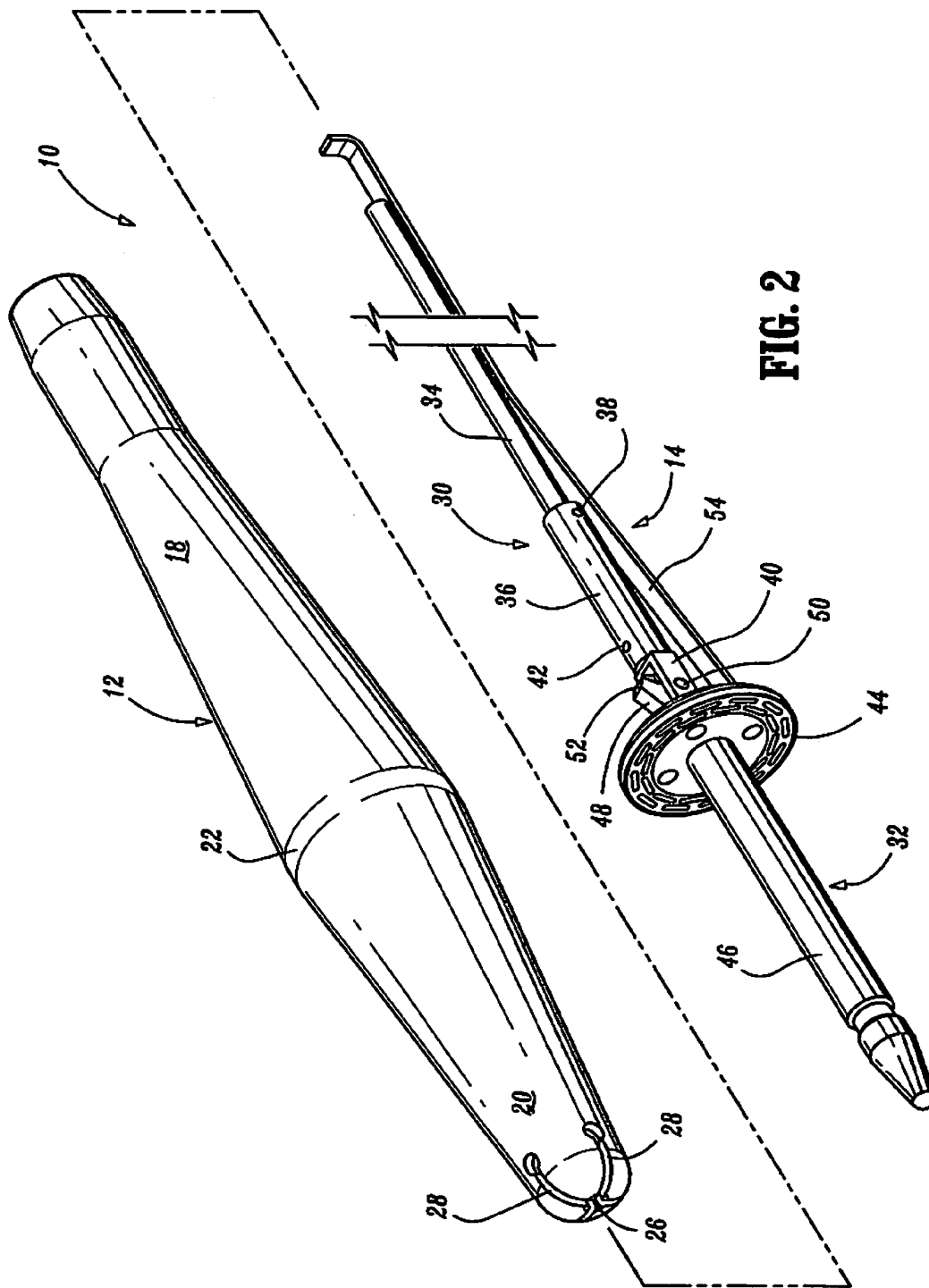

FIG. 2

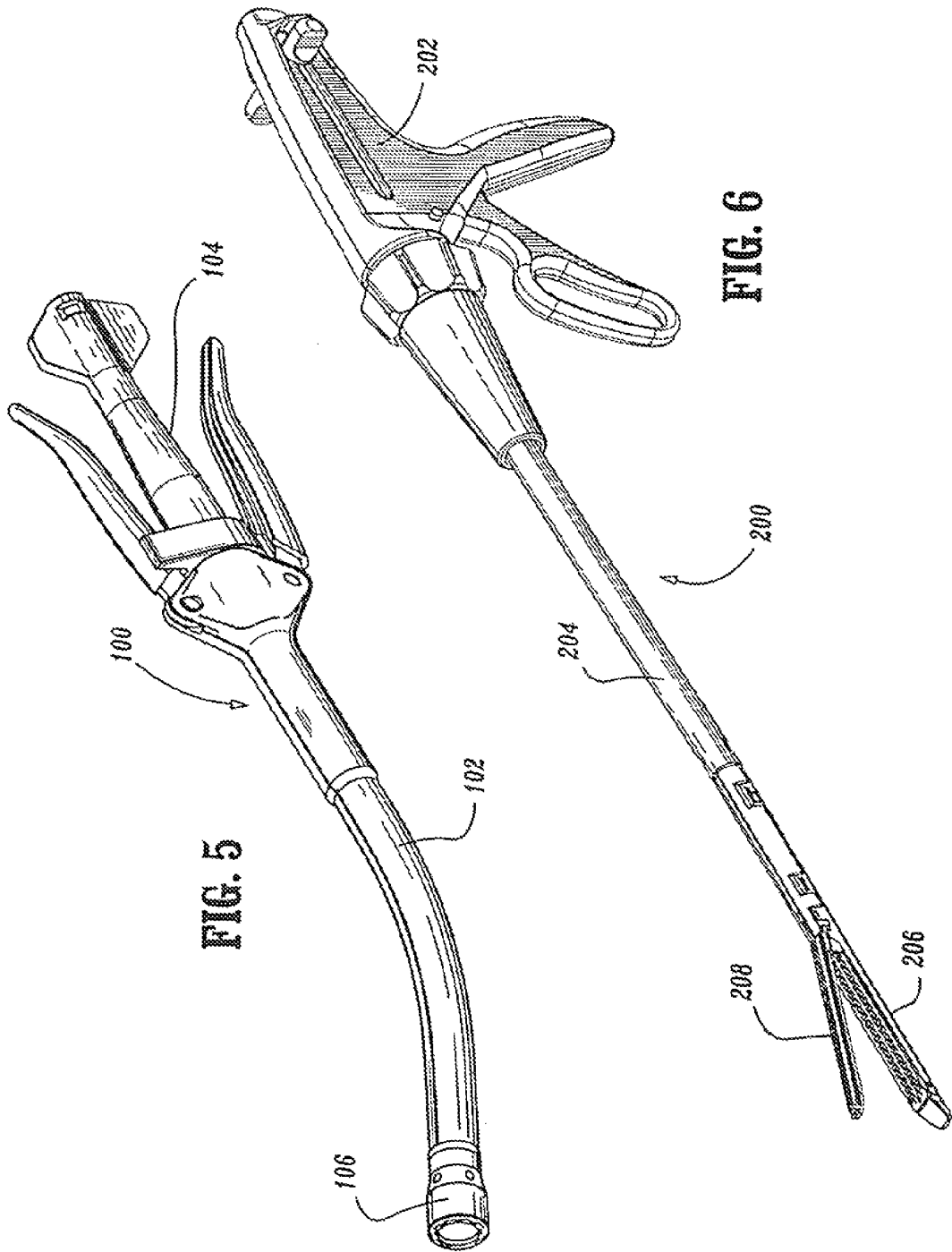

FIG. 5

FIG. 6

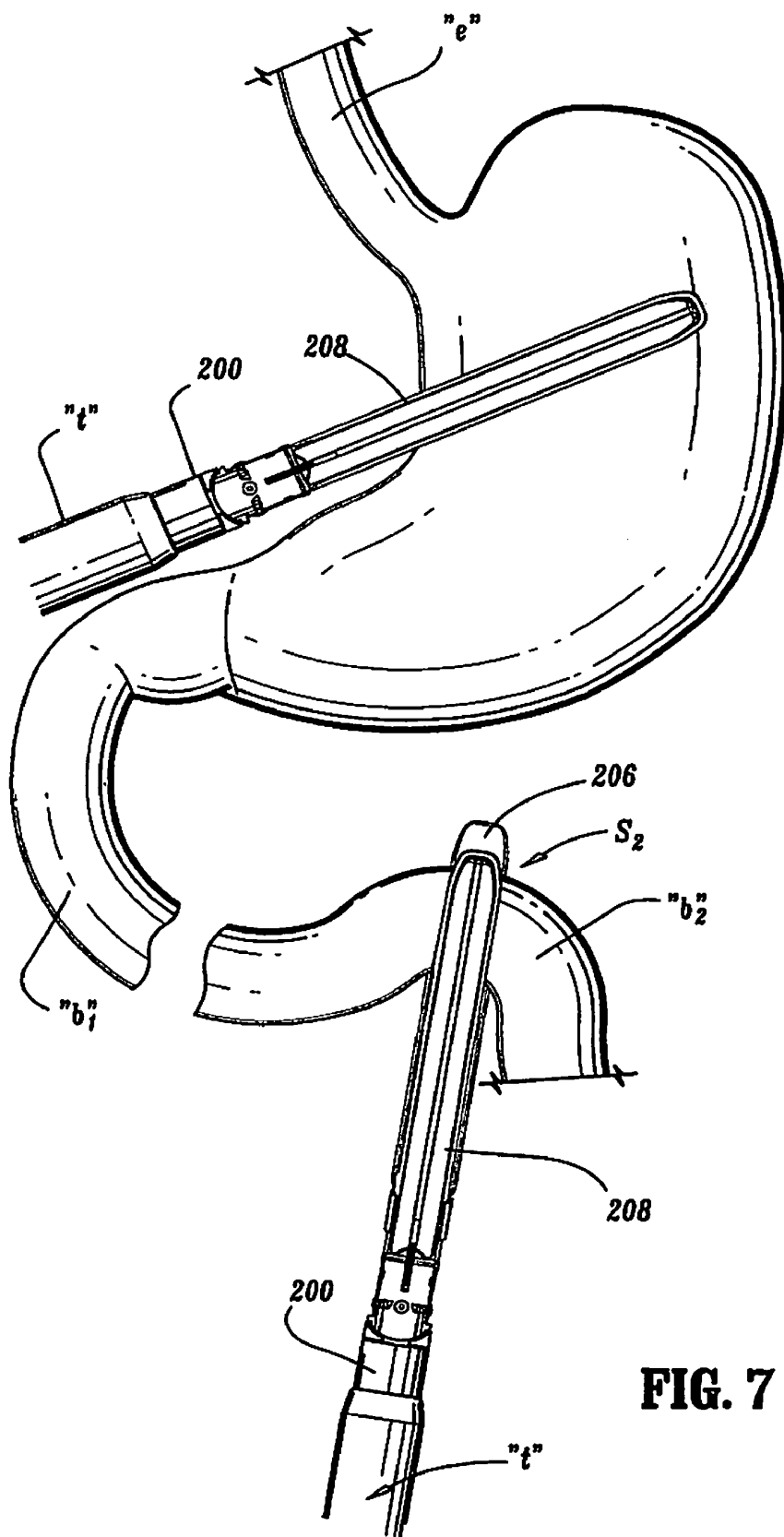
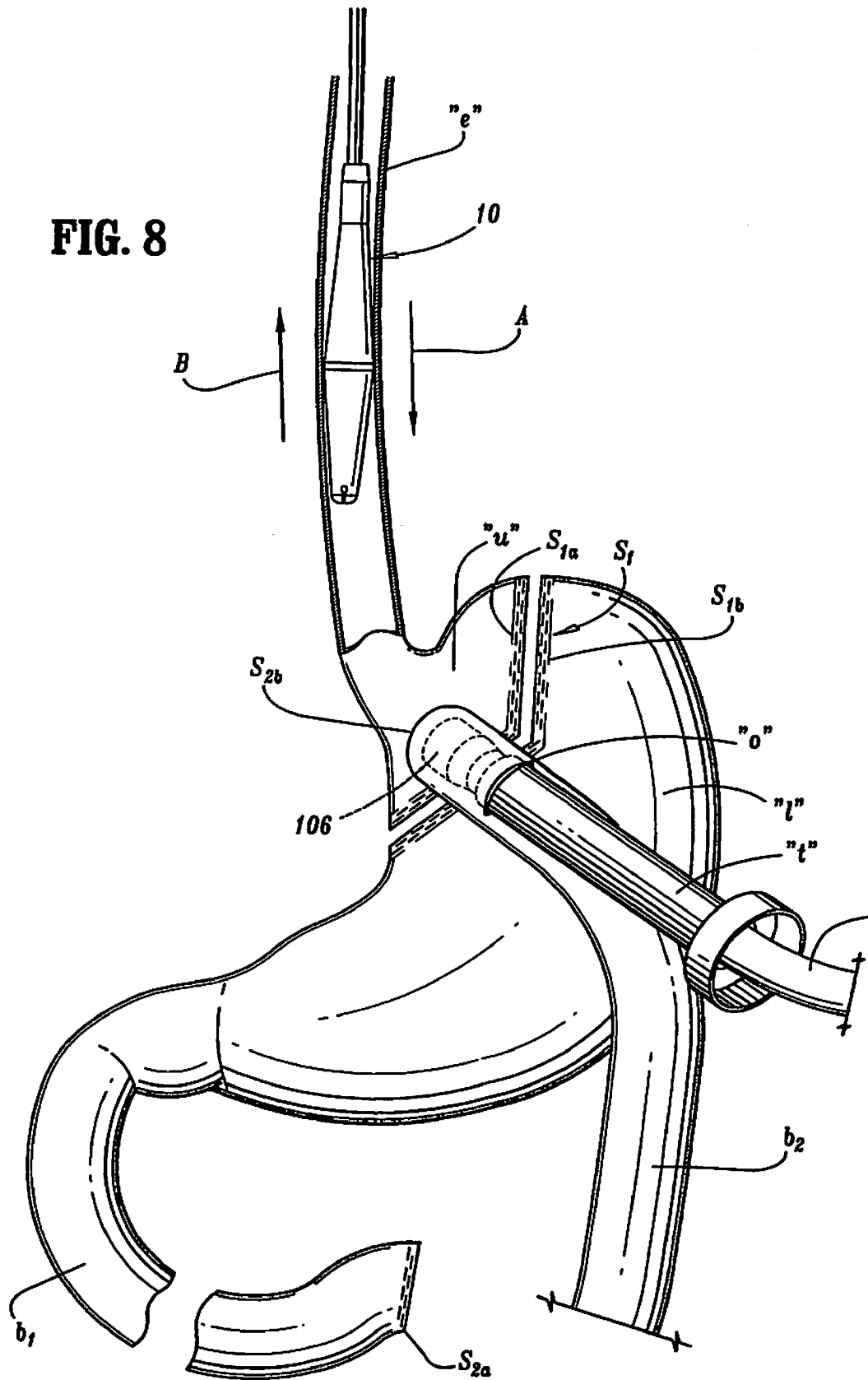

FIG. 7

FIG. 8



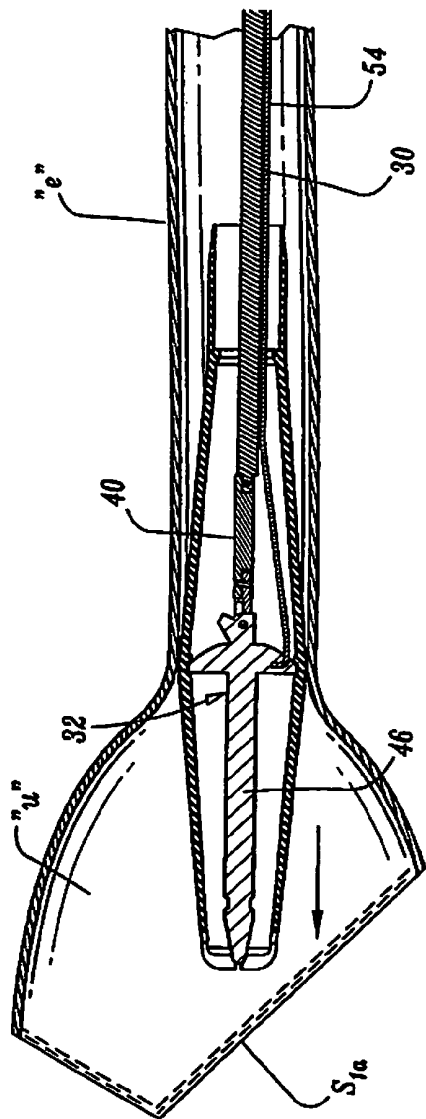

FIG. 9

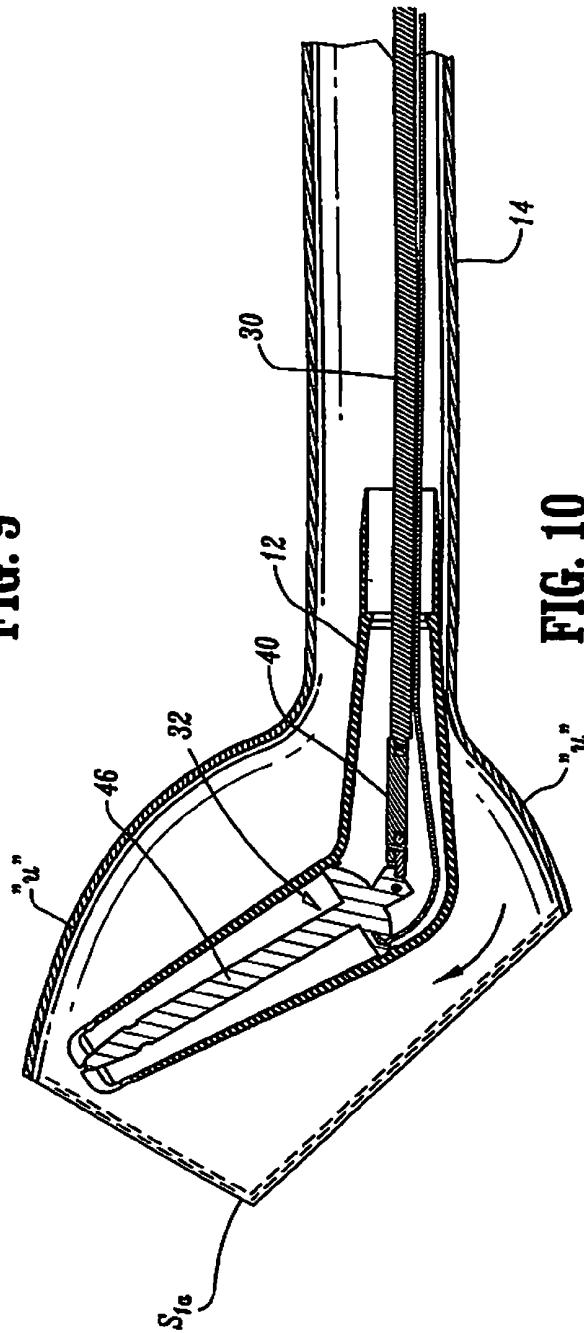

FIG. 10

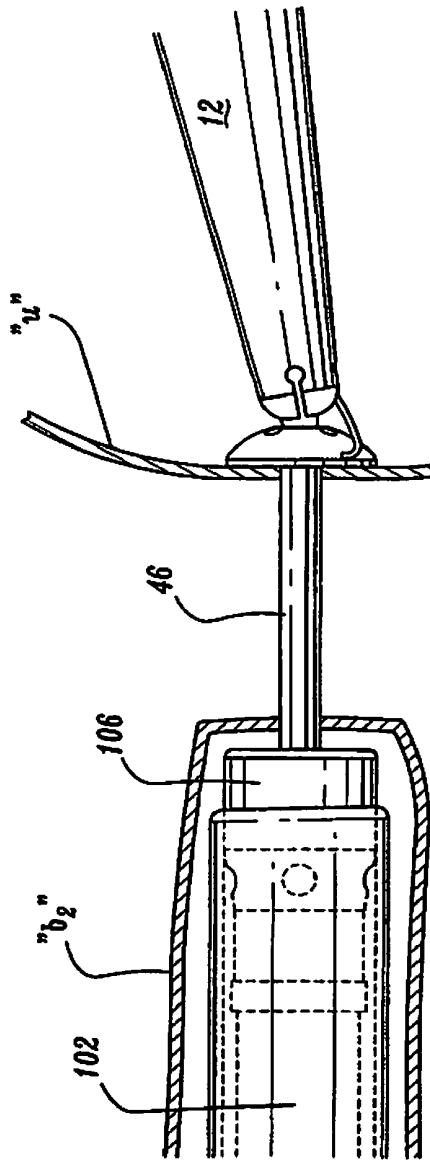

FIG. 13

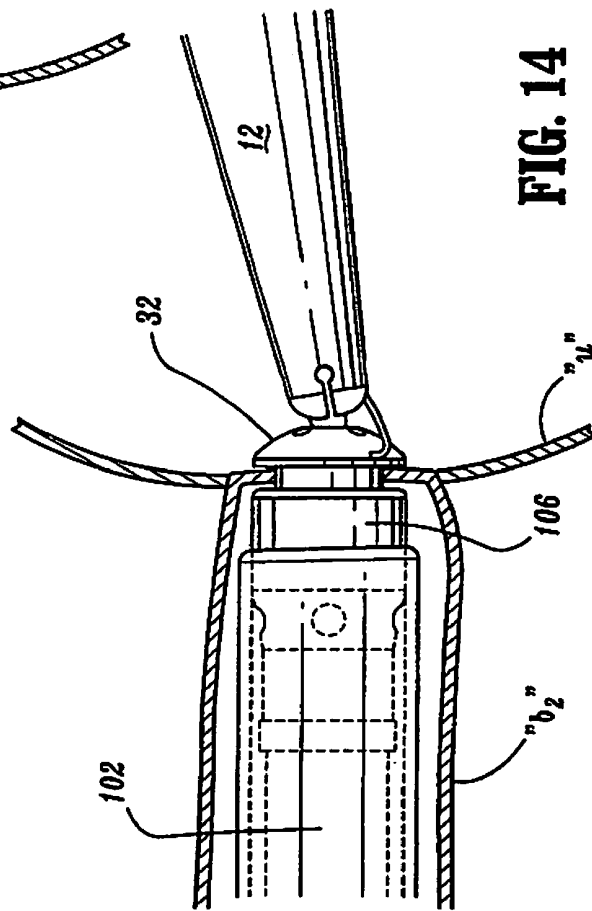

FIG. 14

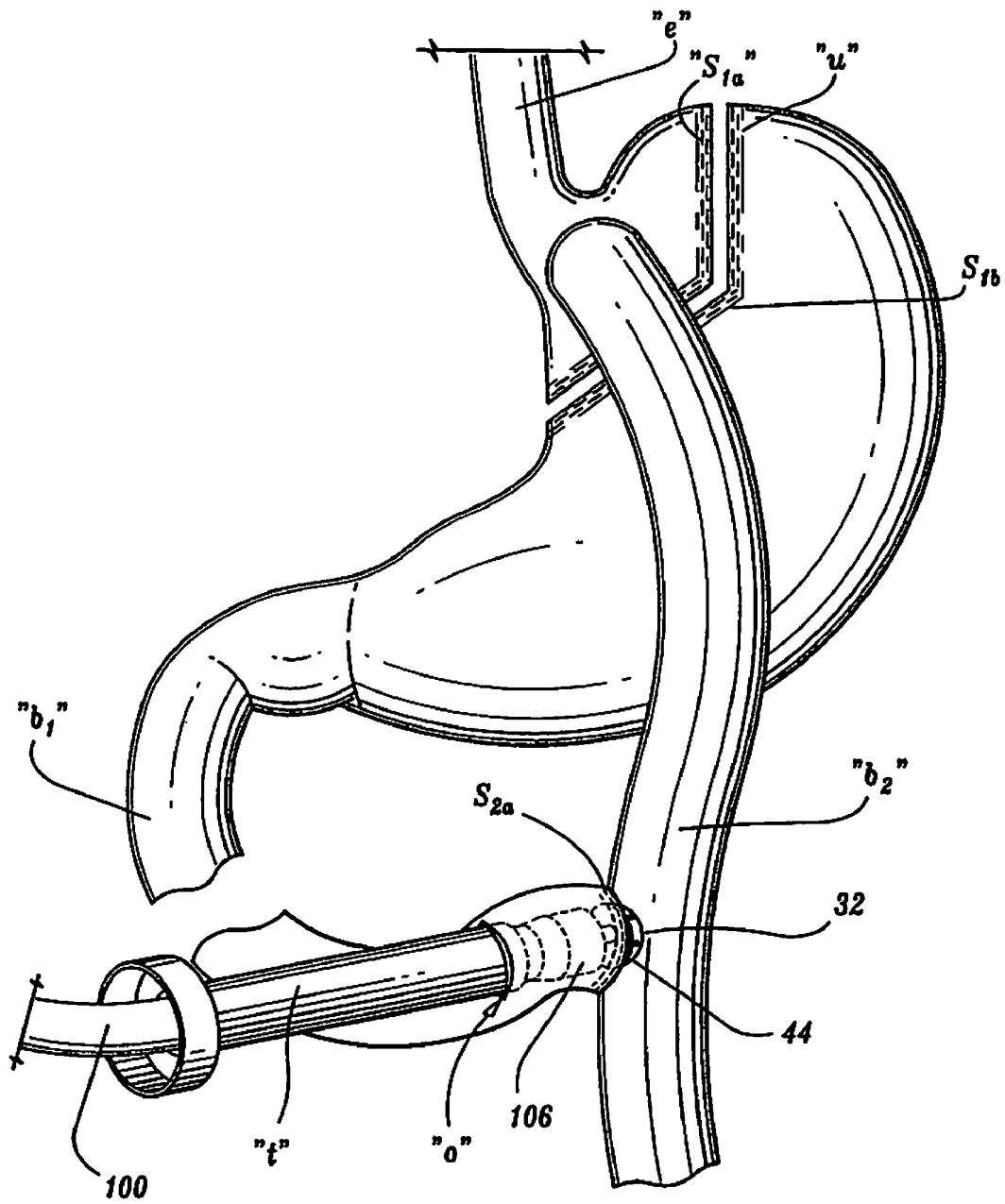

FIG. 16

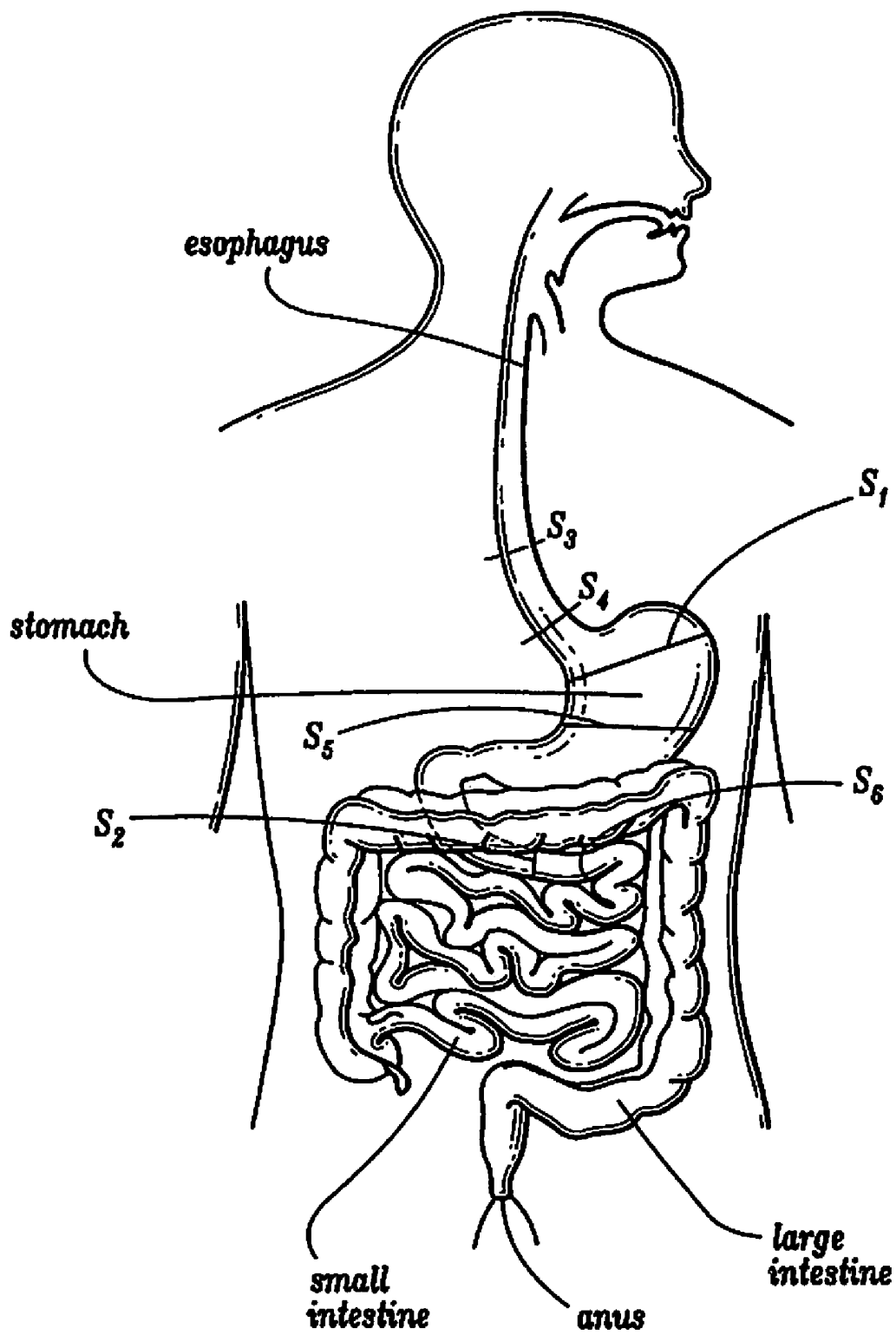

FIG. 17

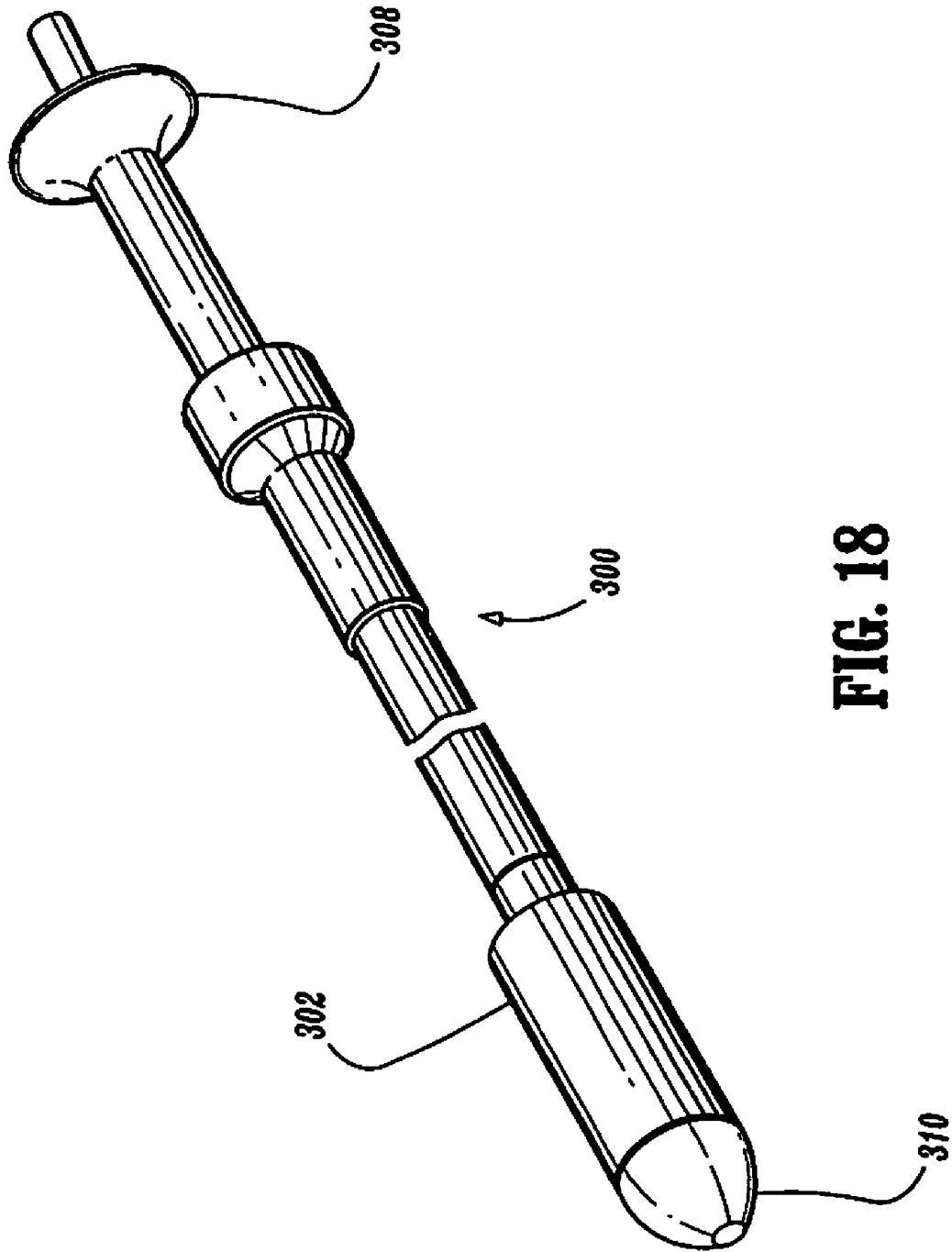

FIG. 18

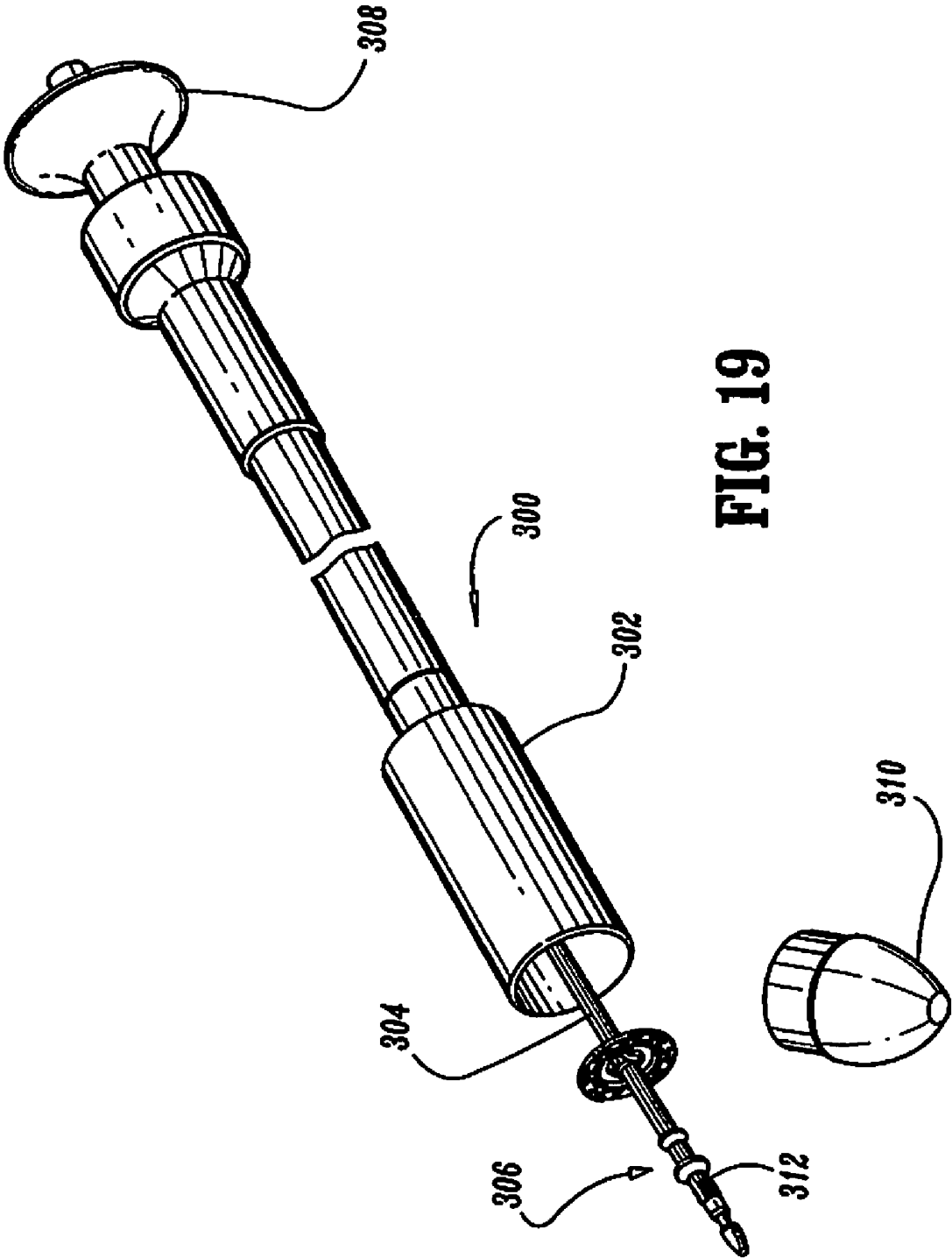

FIG. 19

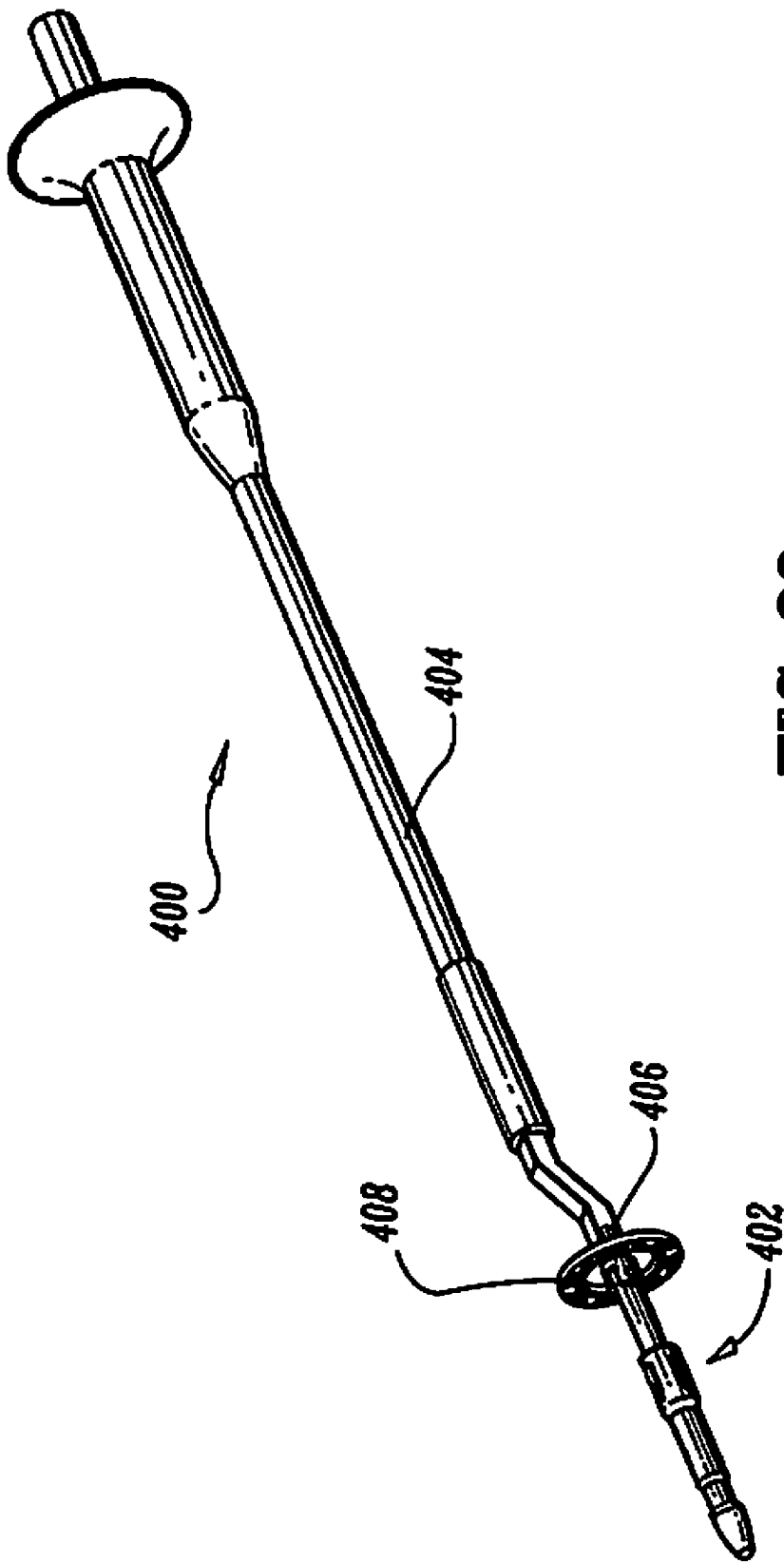

FIG. 20

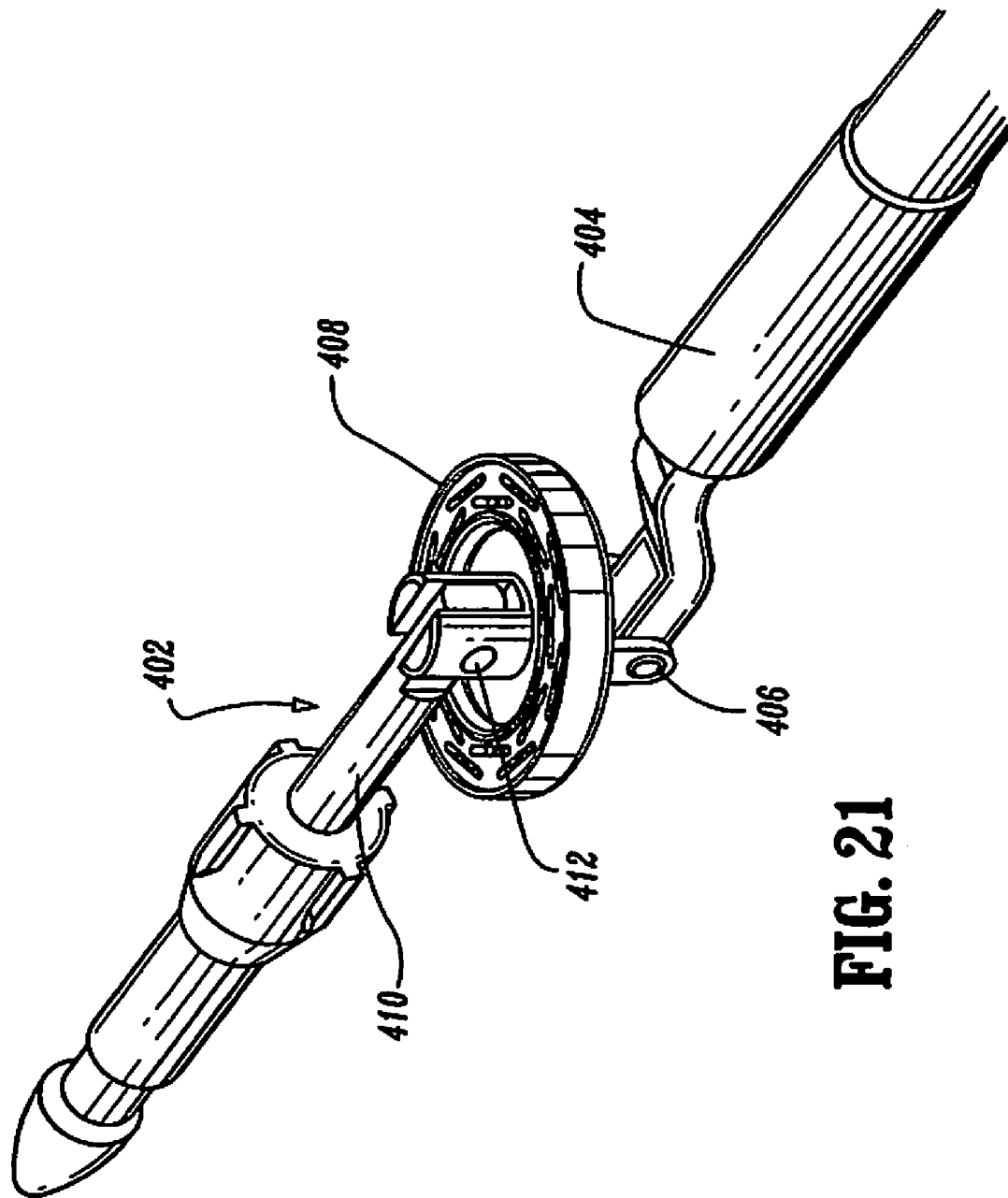

FIG. 21

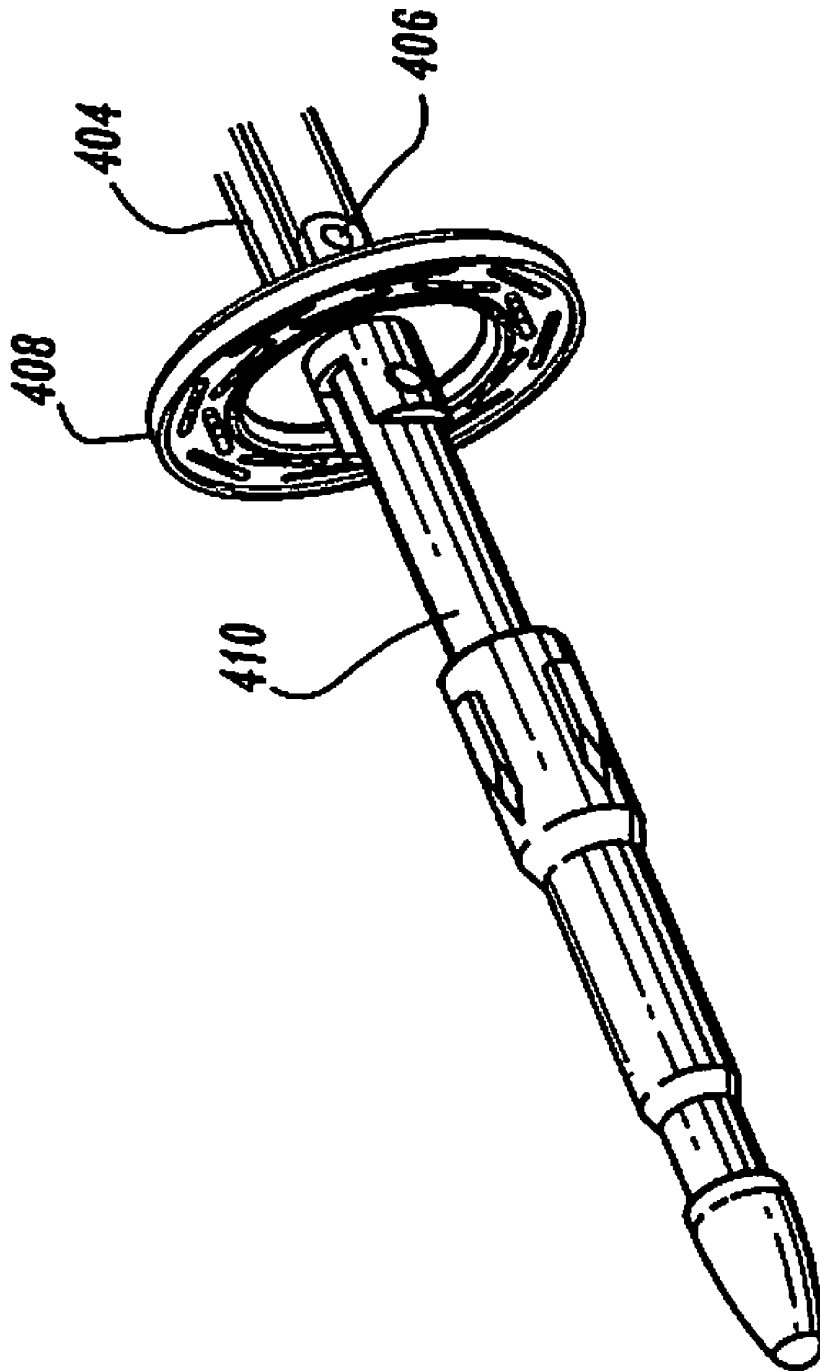

FIG. 22

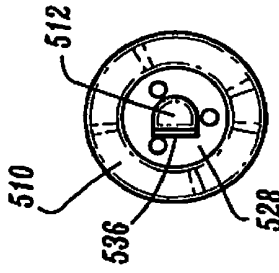

FIG. 24

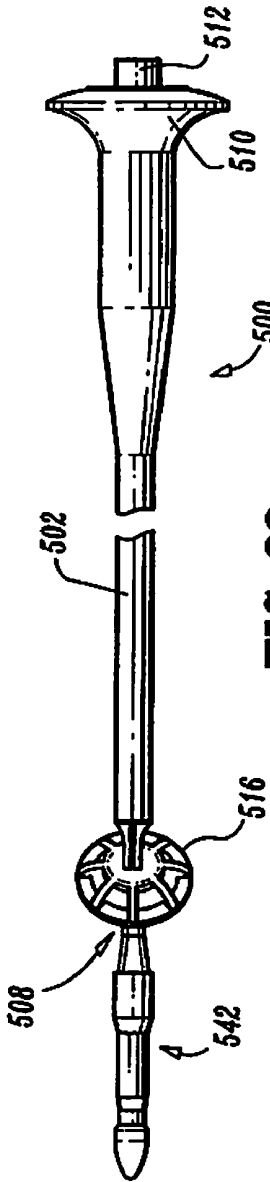

FIG. 23

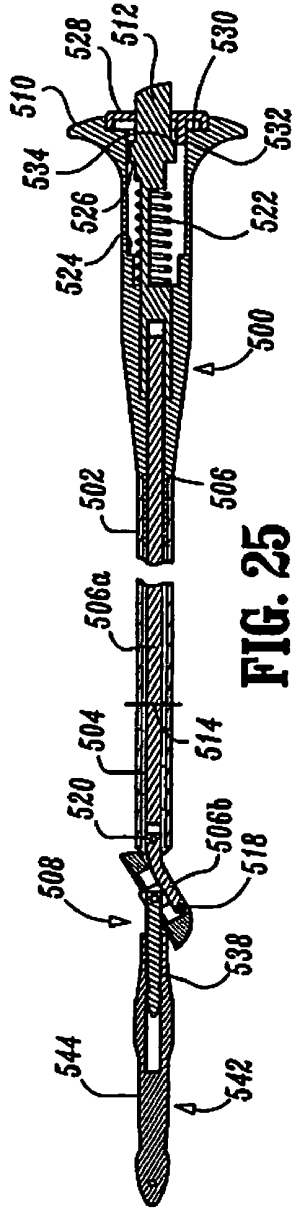

FIG. 25

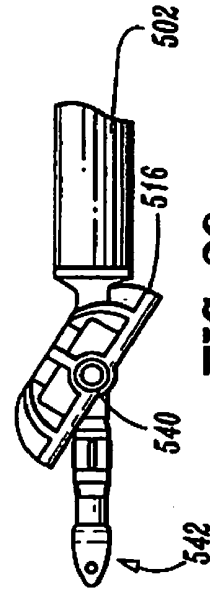

FIG. 26

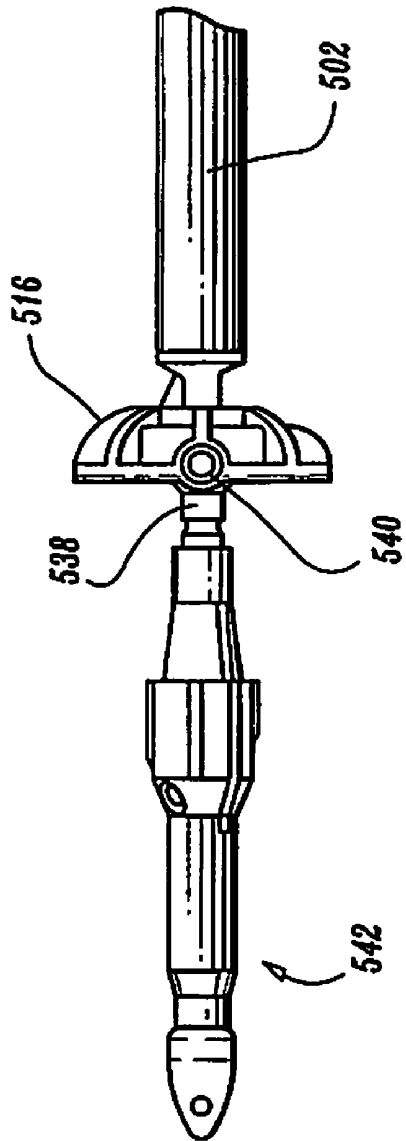

FIG. 27

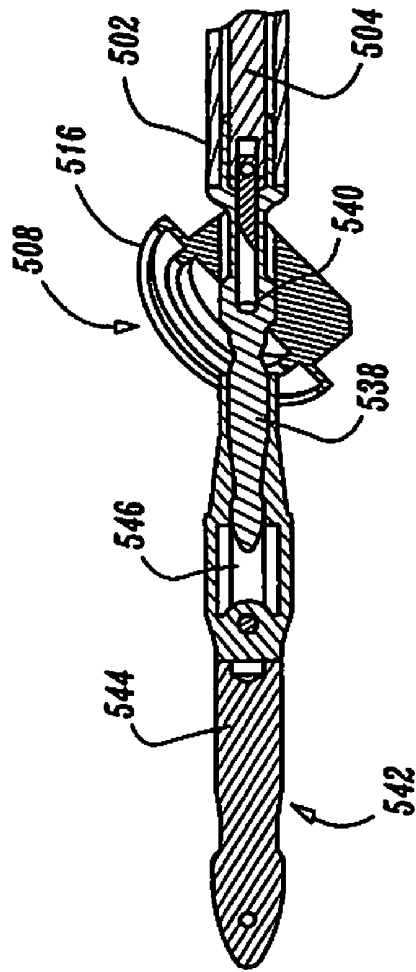

FIG. 28

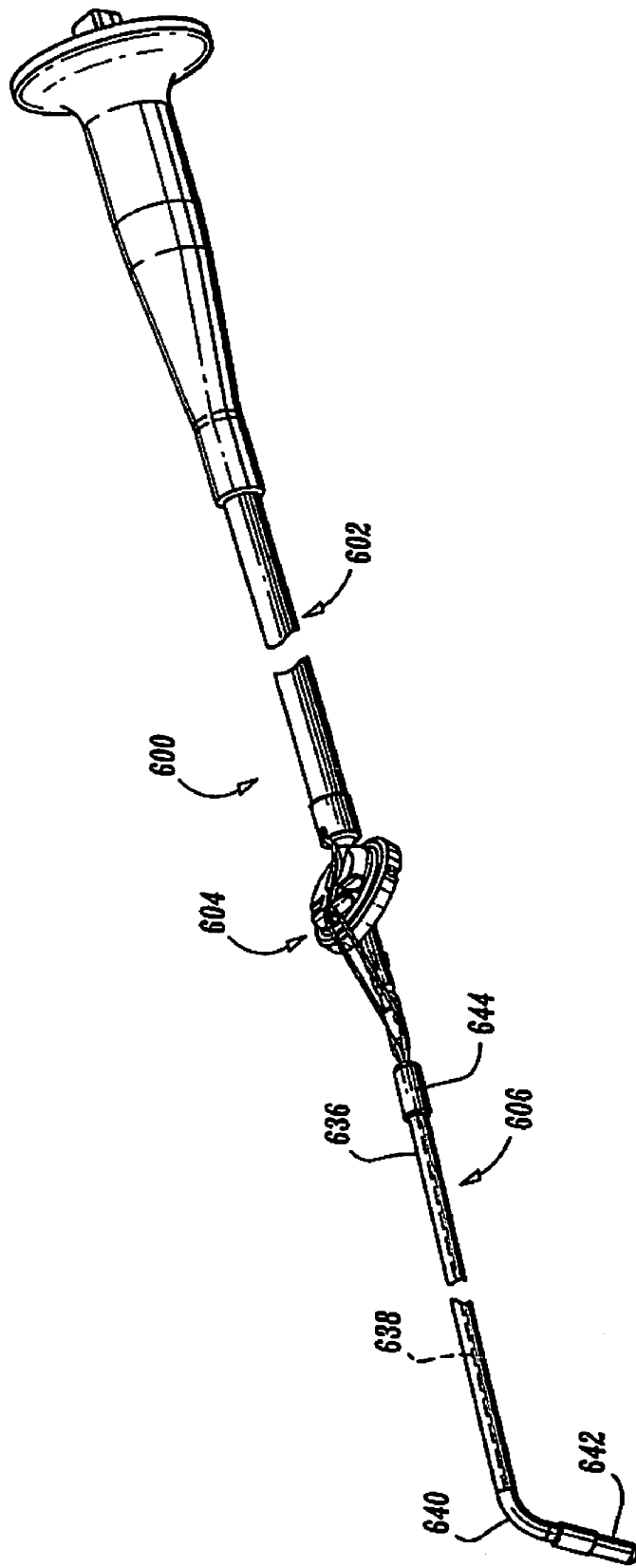

FIG. 29

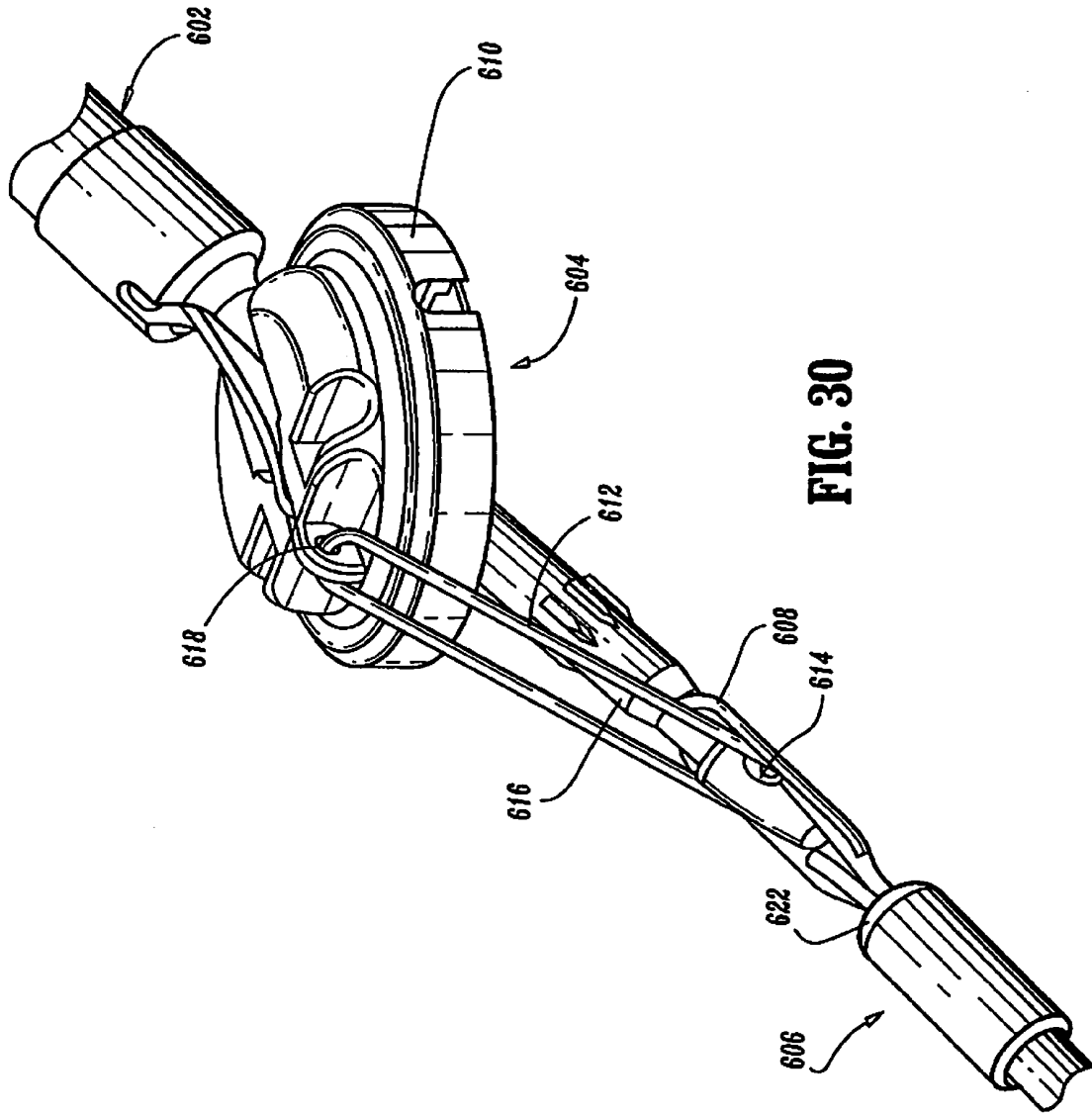

FIG. 30

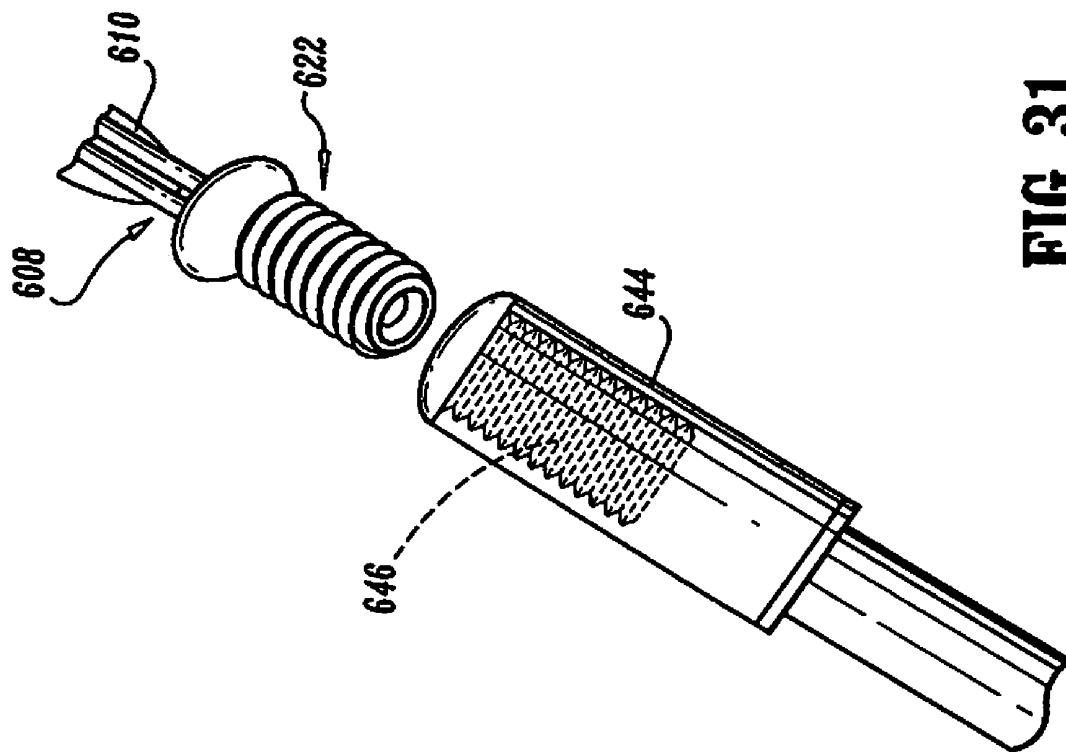

FIG. 31

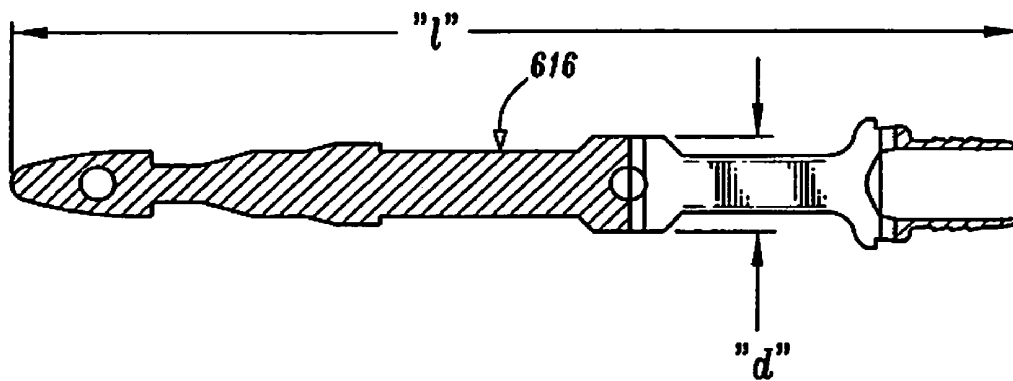

FIG. 32A

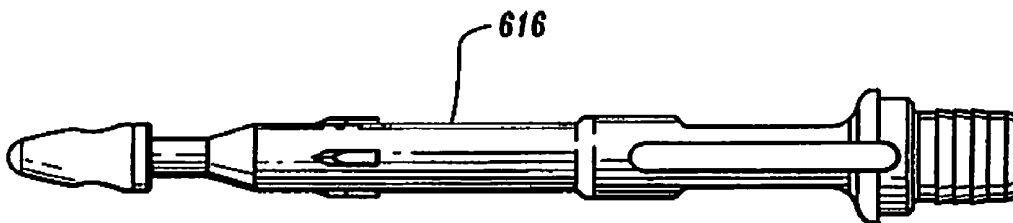

FIG. 32B

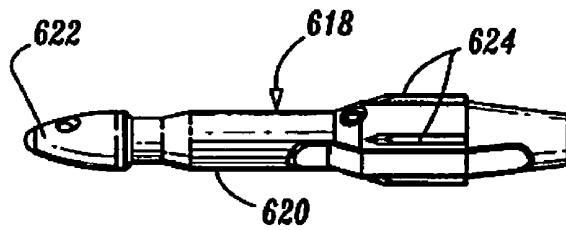

FIG. 33A

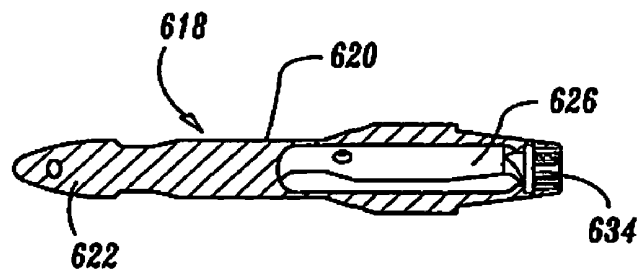

FIG. 33B

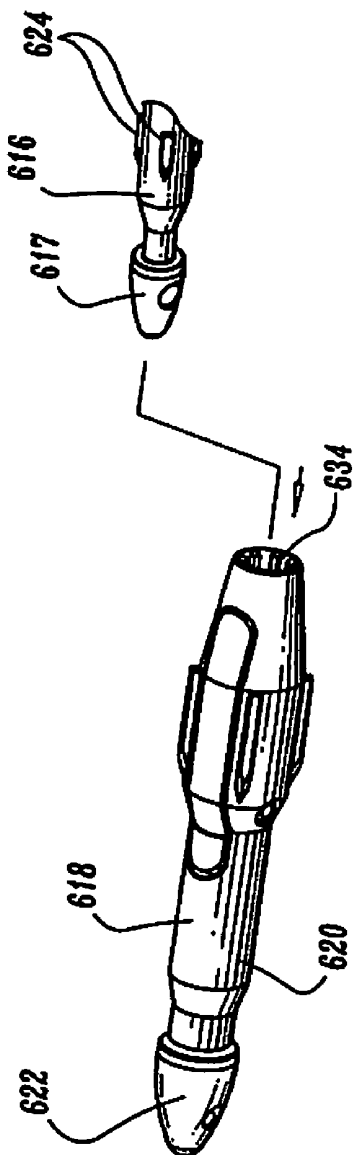

FIG. 34

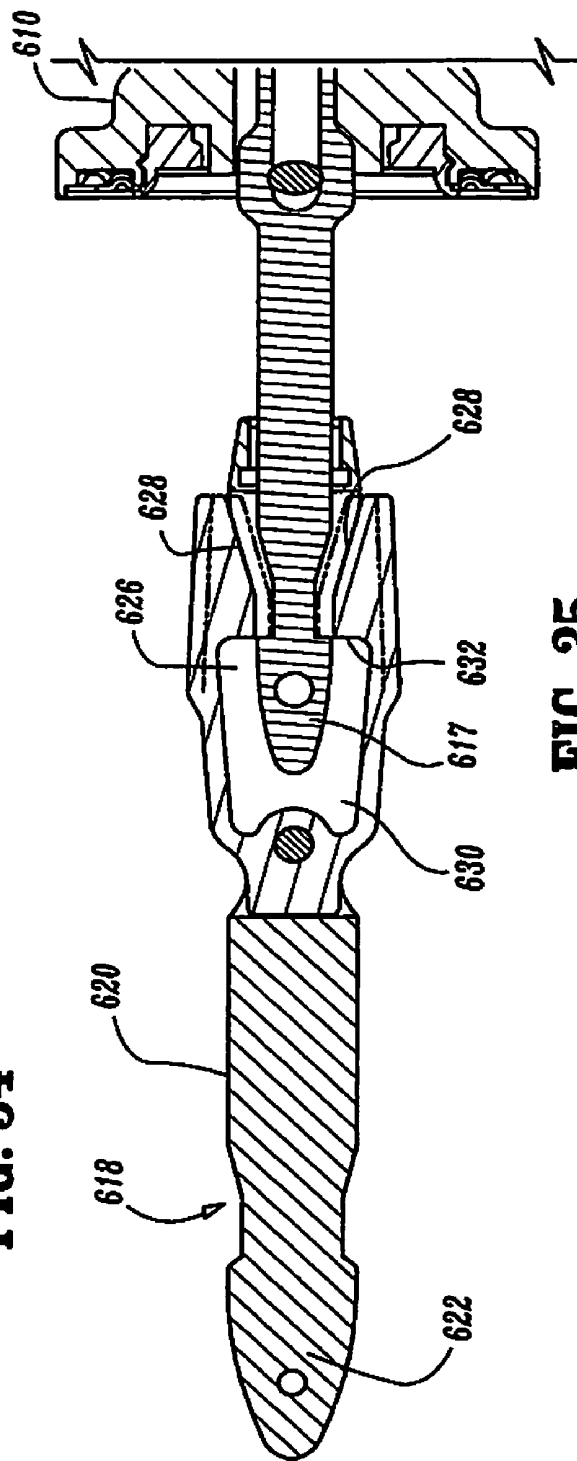

FIG. 35

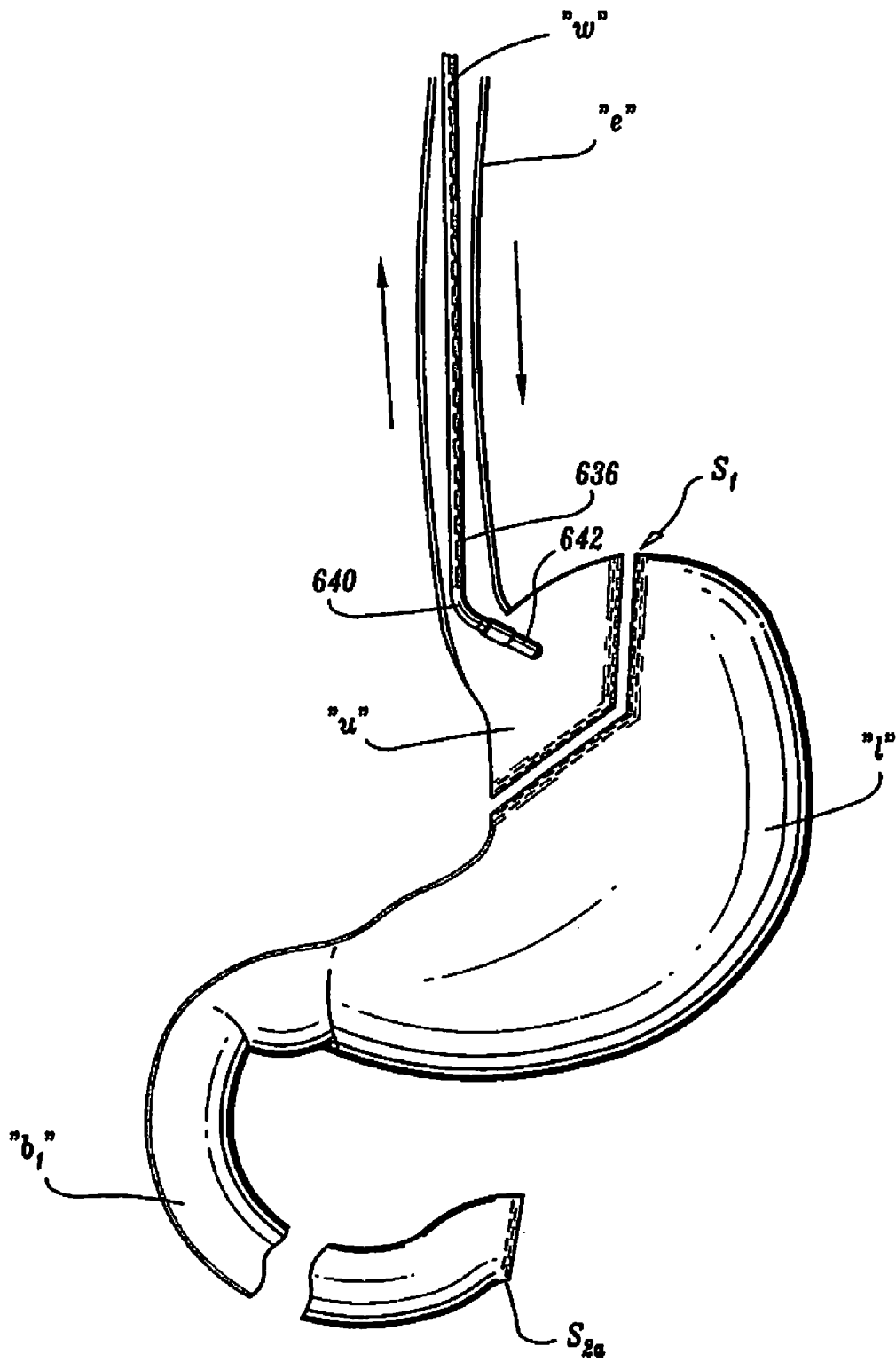

FIG. 36

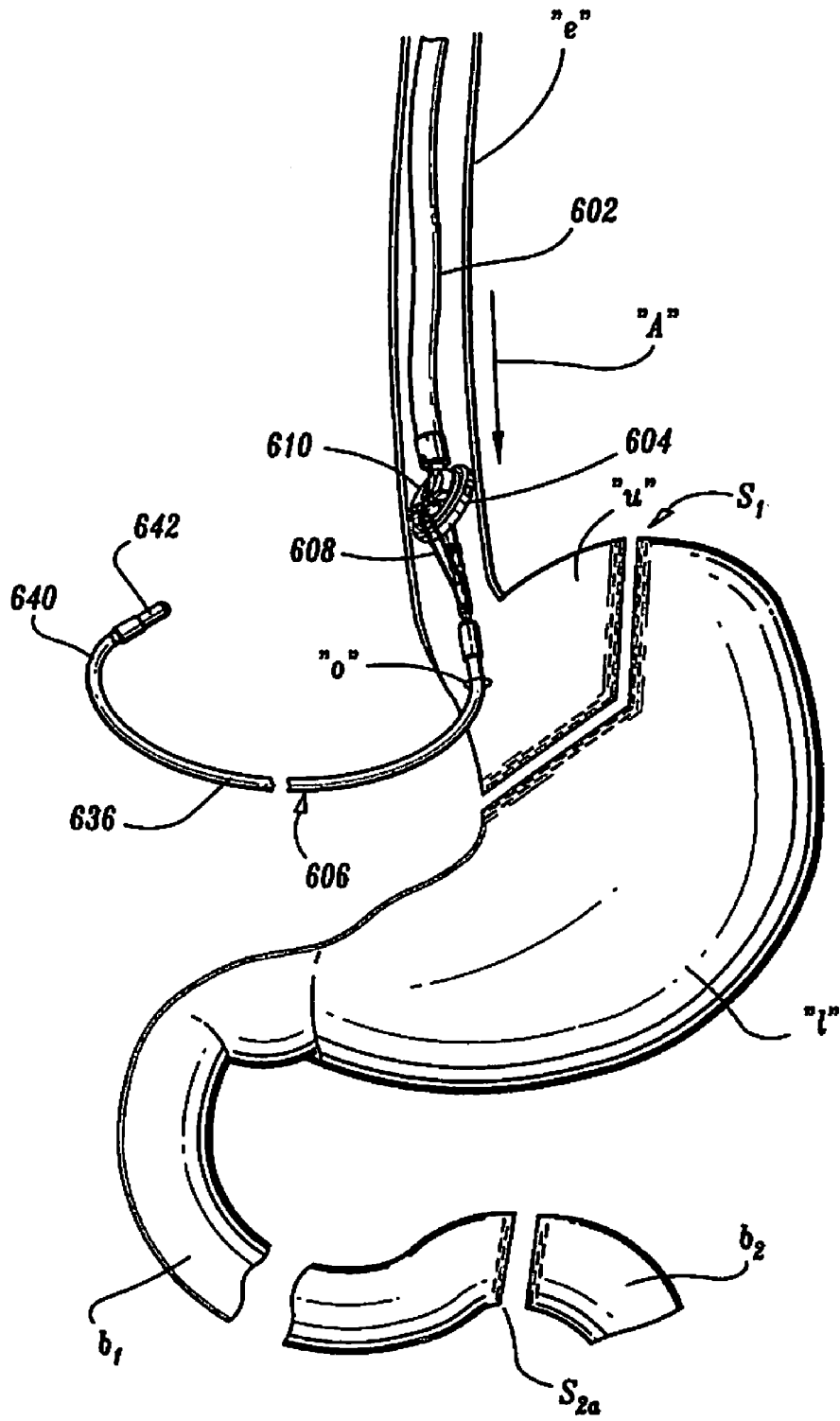

FIG. 37

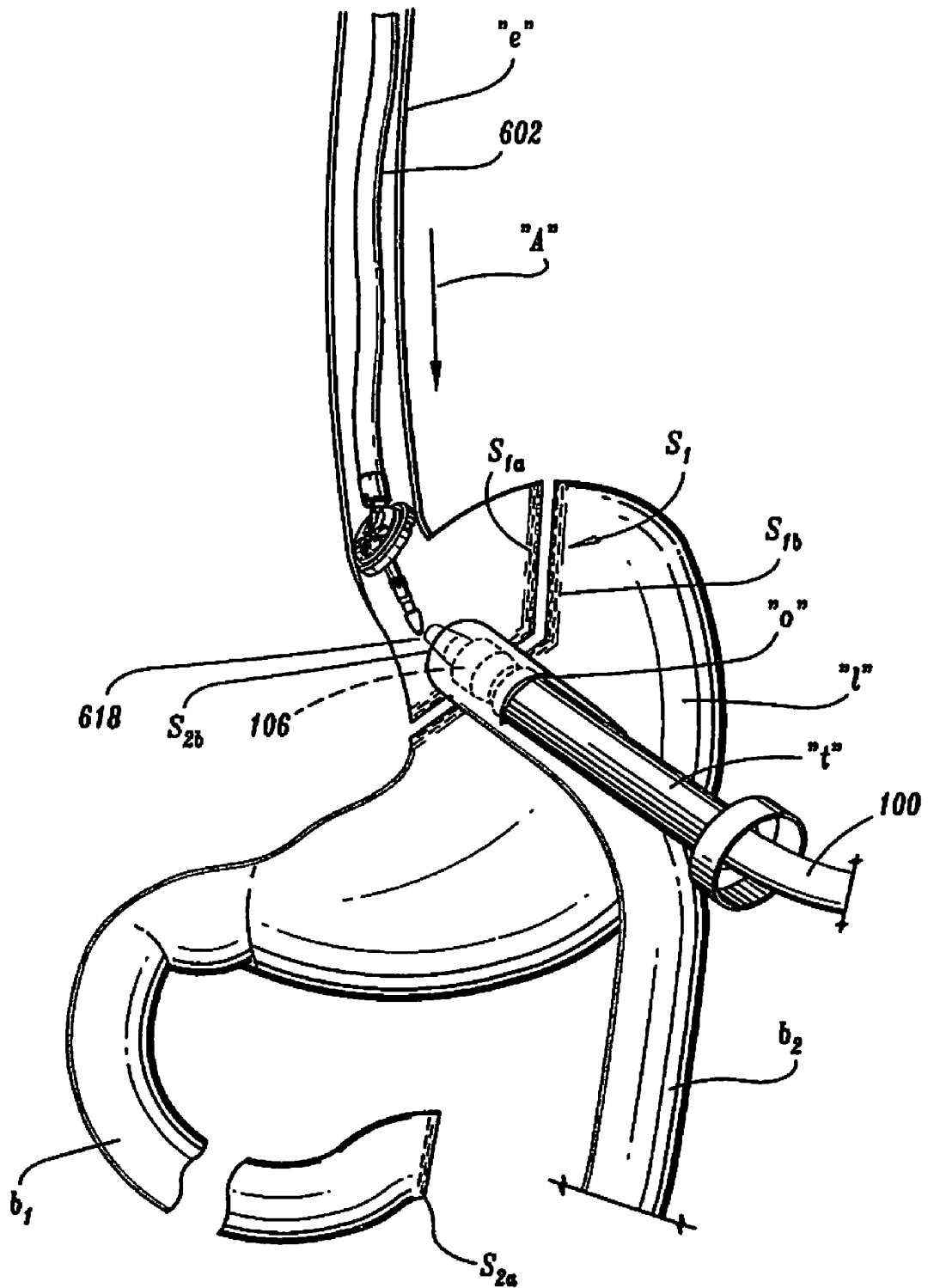

FIG. 38

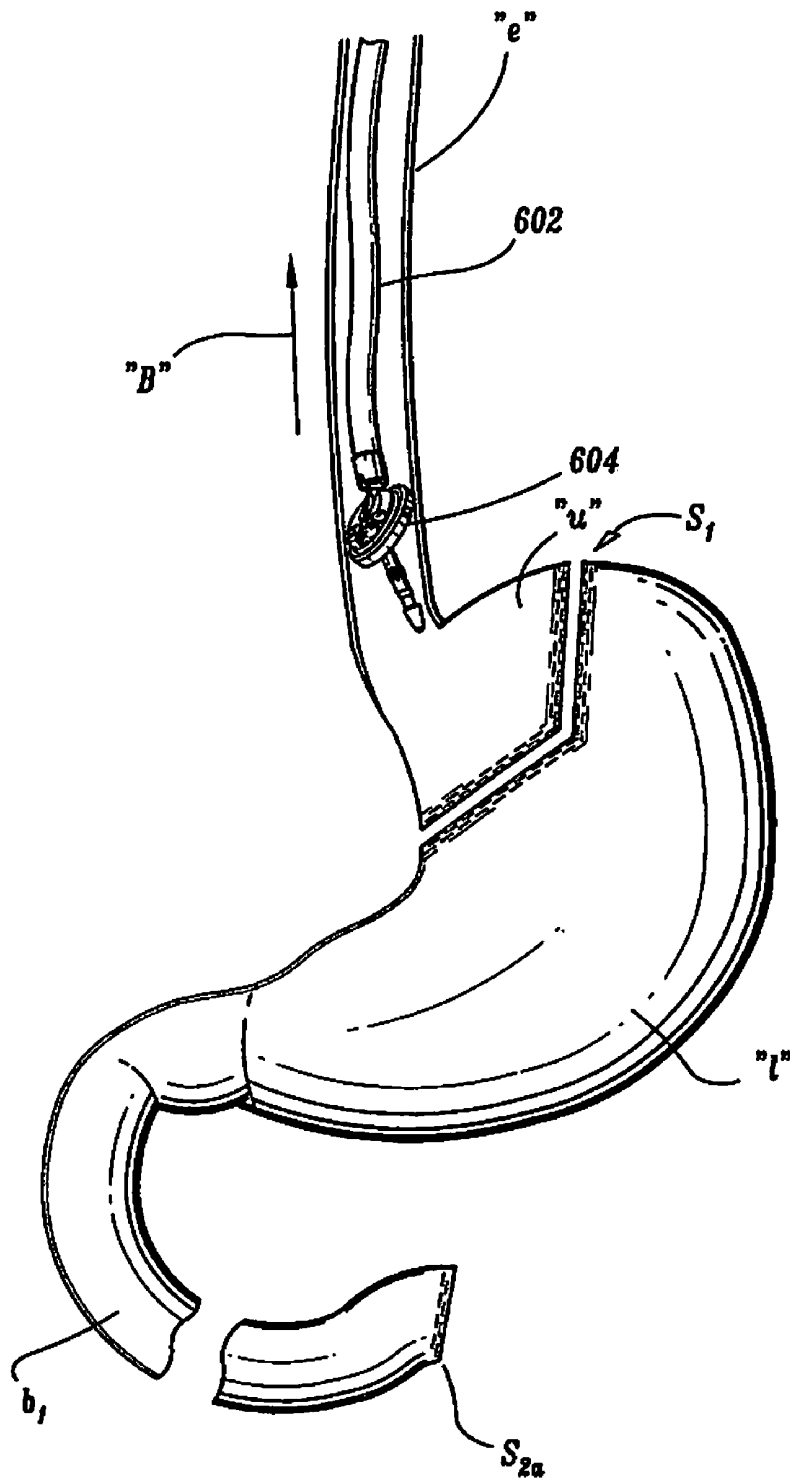

FIG. 39

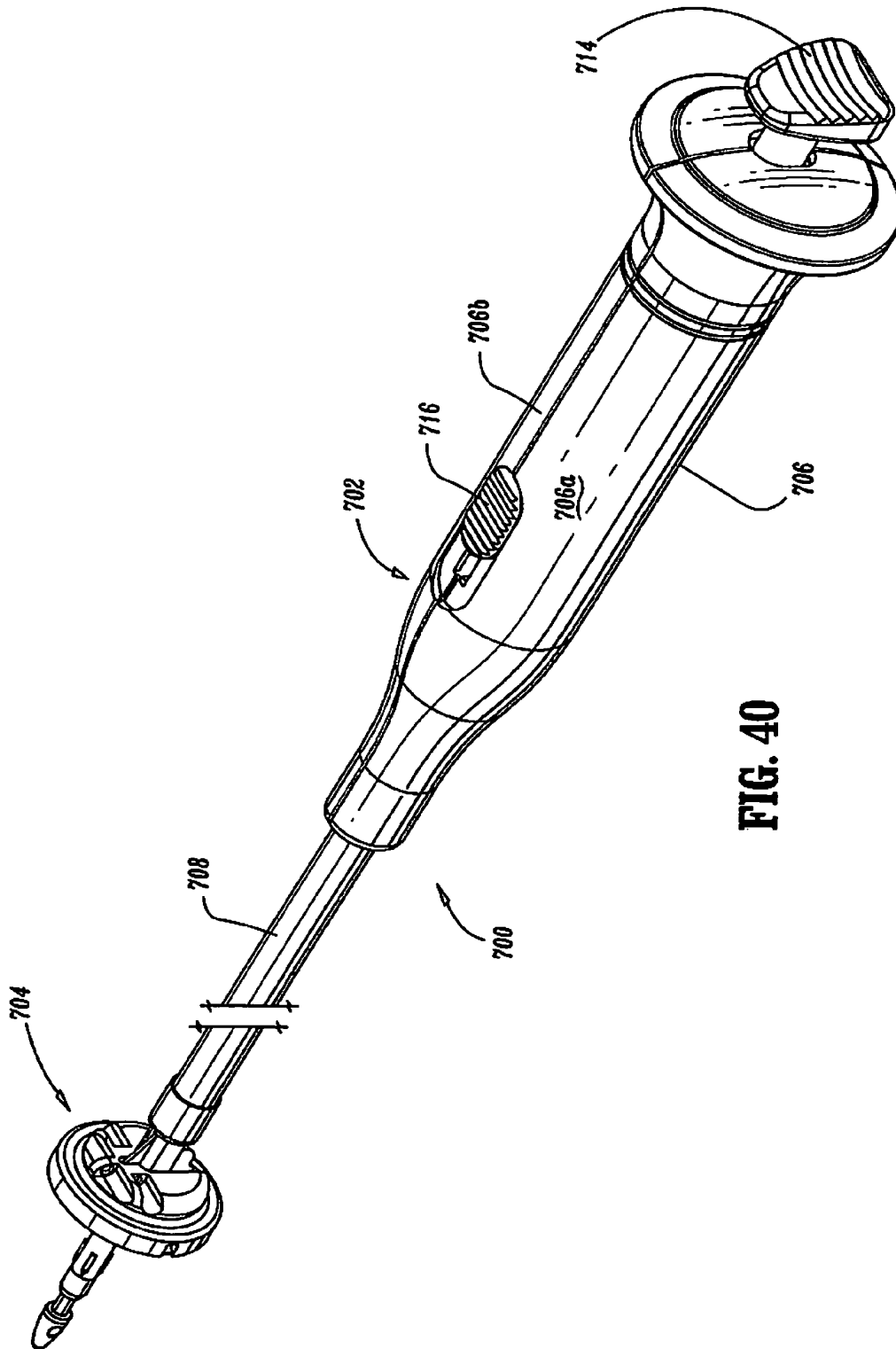

FIG. 40

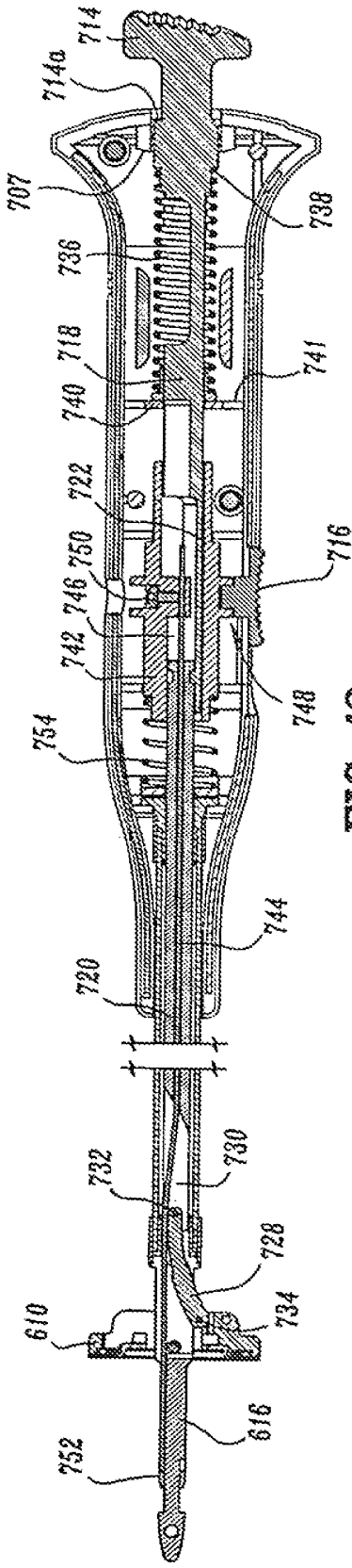

FIG. 42

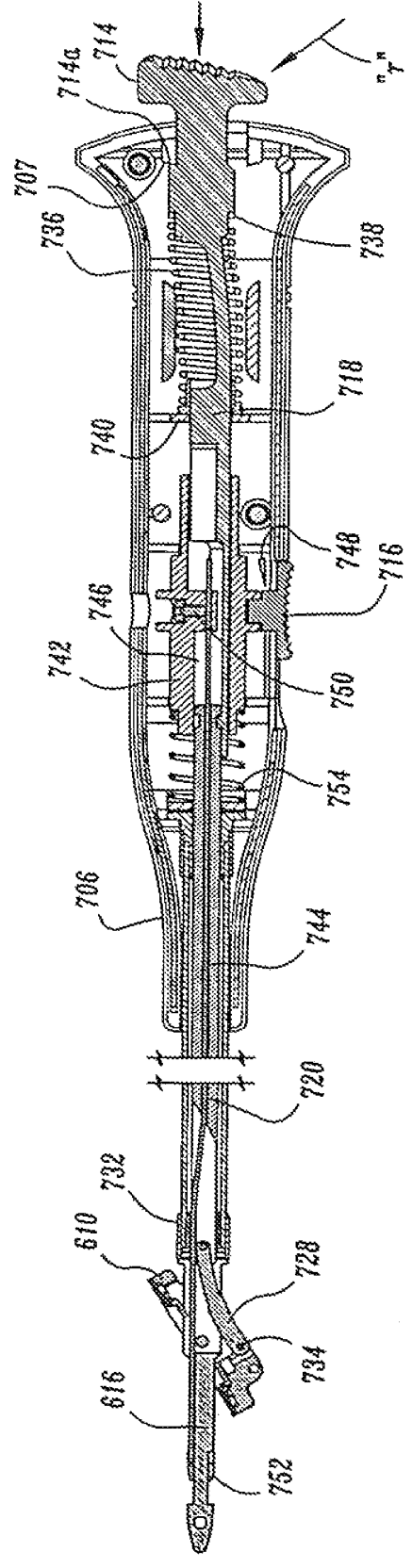

FIG. 43

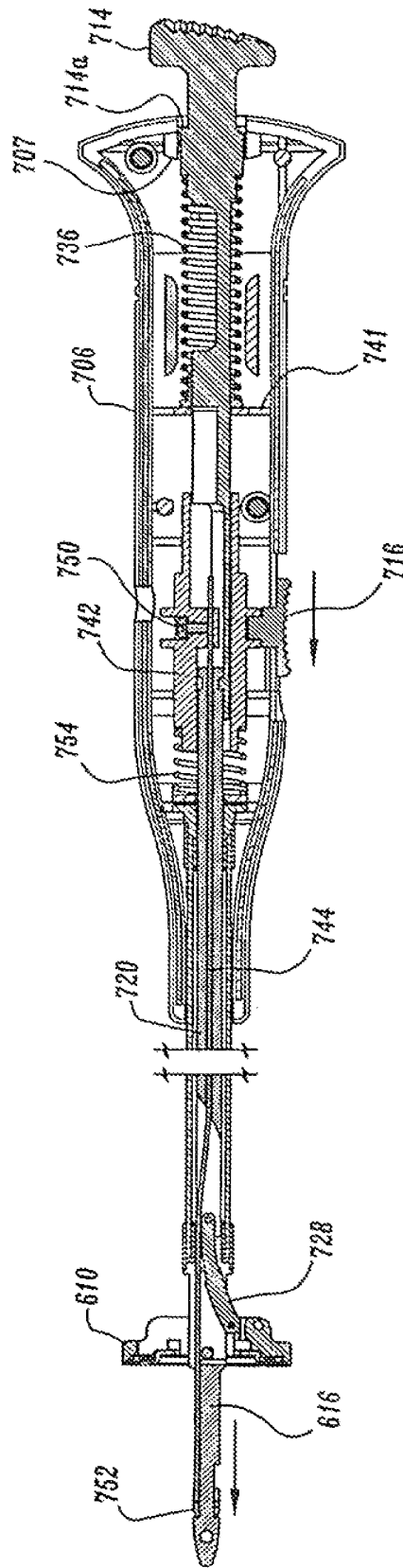
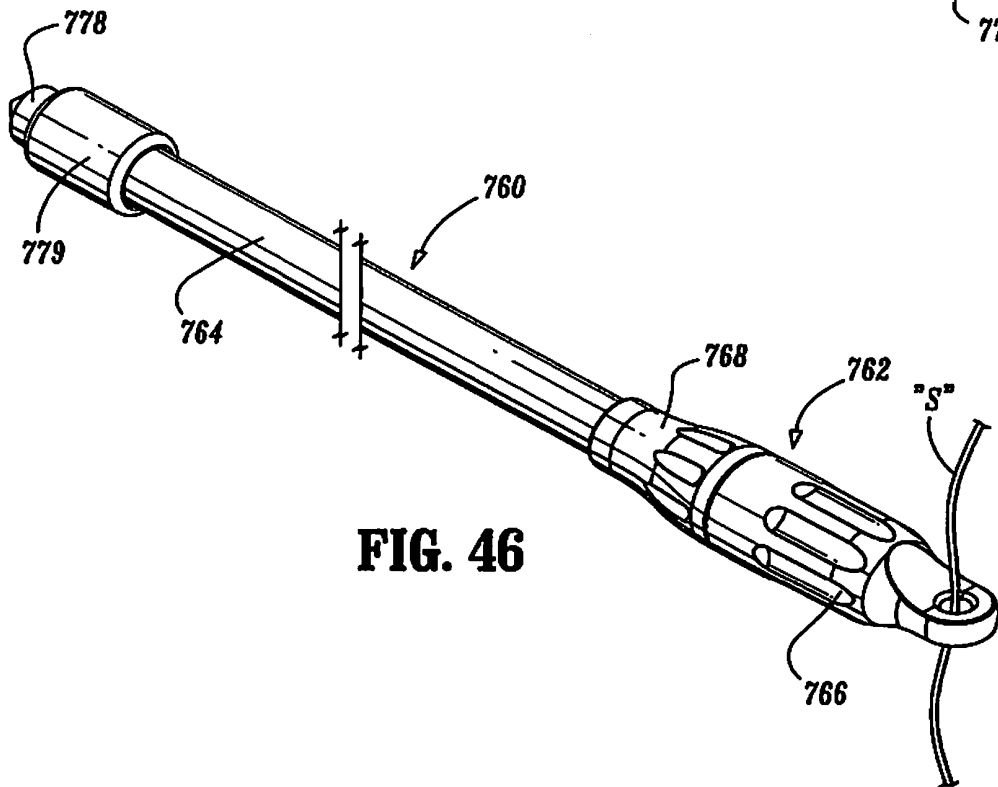
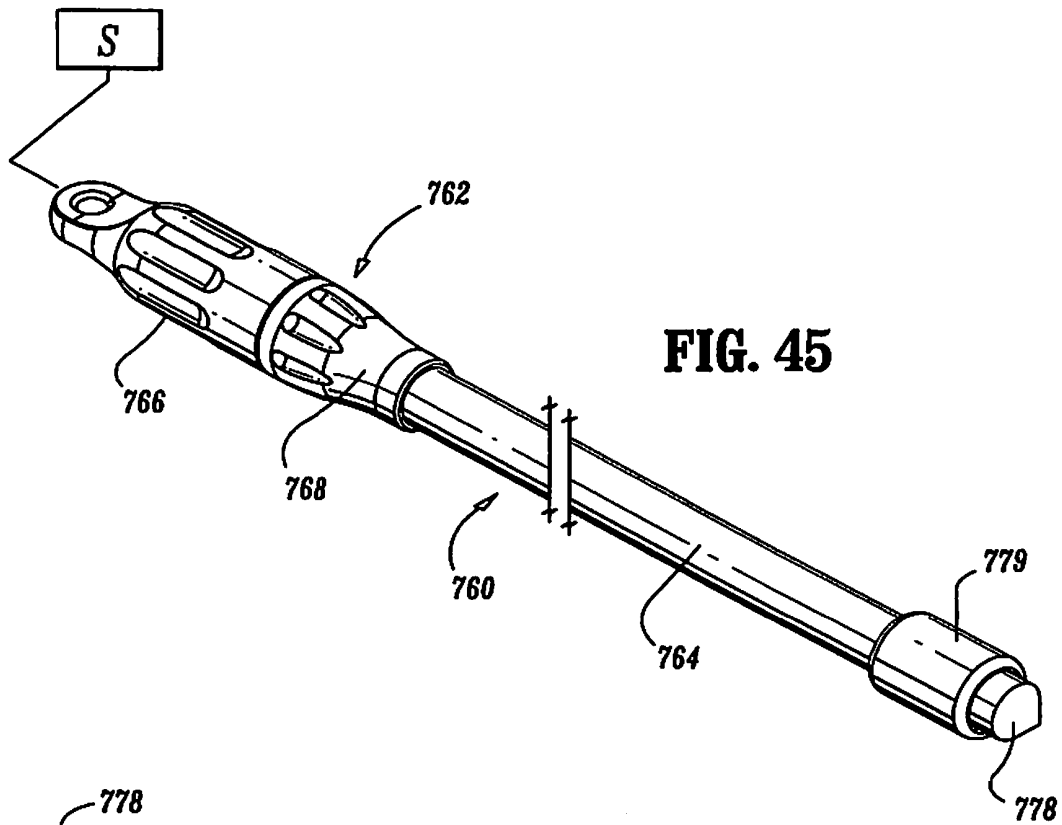

FIG. 44



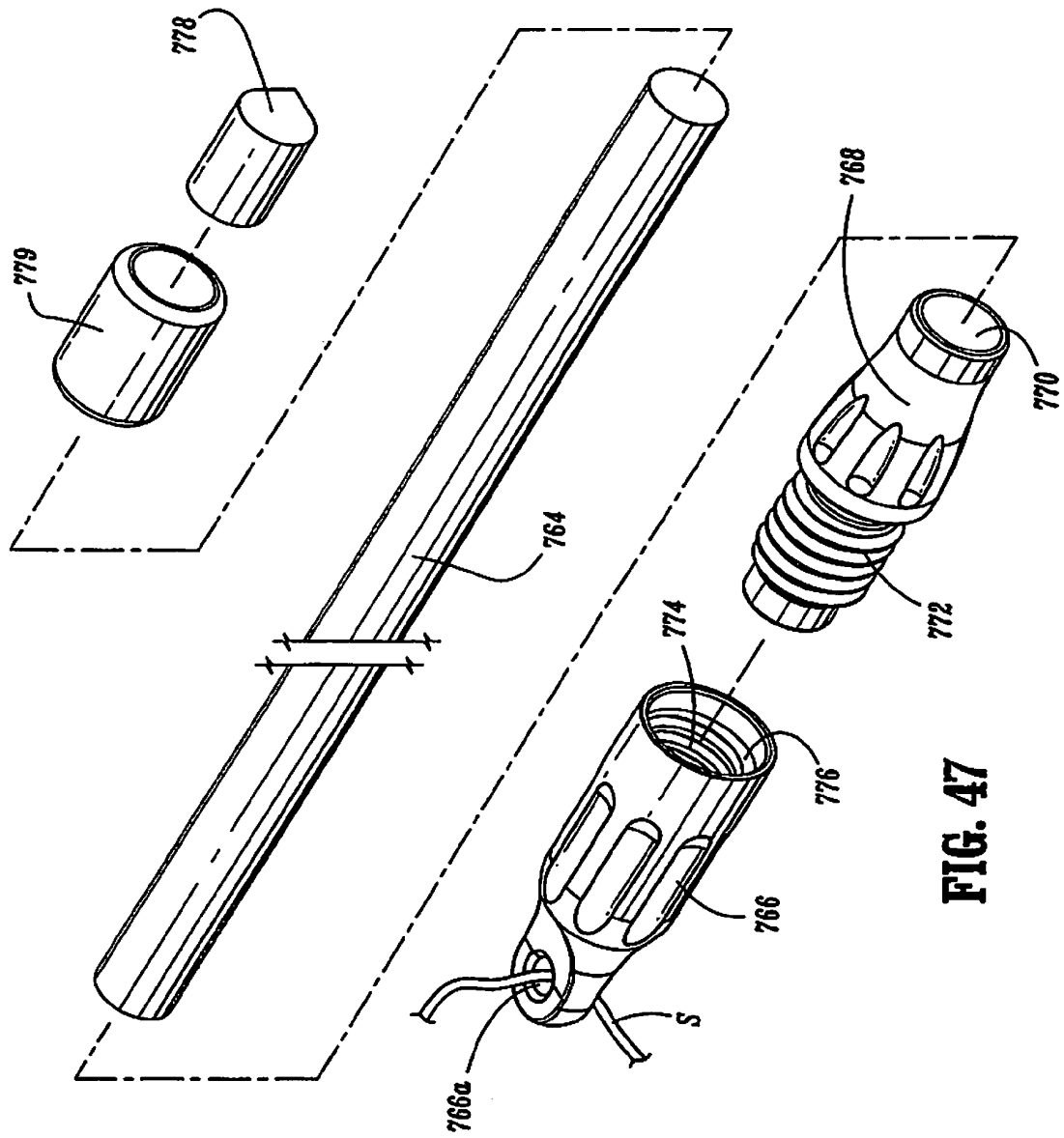

FIG. 47

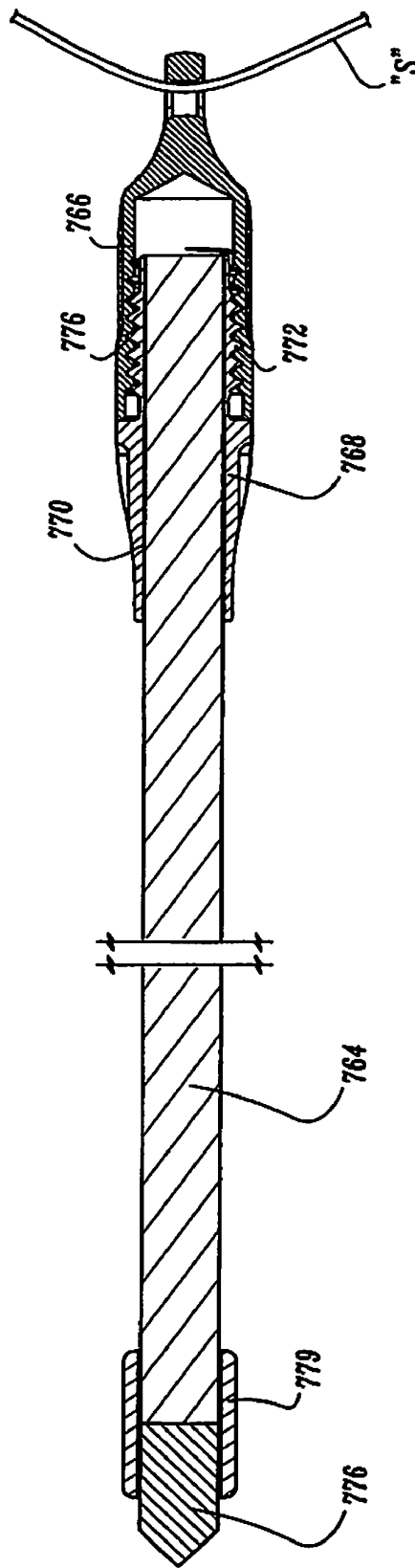

FIG. 48

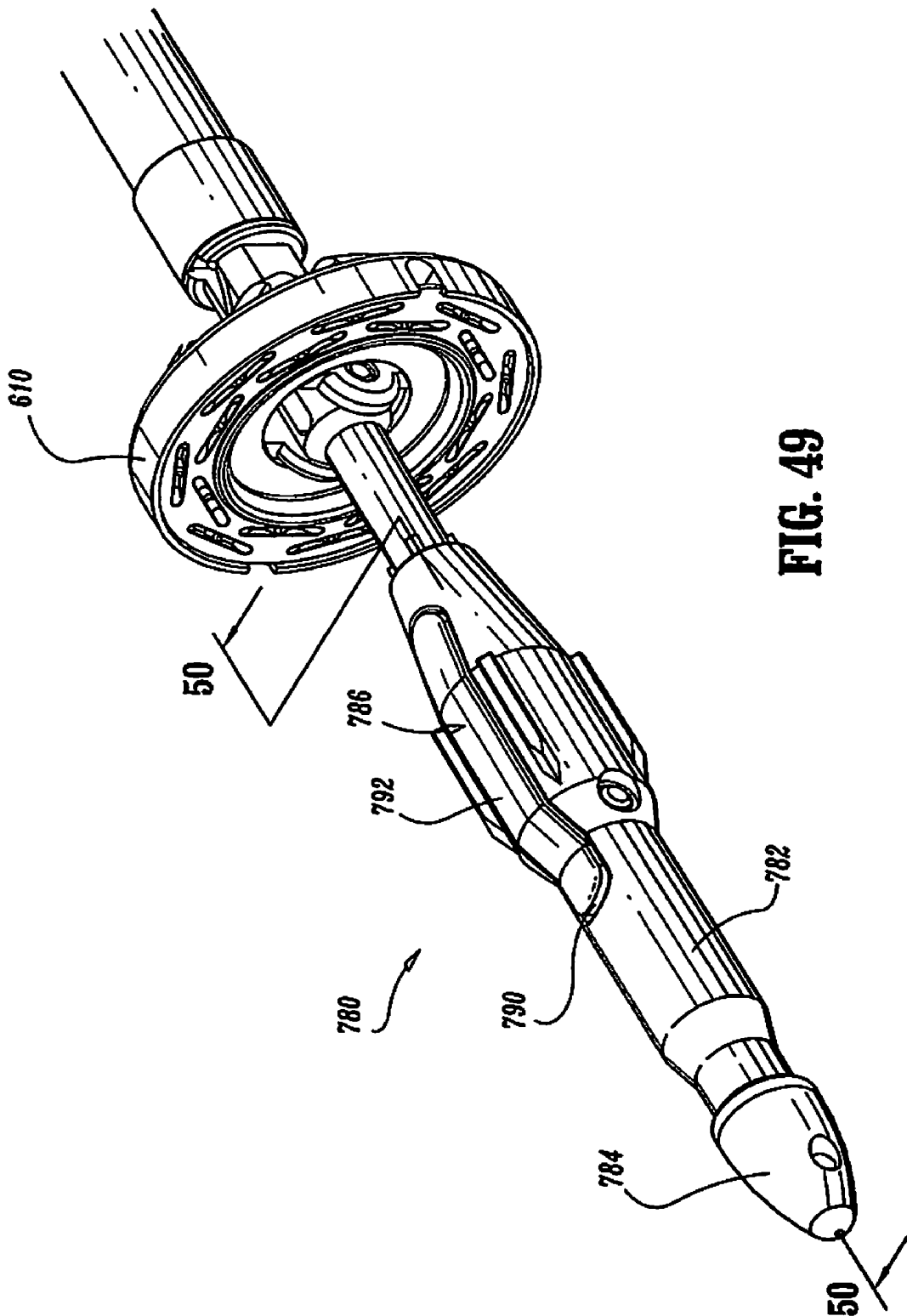

FIG. 49

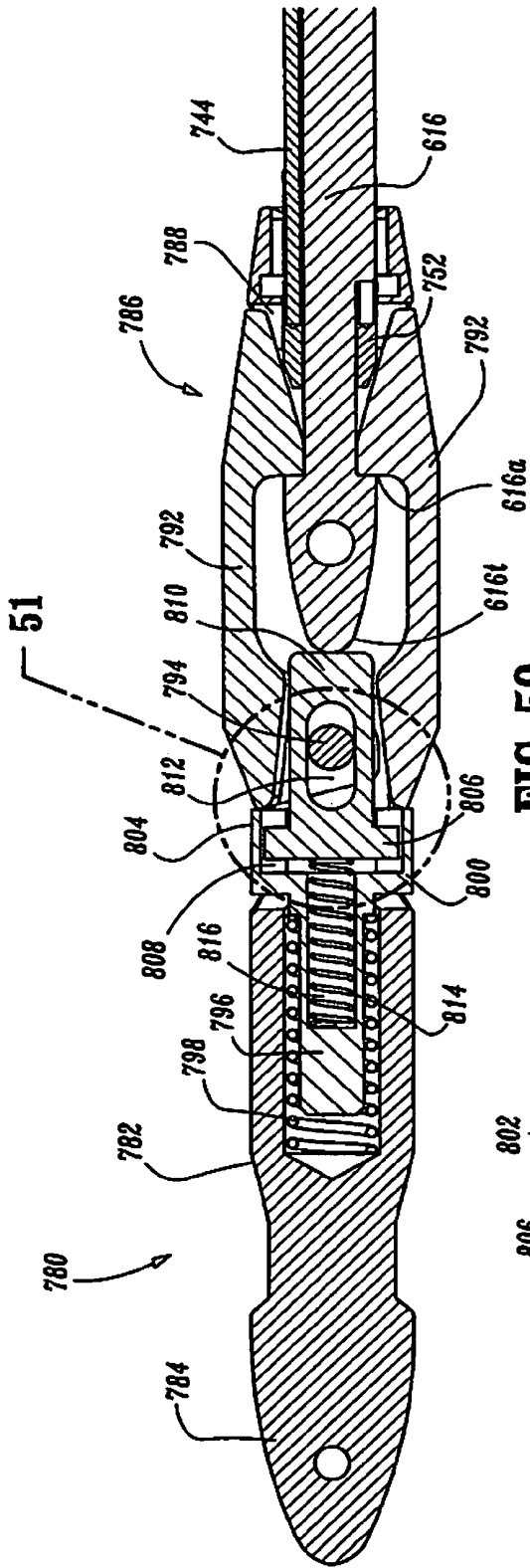

FIG. 50

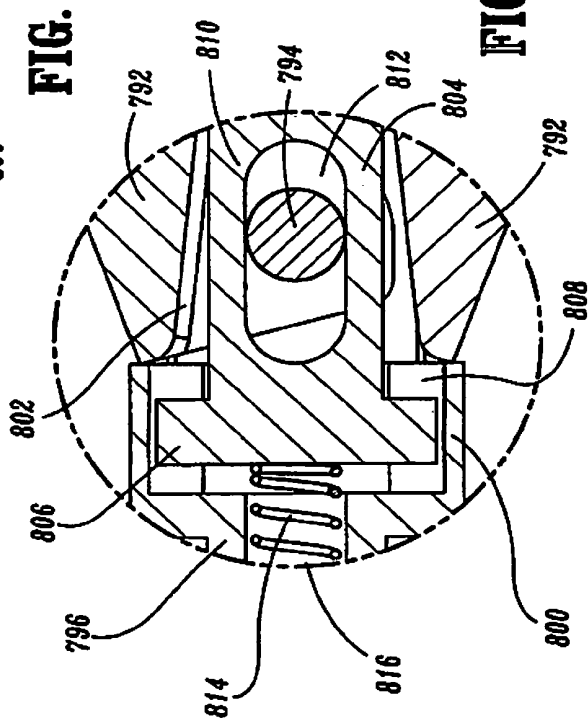

FIG. 51

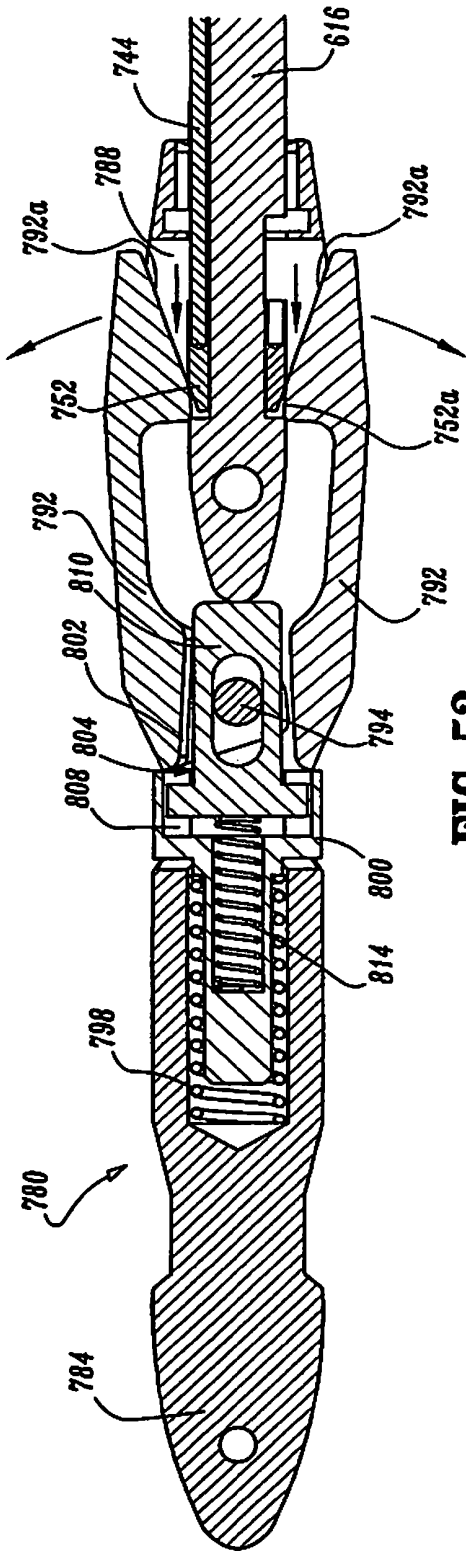

FIG. 52

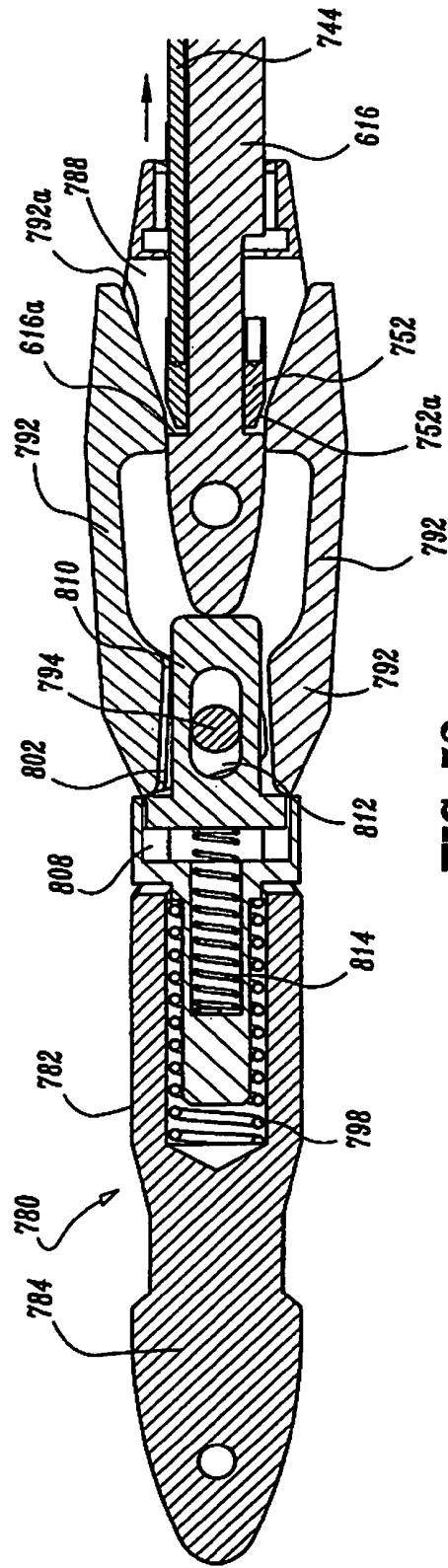

FIG. 53

FIG. 54

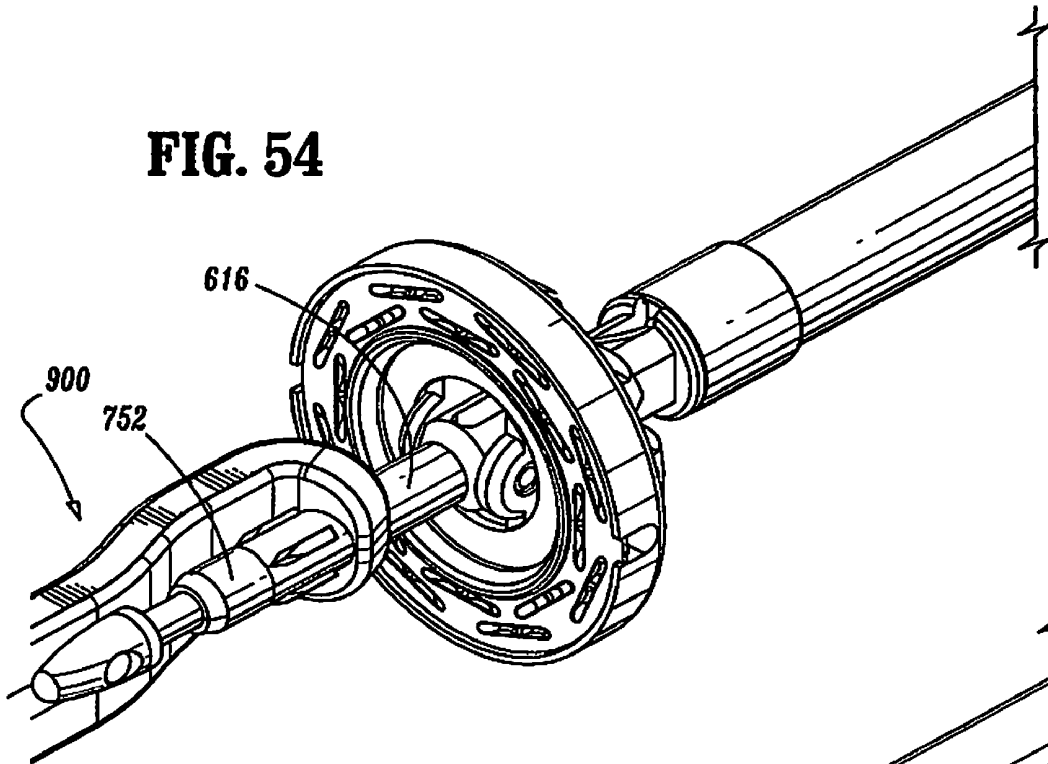
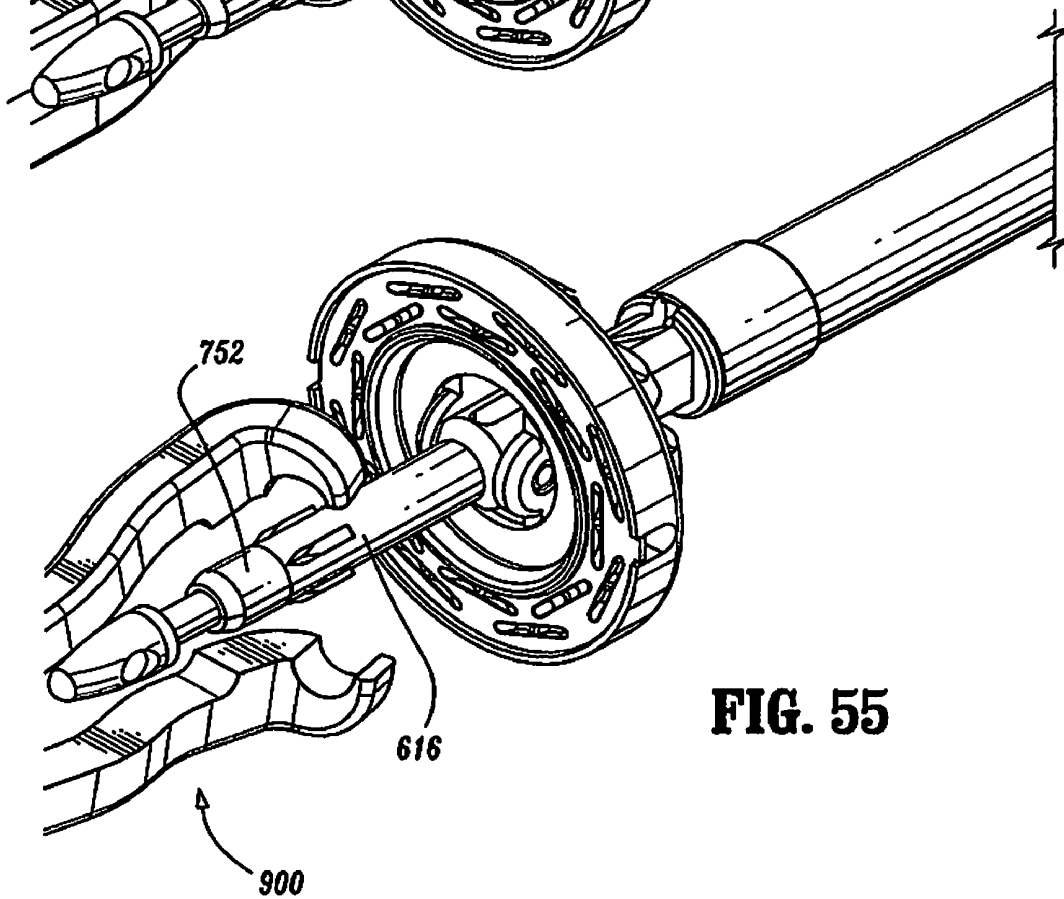

FIG. 55



**APPARATUS AND METHOD FOR
PERFORMING A BYPASS PROCEDURE IN A
DIGESTIVE SYSTEM**

CROSS-REFERENCE TO RELATED
APPLICATIONS

This application is a continuation of U.S. application Ser. No. 11/640,080, filed on Dec. 15, 2006, which is a divisional of U.S. application Ser. No. 10/234,086, filed on Aug. 30, 2002, now U.S. Pat. No. 7,179,267, which is a continuation of International Patent Application PCT/US2001/07105, filed on Mar. 5, 2001, which claims the benefit of and priority to U.S. Provisional Application Ser. No. 60/187,121, filed on Mar. 6, 2000. The entire contents of each of these applications are incorporated herein by reference.

BACKGROUND

1. Field of the Disclosure

The present disclosure relates generally to an apparatus and method for treating obesity, and, in particular, to an apparatus and method for performing a laparoscopic bypass procedure in a digestive system.

2. Description of the Related Art

Morbid obesity affects from about 3% to 5% of the population. The severely obese are at significantly greater risk of premature death, heart disease, stroke, diabetes mellitus, cancer, pulmonary diseases, orthopedic complications and accidents. The obese are also subject to discrimination in society, the workplace, etc.

Several methods for treatment of morbid obesity include diets, pills, and other weight-reducing plans. Mechanical devices for insertion into the stomach, e.g., gastric balloons, to at least partially occupy the stomach have also been utilized. These approaches, however, are generally effective for a limited period of time. In addition, over 95% of those participating in such approaches regain their original weight, and, in many instances, gain additional weight.

Methods for treating obesity proven effective over the long term include surgery to restrict the amount of food consumed at one sitting and to change the digestive process such that less of the food consumed will be absorbed into the body. These procedures are collectively known as Bariatric Surgery and include Gastroplasty, Gastric Banding and Gastric Bypass.

Gastroplasty incorporates separating the stomach into two pouch areas, e.g., an upper pouch and a lower pouch, through stapling. A small opening or stoma is then formed through the row of staples. Thus, the consumed food collects within the upper pouch and passes through the stoma and into the lower pouch at a reduced rate thereby giving a sensation of fullness to the individual to limit the amount of food intake. Disadvantages of this procedure include expansion of the upper pouch and the stoma which thereby minimizes long term effectiveness of this procedure.

In Vertical Banded Gastroplasty (VBG), an upper gastric pouch is formed within the stomach by applying a vertical row of staples. A band (e.g., a Marley mesh) is applied about the stomach adjacent the staple line to prevent dilation of the outlet port extending from the upper pouch into the remaining portion of the stomach. The Vertical Banded Gastroplasty (VBG) method, however, is subject to certain disadvantages including problematic post-operative healing, high rate of complications such as wound infection, pulmonary emboli, gastric perforation, gall bladder stones, etc.

Gastric Bypass combines the elements of intestinal rearrangement with a smaller stomach pouch. More particularly,

with this procedure, the stomach is divided into an upper pouch and a lower pouch. The upper pouch, which receives the consumed food, is greatly reduced in capacity and is directly connected to the small intestine. However, conventional gastric bypass techniques involve invasive surgical approaches which have a deleterious effect on patient recovery and down time.

In recent years, minimally invasive surgical techniques have been developed to reduce trauma to the patient and minimize recover time. Such minimally invasive procedures include endoscopy, laparoscopy, colonoscopy, etc. and typically require elongated narrow instruments to perform surgery on organs, tissues and vessels far removed from the incision. Laparoscopic procedures are performed in the interior of the abdomen through a small incision, e.g., through a tube or cannula inserted through a small entrance incision in the abdominal cavity. To date, however, satisfactory laparoscopic approaches and instrumentation for a bypass procedure in a digestive system have not been developed.

SUMMARY

Accordingly, the present disclosure is directed to surgical instrumentation and methods for performing a bypass procedure in a digestive system, which incorporates laparoscopic techniques to minimize surgical trauma to the patient. In one preferred embodiment, an apparatus for facilitating performance of a gastroplasty procedure, includes an outer guide member dimensioned for insertion and passage through an esophagus of a patient and defining an opening therein extending at least along a portion of the length of the outer guide member, an elongate anvil delivery member at least partially disposed within the opening of the outer guide member and being adapted for longitudinal movement within the outer guide member between an initial position and an actuated position and an anvil operatively engageable with the delivery member. The anvil includes an anvil rod defining a longitudinal axis and an anvil head connected to the anvil rod. The anvil head is at least partially, disposed within the opening of the outer guide member when in the initial position of the delivery member and is fully exposed from the distal end of the outer guide member upon movement of the delivery member to the actuated position.

The anvil head may be pivotally mounted to the anvil rod and movable between a non-operative position and an operative position. A pivot member at least partially disposed within the outer guide member and operatively connected to the anvil head moves between first and second positions thereof to cause corresponding movement of the anvil head between the respective non-operative and operative positions. The pivot member is normally biased to the second position thereof. Means for releasably locking the pivot member in the first position may be provided. Preferably, the pivot member includes a locking surface engageable with a corresponding locking surface of one of the delivery member and outer guide member to releasably lock the pivot member in the first operative position. Preferably, the pivot member includes a manually operable handle which defines the locking surface of the pivot element. The pivot member is preferably dimensioned to extend proximally beyond the insertion member to be grasped by the surgeon.

Alternatively, the anvil may be pivotally mounted to the delivery member. An elongate pivot member at least partially disposed within the outer guide member is operatively connected to the anvil and is movable to cause corresponding pivotal movement of the anvil through a pivotal range of motion.

A method for performing a bypass procedure in a digestive system is also disclosed. The method includes the steps of introducing an anvil through an esophagus of a patient and into a first digestive tissue portion, inserting an anastomosis instrument into a second digestive tissue portion displaced from the first digestive tissue portion, manipulating the anvil from a proximal location to position the anvil at a desired orientation with respect to the anastomosis instrument, connecting the anvil to the anastomosis instrument and firing the anastomosis instrument to connect the first and second digestive tissue portions.

In the alternative, a method for performing a bypass procedure in a digestive system includes the steps of isolating an upper stomach portion of the stomach of a patient, resecting the bowel to define a bowel portion disconnected from the stomach, and connecting the bowel portion and the upper stomach portion. The step of connecting is preferably performed with an end to end anastomosis instrument. The method may further include the step of introducing an anvil adapted for use with the anastomosis instrument through an esophagus and into the upper stomach portion and introducing an end to end anastomosis instrument into the bowel portion. The anvil and the end to end anastomosis instrument are connected, and the end to end anastomosis instrument is fired to connect the bowel portion and the upper stomach portion.

The step of isolating may include positioning a linear stapler instrument about the stomach and firing the linear stapler to isolate the upper stomach portion with respect to the remainder of the stomach. Similarly, the step of resecting includes positioning a linear stapler about the small bowel and firing the linear stapler. The linear stapler may have a knife blade associated therewith and wherein upon firing the knife blade is actuated to resect the bowel to define the bowel portion.

In an alternative, the method for performing a bypass procedure in a digestive system includes the steps of accessing digestive tissue portions of a digestive system, advancing an anvil through the esophagus and into the first digestive tissue portion, inserting an anastomosis instrument into the second digestive tissue portion, connecting the anvil with the anastomosis instrument and firing the anastomosis instrument to connect the first and second digestive tissue portions, disconnecting the anvil from the anastomosis instrument, and withdrawing the anvil through the esophagus.

The method may further include the step of manipulating the anvil from a proximal location outside the body to facilitate connecting of the anvil with the anastomosis instrument.

BRIEF DESCRIPTION OF THE DRAWINGS

Preferred embodiments of the disclosure are described herein with reference to the drawings wherein:

FIG. 1 is a perspective view of the apparatus for facilitating performance of a gastric bypass procedure in accordance with the principles of the present disclosure;

FIG. 2 is a perspective view with parts separated of the apparatus of FIG. 1, illustrating the insertion member and the anvil delivery member of the apparatus;

FIG. 3 is a perspective view with parts separated of the anvil delivery member;

FIG. 4 is a side cross-sectional view of the apparatus;

FIG. 5 is a perspective view of an end to end anastomosis instrument utilized to perform the gastric bypass procedure;

FIG. 6 is a perspective view of an endoscopic stapling instrument utilized to perform the gastric bypass procedure;

FIGS. 7-16 are views illustrating the sequence of steps in performing a laparoscopic gastric bypass procedure in accordance with one preferred method of the present disclosure;

FIG. 17 is a view of a portion of a digestive system with staple and resection lines in connection with alternate bypass procedures to be conducted in accordance with the present disclosure;

FIG. 18 is a perspective view of an alternate embodiment of the apparatus of FIG. 1;

FIG. 19 is a perspective view of the apparatus of FIG. 18 in an actuated position;

FIG. 20 is a perspective view of another alternate embodiment of the apparatus of FIG. 1;

FIG. 21 is a perspective view of the distal end of the apparatus of FIG. 20 illustrating the anvil in an inoperative position;

FIG. 22 is a perspective view of the distal end of the apparatus of FIG. 20 illustrating the anvil in an operative position;

FIG. 23 is a side plan view of an alternate embodiment of the apparatus of FIG. 1;

FIG. 24 is an axial view of the apparatus of FIG. 23;

FIG. 25 is a side cross-sectional view of the apparatus;

FIG. 26 is a side plan view of the distal end of the apparatus illustrating the anvil in an inoperative position;

FIG. 27 is a view similar to the view of FIG. 26 illustrating the anvil in an operative position;

FIG. 28 is a side cross-sectional view of the distal end of the apparatus;

FIG. 29 is a perspective view of an alternate embodiment of the apparatus of the present disclosure illustrating the catheter guide, delivery apparatus, and mounted anvil assembly;

FIG. 30 is an enlarged perspective view of the anvil assembly mounted to the catheter guide and delivery apparatus;

FIG. 31 is a perspective view illustrating connection of a suture unit of the anvil assembly to the catheter guide;

FIGS. 32A-32B are side plan and cross-sectional views of the anvil rod of the anvil assembly;

FIGS. 33A-33B are cross-sectional and side plan views of the anvil adapter;

FIG. 34 is a perspective view illustrating mounting of the anvil rod to the anvil adapter;

FIG. 35 is a cross-sectional view of the anvil assembly and mounted anvil adapter;

FIGS. 36-39 are views illustrating the sequence of steps in performing the laparoscopic gastric bypass procedure with the instruments of FIG. 29;

FIG. 40 is a perspective view of another alternate embodiment of the present disclosure illustrating the delivery apparatus and mounted anvil assembly;

FIG. 41 is a perspective view with parts separated of the apparatus of FIG. 40;

FIG. 42 is a side cross-sectional view of the apparatus in an initial position;

FIG. 43 is a view similar to the view of FIG. 42 illustrating the pivot mechanism actuated corresponding to the pivoted position of the anvil head;

FIG. 44 is a view similar to the view of FIG. 42 illustrating the release mechanism actuated to release the anvil from the anastomosis instrument;

FIGS. 45-46 are perspective views of the light guide which is attachable to the anvil assembly;

FIG. 47 is a perspective view with parts separated of the light guide;

FIG. 48 is a side cross-sectional view of the light guide;

FIG. 49 is a perspective view of an anvil adapter depicted mounted to an anvil assembly;

FIG. 50 is a cross-sectional view of the anvil adapter taken along the lines 50-50 of FIG. 49;

FIG. 51 is an enlarged isolated view depicting the relationship of the plunger and jaw mechanism of the anvil adapter;

FIGS. 52-53 are cross-sectional views of the anvil adapter illustrating activation of the release mechanism to release the anvil adapter from the anvil assembly; and

FIGS. 54-55 are enlarged perspective views of the jaw assembly of a grasping instrument suitable for grasping the anvil rod.

DETAILED DESCRIPTION OF PREFERRED EMBODIMENTS

The preferred embodiments of the method and instrumentation disclosed herein are discussed in terms of bypass procedures in the digestive system, and instrumentation utilized to carry-out the procedures. Although described specifically in connection with a laparoscopic approach, it is envisioned that the disclosure is applicable to a conventional open approach as well.

The following discussion will include a description of each instrument utilized in performing a digestive system bypass procedure followed by a description of preferred methods for bypass utilizing the instrumentation in accordance with the present disclosure.

In the discussion which follows, the term "proximal", as is traditional, will refer to the portion of the structure which is closest to the operator, while the term "distal" will refer to the portion which is furthest from the operator.

Referring now to FIGS. 1-4, there is illustrated one preferred embodiment of the apparatus for performing a laparoscopic digestive bypass procedure in accordance with the principles of the present disclosure. Apparatus 10 includes generally two components, namely, outer guide member 12 and anvil delivery member 14 which is at least partially disposed within the outer guide member 12. Guide member 12 is fabricated from a flexible material such that the guide member 12 may bend or flex as required during deployment of the anvil delivery member 14. In a preferred embodiment, guide member 12 comprises an elastomeric material. As best depicted in FIG. 4, guide member 12 includes an internal opening or cavity 16 which accommodates at least a portion of delivery member 14. Guide member 12 defines longitudinal axis "a" and has proximal end portion 18, distal end portion 20 and intermediate portion 22 disposed between the proximal and distal end portions 18, 20. Intermediate portion 22 defines an internal dimension 22a which is larger than both the respective internal dimensions 18a, 20a of the proximal end portion 18 and the distal end portion 20. Intermediate portion 22 also includes an internal groove 24 defined therein (FIG. 4). Preferably, each of the proximal and distal end portions 18, 20 of guide member 12 gradually taper in linear relation to intermediate portion 22 as shown. Distal end portion 20 of guide member 12 further defines an axial opening 26. Slits 28 permit the guide member 12 to flare outwardly to enlarge the effective size of opening 26.

With particular reference to FIGS. 2-4, anvil delivery member 14 includes elongated support member 30 and anvil 32 which is supported at the distal end portion of the support member 30. Support member 30 includes elongate member 34, pivot block support 36 mounted to the elongate member 34 by pin 38 and pivot block 40 which is connected to the pivot block support 36 by pin 42. Although shown as several components, it is appreciated that support member 30 can be manufactured as a monolithic unit as well. Elongate member 34 is preferably sufficient in length and relatively flexible to

extend from the stomach through the esophagus of the patient and out the oral cavity to be grasped by the surgeon.

Anvil 32 is intended for use with a circular or end-to-end anastomosis instrument as will be discussed. Anvil 32 includes anvil head 44 and anvil rod 46 extending from the anvil head 44. Generally, anvil head 44 includes a plurality of recesses which are adapted to form and close staples ejected from the circular anastomosis instrument. Anvil rod 46 engages corresponding mounting structure of the circular anastomosis instrument to mount anvil 32 to the instrument. Anvil 32 further includes pivot head 48 which pivotally connects to pivot block 40 through pin 50 to permit the anvil 32 to pivot through at least a predetermined range of pivotal motion. In a preferred embodiment, anvil 32 is pivotable through a 90° range of motion in one direction relative to the longitudinal axis with the range of motion being restricted by engagement of shelf 52 of pivot head 48 and pivot block 40 (see FIG. 4). One anvil suitable for the purposes of the present disclosure is disclosed in commonly assigned U.S. Pat. No. 5,718,360 to Green et al., the contents of which are incorporated herein by reference.

As best depicted in FIGS. 3-4, anvil delivery member 14 further includes pivot rod 54 which extends through guide member 12 and engages anvil head 44 of anvil 32 as shown. In a preferred arrangement, pivot rod 54 includes a hooked portion 56 which engages a corresponding dimensioned receiving groove 58 disposed within anvil head 44. Other means for connecting anvil head 44 and pivot rod 54 are envisioned as well. Pivot rod 54 is sufficient in length to extend from the stomach through the esophagus to be manipulated by the surgeon. Pivot rod 54 is longitudinally moveable between a retracted position and an extended position to selectively pivot anvil 32 at desired orientations.

In the assembled condition of anvil delivery member 14 within guide member 12, the outer margin of anvil head 44 is received within internal groove 24 of the guide member 12 to retain anvil 32 at the desired position mounted within the guide member 32. It is appreciated that groove 24 may be eliminated whereby anvil 32 may be fixed within guide member 12 by frictional engagement of anvil head 44 with the inner wall surface of the guide member 12.

Referring now to FIGS. 5-6, there is illustrated additional instrumentation utilized to perform the method in accordance with the principles of the present disclosure. FIG. 5 illustrates a circular or end to end anastomosis instrument. This instrument 100 is marketed under the name PREMIUM CEEA™ manufactured by U.S. Surgical Corporation, of Norwalk, Conn. and is the subject of commonly assigned U.S. Pat. No. 5,119,983, the contents of which are incorporated herein by reference. This instrument 100 includes an elongated shaft 102 having a handle portion 104 at a proximal end to actuate the instrument and a staple holding component 106 disposed at a distal end. An anvil component such as anvil 32 described above is mountable to the distal end. Opposed end portions of the organs to be stapled are clamped between the anvil head 44 and the staple holding component 106. The clamped tissue is stapled by driving one or more staples from the staple holding component 106 so that the ends of the staples pass through the tissue and are clinched by the anvil head 44. In some applications of the circular anastomosis procedure, the anvil rod 46 with attached anvil head 44 is mounted to the distal end of the shaft 102 prior to insertion of the instrument into the tissue to be anastomosed. However, in other applications and in accordance with the preferred method of the present disclosure, it is preferable to utilize a detachable anvil 32 which may be mounted to the instrument subsequent to positioning of the instrument and the anvil component within

their respective tissue sections. In such instances, the stapling instrument and the anvil **32** are separately applied to the operative site. Each tissue section is then secured to their respective anvil **32** or staple holding component **106** by a purse string. The anvil **32** is mounted to the surgical instrument by inserting anvil rod **46** of the anvil **32** within the distal end of the instrument so that a mounting mechanism within the instrument securely engages the rod **46**.

FIG. **6** illustrates an endoscopic linear surgical stapling apparatus marketed under the name ENDO GIA™ manufactured by U.S. Surgical Corporation of Norwalk, Conn. and is the subject of commonly assigned U.S. Pat. No. 5,894,979, the contents of which are incorporated herein by reference. This instrument **200** is adapted to place a plurality of longitudinal or linear rows of staples and may further include a knife for making an incision in body tissue between the rows of staples. The instrument **200** includes a frame **202** and an elongated tubular member **204** mounted to the frame **202**. Mounted to the distal end portion of the tubular member is a cartridge assembly **206** which houses a plurality of rows of staples. An anvil **208** is pivotably movable relative to the cartridge assembly **206** to position tissue therebetween. Upon activation, the staples are fired to be clinched by the anvil **208** while the knife severs the tissue between the adjacent rows of staples.

In FIGS. **7-16**, the disclosure describes methods for performing a bypass procedure in a digestive system that is representative of accessing, preferably, laparoscopically, and connecting a first and a second digestive system tissue portion. The digestive system or tract as defined herein includes the mouth, pharynx, esophagus, stomach, duodenum and colon.

Referring now to FIGS. **7-16**, by way of example, there is illustrated the preferred method for performing the laparoscopic gastric bypass procedure utilizing the aforescribed instrumentation in accordance with the principles of the present disclosure. Initially, the peritoneal cavity is insufflated with insufflation gases which are introduced through a peritoneum needle of an insufflation apparatus, thus, distending the peritoneal lining and providing enhanced access therein. With reference now to FIG. **7**, endoscopic linear stapling instrument **200** of FIG. **6** is introduced through a trocar "t" accessing the abdominal cavity. The instrument **200** is manipulated to position an upper portion of the stomach between the anvil **208** and the cartridge assembly **206**. The instrument **200** is fired a first time whereby a first plurality of linear rows of staples are applied to the stomach portion at one angular orientation and then fired a second time at a second angular orientation to apply a second row of staples. As depicted in FIGS. **7-8**, stapling instrument **200** preferably is arranged with respect to the esophageal tract to form a staple line S_1 which extends generally upwardly from the right side of the stomach to the left side (left to right with respect to the drawing). A knife blade incorporated within the instrument **200** removes or severs the tissue between adjacent rows of the staple line S_1 . Thus, instrument **200** applied in the above-described manner forms an isolated upper stomach section "u" detached from the remaining lower section "l" of the stomach with both the upper and lower stomach sections "u, l" being closed by respective stapled rows S_{1a} and S_{1b} (FIG. **8**). Alternatively, it is envisioned that the upper stomach section "u" may remain attached to the remaining stomach portion by use of stapling instrument **200** which is devoid of a knife blade.

With reference again to FIG. **7**, the linear stapling instrument **200** is then positioned adjacent the small bowel through a trocar "t" in the lower part of the abdomen. Preferably, the

instrument **200** is positioned adjacent an intermediate portion of the small bowel approximately 5-15 inches from the duodenum "d". The instrument **200** is fired to apply staples to form a staple line S_2 and preferably incise the bowel portion to thereby form a first bowel portion "b₁" connected to the stomach and a second bowel portion "b₂" which is connected to the remainder of the intestinal tract. The ends of the first and second bowel portions "b₁", "b₂" are closed with respective linear rows of staples S_{2a} and S_{2b} (FIG. **8**).

Referring particularly to FIG. **8**, apparatus **10** is inserted within the esophagus "e" of the patient and advanced in the direction "A" within the now formed upper stomach portion "u". The small bowel portion "b₂" is manipulated towards the upper stomach section "u". Preferably, a conventional grasping instrument introduced through trocar sleeve "t" accessing the stomach is utilized to manipulate the bowel portion "b₂" to the desired position. The circular anastomosis instrument **100** (FIG. **5**) is inserted through the trocar "t" positioned adjacent the upper stomach portion "u" and positioned within a previously formed opening "o" in the bowel portion "b₂" made preferably with a conventional laparoscopic resecting instrument inserted within the trocar. The distal end of the circular anastomosis instrument **100** is thereafter advanced within the opening "o" such that the staple holding component **106** is disposed within the lumen of the bowel portion "b₂".

With reference now to FIGS. **9-10**, anvil **32** is manipulated and then pivoted by advancing pivot rod **54** from the position shown in FIG. **9** to the position shown in FIG. **10**, as desired, to position anvil rod **46** at a desired orientation for connection to instrument **100**. As indicated above, anvil **32** is pivotal through an approximately 90° range of motion while guide member **12** is sufficiently flexible to permit such pivotal movement. As appreciated, guide member **12** protects the interior of the stomach from the anvil during pivotal movement of anvil **32** relative to the support member **30**.

With reference now to FIGS. **11-12**, support member **30** of instrument **10** is longitudinally advanced to advance anvil **32** within guide member **12** to expose the end portion of anvil rod **46** of anvil **32** from the guide member **12**. During such movement, slits **28** in the outer wall of guide member **12** (FIG. **2**) permit the outer wall to deflect outwardly to enable anvil rod **46** to pass through opening **26**. Thereafter, anvil rod **46** can be grasped with conventional forceps inserted through a trocar accessing the cavity and advanced through an opening "o₂" formed by conventional means in the upper stomach portion "u" to the position shown in FIG. **12**. The forceps may be introduced through the opening "o" (FIG. **8**) created in the bowel portion "b₁" and maneuvered to grasp anvil rod **46** and pull the anvil rod **46** through the opening. In accordance with this procedure, the staple holding component **106** of the instrument **100** is introduced within the opening "o" after accessing anvil rod **46** of anvil rod **32**. It is also envisioned that anvil rod **46** may include a sharpened tip which is manipulated to pierce the stomach tissue to connect to the circular anastomosis instrument **100**. Alternatively, the sharpened anvil rod **46** may be passed through the staple lines S_{1a} , S_{2b} .

With reference now to FIGS. **13-14**, anvil rod **46** is grasped with conventional forceps inserted through a trocar (not shown) and positioned such that anvil rod **46** is adjacent the circular anastomosis instrument **100**. Thereafter, anvil rod **46** is inserted within the circular anastomosis instrument **100** to be mechanically coupled therewith. Anvil rod **46** is thereafter approximated as is conventional and the instrument is fired. As a result of the firing of the instrument **100**, a circular array of staples are advanced through the bowel section "b₂" and upper stomach tissue to join the marginal tissue portions of

the upper portion "u" and the small bowel portion "b₂". In addition, a circular knife of the anastomosis instrument **100** defines an annular opening between the tissue sections to fluidly connect the interior of the upper stomach portion "u" and the lumen of the bowel portion "b₂". Thereafter, the anvil **34** is detached from the circular anastomosis instrument **100** and the delivery instrument with attached anvil **32** is removed through the esophagus "e", i.e., in the direction "B" opposite to the insertion direction "A" shown in FIG. **8**.

With reference now to FIG. **15**, attention is now directed to rejoining the bowel sections "b₁", "b₂". In one preferred method, bowel sections "b₁", "b₂" are positioned in juxtaposed side by side relation and joined with the use of the linear stapler instrument **200** of FIG. **6**. Specifically, the instrument **200** is introduced within a trocar "t" accessing the abdominal area. Thereafter, cartridge assembly **206** is introduced within the end of bowel section "b₁" through the staple line S_{2a}. An opening "o" is made in the wall of bowel section "b₂" followed by insertion of anvil **208** within the opening "o" and into the lumen of bowel section "b₂". The instrument **200** is approximated and fired to connect the bowel sections "b₁", "b₂" with rows of staples whereby the knife blade severs tissue between adjacent staple rows to connect the lumens of the bowel sections "b₁", "b₂". The instrument **200** is removed and the opening in the wall of the bowel section "b₂" is closed.

In an alternate procedure depicted in FIG. **16**, the circular anastomosis instrument **100** of FIG. **5** is positioned through a trocar "t" accessing the abdominal cavity. The closed stapled end "S_{2a}" of bowel section "b₁" is positioned against the wall of bowel section "b₂". Thereafter, an access opening "o" is formed in one of the bowel sections, e.g., bowel section "b₁", and the staple holding component **106** with mounted anvil **32** is introduced within the opening "o". The instrument **100** is advanced to pass the anvil head **44** through an opening formed (by conventional techniques) in the bowel section "b₂" to position the anvil head **44** within the lumen of the bowel section "b₂". Anvil head **44** is thereafter approximated and the instrument **100** is fired to join the marginal tissue portions of bowel sections "b₁", "b₂" while the circular knife of the instrument **100** resects the tissue to connect the respective lumens of the sections "b₁", "b₂".

Thus, in accordance with the apparatus and method of the present disclosure, the stomach is reduced significantly in size while the normal digestive path of the intestinal tract is maintained thereby providing an effective treatment for obesity. The preferred surgical approach is minimally invasive which significantly reduces patient trauma and recovery time.

Referring now to FIG. **17**, alternate bypass procedures to be performed in the digestive system in accordance with the instrumentation and method of the present invention are illustrated. In addition to the aforementioned gastric bypass procedure connecting the upper stomach section "u" adjacent staple line S₁ with the small bowel adjacent staple line S₂, described in connection with FIGS. **7-16**, other preferred bypass procedures are envisioned. For example, it is envisioned that a portion of the esophagus and stomach may be resected adjacent staple lines S₄, S₅, respectively and subsequently rejoined adjacent the staple lines S₄, S₅ in a bypass procedure. More specifically, a staple line S₅ is formed within the intermediate stomach section in the manner as discussed above in connection with FIGS. **7-15**. Another staple line S₄ is formed at the lower end of the esophagus. This staple line S₄ may be created through a trocar and with the stapling instrument **200** of FIG. **6** in a manner similar to that described above. The resected esophageal and stomach tissue (i.e., between the staple lines S₄, S₅) is removed. Apparatus **10** is introduced into the esophagus and the anvil **32** is deployed

and manipulated through an opening (not shown) adjacent staple line S₅. The circular anastomosis instrument **100** is then introduced into the stomach portion below staple line S₅ followed by connection of the anastomosis instrument **100** and the anvil **32** as discussed above. The tissue is approximated and the instrument is fired to connect the esophageal section adjacent staple line S₄ with the stomach section adjacent staple line S₅. Anvil **32** is then disconnected from anastomosis instrument **100** and removed, thereby completing the procedure.

One skilled in the art may readily adapt the preferred method of performing additional bypass procedures in the digestive system which includes, but is not limited to connecting a stomach section defined by staple lines S₁ or S₅ to an intestinal section defined by staple lines S₂ or S₆; connecting an esophageal section defined by staple lines S₃ or S₄ to a stomach section defined along staple lines S₁ or S₅; connecting an esophageal section along staple lines S₃ or S₄ to an intestinal section defined along staple lines S₂ or S₆; or connecting stomach sections along staple lines S₁, S₅. While staple lines S₁-S₆ are shown as precise lines, it is understood that their positions in FIG. **16** are representative, for the purposes of illustrating the bypass procedure in a digestive system, and are capable of being modified within that procedure for each individual application by one skilled in the art. Similarly, the anastomosis instrument **100**, endoscopic linear stapling instrument **200**, and anvil **32** are representative instruments that can be substituted for by one or more similar devices that perform similar functions.

Referring now to FIGS. **18-19**, there is illustrated an alternate embodiment of the apparatus **10** of FIGS. **1-4**, for delivering an anvil in conjunction with the laparoscopic digestive bypass procedure of the present disclosure. Apparatus **300** includes an outer sheath **302**, anvil delivery member **304** disposed within the outer sheath **302** and an anvil component **306** mounted within the outer sheath **302**. Delivery member **304** includes proximal disc-shaped handle **308** which is advanced to move anvil component **306** between an initial position (FIG. **18**) disposed within outer sheath **302**, and an advanced position (FIG. **19**) where the anvil **306** is fully ejected from the outer sheath **302**. Apparatus **300** further includes a bull-nosed shaped cap **310** which is mounted to the proximal end of anvil rod **312** to cover the anvil rod **312** during passage through the esophagus. Cap **310** is preferably fabricated from a bioabsorbable polymer such that subsequent to deployment of anvil component **306** from outer sheath **302**, the cap **310** may be removed from anvil rod **312** to be left for absorption into the body.

Referring now to FIGS. **20-22**, there is illustrated another alternate embodiment of the apparatus **10** of FIG. **1**. In accordance with this embodiment, apparatus **400** includes an anvil component **402** which is pivotally mounted to delivery member **404** through pivot connection **406** thereby providing a pivotal range of motion of approximately 180°. In addition, anvil head **408** of anvil component **402** is pivotally mounted to anvil rod **410** through pivot pin **412** and thus pivots relative to anvil rod **410** through a 180° range of motion. This facilitates positioning of anvil component **402** relative to the end to end anastomosis instrument **100**. In addition, this arrangement significantly reduces the overall profile of anvil component **402** from the outer sheath (not shown) and passage through the esophageal tract. In particular, when positioned in the outer sheath (not shown), anvil head **408** is in the arrangement of FIG. **21** pivoted in a non-operative position, i.e., ninety degrees (90°), with respect to the axis of anvil rod **410**. Subject to deployment in the desired digestive tissue, e.g., the

upper stomach section “u”, anvil component **402** is mounted to the anastomosis instrument **100** of FIG. **5** in the afore-described manner. Thereafter, anvil head **408** is pivoted to the proper operative orientation (FIG. **22**) with respect to the staple holding component **106** of the circular anastomosis instrument **100** by pulling delivery member **404** in the proximal direction.

Referring now to FIGS. **23-28**, there is illustrated another alternate embodiment of the apparatus for performing a laparoscopic gastric bypass procedure in accordance with the principles of the present disclosure. Apparatus **500** may include outer sheath or guide member (not shown) which may be similar to the configuration of the outer guide **12** of the apparatus **10** of FIG. **1** or the configuration of the outer sheath **302** of the apparatus of FIG. **18**. Alternatively, and in the preferred embodiment, no outer sheath is incorporated in apparatus **500**. Apparatus **500** further includes delivery member **502** defining longitudinal opening **504**, pivot element **506** at least partially disposed within the longitudinal opening **504** and anvil component **508** connected to the delivery member **502**. Delivery member **502** defines disc-shaped handle **510** at its proximal end which is advantageously dimensioned for engagement by the user. Delivery member **502** and pivot element **506** are preferably sufficient in length to extend from the upper stomach section through the esophageal tract and out the mouth or oral cavity.

Pivot element **506** includes manually engageable portion or button **512** at its proximal end and pivot link **514** which is connected to the button **512** and extends distally therefrom. Pivot link **514** is connected to the anvil head **516** of anvil component **508** through pin **518**. In the preferred embodiment, **506** pivot element includes proximal and distal link portions **506a**, **506b** connected to each other through pin **520**, however, it is envisioned that pivot element **506** may be a single component.

Pivot element **506** is adapted for reciprocal longitudinal movement within delivery member **502** between an initial position (FIG. **25**) and an actuated (or retracted) position to cause corresponding pivotal movement of the anvil head **516** of the anvil component **508**. Pivot element **506** is normally biased to the actuated position by coil spring **522**. Coil spring **522** is mounted within the interior of disc-shaped handle **510** and engages at one end, interior wall surface **524** of the handle **510** and, at its other end, abutment surface **526** of button **512**. Pivot element **506** is releasably locked in its initial position against the bias of coil spring **522** by a locking mechanism. In the preferred embodiment, a locking ring **528** is mounted within a circumferential recess **530** at the proximal end of handle **510** of delivery member **502**. Locking ring **528** defines an internal locking shelf **532**. Similarly, button **512** of pivot element **506** includes a corresponding locking shelf **534** which engages the shelf **532** of locking ring **528** to releasably lock the pivot element **506** in the initial position. To release button **512**, the button **512** is moved away from locking shelf in a radial direction, i.e., toward the left with respect to FIG. **24**. It is noted that a sufficient clearance exists between the outer surface **536** of button **512** and the interior surface of locking ring **528** to permit such radial movement of the button **512**. Once released, pivot element **506** moves rearwardly under the influence of coil spring **522** to cause the pivotal anvil head **516** of anvil component **508** to pivot to the operative position of FIG. **27**.

With reference to FIG. **28**, in conjunction with FIGS. **23-27**, further details of anvil component **508** will be discussed. Anvil component **508** includes anvil rod **538** and the anvil head **516** pivotally mounted to the anvil rod **538** through pivot pin **540**. Anvil head **516** is arranged in oblique relation

relative to the axis of the delivery member **502** when in the initial position of the pivot element **506**. Such arrangement significantly reduces the overall profile of anvil component **508**, thereby reducing the overall diameter requirement of the outer sheath. This significantly facilitates passage of the apparatus through the restricted lumen of the esophageal tract.

Anvil component **508** has an adapter assembly **542** mounted to the end of the anvil rod **538** opposite anvil head **516**. Adapter assembly **542** includes an adapter rod **544** defining a longitudinal opening **546** at one end to receive anvil rod **538** of anvil component **508**. Preferably, the longitudinal opening **546** of adapter assembly **542** is correspondingly dimensioned such that the assembly **542** forms a snap-fit about the entrance end of anvil rod **538** to mount the anvil rod **538** to the adapter assembly **542**. Adapter assembly **542** is preferably connected to the anastomosis instrument **100** (FIG. **5**) and then is subsequently connected to anvil component **508** after the instruments have been introduced into the surgical site, i.e., adapter assembly **542** is not connected to anvil component **508** prior to introduction of the instrument **500** into the esophagus. It is noted that in FIGS. **23-28** adapter **542** is shown mounted to anvil rod **538** for illustrative purposes. Alternatively, the anvil adapter **542** may be first attached to anvil rod **538** after introduction into the surgical site and then connected to the anastomosis instrument **100**. The use of adapter assembly **542** permits anvil rod **538** to be significantly reduced in size and diameter, thereby facilitating passage of the instrument **500** and anvil component **508** through the esophagus, and manipulation about the surgical site. Further details of the adapter assembly will be discussed in connection with the embodiment of FIG. **29**.

In use, in connection with the method of FIGS. **7-16**, apparatus **500** with mounted anvil component **508** is introduced through the esophageal tract and advanced within the upper stomach section “u” (FIG. **8**). Circular anastomosis instrument **100** with mounted adapter assembly **542** is introduced within bowel section “b₂” (FIG. **8**). Anvil rod **538** is then connected to anvil adapter **542** in the aforedescribed manner. Alternatively, anvil adapter **542** is first connected to anvil rod **538** followed by connection of the anvil adapter **542** to the circular anastomosis instrument **100**. Button **512** of instrument **500** is then released to permit pivoting element **506** to move proximally under the bias of coil spring **522**. Upon proximal movement of pivot element **506**, anvil head **516** pivots to its operative position (FIG. **27**) whereby the anvil surface is transverse to anvil rod **538**. Anvil component **508** and staple holding component **106** of instrument **100** are approximated and the instrument is fired to connect the tissue sections “b₁”, “b₂”. Upon completion, anvil rod **538** is disconnected from adapter assembly **542** and apparatus **100** with mounted anvil component **508** is removed through the esophageal tract. Prior to removal, anvil head **516** is preferably pivoted and locked in its non-operative position by depressing button **512**.

Referring now to FIG. **29**, there is illustrated another alternate embodiment of the present disclosure. System **600** includes delivery instrument **602**, anvil component **604** and catheter guide **606** which is releasably connected to the anvil component **604**. Delivery apparatus **602** is substantially similar to the apparatus **500** described in connection with FIGS. **23-28**, and reference is made thereto for the particulars of its operating mechanisms. Anvil component **604** is also similar to the anvil component **508** of FIGS. **23-28**. However, in accordance with this embodiment and as best depicted in FIG. **30**, anvil component **604** further includes suture unit **608**. Suture unit **608** functions in connecting delivery instrument

102 with catheter guide 606. A suture 612 is passed through aperture 614 of anvil rod 616, through opening 618 in a depending surface of anvil head 610, and back through the aperture 614 of the anvil rod 616 in a race track arrangement. As depicted in FIGS. 30-31, the free ends of the suture 610 are connected by conventional means to an externally threaded collar 622 which is subsequently connected to catheter guide 606 as will be discussed. The suture 610 is sufficiently taut upon assembly so as to facilitate retention of the anvil head 610 in the pivoted non-operative position.

With reference to FIGS. 32A and 32B, anvil rod 616 is specifically adapted for non-invasive transport through the restricted esophageal passageway. More particularly, anvil rod 616 is substantially reduced in length and in cross-sectional dimension as compared to conventional anvil rods used with circular anastomosis instruments. The length "l" of anvil rod 616 ranges from about 1.50 inches to about 1.90 inches, and the maximum diameter "d" ranges from about 0.17 inches to about 0.21 inches. In the preferred embodiment, the length "l" is about 1.79 inches and the maximum diameter "d" is about 0.19 inches. This represents a reduction in length and diameter relative to a conventional anvil rod of about 45%, and about 57%, respectively.

Anvil component 604 is coupled to the circular anastomosis instrument through anvil adapter 618. With reference to FIGS. 33-35, anvil adapter 618 includes adapter rod 620 having tapered mounting portion 622 at one end for connection to the circular anastomosis instrument and external splines 624 to engage corresponding internal splines/grooves of the circular anastomosis instrument 100. The connection of anvil adapter 618 is similar to the connection of the anvil to the USSC PREMIUM CEEA™ instrument as disclosed in U.S. Pat. No. 5,119,983 or 5,718,360. As best depicted in FIGS. 33-34, an axial opening 626 adjacent the second end of adapter rod 620 extends to an intermediate portion of the rod 620. The axial opening 626 is defined by inwardly tapered walls 628 which extend into an enlarged inner cavity 630 of the opening. The juncture of the tapered walls 628 and inner cavity 630 defines an abutment surface 632. A plurality of internal splines 634 are disposed adjacent the second end of anvil rod 616 and extend in a general longitudinal direction. Upon assembly of anvil rod 616 and adapter 620, the tapered portion 617 of anvil rod is inserted within axial opening 626 of the adapter 618. As the rod 616 is advanced in the adapter 618 and passed through the narrowed opening defined by inner tapered walls 628, the tapered walls 628 are biased outwardly in a spring-like manner to permit passage of the tapered mounting portion 617 therethrough whereby upon clearance, the anvil rod 616 is locked within the adapter 618 by engagement of the tapered mounting portion 617 of the anvil rod with abutment surface 632 of adapter 618. During insertion, the external splines 624 of anvil rod are preferably aligned with the internal splines 634 of adapter 618 so as to received in interdigitating relation, thereby also rotationally fixing the anvil rod with respect to the adapter. As discussed hereinabove, the anvil adapter 618 permits the use of the reduced dimensioned anvil rod 616.

With reference again to FIG. 29, catheter guide 606 of apparatus 600 includes flexible outer member 636 which is preferably fabricated from a suitable polymeric material and defines a longitudinal bore 638 (shown in phantom) extending therethrough. Outer member 636 ranges in length from about 36 inches to about 60 inches to at least extend from the resected upper stomach section through the esophagus and out the mouth for engagement by the user. The distal end of outer member 636 is preformed to define an arched or curved section 640. Such configuration facilitates manipulation and

passage of catheter guide 606 through the esophagus and into the resected upper stomach portion. An atraumatic tip 642 is mounted to the distal end of outer member 636 and a coupler member 644 is attached to the proximal end of the outer member. As depicted in FIG. 31, the coupler member 644 includes an internal thread 646 at its proximal end which receives the externally threaded collar 622 of suture unit 608 to operatively connect the delivery apparatus 602 and the catheter guide 606. Coupler member 644 is preferably rotationally mounted about outer member 636 to facilitate threaded engagement of the coupler and collar members 644, 622. Catheter guide 606 may further include a guide wire which is receivable within the longitudinal opening of the outer member 636. Preferably, the guide wire is sufficient in length to extend from the distal end portion of the outer guide to the proximal end for engagement by the user. However, it is to be appreciated that the use of a guide wire is optional.

The use of the apparatus 600 will now be discussed. The upper stomach section "u" and the bowel "b₂" are resected in the manner discussed hereinabove in connection with FIGS. 7 and 8. With reference now to FIG. 36, initially, the catheter guide 606 and inserted guide wire "w", if used, is introduced within the oral cavity and passed through the esophageal passage "e" to be advanced within the upper stomach portion "u". It is noted that the curved distal portion 640 of the outer member 636 facilitates passage of the catheter guide 606 through manual manipulation and rotation of the outer member 636. Once the distal end of the outer member 636 accesses the upper stomach portion "u", the guide wire "w" is removed by retracting the guide wire in a proximal direction through the oral cavity. The delivery instrument 602 is then connected to the proximal end of the catheter guide 606 which extends from the mouth through the threaded interconnection of collar 622 of anvil component 604 and the coupler 644 of outer member 636 as discussed above.

With reference to FIG. 37, the surgeon then accesses the distal end of outer member 636 through an incision "o" or trocar accessing the upper stomach portion "u" and pulls the entire system 600 through the esophagus "e" in the direction of directional arrow "A". Accordingly, the anvil component 604 and attached delivery instrument 602 are passed through the esophageal tract "e". It is noted that the anvil head 610 is in its pivoted non-operative position to facilitate passage through the tract. The surgeon continues to advance the components until anvil component 604 is within the upper stomach section "u" and visible to the surgeon. Thereafter, the suture unit 608 attached to anvil component 604 is severed and removed from the anvil component 604, which thereby disconnects catheter guide 606 from the anvil component 604. The catheter guide 606 is discarded.

With reference to FIG. 38, bowel section "b₂" is positioned adjacent upper stomach section "u". A trocar "t" is introduced within an opening "o" in the bowel section "b₂". The circular anastomosis instrument 100 with attached adapter 618 is inserted in the trocar "t" and through an opening in the upper stomach portion "u".

Anvil adapter 618 is then mounted to anvil rod 616 of the anvil component 608. Delivery instrument 602 which extends through the esophagus such that its proximal end is exposed from the mouth is then actuated in the manner described in connection with the embodiment of FIGS. 23-28 to pivot the anvil head 610 to the operative position. The circular anastomosis instrument 100 and anvil head 610 are approximated and the instrument 100 fired to join the tissue portions in a manner previously described.

With reference to FIG. 39, anvil component 604 is released from anvil adapter 618. Delivery instrument 602 is actuated to

return the anvil head to the pivoted non-operative position. Thereafter, delivery instrument 602 with attached anvil component 604 is removed back through the esophagus and mouth in the direction B of FIG. 39.

Referring now to FIGS. 40-42, there is illustrated another alternate embodiment of the present disclosure. System 700 includes delivery instrument 702 and anvil assembly 704 releasably mounted to the delivery instrument 702. Anvil assembly 704 is substantially similar to the anvil assembly 604 described in connection with the embodiment of FIGS. 23-30, and reference is made thereto for particulars of the anvil assembly. Delivery instrument 702 includes handle 706 having handle half sections 706a, b attached to each other through adhesive screws, or the like, and elongated sleeve 708 connected to the handle 706 and extending distally therefrom. In a preferred embodiment, handle 706 includes externally threaded collar 710 mounted within the interior of the handle 706, which threadably engages corresponding internal threaded portion 710 of the elongated sleeve 708 to connect the two components. Other means for connecting are envisioned, including bayonet coupling, adhesives, etc. Handle 706 further possesses proximally positioned button 714 which functions to actuate a pivot mechanism for pivoting the anvil assembly 704, and manually engageable release button 716 which actuates a release mechanism for releasing anvil assembly 704 from the anastomosis instrument. The pivot and release mechanisms will be discussed in greater detail hereinbelow.

With reference now to FIGS. 41-43, the pivot mechanism is substantially similar to the pivot mechanism of the embodiment of FIG. 29 and includes pivot element 718 extending from button 714, and pivot rod 720 which is connected to the pivot element 718. Button 714 and pivot element 718 may be monolithically formed as a single unit as shown in the Figures. Pivot element 718 defines a semicircular open section 722 at its distal end to receive the proximal end of pivot rod 720. An internal circumferential rib 724 is integrally formed within the semicircular section 722 and is snap-fit into a circumferential groove 726 of pivot rod 720 to connect the two components.

The pivot mechanism further includes pivot link 728 which is received in a groove 730 defined at the distal end of pivot rod 720. Pivot link 728 is pivotally connected to pivot rod 720 through pin 732 and is further connected to anvil head 610 of anvil assembly through pin 734. The pivot mechanism moves in a longitudinal direction to cause corresponding pivotal movement of anvil head 610 between an operative position (FIG. 42) and a pivoted position (FIG. 43). The pivot mechanism is spring biased in the proximal direction corresponding to the operative position (FIG. 42) of the anvil assembly by coil spring 736. Coil spring 736 is coaxially arranged about pivot element 718 and engages, at its proximal end, abutment surface 738 of the pivot element 718 and, at its distal end, collar 740. Collar 740 is fixedly connected to the interior of handle portions 706a, b adjacent interior wall 741 of the handle 706. With this arrangement, coil spring 736 normally biases pivot element 718 and pivot button 714 in the proximal direction. The pivot mechanism may be releasably locked in the non-operative position by applying a radial directed force "r" to pivot button 714 to radially displace the button to the position depicted in FIG. 43. In this position, a locking shelf 714a of pivot button 714 engages a corresponding locking wall 707 of handle 706. Release of the pivot button 714 may be accomplished by radially displacing the pivot button 714 to its normal aligned position of FIG. 42.

With continued reference to FIGS. 40-43, the release mechanism for releasing anvil assembly 709 from its mount-

ing to the end-to-end anastomosis instrument will be discussed. The release mechanism includes the aforementioned release button 716, release collar 742 disposed within handle 706 and flexible release link 744 connected to the release collar 742 and extending distally to the anvil assembly 704. Release collar 742 defines an internal longitudinal bore 746 dimensioned to receive pivot element 718 of the pivot mechanism and permit reciprocal slidable longitudinal movement of the pivot element therewithin. Release collar 742 is fixed to release button 714 through corresponding mounting structure of the two components, e.g., tongue and groove arrangement, identified generally by reference numeral 748 in FIGS. 42-43. Release link 744, in turn, is operatively connected to release collar 742 through set screw 750 which is positioned to securely engage the proximal end of the release link 744. Set screw 750 also permits the operator to adjust the positioning of the release link 744 relative to the release button 716 to account for manufacturing tolerances, etc.

As best depicted in FIGS. 42-43, release link 744 is connected at its distal end to anvil release collar 752 which is coaxially positioned about the anvil rod 616 of anvil assembly 704. Such connection may be accomplished via conventional means, including adhesives or the like. Anvil release collar 752 moves relative to the anvil rod 616 upon corresponding longitudinal movement of release link 744 to thereby cause release of the anvil rod 616 relative to the anastomosis instrument, as will be discussed. The release mechanism is biased in a proximal direction by coil spring 754. Coil spring 754 engages, at its distal end, abutment wall 756 of handle 706 and engages, at its proximal end, abutment surface 758 of release collar 742 to normally bias the release collar 742 to the unactuated position depicted in FIG. 42. As shown in FIG. 44, the release mechanism is activated by advancing release button 716 distally against the influence of spring 754 which causes corresponding distal movement of release collar 742, release link 744 and anvil release collar 752. The relationship of anvil release collar 752 and anvil assembly 704 will be discussed hereinbelow.

Referring now to FIGS. 45-48, system 700 further includes light guide 760. Light guide or cable 760 is initially introduced through the esophagus to illuminate and/or visually inspect the operative site. Light guide 760 includes handle 762 and fibre cable 764 which extends distally from the handle 762. Handle 762 includes two distinct members, namely, proximal cap 766 and distal collar 768. Distal collar 768 defines a longitudinal bore 770 for reception of the proximal end of fiber cable 764 and is fixed to the fiber cable 764 by conventional means, including adhesives, crimping, etc. Distal collar 768 further includes an external threaded portion 772. Proximal cap 766 defines a longitudinal opening 774 and an internal threaded portion 776 which threadably engages the external threaded portion 772 of the distal collar 768 to connect the components.

Fiber cable 764 may be a single optical fiber as shown, or a plurality or bundle of fibers as appreciated by one skilled in the art. The optical fiber may be comprised of optical glass or polymeric matter. Fiber cable 764 extends to distal independent lens 778 which serves to focus the light emitted by the fiber cable 764. A collar 779 disposed adjacent the distal end of the fiber cable 764 mechanically couples the optical fiber and lens 778. Fiber cable 764 is connectable to a conventional light source "s" depicted in FIG. 45. Preferably, distal collar or adapter 768 is coupled to the light source in a conventional manner. Proximal cap 766 is attachable to the anvil assembly 704 through suture "s" (FIG. 46) as will be discussed.

With reference now to FIGS. 49-51, there is illustrated an embodiment of an anvil adapter 780 which is to be utilized

with the system 700 of the present invention. Anvil adapter 780 couples anvil assembly 704 to the circular anastomosis instrument (FIG. 5) utilized in accordance with the preferred surgical procedure. The anvil adapter 780 permits the use of an anvil rod which is significantly reduced in diameter and length as discussed in connection with the embodiment of FIG. 29 to facilitate passage of the anvil assembly through the esophagus. Anvil adapter 780 includes adapter rod 782 having tapered mounting portion 784 for connection to the anastomosis instrument. The end of adapter rod 782 opposite the mounting portion 784 includes a jaw mechanism 786 which couples with anvil rod 616 of the anvil assembly 704 to connect the anvil adapter 780 and the anvil assembly 704. Adapter rod 782 defines a central longitudinal bore 788 which extends to form slots 790 in opposed wall portions of the rod 782 as shown in FIG. 49. The jaw mechanism includes first and second opposed jaws 792 pivotally mounted within longitudinal bore 788 of adapter rod 782 through pivot pin 794 and extending through the slots 790 of the adapter rod 782. Jaws 792 move between an engaged position with respect to anvil rod 616 (FIG. 50) to engage the anvil rod 616 and a release position to release the anvil rod 616 as will be discussed.

Anvil adapter 780 further includes plunger 796 which is mounted within longitudinal bore 788. Plunger 796 is normally biased toward opposed jaws 792 by coil spring 798 which is coaxially mounted about one end portion of the plunger 796. The other end portion of plunger 796 defines an enlarged cylindrical head 800. Head 800 of plunger 796 normally engages under the influence of coil spring 798, inclined camming surfaces 802 of jaws 792 to bias the jaws 792 to the closed position depicted in FIGS. 50 and 51.

Anvil adapter 780 further includes ejector plate 804 disposed within the central longitudinal bore 788 adjacent plunger 796. Ejector plate 804 has an enlarged head 806 which is received within cylindrical opening 808 of plunger head 800, and an elongated portion 810 depending from the head 806. Elongated portion 810 has a longitudinal bore 812 which accommodates pivot pin 794 of the jaw mechanism. Ejector plate 804 is normally biased toward jaws 792 by coil spring 814 which is disposed in a longitudinal opening 816 of plunger 796. When anvil 616 is secured within anvil adapter 780, coil spring 814 is compressed through engagement of the distal tip 616 of anvil rod 616 and elongated portion 810 of ejector plate 804. Ejector plate 804 is adapted for limited longitudinal movement relative to adapter rod 782 to release the anvil adapter 780 from the anvil. In particular, anvil adapter 780 is released from anvil rod 616 of anvil assembly 704 by advancing release button 716 to the distal position of FIG. 44 which advances release collar 742, release link 744 and anvil release collar 752. With reference to FIGS. 52-53, as anvil release collar 752 advances, camming surfaces 752a of release collar 752 engage inner inclined surfaces 792a of jaws 792 to radially displace the jaws to the position depicted in FIG. 53. Once the jaws 792 clear the vertical surface 616a of anvil rod 616 adjacent the tapered mounting portion, the anvil rod 616 may be disengaged. Disengagement is facilitated through interaction of coil spring 814 and ejector plate 804 which moves proximally under influence of the compressed coil spring 814 to expel the anvil rod 616 in a proximal direction and released from the jaws 792 as detailed in FIG. 53. Thus, as appreciated, the releasing mechanism provides a positive expulsion force to eject anvil rod 616 from the anvil adapter 780 thereby obviating the need of the surgeon to forcibly separate the two components.

The use of system 700 will now be discussed. The upper stomach section "u" and the bowel "b₂" are resected in the

manner discussed hereinabove in connection with FIGS. 7 and 8. Light guide 760 is then advanced through a gastric tube (not shown) positioned in the esophagus to be advanced within the upper stomach section "u" in a similar manner to that described in connection with insertion of the guide wire "w" of FIG. 36. The light guide 760 is then energized whereby light emitted by the guide 760 is focused on the interior wall of the upper stomach section "u". The focused light provides a visual indicator to the surgeon as to location of the light guide 760 so as to guide the surgeon in forming the incision in the wall of the upper stomach section "u". The incision is preferably formed adjacent the lit area of the stomach wall such that subsequent to creating the incision, the surgeon can grasp the distal end of the light guide 760. The light guide is disconnected from the light source. The delivery instrument 702 with mounted anvil assembly 704 is connected to the proximal end of the light guide. With reference to FIG. 47, in accordance with the preferred procedure, proximal cap 766 of light guide 760 is connected to anvil assembly 704 with a suture "s" which is looped through the eye loop 766a of the cap 766 and passed through the aperture "a" of anvil rod 616 in a similar manner to that shown and described in connection with FIGS. 29 and 30. It is noted that in accordance with this embodiment, the suture "s" is not required to be looped through the anvil head 610 of the anvil as shown in FIG. 29 in that the anvil head 610 is releasably locked in the pivoted position as discussed hereinabove. With the anvil assembly 704 connected to the proximal end of the light guide 760, the light guide 760, anvil assembly 704 and mounted delivery instrument 702 is pulled through the esophagus in a similar manner to that described in connection with FIG. 37.

The surgeon continues to advance the components until anvil component 700 is within the upper stomach section "u" and visible to the surgeon. Thereafter, the suture attached to anvil assembly 704 is severed and removed, thereby detaching light guide 760 which is then removed.

The bowel section "b₂" is positioned with respect to the upper stomach section "u", and the circular anastomosis instrument with attached adapter 780 is inserted through the trocar in the same manner detailed in connection with the discussion of FIG. 38. The anvil rod 616 of the anvil assembly 704 is grasped with a grasping instrument. For example, FIGS. 54-55 illustrate a novel grasping forceps which can facilitate gripping engagement of the anvil rod 616. This forceps is disclosed in commonly assigned provisional application entitled SURGICAL JAWS, mailed Mar. 5, 2001 under Express Mail Certificate No. EL 765221053 US, the contents of which is incorporated herein by reference. The forceps jaws 900 permit grasping of the anvil rod 616 from a substantially aligned direct near zero degree approach.

The anvil rod 616 is then mounted within anvil adapter 780 by advancing anvil rod 616 between jaws 792 of the anvil adapter 780 whereby upon insertion the jaws 792 are displaced outwardly. Once the mounting portion of anvil rod 616 clears the jaws 792, the jaws 792 return to their normal position under the influence of coil spring 798 and plunger 796 whereby the jaws 792 engage the vertical surface 616a of the anvil rod 616 to effectuate mounting of the anvil rod 616 to the anvil adapter 780 (FIG. 50).

Delivery instrument 702 may then be activated by releasing button 714 to permit the button 714 to return under the influence of coil spring 736 to its normal position of FIG. 42 thereby causing corresponding proximal movement of pivot rod 720 and pivot link 728 which pivots anvil head 610 to the operative position. The circular anastomosis instrument and anvil assembly are thereafter approximated and the instrument is fired to join the tissue portions.

The release mechanism is thereafter actuated to release anvil rod 616 from anvil adapter 780 in the manner discussed above. Delivery instrument is activated to return anvil head 610 to the pivoted non-operative position. The delivery instrument 702 and anvil assembly 704 are removed through the esophagus "e".

While the above description contains many specifics, these specifics should not be construed as limitations on the scope of the disclosure, but merely as exemplifications of preferred embodiments thereof. Those skilled in the art will envision other modifications within the scope and spirit of the claims appended hereto.

What is claimed is:

1. An assembly for use with a surgical circular anastomosis instrument comprising an anvil rod and an anvil head having a plurality of pockets, the anvil head pivotable with respect to the anvil rod from a pivoted non-operative position to an operative position, the anvil rod extending from the anvil head, and a suture connected to the anvil head, the suture tensioning the anvil head in the pivoted non-operative position, wherein the anvil rod includes an aperture formed therein to receive the suture.

2. The assembly of claim 1, wherein the anvil head includes an opening formed therein to receive the suture.

3. The assembly of claim 2, wherein the suture passes through the aperture in the anvil rod, through the opening in the anvil head and back through the aperture of the anvil rod in a racetrack arrangement.

4. The assembly of claim 1, further comprising a connector member connected to the anvil rod, wherein the suture is connected to the connector member.

5. The assembly of claim 4, wherein the connector member connects the anvil rod to a guide member.

6. The assembly of claim 1, further comprising an anvil adapter connectable to the anvil rod at a first end and connectable to the circular anastomosis instrument at a second end.

7. The assembly of claim 6, wherein the anvil adapter includes an adapter rod having a distal opening therein dimensioned to receive a proximal portion of the anvil rod.

8. The assembly of claim 7, wherein the distal opening in the adapter rod includes inwardly tapered walls to lockingly engage the anvil rod.

9. The assembly of claim 7, wherein the anvil rod includes a series of splines engageable with splines formed in the adapter rod.

10. The assembly of claim 1, wherein the assembly is connectable to a delivery instrument.

11. An assembly for use with a surgical circular anastomosis instrument comprising an anvil rod and an anvil head having a plurality of pockets, the anvil head pivotable with respect to the anvil rod from a pivoted non-operative position to an operative position, the anvil rod extending from the anvil head, and a suture connected to the anvil head, the suture tensioning the anvil head in the pivoted non-operative position and a guide member, wherein the anvil rod is connected to the guide member for insertion to the surgical site, the guide member being flexible and including a longitudinal bore extending therein and has an atraumatic tip.

12. The assembly of claim 11, wherein the anvil rod is removably connected to the guide member.

13. The assembly of claim 12, wherein the suture is severable to detach the anvil rod from the guide member for subsequent attachment to a circular anastomosis instrument.

14. The assembly of claim 11, wherein the anvil head includes an opening formed therein to receive the suture.

15. The assembly of claim 11, wherein the anvil rod is removably connected to the guide member.

* * * * *

专利名称(译)	用于在消化系统中执行旁路手术的装置和方法		
公开(公告)号	US8317809	公开(公告)日	2012-11-27
申请号	US13/023604	申请日	2011-02-09
[标]申请(专利权)人(译)	诺兰TIM ARANWI摇奖 克林格JOHN RATCLIFF KEITH ROBERTSON约翰·查尔斯		
申请(专利权)人(译)	诺兰TIM ARANWI摇奖 克林格JOHN RATCLIFF KEITH ROBERTSON约翰·查尔斯		
当前申请(专利权)人(译)	COVIDIEN LP		
[标]发明人	NOLAN TIM ARANYI ERNIE KLINGER JOHN RATCLIFF KEITH ROBERTSON JOHN CHARLES		
发明人	NOLAN, TIM ARANYI, ERNIE KLINGER, JOHN RATCLIFF, KEITH ROBERTSON, JOHN CHARLES		
IPC分类号	A61B17/08 A61B17/04 A61B17/00 A61B17/072 A61B17/11 A61B17/115		
CPC分类号	A61B17/1114 A61B17/115 A61B17/07207 A61B2017/1139 A61B2017/07214 A61B2017/1135 A61B2017/00004		
优先权	11/640080 2011-03-08 US 10/234086 2007-02-20 US 60/187121 2000-03-06 US		
其他公开文献	US20110137325A1		
外部链接	Espacenet USPTO		

摘要(译)

用于在消化系统中执行旁路手术的手术器械和方法结合了腹腔镜技术以最小化对患者的手术创伤。所述器械包括外引导构件，所述外引导构件的尺寸适于插入并穿过患者的食道并且在其中限定至少沿着所述外引导构件的长度的一部分延伸的开口，细长的砧座递送构件至少部分地设置在所述开口内外引导构件的外部引导构件适于在外引导构件内在初始位置和致动位置之间纵向移动，并且砧座可与输送构件可操作地接合。砧座包括限定纵向轴线的砧座杆和连接到砧座杆的砧座头部。当处于输送构件的初始位置时，砧座头至少部分地设置在外引导构件的开口内，并且在输送构件移动到致动位置时，砧座头部完全从外引导构件的远端暴露。

