



US008317808B2

(12) **United States Patent**
Levin et al.

(10) **Patent No.:** **US 8,317,808 B2**
(45) **Date of Patent:** **Nov. 27, 2012**

(54) **DEVICE AND METHOD FOR ROLLING AND INSERTING A PROSTHETIC PATCH INTO A BODY CAVITY**

(75) Inventors: **Ofek Levin**, Moshav Amirim (IL); **Arie Levy**, Ramat-Gan (IL)

(73) Assignee: **Covidien LP**, Mansfield, MA (US)

(*) Notice: Subject to any disclaimer, the term of this patent is extended or adjusted under 35 U.S.C. 154(b) by 85 days.

(21) Appl. No.: **12/889,774**

(22) Filed: **Sep. 24, 2010**

(65) **Prior Publication Data**

US 2011/0034942 A1 Feb. 10, 2011

Related U.S. Application Data

(63) Continuation-in-part of application No. 12/834,456, filed on Jul. 12, 2010, which is a continuation-in-part of application No. PCT/IL2009/000188, filed on Feb. 18, 2009.

(60) Provisional application No. 61/029,386, filed on Feb. 18, 2008, provisional application No. 61/300,455, filed on Feb. 2, 2010.

(51) **Int. Cl.**

A61B 17/08 (2006.01)

A61F 2/02 (2006.01)

(52) **U.S. Cl.** **606/151**; 623/23.72

(58) **Field of Classification Search** 623/1.11, 623/23.72; 606/99, 151, 198; 600/29, 30, 600/37; 206/363, 438, 440, 441

See application file for complete search history.

(56) **References Cited**

U.S. PATENT DOCUMENTS

4,347,847 A	9/1982	Usher
4,400,833 A	8/1983	Kurland
4,452,245 A	6/1984	Usher
4,485,816 A	12/1984	Krumme
4,585,458 A	4/1986	Kurland
4,633,873 A	1/1987	Dumican et al.
4,838,884 A	6/1989	Dumican et al.
4,854,316 A	8/1989	Davis
5,019,096 A	5/1991	Fox, Jr. et al.
5,116,357 A	5/1992	Eberbach
5,122,155 A	6/1992	Eberbach
5,125,553 A	6/1992	Oddsens et al.
5,141,515 A	8/1992	Eberbach
5,147,374 A	9/1992	Fernandez
5,176,692 A	1/1993	Wilk et al.
5,203,864 A	4/1993	Phillips
5,219,077 A	6/1993	Transue
5,249,682 A	10/1993	Transue
5,254,133 A	10/1993	Seid
5,258,000 A	11/1993	Gianturco
5,263,969 A	11/1993	Phillips

(Continued)

FOREIGN PATENT DOCUMENTS

CA 2413904 A1 10/2003

(Continued)

OTHER PUBLICATIONS

US 6,503,260, 01/2003, Schaller et al. (withdrawn)

Primary Examiner — Julian Woo

(57) **ABSTRACT**

This invention generally relates to minimal invasive surgery. More specifically the current invention relates to an apparatus especially adapted to fold prosthetic patches and to insert said patches into a body cavity through a cannula or an incision.

16 Claims, 16 Drawing Sheets

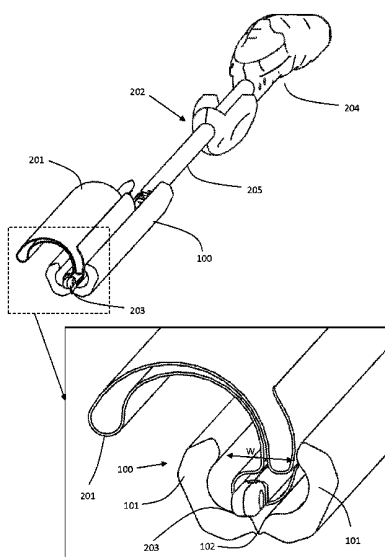

U.S. PATENT DOCUMENTS					
5,289,963 A	3/1994	McGarry et al.	6,258,113 B1	7/2001	Adams et al.
5,290,217 A	3/1994	Campos	6,258,124 B1	7/2001	Darois et al.
5,292,328 A	3/1994	Hain et al.	6,267,772 B1	7/2001	Mulhauser et al.
5,304,187 A	4/1994	Green et al.	6,280,453 B1	8/2001	Kugel et al.
5,333,624 A	8/1994	Tovey	6,287,316 B1	9/2001	Agarwal et al.
5,354,292 A	10/1994	Braeuer et al.	6,290,708 B1	9/2001	Kugel et al.
5,356,064 A	10/1994	Green et al.	6,312,442 B1	11/2001	Kieturakis et al.
5,356,432 A	10/1994	Rutkow et al.	6,319,264 B1	11/2001	Tormala et al.
5,364,002 A	11/1994	Green et al.	6,368,541 B1	4/2002	Pajotin et al.
5,364,004 A	11/1994	Davidson	6,375,662 B1	4/2002	Schmitt
5,366,460 A	11/1994	Eberbach	6,383,201 B1	5/2002	Dong
5,368,602 A	11/1994	de la Torre	6,391,060 B1	5/2002	Ory et al.
5,370,650 A	12/1994	Tovey et al.	6,408,656 B1	6/2002	Ory et al.
5,376,097 A	12/1994	Phillips	6,416,486 B1	7/2002	Wampler
5,383,477 A	1/1995	DeMatteis	6,425,900 B1	7/2002	Knodel et al.
5,392,978 A	2/1995	Velez et al.	6,425,924 B1	7/2002	Rousseau
5,397,331 A	3/1995	Himpens et al.	6,436,030 B2	8/2002	Rehil
5,405,360 A	4/1995	Tovey	6,447,524 B1	9/2002	Knodel et al.
5,425,357 A	6/1995	Mull et al.	6,478,803 B1	11/2002	Kapec et al.
5,425,740 A	6/1995	Hutchinson	6,485,503 B2	11/2002	Jacobs et al.
5,433,996 A	7/1995	Kranzler et al.	6,497,650 B1	12/2002	Nicolo
5,464,403 A	11/1995	Kieturakis et al.	6,517,584 B1	2/2003	Lecalve
5,497,933 A	3/1996	Defonzo et al.	6,527,785 B2	3/2003	Sancoff et al.
5,531,759 A	7/1996	Kensey et al.	6,551,241 B1	4/2003	Schultz
5,560,224 A	10/1996	Tessler	6,551,333 B2	4/2003	Kuhns et al.
5,560,532 A	10/1996	DeFonzo et al.	6,558,400 B2	5/2003	Deem et al.
5,564,615 A	10/1996	Bishop et al.	6,565,590 B2	5/2003	Kieturakis et al.
5,569,273 A	10/1996	Titone et al.	6,575,988 B2	6/2003	Rousseau
5,577,654 A	11/1996	Bishop	6,607,541 B1	8/2003	Gardiner et al.
5,588,580 A	12/1996	Paul et al.	6,610,006 B1	8/2003	Amid et al.
5,588,581 A	12/1996	Conlon et al.	6,613,059 B2	9/2003	Schaller et al.
5,601,224 A	2/1997	Bishop et al.	6,613,072 B2 *	9/2003	Lau et al. 623/1.11
5,614,284 A	3/1997	Kranzler et al.	6,616,685 B2	9/2003	Rousseau
5,618,290 A	4/1997	Toy et al.	6,638,208 B1	10/2003	Natarajan et al.
5,626,587 A	5/1997	Bishop et al.	6,638,284 B1	10/2003	Rousseau et al.
5,634,584 A	6/1997	Okorochoa et al.	6,638,292 B2	10/2003	Adams
5,634,931 A	6/1997	Kugel	6,638,297 B1	10/2003	Huitema
5,662,662 A	9/1997	Bishop et al.	6,652,595 B1	11/2003	Nicolo
5,695,525 A	12/1997	Mulhauser et al.	6,666,817 B2	12/2003	Li
5,716,409 A	2/1998	Debbas	6,669,706 B2	12/2003	Schmitt et al.
5,725,577 A	3/1998	Saxon	6,669,735 B1	12/2003	Pelissier
5,728,119 A	3/1998	Smith et al.	6,676,643 B2	1/2004	Brushey
5,749,895 A	5/1998	Sawyer et al.	6,689,047 B2	2/2004	Gellman
5,766,246 A	6/1998	Mulhauser et al.	6,694,192 B2	2/2004	Policker et al.
5,769,864 A	6/1998	Kugel	6,695,856 B2	2/2004	Kieturakis et al.
5,779,728 A	7/1998	Lunsford et al.	6,709,442 B2	3/2004	Miller et al.
5,810,851 A	9/1998	Yoon	6,736,823 B2	5/2004	Darois et al.
5,814,058 A	9/1998	Carlson et al.	6,736,854 B2	5/2004	Vadurro et al.
5,817,109 A	10/1998	McGarry et al.	6,737,371 B1	5/2004	Planck et al.
5,824,082 A	10/1998	Brown	6,746,458 B1	6/2004	Cloud
5,836,961 A	11/1998	Kieturakis et al.	6,755,867 B2	6/2004	Rousseau
5,854,383 A	12/1998	Ernetta et al.	6,773,438 B1	8/2004	Knodel et al.
5,863,531 A	1/1999	Naughton et al.	6,783,554 B2	8/2004	Amara et al.
5,865,728 A	2/1999	Moll et al.	6,790,213 B2	9/2004	Cherok et al.
5,911,726 A	6/1999	Belknap	6,800,081 B2	10/2004	Parodi
5,916,225 A	6/1999	Kugel	6,800,082 B2	10/2004	Rousseau
5,925,058 A	7/1999	Smith et al.	6,805,669 B2	10/2004	Swanbom
5,951,997 A	9/1999	Bezwada et al.	6,833,408 B2	12/2004	Sehl et al.
5,954,767 A	9/1999	Pajotin et al.	6,837,893 B2	1/2005	Miller
5,972,007 A	10/1999	Sheffield et al.	6,893,452 B2	5/2005	Jacobs
5,972,008 A	10/1999	Kalinski et al.	6,913,607 B2	7/2005	Ainsworth et al.
5,990,378 A	11/1999	Ellis	6,913,622 B2	7/2005	Gjunter
6,004,333 A	12/1999	Sheffield et al.	6,936,052 B2	8/2005	Gellman et al.
6,042,592 A	3/2000	Schmitt	6,945,980 B2	9/2005	Nguyen et al.
6,066,776 A	5/2000	Goodwin et al.	6,953,428 B2	10/2005	Gellman et al.
6,066,777 A	5/2000	Benchetrit	6,960,217 B2	11/2005	Bolduc
6,090,116 A	7/2000	D'Aversa et al.	6,960,233 B1	11/2005	Berg et al.
6,113,609 A	9/2000	Adams	6,966,916 B2	11/2005	Kumar
6,113,611 A	9/2000	Allen et al.	6,974,586 B2	12/2005	Greenhalgh et al.
6,113,624 A	9/2000	Bezwada et al.	6,991,597 B2	1/2006	Gellman et al.
6,166,286 A	12/2000	Trabucco	7,001,405 B2	2/2006	Kieturakis et al.
6,171,318 B1	1/2001	Kugel et al.	7,011,688 B2	3/2006	Gryska et al.
6,174,320 B1	1/2001	Kugel et al.	7,025,772 B2	4/2006	Gellman et al.
6,176,863 B1	1/2001	Kugel et al.	7,049,345 B2	5/2006	Holmes-Farley
6,197,036 B1	3/2001	Tripp et al.	7,077,850 B2	7/2006	Kortenbach
6,214,020 B1	4/2001	Mulhauser et al.	7,083,629 B2	8/2006	Weller et al.
6,224,616 B1	5/2001	Kugel	7,083,630 B2	8/2006	DeVries et al.
6,241,768 B1	6/2001	Agarwal et al.	7,094,261 B2	8/2006	Zotti et al.
			7,101,366 B2	9/2006	Trout, III et al.

7,101,381	B2	9/2006	Ford et al.	2003/0120299	A1	6/2003	Kieturakis et al.
7,119,062	B1	10/2006	Alvis et al.	2003/0130745	A1	7/2003	Cherok et al.
7,148,315	B2	12/2006	Erneta et al.	2003/0166628	A1	9/2003	Doyle et al.
7,198,046	B1	4/2007	Argenta et al.	2003/0171761	A1	9/2003	Sancoff et al.
7,214,236	B2	5/2007	Kieturakis et al.	2003/0171812	A1	9/2003	Grunberg et al.
7,216,651	B2	5/2007	Argenta et al.	2003/0171823	A1	9/2003	Zotti et al.
7,220,282	B2	5/2007	Kuslich	2003/0187516	A1	10/2003	Amid et al.
7,229,452	B2	6/2007	Kayan	2003/0195531	A1	10/2003	Gardiner et al.
7,235,043	B2	6/2007	Gellman et al.	2003/0208211	A1	11/2003	Kortenbach
7,235,295	B2	6/2007	Laurencin et al.	2003/0212460	A1	11/2003	Darois et al.
7,255,675	B2	8/2007	Gertner et al.	2003/0212461	A1	11/2003	Vadurro et al.
7,320,325	B2	1/2008	Duchon et al.	2003/0212462	A1	11/2003	Gryska et al.
7,331,199	B2	2/2008	Ory et al.	2003/0220660	A1	11/2003	Kortenbach et al.
7,381,225	B2	6/2008	Croce et al.	2003/0225355	A1	12/2003	Butler
7,404,819	B1	7/2008	Darios et al.	2003/0225420	A1	12/2003	Wardle
7,406,969	B2	8/2008	Duchon et al.	2004/0002679	A1	1/2004	Trout et al.
7,407,480	B2	8/2008	Staskin et al.	2004/0010317	A1	1/2004	Lambrech et al.
7,485,129	B2	2/2009	Eisenkolb	2004/0019360	A1	1/2004	Farnsworth et al.
7,491,232	B2	2/2009	Bolduc et al.	2004/0024386	A1	2/2004	Deem et al.
7,500,945	B2	3/2009	Cox et al.	2004/0024465	A1	2/2004	Lambrech et al.
7,500,993	B2	3/2009	De La Torre et al.	2004/0030217	A1	2/2004	Yeung et al.
7,524,333	B2	4/2009	Lambrech et al.	2004/0039453	A1	2/2004	Anderson et al.
7,544,213	B2	6/2009	Adams	2004/0044364	A1	3/2004	DeVries et al.
7,553,329	B2	6/2009	Lambrech et al.	2004/0044412	A1	3/2004	Lambrech et al.
7,553,330	B2	6/2009	Lambrech et al.	2004/0049227	A1	3/2004	Jervis
RE40,833	E	7/2009	Wintermantel et al.	2004/0049282	A1	3/2004	Gjunter
7,566,337	B2	7/2009	Sogaard-Andersen et al.	2004/0054376	A1	3/2004	Ory et al.
7,594,921	B2	9/2009	Browning	2004/0059356	A1	3/2004	Gingras
7,601,118	B2	10/2009	Smith et al.	2004/0064131	A1	4/2004	Brushey
7,601,172	B2	10/2009	Segal et al.	2004/0073237	A1	4/2004	Leinsing
2001/0016754	A1	8/2001	Adams et al.	2004/0073257	A1	4/2004	Spitz
2001/0018592	A1	8/2001	Schaller et al.	2004/0082755	A1	4/2004	Erneta et al.
2001/0018593	A1	8/2001	Nguyen et al.	2004/0087970	A1	5/2004	Chu et al.
2001/0027347	A1	10/2001	Rousseau	2004/0087979	A1	5/2004	Field et al.
2001/0044637	A1	11/2001	Jacobs et al.	2004/0087980	A1	5/2004	Ford et al.
2001/0049538	A1	12/2001	Trabucco	2004/0092937	A1	5/2004	Criscuolo et al.
2001/0049539	A1	12/2001	Rehil	2004/0092969	A1	5/2004	Kumar
2001/0053919	A1	12/2001	Kieturakis et al.	2004/0092970	A1	5/2004	Xavier
2001/0056275	A1	12/2001	Brushey	2004/0097924	A1	5/2004	Lambrech et al.
2002/0010457	A1	1/2002	Duchon et al.	2004/0097986	A1	5/2004	Adams
2002/0010480	A1	1/2002	Sancoff et al.	2004/0122452	A1	6/2004	Deem et al.
2002/0010490	A1	1/2002	Schaller et al.	2004/0122453	A1	6/2004	Deem et al.
2002/0010494	A1	1/2002	Policker et al.	2004/0133214	A1	7/2004	Kayan
2002/0029048	A1	3/2002	Miller	2004/0144395	A1	7/2004	Evans et al.
2002/0042658	A1	4/2002	Tyagi	2004/0152977	A1	8/2004	Duchon et al.
2002/0049503	A1	4/2002	Milbocker	2004/0152978	A1	8/2004	Duchon et al.
2002/0049504	A1	4/2002	Barault	2004/0172048	A1	9/2004	Browning
2002/0052612	A1	5/2002	Schmitt et al.	2004/0181288	A1	9/2004	Darois et al.
2002/0052654	A1	5/2002	Darois et al.	2004/0193043	A1	9/2004	Duchon et al.
2002/0058967	A1	5/2002	Jervis	2004/0215219	A1	10/2004	Eldridge et al.
2002/0065524	A1	5/2002	Miller et al.	2004/0225247	A1	11/2004	Pugsley et al.
2002/0066360	A1	6/2002	Greenhalgh et al.	2004/0225373	A1	11/2004	Pugsley et al.
2002/0077652	A1	6/2002	Kieturakis et al.	2004/0230208	A1	11/2004	Shayani
2002/0082621	A1	6/2002	Schurr et al.	2004/0234576	A1	11/2004	Martin et al.
2002/0087170	A1	7/2002	Kuhns et al.	2004/0249412	A1	12/2004	Snow et al.
2002/0091405	A1	7/2002	Kieturakis et al.	2004/0254592	A1	12/2004	DiCarlo et al.
2002/0103434	A1	8/2002	Swanbom	2005/0004427	A1	1/2005	Cervigni
2002/0103494	A1	8/2002	Pacey	2005/0010239	A1	1/2005	Chefitz
2002/0107539	A1	8/2002	Kieturakis et al.	2005/0010306	A1	1/2005	Priewe et al.
2002/0116070	A1	8/2002	Amara et al.	2005/0015102	A1	1/2005	Chefitz
2002/0117534	A1	8/2002	Green et al.	2005/0019436	A1	1/2005	Burch et al.
2002/0147457	A1	10/2002	Rousseau	2005/0021058	A1	1/2005	Negro
2002/0165561	A1	11/2002	Ainsworth et al.	2005/0027369	A1	2/2005	Eldridge et al.
2002/0169452	A1	11/2002	Tormala et al.	2005/0033318	A1	2/2005	Miller et al.
2002/0173803	A1	11/2002	Ainsworth et al.	2005/0038452	A1	2/2005	Chu
2002/0173804	A1	11/2002	Rousseau	2005/0054771	A1	3/2005	Sehl et al.
2002/0183765	A1	12/2002	Adams	2005/0055097	A1	3/2005	Grunberg et al.
2002/0183768	A1	12/2002	Deem et al.	2005/0060038	A1	3/2005	Lambrech et al.
2002/0188317	A1	12/2002	Rousseau	2005/0065072	A1	3/2005	Keeler et al.
2003/0004581	A1	1/2003	Rousseau	2005/0075667	A1	4/2005	Schaller et al.
2003/0039626	A1	2/2003	Holmes-Farley	2005/0080454	A1	4/2005	Drews et al.
2003/0065359	A1	4/2003	Weller et al.	2005/0113849	A1	5/2005	Popadiuk et al.
2003/0073976	A1	4/2003	Brushey	2005/0113858	A1	5/2005	Deutsch
2003/0078602	A1	4/2003	Rousseau	2005/0118239	A1	6/2005	Sabesan
2003/0078603	A1	4/2003	Schaller et al.	2005/0129733	A1	6/2005	Milbocker et al.
2003/0105473	A1	6/2003	Miller	2005/0142315	A1	6/2005	DeSimone et al.
2003/0109892	A1	6/2003	Deem et al.	2005/0143817	A1	6/2005	Hunter et al.
2003/0119985	A1	6/2003	Sehl et al.	2005/0149072	A1	7/2005	DeVries et al.
2003/0120265	A1	6/2003	Deem et al.	2005/0149080	A1	7/2005	Hunter et al.

2005/0149158	A1	7/2005	Hunter et al.	2007/0038310	A1	2/2007	Guetty
2005/0154361	A1	7/2005	Sabesan	2007/0100355	A1	5/2007	Bonde et al.
2005/0159777	A1	7/2005	Spitz	2007/0110786	A1	5/2007	Tenney et al.
2005/0165425	A1	7/2005	Croce et al.	2007/0111937	A1	5/2007	Pickar et al.
2005/0165488	A1	7/2005	Hunter et al.	2007/0118133	A1	5/2007	Lambrech et al.
2005/0169959	A1	8/2005	Hunter et al.	2007/0118158	A1	5/2007	Deem et al.
2005/0175663	A1	8/2005	Hunter et al.	2007/0118159	A1	5/2007	Deem et al.
2005/0177225	A1	8/2005	Hunter et al.	2007/0122425	A1	5/2007	Keeler et al.
2005/0181008	A1	8/2005	Hunter et al.	2007/0134292	A1	6/2007	Suokas et al.
2005/0181011	A1	8/2005	Hunter et al.	2007/0135929	A1	6/2007	Williams et al.
2005/0181977	A1	8/2005	Hunter et al.	2007/0156245	A1	7/2007	Cauthen et al.
2005/0183728	A1	8/2005	Hunter et al.	2007/0162030	A1	7/2007	Arony et al.
2005/0191331	A1	9/2005	Hunter et al.	2007/0162135	A1	7/2007	Segal et al.
2005/0192600	A1	9/2005	Nicolo et al.	2007/0167963	A1	7/2007	Deem et al.
2005/0202067	A1	9/2005	Lendlein et al.	2007/0173864	A1	7/2007	Chu
2005/0222591	A1	10/2005	Gingras et al.	2007/0173888	A1	7/2007	Gertner et al.
2005/0228408	A1	10/2005	Fricke et al.	2007/0179335	A1	8/2007	Gertner et al.
2005/0234557	A1	10/2005	Lambrech et al.	2007/0184277	A1	8/2007	Schussler et al.
2005/0240269	A1	10/2005	Lambrech et al.	2007/0185506	A1	8/2007	Jackson
2005/0244455	A1	11/2005	Greenawalt	2007/0185541	A1	8/2007	DiUbaldi et al.
2005/0245787	A1	11/2005	Cox et al.	2007/0198040	A1	8/2007	Buevich et al.
2005/0249770	A1	11/2005	Hunter	2007/0202148	A1	8/2007	Ringelsen et al.
2005/0267325	A1	12/2005	Bouchier et al.	2007/0202173	A1	8/2007	Cueto-Garcia
2005/0271794	A1	12/2005	DeSimone et al.	2007/0203507	A1	8/2007	McLaughlin et al.
2005/0273146	A1	12/2005	DeSimone et al.	2007/0207186	A1	9/2007	Scanlon et al.
2005/0283189	A1	12/2005	Rosenblatt	2007/0208358	A1	9/2007	Kayan
2005/0283190	A1	12/2005	Huitema et al.	2007/0219569	A1	9/2007	Shayani
2005/0283246	A1	12/2005	Cauthen et al.	2007/0225791	A1	9/2007	Molitor et al.
2005/0283962	A1	12/2005	Boudjemline	2007/0244502	A1	10/2007	Deutsch
2005/0288691	A1	12/2005	Leiboff	2007/0250147	A1	10/2007	Walther et al.
2005/0288775	A1	12/2005	Dong	2007/0260179	A1	11/2007	Sholev et al.
2006/0009802	A1	1/2006	Modesitt	2007/0260268	A1	11/2007	Bartee et al.
2006/0015142	A1	1/2006	Malazgirt	2007/0265710	A1	11/2007	Brown et al.
2006/0015143	A1	1/2006	Alvarado	2007/0270752	A1	11/2007	LaBombard
2006/0024238	A1	2/2006	Barth et al.	2007/0280990	A1	12/2007	Stopek
2006/0025649	A1	2/2006	Smith et al.	2007/0293717	A1	12/2007	Kaletka et al.
2006/0039896	A1	2/2006	Kleinsek et al.	2007/0293878	A1	12/2007	Butsch
2006/0047180	A1	3/2006	Hegde et al.	2007/0299300	A1	12/2007	Smith et al.
2006/0052816	A1	3/2006	Bates et al.	2007/0299542	A1	12/2007	Mathisen et al.
2006/0064175	A1	3/2006	Pelissier et al.	2008/0015501	A1	1/2008	Gertner
2006/0079558	A1	4/2006	Aberg et al.	2008/0021545	A1	1/2008	Reneker et al.
2006/0079559	A1	4/2006	Aberg et al.	2008/0033461	A1	2/2008	Koeckerling et al.
2006/0083710	A1	4/2006	Joerger et al.	2008/0035243	A1	2/2008	Breitenkamp et al.
2006/0105026	A1	5/2006	Fortune et al.	2008/0045952	A1	2/2008	Kuslich
2006/0116696	A1	6/2006	Odermatt et al.	2008/0065229	A1	3/2008	Adams
2006/0122637	A1	6/2006	Barker	2008/0086216	A1	4/2008	Wilson et al.
2006/0127353	A1	6/2006	Holmes-Farley	2008/0091222	A1	4/2008	Deusch et al.
2006/0129152	A1	6/2006	Shipp	2008/0091276	A1	4/2008	Deusch et al.
2006/0129154	A1	6/2006	Shipp	2008/0103351	A1	5/2008	Montpetit et al.
2006/0142787	A1	6/2006	Weller et al.	2008/0113035	A1	5/2008	Hunter
2006/0147488	A1	7/2006	Wohlert	2008/0125869	A1	5/2008	Paz et al.
2006/0147492	A1	7/2006	Hunter et al.	2008/0131509	A1	6/2008	Hossainy et al.
2006/0149316	A1	7/2006	DeVries et al.	2008/0132602	A1	6/2008	Rizk et al.
2006/0155165	A1	7/2006	Vanden Hoek et al.	2008/0147198	A1	6/2008	Cherok et al.
2006/0155379	A1	7/2006	Heneveld et al.	2008/0147200	A1	6/2008	Rousseau et al.
2006/0177489	A1	8/2006	Massouda et al.	2008/0167519	A1	7/2008	St-Germain
2006/0189918	A1	8/2006	Barker	2008/0167667	A1	7/2008	Criscuolo et al.
2006/0200246	A1	9/2006	Lambrech et al.	2008/0167668	A1	7/2008	Criscuolo et al.
2006/0206118	A1	9/2006	Kim et al.	2008/0188874	A1	8/2008	Henderson
2006/0206178	A1	9/2006	Kim	2008/0193494	A1	8/2008	Sabesan
2006/0210602	A1	9/2006	Sehl et al.	2008/0195121	A1	8/2008	Eldar et al.
2006/0217812	A1	9/2006	Lambrech et al.	2008/0200979	A1	8/2008	Dieck et al.
2006/0228391	A1	10/2006	Seyedin et al.	2008/0215154	A1	9/2008	Lambrech et al.
2006/0233852	A1	10/2006	Milbocker	2008/0243149	A1	10/2008	Koeckerling et al.
2006/0240063	A9	10/2006	Hunter et al.	2008/0255593	A1	10/2008	St-Germain
2006/0251702	A1	11/2006	Janis et al.	2008/0260794	A1	10/2008	Lauritzen et al.
2006/0253203	A1	11/2006	Alvarado	2008/0269896	A1	10/2008	Cherok et al.
2006/0264698	A1	11/2006	Kondonis et al.	2008/0281433	A1	11/2008	Chang et al.
2006/0282103	A1	12/2006	Fricke et al.	2008/0287970	A1	11/2008	Amato et al.
2006/0282105	A1	12/2006	Ford et al.	2008/0306497	A1	12/2008	Brown et al.
2006/0287729	A1	12/2006	Segal et al.	2008/0312751	A1	12/2008	Pugsley et al.
2006/0287730	A1	12/2006	Segal et al.	2009/0004239	A1	1/2009	Ladet et al.
2007/0016300	A1	1/2007	Kuslich	2009/0005867	A1	1/2009	Lefranc et al.
2007/0021756	A1	1/2007	Kortenbach	2009/0012350	A1	1/2009	Tihon
2007/0026043	A1	2/2007	Guan et al.	2009/0012546	A1	1/2009	N'diaye et al.
2007/0027358	A1	2/2007	Gertner et al.	2009/0018559	A1	1/2009	Buevich et al.
2007/0032881	A1	2/2007	Browning	2009/0030434	A1	1/2009	Paz et al.
2007/0036876	A1	2/2007	Burch et al.	2009/0030522	A1	1/2009	Cauthen, III et al.
2007/0038220	A1	2/2007	Shipp	2009/0030527	A1	1/2009	Richter

2009/0036937	A1	2/2009	Cauthen, III et al.	EP	1674048	A1	6/2006
2009/0036989	A1	2/2009	Cauthen, III et al.	EP	1274473	B1	7/2006
2009/0036990	A1	2/2009	Cauthen, III et al.	EP	0934024	B1	8/2006
2009/0036996	A1	2/2009	Roeber	EP	1503683	B1	8/2006
2009/0062823	A1	3/2009	Richter	EP	1700579	A1	9/2006
2009/0069826	A1	3/2009	Walther et al.	EP	1704832	A2	9/2006
2009/0105526	A1	4/2009	Piroli Torelli et al.	EP	200614650	A2	10/2006
2009/0125041	A1	5/2009	Dudai	EP	1079741	B1	11/2006
2009/0137864	A1	5/2009	Cox et al.	EP	0964645	B1	7/2007
2009/0149875	A1	6/2009	Abele et al.	EP	1163019	B1	10/2007
2009/0155332	A1	6/2009	Sherry et al.	EP	1849440	A1	10/2007
2009/0157184	A1	6/2009	Cauthen, III et al.	EP	1867348	A2	12/2007
2009/0157195	A1	6/2009	Siedle	EP	1870056	A1	12/2007
2009/0162273	A1	6/2009	Lawrynowicz et al.	EP	1531739	B1	2/2008
2009/0182190	A1	7/2009	Dann	EP	1406557	B1	11/2008
2009/0182338	A1	7/2009	Paz et al.	EP	1990014	A2	11/2008
2009/0187258	A1	7/2009	Ip et al.	EP	2002800	A1	12/2008
2009/0192346	A1	7/2009	Rosenblatt	EP	1505927	B1	1/2009
2009/0192528	A1	7/2009	Higgins et al.	EP	1372525	B1	3/2009
2009/0198260	A1	8/2009	Ford et al.	EP	1653880	B1	4/2009
2009/0204130	A1	8/2009	Kantsevoy et al.	EP	2050474	A2	4/2009
2009/0204227	A1	8/2009	Derwin et al.	EP	1940312	B1	7/2009
2009/0216075	A1	8/2009	Bell et al.	FR	2789888	A1	8/2000
2009/0216104	A1	8/2009	DeSimone et al.	WO	WO8204390	A1	12/1982
2009/0216338	A1	8/2009	Gingras et al.	WO	WO92/06639		4/1992
2009/0234379	A1	9/2009	Rehnke	WO	WO9206639	A2	4/1992
2009/0234461	A1	9/2009	Rehnke	WO	WO9211824	A1	7/1992
2009/0240342	A1	9/2009	Lindh et al.	WO	WO9219162	A2	11/1992
2009/0240343	A1	9/2009	Adams	WO	WO9221293	A1	12/1992
2009/0248048	A1	10/2009	Milbocker	WO	WO9303685	A1	3/1993
2009/0254103	A1	10/2009	Deutsch	WO	WO9309722	A1	5/1993
2009/0259094	A1	10/2009	Bouchier et al.	WO	WO9317635	A1	9/1993
				WO	WO9417747	A1	8/1994
				WO	WO9419029	A1	9/1994
				WO	WO9427535	A1	12/1994
				WO	WO95/30374		11/1995
				WO	WO9530374	A1	11/1995
				WO	WO9531140	A1	11/1995
				WO	WO9603091	A1	2/1996
				WO	WO9603165	A1	2/1996
				WO	WO9606634	A1	3/1996
				WO	WO9609795	A1	4/1996
				WO	WO9640307	A1	12/1996
				WO	WO9702789	A1	1/1997
				WO	WO9722371	A1	6/1997
				WO	WO9732526	A1	9/1997
				WO	WO9735533	A1	10/1997
				WO	WO9803713	A1	1/1998
				WO	WO9811814		3/1998
				WO	WO9814134	A2	4/1998
				WO	WO9816153	A1	4/1998
				WO	WO9903422	A1	1/1999
				WO	WO9905992	A1	2/1999
				WO	WO9916381	A1	4/1999
				WO	WO9951163	A1	10/1999
				WO	WO9960931	A1	12/1999
				WO	WO9962406	A2	12/1999
				WO	WO9963051	A2	12/1999
				WO	WO0007520	A1	2/2000
				WO	WO0016822	A2	3/2000
				WO	WO0056376	A1	9/2000
				WO	WO0057796	A1	10/2000
				WO	WO0057812	A1	10/2000
				WO	WO0061033		10/2000
				WO	WO0067663	A1	11/2000
				WO	WO0071548	A1	11/2000
				WO	WO0071549	A1	11/2000
				WO	WO0108594	A1	2/2001
				WO	WO0126588	A2	4/2001
				WO	WO0154589	A1	8/2001
				WO	WO0168653	A1	9/2001
				WO	WO0170322	A1	9/2001
				WO	WO0180788	A2	11/2001
				WO	WO0185058	A2	11/2001
				WO	WO0185060		11/2001
				WO	WO0189390	A1	11/2001
				WO	WO0189392	A2	11/2001
				WO	WO0207648	A1	1/2002
				WO	WO0217771	A2	3/2002

FOREIGN PATENT DOCUMENTS

EP	0328421	A2	8/1989
EP	0525791	A1	2/1993
EP	0537769	A1	4/1993
EP	0544485	A1	6/1993
EP	0556018	A1	8/1993
EP	0557964	A1	9/1993
EP	0573273		12/1993
EP	0573273	A2	12/1993
EP	0579377	A2	1/1994
EP	0581036		2/1994
EP	0581036	A1	2/1994
EP	0614650	A2	9/1994
EP	0702934	A1	3/1996
EP	0744162	A2	11/1996
EP	0519022	B1	12/1997
EP	0827724	A2	3/1998
EP	0553344	B1	9/1998
EP	0746258	B1	9/1998
EP	0898944	A2	3/1999
EP	0908482	A1	4/1999
EP	0986993	A1	3/2000
EP	0837660	B1	5/2000
EP	1060714	A2	12/2000
EP	1145693	A2	10/2001
EP	1181899	A2	2/2002
EP	1199037	A2	4/2002
EP	1199038	A2	4/2002
EP	1219265		7/2002
EP	1219265	A2	7/2002
EP	0746267	B1	11/2002
EP	1018980	B1	1/2003
EP	1306061	A2	5/2003
EP	1317904	A1	6/2003
EP	1366717	A1	12/2003
EP	0783270	B1	6/2004
EP	1200010	B1	3/2005
EP	1164967	B1	5/2005
EP	1541183	A1	6/2005
EP	WO2005082273	A1	9/2005
EP	0828453	B1	11/2005
EP	1001717	B1	11/2005
EP	1303230	B1	11/2005
EP	1607048	A1	12/2005
EP	1404250	B1	2/2006
EP	1671604	A2	6/2006

WO	WO0217796	A1	3/2002	WO	WO2005079335	A2	9/2005
WO	WO0217797	A1	3/2002	WO	WO2005082274	A1	9/2005
WO	WO0219916	A1	3/2002	WO	WO2005094721	A1	10/2005
WO	WO0219923	A1	3/2002	WO	WO2005099628	A2	10/2005
WO	WO0222047	A1	3/2002	WO	WO2005102209	A1	11/2005
WO	WO02224080	A2	3/2002	WO	WO2005105172	A1	11/2005
WO	WO0226747	A1	4/2002	WO	WO2005110243	A2	11/2005
WO	WO0230336	A2	4/2002	WO	WO2005110273	A1	11/2005
WO	WO0232346	A1	4/2002	WO	WO2006002439	A1	1/2006
WO	WO0234140	A2	5/2002	WO	WO2006008429	A1	1/2006
WO	WO0235990	A2	5/2002	WO	WO2006012353	A2	2/2006
WO	WO02058543	A2	8/2002	WO	WO2006013337	A2	2/2006
WO	WO02078568	A1	10/2002	WO	WO2006015031	A2	2/2006
WO	WO02080779	A1	10/2002	WO	WO2006026509	A2	3/2006
WO	WO02080780	A1	10/2002	WO	WO2006034117	A1	3/2006
WO	WO02087425	A2	11/2002	WO	WO2006036936	A2	4/2006
WO	WO02091928	A1	11/2002	WO	WO2006037047	A2	4/2006
WO	WO02091953	A1	11/2002	WO	WO2006040760	A2	4/2006
WO	WO02096327	A2	12/2002	WO	WO2006044785	A1	4/2006
WO	WO03002029	A1	1/2003	WO	WO2006047645	A2	5/2006
WO	WO03002130	A1	1/2003	WO	WO2006048885	A1	5/2006
WO	WO03032867	A1	4/2003	WO	WO2006/082587		8/2006
WO	WO03059180	A2	7/2003	WO	WO2006082587	A2	8/2006
WO	WO03059201	A1	7/2003	WO	WO2006086339	A2	8/2006
WO	WO03059217	A1	7/2003	WO	WO2006092159	A1	9/2006
WO	WO03077730	A2	9/2003	WO	WO2006092236	A1	9/2006
WO	WO03082125	A1	10/2003	WO	WO2006102457	A2	9/2006
WO	WO03084410	A1	10/2003	WO	WO2006116000	A2	11/2006
WO	WO03088846	A1	10/2003	WO	WO2006119034	A2	11/2006
WO	WO03090633	A2	11/2003	WO	WO2007004228	A1	1/2007
WO	WO03092509	A1	11/2003	WO	WO2007011689	A2	1/2007
WO	WO03094781	A1	11/2003	WO	WO2007017872	A2	2/2007
WO	WO03094783	A1	11/2003	WO	WO2007021620	A2	2/2007
WO	WO03094786	A1	11/2003	WO	WO2007021759	A2	2/2007
WO	WO03094787	A1	11/2003	WO	WO2007021834	A1	2/2007
WO	WO03096909	A1	11/2003	WO	WO2007/030676		3/2007
WO	WO03096929	A1	11/2003	WO	WO2007025293	A2	3/2007
WO	WO03097011	A1	11/2003	WO	WO2007025296	A2	3/2007
WO	WO03099160	A1	12/2003	WO	WO2007025302	A2	3/2007
WO	WO03103473	A2	12/2003	WO	WO2007030676	A2	3/2007
WO	WO2004004600	A1	1/2004	WO	WO2007034145	A2	3/2007
WO	WO2004006808	A2	1/2004	WO	WO2007050382	A1	5/2007
WO	WO2004012579	A2	2/2004	WO	WO2007051221	A1	5/2007
WO	WO2004012627	A1	2/2004	WO	WO2007055755	A1	5/2007
WO	WO2004019787	A2	3/2004	WO	WO2007070141	A1	6/2007
WO	WO2004024030	A1	3/2004	WO	WO2007072469	A2	6/2007
WO	WO2004034924	A2	4/2004	WO	WO2007081955	A1	7/2007
WO	WO2004/037123		5/2004	WO	WO2007087132	A1	8/2007
WO	WO2004037123	A1	5/2004	WO	WO2007087146	A2	8/2007
WO	WO2004058286	A1	7/2004	WO	WO2007115110	A2	10/2007
WO	WO20040660425	A2	7/2004	WO	WO2007129220	A2	11/2007
WO	WO2004062529	A2	7/2004	WO	WO2007133311	A2	11/2007
WO	WO2004062530	A1	7/2004	WO	WO2007136820	A2	11/2007
WO	WO2004028547	A1	8/2004	WO	WO2007137211	A2	11/2007
WO	WO2004069866	A1	8/2004	WO	WO2007143726	A2	12/2007
WO	WO2004/080348		9/2004	WO	WO2007144782	A2	12/2007
WO	WO2004080348	A1	9/2004	WO	WO2007146784	A2	12/2007
WO	WO2004087227	A1	10/2004	WO	WO2008006097	A2	1/2008
WO	WO2004093737	A1	11/2004	WO	WO2008016802	A1	2/2008
WO	WO2004098461	A2	11/2004	WO	WO2008026905	A2	3/2008
WO	WO2004098665	A1	11/2004	WO	WO2008030873	A2	3/2008
WO	WO2004100841	A1	11/2004	WO	WO2008030939	A2	3/2008
WO	WO2004101002	A2	11/2004	WO	WO2008/045635		4/2008
WO	WO2004103166	A2	12/2004	WO	WO2008045635	A2	4/2008
WO	WO2004103414	A2	12/2004	WO	WO2008055028	A1	5/2008
WO	WO2005003351	A1	1/2005	WO	WO2008065653	A1	6/2008
WO	WO2005004727	A1	1/2005	WO	WO2008069919	A2	6/2008
WO	WO2005007209	A1	1/2005	WO	WO2008083484	A1	7/2008
WO	WO2005014634	A1	2/2005	WO	WO2008085825	A1	7/2008
WO	WO2005018494	A1	3/2005	WO	WO2008/099382		8/2008
WO	WO2005019241	A2	3/2005	WO	WO2008094217	A1	8/2008
WO	WO2005019315	A1	3/2005	WO	WO2008094842	A1	8/2008
WO	WO2005035548	A1	4/2005	WO	WO2008099382	A1	8/2008
WO	WO2005041784	A2	5/2005	WO	WO2008112437	A2	9/2008
WO	WO2005044143	A1	5/2005	WO	WO2008124056	A1	10/2008
WO	WO2005051172	A2	6/2005	WO	WO2008140989	A2	11/2008
WO	WO2005055958	A2	6/2005	WO	WO2008157497	A2	12/2008
WO	WO2005065324	A2	7/2005	WO	WO2008157777	A1	12/2008
WO	WO2005065552	A2	7/2005	WO	WO2009005625	A1	1/2009

US 8,317,808 B2

Page 7

WO WO2009005634 A1 1/2009
WO WO2009011824 A1 1/2009
WO WO2009012001 A1 1/2009
WO WO2009022348 A1 2/2009
WO WO2009036094 A2 3/2009
WO WO2009039371 A1 3/2009
WO WO2009/050717 4/2009
WO WO2009042442 A1 4/2009
WO WO2009048314 A1 4/2009
WO WO2009050717 A2 4/2009
WO WO2009059005 A1 5/2009
WO WO2009064845 A2 5/2009
WO WO2009069119 A1 6/2009

WO WO2009075786 A1 6/2009
WO WO2009075932 A1 6/2009
WO WO2009075933 A1 6/2009
WO WO2009092294 A1 7/2009
WO WO2009086446 A1 7/2009
WO WO2009094015 A1 7/2009
WO WO2009097380 A1 8/2009
WO WO2009102792 A2 8/2009
WO WO2009104182 A2 8/2009
WO WO2009113972 A2 9/2009
WO WO2009126781 A1 10/2009

* cited by examiner

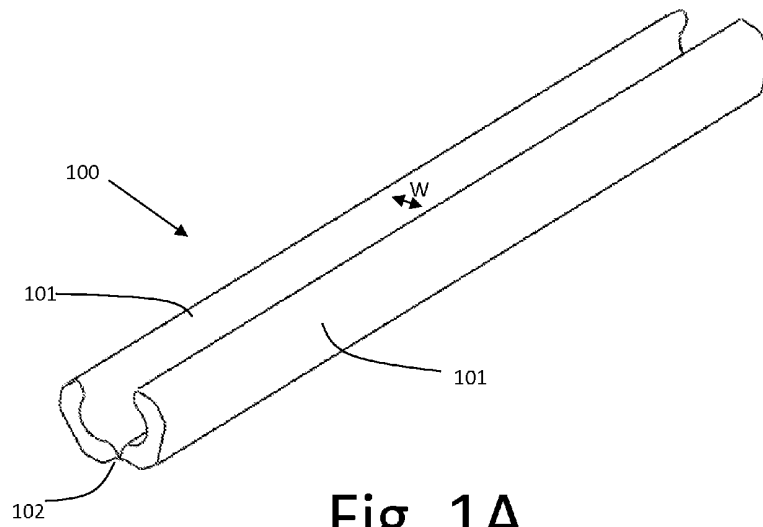

Fig. 1A

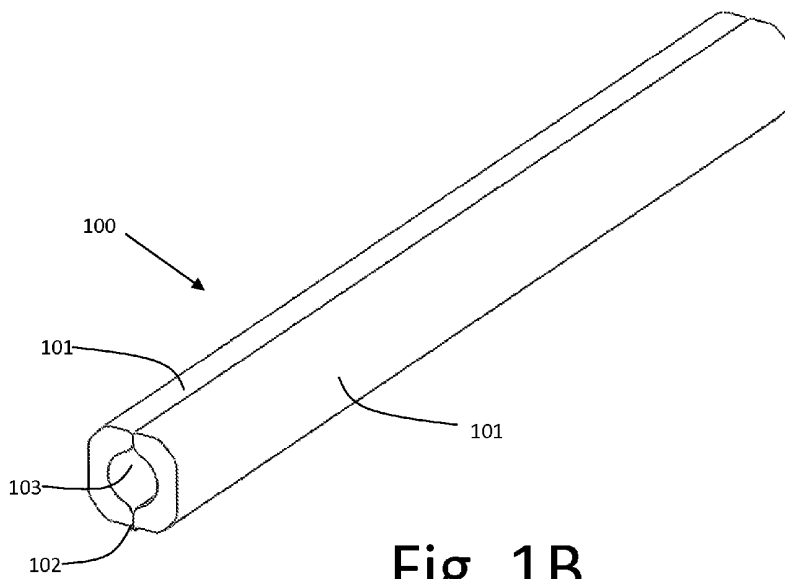

Fig. 1B

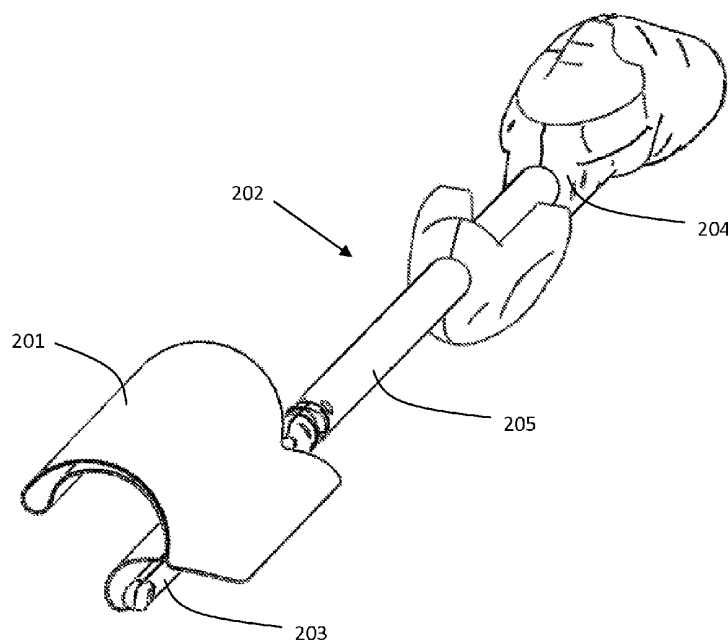

Fig. 2A

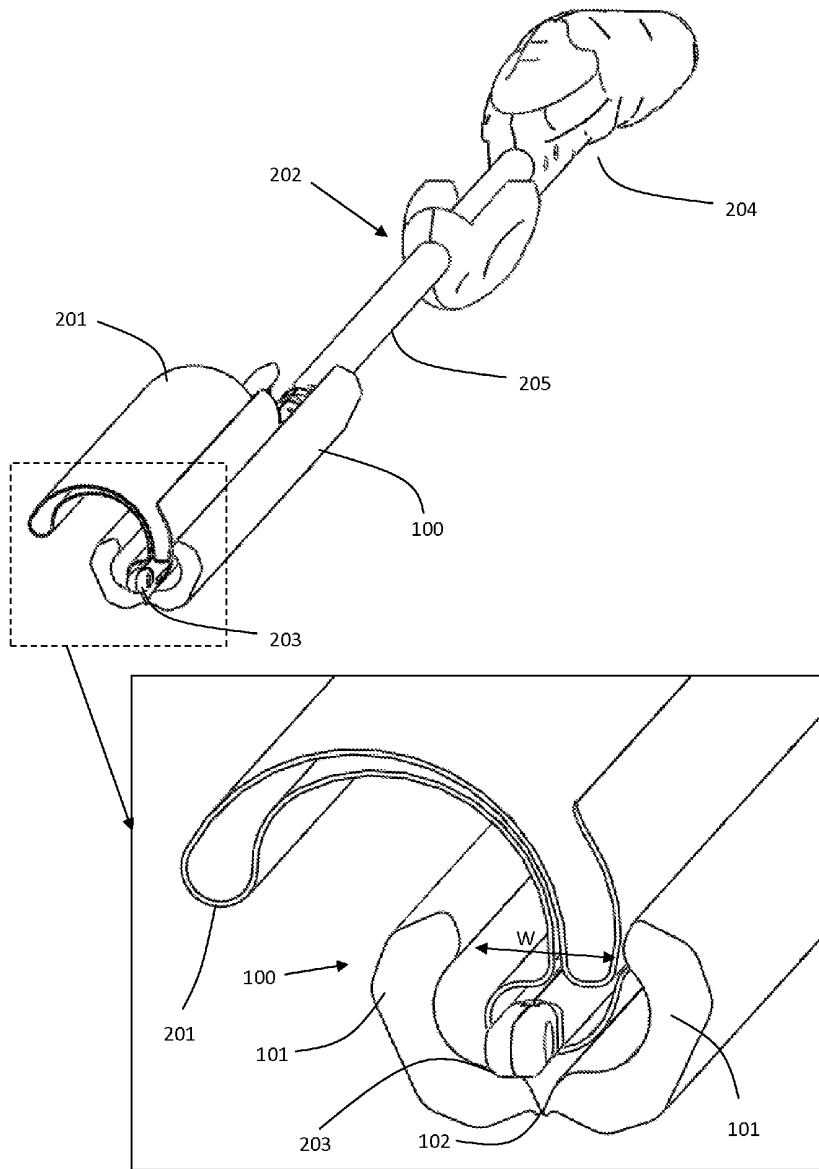

Fig. 2B

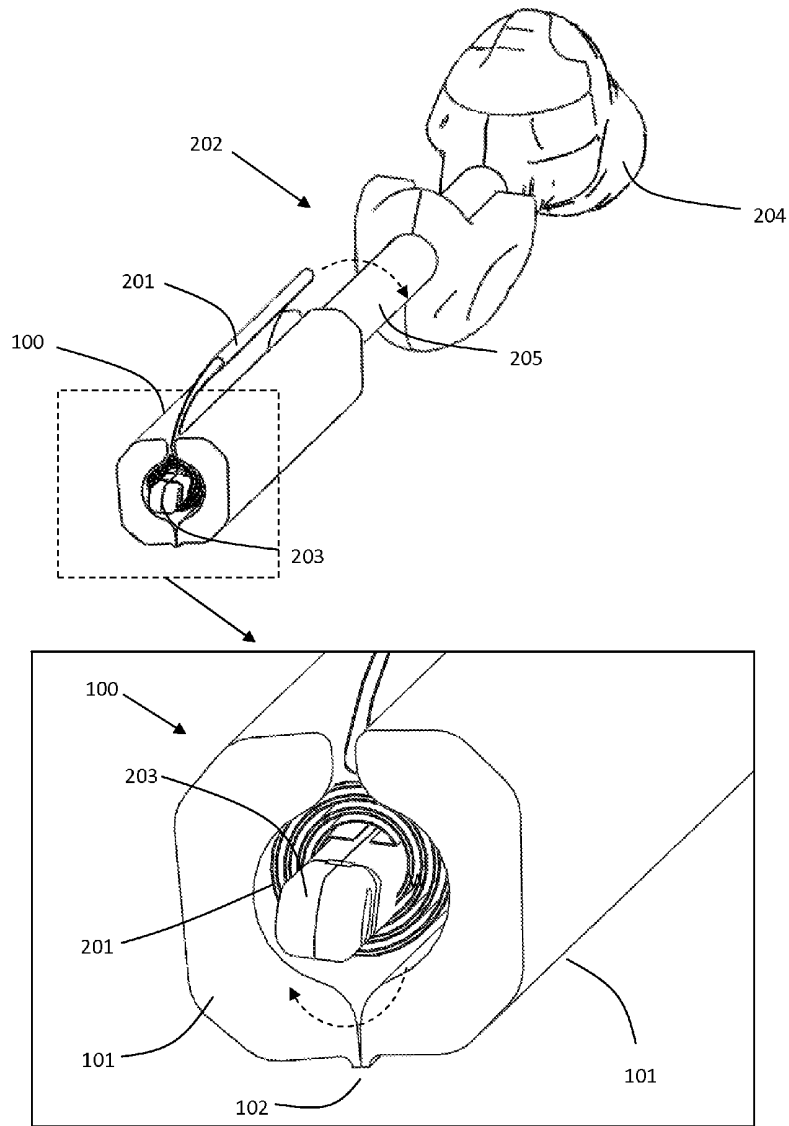

Fig. 2C

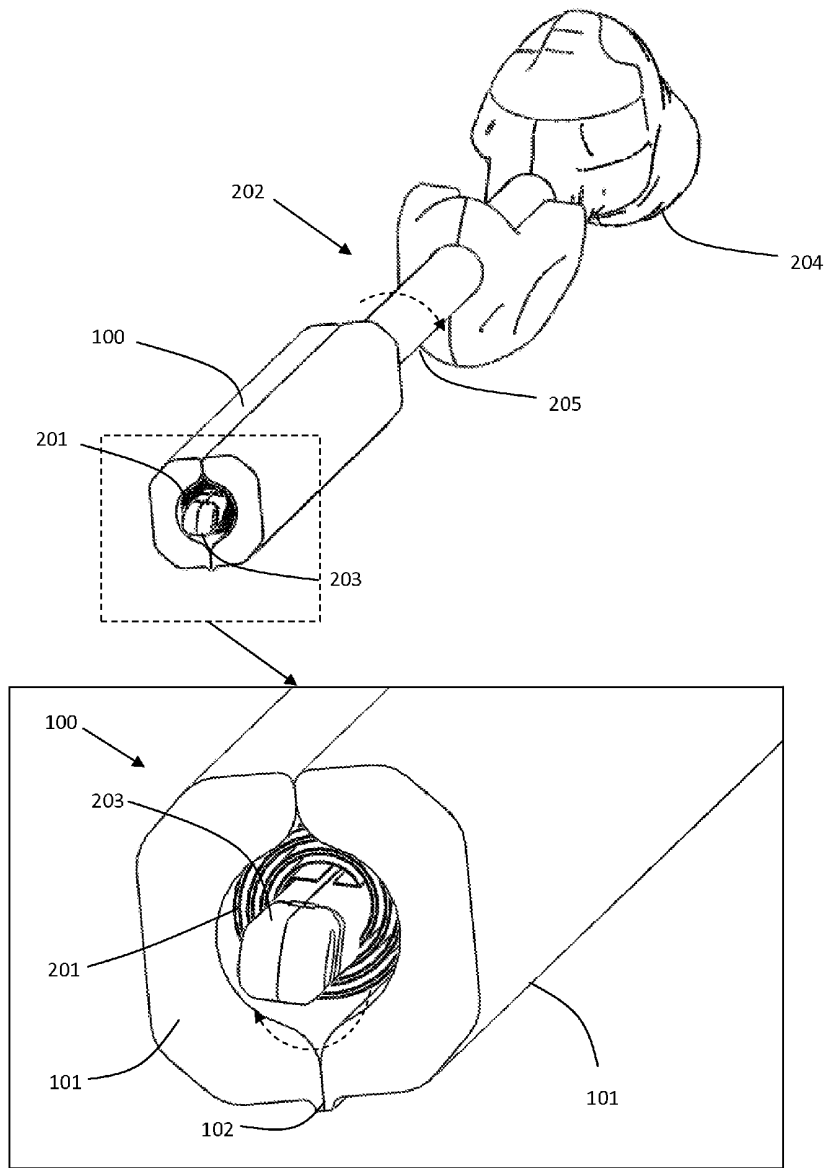

Fig. 2D

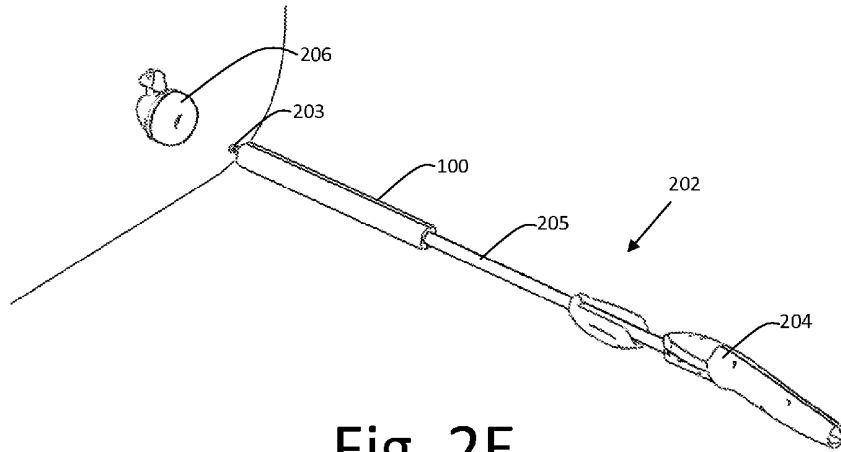

Fig. 2E

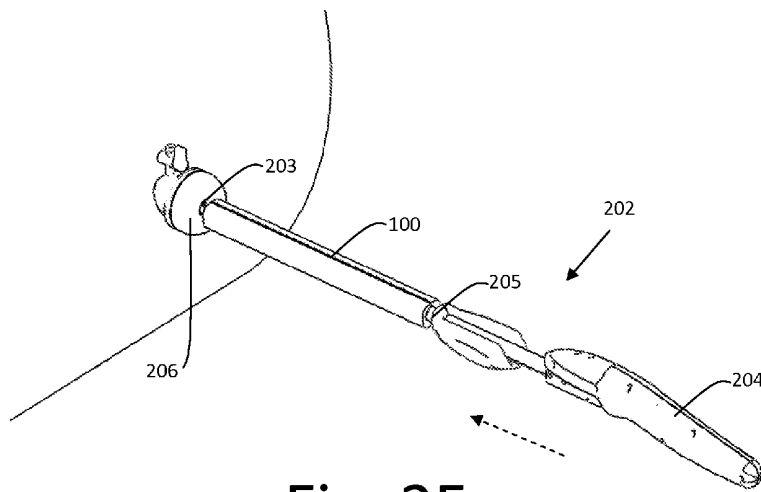
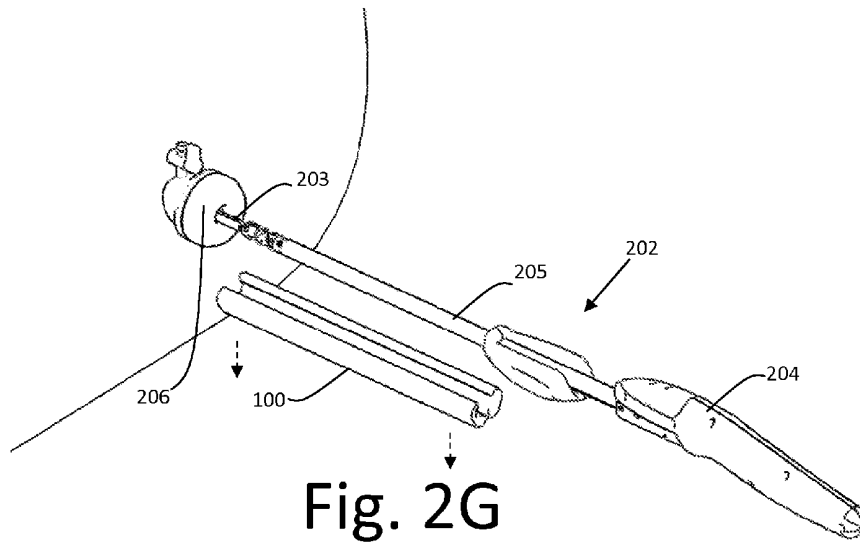

Fig. 2F



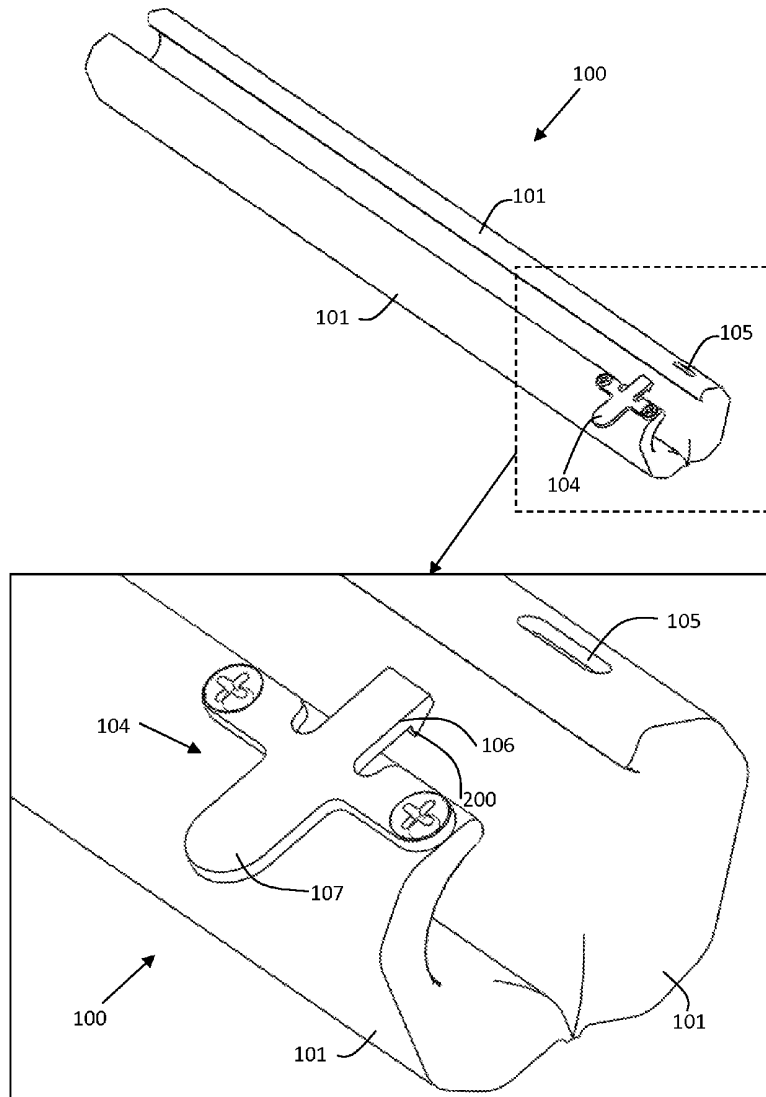

Fig. 3A

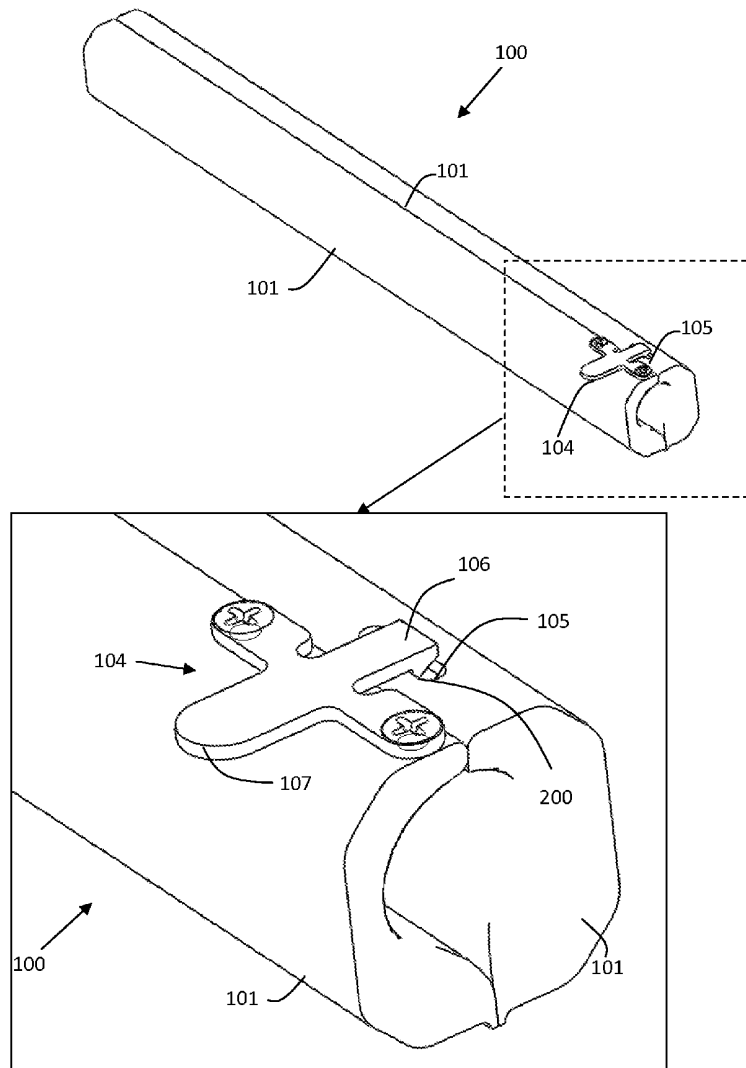

Fig. 3B

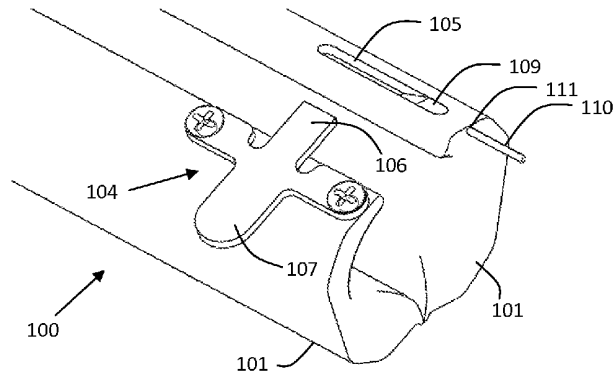

Fig. 3C

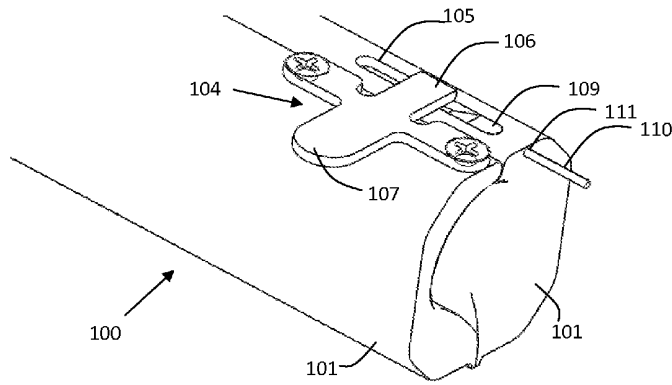

Fig. 3D

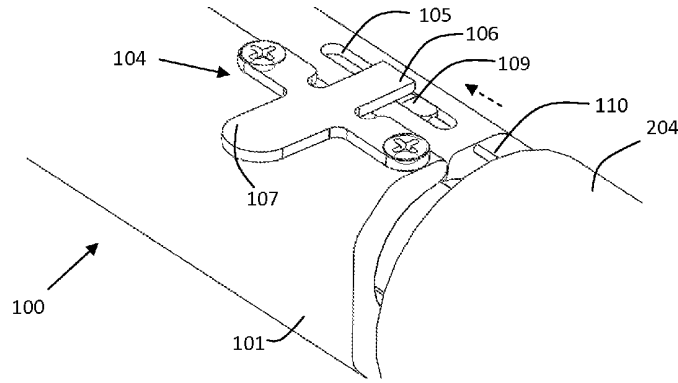

Fig. 3E

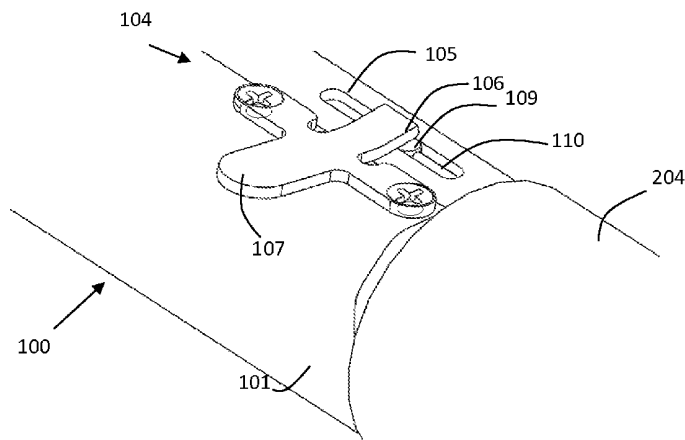

Fig. 3F

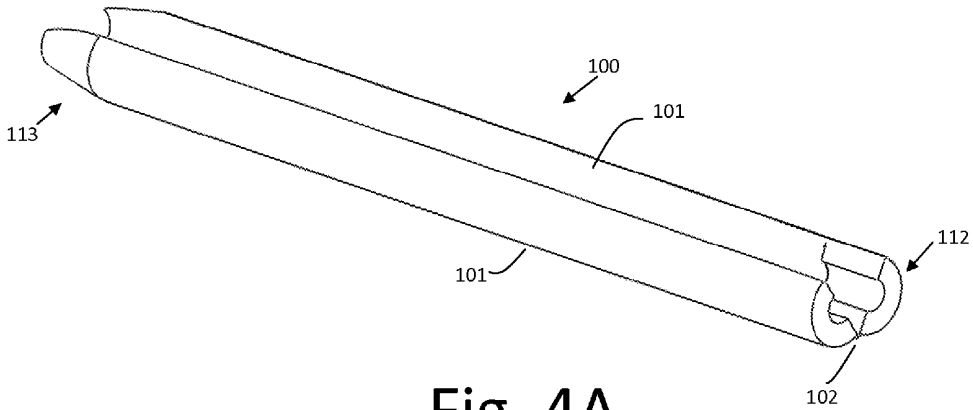

Fig. 4A

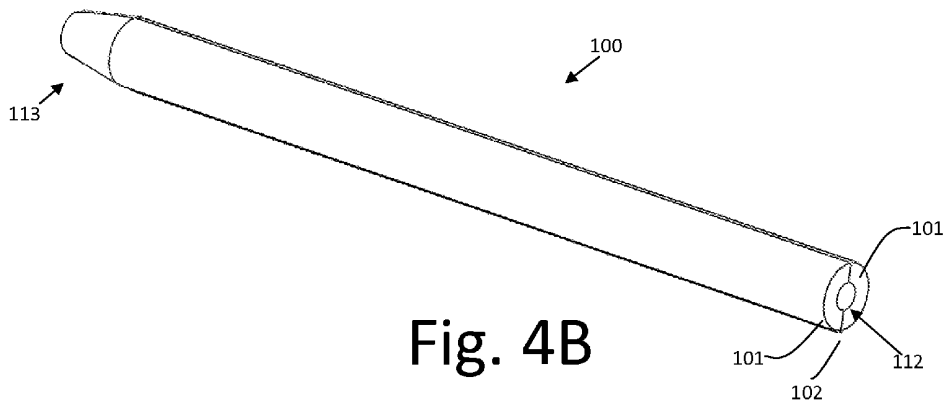

Fig. 4B

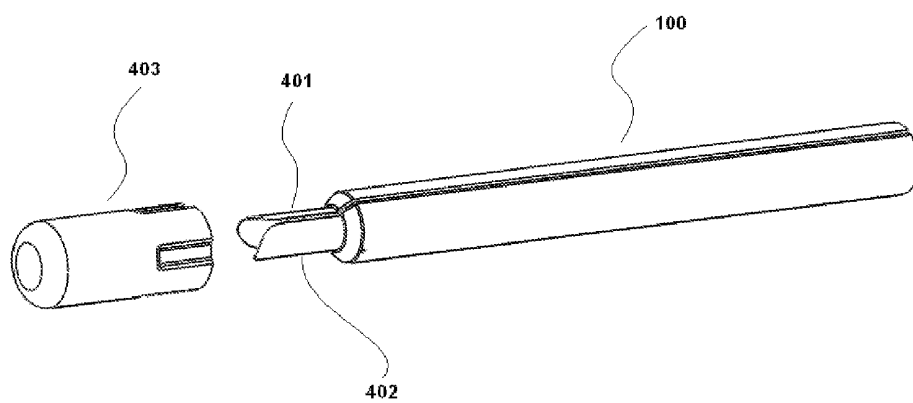

Fig. 4C

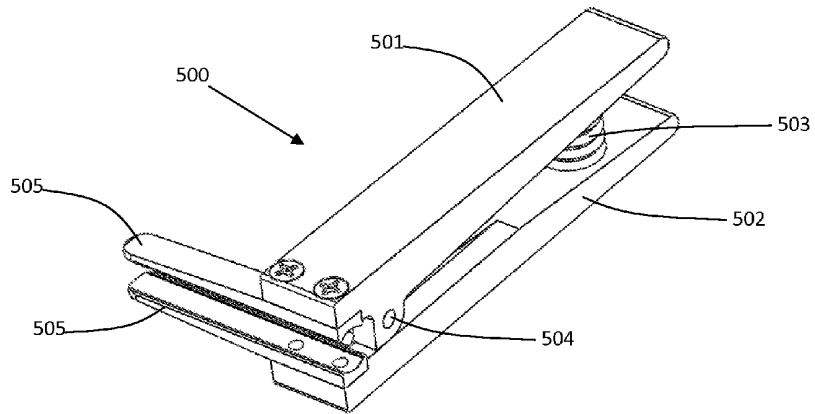

Fig. 5A

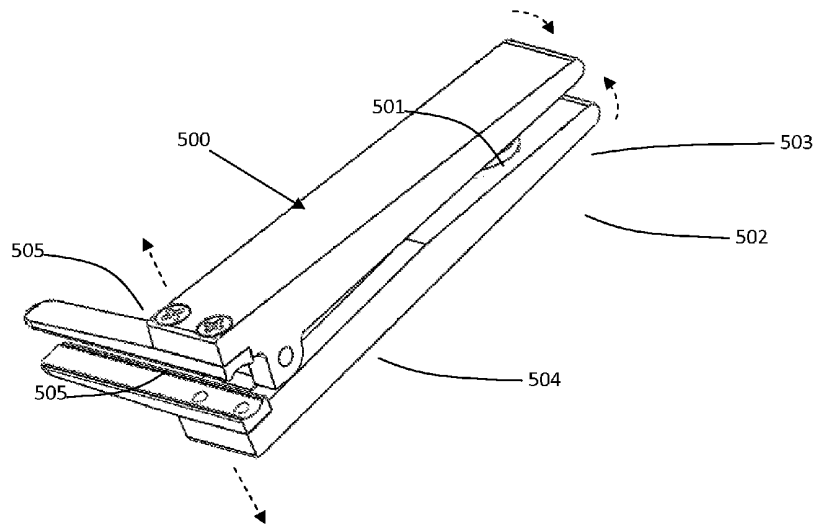
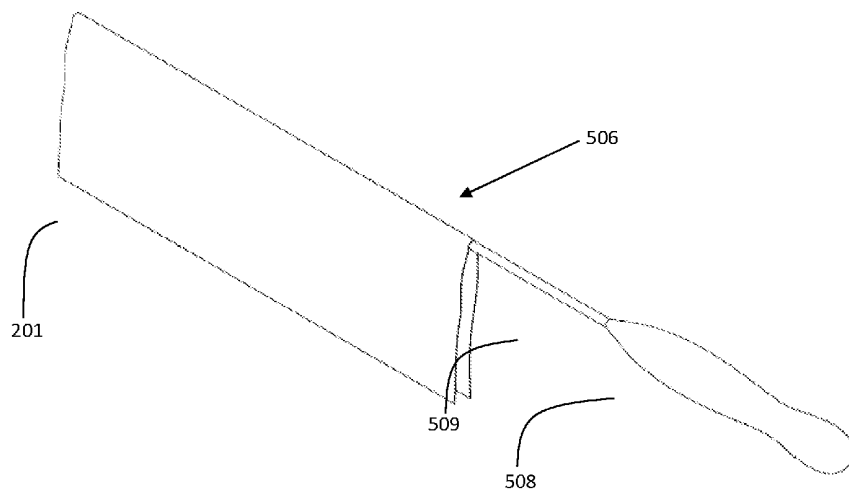
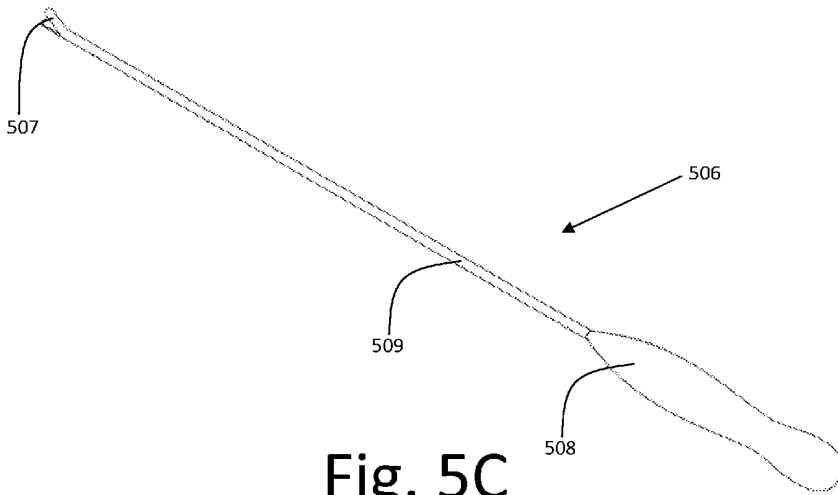

Fig. 5B



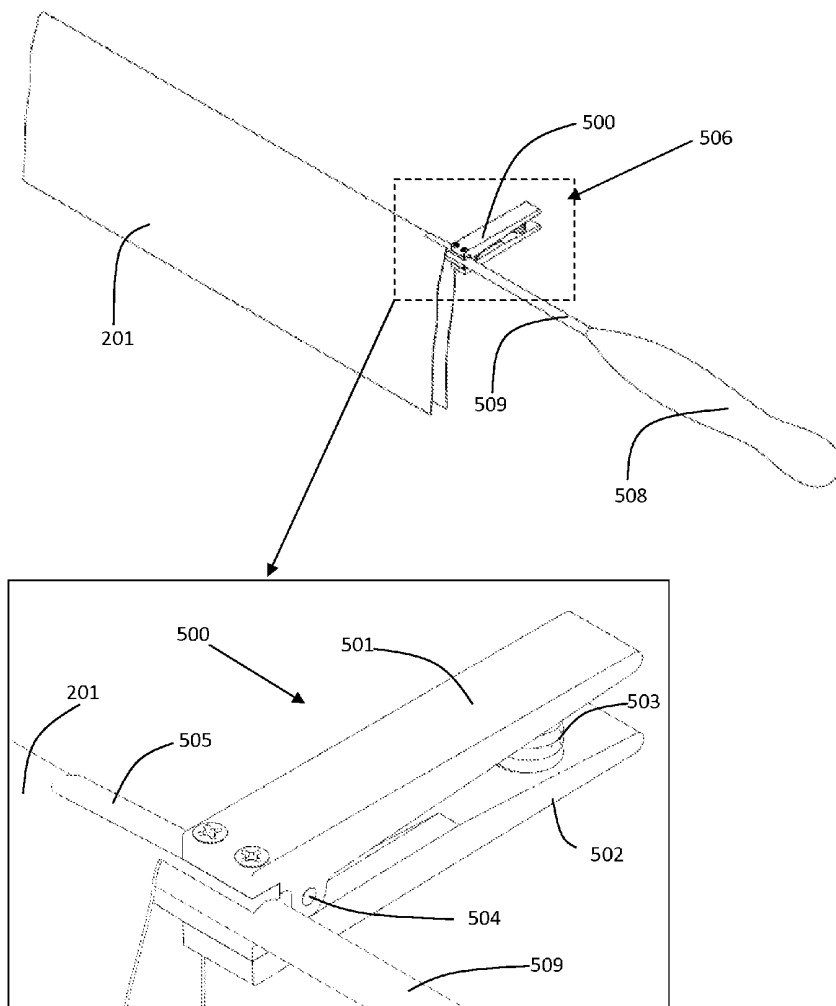

Fig. 5E

DEVICE AND METHOD FOR ROLLING AND INSERTING A PROSTHETIC PATCH INTO A BODY CAVITY

RELATED APPLICATIONS

The present application is a continuation-in-part of U.S. patent application Ser. No. 12/834,456, filed Jul. 12, 2010, which is a continuation-in-part of PCT international patent application number PCT/IL2009/000188, filed Feb. 18, 2009, which claims the benefit of and priority to U.S. provisional patent application Ser. No. 61/029,386, filed Feb. 18, 2008. The present application also claims the benefit of and priority to U.S. provisional patent application Ser. No. 61/300,455, filed Feb. 2, 2010. The content of each of these is incorporated by reference herein in its entirety.

FIELD OF THE INVENTION

This invention generally relates to minimal invasive surgery. More specifically the current invention relates to an apparatus especially adapted to fold prosthetic patches and to insert said patches into a body cavity through a cannula or an incision.

BACKGROUND OF THE INVENTION

An object of the present invention is to provide apparatus and a method for performing corrective surgery on internal wounds such as hernia where invasion of the patient's body tissues is minimized and resultant trauma is reduced.

A hernia is a protrusion of a tissue, structure, or part of an organ through the muscular tissue or the membrane by which it is normally contained. In other words a hernia is a defect in the abdominal wall through which a portion of the intra-abdominal contents can protrude. This often causes discomfort and an unsightly, visible bulge in the abdomen. When such a hernia defect occurs in the abdominal region, conventional corrective surgery has required opening the abdominal cavity by surgical incision through the major abdominal muscles. While this technique provides for effective corrective surgery of the hernia defect, it has the disadvantage of requiring a hospital stay of as much as a week, during which pain is frequently intense, and it requires an extended period of recuperation. After the conventional surgery patients frequently cannot return to a full range of activity and work schedule for a month or more. Accordingly, medical science has sought alternative techniques that are less traumatic to the patient and provide for more rapid recovery.

Laparoscopy is the science of introducing a viewing instrument through a port into a patient's body, typically the abdominal cavity, to view its contents. This technique has been used for diagnostic purposes for more than 75 years. Operative laparoscopy is performed through tiny openings in the abdominal wall called ports. In most surgical techniques several ports, frequently three to six, are used. Through one port is inserted the viewing device, which conventionally comprises a fiber optic rod or bundle having a video camera affixed to the outer end to receive and display images from inside the body. The various surgical instruments are inserted through other ports to do the surgery that normally would be performed through an open incision through the abdominal wall. Because the laparoscopic surgical techniques require only very small holes through the abdominal wall or other portions of the body, a patient undergoing such surgery may

frequently leave the hospital within one day after the surgery and resume a full range of normal activities within a few days thereafter.

In repairing hernia the physician needs to first roll the patch in order to insert the same into the abdominal cavity.

Such rolling of the patch can be a time consuming process and sometimes even a highly difficult procedure. In addition, insufficient rolling of said patch may damage the patch during its insertion and may require operation of large forces during said insertion; such forces may lead to patient injuries and/or damage to the insertion tool.

Thus, there is still a long felt need for a device that will enable a an easy rolling of the patch prior to the insertion of the same to the abdominal cavity.

SUMMARY OF THE INVENTION

It is one object of the present invention to provide a patch rolling apparatus (PRA) adapted to enable a tight and easy rolling of a prosthetic patch onto a surgical tool such that a minimum effective cross-section of said rolled prosthetic patch perpendicular to the direction of insertion, prior to, and during, said insertion into either a cannula or an opening is obtained. Exemplary surgical tools include patch deployment devices as described in U.S. patent application Ser. No. 12/834,456, the content of which is incorporated by reference herein in its entirety.

It is another object of the present invention to provide the PRA as defined above, wherein said PRA comprises at least two sections **101** hinge-like coupled together; said PRA is characterized by at least two configurations: (i) an open configuration (OC) in which said two sections are apart to create a gap **W** into which said prosthetic patch can be inserted; and, (ii) a closed configuration (CC) in which said gap is minimized or eliminated such that said PRA substantially envelopes said prosthetic patch and enables said rolling of said prosthetic patch.

It is another object of the present invention to provide the PRA as defined above, additionally comprising a locking section (LS) **104** adapted to maintain said PRA **100** in its said closed configuration.

It is another object of the present invention to provide the PRA as defined above, wherein said LS comprising a locking hook **200**, attached to at least one section **101** of said PRA **100** and a locking groove **105** located on the second section **101** of said PRA **100**.

It is another object of the present invention to provide the PRA as defined above, wherein said LS comprising and a release tab **107** adapted to allow said release of said locking; such that once said release tab **107** is pressed said PRA is transformed into said open configuration.

It is another object of the present invention to provide the PRA as defined above, wherein said LS additionally comprising an automatic release section (ARS) which automatically releases the two sections **101** of said PRA **100** once said patch **201** is at least partially inserted into said body cavity; said ARS comprising a tilted tab **109** and pin **110**.

It is another object of the present invention to provide the PRA as defined above, wherein said PRA **100** additionally comprising an anti-buckling section ABS **112** adapted to prevent buckling of said distal portion **203** of said PIS **202** during said insertion of said patch **201**.

It is another object of the present invention to provide the PRA as defined above, wherein said PRA **100** additionally comprising an insertion tip **113** adapted to enable better insertion of said PRA.

It is another object of the present invention to provide a method for rolling a prosthetic patch onto a surgical tool. The method comprising steps selected inter alia from:

- a. obtaining said prosthetic patch to be rolled on said surgical tool
- b. obtaining a patch rolling apparatus (PRA) comprising at least two sections **101** hinge-like coupled together; said PRA is characterized by at least two configurations: (i) an open configuration (OC) in which said two sections are apart to create a gap **W** into which said prosthetic patch can be inserted; and, (ii) a closed configuration (CC) in which said gap is minimized or eliminated such that said PRA substantially envelopes said prosthetic patch and enables said rolling of said prosthetic patch;
- c. configuring said PRA to be in said OC;
- d. at least partially coupling said patch to said surgical tool;
- e. inserting said surgical tool coupled to said patch into said PRA through said gap **W**;
- f. rolling said patch inside said PRA **100** while continually transforming said PRA from its said open configuration into its said closed configuration;

It is another object of the present invention to provide the method as defined above, additionally comprising step of continue rotating said patch **201** inside said PRA **100** until the entire patch **201** is rolled inside PRA **100**.

It is another object of the present invention to provide the PRA as defined above, additionally comprising step of inserting said rolled patch **201** into a body cavity through a laparoscopic cannula or through an incision.

It is another object of the present invention to provide the PRA as defined above, additionally comprising step of transforming said PRA **100** into its said open configuration and de-coupling it from said surgical tool.

It is another object of the present invention to provide the PRA as defined above, additionally comprising step of providing said PRA with a locking section (LS) **104** adapted to maintain said PRA **100** in its said closed configuration.

It is another object of the present invention to provide the PRA as defined above, additionally comprising step of providing said PRA with a release tab **107** adapted to allow said release of said locking; such that once said release tab **107** is pressed said PRA is transformed into said OC.

It is another object of the present invention to provide the PRA as defined above, additionally comprising step of providing said PRA with an automatic release section (ARS) which automatically releases the two sections **101** of said PRA **100**; said ARS comprising a tilted tab **109** and pin **110**.

It is still an object of the present invention to provide the PRA as defined above, additionally comprising step of providing said PRA with an anti-buckling section ABS **112**.

It is lastly an object of the present invention to provide the PRA as defined above, additionally comprising step of providing said PRA with an insertion tip **113**.

BRIEF DESCRIPTION OF THE DRAWINGS

The invention is herein described, by way of example only, with reference to the accompanying drawings, wherein:

FIGS. 1A-1B illustrate a preferred embodiment of the present invention.

FIGS. 2A-2G illustrate a method in which said PRA **100** is being utilized together with a patch introducing system **202** (PIS).

FIGS. 3A-3B illustrate another embodiment of the present invention in which a locking section (LS) is used.

FIGS. 3C-3F illustrate another embodiment of the present invention in which an automatic release section (ARS) is used.

FIGS. 4A-4B illustrate another embodiment of the present invention in which an anti-buckling section ABS **112** and an insertion tip **113** is used.

FIG. 4C is a perspective view of another embodiment of the present invention with a patch rolling apparatus having fins extending therefrom and a cap.

FIG. 5A is a perspective view of an embodiment of a furling clip in a first configuration.

FIG. 5B is a perspective view of the furling clip of FIG. 5A in a second configuration.

FIGS. 5C-5E illustrate a method of using the furling clip of FIG. 5A during rolling of a mesh onto a surgical instrument.

DETAIL DESCRIPTION OF THE SPECIFIC EMBODIMENTS

The following description is provided, alongside all chapters of the present invention, so as to enable any person skilled in the art to make use of the invention and sets forth the best modes contemplated by the inventor of carrying out this invention. Various modifications, however, is adapted to remain apparent to those skilled in the art, since the generic principles of the present invention have been defined specifically to provides a device and method for rolling and inserting a prosthetic patch into a body cavity.

The present invention provides a patch rolling apparatus (PRA) wherein said PRA is adapted to assist in rolling a prosthetic patch (e.g. hernia patch) onto a surgical tool (e.g. grasper, patch deployment system) such that said patch can be inserted into a body cavity (e.g. abdominal cavity) during a minimal invasive surgery.

It should be emphasized that some of the major advantages of the present invention, with respect to the prior art, is the ability roll prosthetic patches, especially large patches, faster and easier relatively to the current manual rolling manner.

Furthermore, the present invention enables an easier insertion of said patch into said body cavity relatively to the current manner.

The term "Hernia" refers hereinafter to umbilical hernia, hiatal hernia, ventral hernia, postoperative hernia, epigastric hernia, spigelian hernia, inguinal hernia and femoral hernia, generally any abdominal wall related hernia.

The term "mesh deployment system" refers hereinafter to any device adapted to deploy a mesh/patch during a hernia surgery.

The term "hinge" or "hinge-like connection" refers hereinafter as to a type of bearing that connects two solid objects, typically allowing only a limited angle of rotation between them. Two objects connected by an ideal hinge rotate relative to each other about a fixed axis of rotation (the geometrical axis of the hinge). Hinges may be made of flexible material or of moving components. The term "hinge like connection" can refer to a standard hinge or to a living hinge (i.e., a thin flexible hinge (flexure bearing) made from plastic that joins two rigid parts together while allowing them to bend along the line of the hinge).

The term "minimally invasive surgery" refers hereinafter to procedures that avoid open invasive surgery in favor of closed or local surgery with fewer traumas. Furthermore, the term refers to a procedure that is carried out by entering the body through the skin or through a body cavity or anatomical opening, but with the smallest damage possible.

The term “pressurized body cavity” refers hereinafter to a body cavity (e.g. intraperitoneal cavity) which is insufflated by gas (e.g. CO₂) during a minimal invasive surgery.

The term “closed configuration” refers hereinafter to the configuration of the PRA 100 shown in FIG. 1B.

The term “open configuration” refers hereinafter to the configuration of the PRA 100 shown in FIG. 1A.

Before explaining the figures, it should be understood that the invention is not limited in its application to the details of construction and the arrangement of the components set forth in the following description or illustrated in the drawings. The invention can be carried out in various ways.

Reference is now made to FIG. 1A-1B illustrating a preferred embodiment of the present invention. According to this embodiment a patch rolling apparatus (PRA) 100 is provided. Said PRA 100 comprises two sections 101 connected to each another via a hinge 102 such that a movement of each of said sections relatively to each other is enabled along and around said hinge 102. Hinge 102 can be either a living hinge on a conventional hinge.

Said PRA 100 is characterized by two separate configurations: an open configuration (OC), as can be seen in FIG. 1A and a closed configuration (CC), as can be seen in FIG. 1B.

In the open configuration said two sections 101 are positioned apart from each other such that a gap (W) is created between them, through which a pre-rolled patch can be at least partially inserted and encapsulated within said two sections 101.

In the closed configuration said two portions 101 are substantially adjacent to one another, creating an internal cavity 103. In a preferred embodiment said cavity 103 contains no sharp edges so as to prevent any damage that may be caused to the patch during said rolling operation.

Reference is now being made to FIGS. 2A-2G illustrating a method in which said PRA 100 is utilized together with a patch introducing system 202 (PIS) in order to roll and insert a patch 201 into a body cavity of a patient during a surgery (e.g. laparoscopic hernia repair surgery).

PIS 202 is define as a surgical tool intended to insert a patch into the abdominal cavity, e.g. a patch deployment system (as illustrated in FIGS. 2A-2G), a patch introducer, a laparoscopic grasper or any combination thereof.

PIS 202 comprises a distal portion 203 (on which said patch 201 is rolled), proximal portion 204 (which is held by the surgeon) and a shaft 205 connecting said proximal portion 204 and distal portion 203 together.

The method comprises steps selected inter alia from:

1. Obtaining a patch 201 and a PIS 202.
2. Attaching said patch 201 to said distal portion of said PIS 202 (FIG. 2A).
3. Obtaining PRA 100 in its said open configuration.
4. Inserting said distal portion 203 of said PIS 202 and at least a portion of said patch 201 into said PRA 100 through said gap W (FIG. 2B).
5. Rotating (rolling) said distal portion 203 and said patch 201 inside said PRA 100 while continually transforming said PRA from its said open configuration into its said closed configuration (FIG. 2C).
6. Continue rotating said distal portion 203 and said patch 201 inside said PRA 100 until the entire patch 201 in rolled inside PRA 100 (FIG. 2D).
7. Inserting said rolled patch 201 into a body cavity (e.g. abdominal cavity) through a laparoscopic cannula 206 or through an incision (FIG. 2E-2F).
8. Transforming said PRA 100 into its said open configuration and de-coupling it from said PIS 202 (FIG. 2G).

It should be mentioned that during said insertion of said patch into said body cavity, the distal portion can be subjected to large forces and therefore may be buckle or deformed.

in order to prevent such deformation, said PRA 100 additionally provides external support in order to prevent said buckling or deformation.

It also should be mentioned that said PRA 100 holds said patch 201 tightly rolled during said insertion to said body cavity. As a result said insertion is made with less resistance and therefore is faster and safer compare to manual insertion.

Reference is now being made to FIGS. 3A-3B which describe another embodiment of the present invention. According the this embodiment, said PRA 100 additionally comprises locking section (LS) 104 which is adapted to hold said PRA 100 in its said closed configuration.

Additionally said LS 104 allows the surgeon to release said locking when desired. According to this embodiment, said LS 104 comprises a locking hook 200, attached to one section 101 of said PRA 100 and a locking groove 105 located on the outer surface of the second section 101 of said PRA 100.

Said locking hook 200 comprises a locking tab 106, adapted to be hinged inside said groove 105 and a release tab 107, adapted to allow said release of said locking.

FIG. 3A describes said PRA 100 in its said open configuration; as can be seen from this figure, in the open configuration said locking tab 106 is not hinged inside said groove 105, therefore a free motion of said two sections 101 is enabled.

Once the said PRA 100 in transformed into its said close configuration, said locking tab 106 is inserted into said groove 105; and, therefore holding the two sections 101 together (see FIG. 3B). In order to reopen said PRA 100, the surgeon presses the release tab 107 of said LS 104 therefore elevating said hook tab out of said groove 105 and releasing the two sections 101 from one another.

Reference is now being made to FIGS. 3C-3F which illustrate another embodiment of the present invention. According to this embodiment, said LS 104 additionally comprises an automatic release section (ARS) which automatically releases the two sections 101 of said PRA 100 once said patch 201 is at least partially inserted into said body cavity.

Said ARS comprises a tab 109 and a pin 110. Said tab 109 has a tilted end and is initially located at the proximal end (relative to the surgeon) of said groove 105. Said pin 110 in located inside a hole 111 at section 101.

Once said PRA 100 is transformed into its said closed configuration said locking hook 110 is inserted into said groove 105 (see FIG. 3D).

Once said rolled patch is at least partially inserted into said body cavity, the proximal portion 204 of said PIS 202 pushes said pin 110 and said tab 109 toward the distal end of said groove 105.

As a result tab 109 is pushing said locking tab 106 out of said groove and therefore releasing the two sections 101 (see FIGS. 3E and 3F).

Reference is now being made to FIGS. 4A-4B which illustrate another embodiment of the present invention. According to this embodiment, said PRA 100 additionally comprises an anti-buckling section ABS 112 and an insertion tip 113.

Said ABS 112 is characterized by having a smaller inner diameter than the rest of said PRA 100. Said ABS 112 is adapted to tightly envelope the shaft of said PIS 202 such that lateral movement between said distal portion 203 of said PIS 202 and said shaft of said PIS is limited and therefore the risk that the distal portion of said PIS will buckle is reduced.

Said insertion tip 113 is characterized by having a conical shape and is adapted to assist inserting said rolled patch 201 into said body cavity through an incision. Once said patch is

completely rolled inside said PRA the surgeon can at least partially insert said insertion tip **113** into said incision, therefore said rolled patch is substantially centered in relation to said incision during the initial stage of said insertion; in addition, said insertion tip **113** opens said incision and allowing an easier insertion of said patch into said body cavity through said incision.

Reference is now made to FIG. **4C** which illustrate another embodiment of the present invention. According to this embodiment, said PRA **100** additionally comprises insertion fins **401** and **402**. These fins are adapted to allow a better insertion of a mesh through a port or an incision by opening the valve (in the case of a port) or the subcutaneous layer (in a case on an incision). This spreading is important since sometimes the port's valve or the tissue may drag the furled mesh backward along the shaft of the instrument during the insertion process, thus increasing its overall cross section and interfering with the insertion process. Spreading of the valve or the tissue reduces the overall friction, therefore allowing better insertion. The fins may be covered by a cap **403**.

FIG. **5A-5E** illustrate an embodiment of a furling clip (FC) **500**. Said FC **500** is adapted to assist in rolling a prosthetic mesh around a surgical instrument (e.g. Grasper, mesh deployment device) by securing said patch to the shaft of said surgical instrument during said rolling. Said FC **500** is removed once such rolling is at least partially obtained.

In a preferred embodiment, described in FIG. **5A-5B**, said FC **500** comprises two sections **501** and **502** which are connected via a hinge **504**. A spring **503** is placed between sections **501** and **502** in order to provide clamping force. A clamping edge **505** is located at the distal end of each section **501** and **502**, said clamping edge **505** is adapted to hold said mesh and said shaft of said instrument, while allowing the mesh to be rolled only around them and not around the sections **501** & **502**; therefore allowing better rolling of the mesh around the shaft and enabling the removal of said FC **500** from said shaft once said rolling is accomplished. Once the proximal end of each section **501** and **502** is squeezed, the two clamping edges are distanced from one another, hence, allowing to locate said FC **500** on said shaft (FIG. **5B**). once the pressure is removed spring **503** clamp said FC **500** on said mesh and shaft.

FIGS. **5C-5E** describes a method of using FC **500** during rolling of a mesh **201** on a surgical instrument **509**. In this case the instrument is a standard grasper which comprises a handle **508**, a shaft **509** and a forceps **507** (FIG. **5C**). During the operation, the surgeon places a mesh **201** on top of the shaft **509** and secures it by forceps **507** (FIG. **5D**). In order to prevent slipping of the rear portion of the mesh, and in order to facilitate tight and even rolling of the mesh **201** around the shaft **509**, the surgeon places a FC **500** at the proximal edge of the mesh **201** (FIG. **5E**). Said clamping edges **505** of said edge are protrude beyond the edge of each section **501** and **502**, enabling the surgeon to roll the mesh around them. The rolling can be made either manually or by a patch rolling apparatus. Once said patch **201** is substantially rolled, said FC **500** is removed from the shaft **509** by squishing sections **501** & **502** and pulling FC **500** back, then the mesh **201** is inserted to the abdominal cavity.

Incorporation By Reference

References and citations to other documents, such as patents, patent applications, patent publications, journals, books, papers, web contents, have been made throughout this disclosure. All such documents are hereby incorporated herein by reference in their entirety for all purposes.

Equivalents

The invention may be embodied in other specific forms without departing from the spirit or essential characteristics thereof. The foregoing embodiments are therefore to be considered in all respects illustrative rather than limiting on the invention described herein. Scope of the invention is thus indicated by the appended claims rather than by the foregoing description, and all changes which come within the meaning and range of equivalency of the claims are therefore intended to be embraced therein.

What is claimed is:

1. A device for facilitating rolling of a surgical mesh onto a surgical instrument, the device comprising:

a sleeve having a slit along a length of the sleeve, wherein the sleeve comprises portions movable to an open configuration for operably coupling with an unrolled mesh on a surgical instrument, and a closed configuration for facilitating rolling of the mesh onto the instrument; and a plurality of rigid members connected to a distal end of the sleeve, the rigid members are adapted to open valves of surgical ports.

2. The device according to claim **1**, portions of the sleeve comprises:

a first portion; and

a second portion, wherein the first and second portion are hingedly connected.

3. The device according to claim **1**, further comprising a locking mechanism for locking the sleeve when it is in the closed configuration.

4. The device according to claim **3**, wherein the locking mechanism further comprises a member that provides for automatic release of the locked sleeve once the mesh is at least partially inserted into a body cavity.

5. The device according to claim **1**, further comprising an insertion tip.

6. The device of claim **1**, wherein the rigid members are fins.

7. The device according to claim **1**, wherein the fins are adapted to cause spreading of a subcutaneous layer of tissue.

8. The device according to claim **1**, wherein the mesh is a patch.

9. The device according to claim **8**, wherein the instrument is a patch deployment apparatus or a laparoscopic grasper.

10. The device according to claim **1**, further comprising a member at a distal portion of the sleeve that prevents bucking of a shaft of a patch deployment apparatus or a laparoscopic grasper.

11. A method for facilitating rolling of a mesh onto a surgical instrument, the method comprising:

operably coupling a device that facilitates rolling of an unrolled mesh on a surgical instrument, wherein the device comprises a sleeve having a slit along a length of the sleeve, wherein the sleeve has an open configuration for operably coupling with an unrolled mesh on a surgical instrument, and a closed configuration for facilitating rolling of the mesh onto the instrument, wherein the sleeve further comprises a plurality of rigid members connected to a distal end of the sleeve;

using the device to thereby roll the mesh on the instrument; and

advancing the instrument such that the rigid members of the sleeve spread apart subcutaneous tissue, thereby allowing advancement of the instrument having the rolled mesh into a patient.

12. The method according to claim **11**, further comprising prior to the coupling step, placing the unrolled mesh onto the surgical instrument.

9

13. The method according to claim 12, further comprising prior to the coupling step, attaching the unrolled mesh to the instrument via a clip.

14. The method according to claim 11, wherein the mesh is a patch.

15. The method according to claim 14, wherein the instrument is a patch deployment apparatus.

16. A method for facilitating rolling of a mesh onto a surgical instrument, the method comprising:

operably coupling a device that facilitates rolling of an unrolled mesh on a surgical instrument, wherein the device comprises a sleeve having a slit along a length of the sleeve, wherein the sleeve has an open configuration

10

for operably coupling with an unrolled mesh on a surgical instrument, and a closed configuration for facilitating rolling of the mesh onto the instrument, wherein the sleeve further comprises a plurality of rigid members connected to a distal end of the sleeve; using the device to thereby roll the mesh on the instrument; and advancing the instrument such that the rigid members of the sleeve open a closed of a surgical port, thereby allowing advancement of the instrument having the rolled mesh into a patient.

* * * * *

专利名称(译)	用于将假体贴片卷入和插入体腔的装置和方法		
公开(公告)号	US8317808	公开(公告)日	2012-11-27
申请号	US12/889774	申请日	2010-09-24
[标]申请(专利权)人(译)	POLYTOUCH医疗		
申请(专利权)人(译)	POLYTOUCH MEDICAL , INC.		
当前申请(专利权)人(译)	COVIDIEN LP		
[标]发明人	LEVIN OFEK LEVY ARIE		
发明人	LEVIN, OFEK LEVY, ARIE		
IPC分类号	A61B17/08 A61F2/02		
CPC分类号	A61B17/00234 A61F2/0063 A61B2017/0053 A61F2002/0072 Y10T29/53		
优先权	61/029386 2008-02-18 US 61/300455 2010-02-02 US		
其他公开文献	US20110034942A1		
外部链接	Espacenet USPTO		

摘要(译)

本发明一般涉及微创手术。更具体地，本发明涉及一种特别适于折叠假体贴片并通过套管或切口将所述贴片插入体腔的装置。

