



US007481765B2

(12) **United States Patent**
Ewers et al.

(10) **Patent No.:** **US 7,481,765 B2**
(45) **Date of Patent:** **Jan. 27, 2009**

(54) **SURGICAL ACCESS APPARATUS AND METHOD**

(75) Inventors: **Richard C. Ewers**, Fullerton, CA (US); **John R. Brustad**, Dana Point, CA (US); **Edward D. Pingleton**, Laguna Niguel, CA (US); **Nabil Hilal**, Laguna Niguel, CA (US); **Gary R. Dulak**, Newport Beach, CA (US); **Payam Adlparvar**, Lake Forest, CA (US); **Robert R. Bowes**, Aliso Viejo, CA (US)

(73) Assignee: **Applied Medical Resources Corporation**, Rancho Santa Margarita, CA (US)

(*) Notice: Subject to any disclaimer, the term of this patent is extended or adjusted under 35 U.S.C. 154(b) by 26 days.

(21) Appl. No.: **11/244,647**

(22) Filed: **Oct. 5, 2005**

(65) **Prior Publication Data**

US 2006/0030755 A1 Feb. 9, 2006

Related U.S. Application Data

(63) Continuation of application No. 10/381,220, filed on Mar. 20, 2003.

(51) **Int. Cl.**
A61B 1/32 (2006.01)

(52) **U.S. Cl.** **600/208**

(58) **Field of Classification Search** 606/1, 606/191, 108, 213; 604/164.04, 288.02, 604/288.03; 600/206, 208

See application file for complete search history.

(56) **References Cited**

U.S. PATENT DOCUMENTS

558,364 A 4/1896 Doolittle
(Continued)

FOREIGN PATENT DOCUMENTS

EP 1 125 552 8/2001
(Continued)

OTHER PUBLICATIONS

International Search Report and Written Opinion of the International Searching Authority for PCT application No. PCT/US01/29682.

(Continued)

Primary Examiner—Todd E Manahan

Assistant Examiner—Tuan V Nguyen

(74) *Attorney, Agent, or Firm*—Pui Tong Ho; David G. Majdali

(57) **ABSTRACT**

A surgical access device includes a single valve forming a seal with the body wall and providing an access channel into a body cavity. The valve has properties for creating a zero-seal in the absence of an instrument and an instrument seal with instruments. The valve can include a gel comprised of an elastomer and oil providing elongation greater than 1000 percent and durometer less than 5 Shore A. The single valve can be used as a hand port where the instrument comprises the arm of a surgeon. A method for making the surgical access device includes combining a gelling agent with oil, preferably in a molding process. A method for using the device includes creating an opening with the instrument. An organ can be removed from the body cavity through the single valve to create an organ seal while the organ is addressed externally of the body cavity.

30 Claims, 18 Drawing Sheets

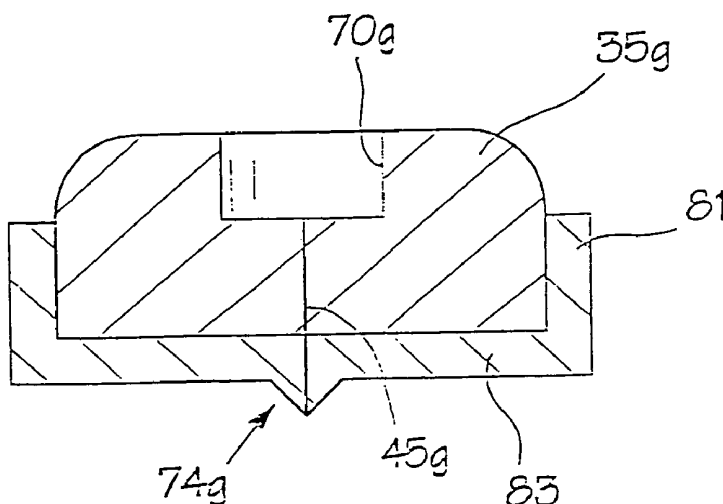

U.S. PATENT DOCUMENTS				
		5,336,708 A	8/1994	Chen
		5,350,364 A	9/1994	Stephens
		5,353,786 A	10/1994	Wilk
1,157,202 A	10/1915	5,366,478 A	11/1994	Brinkerhoff et al. 660/213
1,810,466 A	6/1931	5,368,545 A	11/1994	Schaller et al. 600/37
2,305,289 A	12/1942	5,380,288 A	1/1995	Hart et al.
2,478,586 A	8/1949	5,389,080 A	2/1995	Yoon
2,812,758 A	11/1957	5,389,081 A	2/1995	Castro
2,835,253 A	5/1958	5,407,433 A	4/1995	Loomas
2,853,075 A	9/1958	5,429,609 A	7/1995	Yoon
3,039,468 A	6/1962	5,437,683 A	8/1995	Neumann et al.
3,111,943 A	11/1963	5,441,486 A	8/1995	Yoon
3,195,934 A	7/1965	5,456,284 A	10/1995	Ryan et al.
3,244,169 A	4/1966	5,460,616 A	10/1995	Weinstein
3,332,417 A	7/1967	5,476,475 A	12/1995	Gadberry
3,347,226 A	10/1967	5,480,410 A	1/1996	Cuschieri et al. 606/213
3,347,227 A	10/1967	5,486,426 A	1/1996	McGee et al.
3,397,692 A	8/1968	5,492,304 A	2/1996	Smith
3,402,710 A	9/1968	5,496,280 A	3/1996	Vandenbroek
3,416,520 A	12/1968	5,503,112 A	4/1996	Luhman et al.
3,447,533 A	6/1969	5,508,334 A	4/1996	Chen
3,523,534 A	8/1970	5,514,133 A	5/1996	Golub et al. 606/1
3,717,151 A	2/1973	5,518,278 A	5/1996	Sampson
3,831,583 A	8/1974	5,522,791 A	6/1996	Leyva
3,841,332 A	10/1974	5,524,644 A	6/1996	Crook 128/888
3,850,172 A	11/1974	5,531,758 A	7/1996	Uschold et al.
3,856,021 A	12/1974	5,545,179 A	8/1996	Williamson, IV 606/213
3,860,274 A	1/1975	5,562,677 A	10/1996	Hildwein et al.
4,024,872 A	5/1977	5,603,702 A	2/1997	Smith
4,043,328 A	8/1977	5,628,732 A	5/1997	Antoon, Jr.
4,069,913 A	1/1978	5,632,284 A	5/1997	Graether
4,083,370 A	4/1978	5,634,911 A	6/1997	Hermann et al. 604/256
4,188,945 A	2/1980	5,634,936 A	6/1997	Linden et al. 606/213
4,217,664 A	8/1980	5,634,937 A	6/1997	Mollenaue et al. 606/213
4,222,126 A	9/1980	5,636,645 A	6/1997	Ou 128/898
4,254,973 A	3/1981	5,640,977 A	6/1997	Leahy et al. 128/897
4,338,937 A	7/1982	5,649,550 A	7/1997	Crook
4,367,728 A	1/1983	5,653,705 A	8/1997	de la Torre et al.
4,369,284 A	1/1983	5,672,168 A	9/1997	de la Torre et al. 106/1
4,454,873 A	6/1984	5,681,341 A	10/1997	Lunsford et al.
4,475,548 A	10/1984	5,709,664 A	1/1998	Vandenbroek
4,550,713 A	11/1985	5,720,730 A	2/1998	Blake, III
4,553,537 A	11/1985	5,728,103 A	3/1998	Picha et al.
4,691,942 A	9/1987	5,741,298 A	4/1998	MacLeod
4,714,749 A	12/1987	5,753,150 A	5/1998	Martin et al.
4,755,170 A	7/1988	5,760,117 A	6/1998	Chen
4,777,943 A	10/1988	5,782,817 A	7/1998	Franzel
4,798,594 A	1/1989	5,788,676 A	8/1998	Yoon
4,802,694 A	2/1989	5,792,119 A	8/1998	Marx
4,842,931 A	6/1989	5,795,290 A	8/1998	Bridges 600/210
4,856,502 A	8/1989	5,803,919 A	9/1998	Hart et al.
4,863,438 A	9/1989	5,803,921 A	9/1998	Bonadio 606/1
4,889,107 A	12/1989	5,803,923 A	9/1998	Singh-Derewa et al.
4,895,565 A	1/1990	5,810,721 A	9/1998	Mueller et al.
4,903,710 A	2/1990	5,813,409 A	9/1998	Leahy et al. 128/897
4,911,974 A	3/1990	5,814,026 A	9/1998	Yoon
4,926,882 A	5/1990	5,832,925 A	11/1998	Rothrum
4,950,223 A	8/1990	5,841,298 A	11/1998	Huang
4,984,564 A	1/1991	5,853,395 A	12/1998	Crook et al. 60/174
4,991,593 A	2/1991	5,865,729 A	2/1999	Meehan et al.
4,998,538 A	3/1991	5,865,807 A	2/1999	Blake, III
5,009,224 A	4/1991	5,871,474 A	2/1999	Hermann et al.
5,015,228 A	5/1991	5,895,377 A	4/1999	Smith
5,037,379 A	8/1991	5,899,208 A	5/1999	Bonadio 128/897
5,082,005 A	1/1992	5,904,703 A	5/1999	Gilson 606/213
5,159,921 A	11/1992	5,906,577 A	5/1999	Beane et al. 600/207
5,178,162 A	1/1993	5,919,476 A	7/1999	Fischer et al.
5,192,301 A	3/1993	5,947,922 A	9/1999	MacLeod 604/27
5,207,656 A	5/1993	5,951,588 A	9/1999	Moening
5,213,114 A	5/1993	5,957,888 A	9/1999	Hinchliffe 604/117
5,259,366 A	11/1993	5,957,913 A	9/1999	de la Torre
5,262,468 A	11/1993	5,962,572 A	10/1999	Chen 524/474
5,299,582 A	4/1994	5,964,781 A	10/1999	Mollenaue et al. 606/213
5,316,541 A	5/1994			

5,989,233	A	11/1999	Yoon	2004/0054353	A1	3/2004	Taylor
5,989,266	A	11/1999	Foster	2004/0073090	A1	4/2004	Butler et al.
5,993,471	A	11/1999	Riza	2004/0092796	A1	5/2004	Butler et al.
5,993,485	A	11/1999	Beckers	2004/0106942	A1	6/2004	Taylor et al.
5,997,515	A	12/1999	de la Torre et al. 604/256	2004/0127772	A1	7/2004	Ewers et al.
6,010,494	A	1/2000	Schafer	2004/0154624	A1	8/2004	Bonadio et al.
6,024,736	A	2/2000	de la Torre et al. 606/1	2004/0167559	A1	8/2004	Taylor et al.
6,025,067	A	2/2000	Fay	2004/0173218	A1	9/2004	Yamada et al.
6,033,426	A	3/2000	Kaji 606/213	2004/0254426	A1	12/2004	Wenchell
6,033,428	A	3/2000	Sardella 606/213	2004/0267096	A1	12/2004	Caldwell et al.
6,035,559	A	3/2000	Freed et al.	2005/0020884	A1	1/2005	Hart et al.
6,045,535	A	4/2000	Ben Nun	2005/0033246	A1	2/2005	Ahlberg et al.
6,053,934	A	4/2000	Andrews et al.	2005/0059865	A1	3/2005	Kahle et al.
6,077,288	A	6/2000	Shimomura et al.	2005/0090717	A1	4/2005	Bonadio et al.
6,142,935	A	11/2000	Flom et al.	2005/0148823	A1	7/2005	Vaugh et al.
6,142,936	A	11/2000	Beane et al.	2005/0155611	A1	7/2005	Vaugh et al.
6,149,642	A	11/2000	Gerhart et al.	2005/0197537	A1	9/2005	Bonadio et al.
6,150,608	A	11/2000	Wambeke et al. 174/652	2005/0222582	A1	10/2005	Wenchell
6,162,172	A	12/2000	Cosgrove et al. 600/208	2005/0241647	A1	11/2005	Nguyen et al.
6,224,612	B1	5/2001	Bates et al.	2005/0261720	A1	11/2005	Caldwell et al.
6,238,373	B1*	5/2001	de la Torre et al. 604/256	2005/0267419	A1	12/2005	Smith
6,254,533	B1	7/2001	Fadem et al.	2005/0283050	A1	12/2005	Gundlappalii et al.
6,254,534	B1*	7/2001	Butler et al. 600/208	2005/0288558	A1	12/2005	Ewers et al.
6,276,661	B1	8/2001	Laird	2006/0030755	A1	2/2006	Ewers et al.
6,287,280	B1	9/2001	Lampropoulos et al.	2006/0047284	A1	3/2006	Gresham
6,319,246	B1	11/2001	de la Torre et al.	2006/0052669	A1	3/2006	Hart
6,325,384	B1	12/2001	Berry, Sr. et al.	2006/0084842	A1	4/2006	Hart et al.
6,382,211	B1	5/2002	Crook	2006/0129165	A1	6/2006	Edoga et al.
6,383,162	B1	5/2002	Sugarbaker	2006/0149137	A1	7/2006	Pingleton et al.
6,413,244	B1	7/2002	Bestetti	2006/0149306	A1	7/2006	Hart et al.
6,440,063	B1	8/2002	Beane et al.	2006/0161050	A1	7/2006	Butler et al.
6,450,983	B1	9/2002	Rambo				
6,482,181	B1	11/2002	Racenet				
6,485,435	B1	11/2002	Bakal				
6,533,734	B1	3/2003	Corley, III et al.	IE	S950055	1/1994	
6,551,344	B2	4/2003	Thill	IE	S940150	2/1994	
6,579,281	B2	6/2003	Palmer et al.	IE	S940613	8/1994	
6,582,364	B2	6/2003	Butler et al.	IE	S940960	12/1994	
6,589,167	B1	7/2003	Shimomura et al.	IE	930649	3/1995	
6,589,211	B1	7/2003	MacLeod	IE	930650	3/1995	
6,613,952	B2	9/2003	Rambo	IE	950266	4/1995	
6,623,426	B2	9/2003	Bonadio et al.	IE	S950266	2/1997	
6,702,787	B2	3/2004	Racenet	IE	S960196	8/1997	
6,723,044	B2	4/2004	Pulford et al.	IE	S970810	11/1997	
6,814,078	B2	11/2004	Crook	IE	990218	11/2000	
6,846,287	B2	1/2005	Bonadio et al.	IE	990219	11/2000	
6,866,861	B1	3/2005	Luhman	IE	990220	11/2000	
6,895,965	B2	5/2005	Scarberry et al.	IE	990660	2/2001	
6,902,541	B2	6/2005	McNally et al.	IE	990795	3/2001	
6,908,430	B2	6/2005	Caldwell et al.	JP	11-290327	10/1999	
6,939,296	B2	9/2005	Ewers et al.	JP	2002-28163	1/2002	
6,945,932	B1	9/2005	Caldwell et al.	JP	02003 235879 A	8/2003	
6,958,037	B2	10/2005	Ewers et al.	WO	WO 95/07056	3/1995	
6,972,026	B1	12/2005	Caldwell et al.	WO	WO95/07056	3/1995	
6,997,909	B2	2/2006	Goldberg	WO	WO95/22289	8/1995	
7,033,319	B2	4/2006	Pulford et al.	WO	WO 95/24864	9/1995	
7,052,454	B2	5/2006	Taylor	WO	WO 95/27468	10/1995	
7,081,089	B2	7/2006	Bonadio et al.	WO	WO 97/11642	4/1997	
7,214,185	B1	5/2007	Rosney et al.	WO	WO 98/19853	5/1998	
2001/0037053	A1	11/2001	Bonadio et al.	WO	WO 98/35614	8/1998	
2001/0047188	A1	11/2001	Bonadio et al.	WO	WO 98/48724	11/1998	
2002/0002324	A1	1/2002	McManus	WO	WO 99/15068	4/1999	
2002/0038077	A1	3/2002	de la Torre et al.	WO	WO 99/25268	5/1999	
2002/0072762	A1	6/2002	Bonadio et al.	WO	WO00/32116	6/2000	
2003/0040711	A1	2/2003	Racenet et al.	WO	WO 0035356	6/2000	
2003/0139756	A1	7/2003	Brustad	WO	WO 00/32120	8/2000	
2003/0187376	A1	10/2003	Rambo	WO	WO00/54675	9/2000	
2003/0192553	A1	10/2003	Rambo	WO	WO00/54676	9/2000	
2003/0225392	A1	12/2003	McMichael et al.	WO	WO00/54677	9/2000	
2004/0015185	A1	1/2004	Ewers et al.	WO	WO01/08581	2/2001	
2004/0024363	A1	2/2004	Goldberg	WO	WO 01/26559	4/2001	
2004/0049099	A1	3/2004	Ewers et al.	WO	WO02/34108	5/2002	
2004/0049100	A1	3/2004	Butler et al.	WO	WO03/032819	4/2003	

FOREIGN PATENT DOCUMENTS

WO	WO03/034908	5/2003
WO	WO03/061480	7/2003
WO	WO 03/077726	9/2003
WO	WO 03/103548	12/2003
WO	WO 2004/075730 A2	9/2004
WO	WO 2004/075730 A3	9/2004
WO	WO 2004/075741 A2	9/2004
WO	WO 2004/075741 A3	9/2004
WO	WO 2004/075930 A2	9/2004
WO	WO 2004/075930 A3	9/2004
WO	WO 2005/034766 A2	4/2005

OTHER PUBLICATIONS

International Search Report and Written Opinion of the International Searching Authority for PCT application No. PCT/US04/05484.
 Neil Sheehan, Supplemental Expert Report of Neil Sheehan, Re: U.S. Patent No. 5,741,298, United States District Court for the Central District of California, Civil Action No. SACV 03-1322 JVS, Aug. 9, 2005.
 Horigane, et al., Technical Note: Development of a Duodenal Cannula for Sheep, *Journal of Animal Science*, Apr. 1992, vol. 70, Issue 4, pp. 1216-1219.
 Horigane, et al., Silicone Rumen Cannula with a Soft Cylindrical Part and a Hard Flange, *Journal of Dairy Science*, Nov. 1989, vol. 72, No. 11, pp. 3230-3232.
 McSweeney, Cannulation of the Rumen in Cattle and Buffaloes, *Australian Veterinary Journal*, Aug. 1989, vol. 66, No. 8, pp. 266-268.
 Yamazaki et al., Diurnal Changes in the Composition of Abomasal Digesta in Fasted and Fed Sheep, *The Tohoku Journal of Agricultural Research*, Mar. 1987, vol. 37, No. 3-4, pp. 49-58.

European Patent Office, Supplementary European Search Report for European Application No. EP 01 97 3379, dated Jul. 5, 2007, based on International Patent Application No. PCT/US01/29682, filed Sep. 21, 2001.
 US 5,344,646, Chen (withdrawn).
 Co-Pending U.S. Appl. No. 10/381,220, filed Mar. 20, 2003; Title: Surgical Access Apparatus and Method.
 Co-Pending U.S. Appl. No. 10/516,198, filed Nov. 30, 2004; Title: Wound Retractor.
 Co-Pending U.S. Appl. No. 10/927,551, filed Aug. 25, 2004; Title: Surgical Access System.
 Co-Pending U.S. Appl. No. 11/755,305, filed May 30, 2007; Title: Wound Retraction Apparatus and Method.
 Co-Pending U.S. Appl. No. 11/245,709, filed Oct. 7, 2005; Title: Surgical Access System.
 Co-Pending U.S. Appl. No. 11/330,661, filed Jan. 12, 2006; Title: Sealed Surgical Access Device.
 Co-Pending U.S. Appl. No. 11/548,746, filed Oct. 12, 2006; Title: Method of Making a Hand Access Laparoscopic Device.
 Co-Pending U.S. Appl. No. 11/548,758, filed Oct. 12, 2006; Title: Split Hoop Wound Retractor With Gel Pad.
 Co-Pending U.S. Appl. No. 11/548,765, filed Oct. 12, 2006; Title: Split Hoop Wound Retractor.
 Co-Pending U.S. Appl. No. 11/548,767, filed Oct. 12, 2006; Title: Circular Surgical Retractor.
 Co-Pending U.S. Appl. No. 11/548,781, filed Oct. 12, 2006; Title: Wound Retractor With Gel Cap.
 Co-Pending U.S. Appl. No. 11/548,955, filed Oct. 12, 2006; Title: Hand Access Laparoscopic Device.
 Co-Pending U.S. Appl. No. 11/564,409, filed Nov. 29, 2006; Title: Surgical Instrument Access Device.

* cited by examiner

Fig. 1

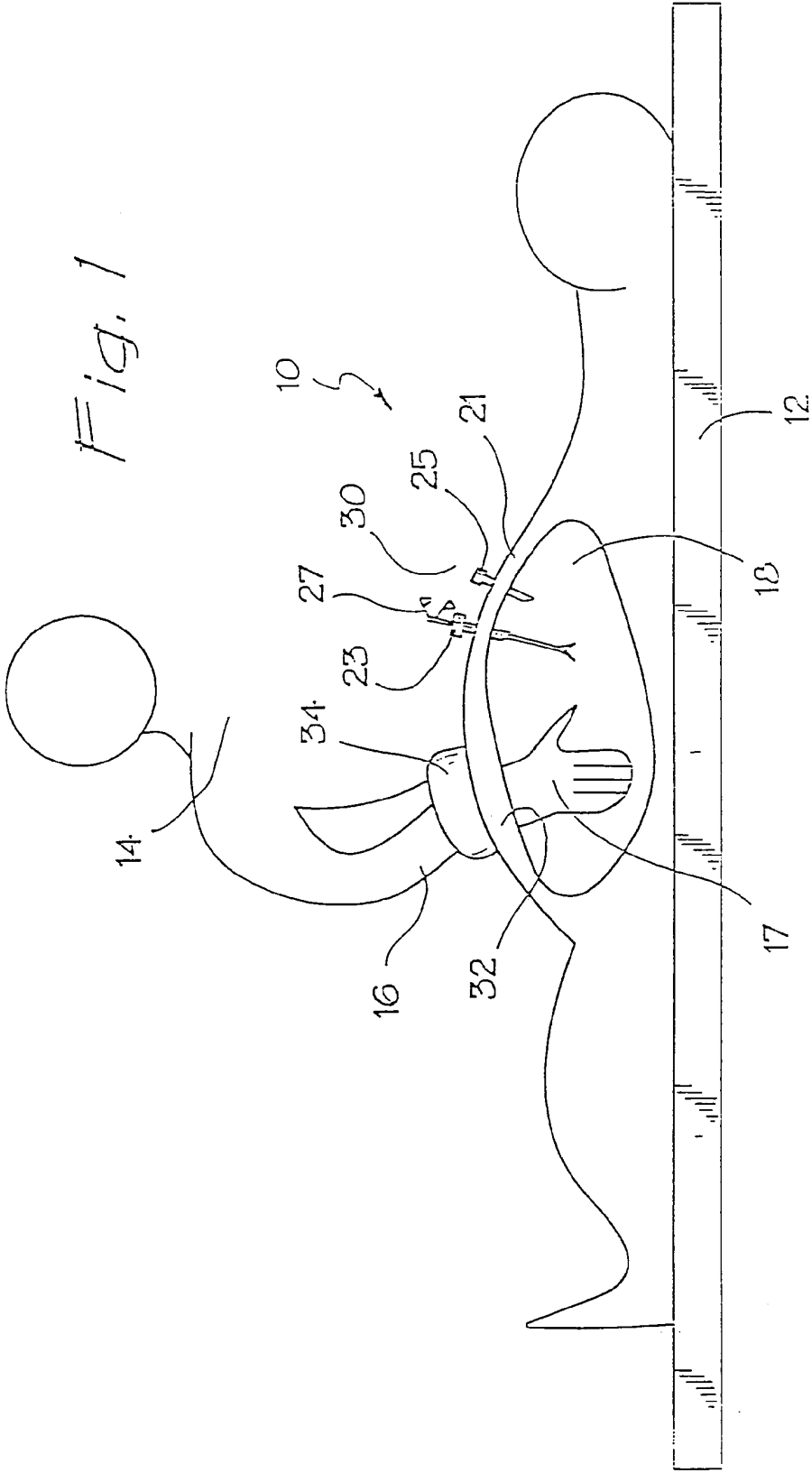

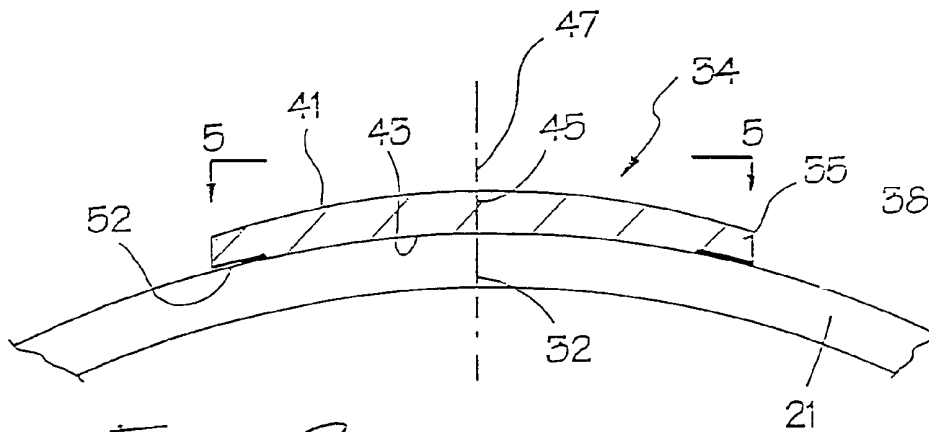

Fig. 2

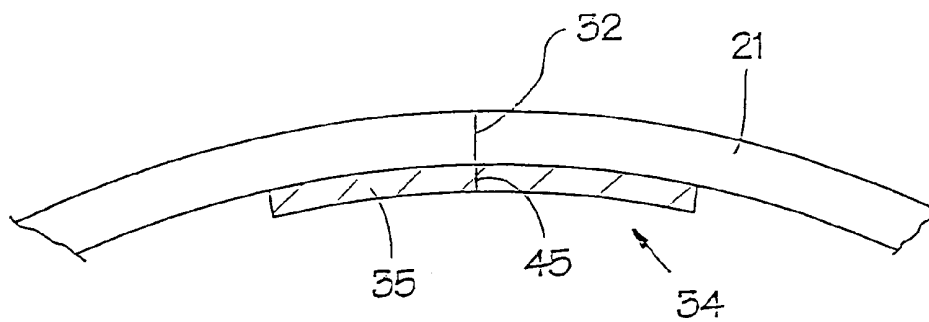

Fig. 3

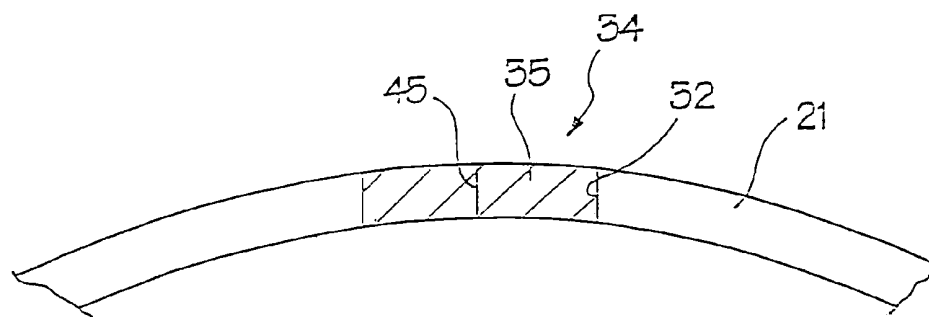

Fig. 4

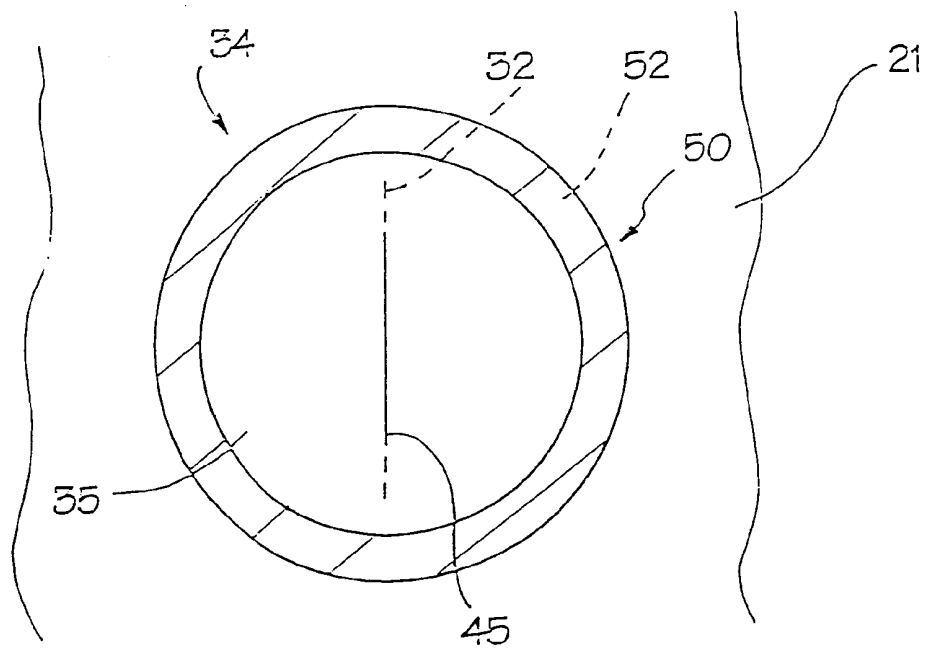

Fig. 5

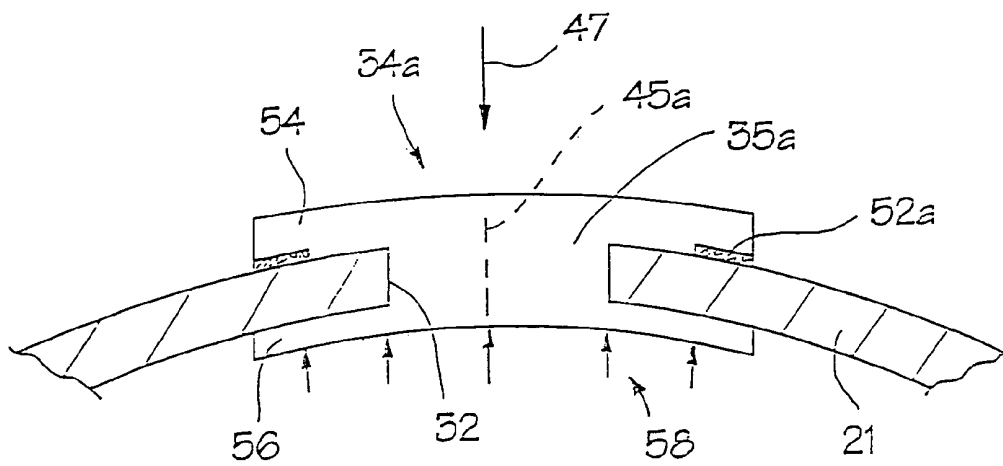
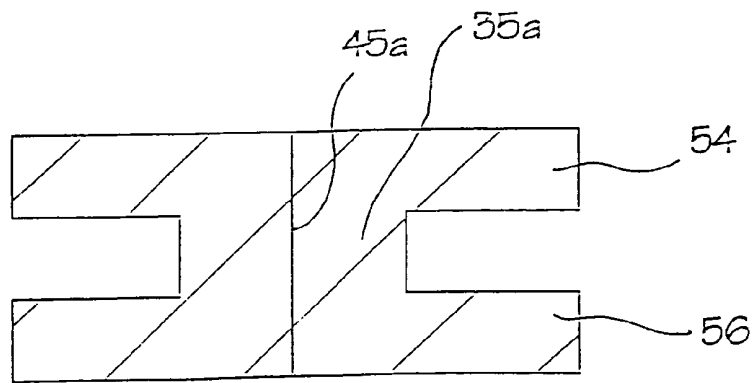
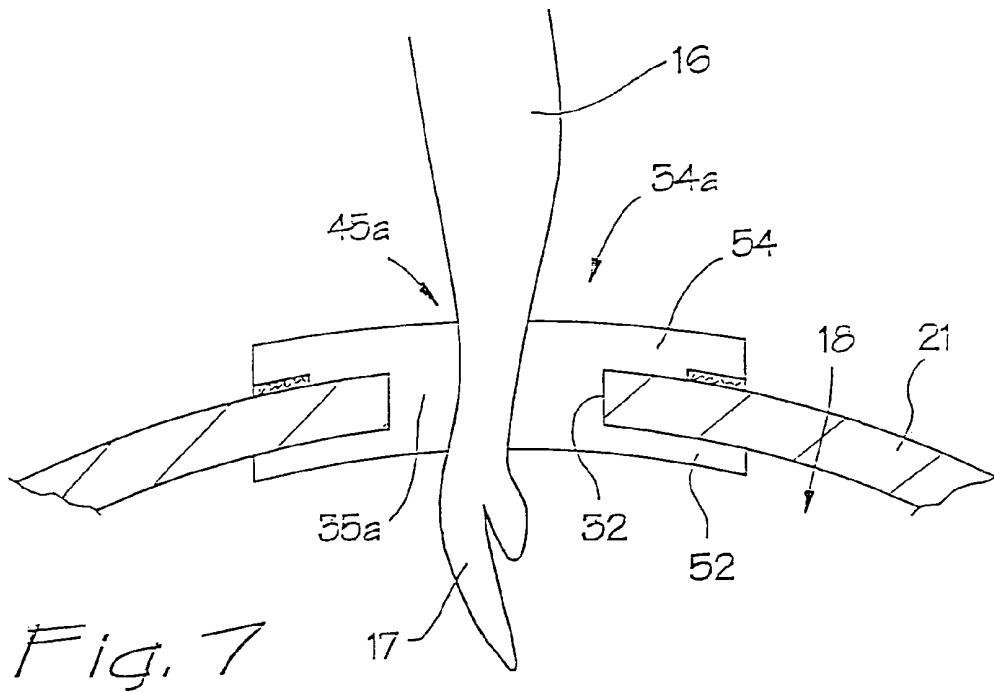
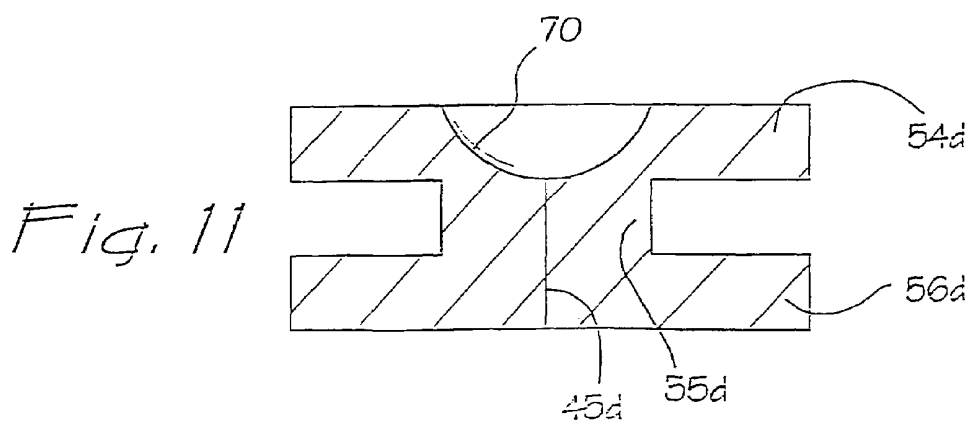
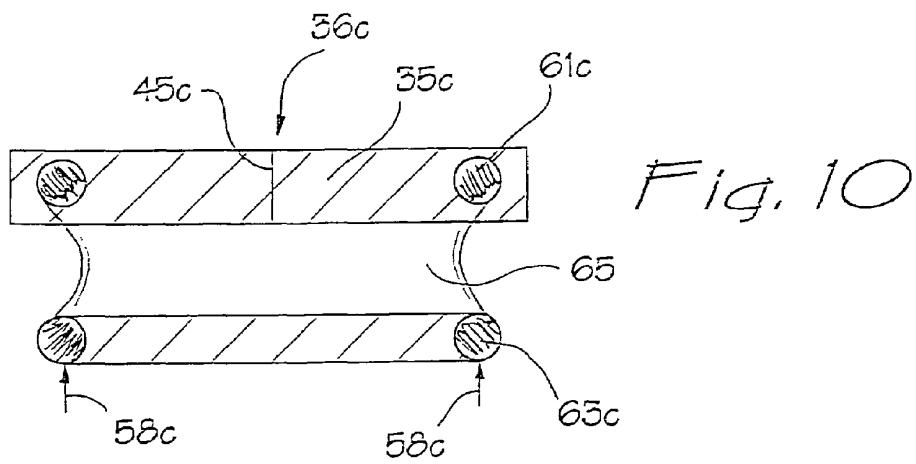
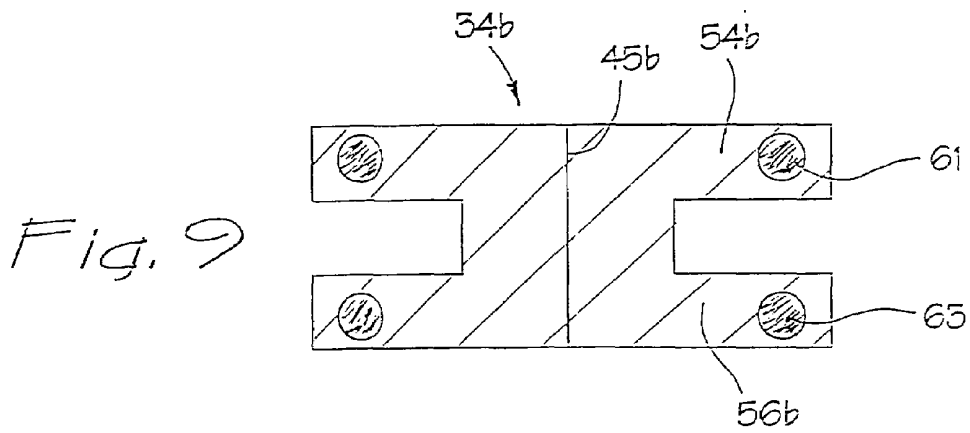

Fig. 6





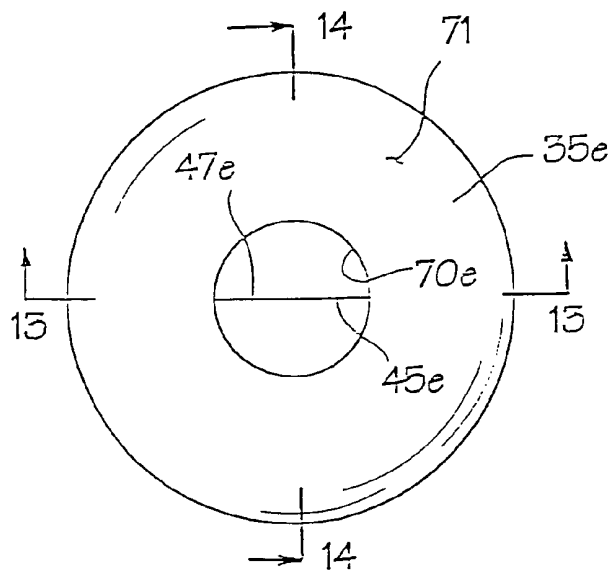

Fig. 12

Fig. 13

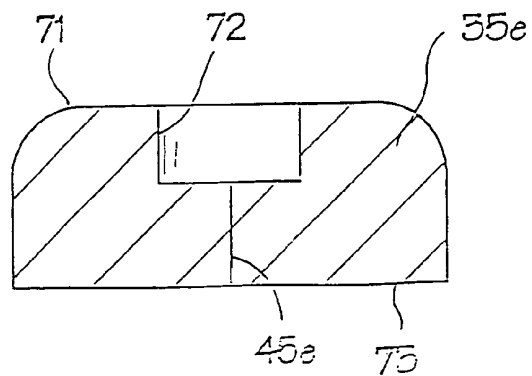
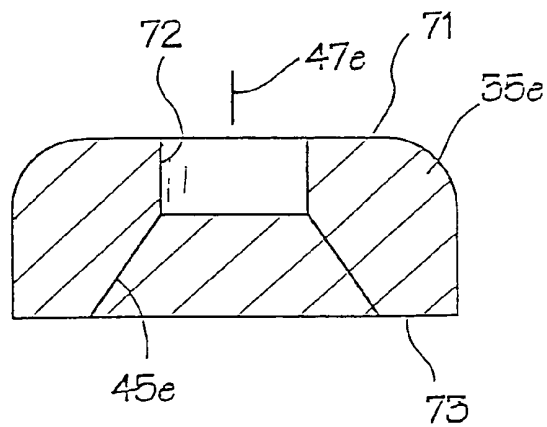

Fig. 14

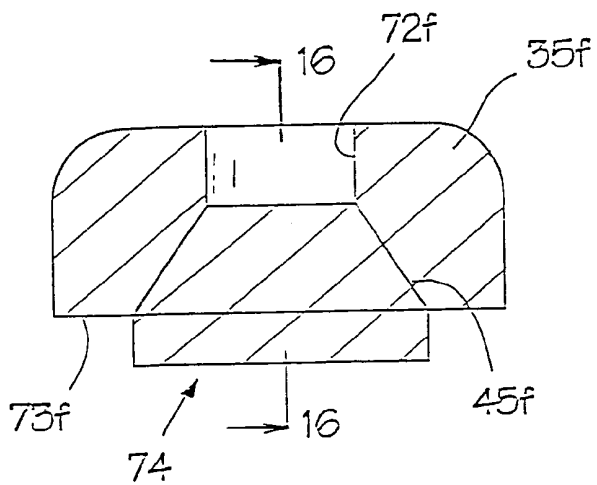

Fig. 15

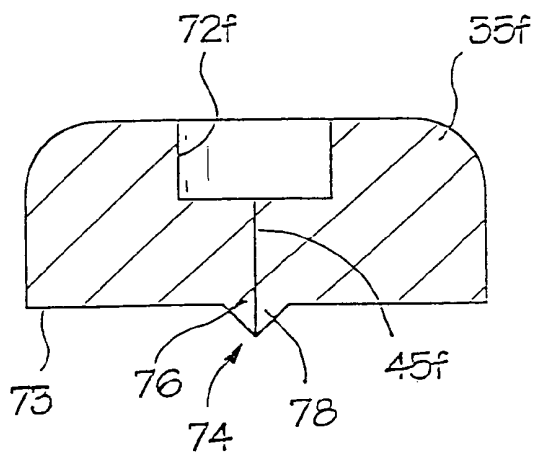

Fig. 16

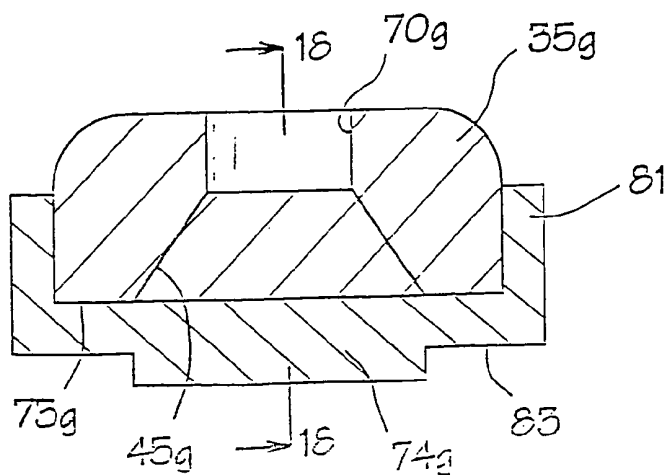

Fig. 17

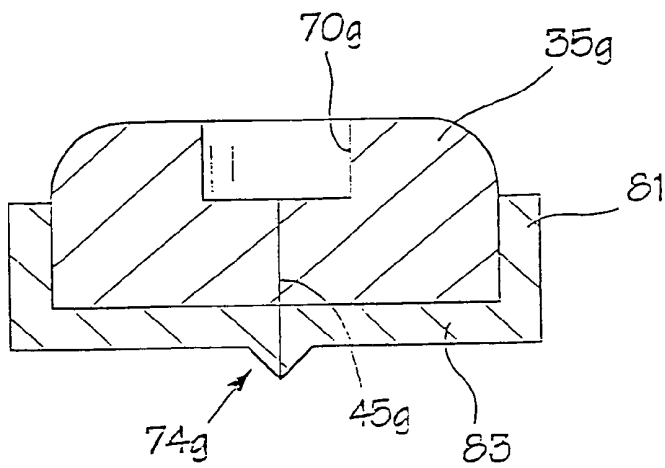

Fig. 18

Fig. 19

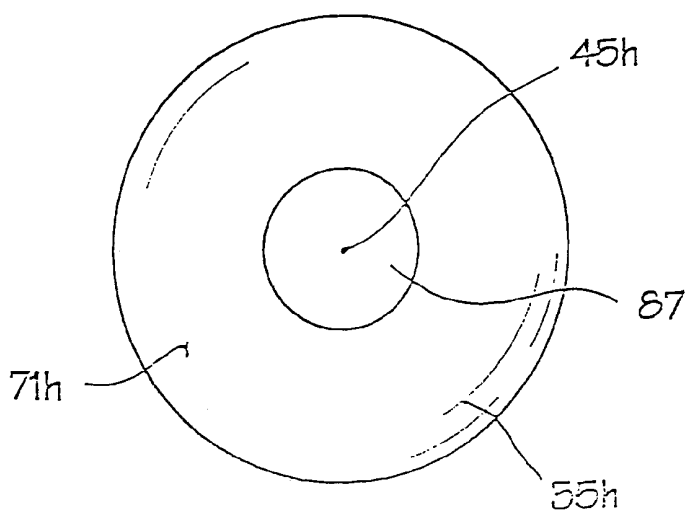
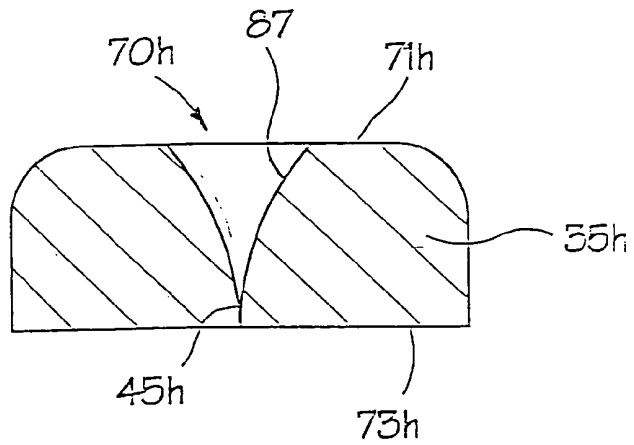

Fig. 20

Fig. 21

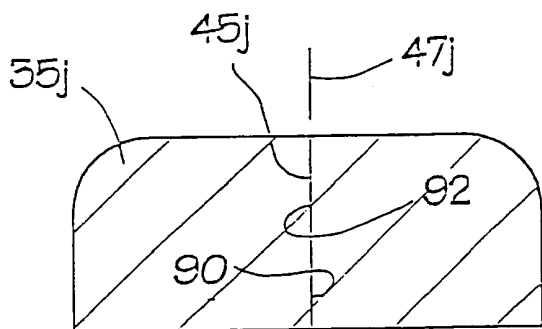
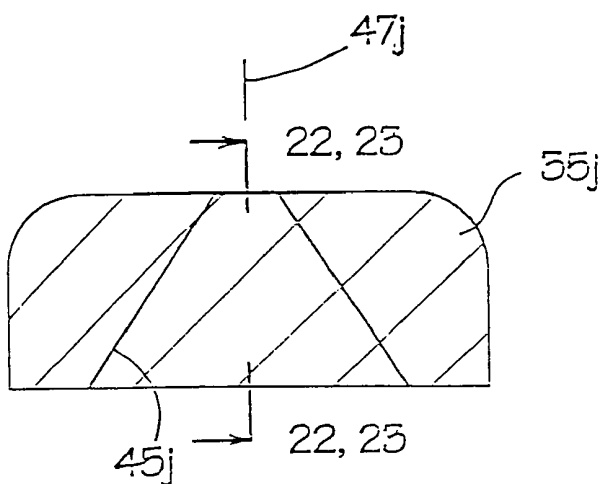
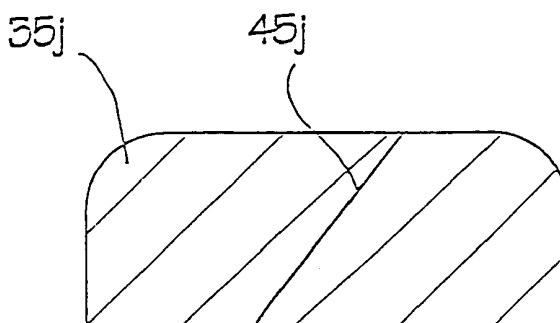

Fig. 22

73j

Fig. 23



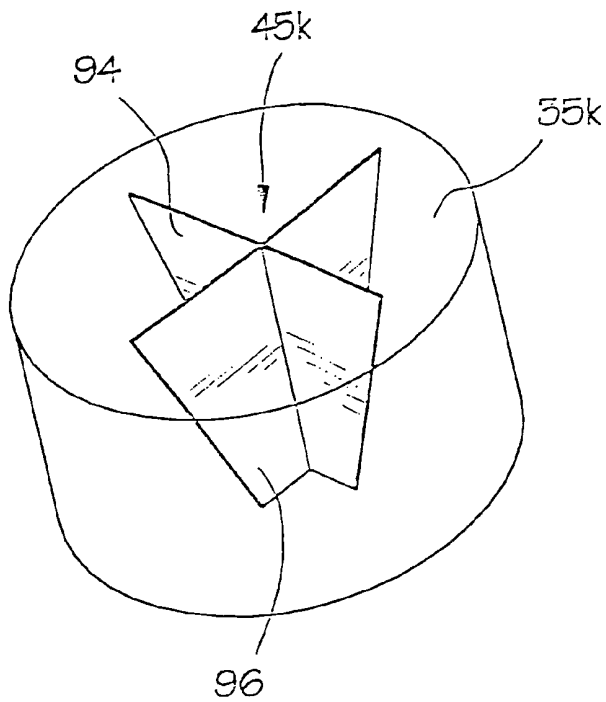

Fig. 24

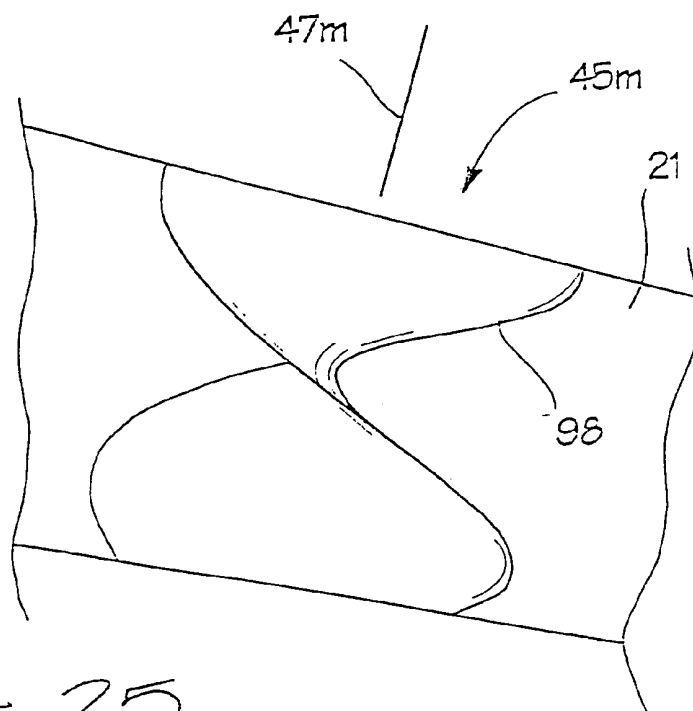

Fig. 25

Fig. 26

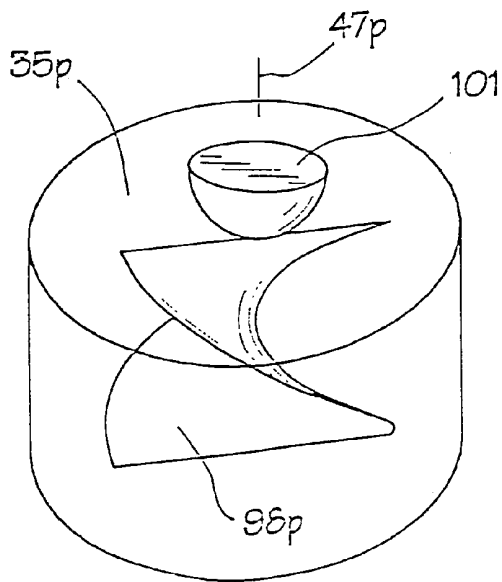
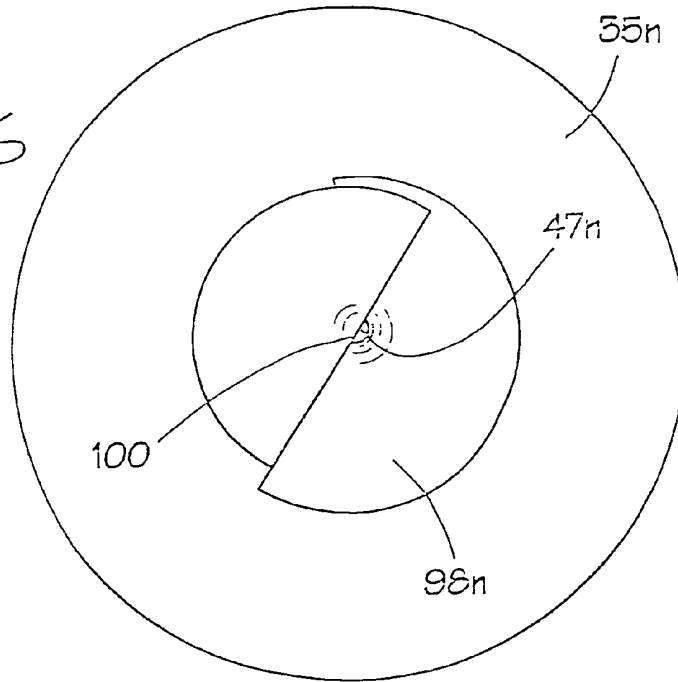

Fig. 27

Fig. 28

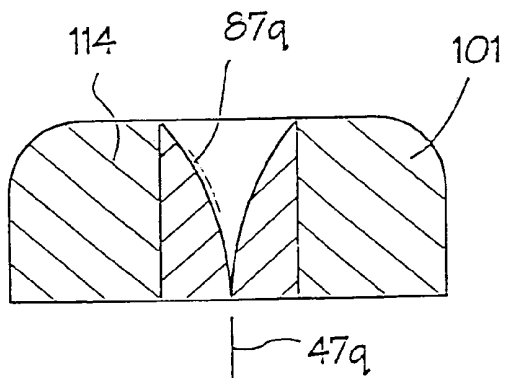
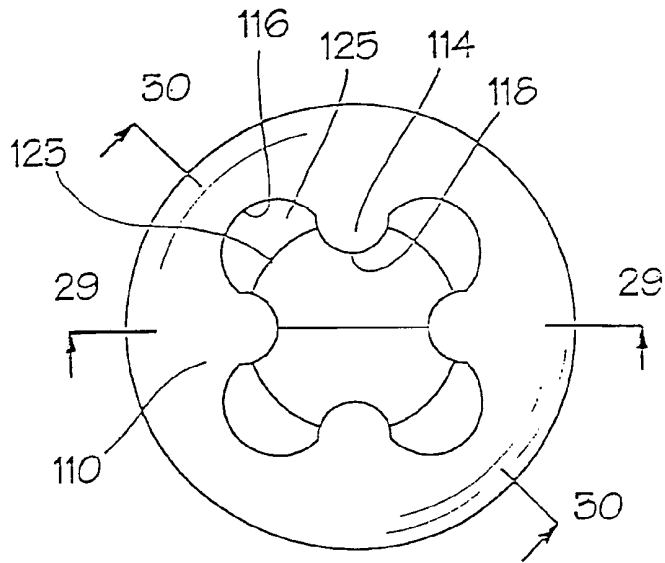

Fig. 29

Fig. 30

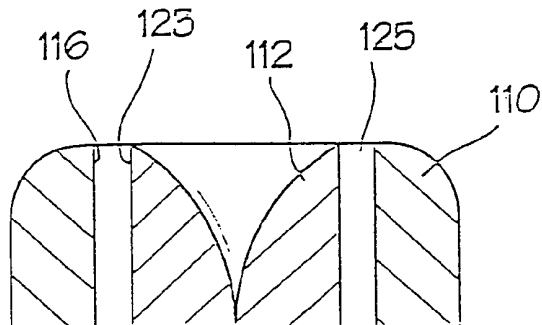

Fig. 31

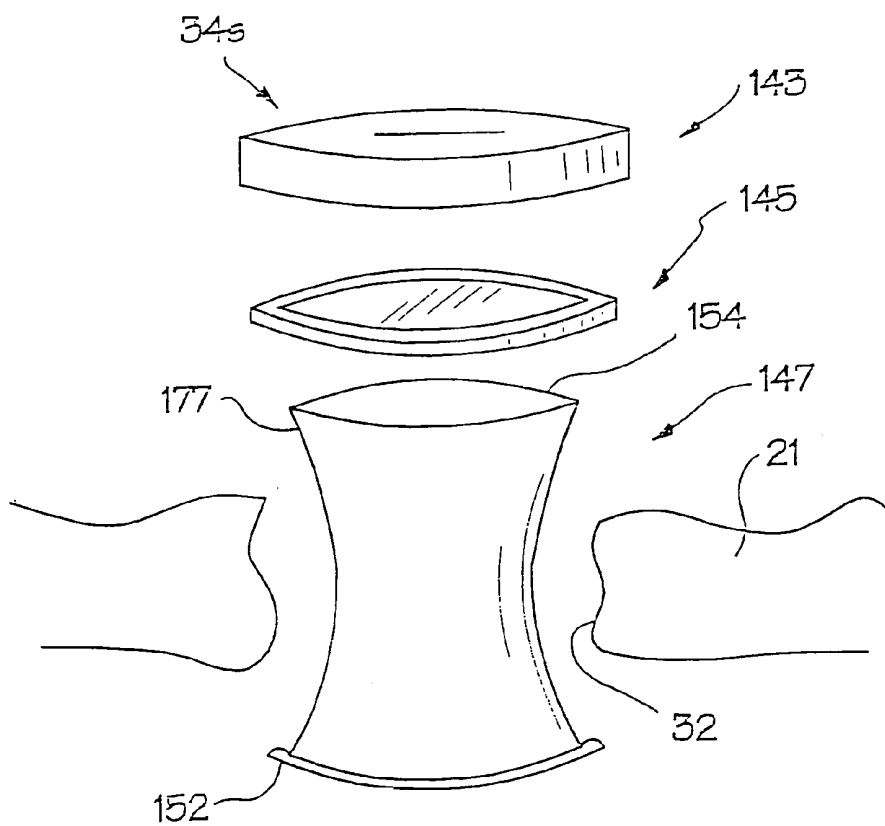
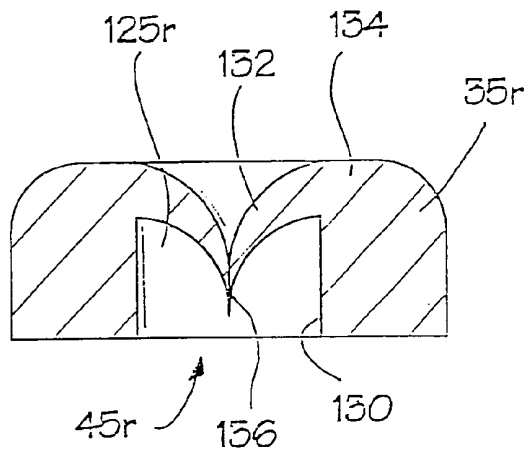

Fig. 32

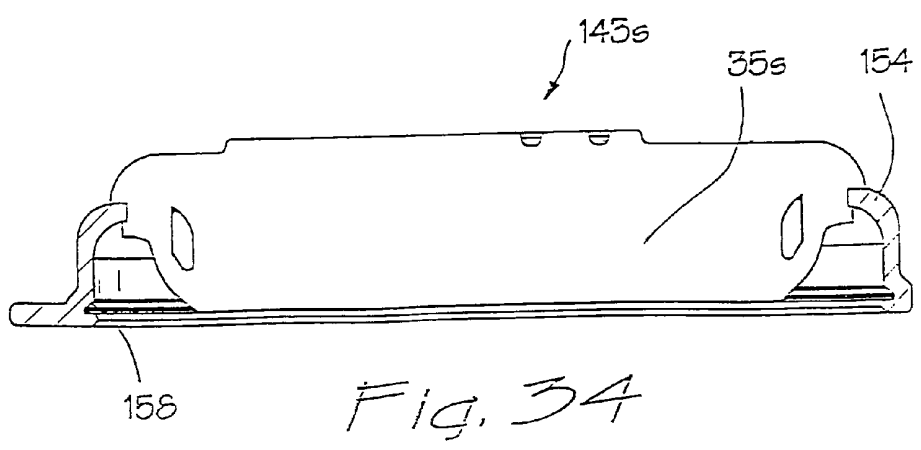
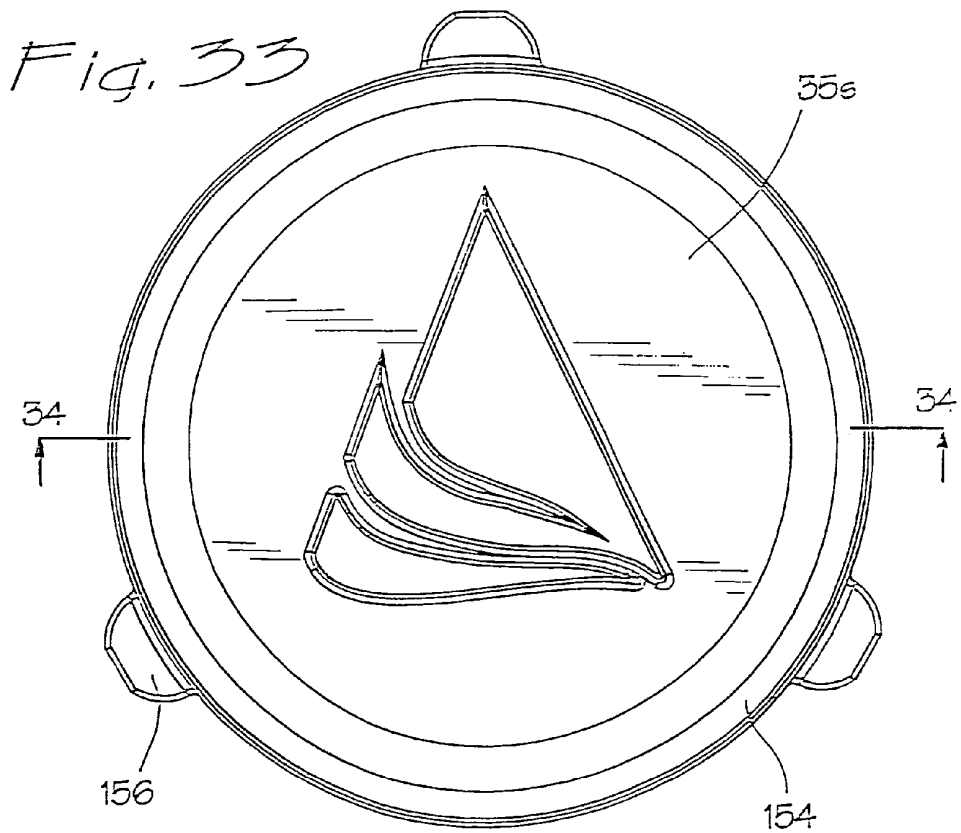

Fig. 35

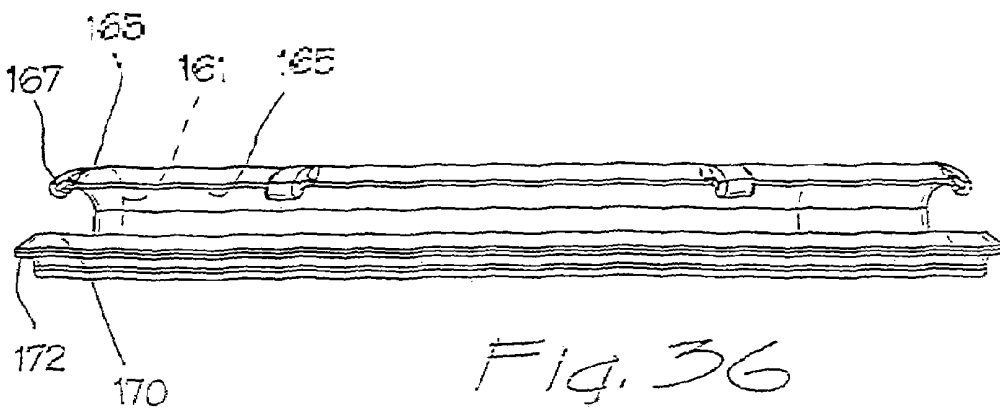
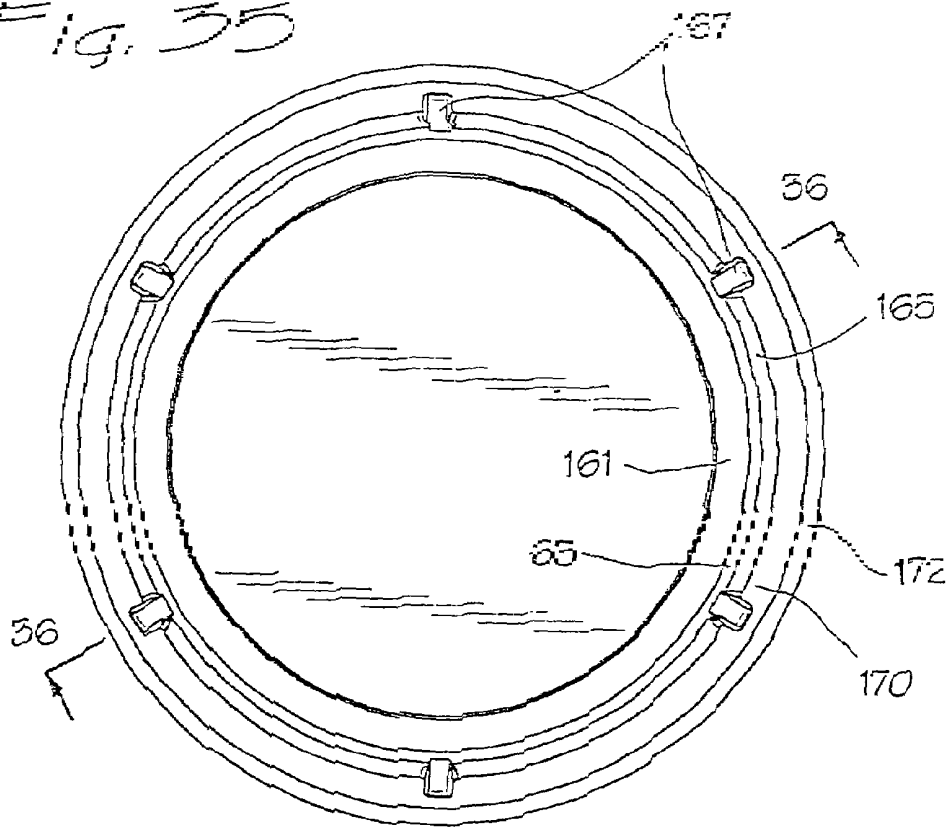

Fig. 36

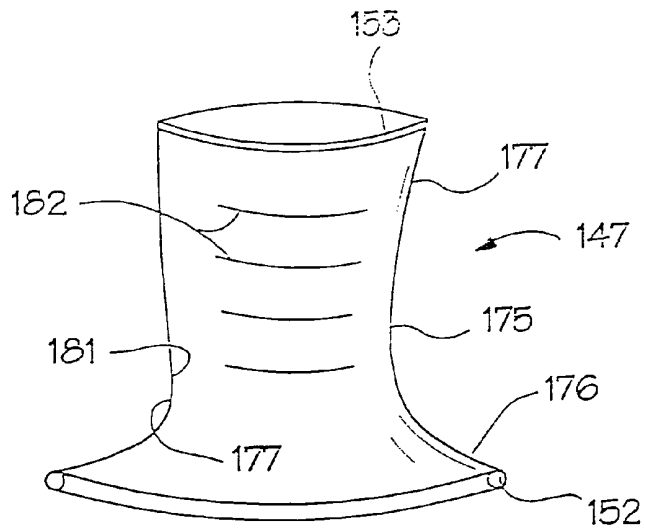

Fig. 37

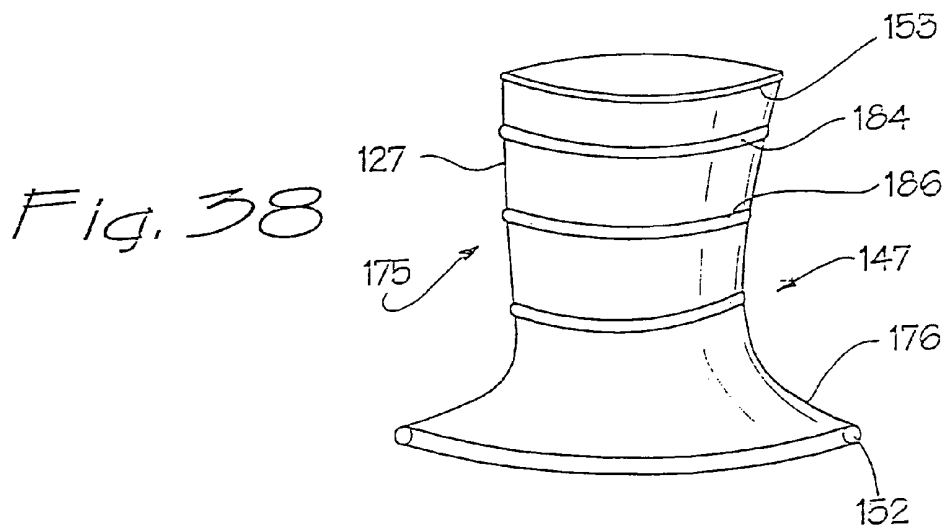

Fig. 38

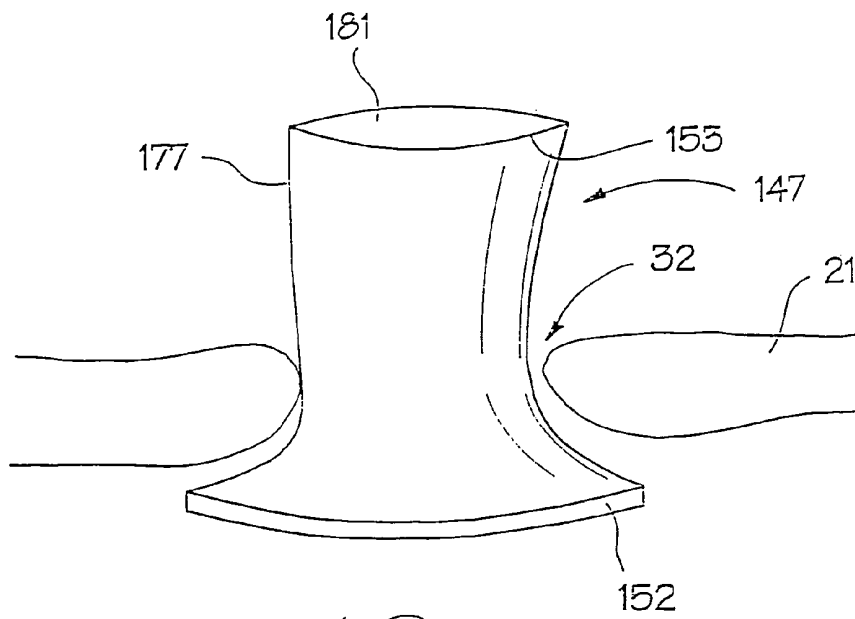
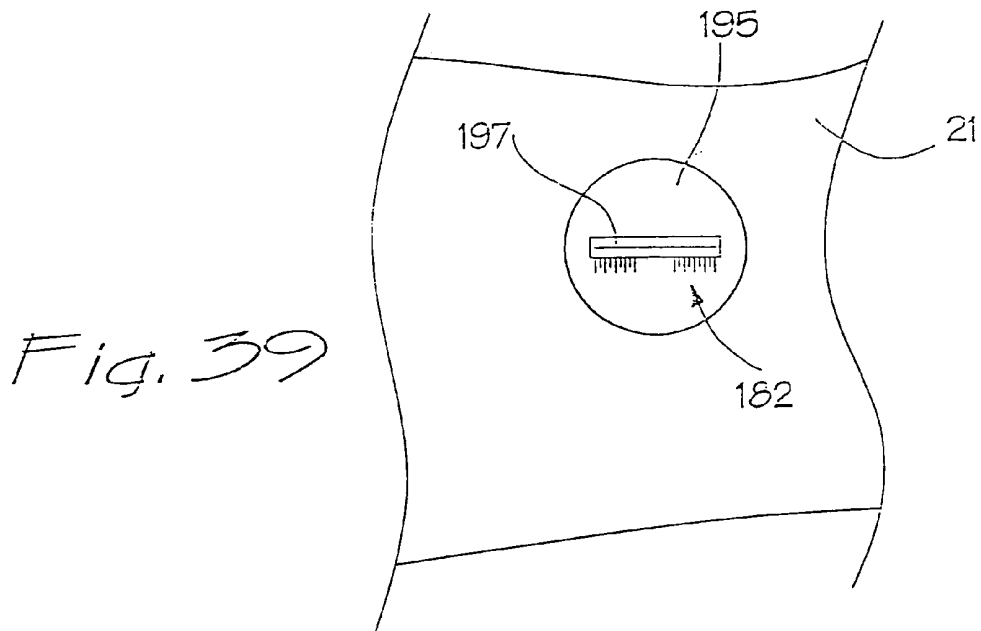
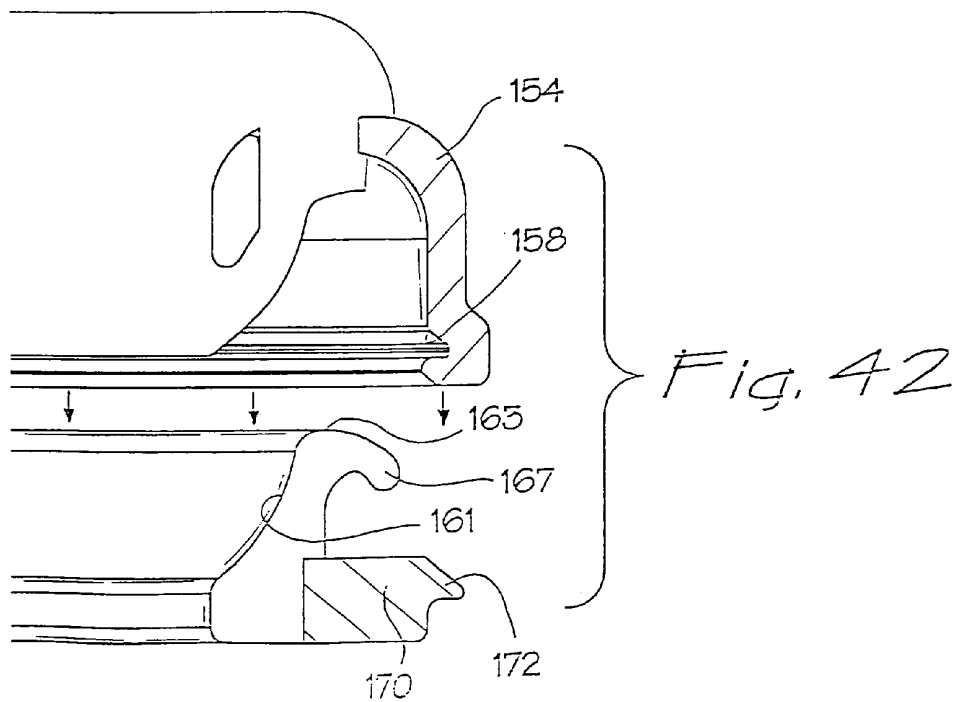
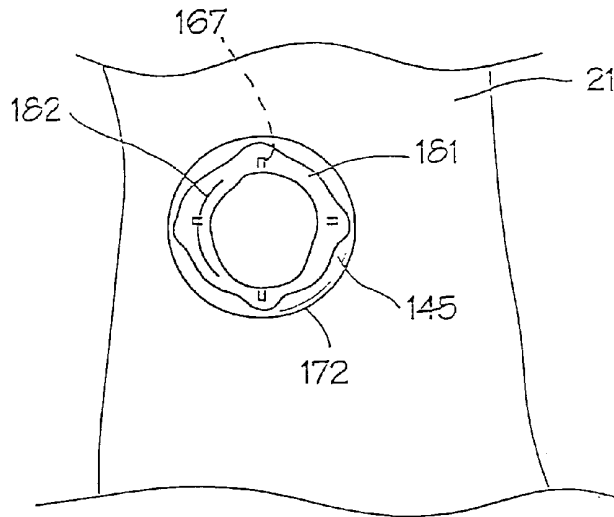

Fig. 40

Fig. 41



1

SURGICAL ACCESS APPARATUS AND METHOD

CROSS-REFERENCE TO RELATED APPLICATIONS

This application is a continuation of U.S. patent application Ser. No. 10/381,220, filed on Mar. 20, 2003, which claims benefit of U.S. Provisional Patent Application No. 60/241,958, filed on Oct. 19, 2000, the disclosures of which are hereby incorporated by reference as if set forth in full herein.

BACKGROUND OF THE INVENTION

1. Field of the Invention

This invention relates generally to devices and other apparatus facilitating sealed access with surgical instruments, such as a surgeon's hand, across a body wall and into a body cavity.

2. Background of the Invention

In several areas of surgery there exists a need to have mechanisms or devices that can seal a body cavity or space, and yet permit the introduction of surgical instruments such as guidewires, endoscopes, and even the hand of a surgeon. Typical of these areas of surgery is laparoscopic surgery which relies on surgical instruments inserted through the abdominal wall to reach an operative site within the abdominal cavity. In order to increase space around the operative site within the cavity, insufflation gases are typically introduced to inflate the cavity and elevate the abdominal wall. This pressurizing of the abdominal cavity is referred to as pneumoperitoneum. In this context, the need to seal the body cavity or space arises from the need to maintain the pneumoperitoneum even when instruments are present.

Trocars have been commonly used to provide instrument access in laparoscopic surgeries. These trocars have included elaborate seal structures having zero seals which prevent escape of the gases in the absence of instruments, and instrument seals which prevent escape of the gases in the presence of instruments. Unfortunately, the instrument seals have been able to accommodate only a narrow range of instrument diameters. Where wider ranges were desired multiple seal pairs had to be provided.

Some instruments, such as the hand of the surgeon, have been too large for trocar access. Under these circumstances, hand-assisted laparoscopic seals have been provided. Such devices have been large, cumbersome, and largely ineffective in providing the required sealing mechanism. Other access devices, such as Touhy-Borst seals, have been used but only for very small diameter access such as that required by a guidewire.

Each of the prior devices suffers from drawbacks which make the device difficult or cumbersome to use. For example, a Touhy-Borst seal requires two hands to use and does not form a seal when a guidewire or other device is about to be introduced. Present trocar seals and hand-assisted seals require two valves, one forming an instrument seal in the presence of the instrument, and the other forming a zero seal in the absence of the instrument. For example, in hand-assisted devices, elaborate mechanisms have been required to

2

seal around the surgeon's arm. When the arm is removed, a separate zero seal has been required to prevent the escape of blood or insufflation gases.

SUMMARY OF THE INVENTION

These deficiencies of the prior art are overcome with the present invention which includes both a seal apparatus and a method for using this apparatus to perform elaborate surgeries. In one embodiment, the device includes a valve structure formed of a gel including, for example, a thermoplastic base such as KRATON (a trademark of Shell Corporation) and an oil. The resulting elastomer has an excellent tear strength, elongation greater than 1,000 percent, a very low durometer or hardness, and biocompatibility. A process for manufacturing this device is greatly simplified using molding techniques.

Importantly, the access device can function as both a zero seal and an instrument seal. Furthermore, it can accommodate a full range of instrument diameters, such as a range from two French in the case of a guidewire, to three or four inches in the case of a surgeon's hand. In addition, several instruments can be accommodated at the same time with a single access device.

Both tear resistance and sealing capability can be enhanced by encapsulating the gel in a sheath or otherwise providing circumferential reinforcement for the valve structure. Additives can be provided either on or in the gel to enhance properties such as lubricity, appearance, wound treatment and/or protection, anti-cancer protection and anti-microbial protection. Additional chemicals, compounds, pharmaceuticals or even mechanical devices can be mixed with or embedded in the gel material to vary chemical, pharmaceutical or physical properties of the access device.

These and other features and advantageous of the invention will be clarified with a description of preferred embodiments and reference to the associated drawings.

DESCRIPTION OF THE DRAWINGS

FIG. 1 is a perspective view showing a patient prone on an operating table with his abdomen insufflated, and with instrument access provided by trocars and the access device of the present invention;

FIG. 2 is an enlarged side elevation view of the access device of FIG. 1 operatively disposed exteriorly as the abdominal wall;

FIG. 3 is a side elevation view similar to FIG. 2 showing the access device operatively disposed interiorly of the abdominal wall;

FIG. 4 is a side elevation view similar to FIG. 2 showing the access device operatively disposed within an incision in the abdominal wall;

FIG. 5 is a plan view taken along lines 5-5 of FIG. 2;

FIG. 6 is a side elevation view similar to FIG. 2 and illustrating a further embodiment of the access device having an external flange and an internal flange;

FIG. 7 is a side elevation view similar to FIG. 6 and illustrating the hand of a surgeon being inserted through the access device;

FIG. 8 is an axially cross section view of the access device illustrated in FIG. 6;

FIG. 9 is a cross section view similar to FIG. 8 and illustrating an embodiment with circumferential reinforcement members;

FIG. 10 is an axial cross section view similar to FIG. 9 and illustrating a double-ring retractor with an access device of the present invention;

FIG. 11 is a radial cross section view similar to FIG. 8 and illustrating an embodiment having a lead-in cavity or pocket;

FIG. 12 is a top plan view of the embodiment illustrated in FIG. 11;

FIG. 13 is an axial cross section view taken along lines 13-13 of FIG. 12;

FIG. 14 is an axial cross section view taken along lines 14-14 of FIG. 12;

FIG. 15 is an axial cross section view similar to FIG. 13 and illustrating an embodiment with a duct-bill valve;

FIG. 16 is an axial cross-section view taken along lines 16-16 of FIG. 15;

FIG. 17 is a radial cross section view similar to FIG. 13 comprising a softer hand seal and a firmer base seal;

FIG. 18 is an axial cross section view taken along lines 18-18 of FIG. 17;

FIG. 19 is an axial cross section view of an embodiment having a lead-in cavity or pocket with a conical or funnel configuration;

FIG. 20 is a top plan view of the embodiment illustrated in FIG. 19;

FIG. 21 is an axial cross section view similar to FIG. 13 and showing another embodiment with a trapezoidal slit;

FIG. 22 is an axial cross section view taken along lines 22-22 of FIG. 21;

FIG. 23 is an axial cross section view similar to FIG. 22 taken along lines 23-23 of FIG. 21 and illustrating a slit having other than a perpendicular relationship to the plane of the pad;

FIG. 24 is a perspective view of a further embodiment of the access device having an opening formed by multiple slits angularly disposed and axially spaced relative to each other;

FIG. 25 is a side elevation view of an access device with a slit having a spiral configuration;

FIG. 26 is a top plan view of an access device having a spiral slit and axial channel;

FIG. 27 is a side elevation view of an embodiment having a spiral slit and a septum seal;

FIG. 28 is an axial cross section view of a further embodiment including a superelastic conical seal and a flexible base with annular spoke-like cams;

FIG. 29 is an axial cross section view taken along lines 29-29 of FIG. 22;

FIG. 30 is an axial cross section view taken along lines 30-30 of FIG. 22;

FIG. 31 is an axial cross section view similar to FIG. 28 and illustrating an embodiment including flappers;

FIG. 32 is a perspective exploded view of a further embodiment including a gel cap, a base, and a retraction sheath;

FIG. 33 is a top plan view of the gel cap of FIG. 32;

FIG. 34 is an axial cross section view taken along lines 34-34 of FIG. 33;

FIG. 35 is a top plan view of the base illustrated in FIG. 32;

FIG. 36 is an axial cross section view taken along lines 36-36 of FIG. 35;

FIG. 37 is a side elevation view of the retraction sheath illustrated in FIG. 32;

FIG. 38 is a side elevation view of a further embodiment of the retraction sheath;

FIGS. 39-42 illustrate progressive steps in a preferred method of use associated with the embodiment of FIG. 32;

FIG. 39 is a top plan view showing use of a template;

FIG. 40 is a top plan view of showing placement of the retraction sheath;

FIG. 41 is a top plan view showing placement of the base ring and securement of the traction sheath; and

FIG. 42 is an axial cross section view partially in section showing placement of the gel cap relative to the base.

DESCRIPTION OF PREFERRED EMBODIMENTS AND BEST MODE OF THE INVENTION

A patient is illustrated in FIG. 1 and designated generally by the reference numeral 10. The patient 10 is shown in a prone position on an operating table 12, where abdominal surgery is being performed by a surgeon 14 having an arm 16 and a hand 17. In the illustrated example, the operative procedure is performed within an abdominal cavity 18 with instrument access provided through an abdominal wall 21. In this type of operation, commonly referred to as laparoscopic surgery, trocars 23 and 25 are commonly used to provide minimally invasive access through the abdominal wall 21 for instruments such as a grasper 27 and an endoscope 30

Although the specific focus of this disclosure will be on a preferred laparoscopic procedure, it will be noted that laparoscopic surgery is merely representative of a type of operation wherein a procedure can be performed in a body cavity with minimal access through a body wall.

Notwithstanding the foregoing generality, it is important to note that with respect to laparoscopic surgery, it is often desirable that the surgeon 14 be able to insert his/her hand 17 through the abdominal wall 21 and into the abdominal cavity 18. This insertion of the hand 17 provides the surgeon 14 with direct access to various elements of the anatomy

In order to accommodate the hand 17 and arm 16 of the surgeon 14, a small incision 32 is typically created in the abdominal wall 21. An access device 34 of the present invention can be provided to further facilitate this access by the hand of the surgeon 14.

Particularly in the case of laparoscopic surgery, it is advantageous to insufflate the abdominal cavity 18 with a gas, such as carbon dioxide, in order to elevate the abdominal wall 21 and thereby increase the volume of the working space within the cavity 18. Maintenance of this insufflation pressure, commonly referred to as pneumoperitoneum, is particularly difficult where access is desired across the abdominal wall 21, for example, through the trocars 23, 25, as well as the access device 34. For this reason, a substantial effort has been directed to providing such access devices with sealing characteristics both in the presence of instruments and in the absence of instruments, such as the grasper 29, scope 30 and hand 27.

Thus, the trocars 23 and 25 have typically been provided with complex valve structures, including, for each narrow range of instrument sizes, an instrument valve which forms an instrument seal in the presence of an instrument, and a zero valve which forms a zero seal in the absence of an instrument. By providing both an instrument seal and a zero seal the valve structures have been able to inhibit the escape of gases through the trocars both in the presence and the absence of an instrument, respectively.

The instrument seals have been particularly cumbersome, as noted, and have only been effective for a small range of instrument diameters. For example, separate instrument seals have been needed for instruments, such as guidewires, which may have a diameter of only two French to three French. For medium-sized instruments having diameters of three millimeter to five millimeters, a second instrument seal has been required. In some cases, even a third instrument seal has been necessary in order to accommodate instruments having diameters such as nine millimeters to 12 millimeters. Typically the varying sizes of instruments have also required individual

zero seals for each range. Thus, in a complex trocar, such as the trocar **23**, there might be as many as six separate seals associated with the access device.

Were it not for the desire to maintain the pneumoperitoneum, there would be no need for the trocars **23**, **25** or the access device **34**. One would merely cut an incision in the abdominal wall **21** and insert the instrument directly through the incision. However, without appropriate valves or seals, the insufflation gases would merely escape through the incisions. This would be particularly detrimental in the case of the incision **32** which must be sufficiently large to accept the hand **17** of the surgeon **14**. Thus it is a primary purpose of the access device **34** to form with the incision **32** an access or working channel **34**, and to provide a valve or other sealing structure across the working channel **34** in order to maintain the pneumoperitoneum.

An enlarged view of one embodiment of the access device **34** is illustrated in FIG. 2 which also shows the abdominal wall **21** and the incision **32**. In this simple form, the access device **34** has the general configuration of a pad **35**, meaning that it is generally flat and disposed in a plane such as the plane **38**. Typically parallel to this plane **38** are a pair of major surfaces of **41** and **43** which provide the pad **35** with a substantial surface area. An opening or slit **45** can be formed through the pad **35**, generally along an axis **47** perpendicular to the plane **38**.

When operatively disposed, the opening **45** of the pad **35** is in communication with the incision **32** and, in this case, forms with the incision **32**, the working channel **36**. The alignment of the opening **45** and incision **32** can occur with the pad **35** disposed exteriorly of the abdominal wall as illustrated in FIG. 2, interiorly of the abdominal wall is **21** as illustrated in FIG. 3, or within the abdominal wall **21** as illustrated in FIG. 4. In any of these positions, operative disposition of the pad **35** relative to the abdominal wall **21** requires that the pad **35** be maintained in its operative position and that it form a seal around the incision **32**. Referring to the plan view of FIG. 5, these two functions are accomplished with an adhesive **50** disposed around the incision **32** between the pad **35** and the abdominal wall **21**.

If this adhesive **50** is formed as a continuous ring **52**, as illustrated in FIG. 5, the pad **35** can be disposed with the ring **52** positioned circumferentially around the incision **32** to form a seal between the pad **35** and the abdominal wall **21**. In the illustrated example, when the pad **35** is operatively positioned, the escape of insufflation gases is inhibited between the pad **35** and the abdominal wall **21** by the adhesive ring **52**.

The escape of insufflation gases is inhibited through the opening **45** of the pad **35** by the self-sealing characteristics of the material forming the pad **35**. This material and its highly advantageous properties are discussed in significant detail below.

It will be appreciated that the functions of the adhesive ring **52** can be accomplished in many different ways using many different materials and shapes. For example, many materials other than adhesives can be used to maintain the pad **35** in position over the incision **32**. The formation of a seal around the incision **32** can also be accomplished with methods other than adhesion. Furthermore, the shape of the continuous seal formed by the adhesive **50** need not be in the shape of a circle. Rather, any continuous pattern sufficiently large to form a perimeter around the incision **32** could facilitate the desired sealing relationship. Finally, it will be noted that the mere placement of the pad **35**, for example, interiorly of the abdominal wall **21** as illustrated in FIG. 3, may produce a perimeter seal merely as a result of the insufflation pressure.

A further embodiment of the access device **32** is illustrated in FIG. 6 where elements of structure similar to those previously disclosed or designated with the same reference numeral followed by the lower case "a." In this embodiment, the functions of position-maintenance and sealing are accomplished with an alternative configuration for the access device itself. The pad **35** in this case is disposed within the incision **32** as illustrated in FIG. 4. However, an external flange **54** and an internal flange **56** are formed integral with the pad **35**.

When operatively disposed, the external flange **54** is positioned outside of the abdominal wall **21** while the internal flange **56** is disposed interiorly of the abdominal wall **21a**. In this matter, the pad **35** can be disposed within the incision **32a** and held in position by the flanges **54**, **56**. When the hand **17** of the surgeon **14** is inserted through the access device **34**, the exterior flange **54** prevents the pad **35a** from moving distally. Similarly, when the hand **17** of the surgeon **14** is withdrawn, the interior flange **56** prevents the pad **35a** from moving proximally.

In this embodiment, the opening **45a** extends through the pad **35a** as well as the flanges **54** and **56**, and completely defines the working channel **34** through the incision **32**.

The primary seal which is required between the access device **34a** and the abdominal wall **21**, can be formed with the adhesive ring **52a** as discussed with reference to FIG. 6. Alternatively, this embodiment including the interior flange **56** may rely merely upon the surface contact between the flange **56a** and the abdominal wall **21**. In this case, the primary seal can be formed between these structural elements and enhanced by the pneumoperitoneum pressure which forces the interior flange **56** against the abdominal wall as illustrated by a plurality of arrows **58**. This seal is formed primarily in a radial plan generally perpendicular to the axis **47**.

The function of the primary seal may be further enhanced by additional sealing which occurs between the pad **35a** and the portions of the abdominal wall **21** forming the incision **32**. In this location, the abdominal wall **21** is radially compressed by the mere presence of the pad **35** within the incision **32**. The resulting pressure produces an axial seal between the pad **35a** and the abdominal wall **21**.

If the adhesive ring **52a** is desired for this embodiment, it is most advantageously placed around the incision **32**, between the exterior flange **54** and the abdominal wall **21**.

It will be noted that whenever an instrument, such as the arm **16** or hand **17** of the surgeon **14**, is inserted through the pad **35**, the material of the pad conforms to the surface of the instrument and forms the instrument seal with the instrument. Accordingly, during the entire period beginning with insertion of the instrument and ending with withdrawal of the instrument, there is substantially no loss of insufflation gas through the pad **35a** nor any loss of pneumoperitoneum within the abdominal cavity **18**.

With further reference to FIG. 7, it will be appreciated that the arm **16** and hand **17** of the surgeon **14** are merely examples of instruments which can be inserted through the access device **34a**. In the absence of the instrument, or hand **17** in the case of FIG. 7, the opening or slit **45a** merely closes against itself to form a zero seal, thus preventing the escape of insufflation gases through the access device **34a**. When the instrument, such as the hand **17**, is inserted through the opening or slit **45a**, an instrument seal is formed between the material of the access device **34a** and the exterior surface of the instrument. This prevents the escape of insufflation gases through the access device **34a**, even when an instrument is present. Thus, insufflation pressures can be maintained within the abdominal cavity **18** whether or not the instrument is in place.

Note that these seals, the zero seal and the abdominal seal, can be formed as a single valve structure having properties for accommodating a full range of instrument sizes.

Formation of the pad 35a will typically be accomplished in a simple molding process described in greater detail below. In such a process, the opening or slit 45a may be formed as part of the molding process.

In most cases, the single access opening 45a will be sufficient to accommodate the operative procedure. However, a further advantage of the access device 34a will be particularly appreciated by the surgeon 14 who requires even more access through the pad 35a. Consider for example, the surgeon 14 having his/her arm 16 inserted through the opening 45a when he/she decides that a further instrument is required for the operative procedure. Under these circumstances, a further opening through the pad 35a can be established by merely inserting the desired operative instrument through the pad 35a. In this manner, the instrument can create its own access hole beside the primary opening 45a.

Particularly for those operative instruments having pointed distal ends, the instrument can merely be forced through the pad 35a forming its own access hole, such as the opening 45a, as it is moved distally. This opening, created by the operative instrument itself, would automatically form an instrument seal as the instrument is inserted, as well as a zero seal as the instrument is withdrawn.

For operative instruments not having pointed distal ends, it is possible to form a new access hole using a secondary instrument, such as a trocar obturator. After the access hole is formed, the obturator can be removed, vacating the access hole to receive the operative instrument. Throughout this process of initially forming an access hole and ultimately inserting an operative instrument through the hole, both zero seals and instrument seals are formed to maintain the pneumoperitoneum.

With the advantages associated with 1) the formation of an instrument seal and a zero seal with a single valve accommodating a wide range of diameters, and 2) the formation of an instrument opening using the instrument itself, it will be appreciated that the concept of this invention will typically be embodied with a structure that is particularly dependent upon the material which forms the access device 34. In a preferred embodiment, the pad 35 is formed of a KRATON/oil mixture including a KRATON Tri-block with a Styrene-Ethylene/Butylene-Styrene (S-E/B-S) structure in combination with a mineral oil. Other tri-block polymers can be used for this application such as Styrene-Isoprene-Styrene, (S-I-S), Styrene-Butadiene-Styrene (S-B-S), Styrene-Ethylene/Propylene-Styrene (S-E/P-S) manufactured under the trademark SEPTON by the Kuraray Co. These general formulas can be further distinguished by the ratio of the styrene to rubber content: for example, Grade 1650 is a S-E/B-S tri-block with a 29/71 styrene to rubber ratio.

In addition to tri-blocks there are also di-block versions of these materials where styrene is present at only one end of the formula, for example, Styrene-Ethylene/Butylene (S-E/B) di-block.

The various base formulas may also be alloyed with one another to achieve a variety of intermediate properties. For example KRATON G1701X is a 70% S-E/B 30% S-E/B-S mixture with an overall Styrene to rubber ratio of 28/72. It can be appreciated that an almost infinite number of combinations, alloys, and Styrene to rubber ratios can be formulated, each capable of providing advantages to a particular embodiment of the invention. These advantages will typically include low durometer, high elongation, and good tear strength.

It is contemplated that the material of the pad 35 may also include silicone, soft urethanes and even harder plastics which might provide the desired sealing qualities with the addition of a foaming agent. The silicone materials can be of the types currently used for electronic encapsulation. The harder plastics may include PVC, Isoprene, KRATON neat, and other KRATON/oil mixtures. In the KRATON/oil mixture, for example, oils such as vegetable oils, petroleum oils and silicone oils might be substituted for the mineral oil. In the broadest sense, all of these mixtures can be described generally as a gel. The gel will typically have properties including an ability to "flow" which approaches that of a fluid. Particularly in the vicinity of any opening or slit 45 extending through the access device 34, propagation of the opening may be of concern. Stresses resulting from the presence of an instrument will be concentrated at the ends of such an opening or slit. For this reason, a good tear resistance is desired for the gel material. Such a tear resistance is often inherent in the KRATON/oil mixtures and may be enhanced by encapsulating the gel in other materials. For example, a low tear resistant gel could be encapsulated in a urethane sheath to improve the tear resistant qualities of the resulting products. Such a sheath need not be elastic but could be comprised, for example, of overlapping sheets of a non-elastic material.

Any of the gel materials contemplated could be modified to achieve different properties such as enhanced lubricity, appearance, and wound protection, or to provide anti-cancer or anti-microbial activity. Additives can be incorporated directly into the gel, for example in the case of pharmaceuticals, or applied as a surface treatment to the gel, for example, to improve lubricity or appearance. Other compounds could be added to the gel to modify its physical properties or to assist in subsequent modification of the surface by providing bonding sites or a surface charge. Antioxidants and antirads can be added to the mixture to extend the shelf life of the finished product or increase its ability to withstand radiation sterilization.

Sealing materials used in medical access devices of the past have been chosen primarily for their durometer and elongation. It is these properties which measure the ability of the material to move into small spaces and crevices as may be required to form an instrument seal across the working channel of a trocar. For example, in the past, a silicone mixture was used in medical valves. This mixture had the following properties: an ultimate elongation less than about 1000 percent and a durometer not less than about 5 Shore A.

These properties of the prior art materials are far exceeded by the properties associated with the present invention which in some respects provide a full magnitude of advantage. In fact, the difference between the materials of the prior art and the materials of the present invention are sufficiently substantial, that it is perhaps misleading to refer to the present material as merely a gel. According, the material of the present invention, having properties including an ultimate elongation greater than about 1000 percent and a durometer less than about 5 Shore A, will be referred to herein as an "ultragel."

In a preferred embodiment of the present invention, the ultragel includes KRATON and mineral oil and provides a sealing material with the following properties: an ultimate elongation exceeding about 1500 percent, and a durometer of less than about 200 Bloom. The durometer in this case is considerably lower than that of the prior art materials. In fact, the durometer of the present material is so soft it cannot even be measured on the Shore A scale.

The resulting elongation and durometer of the present material facilitates its use with as an access valve which is capable of forming seals with a full range of instrument sizes,

but is also capable of functioning as a zero seal. Whereas access devices of the prior art may have required as many as six separate seals in order to accommodate a full range of instrument sizes, access devices can now be made with only a single valve formed of the ultragel material.

In a typical manufacturing process, the KRATON G1651 is mixed with the mineral oil in a ratio by weight of 1 to 9. In order to manufacture this material, the combination is heated to a temperature of about 200° centigrade. In a preferred method of manufacturing, the mold is provided with a circumferential ring insert which is molded into the gel, and slit inserts which can be removed from the gel to form the opening or slit 45. The resulting gel can be coated with cornstarch to reduce tack and cooled at room temperature.

Many of the properties of the KRATON/oil mixture will vary with adjustments in the weight ratio of the components. In general, the greater the percentage of mineral oil, the more fluid the mixture; the greater the percentage of KRATON, the more rigid the material. Weight ratios of KRATON to oil as low as 1 to 5 have been contemplated for a more rigid structure. As the KRATON/oil weight ratio approaches 1 to 10, the mixture becomes more liquid. Ratios as high as 1 to 15 have been contemplated for this invention.

The processing temperature can also vary considerably as it is primarily dependent on the type of KRATON used. Temperatures in a range of about 150° centigrade to about 250° centigrade have been contemplated.

With an appreciation that these ratios and temperatures can develop considerably different properties, it is now apparent that these materials can be layered to provide generally different properties within each layer. For example, an outer layer might be formed of a KRATON/oil mixture having more rigid properties, thereby providing the pad 35 with an outer layer that is more rigid. After that layer is at least partially cured, another layer of the material can be poured inside of the outer layer. This second layer might be softer providing the pad 35 with the significant sealing properties. It has been found that successive layers will tend to fuse slightly at their interface, but will generally maintain their separate identities. Additional layers could be added to provide a progression of properties in a particular device.

Having discussed the properties desirable for the gel material, and the process of manufacture, one can now address the other embodiments of the concept which may provide additional advantages for particular surgical procedures. An embodiment of the access device 34, shown in its operative position in FIG. 6, is illustrated by itself in the axial cross section view of FIG. 8.

This same embodiment can be reinforced with o-rings 61 and 63 as illustrated in FIG. 9 where elements of structure are designated by the same reference number followed by the lower case letter "b." Providing these o-rings 61 and 63 may facilitate several functions associated with the access device 34b. For example, the rings 61, 63 will typically aid in maintaining a radial sealing pressure on all sides of the opening 45b. The rings 61 and 63 will also tend to maintain the flanges 54b and 56b respectively, in their generally planar configurations. This further ensures that the flanges 54, 56 will not collapse into the incision 32 with the insertion or withdrawal of an instrument, such as the surgeon's hand 17. Of course, the o-rings 61 and 63 must be sufficiently large to accommodate the instrument during insertion and removal.

A further embodiment of the invention is illustrated in FIG. 10, where elements of structure are similar to those previously disclosed are designated with the same reference numerals followed by the lower case letter "c." This embodiment includes the pad 35c with the opening or slit 45c. The

external perimeter o-ring 61c is inserted molded into the circumference of the pad 35c. The internal o-ring 63c is coupled to the pad 35c, for example, by way of attachment to the o-ring 61c for example, by a membrane 65. In this case, the membrane 65 has a generally cylindrical configuration and elastomeric properties. In preferred embodiments, the membrane 65 is formed of urethane, neoprene or isoprene.

When the embodiment of FIG. 10 is being operatively positioned, the internal o-ring 63b is initially gathered and inserted through the incision 32 (FIG. 2). The pad 35c and external o-ring 61c are left outside the incision 32 so that the only material extending across the incision 32 is the membrane 65. It will be noted that in this case, the working channel 36c is formed by the slit 45c, the cylindrical membrane 65, and the internal o-ring 63b.

In this particular embodiment, the pad 35c functions generally as described with reference to FIG. 2. The primary seal between the pad 35c and the abdominal wall 21 can be formed either with a circumferential ring, such as the adhesive ring 52c, or by relying on the sealing characteristics of the insufflation gas against the internal o-ring 63b and membrane 65.

This embodiment of FIG. 10 is of particular advantage as it incorporates the pad 35c in perhaps its simplest configuration, while providing a primary seal between the device 34c and the abdominal wall 21 which is facilitated by the insufflation pressure. Furthermore, the membrane 65 enhances the sealing characteristics of the device 34c, and provides a lining for the incision 32. With the membrane 65, the incision 32 need not be stretched to a diameter greater than that required by any instrument inserted through the working channel 36c.

A further embodiment of the invention is illustrated in FIG. 11 where elements of structure similar to those previously disclosed are designated with the same reference numeral followed by the lower case letter "d." This embodiment is similar to that of FIG. 8 in that it includes the pad 35d, slit 45d, exterior flange 54d, and internal flange 56d. The embodiment of FIG. 11 differs from that of FIG. 8 in that it includes a lead-in cavity 70 which is in communication with the slit 45d.

In a preferred embodiment, this cavity 70 is sized and configured to receive the arm 16 of the surgeon 14 in a manner illustrated in FIG. 7. In this case, the slit 45d would function primarily to maintain a zero seal, while the portions of the pad 35d or flange 54d which form the cavity 70 would function primarily to form the instrument seal.

A further embodiment of the invention is illustrated in the plan view of FIG. 12 and the cross section views of FIGS. 13 and 14. In this embodiment, elements of structure similar to those previously discussed are designated with the same reference numeral followed by the lower case letter "e." In this case, the lead-in cavity has the general shape of a cylinder 72 with an axis that is collinear with the axis 47e of the pad 35e.

As perhaps best illustrated in FIG. 13, the slit 45e has a trapezoidal configuration. Thus, it begins proximally with a narrow length which may generally be equivalent to the diameter of the cylinder 32. From the cavity 70e, the length of the slit 45e increases with progressive positions distally through the pad 35e. In the illustrated embodiment, the trapezoidal slit 45e is formed as the frustum of an isosceles triangle.

A further embodiment of the invention is illustrated in FIGS. 15 and 16 wherein elements of structure similar to those previously described are designated with the same reference numeral followed by the lower case letter "f." As previously discussed with reference to FIG. 12, this embodiment of the pad 35f is formed with a proximal surface 71 and a distal surface 73. The pad 35f also includes the coaxial lead-in cylinder 72f and the trapezoidal slit 45f. However, in this case, a duck-bill valve 74 is provided to further enhance

the characteristics of the zero seal. As illustrated, the working channel 36f is formed by the lead-in cavity 70f, the slit 45f, and an extension of the slit 45f which is defined by the duck-bill valve 74f.

The duck-bill valve 72 can be formed with opposing flanges 76 and 78 which extend distally of the distal surface 73. When operatively disposed, the pad 35f can be positioned with its distal surface 73 against the exterior surface of the abdominal wall 21 (FIG. 2) and with the flanges 76 and 78 extending into the incision 32. With this configuration and operative disposition, the abdominal wall 21 at the incision 32 will produce opposing forces on the flanges 76 and 78 which tend to close the slit 45f, particularly in the absence of an instrument. In this manner, the duck-bill valve 74 can be relied on to enhance the characteristics of the zero seal.

A further embodiment of the invention is illustrated in FIG. 17 and 18 wherein elements of structure similar to those previously discussed are designated by the same reference numeral followed by the lower case letter "g." In this embodiment of the access device 34g, the pad 35g can be formed generally as discussed with reference to FIG. 13. In this embodiment, however, the pad 35g can be enclosed along its sides and the distal surface 73g, by a base 81. In this case, the pad 35g might be formed by the highly elastic material previously discussed, while the base 81 might be formed of a more rigid but nevertheless flexible material such as a urethane. With this configuration, the duck-bill valve 74f would be structured to extend distally of a distal surface 83 associated with the base 81. This would enable the duck-bill valve 74f to be formed of the base material rather than the super-elastic material. This might also improve the zero seal characteristics for particular operative applications.

Another simplified form of the invention is illustrated in FIGS. 19 and 20, where elements of structure similar to those previously discussed or designated with the same reference numeral followed by the lower case letter "h." The lead-in cavity 78h, in this case, is formed as an inverted cone 77 having its base at the proximal surface 71h and its apex in proximity to the distal surface 73h. Thus, the lead-in cavity 70h has an area in radial cross section which decreases with progressive positions distally through the pad 35h. In this embodiment, the proximal regions near the base of the cone 87 form the instrument seal, while the distal regions at the apex of the cone form the zero seal. The conical configuration of the lead-in cavity 70h also tends to funnel an instrument into the opening 45h leading distally to the apex of the cone 87.

It will be appreciated generally, that the slit 45 and lead-in cavity 70 can be provided with many different individual and cooperative configurations. By way of example, perhaps the simplest form for the pad 35 is illustrated in the embodiment of FIGS. 21 and 22 wherein elements of structure similar to those previously described are designated by the same reference numeral followed by the lower case letter "j." In this embodiment, the pad 35j with its proximal surface 71j and distal surface 73j, is provided with a simple trapezoidal slit 45j. In this case, the slit 45j extends between the proximal surface 71j and the distal surface 73j.

The slit 45j in this embodiment of FIG. 21 is typical of many structures which will define the slit 45j with a planar configuration. In such a case, the portions of the pad 35j which form the slit will comprise opposing planar surfaces such as those designated by the reference numerals 90 and 92 in FIG. 22.

It will be apparent that the slit 45 need not be formed by opposing surfaces having a planar configuration. Nevertheless, these opposing surfaces need to be capable of coming

into sealing contact with each other in order to establish the zero seal. Other slit configurations capable of accomplishing this function, may offer further advantages in particular procedures. Other examples of slit configurations are illustrated merely by way of example in FIGS. 23-26.

The embodiment of FIG. 23 is similar to that of FIG. 22 in that the opening 45j comprises a single slit which extends from the proximal surface 71j to the distal surface 73j. In the case of the FIG. 22 embodiment, the axis 47j is disposed within the plane of the slit 45j. In the case of the FIG. 23 embodiment, the plane of the slit 45j does not include the axis 47j. Rather, the slit 45j is formed in a plane which has an angular relationship with the axis 47j, the proximal surface 71j, as well as the distal surface 73j. This construction enables the slit 45j to have a length greater than the thickness of the pad 35j.

In the embodiment of FIG. 24, elements of structure similar to those previously discussed are designated with the same reference numeral followed by the lower case letter "k." In this case, the opening 45k is configured as two slits 94 and 96 formed in individual planes that are angularly spaced with respect to each other. Of course, two or more of the planar slits 94 and 96 may be equally angularly spaced around the axis 47k. In one embodiment, the individual planar slits 94 and 96 intersect at the axis 47k. Alternatively, the slits 94 and 96 may be axially spaced in order to facilitate formation of the instrument seal.

In the embodiment of FIG. 25, elements of structure similar to those previously discussed are designated with the same reference numeral followed by the lower case letter "m." In this embodiment, the opening 45m is defined as a slit 98 having a curved rather than planar configuration. In the illustrated embodiment, the curved slit 98 is formed as a spiral around the axis 47m. Along the axis 47m, the opposing surfaces forming the spiral slit 98 can "flow" into sealing proximity in order to produce the zero seal.

FIG. 26 illustrates a similar embodiment including a spiral slit. In this figure, elements of structure similar to those previously discussed are designated by the same reference numeral followed by the lower case letter "n." The spiral slit 98n in this embodiment is also formed around the axis 47n of the pad 35n, but in this case the portions forming the slit 98n do not extend completely to the axis 47n. As a result, an axial channel 100 is formed at least partially along the axis 47n. This channel 100 can function in a manner similar to the lead-in cavity 70 discussed with reference to FIGS. 11-12. This channel 100 can even be formed with a conical configuration similar to that discussed with reference to FIG. 19.

In an embodiment where the channel 100 is left open, a zero seal might be provided by positioning a septum valve across the channel 100. Such an embodiment is illustrated in FIG. 27, wherein the septum valve is designated with a reference numeral 101 and the other elements of structure similar to those previously discussed are designated with the same reference numerals followed by the lower case letter "p." Thus the embodiment of FIG. 27 includes the spiral slit 98p, the pad 35p, and the axis 47p. This embodiment of FIG. 27 is merely representative of many other embodiments that will combine a slit, such as the slit 98p, with other valve structures, such as the septum valve 101.

Other curved slit configurations would include embodiments wherein the slit is curved, sinusoidal, or S-shaped in a side elevation view. Such configurations provide a slit part having a length greater than the thickness of the pad. Normally, the more circuitous the slit path, the better the sealing characteristics.

A further and more complex configuration for the opening 45 is illustrated in the embodiment of FIG. 28 wherein elements of structure similar to those previously disclosed are designated with the same reference numeral followed by the lower case letter "q." This embodiment is representative of many other complex embodiments which can be formed with intricate shapes and different materials in order to accomplish the desirable function of forming, with a single valve, a zero seal as well as an instrument capable of accommodating a full range of instrument sizes. In the embodiment of FIG. 28, the pad 35q is formed with a base 110 which is disposed circumferentially of a core 112. In this case, the core 112 is formed of the superelastic material or gel and provided with the shape of the cone 87q as discussed with reference to FIGS. 19 and 20. The base 110 is formed from a material that may not be elastic, but preferably is flexible. In the preferred embodiment, the base 110 is formed of a urethane.

In this construction, the base 110 is provided with a plurality of spokes 114 each of which extends radially inwardly from a base 116 to a tip 118. The core 112 extends from the axis 47q outwardly to the tips 118 of the spokes 114. In the illustrated embodiment, the core 112 has fingers 121 which extend beyond the tips 118 and toward the bases 116 between each adjacent pair of the spokes 114. These fingers 121 extend radially outwardly to an end surface 123 which stops short of the base 116 leaving a void 125 therebetween.

The voids 125 are of particular interest to this embodiment and can be incorporated into any of the embodiments previously discussed. Such voids 125 provide a space or absence of material into which the highly elastic material, such as that of the fingers 121, can expand during insertion of an instrument such as the arm 16 (FIG. 7). Since the gel material is almost fluid in its properties, the voids 125 permit expansion of the gel with very little resistance. Voids, such as the voids 125 in the embodiment of FIG. 28, can be defined solely in the gel material or between the gel material and any other base material.

In the case of FIG. 28, the spokes 114 and fingers 121 are defined generally in planes which are parallel to the axis 47q. Similar fingers, illustrated in the embodiment of FIG. 31 are defined generally in a plane which is perpendicular to the axis. In this embodiment, elements of structure similar to those previously disclosed are designated by the same reference numeral followed by the lower case letter "r." As illustrated, the pad 35r can be formed with a relatively large opening 45r having the configuration of a coaxial cylinder 130. A plurality of fingers or flaps 132 extend into the opening 45r and tend to form a lead-in cavity 70r with properties such as those discussed with reference to FIG. 19. In this case, the annular flaps 132 have a conical configuration extending from a base 134 to an apex 136. It will be noted that the areas between the flaps 132, form voids 125r into which the flaps 132 can be displaced upon insertion of an instrument, such as the arm 16.

A further embodiment of the invention is illustrated in FIG. 32 where elements of structure similar to those previously disclosed are designated with the same reference numeral followed by the lower case letter "s." This exploded view of the access device 34s includes not only the pad 35s but also a complimentary structure for maintaining the position of the pad 35s, for forming a seal between the pad 35s and the abdominal wall 21, and for dilating the incision 32 to a variable extent as required by the surgeon 14. In this case, the access device 34s includes three components, a jell cap 143, base 145, and a retraction sheath 147.

The gel cap 143 includes not only the gel pad 35s, but also a circumferential cap ring 154 which can be inserted and

molded to the pad 35s. The resulting gel cap 143 forms a seal with the base 145, thereby defining the working channel 36s through the pad 35s, the cap ring 154, the base 145, and the retraction sheath 147. In the manner previously discussed, this working channel 36s includes the single valve formed by the gel pad 35s which provides both a zero seal and an instrument seal for a wide range of instrument diameters.

The structure associated with the gel cap 143 is described in greater detail with reference to FIGS. 33 and 34. In the plan view of FIG. 33, it can be seen that this embodiment includes the gel pad 35s centrally disposed within the circumferential cap ring 154. Holding tabs 156 can be provided to extend radially outwardly of the cap ring 154. These holding tabs 156 can facilitate the sealing engagement of the gel cap 143 with the base 145 in the manner described in greater detail below.

The gel pad 35s can be formed of any of the materials previously discussed although the preferred embodiment includes the KRATON/mineral oil gel. The cap ring 154 for such an embodiment can be advantageously formed of KRATON only. This will make the cap ring 154 more rigid than the gel pad 35s while maintaining an excellent material interface between the pad 35s and the ring 154. In a typical manufacturing operation, the cap ring will be pre-disposed in the mold for the gel pad 35s with the unitary structure of the gel cap 143 resulting.

The cross section view of FIG. 34 shows the gel cap 143s and illustrates an annular void 158 formed on the inner circumference of the cap ring 154. This void 158 is of particular advantage in forming a sealing relationship with the base 145 in the manner discussed in greater detail below.

The base 145 of this embodiment is shown in greater detail in the plan and cross section of views of FIGS. 34 and 35, respectively. From these views it will be noted that the base 145 can be provided with a smooth generally cylindrical inner surface 161 which extends proximally to a rounded end surface 163 and outwardly from the end surface 163 along an annular lip 165. A plurality of tabs 167 can be equally spaced to extend outwardly and distally around the circumference of the lip 165.

Distally of the inner surface 163, an annular flange 170 can be provided with an annular projection 172 sized and configured to form the desired sealing relationship between the gel cap 143 and the base 145. The process of molding the base 145 can be facilitated by forming the base as two separate components divided, for example, by a dotted line 174 in FIG. 35. In a preferred embodiment, the base 145 is molded from a polycarbonate material.

A preferred embodiment of the retracting sheath 147 is illustrated in FIG. 37. In this view it can be seen that the retraction sheath 147 includes a tubular wall 175 which has the configuration of the frustum of a cone 176 at its distal end and the configuration of a cylinder 177 at its proximal end. A flexible retaining ring 152 terminates the distal end while a fold 154 is formed at the proximal end. The tubular wall 175 is illustrated to include an outer surface 180 and an inner surface 181. In a preferred embodiment, the sheath 147 is formed of an elastomer, such as neoprene, so its frustule conical and cylindrical configurations exist primarily in the natural unstretched state.

As the sheath 147 is stretched axially, the diameter of the cylindrical proximal end increases thereby placing radial forces on the incision 32. The more the sheath 147 is stretched axially, the greater becomes the diameter of the sheath and consequently the larger becomes the opening through the incision 32. This feature is of particular advantage as it permits the surgeon to define the size of the incision 32 with an appropriate degree of axial tension on the sheath 147. By

maintaining this tension, the preferred size of the incision 132 is maintained throughout the operation. In a preferred apparatus and method, the axial tension is maintained by stretching the sheath 147 over the tabs 167 (FIG. 34) of the base 145. Indicia 182 can be printed on the sheath 147 to provide an indication of the relationship between the axial stretch of the sheath 147 and the size of the incision 32.

The fold 153 is provided to facilitate a grip on the proximal end of the sheath 147. This fold 153 can also function to provide reinforcement where the walls of the sheath 147 engage the tabs 167 of the base 145. In the embodiment illustrated in FIG. 38 additional folds 184, 186 are provided at spaced axial locations, such as those defined by the indicia 182 in FIG. 37. With these folds 184 and 186, additional points of reinforcement are provided to engage the tabs 167 while providing the sheath 147 with predetermined degrees of axial stretch associated with different sizes of the incision 32.

The method of using the embodiment of FIG. 32 is illustrated the progressive use of FIGS. 39-42. In FIG. 39, a top plan view of the abdominal wall 21 of the patient 10 is illustrated with a template 195 positioned to facilitate location of the incision 32. The size of the incision 32 can be determined with the indicia 182 on the template 195 showing, for example, multiple lengths of a line 197, each length being equated with a glove size for the surgeon's hand 17 (FIG. 7). Knowing his/her glove size, the surgeon will merely cut the incision in accordance with an appropriate length of the line 197. The longer lengths of the line 197 are associated with the larger incisions, the larger glove sizes and accordingly the larger hands 17. After the incision 32 has been cut along the line 197, the template 195 can be removed.

As illustrated in FIG. 40, the retraction sheath 147 can then be mounted through the incision 32. Initially the ring 152 is compressed and fed through the incision 32. On the inner surface of the abdominal wall 21, the ring 152 is free to expand to its larger diameter, as shown by a dotted line 158 in FIG. 40. The portions of the wall 176 which define the cylinder 177 are left to extend proximally through the opening 32 as shown in FIG. 40.

Prior to or after inserting the sheath 147, the base 145 can be disposed around the incision 32. Then the exposed portions of the sheath 147 will extend through the incision 32 and within the circumferential base 145. As illustrated in FIG. 41, the wall 176 of the sheath 147 can then be drawn proximally, outwardly of the page in FIG. 41, to axially stretch the sheath 147. As noted, when the sheath 147 is axially stretched, it will create radial forces on the abdominal wall 21 which will tend to enlarge the incision 32. The greater the axial stretch, the larger the incision 32.

When the incision 32 has the desired size, the stretched sheath 147 can be drawn over the tabs 167 to maintain the axial stretch and the desired size for the incision 32. Either the indicia 182, as shown in FIG. 36, or the additional folds 184 and 186 as shown in FIG. 37, can be aligned with the tabs 167 to provide a predetermined size for the incision 32. At this point, the seal between the abdominal wall 21, the sheath 147, and the base 145 is fully established.

A final step remaining in this process is the attachment of the gel cap 143 to the base 145. This is accomplished as illustrated in FIG. 36 by capturing the lip 172 of the base 145 in the annular void 158 of the gel cap 143. Bending the holding tabs 156 upwardly and outwardly facilitates this engagement which ultimately forms a seal between the base 145 and the gel cap 143.

Although this invention has been disclosed with reference to certain structural configurations, it will be appreciated that these products are merely representative of many different embodiments of the invention. Accordingly, one is cautioned not to limit the concept only to the disclosed embodiments,

but rather encouraged to determine the scope of the invention only with reference to the following claims.

The invention claimed is:

1. A surgical access device for laparoscopic surgical procedures in which the abdominal cavity of a patient is pressurized with an insufflation gas, the access device adapted for disposition relative to an incision in a body wall of a patient, the access device facilitating insertion of an instrument through the access device and through the incision in the body wall of the patient, the access device configured for maintaining a seal with the instrument extending therethrough, and the access device configured for coupling to the body wall, thereby maintaining a sealing relationship therewith, the surgical access device comprising:

a valve comprising a first, outer layer and a second, access layer, wherein the first, outer layer comprises a proximal surface and a distal surface, and the second, access layer comprises a proximal surface and a distal surface; a fist access channel positioned in the first, outer layer between the proximal and distal surfaces thereof; and a second access channel positioned in the second, access layer between the proximal and distal surfaces thereof, the second access channel being at least partially aligned with the first access channel,

wherein

the first, outer layer comprises a gel pad comprising an elastomeric gel material, and the second, access layer comprises a flexible material;

the second, access layer is coupled to, and at least partially supports the gel pad;

the valve is dimensioned and configured for coupling to a body wall during use, thereby substantially maintaining a sealing relationship therewith; and

the valve has a first state, in which at least the first, outer layer of the valve forms an instrument seal with an instrument extending through the first and second access channels, and a second state, in which at least the first, outer layer of the valve forms a seal in the absence of any instrument extending through the first and second access channels; and

the valve is adapted to accommodate a range of instrument sizes from about the size of a guidewire to about the size of a surgeon's arm.

2. The surgical access device of claim 1, wherein the thickness of the first, outer layer is greater than the thickness of the second, access layer.

3. The surgical access device of claim 2, wherein the second, access layer is of substantially uniform thickness.

4. The surgical access device of claim 1, wherein the first, outer layer and the second, access layer are of the same material.

5. The surgical access device of claim 1, wherein the material properties of the first, outer layer are different from the material properties of the second, access layer.

6. The surgical access device of claim 5, wherein the second, access layer comprises a flexible material more rigid than the elastomeric material of the first, outer layer.

7. The surgical access device of claim 6, wherein the material of the second, access layer being urethane.

8. The surgical access device of claim 1, wherein the first access channel defines a first slit and the second access channel defines a second slit, the second slit being aligned with the first slit.

9. The surgical access device of claim 1, wherein the elastomeric gel material of the first, outer layer comprises a thermoplastic gel material.

10. The surgical access device of claim 9, wherein the thermoplastic gel material comprises a tri-block copolymer.

11. The surgical access device of claim 10, wherein the tri-block copolymer being selected from one of styrene-ethylene/butylene-styrene, styrene-isoprene-styrene, styrene-butadiene-styrene, and styrene-ethylene/propylene-styrene.

12. The surgical access device of claim 1, the second, access layer comprising a duck-bill valve positioned on a surface opposite the first, outer layer, the duck-bill valve being aligned with the second access channel, the second access channel extending through the duck-bill valve.

13. The surgical access device of claim 12, the duck-bill valve comprising a first flange and a second flange opposing the first flange, the first and second flanges extending from the second, access layer in a direction generally opposite to the first, outer layer, the second access channel extending between the first flange and the second flange.

14. A surgical access port for hand-assisted laparoscopic procedures in which the abdominal cavity of a patient is pressurized with an insufflation gas, the access port adapted to form a sealing relationship with a body wall of the patient, to receive an instrument extending through the access port and through an incision in the body wall, and to maintain a sealing relationship with the instrument and with the body wall, the surgical access port comprising:

a valve comprising a first, outer layer comprising a proximal surface and a distal surface; a second, access layer comprising a proximal surface and a distal surface, wherein the second, access layer at least partially supports the distal surface of the first, outer layer; and a duck-bill valve, wherein

the first, outer layer comprises a gel pad comprising a gel material, and

the valve is dimensioned and configured for coupling to and for forming a seal with a body wall of a patient;

a first access channel positioned in the first, outer layer between the proximal and distal surfaces thereof; and

a second access channel positioned in the second, access layer between the proximal and distal surfaces thereof, the second access channel being at least partially aligned with the first access channel;

wherein

the duck-bill valve is coupled to the distal surface of the second, access layer,

the duck-bill valve comprises a first flange and a second flange opposing the first flange, the first and second flanges extending from the distal surface of the second, access layer,

the duck-bill valve is at least partially aligned with the second access channel,

the valve has a first state, in which at least the first, outer layer of the valve forms a seal with an instrument extending through the first and second access channels, and a second state in which at least the first, outer layer of the valve forms a seal in the absence of any instrument extending through the first and second access channels, and

the valve is adapted to accommodate a range of instrument sizes from about five millimeters in diameter to about three inches in diameter.

15. The surgical access device of claim 14, wherein the first, outer layer and the second, access layer are of the same material.

16. The surgical access device of claim 14, wherein the material properties of the first, outer layer are different from the material properties of the second, access layer.

17. The surgical access device of claim 16, wherein the second, access layer comprises a flexible material more rigid than the elastomeric material of the first, outer layer.

18. The surgical access device of claim 17, wherein the material of the second, access layer being urethane.

19. The surgical access device of claim 14, wherein the first access channel defines a first slit and the second access channel defines a second slit, the second slit being aligned with the first slit.

20. The surgical access device of claim 14, wherein the tri-block copolymer being selected from one of styrene-ethylene/butylene-styrene, styrene-isoprene-styrene, styrene-butadiene-styrene, and styrene-ethylene/propylene-styrene.

21. A medical access port, the access port adapted to form a seal with a body wall of a patient, to receive an instrument extending through the port and through an incision in the body wall of the patient, and to maintain a sealing relationship with the instrument and with the body wall, the medical access port comprising:

a gel pad having a first, proximal surface and a second, distal surface, and comprising an elastomeric gel material;

a first access channel positioned through the gel pad between the proximal surface and the distal surface;

a base layer comprising a flexible material, wherein the base layer at least partially supports the gel pad;

a second access channel extending through the base layer, wherein at least a portion of the second access channel is in communication with at least a portion of the first access channel;

wherein the access port is dimensioned and configured to contact with and to form a seal with of a patient,

wherein the gel pad, in a first state, is dimensioned and configured for forming a seal with an instrument extending through the gel pad and the base layer, and, in a second state, the gel pad forms a seal in the absence of any instrument extending through the gel pad and the base layer, and

wherein the gel pad is adapted to accommodate and to form a seal with an instrument from about the size of a guidewire to about the size of a surgeon's hand.

22. The medical access device of claim 21, wherein the access channel defines a slit.

23. The medical access device of claim 21, wherein the elastomeric gel material of the gel pad comprises a thermoplastic gel material.

24. The medical access device of claim 23, wherein the thermoplastic gel material comprises a tri-block copolymer.

25. The medical access device of claim 24, wherein the tri-block copolymer being selected from one of styrene-ethylene/butylene-styrene, styrene-isoprene-styrene, styrene-butadiene-styrene, and styrene-ethylene/propylene-styrene.

26. The medical access device of claim 21, wherein the gel pad and the base layer are of the same material.

27. The medical access device of claim 21, wherein the material properties of the gel pad are different from the material properties of the base layer.

28. The medical access device of claim 27, wherein the base layer comprises a flexible material more rigid than the elastomeric material of the gel pad.

29. The medical access device of claim 28, wherein the material of the base layer is urethane.

30. The medical access device of claim 21, wherein the first access channel defines a first slit and the second access channel defines a second slit, the second slit being at least partially aligned with the first slit.

* * * * *

专利名称(译)	手术进入装置和方法		
公开(公告)号	US7481765	公开(公告)日	2009-01-27
申请号	US11/244647	申请日	2005-10-05
[标]申请(专利权)人(译)	应用医疗资源		
申请(专利权)人(译)	应用医疗资源CORPORATION		
当前申请(专利权)人(译)	应用医疗资源CORPORATION		
[标]发明人	EWERS RICHARD C BRUSTAD JOHN R PINGLETON EDWARD D HILAL NABIL DULAK GARY R ADLPARVAR PAYAM BOWES ROBERT R		
发明人	EWERS, RICHARD C. BRUSTAD, JOHN R. PINGLETON, EDWARD D. HILAL, NABIL DULAK, GARY R. ADLPARVAR, PAYAM BOWES, ROBERT R.		
IPC分类号	A61B1/32 A61B19/00 A61B17/00 A61B17/02 A61B17/34		
CPC分类号	A61B17/0293 A61B17/3423 A61B17/3498 A61M13/003 A61B17/0218 A61B17/3474 A61B2017/00265 A61B2017/00526 A61B2017/3492 A61B2017/3445 A61B2017/3419		
助理审查员(译)	阮瞳V		
优先权	60/241958 2000-10-19 US PCT/US2001/029682 2001-09-21 WO		
其他公开文献	US20060030755A1		
外部链接	Espacenet USPTO		

摘要(译)

外科进入装置包括单个阀，该单个阀与主体壁形成密封并且提供进入体腔的进入通道。阀门具有在没有仪器和仪器密封的情况下产生零密封的特性。该阀可包括由弹性体和油组成的凝胶，其提供大于1000%的伸长率和小于5邵氏A的硬度。单个阀可用作手动端口，其中器械包括外科医生的手臂。制造外科进入装置的方法包括将胶凝剂与油混合，优选在模制过程中。使用该装置的方法包括用仪器创建开口。可以通过单个瓣膜从器官腔体移除器官以产生器官密封，同时器官在体腔外部被寻址。

