



US 20150133968A1

(19) **United States**
(12) **Patent Application Publication**
Einarsson

(10) **Pub. No.: US 2015/0133968 A1**
(43) **Pub. Date: May 14, 2015**

(54) **SUTURING DEVICE FOR LAPAROSCOPIC PROCEDURES**

Publication Classification

(71) Applicant: **Jon Einarsson**, Boston, MA (US)

(51) **Int. Cl.**
A61B 17/04 (2006.01)
A61B 17/062 (2006.01)

(72) Inventor: **Jon Einarsson**, Boston, MA (US)

(52) **U.S. Cl.**
CPC *A61B 17/0469* (2013.01); *A61B 17/0491* (2013.01); *A61B 17/0625* (2013.01); *A61B 17/0482* (2013.01); *A61B 2017/00805* (2013.01)

(21) Appl. No.: **14/397,682**

(22) PCT Filed: **Apr. 30, 2013**

(57) **ABSTRACT**

(86) PCT No.: **PCT/US13/38746**

§ 371 (c)(1),
(2) Date: **Oct. 29, 2014**

A suturing device includes an elongated body having an outer wall defining an interior space of the body, a shaft located in the interior space, and a needle mounted on a distal end of the shaft. The needle has a distal section transverse to a longitudinal axis of the shaft. The distal section of the needle terminates in a first jaw and a second jaw forming a forceps defining a piercing tip. The first jaw and second jaw have a grasping position wherein the first jaw and second jaw grasp a suturing material, and a release position wherein the first jaw and second jaw release the suturing material. After grasping the suturing material with the needle, the shaft rotates the needle to advance the needle and suturing material through tissue and mesh placed on the tissue. Spaced apart portions of the suturing material are then fused to create a suture.

Related U.S. Application Data

(60) Provisional application No. 61/641,069, filed on May 1, 2012.

Foreign Application Priority Data

May 1, 2012 (US) 61/641069

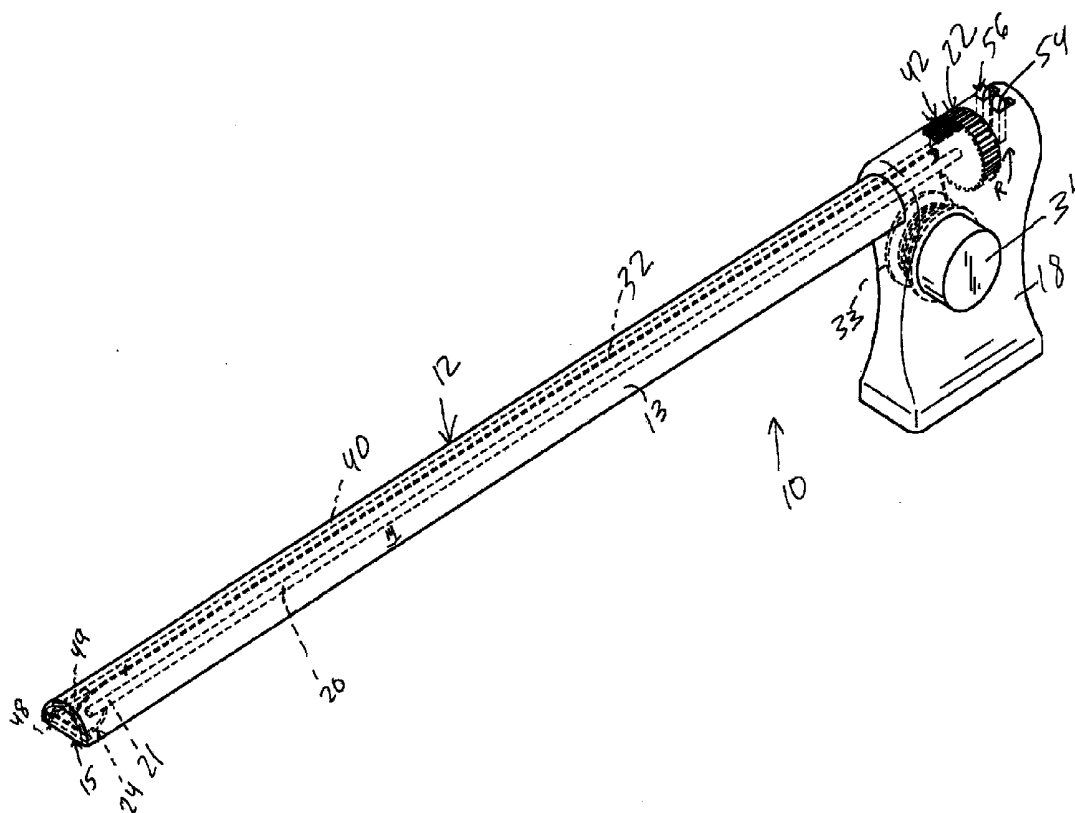

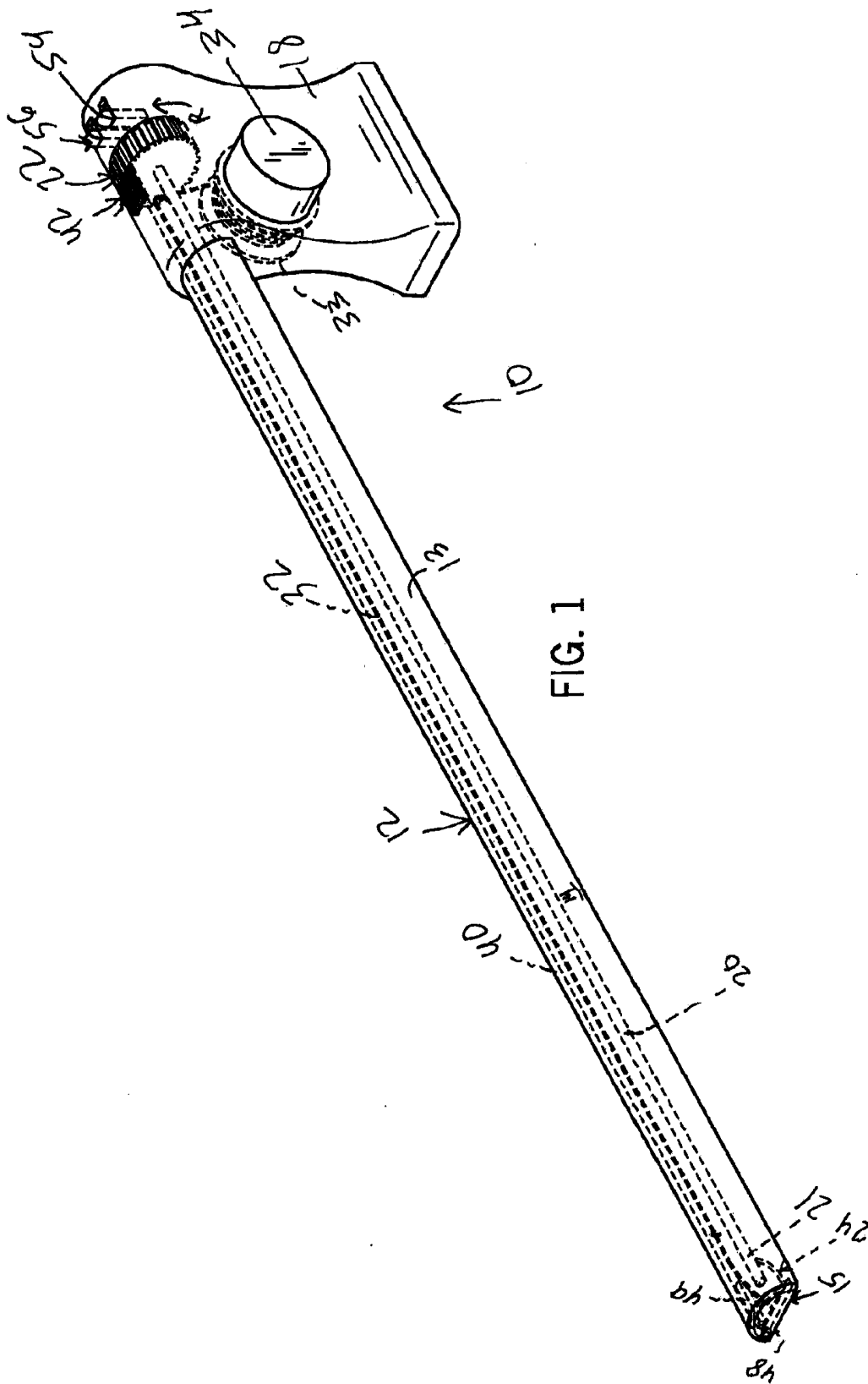

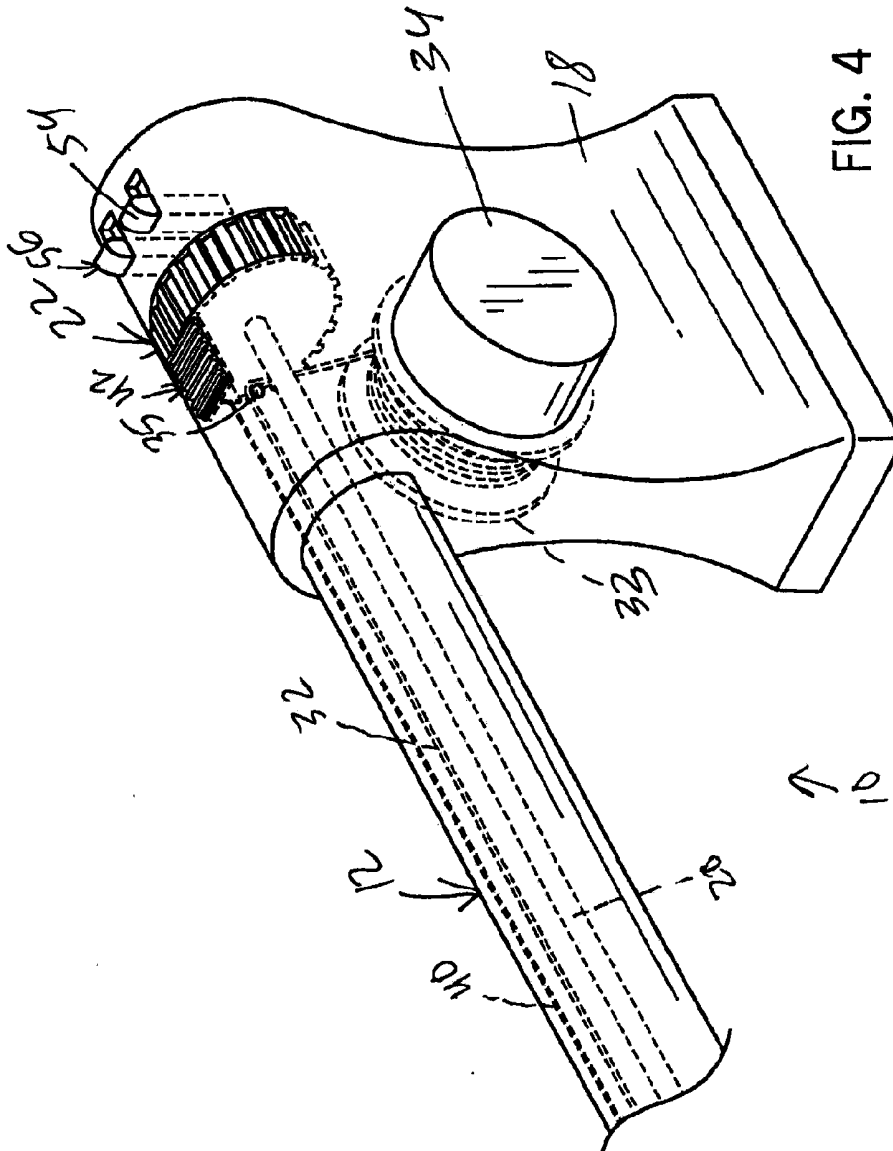

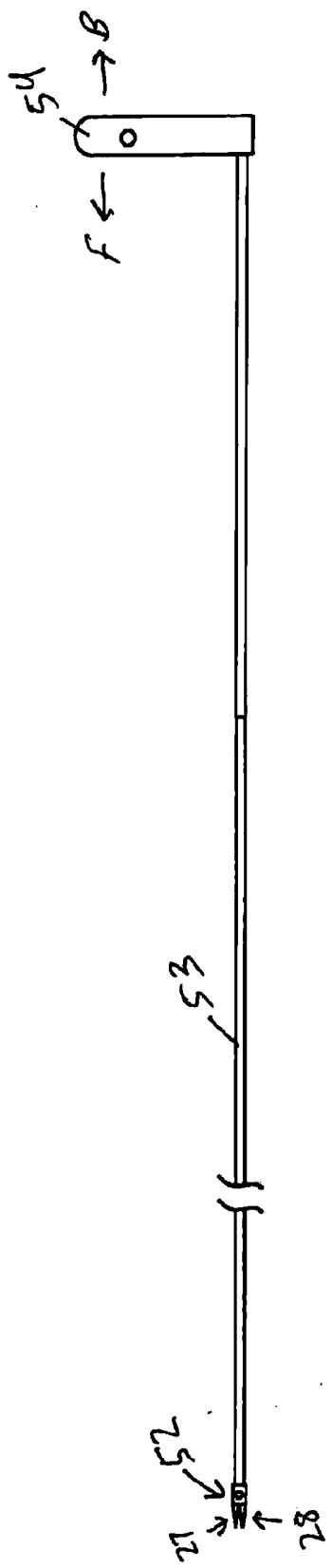

FIG. 5

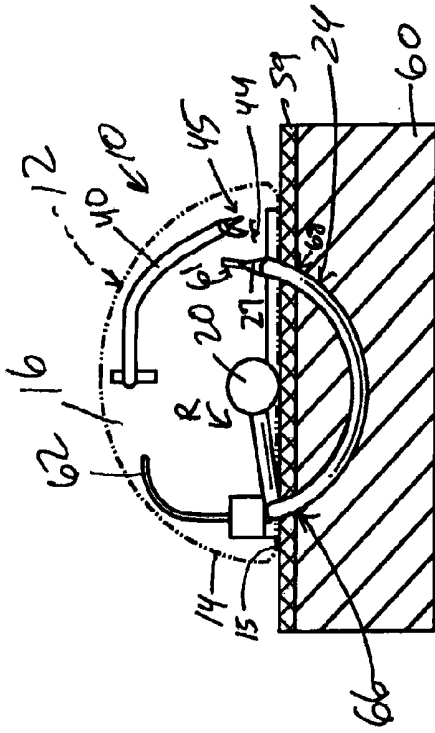

FIG. 6B

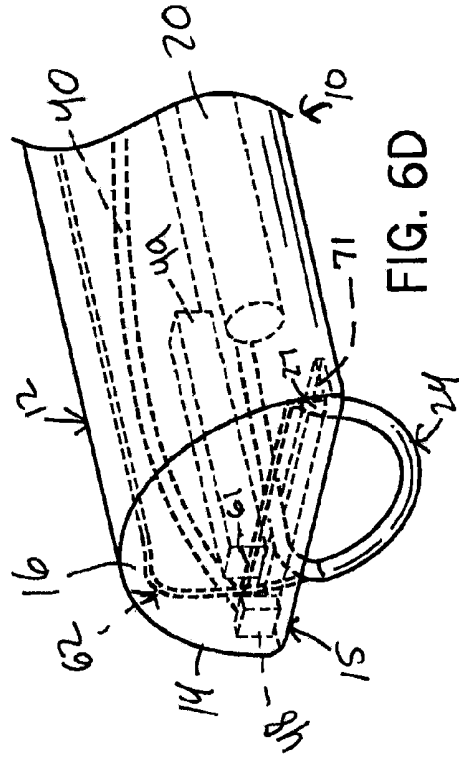

FIG. 6D

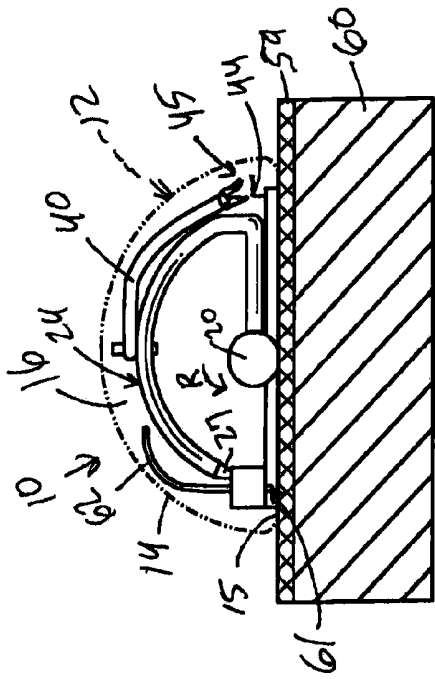

FIG. 6A

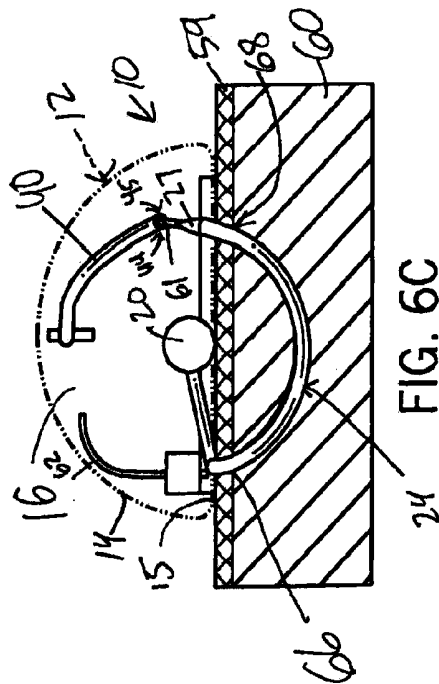

FIG. 6C

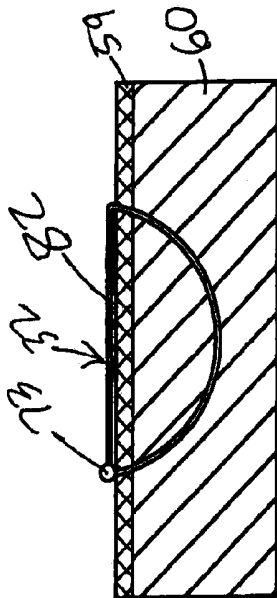

FIG. 6E

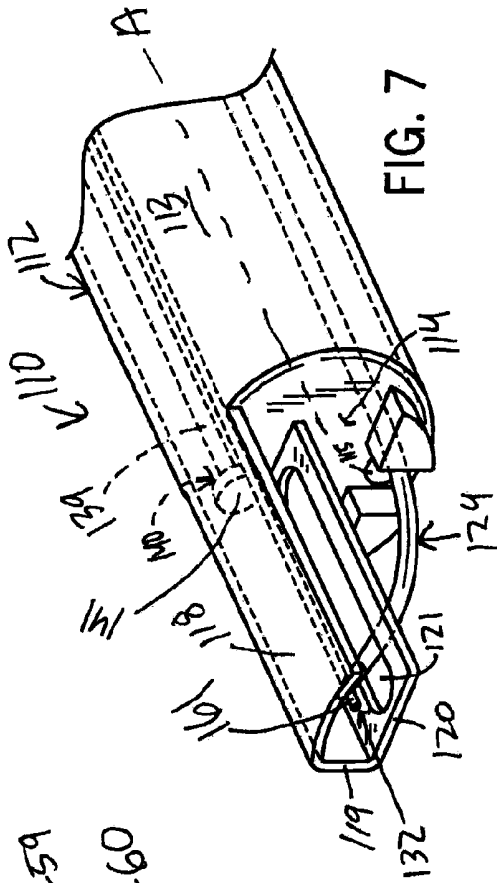

FIG. 7

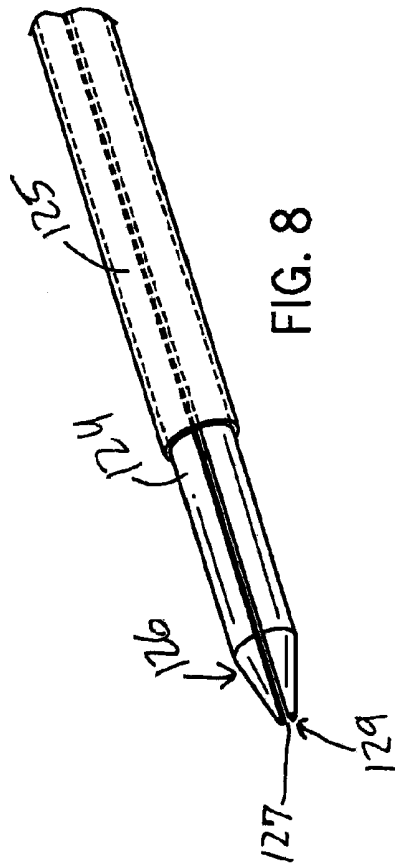

FIG. 8

SUTURING DEVICE FOR LAPAROSCOPIC PROCEDURES

CROSS-REFERENCE TO RELATED APPLICATIONS

[0001] This application claims priority from U.S. Patent Application No. 61/641,069 filed May 1, 2012.

STATEMENT REGARDING FEDERALLY SPONSORED RESEARCH

[0002] Not applicable.

FIELD OF THE INVENTION

[0003] The invention relates to a suturing device suitable for laparoscopic procedures. In one non-limiting example surgical use, the suturing device is used in performing laparoscopic sacrocolpopexy or sacrocervicopexy.

BACKGROUND OF THE INVENTION

[0004] Pelvic organ prolapse is a common medical condition, affecting almost half of women over the age of 50. (See, Subak et al., "Cost Of Pelvic Organ Prolapse Surgery In The United States", *Obstet Gynecol.* 2001;98(4):646-651.) As the population in the United States ages, there will be an increasing number of women who require treatment for this condition. This medical condition results in lifestyle restriction, social limitations, sexual dysfunction, and pain, but can also lead to more critical conditions such as urinary retention, urinary tract infection, and sepsis.

[0005] Laparoscopic sacrocolpopexy is the current gold standard for the surgical treatment of apical pelvic organ prolapse. (See, Ganatra et al., "The Current Status Of Laparoscopic Sacrocolpopexy: A Review", *Eur Urol.* 2009. See, also, U.S. Pat. No. 6,592,515 and PCT International Publication No. WO 2011/037837.) Interest in laparoscopic mesh placement has increased considerably in the current environment of mesh erosion that is associated with transvaginal placement of mesh.

[0006] Sacrocolpopexy suspends the apex of the vagina by affixing a Y-shaped piece of synthetic mesh to the anterior and posterior vaginal walls and suspending this from a strong ligament on the anterior part of the sacrum. This procedure is typically performed via a laparoscopic approach, entering the abdominal cavity to access the sacrum and vaginal tissues, both of which are retroperitoneal (behind the lining of the abdominal cavity). Tackers are not acceptable for use on the vagina, and laparoscopic mesh placement is quite challenging and requires advanced laparoscopic suturing skills in order to fasten the mesh.

[0007] Therefore, there is a need for a suturing device and associated method that can automate the process of fastening tissue and mesh laparoscopically and that enable a very rapid and secure fixation of mesh using a suturing material.

SUMMARY OF THE INVENTION

[0008] The present invention satisfies the foregoing needs by providing a suturing device for laparoscopic procedures. In one form, the device is comprised of a handle and a five millimeter shaft. At the end of the shaft, there is a needle that drives a fusible suture through the tissue and a loop is formed. A fusion device is then fired on the two ends of the suture loop which fastens the sutures together to form a knot. The suture

is also cut. The suture driving, knot forming and cutting are all done by manipulating features on the handle.

[0009] In one aspect of the invention, there is provided a device for suturing tissue in a patient. The suturing device includes an elongated body having an outer wall defining an interior space of the body, a rotatable shaft located in the interior space of the body, and a needle mounted on a distal end of the shaft. The needle has a distal section transverse to a longitudinal axis of the shaft. The distal section of the needle terminates in a first jaw and a second opposed jaw forming a forceps. At least one of the first jaw and the second jaw is movable relative to the other of the first jaw and the second jaw such that the first jaw and the second jaw have a grasping position in which the first jaw and the second jaw can grasp a suturing material and such that the first jaw and the second jaw have a release position in which the first jaw and the second jaw release the suturing material. The first jaw and the second jaw define a piercing tip of the needle when the first jaw and the second jaw are in the grasping position. In one form, the distal section of the needle is arcuate thereby forming a rotary needle. The suturing device can include a handle mounted to the elongated body, and the shaft can be fixed to a transverse disc shaped projection located on the handle for rotating the shaft.

[0010] The needle has a first position in which the piercing tip faces away from the interior space of the body, and the needle has a second position in which the piercing tip faces toward the interior space of the body. The rotary needle follows a curved path through tissue from the first position to the second position when the shaft is rotated about its longitudinal axis. The first jaw and the second jaw are in the grasping position thereby grasping the suturing material when the needle moves through tissue from the first position to the second position when the shaft is rotated about its longitudinal axis. The suturing material can be provided from a supply reel of suturing material, and a distal segment of suturing material is arranged in the interior space of the body such that the first jaw and the second jaw can grasp the suturing material when the needle is in the first position. The outer wall of the body can include a slot, and the needle passes through the slot when the needle moves from the first position to the second position when the shaft is rotated about its longitudinal axis.

[0011] The suturing device can further include a transfer arm located in the interior space of the body. The transfer arm terminates in a first holding member and a second opposed holding member. At least one of the first holding member and the second holding member is movable relative to the other of the first holding member and the second holding member such that the first holding member and the second holding member have a holding position in which the first holding member and the second holding member hold the suturing material and the first holding member and the second holding member have a disengaged position in which the first jaw and the second jaw disengage the suturing material.

[0012] The suturing device can further include an attachment device for securing together spaced apart portions of the suturing material thereby forming a closed length of the suturing material. In one form, the attachment device comprises a pair of heating elements movable between an open position in which the heating elements are spaced apart and a heat sealing position for contacting the spaced apart portions of the suturing material and heat sealing the spaced apart portions of the suturing material together.

[0013] The suturing material can be transferred from the first jaw and the second jaw of the needle to the first holding member and the second holding member of the transfer arm when the needle is in the second position, and the transfer arm can orient the spaced apart portions of the suturing material between the heating elements when the heating elements are in the open position. The heating elements are moved into the heat sealing position for contacting the spaced apart portions of the suturing material and heat sealing the spaced apart portions of the suturing material together.

[0014] In one form of the suturing device, a button is located on the handle of the suturing device, and a proximal end of the transfer arm is fixed to the button for moving the transfer arm. In another form of the suturing device, a first lever is located on the handle, and the first jaw and the second jaw are operatively coupled to the first lever such that movement of the first lever moves the first jaw and the second jaw between the grasping position and the release position. In yet another form of the suturing device, a second lever is located on the handle, and the first holding member and the second holding member are operatively coupled to the second lever such that movement of the second lever moves the first holding member and the second holding member between the holding position and the disengaged position.

[0015] In another aspect of the invention, there is provided method for suturing tissue in a patient. The method for suturing tissue uses a suturing device including an elongated body having an outer wall defining an interior space of the body, a rotatable shaft located in the interior space of the body, and a needle mounted on a distal end of the shaft. The needle has a distal section transverse to a longitudinal axis of the shaft, and the distal section of the needle terminates in a first jaw and a second opposed jaw. At least one of the first jaw and the second jaw is movable relative to the other of the first jaw and the second jaw. A leading portion of a length of suturing material is grasped within the interior space of the body with the first jaw and the second jaw of the needle such that the first jaw and the second jaw define a piercing tip, and the piercing tip is located near the tissue.

[0016] The shaft is rotated about its longitudinal axis thereby penetrating the tissue at an entry point of the tissue. The rotation of the shaft is continued until the leading portion of the length of suturing material has passed through the tissue and out of an exit point of the tissue. The leading portion of the length of suturing material is moved to a location near the entry point such that the leading portion of the length of suturing material is near or contacts a trailing portion of the length of suturing material. The leading portion of the length of suturing material and the trailing portion of the length of suturing material are attached together thereby forming a closed length of the suturing material.

[0017] In one version of the method, the leading portion of the length of suturing material is moved to the location near the entry point using a transfer arm located in the interior space of the body. In one version of the method, the leading portion of the length of suturing material and the trailing portion of the length of suturing material are fused together using a pair of heating elements that are moved into contact with the leading portion and the trailing portion of the length of suturing material. The length of suturing material can be provided from a supply of suturing material located in the device.

[0018] In one version of the method, a mesh is placed over the tissue and thereafter the shaft is rotated about its longitudi-

dinal axis thereby penetrating the mesh and the tissue at the entry point. The method can fasten the mesh and the tissue laparoscopically. In one non-limiting example, the method is used in performing laparoscopic sacrocolpopexy or sacrocer-vicopexy.

[0019] In yet another aspect of the invention, there is provided a device for suturing tissue in a patient. The suturing device includes an elongated body having an outer wall defining an interior space of the body, and a needle positioned inside the body for translating in the body. A distal end of the needle terminates in a piercing tip suitable for grasping a suturing material. The piercing tip is movable between a first position in which the piercing tip is positioned in a first section of the interior space of the body and a second position in which the piercing tip is positioned in a second section of the interior space of the body. A length of suturing material is arranged in the second section of the interior space of the body. The piercing tip of the needle follows a first path when moving from the first position to the second position in which the piercing tip exits the first section of the interior space of the body, enters and exits an external space located outside of the body, and enters the second section of the interior space of the body where the piercing tip of the needle grasps a leading portion of the length of suturing material. The piercing tip of the needle follows a second path when moving from the second position to the first position in which the piercing tip exits the second section of the interior space of the body, enters and exits the external space, and is positioned near or in the first section of the interior space of the body. Preferably, the first path and the second path are substantially the same. The first path and/or the second path may be curved. The suturing material can be provided from a supply of suturing material, and a distal segment of suturing material is arranged in the second section of the interior space of the body such that the piercing tip can grasp the suturing material when the needle is in the second position.

[0020] The suturing device further includes an attachment device for securing together a leading portion of the length of suturing material and a trailing portion of the length of suturing material thereby forming a closed length of the suturing material. The leading portion of the length of suturing material and the trailing portion of the length of suturing material are positioned near each other when the piercing tip of the needle is at an end of the second path. The attachment device can include a heating element movable between an initial position and a heat sealing position for placing the leading portion of the length of suturing material and the trailing portion of the length of suturing material in contact and heat sealing the leading portion of the length of suturing material and the trailing portion of the length of suturing material together. The attachment device can be a plunger that terminates in the heating element. The plunger can move transversely with respect to a longitudinal axis of the body when the plunger moves between the initial position and the heat sealing position.

[0021] In one form, the piercing tip of the needle has a slit for receiving the leading portion of the length of suturing material thereby grasping the leading portion of the length of suturing material in the piercing tip of the needle. In one form, the second section of the interior space of the body comprises a hollow extension that extends longitudinally outward beyond the first section of the interior space of the body.

[0022] In still another aspect of the invention, there is provided method for suturing tissue in a patient. The method uses

a suturing device including an elongated body having an outer wall defining an interior space of the body, and a needle positioned inside the body for translating in the body. A distal end of the needle terminates in a piercing tip suitable for grasping a suturing material. The piercing tip is movable between a first position in which the piercing tip is positioned in a first section of the interior space of the body and a second position in which the piercing tip is positioned in a second section of the interior space of the body. The piercing tip is located near the tissue with the piercing tip in the first position. The piercing tip is moved from the first position to the second position such that the piercing tip exits the first section of the interior space of the body, enters and exits tissue positioned in an external space located outside of the body of the device, and enters the second section of the interior space of the body where the piercing tip of the needle grasps a leading portion of the length of suturing material. The length of suturing material can be provided from a supply of suturing material located in the device.

[0023] The piercing tip and the leading portion of the length of suturing material are moved from the second position to the first position in which the piercing tip and the leading portion of the length of suturing material exit the second section of the interior space of the body, enter and exit the tissue positioned in the external space, and are positioned near or in the first section of the interior space of the body. A trailing portion of the length of suturing material is then moved to a location near the leading portion of the length of suturing material. The leading portion of the length of suturing material and the trailing portion of the length of suturing material are then attached thereby forming a closed length of the suturing material.

[0024] The trailing portion of the length of suturing material can be moved to the location near the leading portion of the length of suturing material using a plunger located in the body. The leading portion of the length of suturing material and the trailing portion of the length of suturing material can be fused together using a heating element on the plunger wherein the heating element is moved into contact with at least one of the leading portion and the trailing portion of the length of suturing material. The plunger can move the trailing portion of the length of suturing material laterally with respect to a longitudinal axis of the body.

[0025] A mesh can be placed over the tissue before locating the piercing tip near the tissue. The piercing tip and the leading portion of the length of suturing material can be moved through the mesh. In one version of the method, the mesh and the tissue are fastened laparoscopically. In one non-limiting example, the method is used in performing laparoscopic sacrocolpopexy or sacrocervicopexy.

[0026] These and other features, aspects, and advantages of the present invention will become better understood upon consideration of the following detailed description, drawings, and appended claims.

BRIEF DESCRIPTION OF THE DRAWINGS

[0027] FIG. 1 is a top, right perspective view of a first embodiment of a suturing device according to the invention.

[0028] FIG. 2 is a top, right detailed perspective view of the distal end of the suturing device of FIG. 1.

[0029] FIG. 3 is a side view of the needle of the suturing device of FIG. 1.

[0030] FIG. 4 is a top, right detailed perspective view of the proximal end of the suturing device of FIG. 1.

[0031] FIG. 5 is a side view of needle jaws with a guide wire and associated lever of the suturing device of FIG. 1.

[0032] FIG. 6A is a cross-sectional view of the suturing device of FIG. 1 beginning a suturing method of the invention.

[0033] FIG. 6B is a cross-sectional view of the suturing device of FIG. 1 after the piercing tip of the needle and attached suturing material have entered and exited tissue of the patient.

[0034] FIG. 6C is a cross-sectional view of the suturing device of FIG. 1 during transfer of the suturing material from the piercing tip of the needle to the transfer arm.

[0035] FIG. 6D is a top, right detailed perspective view of the suturing device of FIG. 1 after the transfer arm has moved a leading portion of a length of the suturing material next to a trailing portion of the length of suturing material before fusing the length of the suturing material.

[0036] FIG. 6E is a cross-sectional view of a suture with a fused length of the suturing material prepared using the suturing device of FIG. 1.

[0037] FIG. 7 is a top, right detailed perspective view of a second embodiment of a suturing device according to the invention.

[0038] FIG. 8 is a top, right detailed perspective view of the needle of the suturing device of FIG. 7.

[0039] FIG. 9A is a cross-sectional view of the suturing device of FIG. 7 after the piercing tip of the needle has entered an entry point of the tissue and exited an exit point tissue of the patient.

[0040] FIG. 9B is a cross-sectional view of the suturing device of FIG. 7 after the piercing tip of the needle has pulled attached suturing material back through the entry point of the tissue of the patient.

[0041] FIG. 9C is a cross-sectional view of the suturing device of FIG. 7 after the plunger head has moved a trailing portion of a length of the suturing material next to a leading portion of the length of suturing material.

[0042] FIG. 9D is a cross-sectional view of a suture with a fused length of the suturing material prepared using the suturing device of FIG. 7.

[0043] Like reference numerals will be used to refer to like parts from Figure to Figure in the following description of the drawings.

DETAILED DESCRIPTION OF THE INVENTION

[0044] Referring to FIGS. 1 to 6E, there is shown a first embodiment of a suturing device 10 having an elongated body 12 with an outer wall 13 including first wall section 14 having a generally semi-circular shape in a cross-section transverse to a longitudinal axis A of the body 12, and a second flat wall section 15. The outer wall 13 defines an interior space 16 of the body 12. The interior space 16 generally has a semi cylindrical shape. The body 12 may comprise a polymeric material such as polyethylene or polypropylene. The suturing device 10 includes a handle 18 attached to the body 12. The surgeon can hold on to the suturing device 10 by the handle 18 which may also comprise a polymeric material such as polyethylene or polypropylene. The body 12 of the suturing device 10 can be introduced through an anatomical cavity wall using known laparoscopic surgical techniques. Suitable illumination devices (e.g. optical fibers) can be provided in one or more lumens of the body 12, or can be provided in a separate device that is introduced through the anatomical cavity wall using known laparoscopic surgical

techniques. The suturing device 10 includes a rotatable hollow shaft 20 located centrally in the interior space 16 of the body 12. The shaft 20 has a distal end 21 and a transverse projection 22 fixed to the proximal end of the shaft 20 for rotating the shaft. In the embodiment of the suturing device 10 shown, the projection 22 is disc shaped and includes surface notches for a good grip.

[0045] The suturing device 10 includes a hollow needle 24 having a shank 25 and a distal section 26. The distal section 26 is transverse to the longitudinal axis A of the shaft 20. A first jaw 27 and a second opposed jaw 28 are located at the end of the distal section 26 of the needle 24. The first jaw 27 and the second jaw 28 are movable relative to each other. This can be accomplished by one of the first jaw 27 and the second jaw 28 being movable, or both of the first jaw 27 and the second jaw 28 being movable. Operation of the first jaw 27 and the second jaw 28 will be further described below. The first jaw 27 and the second jaw 28 define a piercing tip 29 of the needle 24.

[0046] The suturing device 10 includes a continuous length of a suturing material 32. The suturing material 32 is provided on a supply reel 33 with an attached feed knob 34 that can be rotated to feed the suturing material 32 from the reel 33. A first feed guide 35 and a second feed guide 36 keep the suturing material 32 suitably tensioned in the interior space 16 of the body 12 when feeding the suturing material 32. The suturing material 32 is preferably thermoplastic to allow for heat sealing of sections of the suturing material 32 together. The suturing material 32 can be, for example, an absorbable material, such as polyglycolic acid, polylactic acid, and polydioxanone, or a non-absorbable material such as nylon and polypropylene (e.g. Prolene®).

[0047] The suturing device 10 includes a hollow transfer arm 40 having a distal end 41 and a push button 42 at its proximal end. A positioner 43 is located near the distal end 41 of the transfer arm 40. A first holding member 44 (see FIG. 6A) and a second holding member 45 (see FIG. 6A) are located at the distal end 41 of the transfer arm 40. The first holding member 44 and the second holding member 45 are movable relative to each other. This can be accomplished by one of the first holding member 44 and the second holding member 45 being movable, or both of the first holding member 44 and the second holding member 45 being movable. Operation of the first holding member 44 and the second holding member 45 will be further described below.

[0048] The suturing device 10 includes a first fusion block 48 and a second fusion block 49. The first fusion block 48 and the second fusion block 49 fuse spaced apart portions of the length of suturing material 32 together as described below. The first fusion block 48 and the second fusion block 49 each include heating element sections that are resistance heated by a suitable source of electricity such as a battery or external AC power supply. Alternatively, just one of the first fusion block 48 and the second fusion block 49 includes a heating element section. The first fusion block 48 and the second fusion block 49 are movable relative to each other. This can be accomplished by one of the first fusion block 48 and the second fusion block 49 being movable, or both of the first fusion block 48 and the second fusion block 49 being movable. In one form, the second fusion block 49 is attached to a guide wire that has a proximal lever on the handle 18. The proximal lever can move the second fusion block 49, which is arranged in a suitable guide support, toward and away from the first fusion block 48.

[0049] Looking now at FIG. 5, operation of the first jaw 27 and the second jaw 28 of the needle 24 can be further described. The first jaw 27 and the second jaw 28 are connected to a first linkage 52 that is attached to a first guide wire 53 having a first lever 54 at its proximal end. The first lever 54 protrudes through the top of the handle 18 (see FIGS. 1 and 4). The first guide wire 53 is contained in the hollow shaft 20 and the hollow needle 24. The first linkage 52 mounts the first jaw 27 and the second jaw 28 at the end of the distal section 26 of the needle 24. Moving the first lever 54 in direction F in FIG. 5 causes the first jaw 27 and the second jaw 28 of the needle 24 to come together, and moving the first lever 54 in direction B in FIG. 5 causes the first jaw 27 and the second jaw 28 of the needle 24 to move apart. Movement of one or both of the first jaw 27 and the second jaw 28 can accomplish this, and the first linkage 52 can be suitably designed to move either one or both of the first jaw 27 and the second jaw 28 when the first lever 54 is moved.

[0050] Likewise, the first holding member 44 and the second holding member 45 are connected to a second linkage that is attached to a second guide wire having a second lever 56 at its proximal end. The second lever 56 protrudes through the top of the handle 18 (see FIGS. 1 and 4). The second guide wire is contained in the hollow transfer arm 40. The second linkage mounts the first holding member 44 and the second holding member 45 at the distal end of the hollow transfer arm 40. Moving the second lever 56 in direction F in FIG. 5 causes the first holding member 44 and the second holding member 45 of the transfer arm 40 to come together, and moving the second lever 56 in direction B in FIG. 5 causes the first holding member 44 and the second holding member 45 of the transfer arm 40 to move apart. Movement of one or both of the first holding member 44 and the second holding member 45 can accomplish this, and the second linkage can be suitably designed to move either one or both of the first holding member 44 and the second holding member 45 when the second lever 56 is moved.

[0051] Looking now at FIGS. 6A to 6E, operation of the suturing device 10 in suturing tissue can be explained. In FIG. 6A, the suturing device 10 is in its initial position, and the second wall section 15 of the body 12 has been placed in contact with a mesh 59 placed on tissue 60. One non-limiting mesh is a polypropylene mesh. The first lever 54 is moved in direction F (as shown in FIG. 5) which causes the first jaw 27 and the second jaw 28 of the needle 24 to come together to grasp a leading portion 61 of the suturing material 32. A trailing portion 63 of the suturing material 32 is located in the body 12.

[0052] The shaft 20 is then rotated in direction R by moving projection 22 in direction R on the handle 18 (see FIG. 1). The piercing tip 29 of the needle 24 passes through a slot 71 (see FIG. 6D) in the second wall section 15 of the body 12 and then penetrates the mesh 59 and an entry point 66 of the tissue 60. By continuing to rotate the shaft 20 in direction R, the piercing tip 29 and the leading portion 61 of the length of suturing material 32 pass through the mesh 59 and the tissue 60 at an exit point 68. The needle 24 and the leading portion 61 of the length of suturing material 32 are then in the position shown in FIG. 6B. Thus, the needle 24 holds the suturing material 32 and pierces the mesh 59 and tissue layer 60 and moves in a rotary path with the suturing material 32 following the rotary path of the needle 24. In FIG. 6B, it can be seen that the transfer arm 40 has located the first holding member 44 and

the second holding member 45 near the leading portion 61 of the length of suturing material 32.

[0053] Referring now to FIG. 6C, the first holding member 44 and the second holding member 45 of the transfer arm 40 are moved next to the leading portion 61 of the length of suturing material 32 by way of button 42 on the handle 18 (see FIG. 1). Movement of the second lever 56 in direction F in FIG. 5 causes the first holding member 44 and the second holding member 45 of the transfer arm 40 to come together and grasp the leading portion 61 of the length of suturing material 32 as shown in FIG. 6C. The button 42 on the handle 18 can then be rotated transverse to the longitudinal axis A of the body 12. This moves the leading portion 61 of the length of suturing material 32 to a location near the entry point 66 of the tissue 60 such that the leading portion 61 of the length of suturing material 32 is near or contacts the trailing portion 62 of the length of suturing material 32. The leading portion 61 and the trailing portion 62 of the length of suturing material 32 intersect between the first fusion block 48 and the second fusion block 49. This is shown in FIG. 6D.

[0054] When the leading portion 61 and the trailing portion 62 of the length of suturing material 32 are in the position shown in FIG. 6D, the heating element sections of the first fusion block 48 and the second fusion block 49 are brought together on the leading portion 61 and the trailing portion 62 of the length of suturing material 32, and the heating elements are resistance heated. This heat seals together the leading portion 61 of the length of suturing material 32 and the trailing portion 62 of the length of suturing material 32 at a fusion point 73 as shown in FIG. 6E, thereby forming a closed length 82 of the suturing material 32. After fusion of suturing material 32, a cutter on the first fusion block 48 and/or the second fusion block 49 cuts the suturing material 32 near the fusion point 73. The needle 24 can then be rotated back to the initial position shown in FIG. 6A by moving projection 22 on the handle 18 in a direction opposite to direction R. The steps described above with reference to FIGS. 6A to 6E can then be repeated to create another closed length 82 of the suturing material 32 at a different location on the mesh 59 and the tissue 60.

[0055] Thus, operation of the suturing device 10 as shown in FIGS. 6A to 6E can be summarized as follows: (1) the suturing device 10 is provided with pre-loaded reel 33 of suturing material 32; (2) the leading portion 61 of the length of suturing material 32 is grasped by the jaws 27, 28 of the rotary needle 24 by moving the first lever 54; (3) the rotary needle 24 pierces the mesh 59 and the tissue 60; (4) the leading portion 61 of the length of suturing material 32 is picked up by the holding members 44, 45 of the transfer arm 40 by moving the second lever 56; (5) the leading portion 61 of the length of suturing material 32 is then taken back near the initial position of the piercing tip 29 of the needle 24; (6) the fusion blocks 48, 49 are then operated; (7) the rotary needle 24 is reverted back to the initial position; and (8) the procedure is repeated for the next suturing.

[0056] Although FIGS. 6A-6E describe attaching together the leading portion 61 and the trailing portion 62 of the length of suturing material 32 using fusion blocks 48, 49 to create a heat sealed fusion point 73, alternative methods such as knotting, metal strips, plastic strips, and glue can be used for attaching together the leading portion 61 and the trailing portion 62 of the length of suturing material 32 to form the closed length 82 of the suturing material 32.

[0057] Referring now to FIGS. 7 to 9D, there is shown a second embodiment of a suturing device 110 having an elongated body 112 including a main outer wall 113 and a transverse wall 114 with an opening 115. The body 112 defines an interior space 116 of the suturing device 110, and the body 112 has a longitudinal axis A. The body 112 can comprise a polymeric material such as polyethylene or polypropylene. The body 112 includes a top extension wall 118, a side extension wall 119, and a bottom extension wall 120 that extend longitudinally outward from the body 112. The bottom extension wall 120 includes an oblong slot 121.

[0058] The suturing device 110 includes a handle (similar to handle 18 in FIG. 1) attached to the body 112. The surgeon can hold on to the suturing device 110 by the handle, which may also comprise a polymeric material such as polyethylene or polypropylene. The body 112 of the suturing device 110 can be introduced through an anatomical cavity wall using known laparoscopic surgical techniques. Suitable illumination devices (e.g. optical fibers) can be provided in one or more lumens of the body 112, or can be provided in a separate device that is introduced through the anatomical cavity wall using known laparoscopic surgical techniques.

[0059] The suturing device 110 includes a needle 124 that slidably translates in a sleeve 125 (see FIG. 8). The needle 124 has a distal section 126 having a longitudinal slit 127. The distal section 126 of the needle 124 defines a piercing tip 129 of the needle 124.

[0060] The suturing device 110 includes a continuous length of a suturing material 132. The suturing material 132 is provided on a supply reel with an attached feed knob that can be rotated to feed the suturing material 132 from the reel (similar to reel 33 and feed knob 34 in FIG. 1). Suitable feed guides keep the suturing material 132 suitably tensioned in the interior space 116 of the body 112 when feeding the suturing material 132. The suturing material 132 is preferably thermoplastic to allow for heat sealing of sections of the suturing material 132 together. The suturing material 132 can be, for example, an absorbable material, such as polyglycolic acid, polylactic acid, and polydioxanone, or a non-absorbable material such as nylon and polypropylene (e.g. Prolene®).

[0061] The suturing device 110 includes a suturing material attachment mechanism. A guide wire 139 includes a plunger 140 that terminates in a heating element 141. The heating element 141 is resistance heated by a suitable source of electricity such as a battery or external AC power supply. A plunger guide 143 transitions the plunger 140 from proximal to distal motion to motion transverse to the longitudinal axis A of the body 112.

[0062] Looking now at FIGS. 7 and 9A to 9D, operation of the suturing device 110 in suturing tissue can be explained. In FIG. 9A, a mesh 159 has been placed on tissue 160. One non-limiting example mesh is a polypropylene mesh. The needle 124 has been advanced in the sleeve 125 and the piercing tip 129 of the needle 124 has penetrated the mesh 159 and an entry point 166 of the tissue 160, and has passed through the tissue 160 at an exit point 168 and the mesh 159, and has passed through the slot 121 into a section of the interior space 116 defined by the top extension wall 118, the side extension wall 119, and the bottom extension wall 120 that extend longitudinally outward from the body 112. The slit 127 of the needle 124 has grasped a leading portion 161 of the length of suturing material 132. This position is shown in FIGS. 7 and 9A.

[0063] Referring now to FIG. 9B, the needle 124 has been retracted in the sleeve 125 and the piercing tip 129 and the leading portion 161 of the length of suturing material 132 have passed through the mesh 159 and the tissue 160 at the exit point 168, and have passed through the tissue 160, and have passed through the tissue 160 at the entry point 166 and the mesh 159. The needle 124 and the leading portion 161 of the length of suturing material 132 are then in the position shown in FIG. 9B in which the leading portion 161 of the length of suturing material 132 is positioned near or in a section of the interior space 116 of the body 112.

[0064] When the leading portion 161 of the length of suturing material 132 is in the position in FIG. 6B, the plunger 140 with heating element 141 exits the plunger guide 143 and moves transverse to the longitudinal axis A of the body 112. See direction T in FIG. 9B. The end surface of the plunger 140 contacts a trailing portion 162 of the length of suturing material 132 and moves the trailing portion 162 of the length of suturing material 132 into contact with the leading portion 161 of the length of suturing material 132 as shown in FIG. 9C. The heating element 141 is resistance heated, and this fuses together the leading portion 161 of the length of suturing material 132 and the trailing portion 162 of the length of suturing material 132 at a fusion point 173 as shown in FIG. 9D, thereby forming a closed length 182 of the suturing material 132. After fusion of suturing material 132, a cutter on the plunger 140 cuts the suturing material 132 near the fusion point 173. The steps described above with reference to FIGS. 9A to 9D can then be repeated to create another closed length 182 of the suturing material 132 at a different location on the mesh 159 and the tissue 160.

[0065] Looking at FIGS. 9A and 9B, the needle 124 follows a generally curved path between the entry point 166 of the tissue 160 and the exit point 168 of the tissue 160. The distal section 126 of the needle 124 can be formed of a highly elastic material (e.g., a superelastic nickel-titanium alloy) to facilitate the curved path through the tissue 160. Specifically, the distal section 126 of the needle 124 can have a curved shape similar to the curved path desired through the tissue 160. When located in the sleeve 125, the curved shape of the distal section 126 of the needle 124 can assume the straight configuration of the inner space of the sleeve 125. When the distal section 126 of the needle 124 is moved out of the distal end of the sleeve 125 and through the opening 115 in the transverse wall 114 of the body 112, the distal section 126 of the needle 124 elastically returns to a curved shape similar to the curved path desired through the tissue 160. Preferably, the needle 124 follows substantially the same generally curved path when moving in either direction between the entry point 166 of the tissue 160 and the exit point 168 of the tissue 160. However, as long as the length of suturing material 132 is guided through the tissue 160, the path of the needle can vary when moving in opposite directions between the entry point 166 of the tissue 160 and the exit point 168 of the tissue 160.

[0066] Thus, the invention provides suturing devices and associated methods that can automate the process of fastening tissue and mesh laparoscopically. While the suturing devices are especially advantageous for performing laparoscopic sacrocolpopexy or sacrocervicopexy, the suturing devices can be used in any procedure where tissue is sutured.

[0067] Although the present invention has been described in detail with reference to certain embodiments, one skilled in the art will appreciate that the present invention can be practiced by other than the described embodiments, which have

been presented for purposes of illustration and not of limitation. Therefore, the scope of the invention should not be limited to the description of the embodiments contained herein.

1. A suturing device comprising:

an elongated body having an outer wall defining an interior space of the body;

a rotatable shaft located in the interior space of the body; and

a needle mounted on a distal end of the shaft, the needle having a distal section transverse to a longitudinal axis of the shaft, the distal section of the needle terminating in a first jaw and a second opposed jaw, at least one of the first jaw and the second jaw being movable relative to the other of the first jaw and the second jaw such that the first jaw and the second jaw have a grasping position in which the first jaw and the second jaw can grasp a suturing material and the first jaw and the second jaw have a release position in which the first jaw and the second jaw release the suturing material, the first jaw and the second jaw defining a piercing tip when the first jaw and the second jaw are in the grasping position.

2. (canceled)

3. The suturing device of claim 1 wherein:

the suturing device further comprises a handle mounted to the elongated body, and

the shaft is fixed to a transverse projection for rotating the shaft, and

the projection is located on the handle.

4. The suturing device of claim 1 wherein:

the needle has a first position in which the piercing tip faces away from the interior space of the body, and

the needle has a second position in which the piercing tip faces toward the interior space of the body, and

the needle follows a curved path from the first position to the second position when the shaft is rotated about its longitudinal axis.

5. The suturing device of claim 4 wherein:

the first jaw and the second jaw are in the grasping position thereby grasping the suturing material when the needle moves from the first position to the second position when the shaft is rotated about its longitudinal axis.

6. The suturing device of claim 4 wherein:

the suturing material is provided from a supply of suturing material, and

a distal segment of suturing material is arranged in the interior space of the body such that the first jaw and the second jaw can grasp the suturing material when the needle is in the first position.

7. The suturing device of claim 4 wherein:

the outer wall of the body includes a slot, and

the needle passes through the slot when the needle moves from the first position to the second position when the shaft is rotated about its longitudinal axis.

8. The suturing device of claim 4 wherein:

the suturing device further comprises a transfer arm located in the interior space of the body, the transfer arm terminating in a first holding member and a second opposed holding member, at least one of the first holding member and the second holding member being movable relative to the other of the first holding member and the second holding member such that the first holding member and the second holding member have a holding position in which the first holding member and the second holding

member hold the suturing material and the first holding member and the second holding member have a disengaged position in which the first jaw and the second jaw disengage the suturing material.

9. The suturing device of claim **8** wherein:

the suturing device further comprises an attachment device for securing together spaced apart portions of the suturing material thereby forming a closed length of the suturing material.

10. The suturing device of claim **9** wherein:

the attachment device comprises a pair of heating elements movable between an open position in which the heating elements are spaced apart and a heat sealing position for contacting the spaced apart portions of the suturing material and heat sealing the spaced apart portions of the suturing material together.

11. The suturing device of claim **10** wherein:

the suturing material is transferred from the first jaw and the second jaw of the needle to the first holding member and the second holding member of the transfer arm when the needle is in the second position, and

the transfer arm orients the spaced apart portions of the suturing material between the heating elements when the heating elements are in the open position, and

the heating elements are moved into the heat sealing position for contacting the spaced apart portions of the suturing material and heat sealing the spaced apart portions of the suturing material together.

12. (canceled)

13. (canceled)

14. A method for suturing tissue in a patient, the method comprising:

(a) providing a suturing device including (i) an elongated body having an outer wall defining an interior space of the body, (ii) a rotatable shaft located in the interior space of the body, and (iii) a needle mounted on a distal end of the shaft, the needle having a distal section transverse to a longitudinal axis of the shaft, the distal section of the needle terminating in a first jaw and a second opposed jaw, at least one of the first jaw and the second jaw being movable relative to the other of the first jaw and the second jaw;

(b) grasping a leading portion of a length of suturing material with the first jaw and the second jaw of the needle such that the first jaw and the second jaw define a piercing tip;

(c) locating the piercing tip near the tissue;

(d) rotating the shaft about its longitudinal axis thereby penetrating the tissue at an entry point;

(e) continuing to rotate the shaft until the leading portion of the length of suturing material has passed through the tissue and out of an exit point;

(f) moving the leading portion of the length of suturing material to a location near the entry point such that the leading portion of the length of suturing material is near or contacts a trailing portion of the length of suturing material; and

(g) attaching together the leading portion of the length of suturing material and the trailing portion of the length of suturing material thereby forming a closed length of the suturing material.

15. (canceled)

16. (canceled)

17. (canceled)

18. The method of claim **14** wherein:

step (f) comprises moving the leading portion of the length of suturing material to the location near the entry point using a transfer arm located in the interior space of the body.

19. (canceled)

20. (canceled)

21. (canceled)

22. A suturing device comprising:

an elongated body having an outer wall defining an interior space of the body;

a needle positioned inside the body for translating in the body, a distal end of the needle terminating in a piercing tip suitable for grasping a suturing material, the piercing tip being movable between a first position in which the piercing tip is positioned in a first section of the interior space of the body and a second position in which the piercing tip is positioned in a second section of the interior space of the body; and

a length of suturing material arranged in the second section of the interior space of the body,

wherein the piercing tip of the needle follows a first path when moving from the first position to the second position in which the piercing tip exits the first section of the interior space of the body, enters and exits an external space located outside of the body, and enters the second section of the interior space of the body where the piercing tip of the needle grasps a leading portion of the length of suturing material, and

wherein the piercing tip of the needle follows a second path when moving from the second position to the first position in which the piercing tip exits the second section of the interior space of the body, enters and exits the external space, and is positioned near or in the first section of the interior space of the body.

23. The suturing device of claim **22** wherein:

the first path and the second path are substantially the same.

24. The suturing device of claim **22** wherein:

the first path is curved.

25. The suturing device of claim **22** wherein:

the suturing device further comprises an attachment device for securing together a leading portion of the length of suturing material and a trailing portion of the length of suturing material thereby forming a closed length of the suturing material.

26. The suturing device of claim **25** wherein:

the leading portion of the length of suturing material and the trailing portion of the length of suturing material are positioned near each other when the piercing tip of the needle is at an end of the second path, and

the attachment device comprises a heating element movable between an initial position and a heat sealing position for placing the leading portion of the length of suturing material and the trailing portion of the length of suturing material in contact and heat sealing the leading portion of the length of suturing material and the trailing portion of the length of suturing material together.

27. (canceled)

28. (canceled)

29. (canceled)

30. (canceled)

31. The suturing device of claim **22** wherein:

the suturing material is provided from a supply of suturing material, and

a distal segment of suturing material is arranged in the second section of the interior space of the body such that the piercing tip can grasp the suturing material when the needle is in the second position.

32. A method for suturing tissue in a patient, the method comprising:

- (a) providing a suturing device including (i) an elongated body having an outer wall defining an interior space of the body, and (ii) a needle positioned inside the body for translating in the body, a distal end of the needle terminating in a piercing tip suitable for grasping a suturing material, the piercing tip being movable between a first position in which the piercing tip is positioned in a first section of the interior space of the body and a second position in which the piercing tip is positioned in a second section of the interior space of the body;
- (b) locating the piercing tip near the tissue with the piercing tip in the first position;
- (c) moving the piercing tip from the first position to the second position such that the piercing tip exits the first section of the interior space of the body, enters and exits tissue positioned in an external space located outside of the body of the device, and enters the second section of the interior space of the body where the piercing tip of the needle grasps a leading portion of the length of suturing material;

- (d) moving the piercing tip and the leading portion of the length of suturing material from the second position to the first position in which the piercing tip and the leading portion of the length of suturing material exit the second section of the interior space of the body, enter and exit the tissue positioned in the external space, and are positioned near or in the first section of the interior space of the body;

- (e) moving a trailing portion of the length of suturing material to a location near the leading portion of the length of suturing material; and

- (f) attaching together the leading portion of the length of suturing material and the trailing portion of the length of suturing material thereby forming a closed length of the suturing material.

33. The method of claim **32** wherein:

step (e) comprises moving the trailing portion of the length of suturing material to the location near the leading portion of the length of suturing material using a plunger located in the body.

34. (canceled)

35. (canceled)

36. (canceled)

37. (canceled)

38. (canceled)

39. (canceled)

* * * * *

专利名称(译)	用于腹腔镜手术的缝合装置		
公开(公告)号	US20150133968A1	公开(公告)日	2015-05-14
申请号	US14/397682	申请日	2013-04-30
[标]申请(专利权)人(译)	Einarsson的JON		
申请(专利权)人(译)	Einarsson的, JON		
当前申请(专利权)人(译)	布莱根妇女医院, INC.		
[标]发明人	EINARSSON JON		
发明人	EINARSSON, JON		
IPC分类号	A61B17/04 A61B17/062		
CPC分类号	A61B17/0469 A61B17/0491 A61B17/0625 A61B2017/0619 A61B2017/00805 A61B2017/06042 A61B17/0482		
优先权	61/641069 2012-05-01 US		
外部链接	Espacenet USPTO		

摘要(译)

缝合装置包括细长主体，该细长主体具有限定主体的内部空间的外壁，位于内部空间中的轴，以及安装在轴的远端上的针。针具有横向于轴的纵向轴线的远侧部分。针的远端部分终止于第一钳口和第二钳口，形成限定刺穿尖端的钳子。第一钳夹和第二钳夹具有抓握位置，其中第一钳夹和第二钳夹抓住缝合材料，以及释放位置，其中第一钳夹和第二钳夹释放缝合材料。在用针抓住缝合材料之后，轴旋转针以使针前进并缝合材料穿过组织和放置在组织上的网。然后将缝合材料的间隔开的部分熔合以形成缝合线。

