



(19) **United States**
(12) **Patent Application Publication**
Meade et al.

(10) **Pub. No.: US 2008/0255590 A1**
(43) **Pub. Date: Oct. 16, 2008**

(54) **APPARATUS AND METHOD FOR MINIMALLY INVASIVE SUTURING**

(60) Provisional application No. 60/611,362, filed on Sep. 20, 2004.

(76) Inventors: **John C. Meade**, Mendon, MA (US); **Jerry R. Griffiths**, Pembroke, MA (US); **Francis J. DiFrancesco**, Foxboro, MA (US)

Publication Classification

(51) **Int. Cl.**
A61B 17/062 (2006.01)
(52) **U.S. Cl.** **606/144**

Correspondence Address:
EDWARDS ANGELL PALMER & DODGE LLP
P.O. BOX 55874
BOSTON, MA 02205 (US)

(57) **ABSTRACT**

An apparatus and method for minimally invasive suturing is disclosed. A suturing device for minimally invasive suturing includes an elongated barrel having a proximal end, a distal end, and a longitudinal axis therebetween; a suture head assembly extending from the distal end of the elongated barrel; a suturing needle having a pointed end and a blunt end, the suturing needle capable of rotating about an axis approximately perpendicular to a longitudinal axis of the elongated barrel, wherein the pointed end of the suturing needle is positioned within the suture head assembly prior to and after rotation of the suturing needle; and an actuator extending from the proximal end of the elongated barrel to actuate a drive mechanism having a needle driver for engaging and rotating the suturing needle.

(21) Appl. No.: **11/982,174**
(22) Filed: **Nov. 1, 2007**

Related U.S. Application Data

(63) Continuation of application No. 11/231,135, filed on Sep. 20, 2005, Continuation-in-part of application No. 11/387,127, filed on Mar. 22, 2006, which is a continuation-in-part of application No. 10/127,254, filed on Apr. 22, 2002, now Pat. No. 6,923,819.

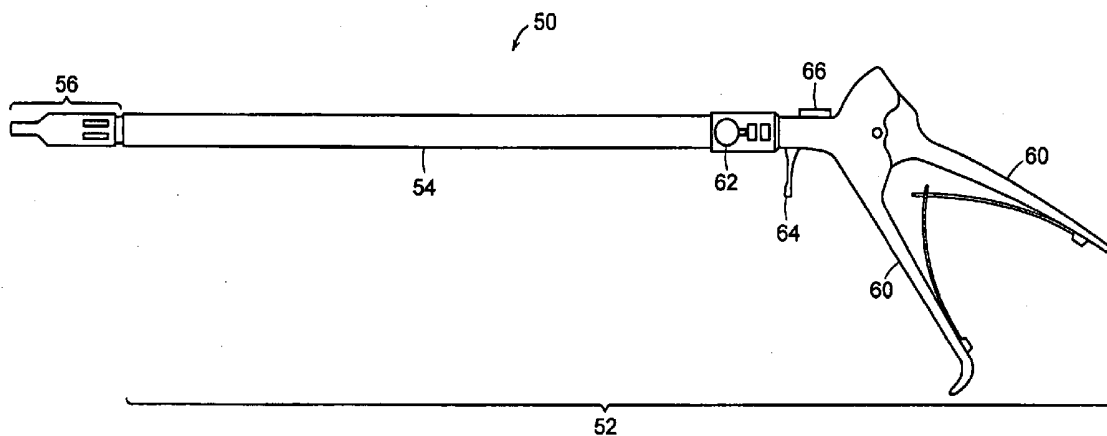

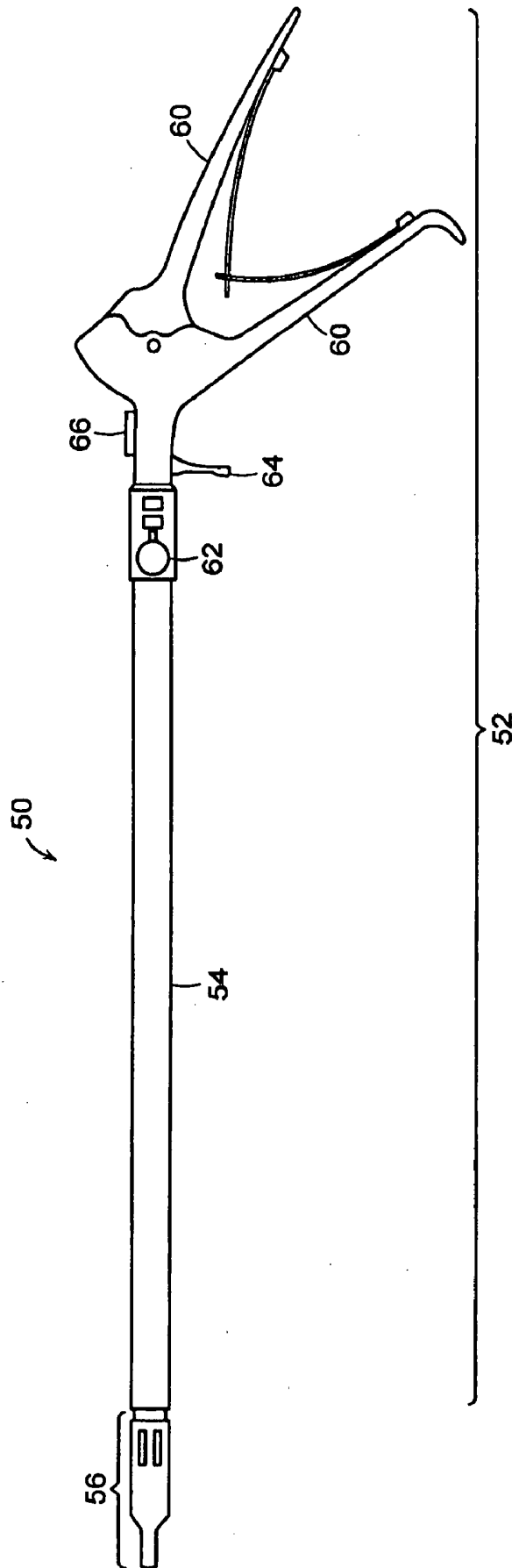

FIG. 1

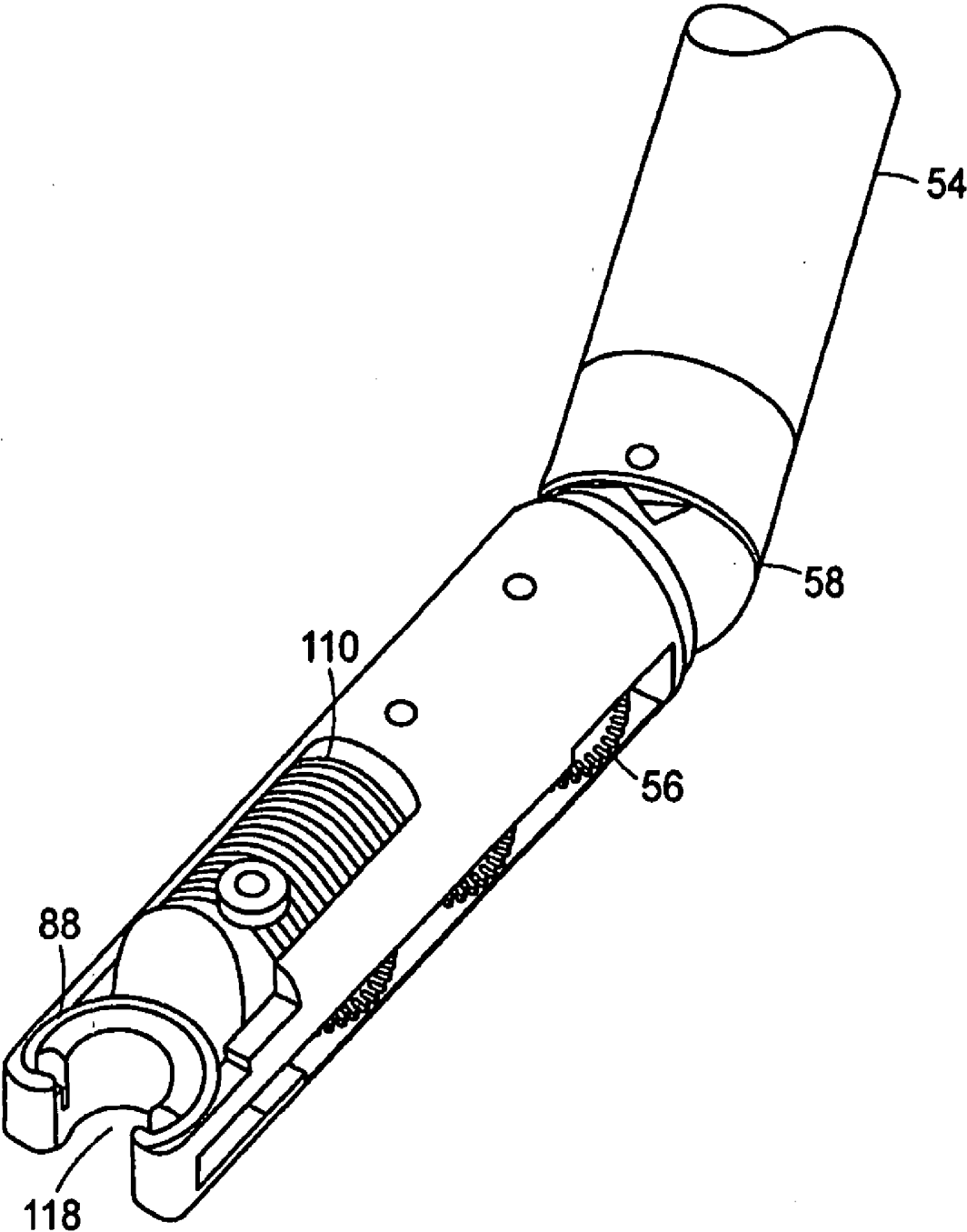
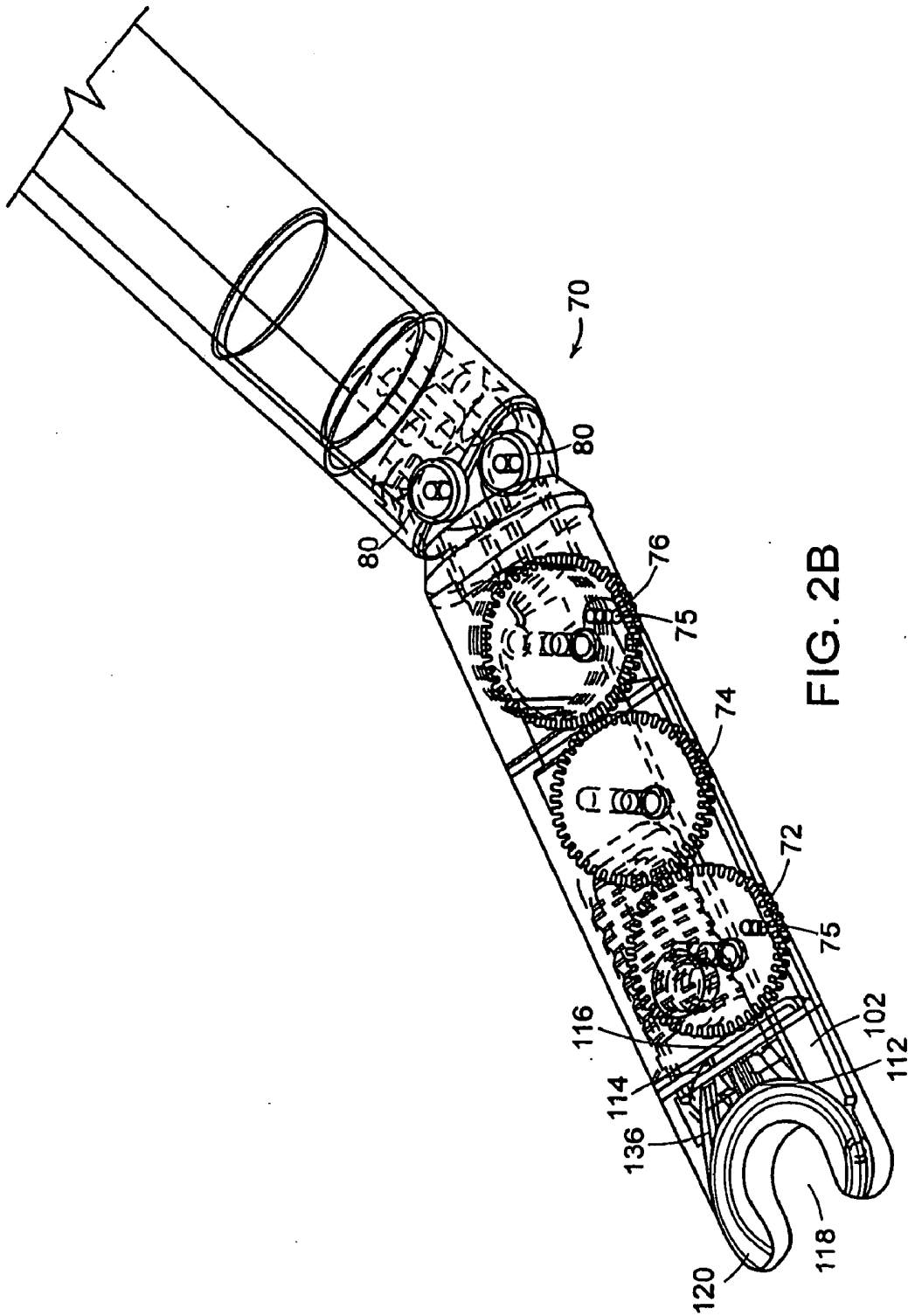

FIG. 2A



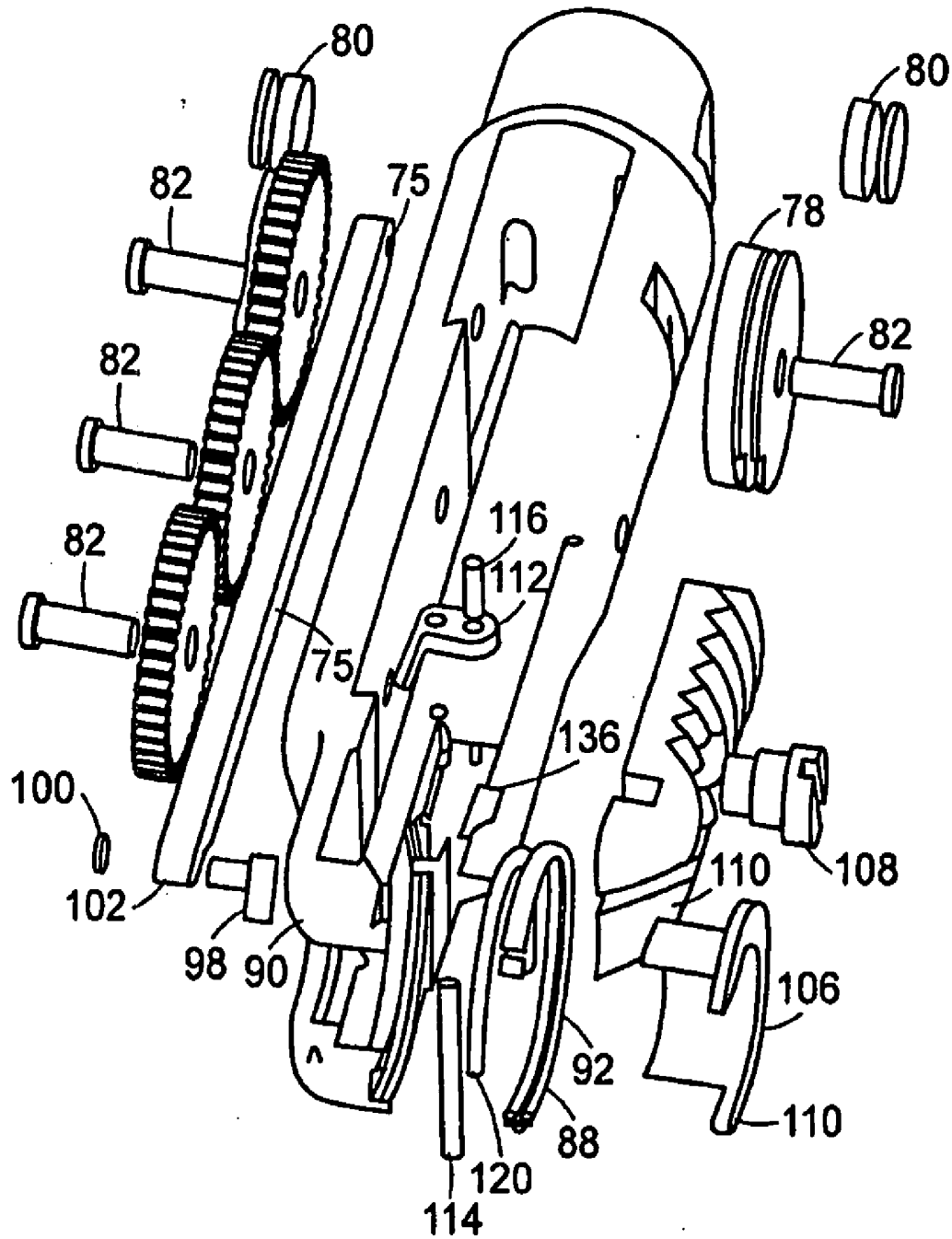

FIG. 3A

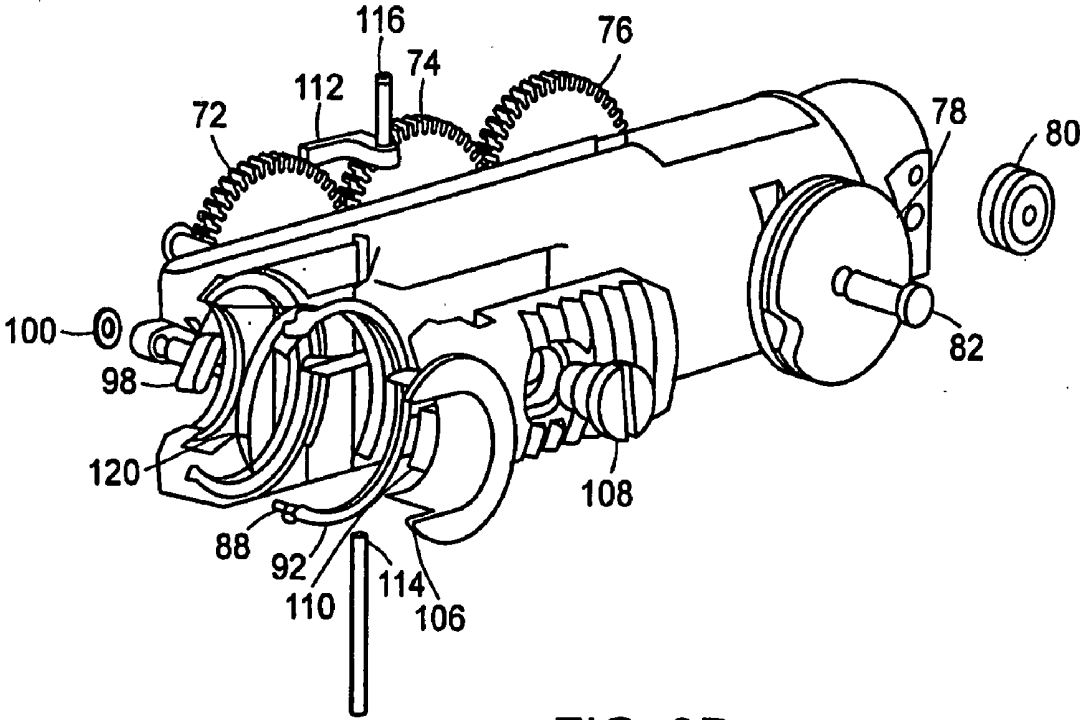

FIG. 3B

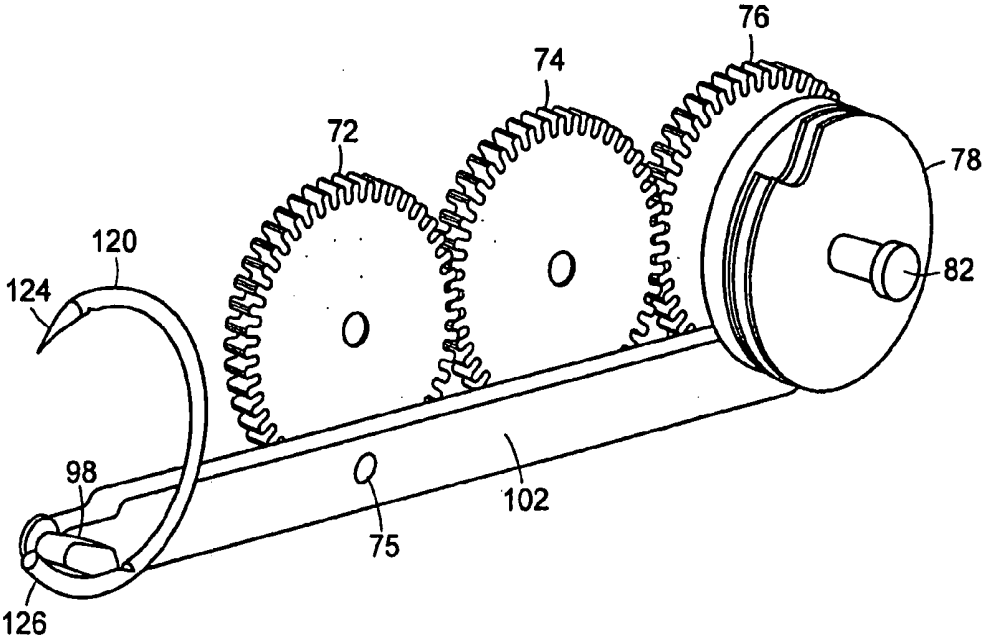

FIG. 4A

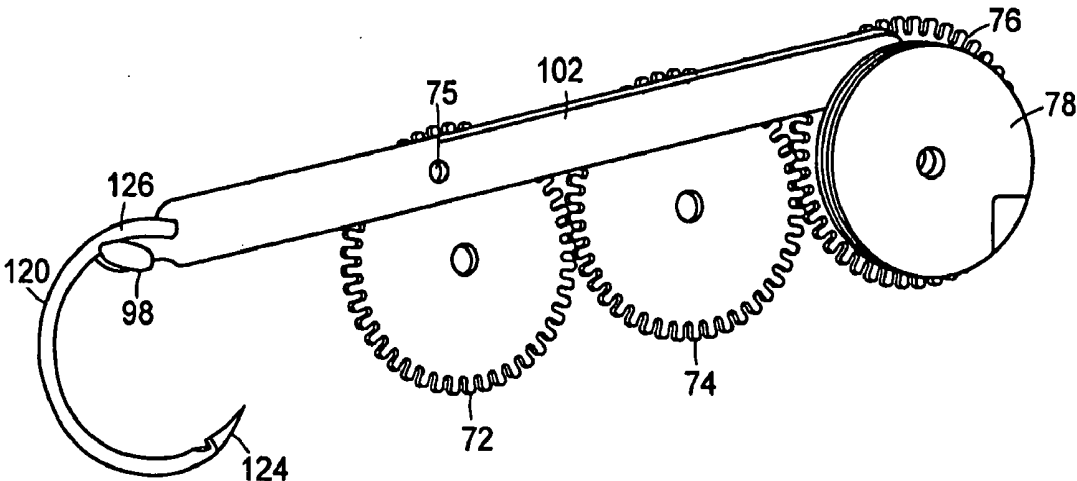

FIG. 4B

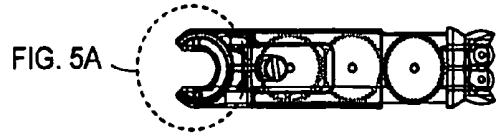

FIG. 5

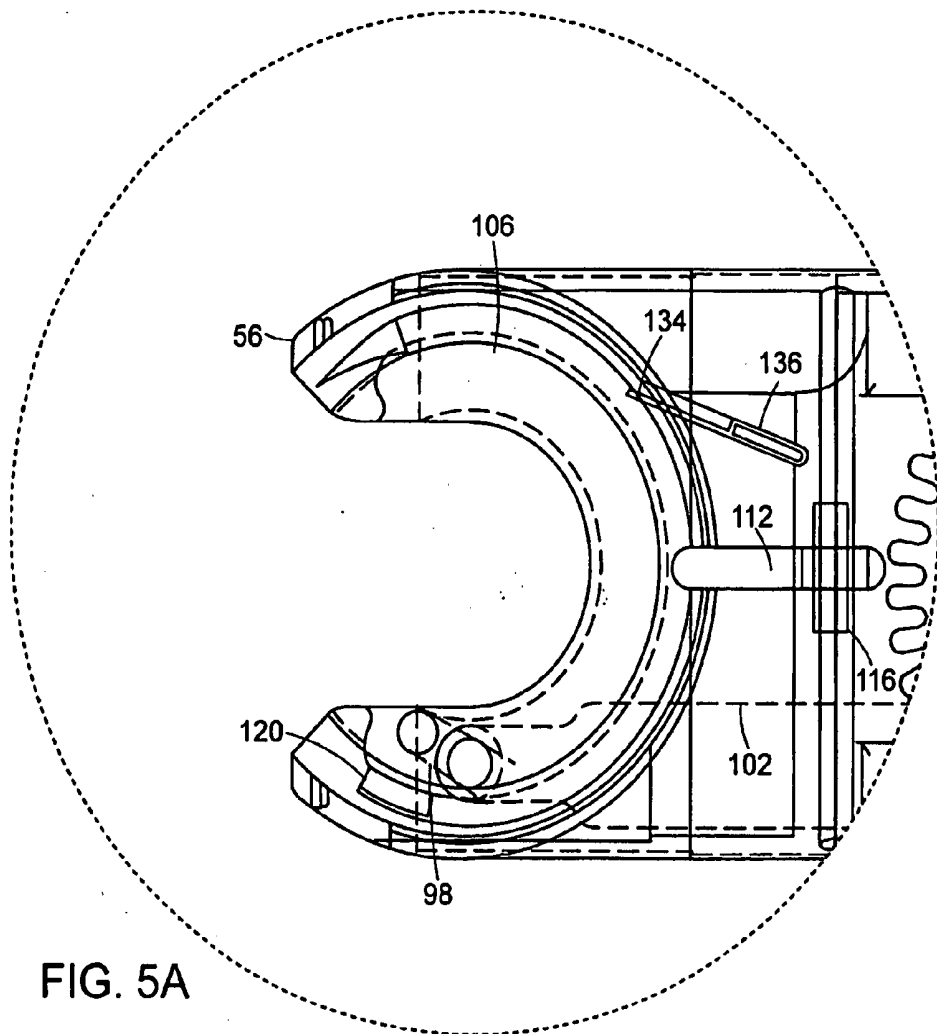

FIG. 5A

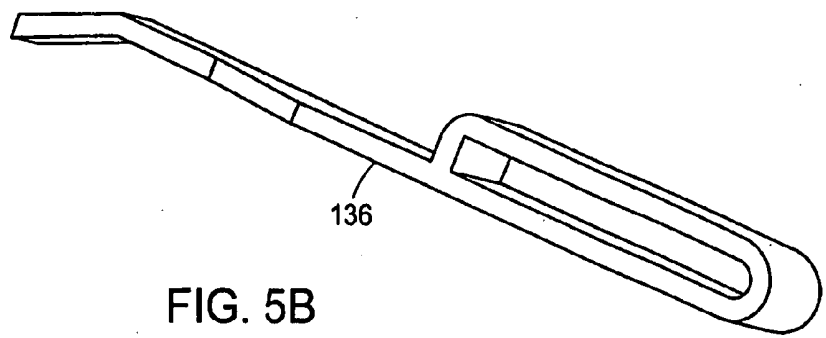

FIG. 5B

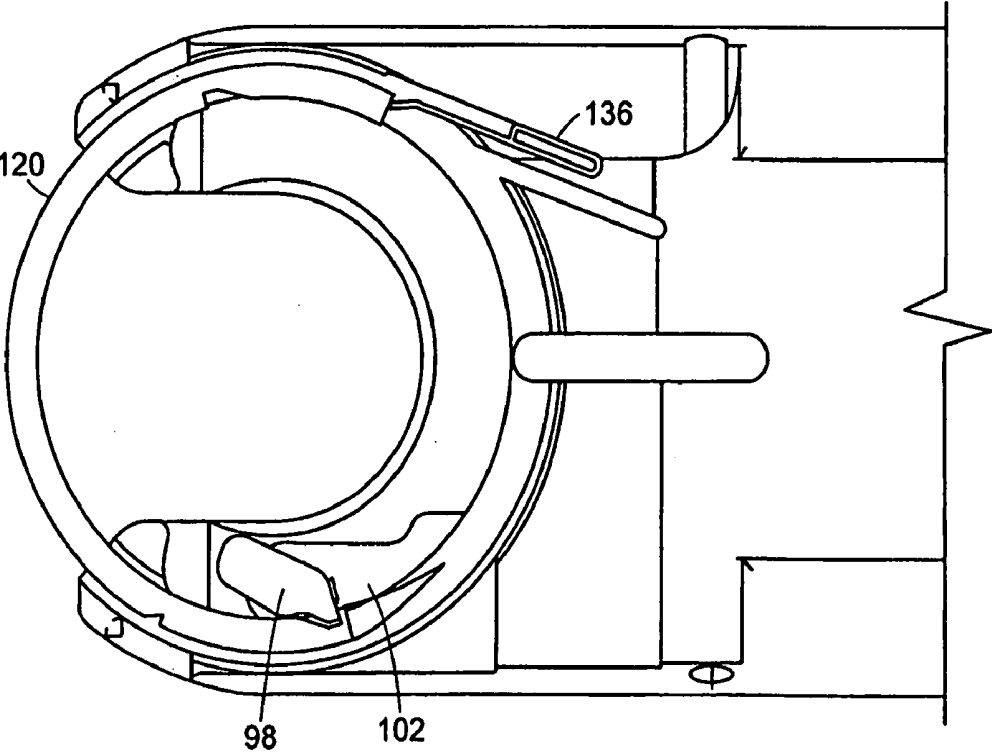
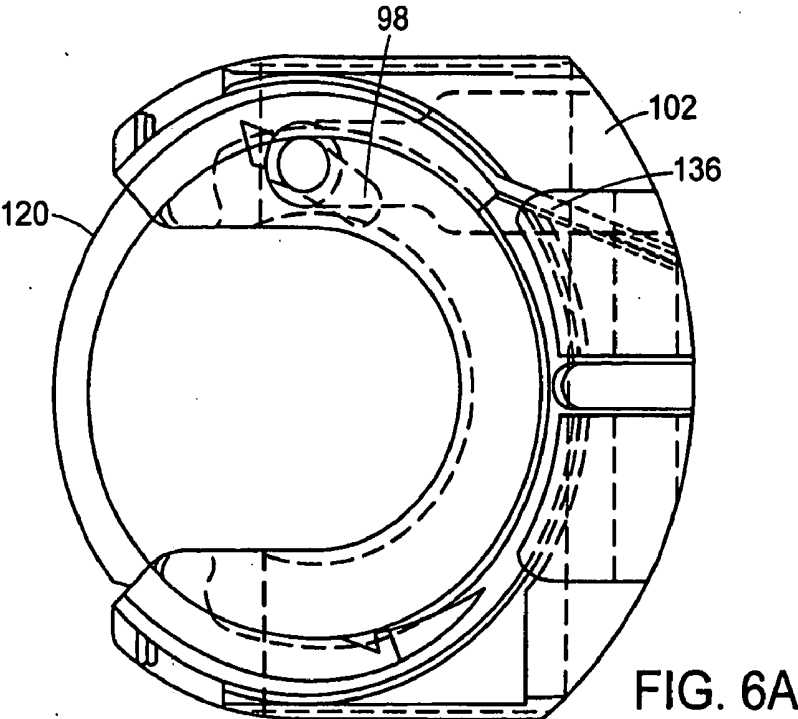

FIG. 6B



FIG. 7

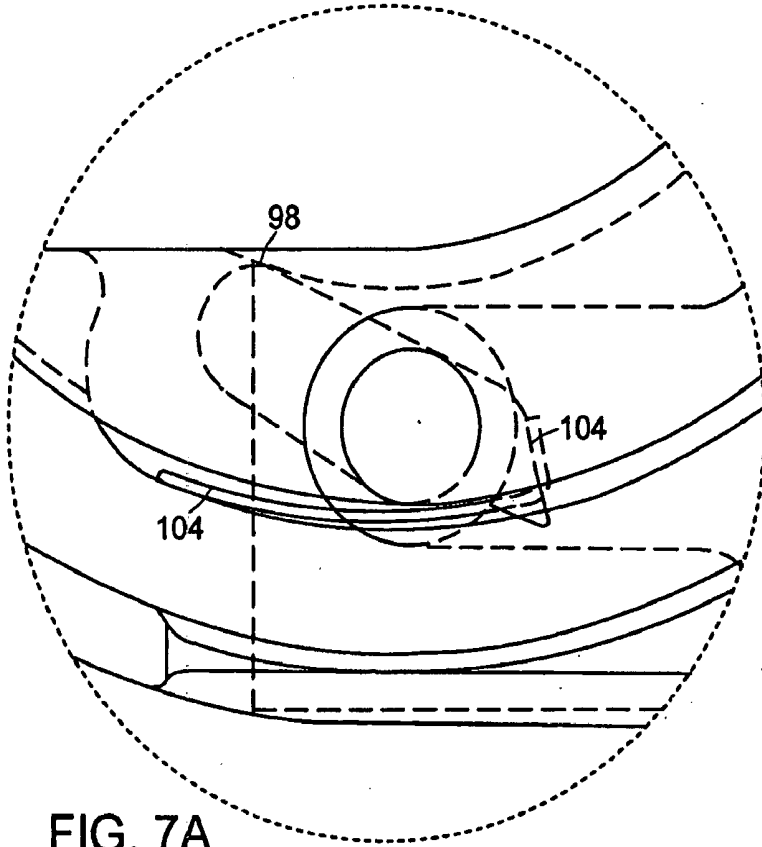

FIG. 7A

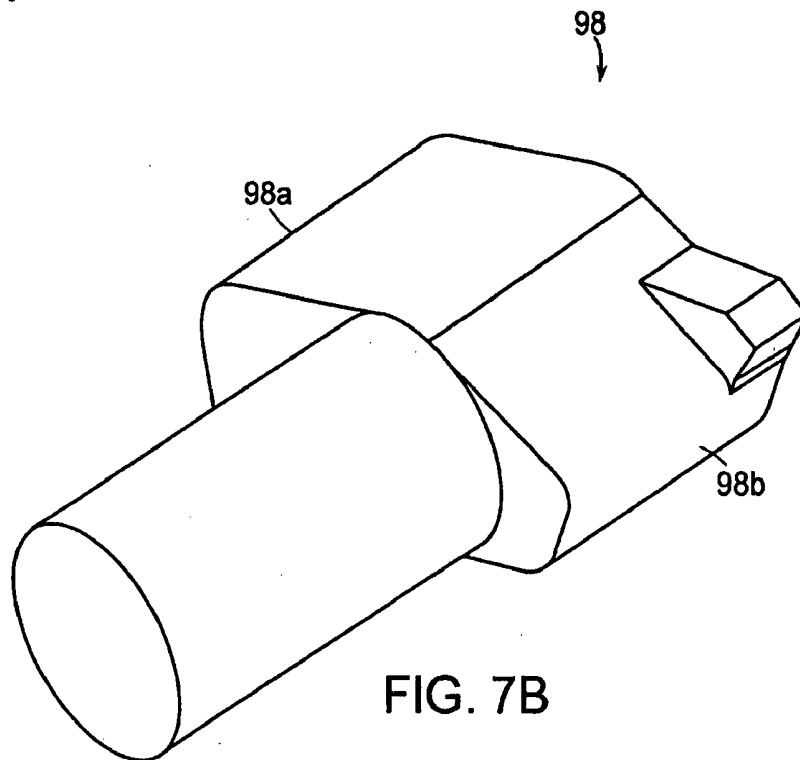

FIG. 7B

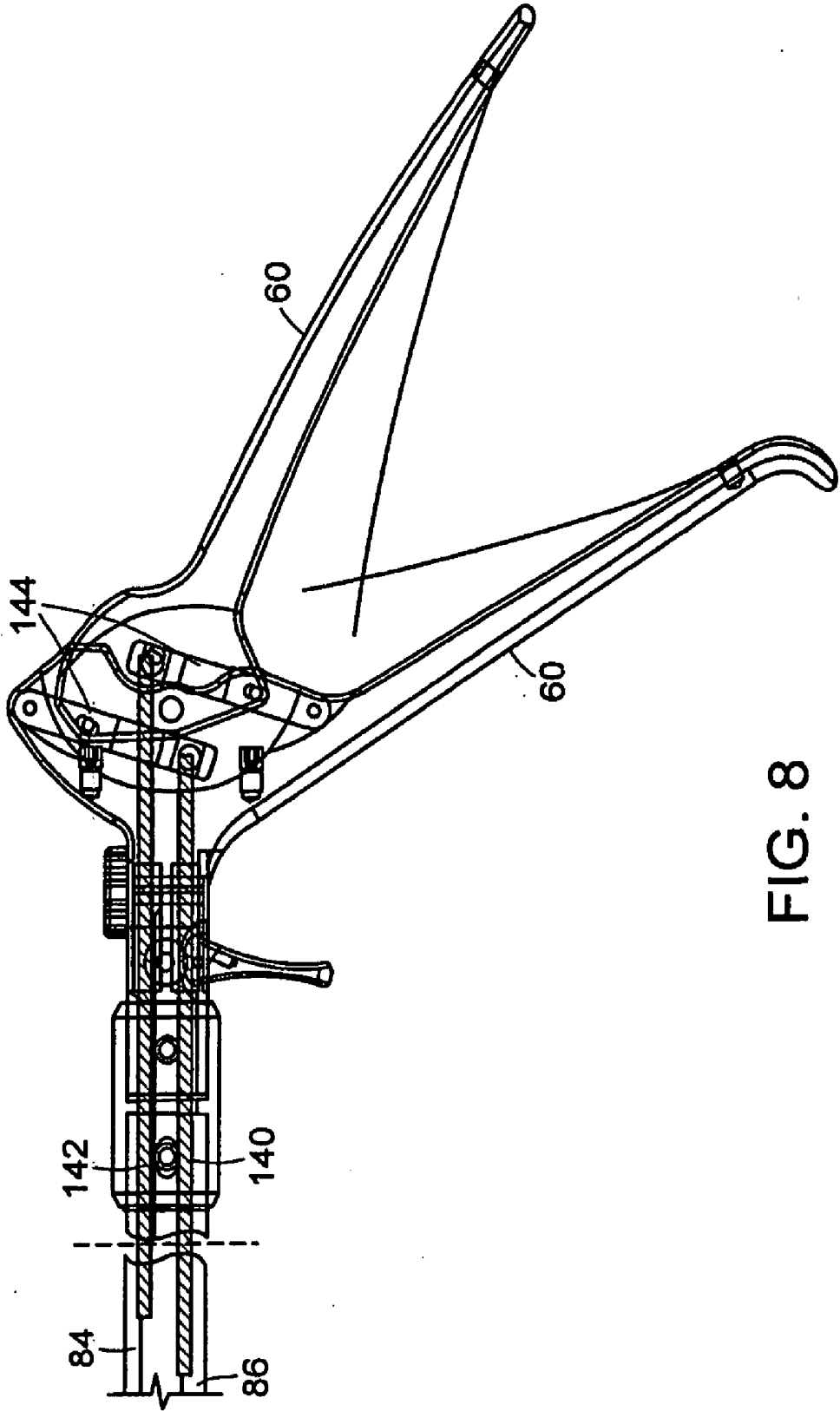

FIG. 8

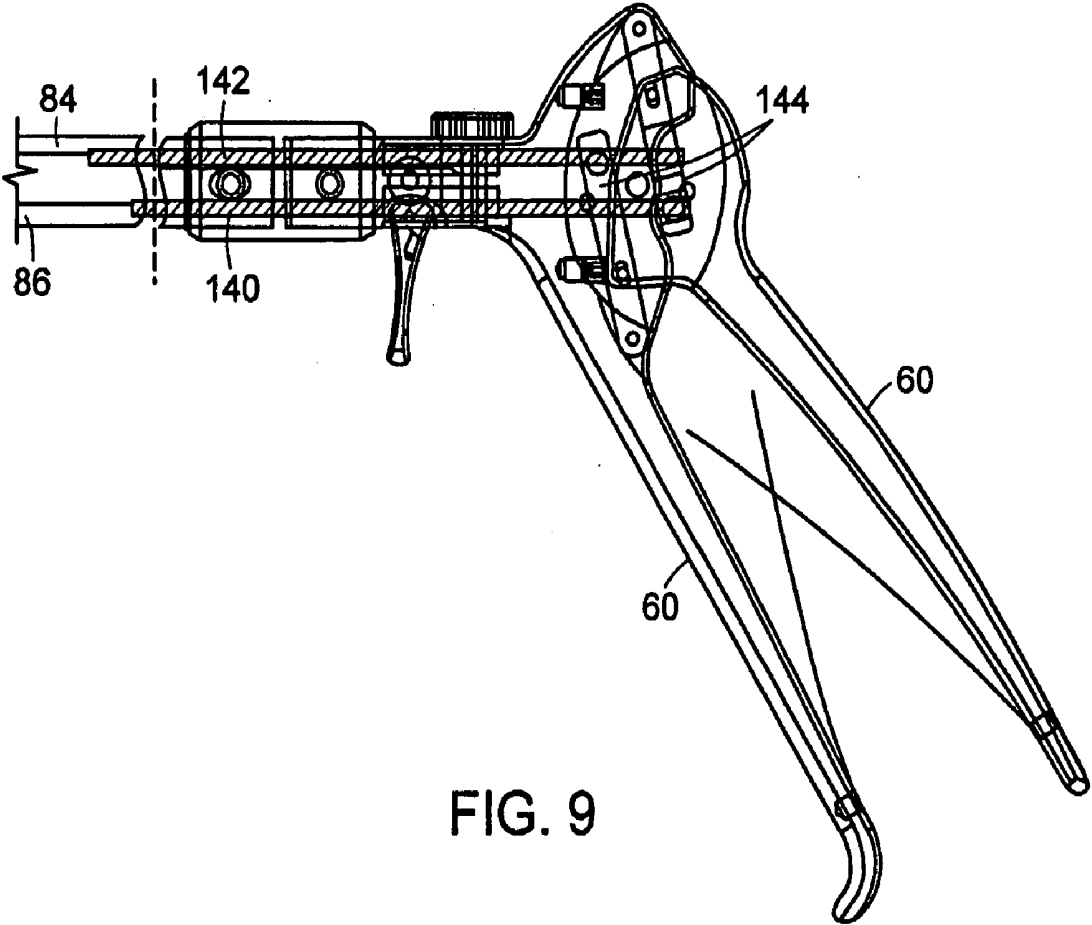

FIG. 9

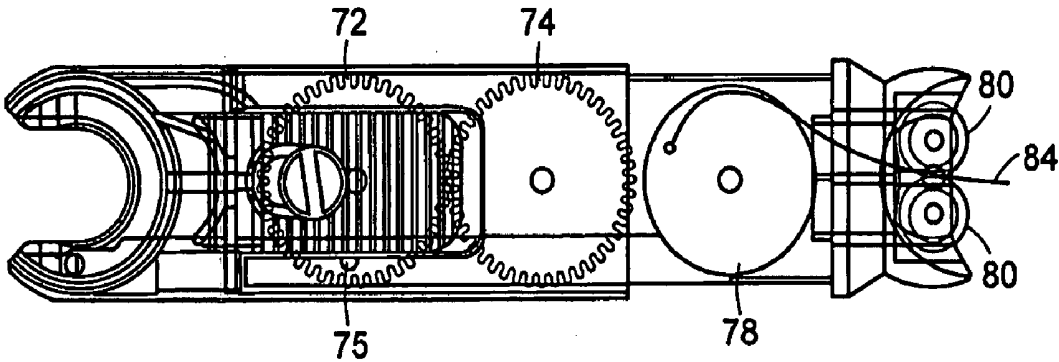

FIG. 10

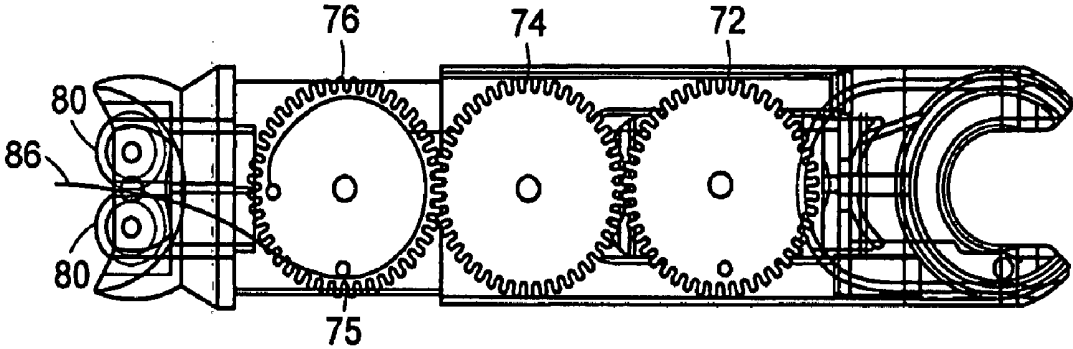

FIG. 11

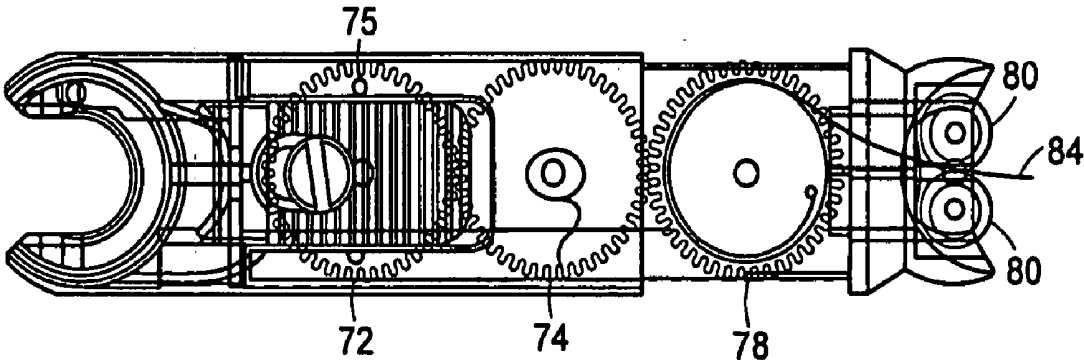

FIG. 12

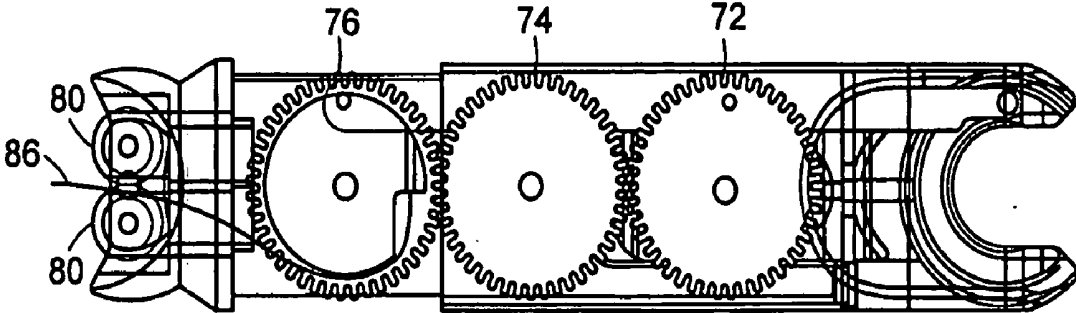

FIG. 13

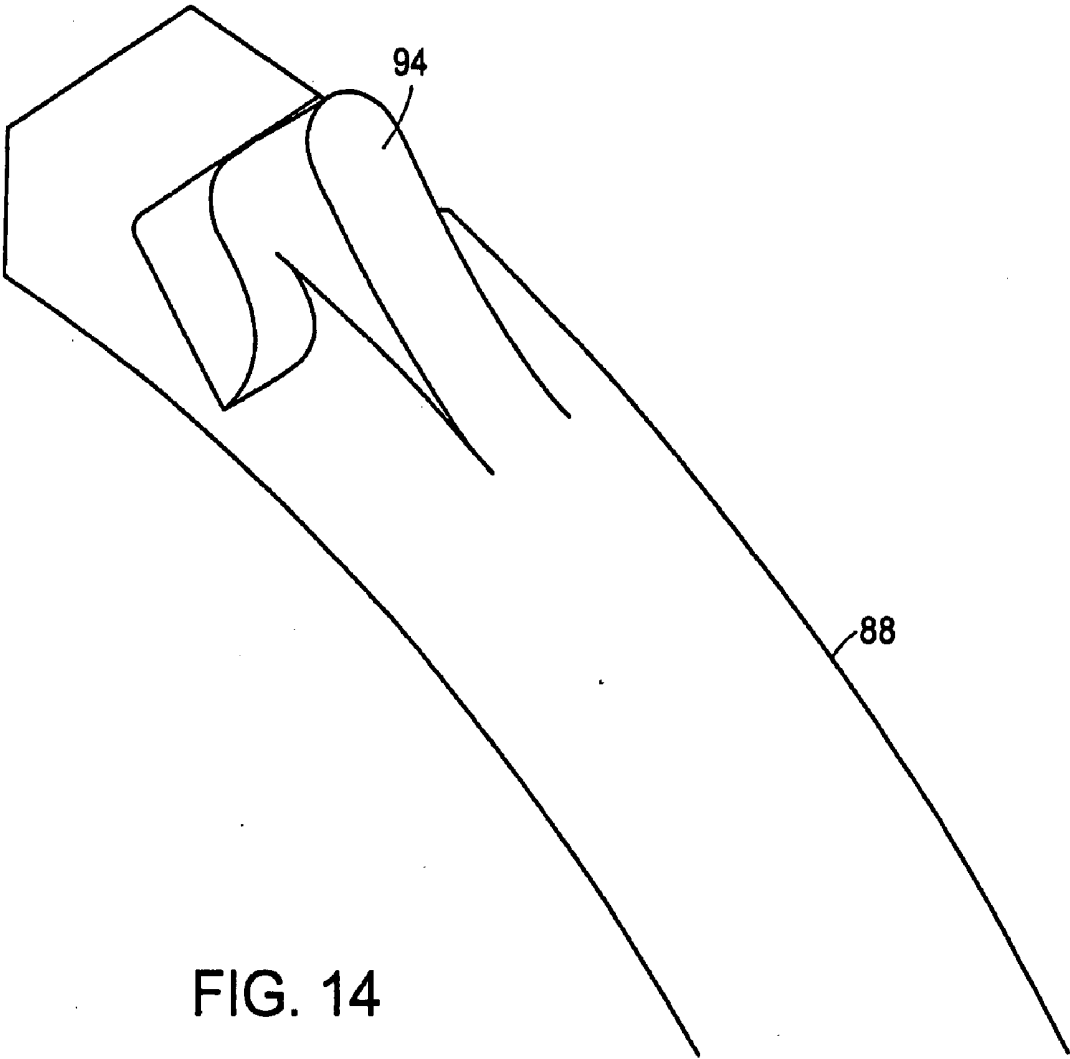

FIG. 14

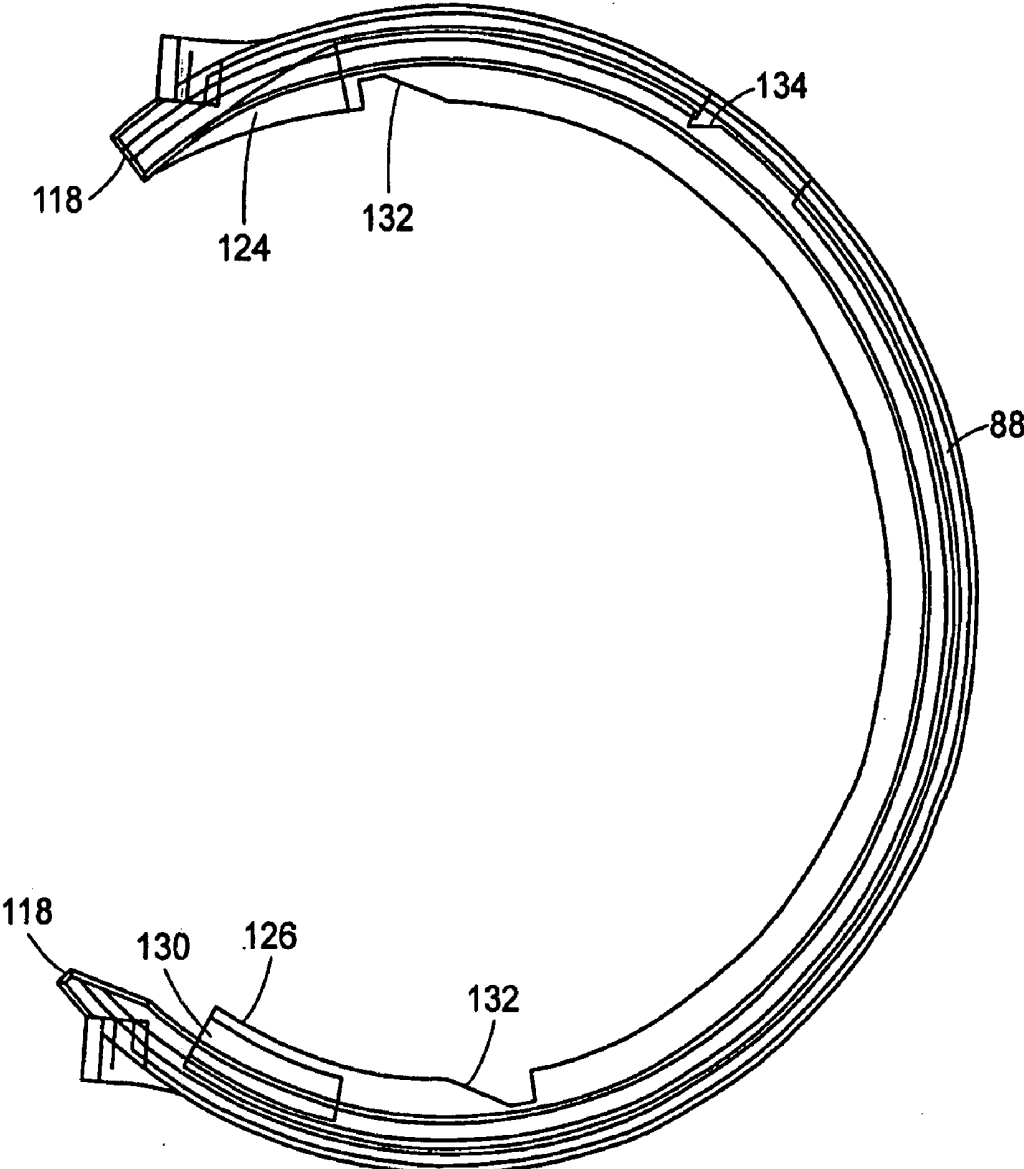

FIG. 15

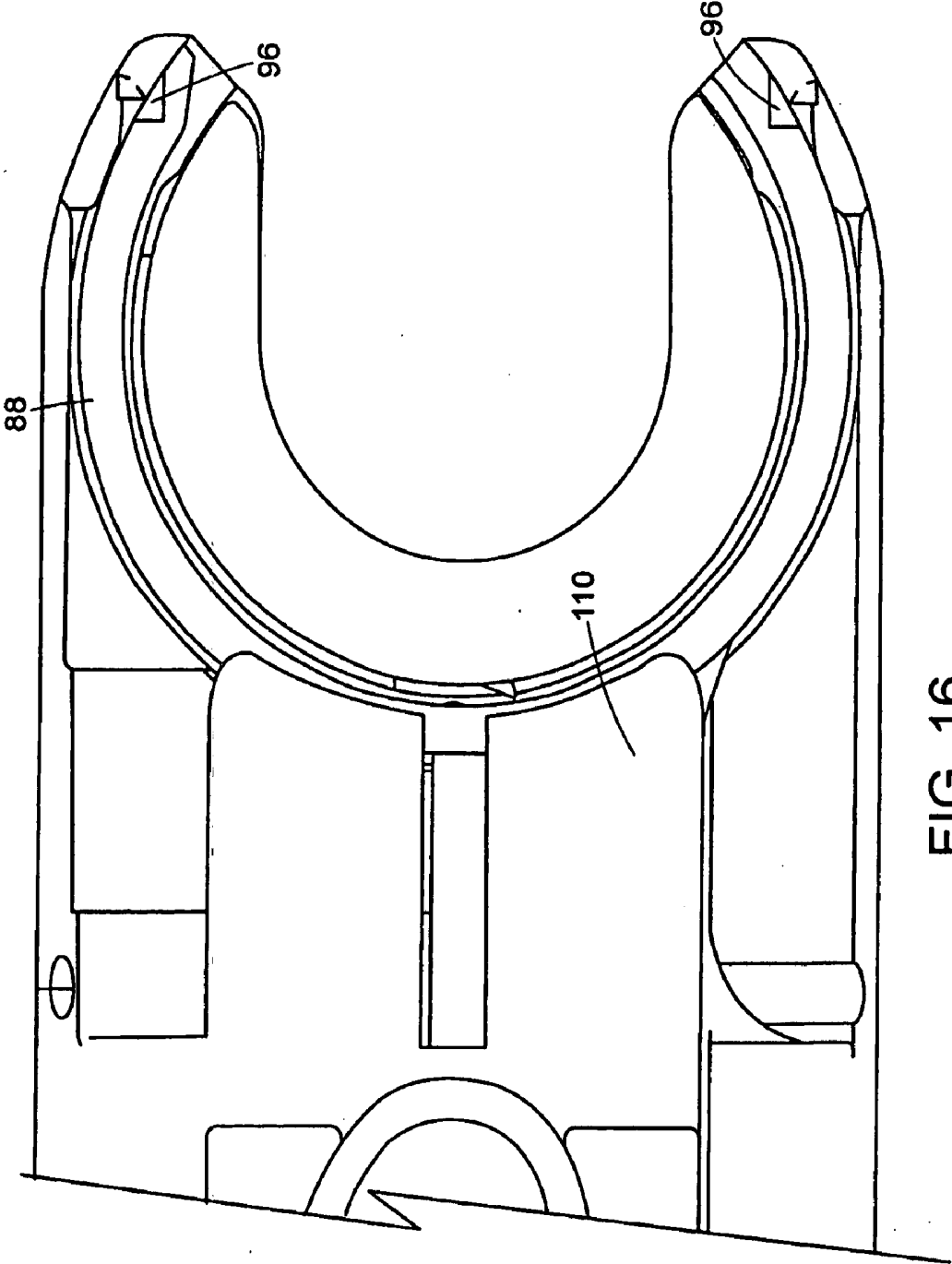

FIG. 16

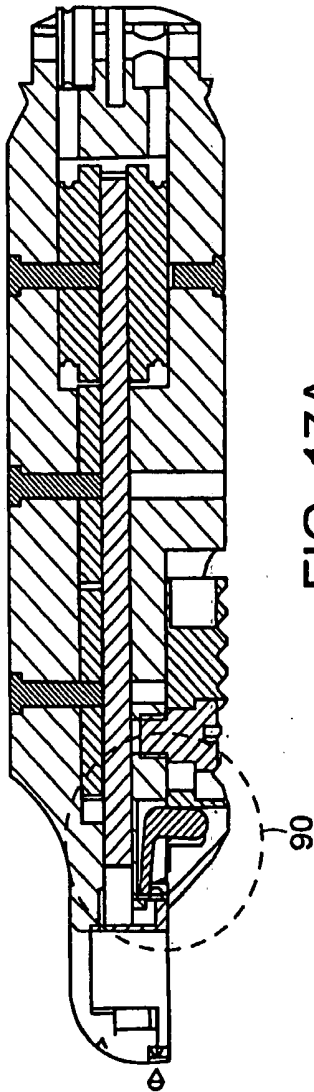

FIG. 17A

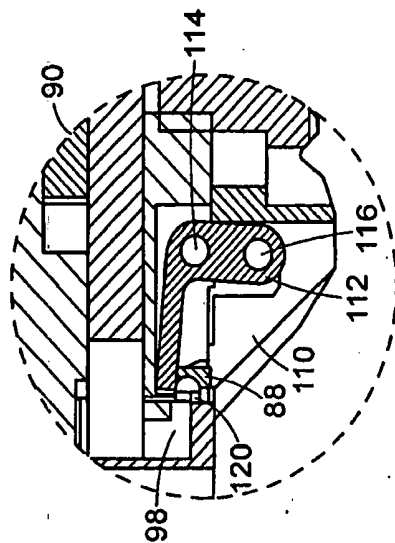

FIG. 17B

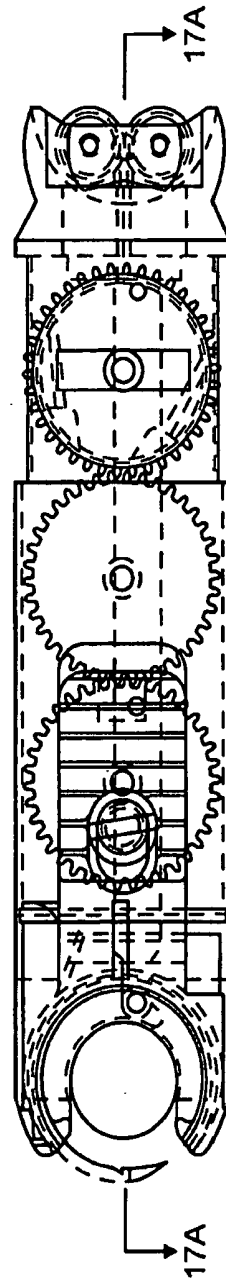

FIG. 17C

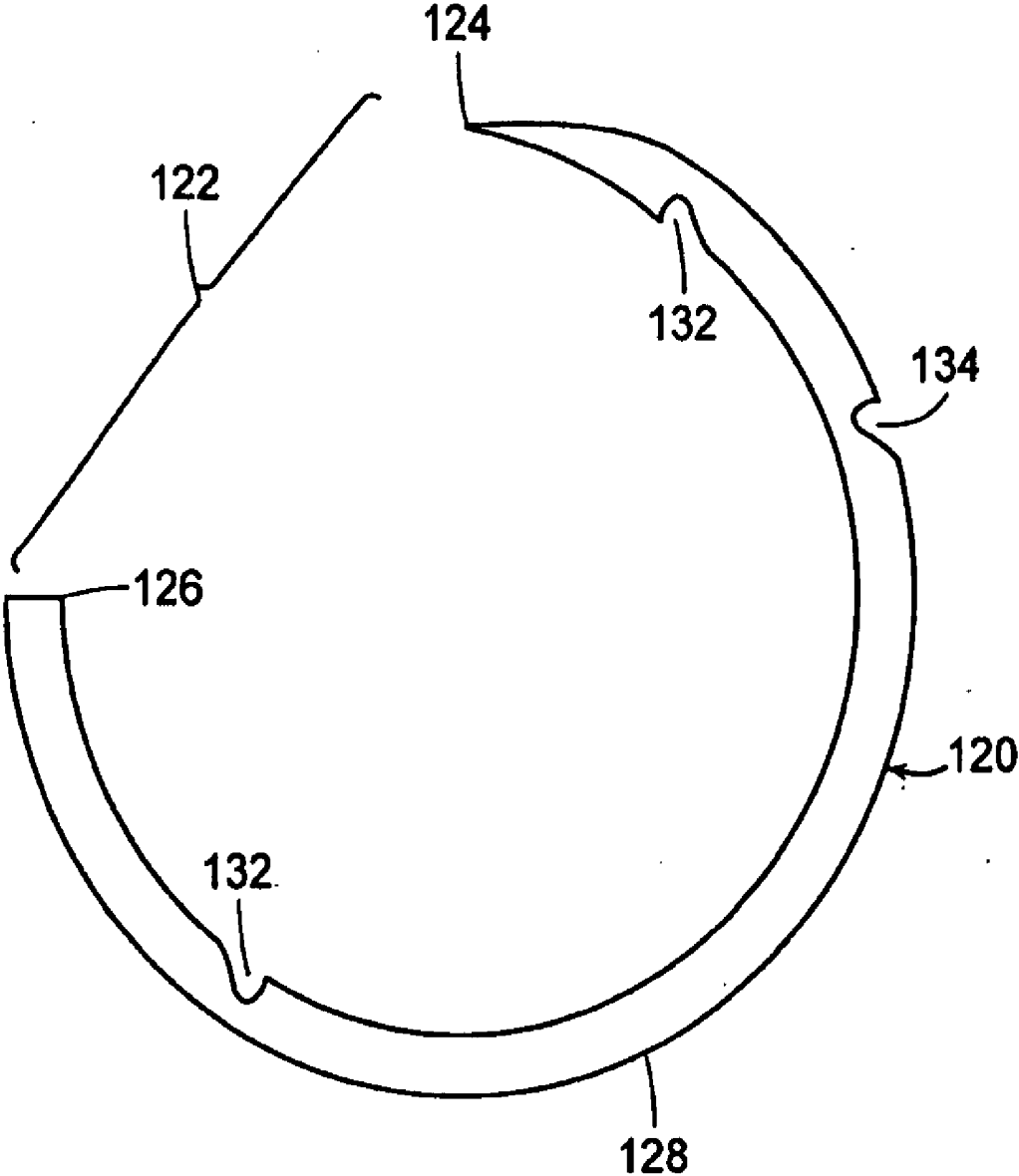
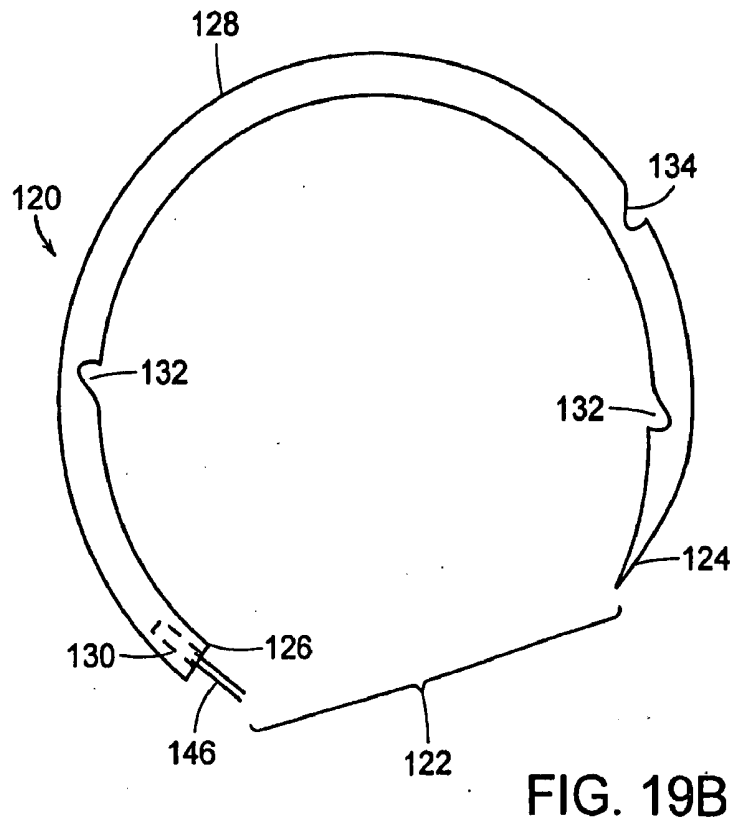
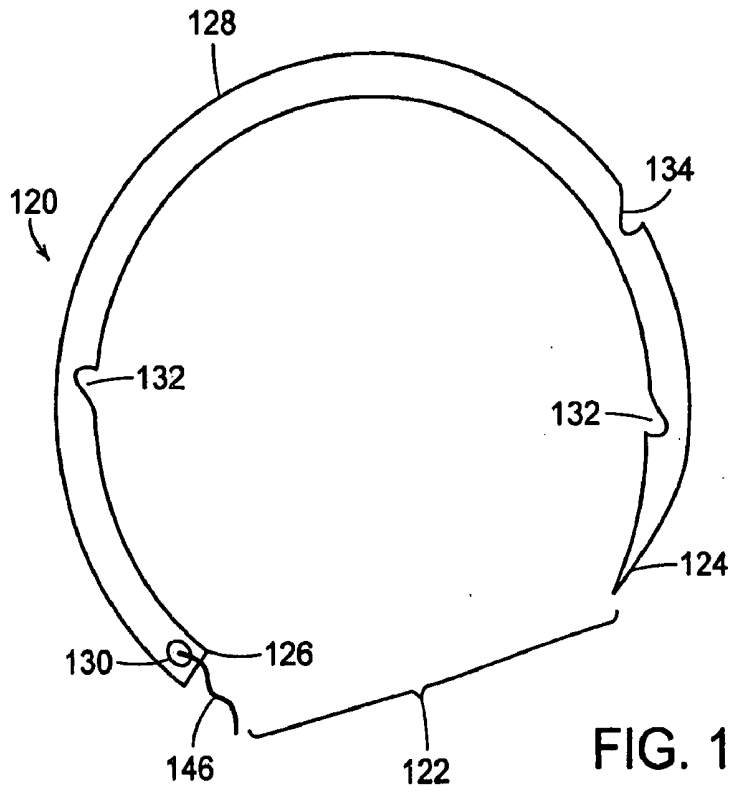

FIG. 18



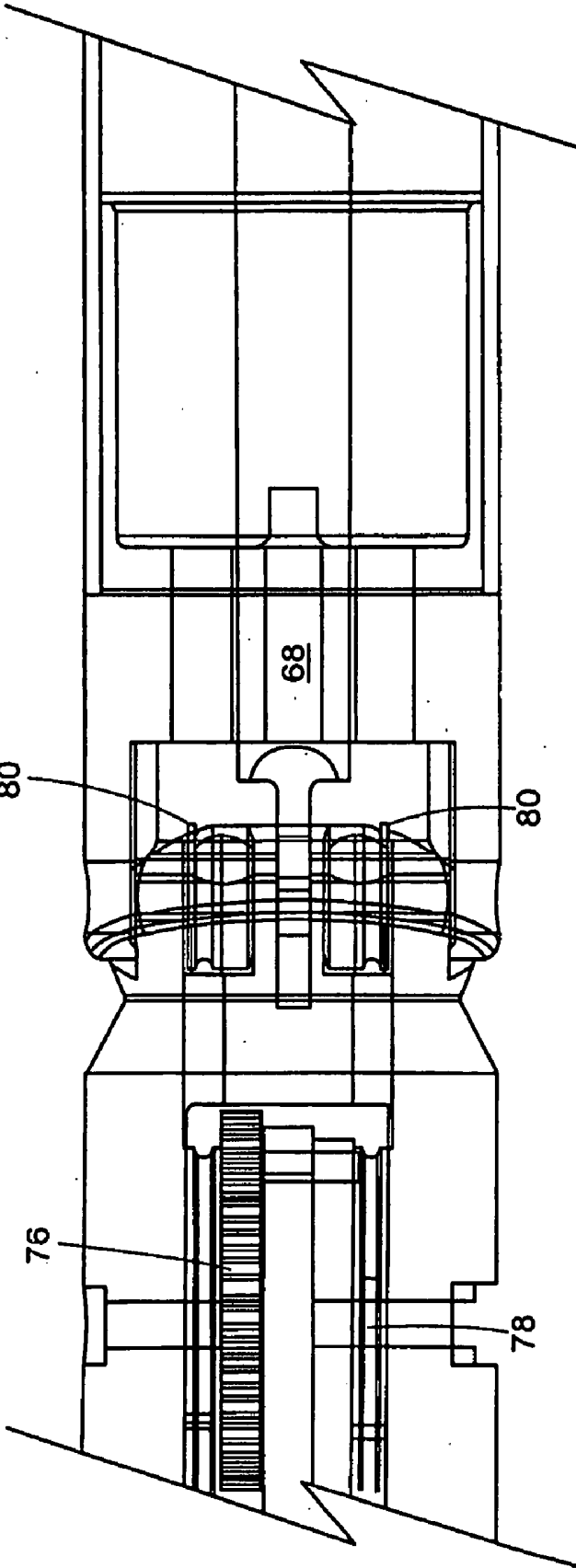

FIG. 20

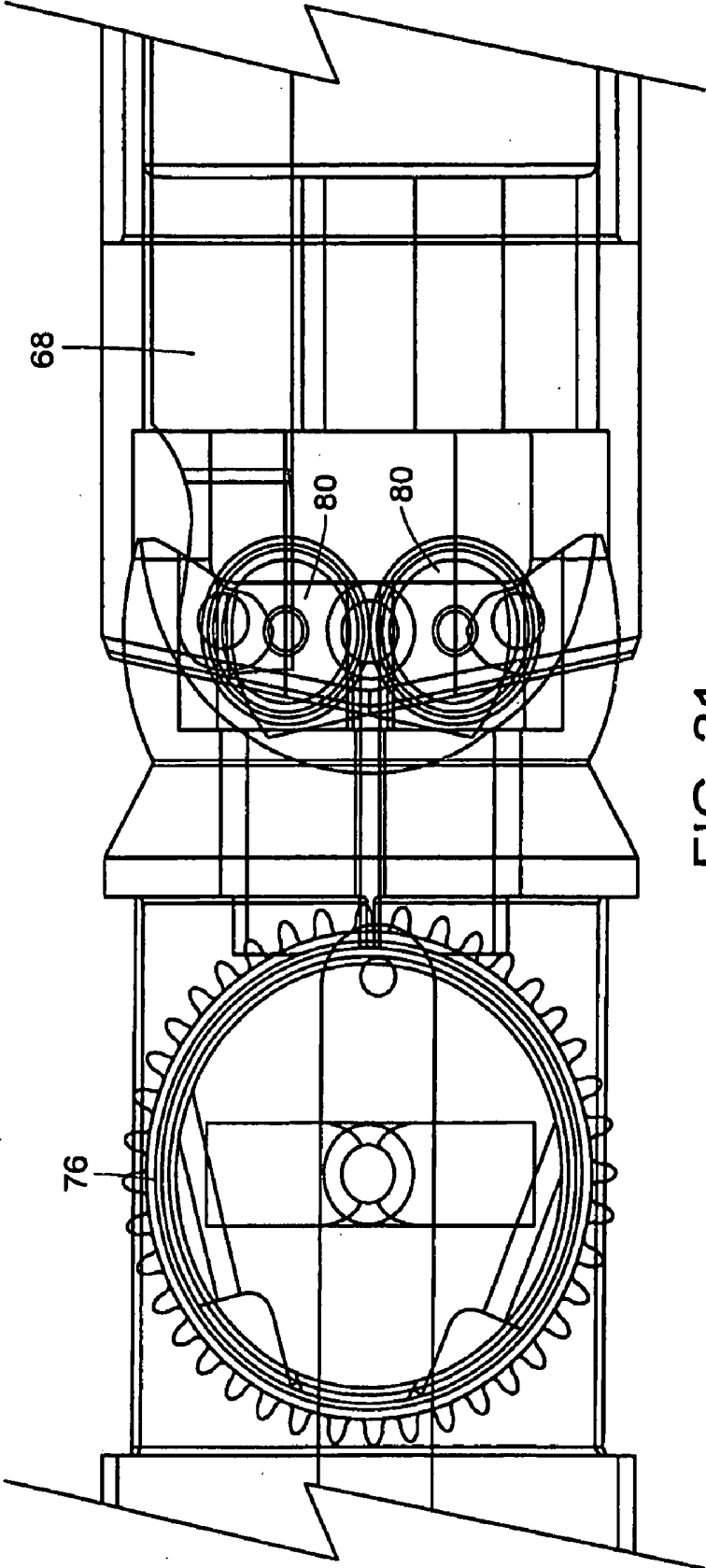

FIG. 21

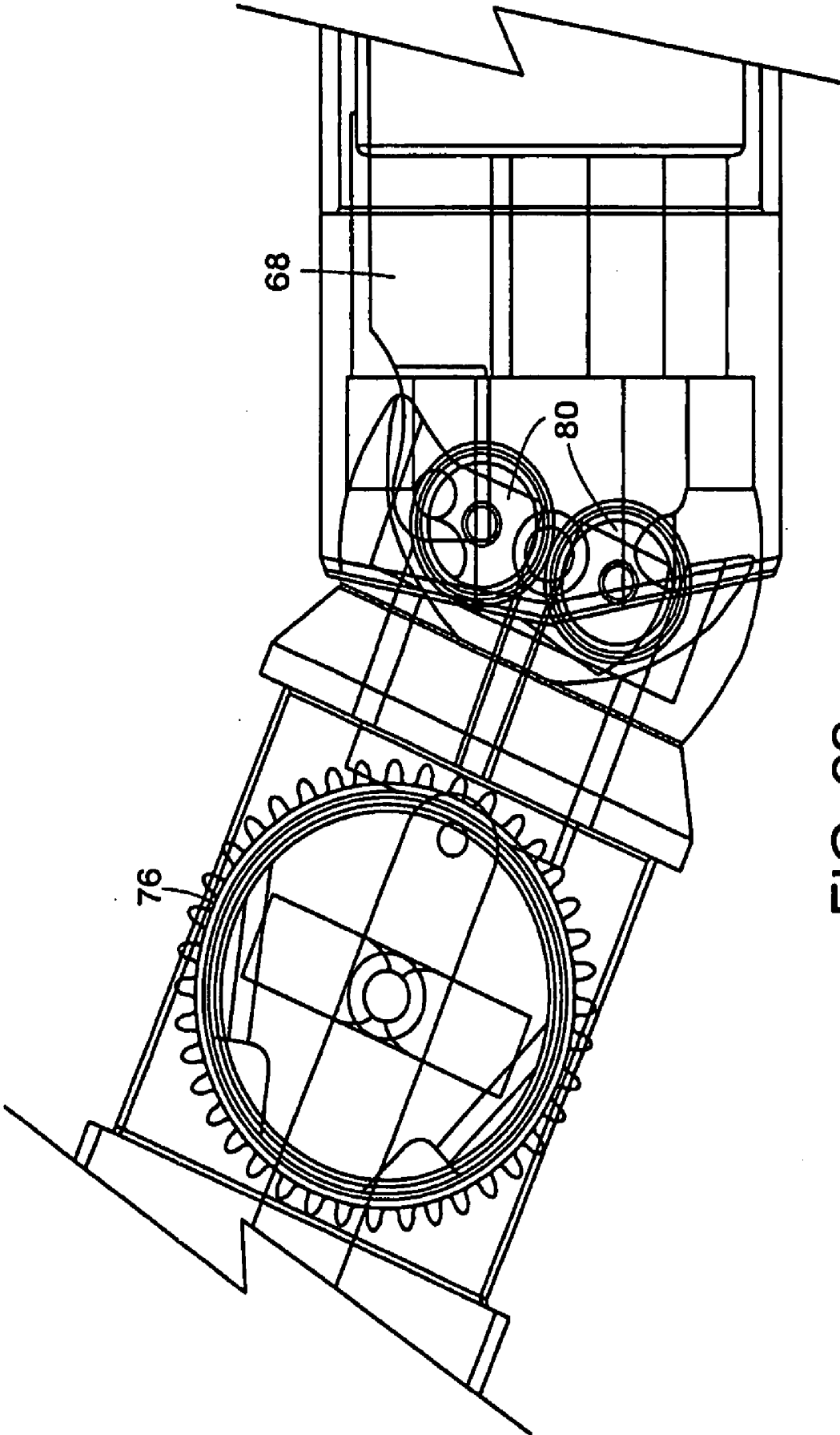

FIG. 22

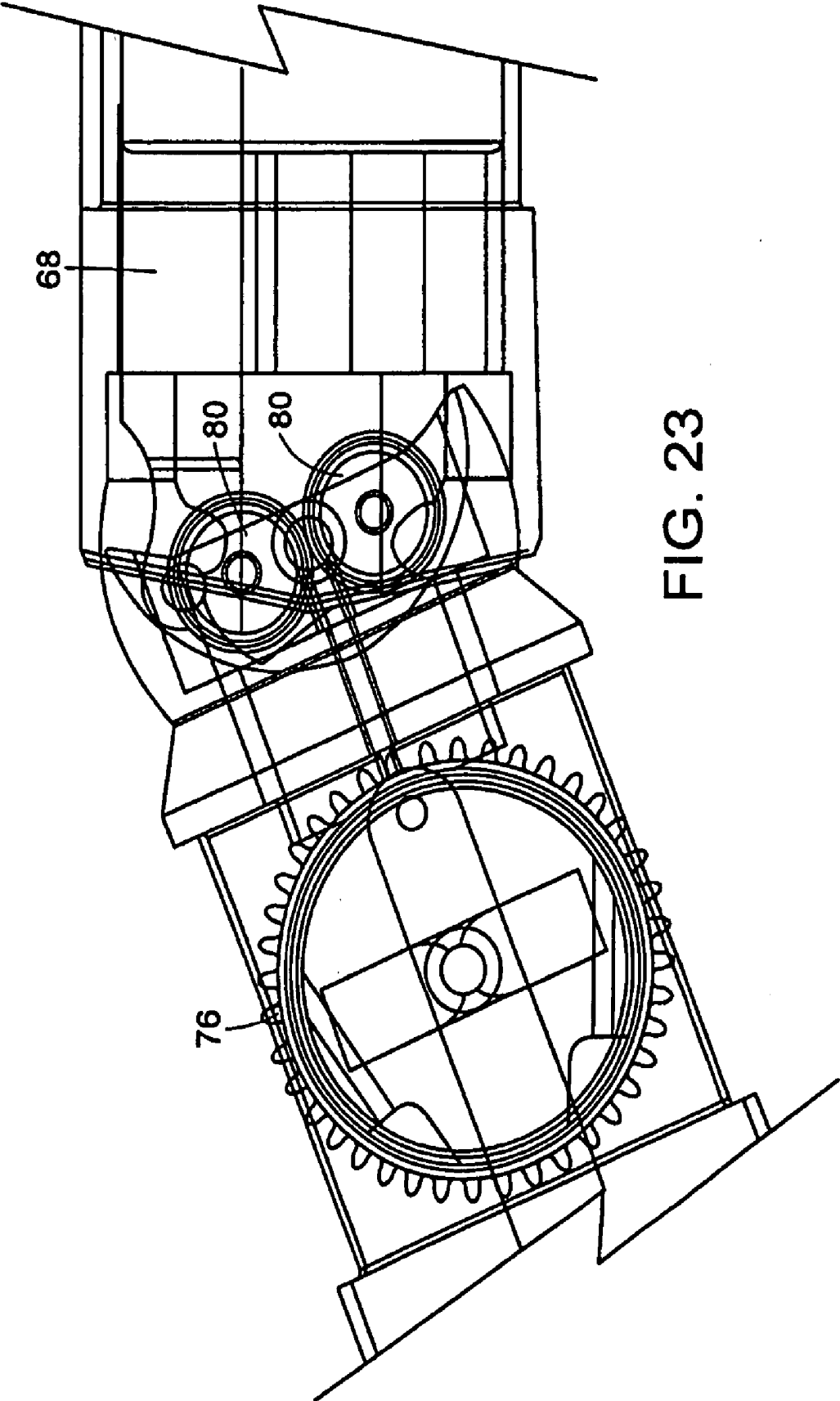

FIG. 23

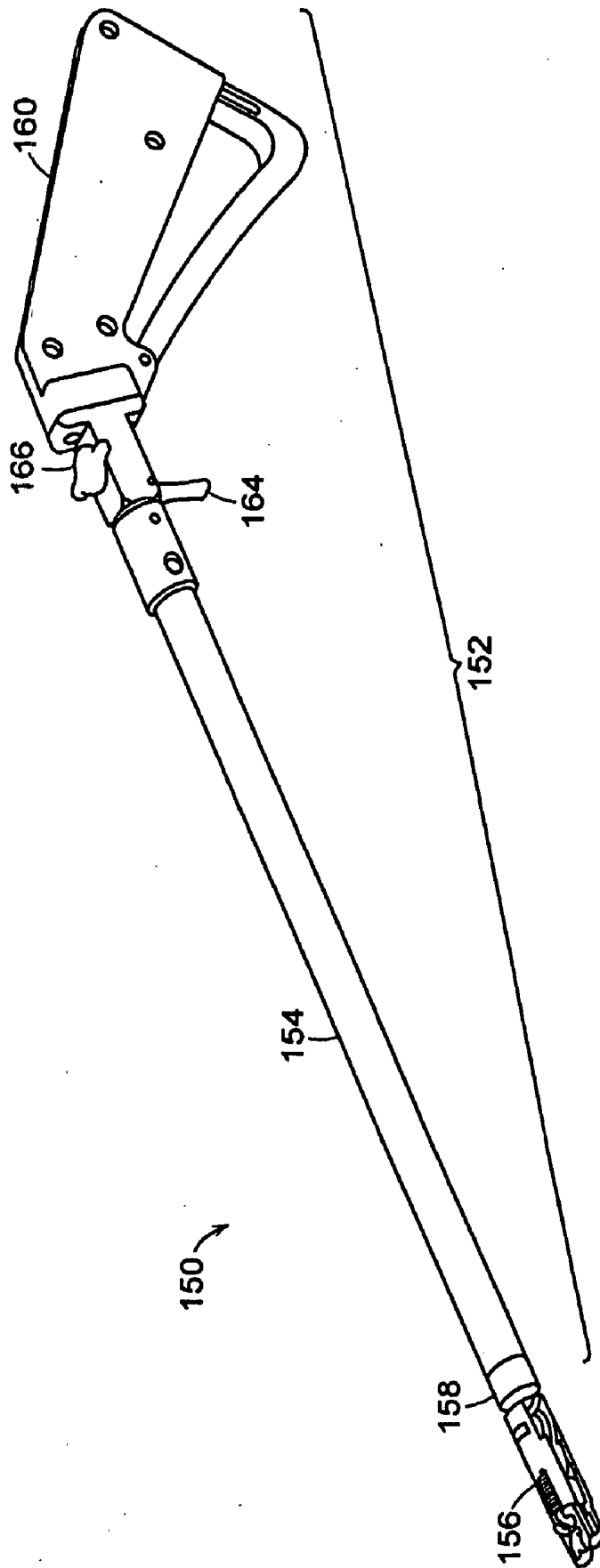

FIG. 24

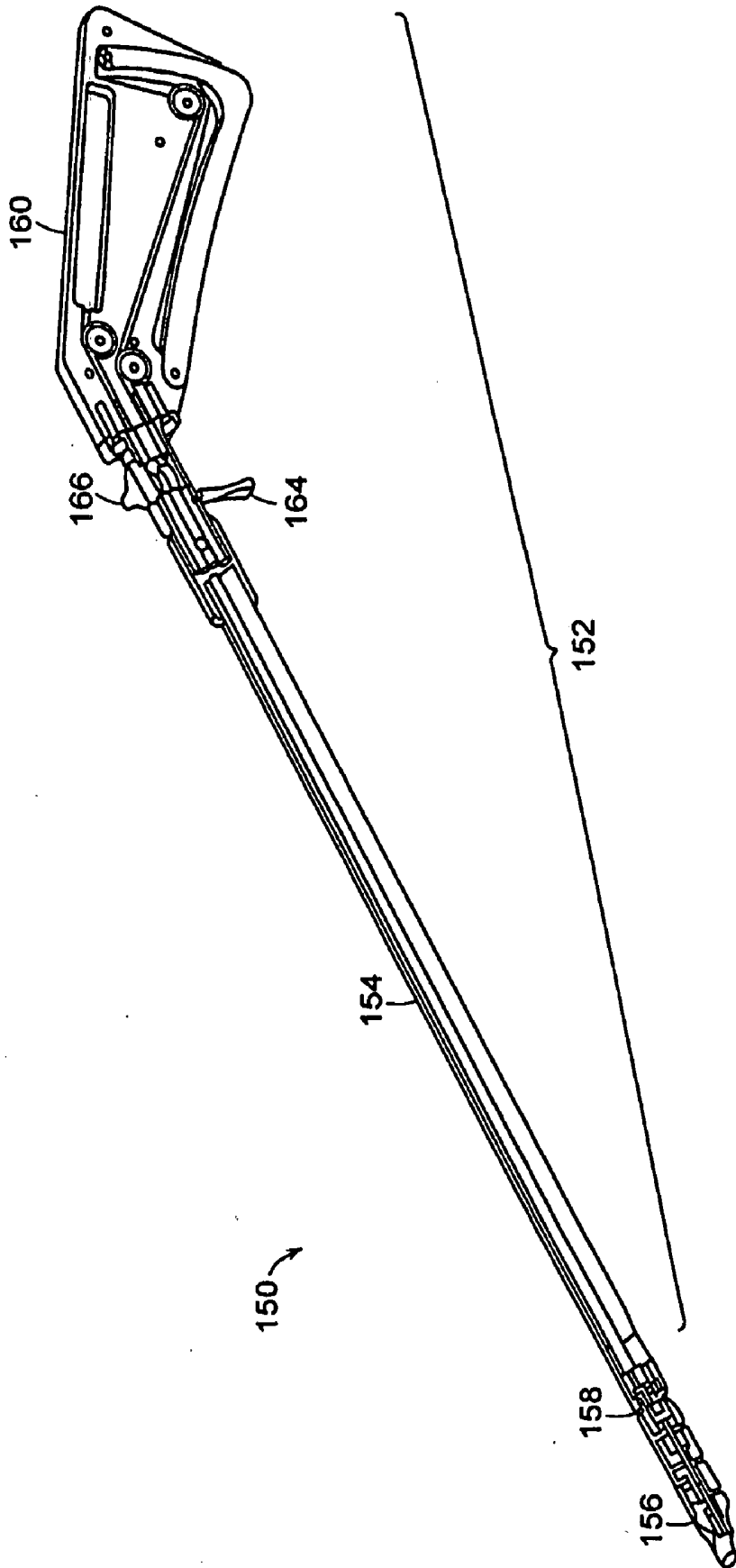

FIG. 25

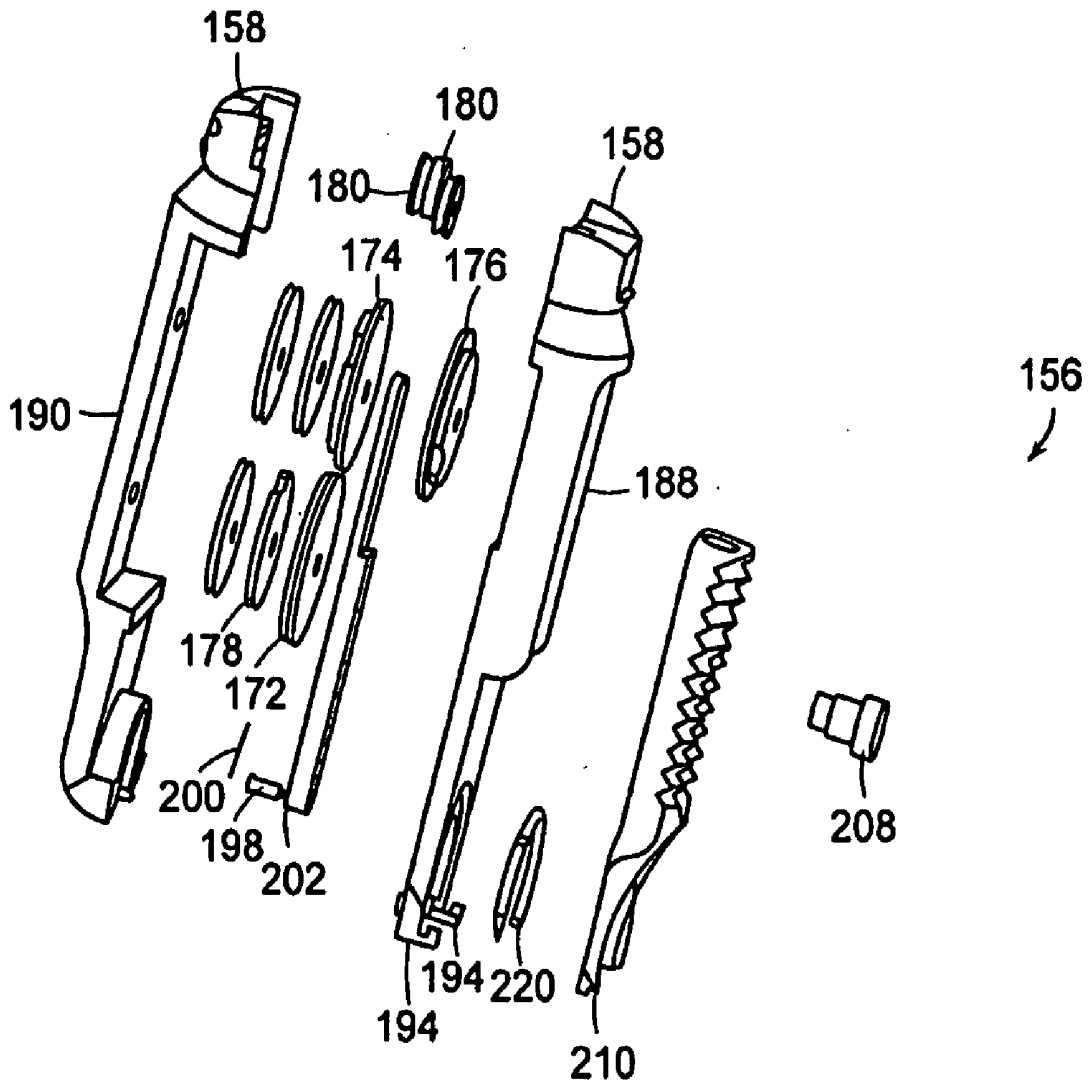

FIG. 26

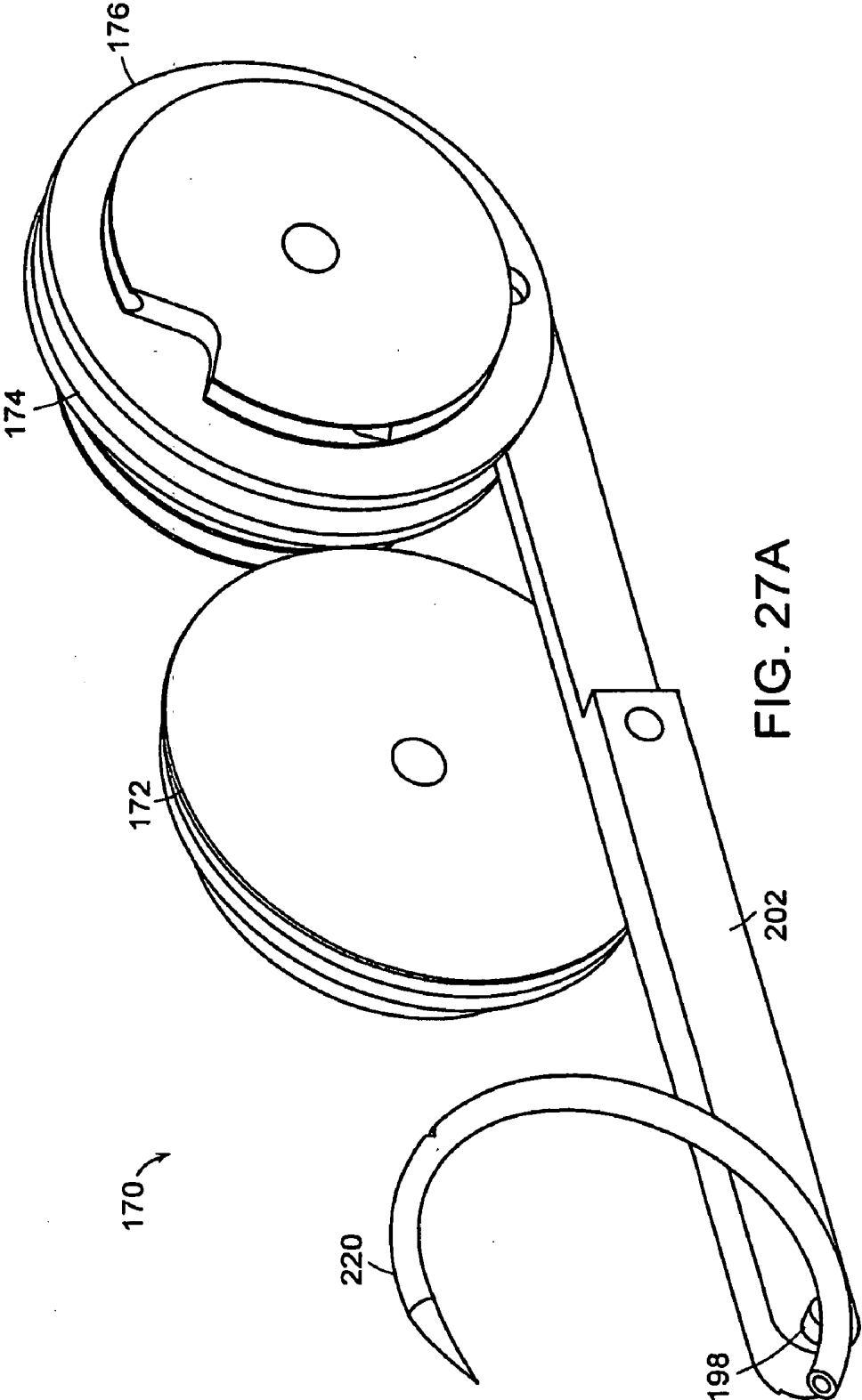

FIG. 27A

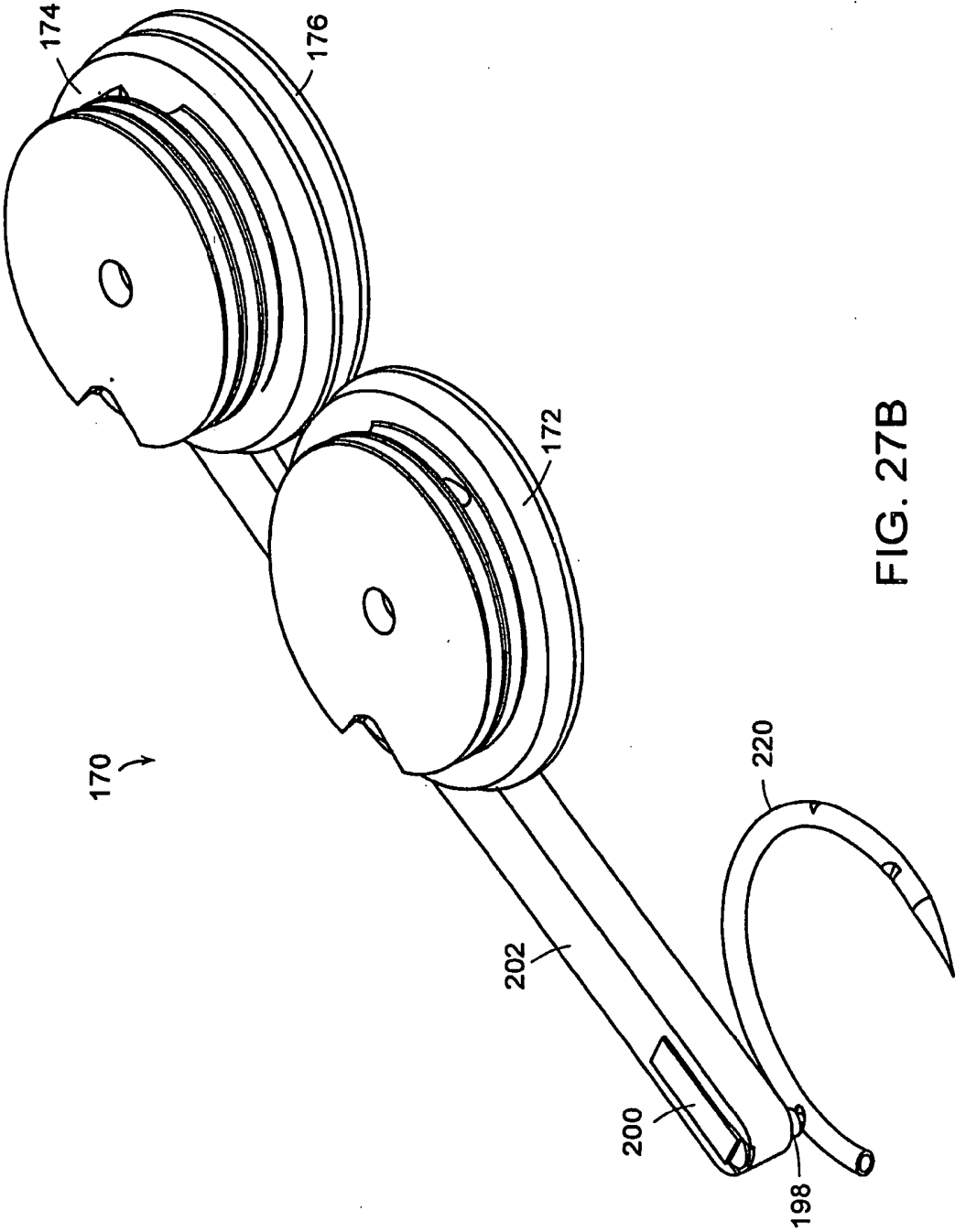

FIG. 27B

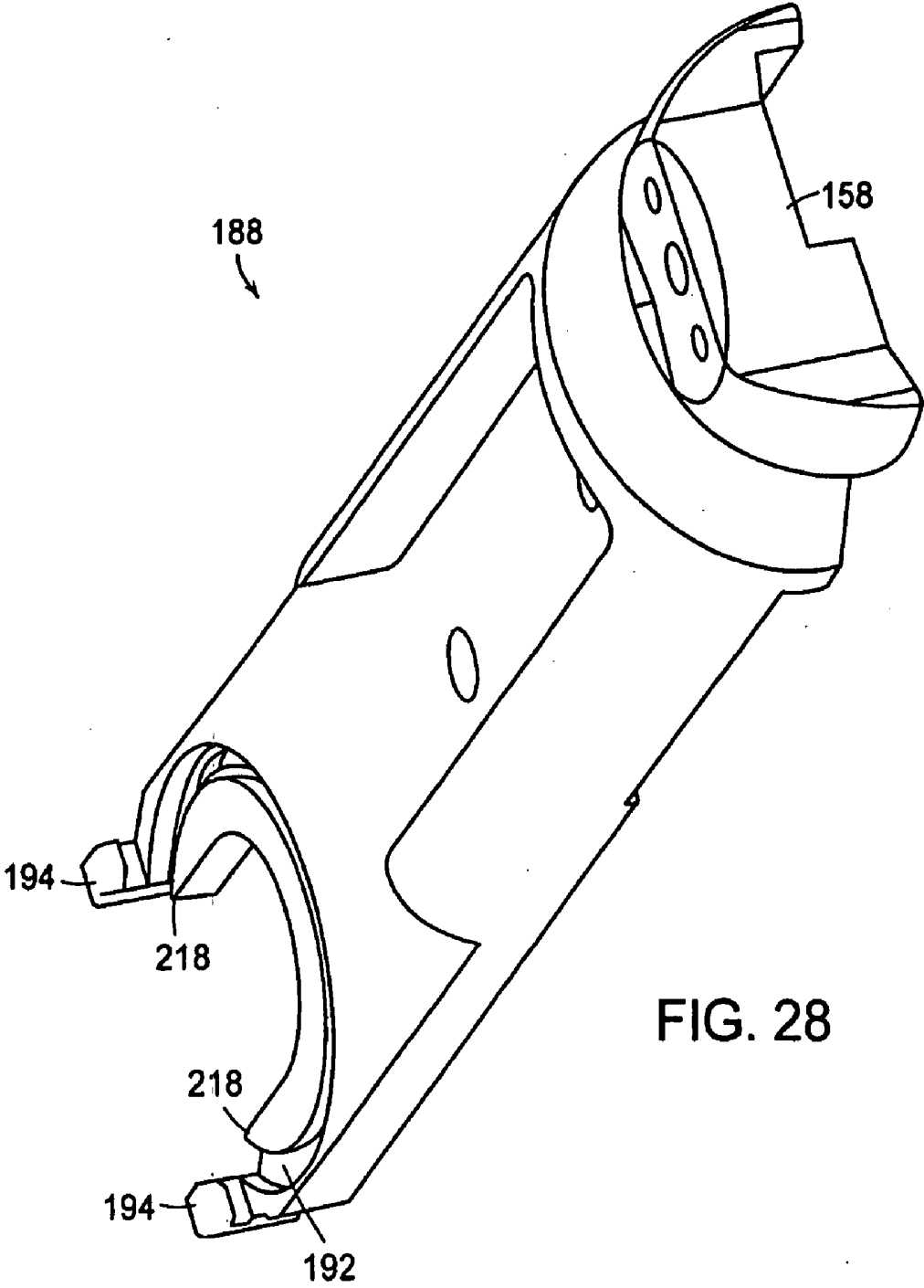

FIG. 28

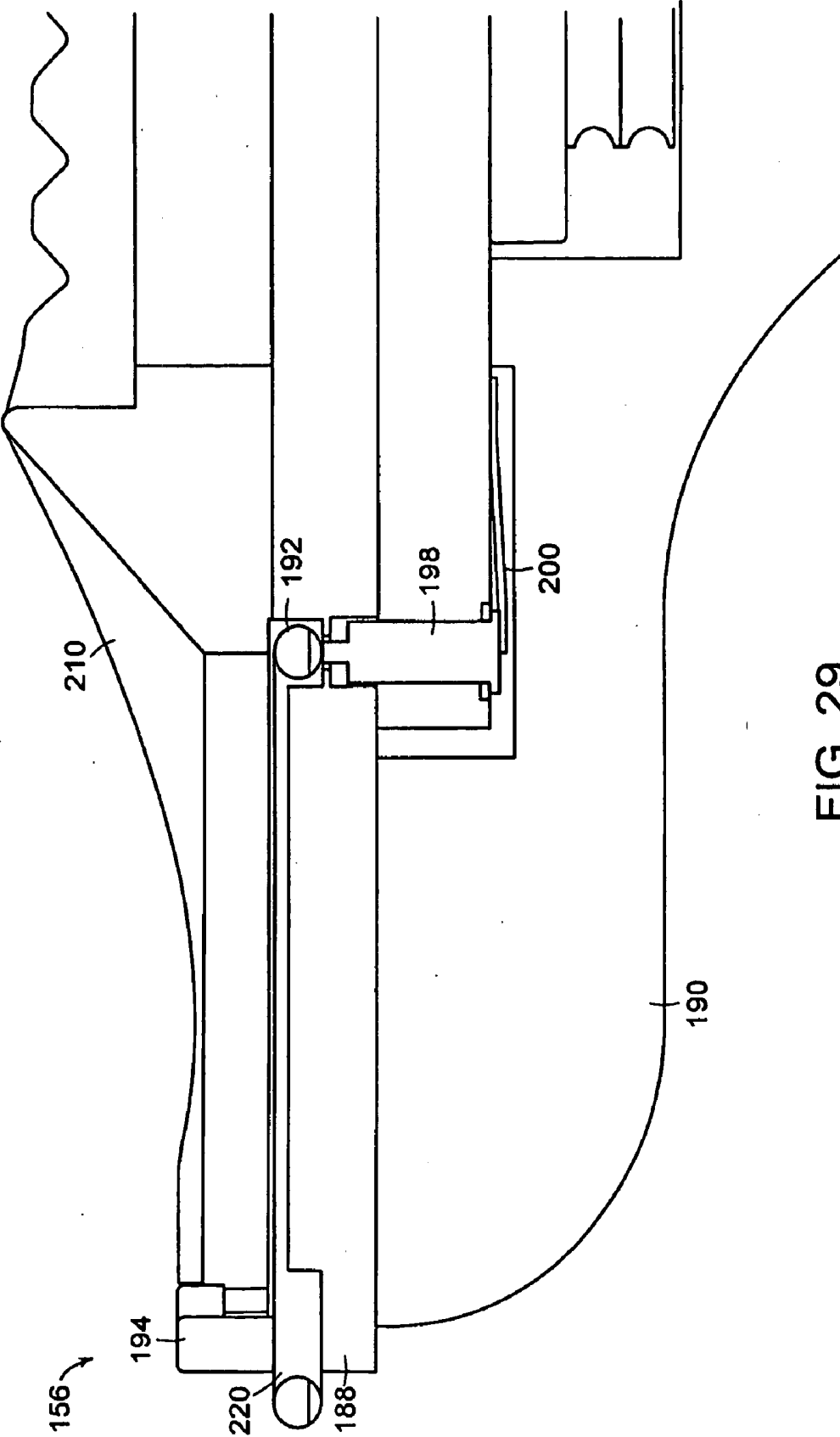

FIG. 29

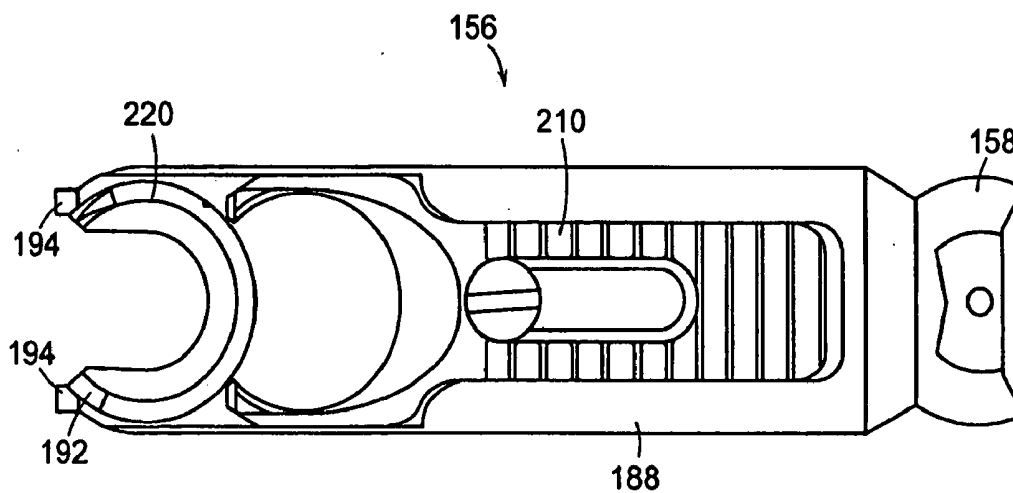

FIG. 30

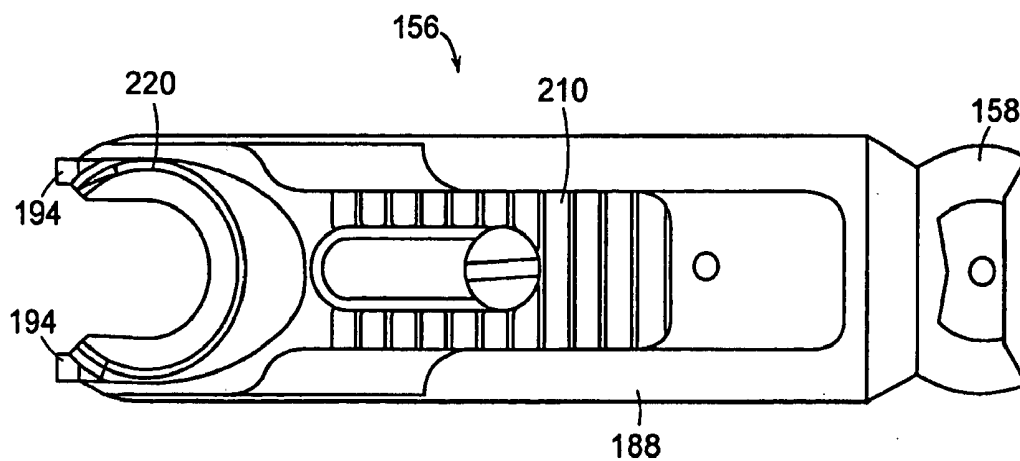

FIG. 31

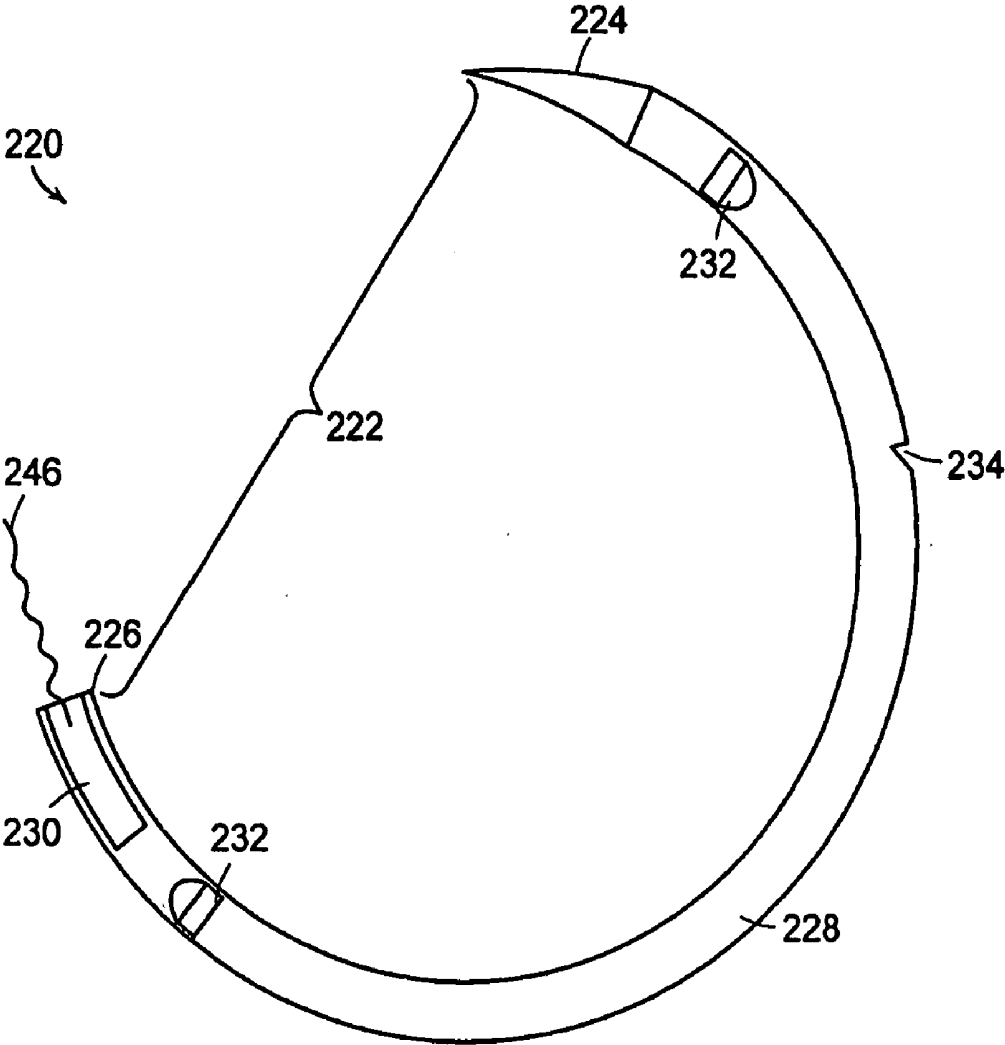

FIG. 32

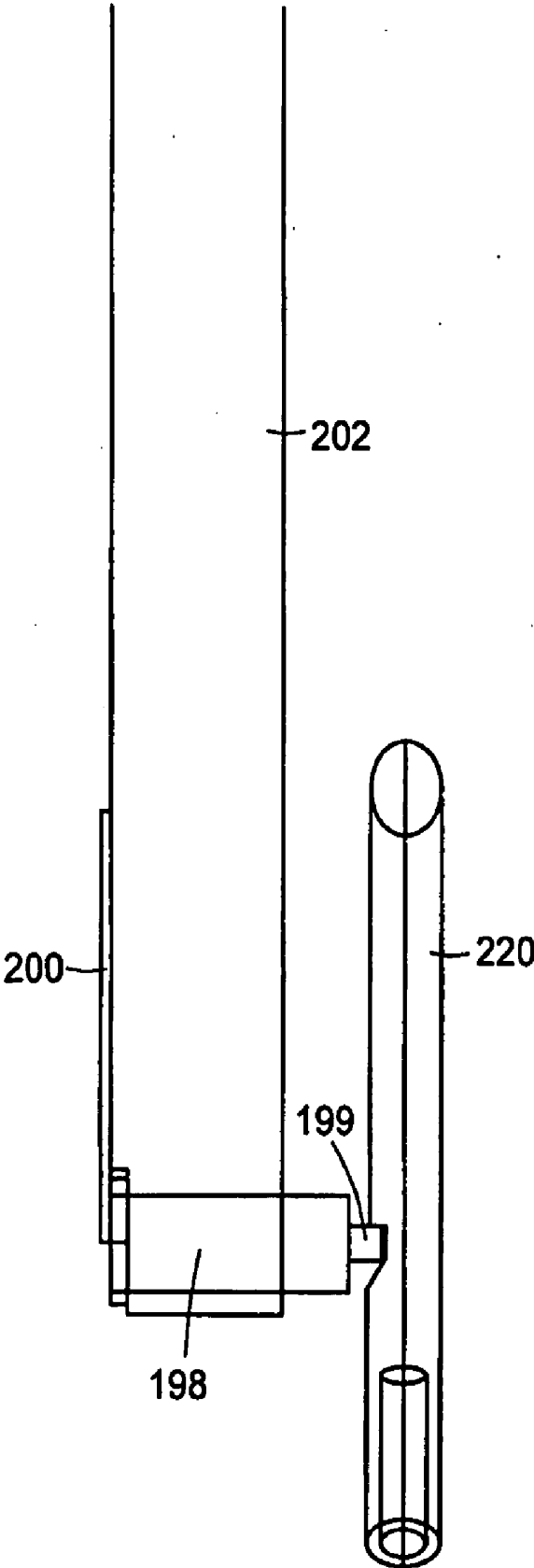

FIG. 33

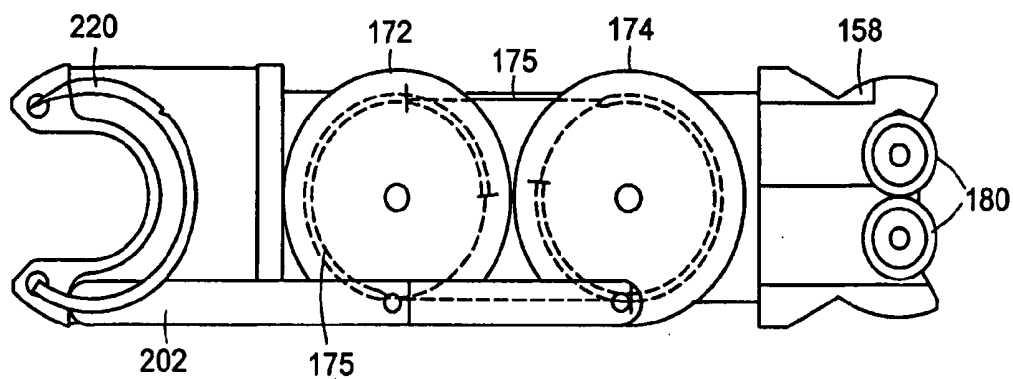

FIG. 34

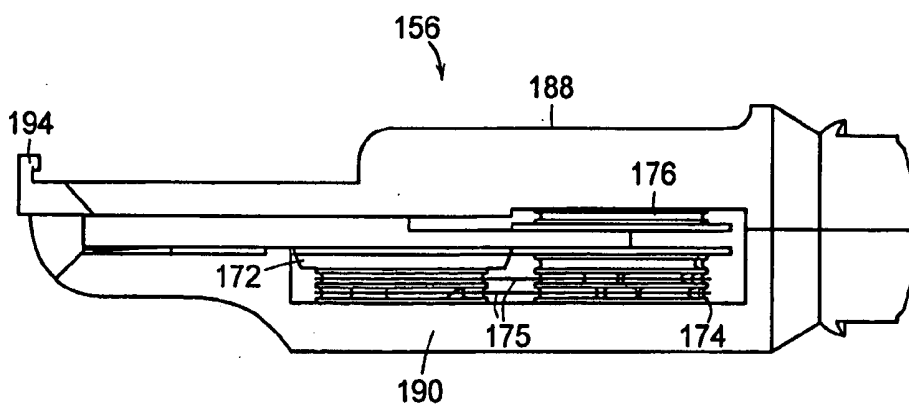

FIG. 35

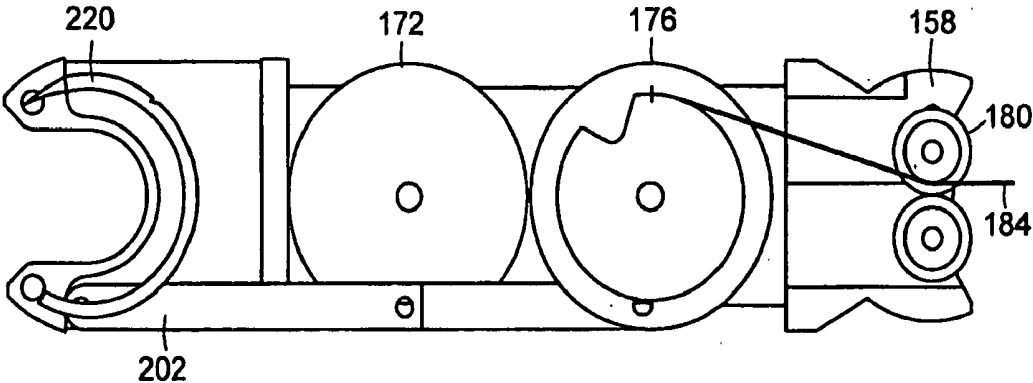

FIG. 36

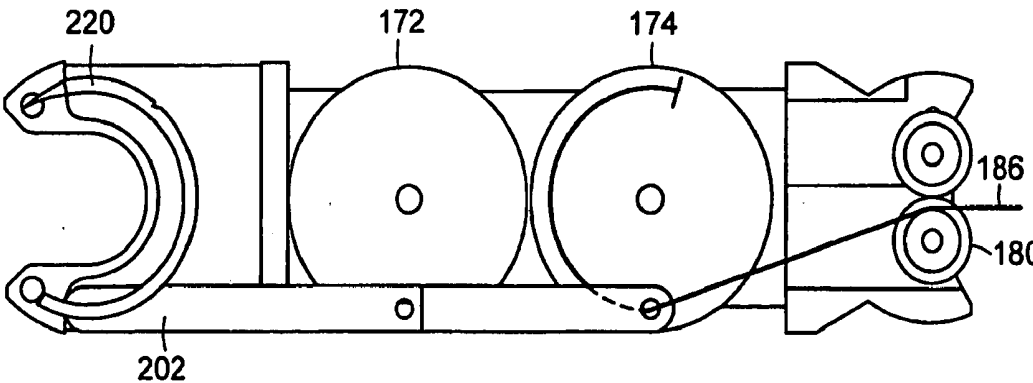

FIG. 37

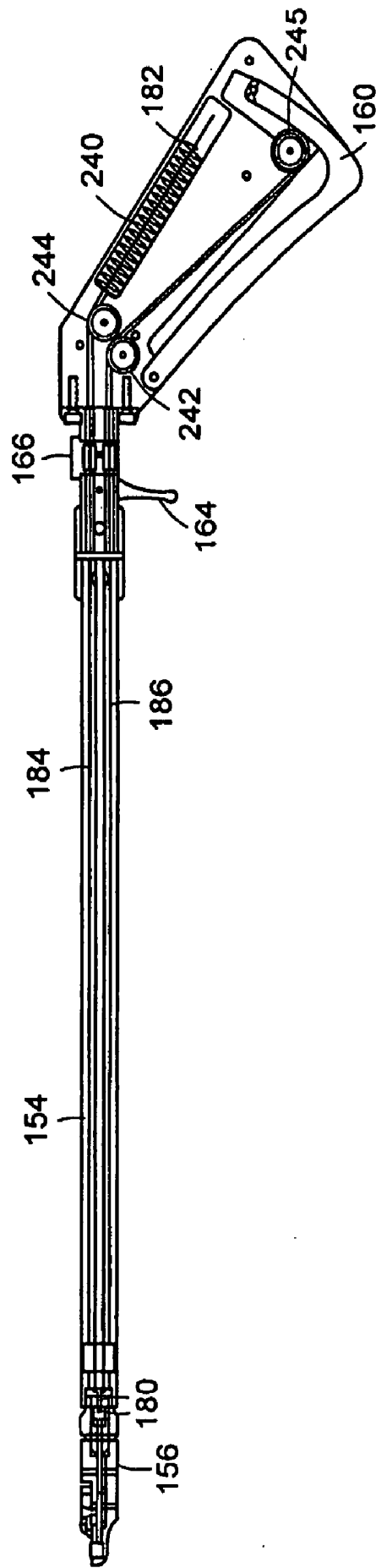

FIG. 38

APPARATUS AND METHOD FOR MINIMALLY INVASIVE SUTURING

RELATED APPLICATIONS

[0001] This application claims priority to U.S. patent application Ser. No. 11/231,135, filed Sep. 20, 2005, U.S. Provisional Application Ser. No. 60/611,362, filed Sep. 20, 2004, U.S. patent application Ser. No. 11/387,127, filed Mar. 22, 2006, U.S. patent application Ser. No. 10/127,254, filed Apr. 22, 2002, now U.S. Pat. No. 6,923,819, U.S. Provisional Application Ser. No. 60/298,281, filed on Jun. 14, 2001 and U.S. Provisional Application Ser. No. 60/939,887, filed May 24, 2007. Each of these applications is incorporated by reference herein in its entirety.

FIELD

[0002] The embodiments disclosed herein relate to a medical device for suturing tissue, and more particularly to a device for the manipulation and control of a suturing needle during minimally invasive suturing, and methods for using such a device for suturing tissue.

BACKGROUND

[0003] Minimally invasive surgery (MIS) has allowed physicians to carry out many surgical procedures with less pain and disability than conventional, open surgery. Unlike conventional open surgery, where the surgical site is readily accessible through a large incision, enabling the surgeon to easily visualize and manipulate both tissue and instruments, MIS requires the surgeon to operate remotely by inserting and manipulating instruments through small punctures (“keyhole surgery”) or through natural orifices, including the vagina, the esophagus, or the anus.

[0004] In MIS, a small puncture is typically made in the body. Medical instruments are then inserted through a cannula. A cannula has a small inside diameter, typically 5-10 millimeters (mm), and sometimes up to 20 millimeters (mm) or more. A number of such cannulas are inserted into the body for any given operation. Minimally invasive surgical instruments are necessarily smaller, and are also generally longer and therefore are more difficult to manipulate with precision.

[0005] Perhaps the most problematic surgical task in MIS is suturing. Suturing requires coordinated manipulation with both hands of small needles and sutures that are difficult to visualize (particularly when only indirect, two-dimensional video imaging is available) as well as the several instruments (including needle-drivers and pick-up forceps) ordinarily used to suture by hand. In an environment characterized by limited space, limited visualization, and limited mobility, many surgeons find minimally invasive suturing by hand an extremely difficult, often virtually impossible, surgical task.

[0006] In the preferred method of suturing by hand, a grasping forceps (“needle driver”) is held by the surgeon and is used to grip a curved needle near the needle’s tail. Pronation of the surgeon’s wrist drives the needle into the tissue. When the point of the curved needle emerges from the tissue, the surgeon releases the needle from the grip of the needle driver and grasps the point with another forceps (“pick-ups”). The surgeon then pulls the curved needle by the needle point, preferably in a circular path following the arc of the needle’s curvature to follow the most atraumatic path through the tissue, until the entire length of the needle has exited the tissue. Each time a stitch is placed, the curved needle is thus

driven around in a complete circular arc. Individual (interrupted) stitches are placed by tying off the suture following the placement of each stitch. Running (continuous) stitches are placed by repeatedly driving the curved needle in a complete circular arc repeatedly until the desired length of suture and number of stitches has been placed. In order to place additional interrupted or continuous stitches, the surgeon must let go of the point of the needle and re-grasp the needle near the needle’s tail.

[0007] In the manual suturing technique described above, the direct handling of the needle can result in accidental needle pricks through a surgeon or nurse’s gloves, posing a potential risk of infection for the surgeon, nurse, staff, and patient, or cause the needle to become contaminated with pathogenic bacteria that can cause onset of infection at the site of the sutures. There is also a risk of the needle penetrating internal organs or vessels and causing a serious, and often fatal infection.

[0008] Various devices for suturing for MIS are described in U.S. Pat. No. 5,643,295 entitled “Methods and Apparatus for Suturing Tissue”; U.S. Pat. No. 5,665,096 entitled “Needle Driving Apparatus and Methods of Suturing Tissue”; U.S. Pat. No. 5,665,109 entitled “Methods and Apparatus for Suturing Tissue”; U.S. Pat. No. 5,759,188 entitled “Suturing Instrument with Rotatably Mounted Needle Driver and Catcher”; U.S. Pat. No. 5,860,992 entitled “Endoscopic Suturing Devices and Methods”; U.S. Pat. No. 5,954,733 entitled “Suturing Instrument with Rotatably Mounted Needle Driver and Catcher”; U.S. Pat. No. 6,719,763 entitled “Endoscopic Suturing Device”; and U.S. Pat. No. 6,755,843 entitled “Endoscopic Suturing Device”, all of which are incorporated by reference in their entireties for the teachings therein.

[0009] Assignees’ U.S. Pat. No. 5,437,681, U.S. Pat. No. 5,540,705 and U.S. Pat. No. 6,923,819 disclose a suturing device with thread management comprising a protective cartridge, suturing needle and needle rotation drive, the disclosures of which are hereby incorporated by reference. The devices described in the above-mentioned patents and patent application comprise a mechanism for driving a protected needle however, the needle is rotated about an axis that is parallel to the axis of the device. In addition, the orientation and size of the suturing device makes it difficult to visualize and cumbersome to use for MIS.

[0010] Therefore, there remains a need in the art for a minimally invasive suturing device that is easily manipulated within the small diameter of the cannula; functions in an environment characterized by limited space, limited visualization, and limited mobility; mimics the preferred method of suturing used by surgeons; permits the surgeon to secure and tie knots quickly and with controlled tension; places continuous stitches; and protects user’s from accidental needle sticks during needle handling, as well as internal organs and vessels, from inadvertent needle-pricks.

SUMMARY

[0011] Devices and methods for minimally invasive suturing of tissue internal to a body are disclosed herein.

[0012] According to aspects illustrated herein, there is provided a medical device for closing openings internal to a patient’s body, which closely emulates or replicates the manual suturing actions carried out by a surgeon. The device offers several advantages over conventional methods used by surgeons for suturing tissue during minimally invasive sur-

gery in that the device provides a hand-held suturing instrument of relatively simple mechanical construction that requires no external motive source. The presently disclosed embodiments provide relative ease of operation for the surgeon with only one hand.

[0013] According to aspects illustrated herein, there a suture head assembly may be removably attached to an actuator mechanism of the suturing device. The diameter of the device is small enough to fit into a typical cannula, thus making the device extremely easy to maneuver, as well as suture, during endoscopic or other MIS procedures. Also, the suture head assembly of the device can be laterally articulated to the left of center, to the right of center, up, and down, once inside the cannula, which is ideal for use in the course of endoscopic surgery, including laparoscopy, thoracoscopy and arthroscopy, as well as other less-invasive surgical procedures.

[0014] The device of the present disclosed embodiments closely emulates or replicates the manual suturing actions carried out by a surgeon. For example, during manual suturing by hand, the needle is held in forceps and travels in a circular arc with no obstructions anywhere in the interior of the arc. The design of the suturing device of the present disclosed embodiments allows for a lack of obstruction in the center of the arc of the needle during suturing. In other words, there is no hub at the center of the circular arc of the suturing needle. The entire area within the circular arc of the needle is unobstructed. This allows for the user to have better visualization during operation, unlike the present mechanical suturing methods, while maintaining control over needle movement.

[0015] The “locomotive-type” drive mechanism of the device of the presently disclosed embodiments enables the small diameter of the device and affords better visualization during operation because of the lack of a hub. There are many benefits afforded by the design of the suturing device of the presently disclosed embodiments, including, but not limited to, more tissue can fit into the device, thus enabling a bigger bite of tissue and a more secure suture; the device can be used to ligate, that is, place a loop of suture around a blood vessel, duct, or other tubular structure; and the device can be inserted further into smaller incisions/openings (one side of the aperture can be inserted deeply, for example).

[0016] A benefit provided by the suturing device of the presently disclosed embodiments is that the device enables maneuvering a suturing material through a tissue incision in a manner substantially similar to the way a surgeon would do so by hand. In particular, the suturing device first pushes a suturing needle from the tail of the needle and drives the point of the needle through the tissue. The device then picks up the point of the needle that passed through the tissue, and pulls the remainder of the suturing needle and the suture attached to the suturing needle through the tissue. The suturing needle thus consistently follows the arc of the needle's own curve, which is the preferred method of suturing, in the most atraumatic way of passing a needle through tissue. A benefit provided by the suturing device of the presently disclosed embodiments is the ability of the suturing needle to pull the suturing thread entirely through the tissue segments being closed, following each stitch. When using the suturing device of the presently disclosed embodiments, no ancillary instruments or tools such as needle holders, pick-up forceps or the like are needed to complete the stitch. A forceps can be used to tighten the knots.

[0017] According to aspects illustrated herein, there is provided a suturing device that includes a suturing needle that is protected by a housing, the suturing needle is not exposed to or handled directly by the user, thereby preventing inadvertent needle sticks. The configuration of the suturing device of the presently disclosed embodiments also protects against inadvertent penetration of internal organs or vessels by the needle, since the housing acts as a shield between the organs and the needle.

[0018] The suturing device of the presently disclosed embodiments is useful for suturing tissue internal to a body. The device includes an elongated barrel having a proximal end, a distal end, and a longitudinal axis therebetween; a suture head assembly extending from the distal end of the elongated barrel; a suturing needle having a pointed end and a blunt end, the suturing needle capable of rotating about an axis approximately perpendicular to a longitudinal axis of the elongated barrel, wherein the pointed end of the suturing needle is positioned within the suture head assembly prior to and after rotation of the suturing needle; and an actuator extending from the proximal end of the elongated barrel to actuate a drive mechanism having a needle driver for engaging and rotating the suturing needle.

[0019] According to aspects illustrated herein, there is provided a method for suturing tissue during minimally invasive surgery that includes (a) engaging a cartridge to a suture head assembly at a distal end of a suturing device, the cartridge having a protective housing and a suturing needle with a pointed end and a blunt end; (b) introducing the distal end of the suturing device into a body cavity; (c) positioning an opening in the cartridge to span a plurality of separated tissue segments or a single tissue segment; (d) activating an actuator coupled to a drive mechanism that engages the suturing needle to cause rotational movement of the suturing needle about an axis approximately perpendicular to a longitudinal axis of the suturing device and advance the suturing needle through the plurality of separated tissue segments or the single tissue segment; (e) pulling a suturing material attached to the suturing needle through the plurality of separated tissue segments or the single tissue segment forming a stitch; and repeating steps (c) through (e) to cause a plurality of stitches to be placed through the separated tissue segments or the single tissue segment.

[0020] According to aspects illustrated herein, there is provided a method for suturing tissue during minimally invasive surgery that includes (a) engaging a suturing needle with a pointed end and a blunt end to a suture head assembly at a distal end of a suturing device, the suture head assembly includes a curved track, whereby the suturing needle follows a curved path along the track during rotation of the suturing needle, and a latch that provides a protective housing for the suturing needle; (b) introducing the distal end of the suturing device into a body cavity; (c) positioning an opening in the needle holder assembly to span a plurality of separated tissue segments or a single tissue segment; (d) activating an actuator coupled to a drive mechanism that engages the suturing needle to cause rotational movement of the suturing needle about an axis approximately perpendicular to a longitudinal axis of the suturing device and advance the suturing needle through the plurality of separated tissue segments or the single tissue segment; (e) pulling a suturing material attached to the suturing needle through the plurality of separated tissue segments or a single tissue segment forming a stitch; and

repeating steps (c) through (e) to cause a plurality of stitches to be placed through the separated tissue segments or a single tissue segment.

[0021] According to aspects illustrated herein, there is provided a method for suturing tissue during minimally invasive surgery that includes inserting a distal end of a suturing device having a suturing needle with a pointed end into a body; positioning the suturing needle to span a plurality of separated tissue segments; activating an actuator a first time causing the pointed end of the suturing needle to extend beyond a protective housing of a cartridge to engage the plurality of separated tissue segments; and activating the actuator a second time to cause the suturing needle to complete a revolution and pull a suture extending from the suturing needle through the plurality of separated tissue segments to form a stitch.

[0022] In addition to the advantages discussed above, the suturing device of the presently disclosed embodiments is relatively simple and cost efficient to manufacture. Therefore, the suturing device should find widespread suturing applications that include single stitches or continuous stitches, e.g., spiral, mattress, purse string, etc., that are required to close tissue incisions, attach grafts, or the like.

[0023] These and other advantages of the presently disclosed embodiments will be obvious through the embodiments described hereinafter. The presently disclosed embodiments accordingly comprise the features of construction, combination of elements and arrangement of parts that will be exemplified in the following detailed description.

BRIEF DESCRIPTION OF THE DRAWINGS

[0024] The presently disclosed embodiments will be further explained with reference to the attached drawings, wherein like structures are referred to by like numerals throughout the several views. The drawings shown are not necessarily to scale, with emphasis instead generally being placed upon illustrating the principles of the presently disclosed embodiments.

[0025] FIG. 1 is a perspective view of a suturing device of the presently disclosed embodiments.

[0026] FIGS. 2A and 2B are views of the suture head assembly of the suturing device of FIG. 1. FIG. 2A is an exploded perspective view of the suture head. FIG. 2B is a perspective assembly view of the suture head.

[0027] FIGS. 3A and 3B are segmented assembly views of the suture head assembly of FIG. 2.

[0028] FIGS. 4A and 4B are cutaway segmental views of the suture head assembly showing interaction points of a suturing needle with a portion of the drive mechanism. FIG. 4A shows the position of the suturing needle and drive mechanism in a "home" position prior to use or after a complete full cycle. FIG. 4B shows the position of the suturing needle and drive mechanism after one full actuation of the handle, where the suturing needle is in a "rotation" position.

[0029] FIGS. 5A and 5B are expanded views of the working end of the suture head assembly with a suturing needle in the home position. FIG. 5A shows the relationship between the pawl and anti-rotate spring when the suturing needle is in the home position. FIG. 5B shows a close-up view of the anti-rotate spring.

[0030] FIGS. 6A and 6B are expanded views of the working end of the suture head assembly during use of the device. FIG. 6A shows the position of the suturing needle and the pawl immediately after the user squeezes the handle. The user then

releases the handle and the pawl returns to the start position (FIG. 6B) while the suturing needle remains in the rotation position.

[0031] FIGS. 7A and 7B are expanded views of the pawl in contact with the C-brace while driving the suturing needle. FIG. 7A shows a close-up view of the pawl spring loaded with a spring. FIG. 7B shows a close-up view of the pawl, showing the heel and tip.

[0032] FIGS. 8 and 9 are side elevational views of a much larger scale of the internal portions of the drive mechanism located within the handle and elongated barrel. FIG. 8 shows the drive mechanism when the handle is in an open position and FIG. 9 shows the drive mechanism when the handle is in a closed position.

[0033] FIGS. 10-13 are top and bottom views of the cables that provide the connection between the drive mechanism located in the suture head assembly and the elongated barrel when the handle is in the open and closed positions. FIG. 10 shows a top view when the handle is in the open position. FIG. 11 shows a bottom view when the handle is in the open position. FIG. 12 shows a top view when the handle is in the closed position. FIG. 13 shows a bottom view when the handle is in the closed position.

[0034] FIG. 14 is a close-up view of the cartridge holder with a tab that locks into a mating groove on the cartridge holder assembly.

[0035] FIG. 15 is a suturing needle positioned in the track of the cartridge.

[0036] FIG. 16 shows the relation between the cartridge holder assembly, cartridge, latch and C-brace.

[0037] FIGS. 17A, 17B and 17C show the suture head assembly. FIG. 17A shows a side view of the suture head assembly. FIG. 17B is a close-up side view showing the relationship between the lever and latch during attachment and ejection of the needle and cartridge from the cartridge holder assembly. FIG. 17C shows a top view of the suture head assembly.

[0038] FIG. 18 is an expanded view of a curved suturing needle with notches on the surface of the needle.

[0039] FIGS. 19A and 19B are two embodiments of the curved suturing needle.

[0040] FIGS. 20-23 show different views of the suture head assembly attached to the elongated barrel via a rotation rod. The primary fixation point of the suture head assembly to the elongated barrel is at the axis of lateral rotation. FIG. 20 shows a side view of the suture head assembly. FIG. 21 shows a bottom view of the suture head assembly. FIG. 22 shows a bottom view of the suture head assembly articulated to the left. FIG. 23 shows a bottom view of the suture head assembly articulated to the right.

[0041] FIGS. 24 and 25 are perspective views of a suturing device. FIG. 24 shows a perspective view of the suturing device with the handles in the open position. FIG. 25 shows a perspective view of the suturing device with the handles in the closed position.

[0042] FIG. 26 is a segmented assembly view of the suture head assembly of FIGS. 24 and 25.

[0043] FIGS. 27A and 27B are cutaway segmental views of the suture head assembly of FIGS. 24 and 25 showing interaction points of a suturing needle with a portion of the drive mechanism. FIG. 27A shows the position of the suturing needle and drive mechanism in a "home" position prior to use or after a complete full cycle. FIG. 27B shows another view of the suturing needle and drive mechanism.

[0044] FIG. 28 is a close-up view of the needle holder assembly for the suture head assembly of FIGS. 24 and 25.

[0045] FIG. 29 is a close-up view of the distal end of the suture head assembly of FIGS. 24 and 25.

[0046] FIGS. 30 and 31 show the suture head assembly of FIGS. 24 and 25. FIG. 30 shows the suture head assembly with the latch in the open position. FIG. 31 shows the suture head assembly with the latch in the closed or locked position.

[0047] FIG. 32 is a view of a curved suturing needle with notches on the face of the suturing needle to be used with the suturing device of FIGS. 24 and 25.

[0048] FIG. 33 shows a view of the pawl in contact with the suturing needle for the suturing device of FIGS. 24 and 25.

[0049] FIGS. 34 and 35 show a close-up view of the suture head assembly of FIGS. 24 and 25 and the associated pulleys that move the drive mechanism. FIG. 34 shows a top view of the suture head assembly. FIG. 35 shows a side view of the suture head assembly.

[0050] FIGS. 36 and 37 are top views of the suture head assembly and cables that connect the drive mechanism located in the suture head assembly and the elongated barrel when the handle is in the open position for the suture device of FIGS. 24 and 25. FIG. 36 shows a top view of the front pulley and cable when the handle is in the open position. FIG. 37 shows a top view of the return pulley and cable when the handle is in the open position.

[0051] FIG. 38 shows a side elevational view of the suturing device of FIGS. 24 and 25 showing parts of the drive mechanism.

[0052] While the above-identified drawings set forth presently disclosed embodiments, other embodiments are also contemplated, as noted in the discussion. This disclosure presents illustrative embodiments by way of representation and not limitation. Numerous other modifications and embodiments can be devised by those skilled in the art which fall within the scope and spirit of the principles of the presently disclosed embodiments.

DETAILED DESCRIPTION

[0053] The suturing device of the presently disclosed embodiments is shown generally at 50 in FIG. 1. Referring to FIG. 1, the suturing device 50 can be used to produce a continuous or interrupted stitch or suture so as to enable closure of openings internal to a patient's body. The suturing device 50 can be utilized to suture any type of anatomical tissue in any type of anatomical cavity; and, accordingly, while the device 50 is described hereinafter for use with a cannula in endoscopic procedures, such as laparoscopy, the device 50 can be used in open surgery and with catheters and other small and large diameter tubular or hollow, cylindrical members providing access to small cavities, such as veins and arteries, as well as large cavities, such as the abdomen.

[0054] In an embodiment suturing device 50 includes an actuator mechanism shown generally at 52 which comprises an elongated barrel 54 and a handle 60 that extends from the undersides at a proximal end of the elongated barrel 54. A suture head assembly 56 is attached to the distal end of the elongated barrel 54. In an embodiment, the suture head assembly 56 is removably attached to the distal end of the elongated barrel 54. The length of the suture head assembly 56 can range from about 20 mm to about 100 mm. In an embodiment, the length of the suture head assembly 56 is about 50 mm. The length of the elongated barrel 54 can range from about 50 mm to about 400 mm. Those skilled in the art

will recognize that the elongated barrel 54 can be made shorter or longer depending on the intended use of the device 50. In an embodiment, the elongated barrel 54 is about 300 mm. In an embodiment, the elongated barrel 54 is about 350 mm. An articulation lever 66, just distal to the top of the handle 60 is pushed or pulled to cause the suture head assembly 56 to rotate. Moving the articulation lever 66 clockwise, moves the suture head assembly 56 to the right and moving the articulation lever 66 counterclockwise, moves the suture head assembly 56 to the left. The articulation lever 66 can also be moved to articulate the suture head assembly 56 up and down. The suture head assembly 56 is locked in place with a locking lever 64 located on an underside of the device 50, below the articulation lever 66. The suture head assembly 56 may be articulated, and the elongated barrel 54 may be any length appropriate for the intended clinical application of the device 50. The diameter of the device 50 can range from about 3 mm to about 20 mm. In an embodiment, the diameter of the device 50 is about 12 mm. In an embodiment, the diameter of the device 50 is about 3 mm. A flush port 62 is located on the side of the elongated barrel 54 in order to provide a port of entry for cleaning fluids or suction such that the device 50 can be cleaned prior to or after use.

[0055] The handle 60 is a grip that is squeezed in order to actuate the suturing device 50. The suturing device 50 is actuated by the actuator mechanism 52 coupled to a drive mechanism 70. The actuator mechanism 52 of the suturing device 50 may comprise a triggering mechanism that is known in the art, such as for example, the triggering mechanisms disclosed in U.S. Pat. Nos. 6,053,908 and 5,344,061, both of which are hereby incorporated by reference. Alternatively, the actuator mechanism can be either a manually operable button or switch, or a mechanically operable by an automated electrical or a fuel driven device, such as for example, an electrical, electromagnetic or pneumatic motor powered by electrical, electromagnetic, compressed air, compressed gas, hydraulic, vacuum or hydrocarbon fuels. Those skilled in the art will recognize that any actuator mechanism of any type known in the art can be within the spirit and scope of the presently disclosed embodiments.

[0056] FIG. 2A is an exploded perspective view of the suture head assembly 56 with a cartridge holder assembly 90 located at the distal end to which a cartridge 88 can be attached. In an embodiment, the suture head assembly 56 is fabricated as a single piece FIG. 2B is a perspective assembly view of the suture head assembly of the presently disclosed embodiments showing part of the drive mechanism 70, shown as a gear train/pulley system including pulleys 72, 74, 76 and 78. Located within the elongated barrel 54 are mechanical parts including drive shafts, belts, rods, cables, or hydraulic tubes which run from the elongated barrel 54 through the spherical portion 58 and then engages with the drive mechanism 70 in the suture head assembly 56. Connected at the proximal end of the suture head assembly 56 there is a spherical portion 58 that contains part of the drive mechanism 70 including two idler pulleys 80 and cables 84 and 86. The spherical portion 58 resides within the distal portion of the elongated barrel 54 and rotates in a frictionless fashion. In an embodiment, the drive mechanism 70 includes a gear train/pulley system ("locomotive-type" drive mechanism) and cables and rods that extend from the distal end of the suture head assembly 56 to the proximal end of the elongated barrel 54.

[0057] The suture head assembly 56 is that portion of the device 50 within which the mechanism for driving the curved needle 120 in a complete 360° circular arc, as well as the cartridge holder assembly 90 for attaching and releasing the cartridge 88 are situated. The suturing device 50 is unique in the fact that the orientation of the suture head assembly 56 is such that when the cartridge 88 is attached to the suture head assembly 56 the needle 120 is driven in a curved path about an axis approximately perpendicular to the longitudinal axis of the device 50. In this way, the needle 120 may be optimally visualized as the needle 120 is driven in a circular arc. Also, as shown in FIG. 2B, the needle 120 and cartridge 88 are in a plane parallel to the drive mechanism 70 and fit into the same space in the suture head assembly 56.

[0058] The improved visibility offered by the shape and configuration of the suture head assembly 56 enables precise device placement over the incision, and uniform advancement of the suturing device 50 after every stitch to provide a uniform and symmetric suture, thereby minimizing the risk of tearing tissue and bleeding due to a stitch being positioned too close to the edge of the incised tissue. In an embodiment, the entire device 50 or parts of the device 50, such as the suture head assembly 56, the elongated barrel 54, the handle 60, and the needle 120 and cartridge 88, are composed of a sterilizable medical grade plastic material, in which case, the entire device 50 or parts of the device 50 may be discarded and disposed after a single use. In an embodiment, the device 50 is composed of a sterilizable medical grade metallic material such as stainless steel to enable reuse subsequent to sterilization following a prior use. In an embodiment, the device 50 is composed of a sterilizable medical grade metallic material such as titanium to enable reuse subsequent to sterilization following a prior use. The use of titanium is ideal for certain procedures including Magnetic Resonance Imaging (MRI) and Computed Tomography (CT) because they are X-Ray radiolucent and do not interfere with MRI and CT scans.

[0059] FIGS. 3A and 3B provide detailed segmental views of the suture head assembly 56 showing the cartridge holder assembly 90, the disposable needle cartridge 88, a curved suturing needle 120, and parts of the drive mechanism 70 including a plurality of pulleys, 72, 74, 76, 78 and 80 involved in driving the needle driver 98 through a semicircular path. In an embodiment, the needle driver is a pawl 98. A shoulder screw 108 is used to keep a latch 110 locked in place over the disposable cartridge 88 and the suturing needle 120. Pulleys 72, 74, 76 and 78 are engaged with an actuator arm 102, which is attached to the pawl 98. The pawl 98 interfits with two notches 132 located on the needle 120 at 180° apart which drives the curved needle 120 in a completely circular arc. The suture head assembly 56 is configured so that the pawl 98 or other needle driver known in the art, does not intrude into or obstruct the area within the curve of the needle 120. The entire area within the circular arc of the needle 120 is unobstructed; there is no hub at the center of the circular arc so that the device 50 can encompass the maximum volume of tissue within the circular arc of the curved needle 120. In this way, the needle 120 may be rotated through a relatively large arc, allowing the needle 120 to obtain a sufficient "bite" into the tissue. Preferably, the needle 120 will have a radius of curvature of about 3 mm to about 40 mm. In an embodiment, the device 50 sutures within the limit of the diameter of the suture head assembly 56, which is advantageous to suturing through small cannulas during minimally invasive surgery. In an

embodiment, the diameter of the curved needle 120 does not exceed the diameter of the suture head assembly 56.

[0060] FIGS. 4A and 4B show detailed views of the drive mechanism 70 located in the suture head assembly 56 with respect to driving the needle 120 during use of the device 50 (the cartridge housing 88 has been removed to show the drive mechanism 70 in detail). The drive mechanism 70 includes a plurality of pulleys, 72, 74, 76 and 78, and the associated axel pins 82, involved in driving the pawl 98 through a semicircular path. The actuator arm 102 engages pulleys 72 and 76 and are pinned 75 to pulleys 72 and 76. As pulleys 76 and 78 rotate with the motion of the cables 86 and 84, respectively, that reside in the elongated barrel 54 (not shown), pulley 74 acts as an idler pulley, transferring the motion to the most distal pulley 72. Pulley 72 and pulley 76 rotate through identical arcs. The actuator arm 102 provides a connection to the pawl 98. The pawl 98 is located in the distal end of the actuator arm 102. The pawl 98 is attached to the actuator arm 102 by an integral shaft and collar 100 that fits loosely into the actuator arm 102 allowing smooth movement. As the handle 60 is closed and opened, the pawl 98 moves through the same arc as pulleys 72 and 76. The pawl 98 at the distal end of the actuator arm 102 is capable of engaging the notches 132 located along the radially inner edge of the needle 120. The actuator arm 102 is activated by the user upon squeezing of the handle 60, and is capable of sweeping back and forth in an arc spanning about 190° or more. FIG. 4A shows a detailed view of the drive mechanism 70 and the suturing needle 120 either prior to using the device 50 or after one complete full cycle of the device 50. FIG. 4B shows a detailed view of the drive mechanism 70 and the suturing needle 120 after one squeeze of the handle 60. As shown, the drive mechanism 70 has moved in a circular arc greater than about 180°, and about 190°, while the suturing needle 120 has moved in a circular arc of about 190° to drive through the tissue or vessel to be sutured.

[0061] The outer surface of the actuator arm 102 is shaped to accommodate a C-brace (not shown) that causes the pawl 98 to engage the needle 120 and thereby remain in contact. The advancing movement of the needle 120 during operation causes the notches 132 along the radially inner edge of the needle 120 to align with the pawl 98 in the actuator arm 102, thereby causing the pawl 98 to engage the notches 132 due to a positive pressure exerted by the C-brace (not shown), and to "lock" into the notches 132. The rotary advancing movement of the needle 120 is therefore controlled to occur sequentially through about 190° each time the needle is actuated.

[0062] FIG. 5A shows a close-up view of the distal end of the suture head assembly 56 with the cartridge 88 and the needle 120 in view as well as the relationship between the pawl 98 and the actuator arm 102 with respect to the needle 120. The needle 120 is enclosed within the cartridge 88, so the sharp pointed end 124 is not exposed. This needle position, as loaded, is referred to as the "home" position (FIG. 5A). In the home position, the needle 120 is fully contained within the cartridge housing 88 to eliminate needle-pricks during handling of the cartridge 88 or the loaded device. Squeezing the device handle 60 fully, two times, operates the device 50 through one full cycle. As shown in FIG. 6A, the first full actuation of the handle 60 drives the needle 120 through an about 190° arc. The pointed end of the needle 124 exits the protective enclosure of the cartridge 88, drives through the tissue to be sutured, and re-enters the protection of the cartridge 88 of the device 50. This position, after the first squeeze of the handle 60, is referred to as the "rotation" position. As

shown in FIG. 6B, the handle 60 is then released, and the needle 120 remains in the rotation position while the pawl 98 and the actuator arm 120 return to their start position. The handle 60 is then squeezed again driving the needle 120 through an about 190° arc and returning the needle 120 to the home position.

[0063] FIG. 5A shows the needle 120 in the home position, the pawl 98 is engaged in the notch 132 near the suture end of needle 126. An anti-rotate spring 136 is engaged in the notch 134 on the outer surface of the needle 120, not allowing the needle 120 to move backwards in the cartridge 88 of the device 50. A close-up view of the anti-rotate spring 136 is shown in FIG. 5B. In an embodiment, the needle 120 comprises at least one anti-rotate notch 134 and is engaged with at least one anti-rotate spring 136. As the pawl 98 drives the needle 120 through a first semi circular arc, the anti-rotate spring 136 slips out of the notch 134 and slides over the outer surface of the needle 120. As the pawl 98 reaches the end of a first drive stroke, the anti-rotate spring 136 snaps in behind the rear corner of the needle 120, near the suturing material or thread 146 (see FIG. 6A). As the pawl 98 returns to the start position, the anti-rotate spring 136 holds the needle 120 in place, preventing the needle 120 from moving with the pawl 98 back toward the start position. The pawl 98 returns to the start position and engages the notch 132 in the needle 120 near the pointed end 124 (see FIG. 6B). When the handle 60 is squeezed a second time, the needle 120 is driven back to the home position.

[0064] The width of the aperture 118 in the cartridge 88 is comparable to and corresponds with the width of the gap in the needle 120 so that when the needle 120 is in the home position (as shown in FIG. 5A) the needle 120 does not project materially into the aperture 118. Such an alignment causes the needle 120 to reside entirely within the cartridge 88, thereby preventing inadvertent contact of the sharp pointed end 124 with the user's fingers during handling of the disposable needle cartridge 88 for placement on the cartridge holder assembly 90 or disposal after use, and while operating the suturing device 50. Such protection of the needle 120 in the suturing device 50 prevents accidental "needle-pricks" from occurring, thereby substantially reducing the risk of infection caused by pathogenic bacteria or viruses that may contaminate the needle 120 during or after use prior to disposal. The needle 120 may be rotated in a curved track 92 of the cartridge 88 about the longitudinal axis of the suturing device 50 to advance the pointed needle end 124 so that the needle 120 first spans the aperture 118 and then returns to the home position. The suturing material or thread 146 is attached to the needle 120, and therefore follows the path of the needle 120. The suturing material or thread 146 may then be cut and secured by an appropriate method, such as for example, by tying, or additional stitches may be placed along the entire wound or incision by repeating the aforementioned process. Every stitch, whether a single, interrupted stitch, or one of a series of continuous, running stitches may be placed in like manner. The suturing device 50, therefore, may be used to insert either a single stitch, or to insert a suture comprising a plurality of continuous stitches as a replacement method for a more tedious and time-consuming manual suturing process. The terminal end of the suturing material or thread 146 may contain a knot or button to prevent the suturing material or thread 146 from pulling through the sutured tissue during placement of the first stitch. In an embodiment, the cartridge 88 comprises the suturing needle 120 attached to the terminal

end suturing material or thread 146, and an appropriate length of suturing material or thread 146 are all packaged in a sterilizable medical packaging material.

[0065] FIG. 7A shows a close-up view of the pawl 98 which rides in a track formed by the C-brace 106 and the suture head assembly 56. The pawl 98 is spring loaded with a spring 104. The spring 104 is engaged to the tip of the pawl 98b as shown in FIG. 7A. The spring 104 engages the pawl tip 98b into the notch 132 in the needle 120 during the driving stroke of the device 50 when the handle 60 is closed. The spring 104 also allows the tip of the pawl 98b to rotate out of notch 132 of the needle 120 during the return of the pawl 98 to the start position when the handle 60 is opened. The heel of the pawl 98a stays in contact with the C-brace 106 during the driving stroke of the device 50, preventing the pawl 98 from over-rotating and locking the needle 120. FIG. 7B shows a close-up view of the pawl 98 showing the pawl heel 98a and the pawl tip 98b. Referring now to FIGS. 8 and 9 in conjunction with FIG. 1, the user introduces the distal end portion of suturing device 50 into a body cavity, via a cannula assembly (not shown), and then laterally articulates the suture head assembly 56 using the articulation lever 66 located just distal to the top of the handle 60. The suture head assembly 56 is then positioned relative to the tissue/vessel to be sutured, and the user locks the suture head assembly 56 in place using the locking lever 64. The user then, through manipulation of suturing device 50, positions a plurality of separated tissue segments into the opening defined at the distal end portion of the suture head assembly 56 and within the aperture of the cartridge 118. The user, using only one hand, may manipulate the device 50 while actuating the handle 60 to close an incision with a continuous suture whose stitches may be individually tensioned precisely and uniformly along the length of the suture similar to suturing done by hand in the conventional way. The user may employ a single suture which would extend the entire length of the incision or multiple sutures.

[0066] The device 50 starts with the needle 120 in the home position and the handle 60 fully open (see FIG. 8). In an embodiment, the handle 60 is made up of a grip which rests in the user's palm and is squeezed in order to actuate the device 50. To drive the needle 120 through the tissue to be sutured, the user squeezes the handle 60 moving the needle 120 from the home position to the rotation position. The handle 60 contains linkages 144 to both the upper drive rod 142 and the lower drive rod 140. Squeezing the handle 60 (see FIG. 9) causes the two drive rods 140 and 142 to move in opposite directions. The upper drive rod 142, moves forward while the lower drive rod 140 moves backward. The drive rods are connected to the suture head assembly 56 with cables 84 and 86 and idler pulleys 80. The upper rod 142 is connected to pulley 78 with cable 84. The lower rod 140 is connected to pulley 76 with cable 86.

[0067] FIGS. 10 and 11 in conjunction with FIG. 8, show the connections and positions of cables 84 and 86 and the drive pulleys 72, 74, 76 and 78 when the handle 60 is in the open position. FIGS. 12 and 13 in conjunction with FIG. 9, show the connections and positions of cables 84 and 86 and the drive pulleys 72, 74, 76 and 78 when the handle 60 is in the closed position. The force to move needle 120 from the home position to the rotation position comes from the lower rod 140 pulling backward on the drive cable 86. The lower rod 140 extends nearly the full length of the elongated barrel 54, connecting to drive cable 86, at the proximal end of the elongated barrel 54. As shown in FIG. 11, cable 86 exits the

elongated barrel 54 and enters the suture head assembly 56, passing over an idler pulley 80 located in the spherical portion 58, then wrapping clockwise (as viewed from the bottom) around pulley 76 and is secured to pulley 76 located in the suture head assembly 56. The pulling action of cable 86 causes pulley 76 to rotate through an arc of approximately 190°. As lower rod 140 pulls backward, the upper rod 142 moves forward. The upper rod 142 also extends nearly the full length of the elongated barrel 54, connecting to drive cable 84, at the proximal end of the elongated barrel 54. As shown in FIG. 10, cable 84 also exits the elongated barrel 54 and enters suture head assembly 56, passing over a second idler pulley 80 located in the spherical portion 58, then wrapping (clockwise as viewed from the top) around pulley 78 and is secured to pulley 78 located in the suture head assembly 56. Pulley 78 is directly linked to pulley 76 through the actuator arm 102, and cables 84 and 86 are wrapped in opposing directions, so that as cable 86 unwinds from pulley 76, cable 84 winds onto pulley 78.

[0068] The needle 120 is held in a path of rotation by a combination of three components. The cartridge 88, the C-brace 106 and the cartridge holder assembly 90 interact to constrain the needle 120 to the path of rotation (see FIG. 5). The cartridge 88 is a semicircular shaped component that is held into the device 50 by a plurality of extensions 94 located on each end of the cartridge 88 (see FIGS. 14 and 15). In an embodiment, the plurality of extensions 94 takes the form of tabs. In an embodiment, the cartridge 88 is made from a sterilizable medical grade metallic material such as stainless steel. The cartridge 88 provides some of the support structure for keeping the needle 120 in a rotational path and therefore should be constructed from a material with structural integrity. Those skilled in the art will recognize that any high-strength medical grade material may be used to fabricate the cartridge 88, such as a high-strength plastic. In an embodiment, the plurality of extensions are tabs extending from the cartridge housing 88. The plurality of extensions 94 lock into mating grooves 96 located along on the distal edge of the cartridge holder assembly 90 that are located diametrically opposite to one another, and are capable of engaging the plurality of extensions 94 correspondingly located in the needle cartridge housing 88 as shown in FIG. 16.

[0069] The proximal end of cartridge 88 is held in place by a cartridge holder assembly 90, as shown in FIG. 17A. The cartridge holder assembly 90 also includes a latch 110, a lever 112, associated pins 114 and 116, a shoulder screw 108, an anti-rotate spring 136 and at least one groove 96 that can engage with the plurality of extensions 94 located on the cartridge 88. It is the interaction of all of the elements of the cartridge holder assembly 90 that hold and lock the cartridge 88 in place. The latch 110 slides back to release the cartridge 88 and forward to lock the cartridge 88 in place. The latch 110 also has a built into ejector feature, as shown in FIG. 17B. A lever 112 is located distal and below the needle 120 and the cartridge 88. The lever 112 pivots on a pin 114. A second pin 116 located above the pivot pin 114, engages with a slot in the latch 110. To release the needle 120 and the cartridge 88, the latch 110 is pulled back and the lever 112 is rotated up and back, causing pin 116 to move back with the latch 110 and to rotate about pin 114 thus pushing the needle 120 and the cartridge 88 from the cartridge holder assembly 90. The needle 120 and the cartridge 88 are then removed from the device 50 by a slight proximal motion to disengage the plurality of extensions 94 from their mating grooves 96 in the

cartridge holder assembly 90. FIG. 17C shows the needle 120 as it is driven through a first semi circular arc (the handle 60 has partially completed a first full squeeze). As the pawl 98 drives the needle 120 through a first semi circular arc, the anti-rotate spring 136 slips out of the notch 134 and slides over the outer surface of the needle 120.

[0070] Loading of the needle 120 and the cartridge 88 is accomplished by engaging the plurality of extensions 94 into both grooves 96 on the cartridge holder assembly 90 and then pressing the proximal ends down against the sloped distal surface of the latch 110. The latch 110 is spring loaded at the proximal end, thus can slide back as the needle 120 and the cartridge 88 are pressed into place and then snap closed to the locked position, retaining the needle 120 and the cartridge 88. The lever 112 is down and out of the way of the operation of the needle 120 and the cartridge 88.

[0071] FIG. 18 shows a close-up view of the needle 120. The two notches 132 are located about 180° apart on the inner surface and assist in driving the needle 120. The pawl 98 engages the notches 132 when driving the needle 120 through the circular motion. A third notch 134 is located on the outer surface of the needle 120. The notch 134 assists in preventing rotation of the needle 120 and provides an anti-rotation feature. In an embodiment (see FIGS. 19A and 19B), the needle 120 is formed as a circular split ring with a gap 122, a sharp, pointed end 124, and a blunt end 126. The needle 120 further comprises an opening 130 to accommodate the leading end of the suturing material or thread 146. In an embodiment, the opening 130 is the form of an eye through which the leading end of the suturing material or thread 146 may be passed through for attachment to the needle 120. In the illustrated needle 120 (FIG. 19A), the opening 130 is located adjacent to the blunt end 126. The opening 130 however, can be positioned anywhere along the arc or the needle 120 between the apex 128 and the blunt end 126. In an embodiment (FIG. 19B), the needle 120 comprises an opening 130 in the form of a cylindrical bore aligned axially with respect to the needle 120, located at the blunt end 126 (FIG. 19B). The leading end of the suturing material or thread 146 is inserted into the opening 130 and restrained by mechanically crimping. To enable the needle 120 to penetrate tissue to a required depth, the arc length of the needle 120 is preferably about 240° to about 300°. The needle 120 comprises two symmetric notches 132 along the radially inner edge ("inner notches") that are positioned proximally to the sharp, pointed end 124 and the blunt end 126 of the needle 120. The notches 132 are located directly opposite to each other, each having a perpendicular (about 90°) segment and an angular segment that makes an angle of about 60° with the perpendicular segment. The inner notches 132 are engaged by the needle driver 98 of the drive mechanism 70 and enable the needle 120 to undergo a rotary movement upon actuation of the drive mechanism 70, thereby causing the needle 120 to penetrate into and advance through tissue. A similar triangular notch 134 is located on the radially outer edge ("outer notch") of the needle 120 proximally to the inner notch 132 closer to the sharp, pointed end 124. The outer notch 134 engages with the anti-rotate spring 136 located on the cartridge holder assembly 90, whereby rotation of the needle 120 in a direction opposite to the advancing direction or "needle backing-up" is prevented. The positive engagement of the needle outer notch 134 during operation of the suturing device precludes needle 120 from straying out of sequence during the suturing process.

[0072] The suture head assembly 56 of the device 50 can be laterally articulated to the left of center and also to the right of center. In an embodiment, the suture head assembly 56 can be laterally articulated through an arc of about 22.5° to the left of center and also to the right of center, for a total of about 45° or more. In addition, the suture head assembly can be articulated up and down. In an embodiment, the suture head assembly 56 can be articulated up and down. The ability of the suture head assembly 56 to be articulated to the left and right of center, as well as up and down, permits the user to position the suture head assembly 56 for many different types of suturing applications. The articulation lever 66, just distal of the top of the handle 60 is pushed or pulled to cause the suture head assembly 56 to rotate. Viewed from above, moving the articulation lever 66 clockwise, moves suture head assembly 56 to the right and moving the articulation lever 66 counterclockwise, moves suture head assembly 56 to the left. The suture head assembly 56 is locked in place with the locking lever 64 located on the bottom of the device 50, below the articulation lever 66. Movement is accomplished using the solid articulation rod 68 to link the articulation lever 66 to the suture head assembly 56. The articulation rod 68 is pinned to the articulation lever 66 and to one side of the most proximal section of the suture head assembly 56 so that the articulation rod 68 pushes or pulls the suture head assembly 56 through a full range of motion (see FIGS. 20-23).

[0073] FIGS. 20-23 show the articulation rod 68 in the elongated barrel 54 and the connection to the suture head assembly 56. The suture head assembly 56 is shown moving from left articulation, to straight to right articulation (some components are not shown to allow clear viewing of the linkage). FIG. 20 shows a side view of the suture head assembly 56. FIG. 21 shows a bottom view of the suture head assembly 56 with no articulation. FIG. 22 shows a bottom view of the suture head assembly 56 articulated to the left. FIG. 23 shows a bottom view of the suture head assembly 56 articulated to the right. FIGS. 20-23 show a number of items. The articulation rod 68 runs down the center of the elongated barrel 54 and is attached to one side of the spherical portion 58. The function of the articulation rod 68 is to push and pull the suture head assembly 56 through an articulation. The two idler pulleys 80, which drive cables 84 and 86 are located in the spherical portion 58. Looking at FIG. 20, the two idler pulleys 80 seem to be one on top of the other, instead however, they are located in plane with either pulley 76 and lower rod 140 or pulley 78 and upper rod 142.

[0074] In an embodiment, the entire suturing device 50 can be designed as a single unit which may be either reusable or disposed after a single use. In an embodiment, the entire suturing device 50 can be designed from a number of units which, each unit may be either reusable or disposed after a single use.

[0075] The suturing device 50 is configured to provide a "pistol like" grip for the user that includes an elongated barrel 54 and a handle 60 that extends from the proximal end of the elongated barrel 54. The elongated barrel 54 has either a linear or non-linear configuration, including but not limited to, straight, curved and angled configurations. A suture head assembly 56 is removably attached to the distal end of the elongated barrel 54. The suture head assembly 56 contains a portion of the drive mechanism 70 of the device 50. The working end of the suture head assembly 56 has a cartridge holder assembly 90 to which a disposable cartridge 88 that is capable of accommodating a suturing needle 120 may reside.

[0076] The disposable cartridge 88 has a generally cylindrical housing with an opening or aperture 118 in the sidewall of the housing at the distal or working end thereof. An arcuate suturing needle 120 having a sharp, pointed end 124 is slidably mounted in a circular track 92 of the cartridge 88. A blunt end of the needle 126 is connected to a suturing material or thread 146. The radius of the arc defining the arcuate suturing needle 120 is approximately equal to the circumference to the cartridge housing 88 at the aperture 118 therein. The needle 120 normally resides in a "home" position in the track 92 such that the gap in the arcuate suturing needle 122 is in alignment with the aperture 118 in the cartridge 88. The sharp, pointed end of the needle 124 is situated on one side and entirely within the confines of the housing aperture 118; the pointed end of the needle 124 is, therefore, shielded by the cartridge housing 88. The blunt end of the suturing needle 126 that is attached to the suturing material or thread 146 is located at the opposite side of the aperture 118. The sharp, pointed end of the needle 124 is, therefore, wholly contained within the cartridge 88 and does not protrude beyond the housing of the cartridge 88. Thus, the sharp pointed end of the needle 124 is not exposed to the user.

[0077] In accordance with the presently disclosed embodiments, the needle 120 may be releasably engaged by a needle driver 98 that is rotatably mounted within the suture head assembly 56 so that the needle 120 can be rotated from the home position by about 360° about the central vertical axis of the cartridge 88. Such a rotary action of the needle 120 causes the sharp point 124 to advance across the cartridge housing 88 so as to span the aperture 118. Thus, when the device 50 is positioned such that the incised tissue segments to be sutured are situated at the housing aperture 118, the needle 120 penetrates the tissue segments and spans the incision between them. A continued rotary movement of the needle 120 causes the needle 120 to return to the home position, and thereby causes the suturing material or thread 146 attached to the needle 120 to be pulled into and through the tissue in an inward direction on one side of the tissue incision, and upwards and out through the tissue on the opposite side of the incision. Thus, the suture material or thread 146 follows the curved path of the needle 120 to bind the tissues together with a stitch of material or thread 146 across the incision in a manner similar to manual suturing, wherein the needle 120 is "pushed" from the blunt end 126 and then "pulled" from the pointed end 124 by the pawl 98. Preferably, an anchoring mechanism is provided at the trailing terminal end of the suturing material or thread 146 to prevent the material 146 from being pulled completely through and out of the tissue segments. For example, the anchoring mechanism can be a pre-tied or a welded loop, a knot wherein the suture material or thread 146 is simply tied, or a double-stranded, looped suture is that attached to the suturing needle 120. The rotary movement of the needle 120 within the needle cartridge 88 is accomplished by a pawl 98 that may be operated by the user by holding the suturing device 50 with one hand in a pistol-like grip around the handle 60, and using at least one finger of that hand to activate.

[0078] The suturing device 50 of the presently disclosed embodiments can be used for a laparoscopic procedure, including but not limited to laparoscopic colostomy, colectomy, adrenalectomy, splenectomy, repair of paraesophageal hernia, inguinal hernia repair, ventral hernia repair, Nissen fundoplication, liver lobectomy, gastrectomy, small bowel resection, treatment of small bowel obstruction, distal pan-

createctomy, nephrectomy and gastric bypass. Those skilled in the art will recognize that the presently disclosed embodiments can be used in other laparoscopic procedures.

[0079] In using the device 50 of the presently disclosed embodiments, the abdomen is insufflated with gas to create a working space for the user. Any gas known to those skilled in the art including, but not limited to, nitrogen or carbon dioxide, can be used. Access portals are established using trocars in locations to suit the particular surgical procedure. A variety of surgical instruments may then be inserted into the body through these access ports/cannulas. The user then introduces the distal end portion of suturing device 50 into a cannula, and then laterally articulates the suture head assembly 56 using the articulation lever 66 located just distal to the top of the handle 60. The suture head assembly 56 is then positioned relative to the tissue/vessel to be sutured together, and the user locks the suture head assembly 56 in place using the locking lever 64. The user then, through manipulation of suturing device 50, positions a plurality of separated tissue segments into the opening defined at the distal end portion of the suture head assembly 56 and within the aperture 118 of the cartridge 88. The user, using only one hand, may manipulate the device 50 while actuating the handle 60 to close an incision with a continuous suture whose stitches may be individually tensioned precisely and uniformly along the length of the suture similar to suturing done by hand in the conventional way. The user may employ a single suture which would extend the entire length of the incision or multiple sutures. Thus, by placement of the device 50 with the needle cartridge aperture 118 spanning the incised tissue segments and actuating the handle 60, the suturing device 50 enables the user to lay down a running stitch or interrupted stitch to close the tissue incision in a time efficient manner. Those skilled in the art will recognize that any conventional procedure for conducting laparoscopic surgery can be used with the device 50.

[0080] The needle cartridge 88 is disposably mounted on a cartridge holder assembly 90 at the distal end of the suture head assembly 56. The minimized structural design of the suture head assembly 56 enables the user to have a clear, unobstructed view of the suturing needle 120 during advancement through the tissue segments during the course of a suturing operation, thereby enabling precise placement of the suturing device 50 to provide uniform sutures and precluding the risk of tearing tissue by placement too close to the edge of the incision. The suturing device 50 is then advanced a short distance along the incision and the aforementioned operation is repeated to produce another stitch comprising the suturing material or thread 146.

[0081] The user may continue to manipulate the suturing device 50, alternately advancing and actuating rotation of the needle 120 about an axis that is generally parallel to the direction of advancement to create a continuous suture which may extend through the entire length of the incision or a series of interrupted stitches. After each individual stitch is laid down, the stitch is tightened by exerting a pull on the suturing material or thread 146 so that the resultant suture is tensioned uniformly along the length of the incised tissue segments. Therefore, a tight closure of the segments is accomplished and bleeding and tearing of tissue are minimized. Once the appropriate amount of suture material or thread 146 has been placed, the user can use a needle grasper to tighten and knot the formed stitches.

[0082] The presently disclosed embodiments provide a method for suturing tissue during minimally invasive surgery

including engaging a cartridge 88 to a suture head assembly 56 at a distal end of a suturing device 50, the cartridge 88 having a protective housing and a suturing needle 120 with a pointed end 124 and a blunt end 126; introducing the distal end of the suturing device 50 into a body cavity; positioning an opening 118 in the cartridge 88 to span a plurality of separated tissue segments; activating an actuator 52 coupled to a drive mechanism 70 that engages the suturing needle 120 to cause rotational movement of the suturing needle 120 about an axis approximately perpendicular to a longitudinal axis of the suturing device 50 and advance the suturing needle 120 through the plurality of separated tissue segments; and pulling a suturing material 146 attached to the suturing needle 120 through the plurality of separated tissue segments forming a stitch.

[0083] The presently disclosed embodiments provide a method for suturing tissue during minimally invasive surgery including (a) engaging a cartridge 88 to a suture head assembly 56 at a distal end of a suturing device 50, the cartridge 88 having a protective housing and a suturing needle 120 with a pointed end 124 and a blunt end 126; (b) introducing the distal end of the suturing device 50 into a body cavity; (c) positioning an opening 118 in the cartridge 88 to span a plurality of separated tissue segments; (d) activating an actuator 52 coupled to a drive mechanism 70 that engages the suturing needle 120 to cause rotational movement of the suturing needle 120 about an axis approximately perpendicular to a longitudinal axis of the suturing device 50 and advance the suturing needle 120 through the plurality of separated tissue segments; (e) pulling a suturing material 146 attached to the suturing needle 120 through the plurality of separated tissue segments forming a stitch and repeating steps (c) through (e) to cause a plurality of stitches to be placed through the separated tissue segments.

[0084] The presently disclosed embodiments provide a method for suturing tissue during minimally invasive surgery including inserting a distal end of a suturing device 50 having a suturing needle 120 with a pointed end 124 into a body; positioning the suturing needle 120 to span a plurality of separated tissue segments; activating an actuator 52 a first time causing the pointed end 124 of the suturing needle 120 to extend beyond a protective housing of a cartridge 88 to engage the plurality of separated tissue segments; activating the actuator 52 a second time to cause the suturing needle 120 to complete a revolution and pull a suture 146 extending from the suturing needle 120 through the plurality of separated tissue segments to form a stitch.

[0085] The suturing device 50 may be configured in different ways with respect to length and angle of the suture head assembly 56. The size of the needle 120, the needle cartridge 88, the cartridge aperture 118 and the aperture position may also be varied for use in open surgery to perform procedures such as closing of the fascia, skin closure, soft tissue attachment, anastomosis, fixation of mesh, grafts and other artificial materials.

[0086] FIGS. 24 and 25 show an alternative embodiment of a suturing device shown generally at 150. Referring to FIGS. 24 and 25, the suturing device 150 can be used to produce a continuous or interrupted stitch or suture so as to enable closure of openings internal to a patient's body. The suturing device 150 can be utilized to suture any type of anatomical tissue in any type of anatomical cavity; and, accordingly, while the device 150 is described hereinafter for use with a cannula in endoscopic procedures, such as laparoscopy, the

device **150** can be used in open surgery and with catheters and other small and large diameter tubular or hollow, cylindrical members providing access to small cavities, such as veins and arteries, as well as large cavities, such as the abdomen.

[0087] In an embodiment, the suturing device **150** includes an actuator mechanism shown generally at **152** which comprises an elongated barrel **154** and a handle **160** that extends from the undersides at a proximal end of the elongated barrel **154**. Located within the elongated barrel **154** are mechanical parts including cables which run from the elongated barrel **154** through a spherical portion **158** and then engages with the drive mechanism in a suture head assembly **156**. The spherical portion **158** resides within the distal portion of the elongated barrel **154** and rotates with low friction. In an embodiment, a drive mechanism **170** includes a pulley system and cables that extend from the distal end of the suture head assembly **156** to the proximal end of the elongated barrel **154**.

[0088] The suture head assembly **156** houses the mechanism for driving a curved needle **220** in a complete 360° circular arc. The orientation of the suture head assembly **156** is such that when the needle **220** is attached to the suture head assembly **156** the needle **220** is driven in a curved path about an axis approximately perpendicular to the longitudinal axis of the device **150**. In this way, the needle **220** may be optimally visualized as the needle **220** is driven in a circular arc. Also, as shown in FIGS. **24** and **25**, the needle **220** is in a plane parallel to the drive mechanism and fits into the same space in the suture head assembly **156**.

[0089] The improved visibility offered by the shape and configuration of the suture head assembly **156** enables precise device placement over the incision, and uniform advancement of the suturing device **150** after every stitch to provide a uniform and symmetric suture, thereby minimizing the risk of tearing tissue and bleeding due to a stitch being positioned too close to the edge of the incised tissue. In an embodiment, the entire device **150** or parts of the device **150**, such as the suture head assembly **156**, the elongated barrel **154**, the handle **160**, and the needle **220**, are composed of a sterilizable medical grade plastic material, in which case, the entire device **150** or parts of the device **150** may be discarded and disposed after a single use. In an embodiment, the device **150** is composed of a sterilizable medical grade metallic material such as stainless steel to enable reuse subsequent to sterilization following a prior use. In an embodiment, the device **150** is composed of a sterilizable medical grade metallic material such as titanium to enable reuse subsequent to sterilization following a prior use. The use of titanium is beneficial for certain procedures including Magnetic Resonance Imaging (MRI) and Computed Tomography (CT) because they are X-Ray radiolucent and do not interfere with MRI and CT scans.

[0090] FIG. **24** shows the handle **160** in an open position. FIG. **25** shows the handle **160** in the closed position. The suture head assembly **156** is attached to the distal end of the elongated barrel **154**. In an embodiment, the suture head assembly **156** is removably attached to the distal end of the elongated barrel **154**. The length of the suture head assembly **156** can range from about 10 mm to about 100 mm. In an embodiment, the length of the suture head assembly **156** is about 40 mm. The length of the elongated barrel **154** can range from about 50 mm to about 400 mm. Those skilled in the art will recognize that the elongated barrel **154** can be made shorter or longer depending on the intended use of the device **150**. In an embodiment, the elongated barrel **154** is about 300 mm. In an embodiment, the elongated barrel **154** is

about 350 mm. An articulation lever **166**, just distal to the top of the handle **160** is pushed or pulled to cause the suture head assembly **156** to rotate. Moving the articulation lever **166** clockwise, moves the suture head assembly **156** to the right and moving the articulation lever **166** counterclockwise, moves the suture head assembly **156** to the left. The articulation lever **166** can also be moved to articulate the suture head assembly **156** up and down. The suture head assembly **156** is locked in place with a locking lever **164** located on an underside of the device **150**, below the articulation lever **166**. The suture head assembly **156** may be articulated, and the elongated barrel **154** may be any length appropriate for the intended clinical application of the device **150**. The diameter of the device **150** can range from about 3 mm to about 20 mm. In an embodiment, the diameter of the device **150** is about 12 mm. In an embodiment, the diameter of the device **150** is about 3 mm.

[0091] The handle **160** may be a grip that is squeezed in order to actuate the suturing device **150**. The suturing device **150** is actuated by the actuator mechanism **152** coupled to a drive mechanism **170**. The actuator mechanism **152** of the suturing device **150** may comprise a triggering mechanism that is known in the art, such as for example, the triggering mechanisms disclosed in U.S. Pat. No. 6,053,908 and U.S. Pat. No. 5,344,061, both of which are hereby incorporated by reference. Alternatively, the actuator mechanism **152** can be either a manually operable button or switch, or mechanically operable by an automated electrical or a fuel driven device, such as for example, an electrical, electromagnetic or pneumatic motor powered by electrical, electromagnetic, compressed air, compressed gas, hydraulic, vacuum or hydrocarbon fuels. Those skilled in the art will recognize that any actuator mechanism of any type known in the art can be within the spirit and scope of the presently disclosed embodiments.

[0092] FIG. **26** provides an assembly view of the suture head assembly **156**. The suture head assembly **156** is fabricated from multiple pieces including a holder assembly **190**, a needle holder assembly **188**, a latch **210**, and parts of the drive mechanism **170** including a plurality of pulleys, **172**, **174** and **176** and two idler pulleys **180** involved in driving a needle driver **198** through a semicircular path. Pulleys **172** and **174** consist of a set of four pulleys, or two sets of pulleys, labeled **178**. In an embodiment, the needle driver is a pawl **198**. A shoulder screw **208** and a plurality of needle assembly extensions **194** are used to keep the latch **210** locked in place over the needle holder assembly **188** and the suturing needle **220**. The needle holder assembly **188** includes a curved track **192** where the needle **220** rides. Pulleys **172**, **174** and **176** are engaged with an actuator arm **202**, which is attached to the pawl **198**. The pawl **198** interfits with two notches **232** located on the face of the needle **220** at about 180° apart which drives the curved needle **220** in a circular arc. The suture head assembly **156** is configured so that the pawl **198** or other needle driver known in the art, does not intrude into or obstruct the area within the curve of the needle **220**. The area within the circular arc of the needle **220** is unobstructed; there is not a hub at the center of the circular arc so that the device **150** can encompass the maximum volume of tissue within the circular arc of the curved needle **220**. In this way, the needle **220** may be rotated through a relatively large arc, allowing the needle **220** to obtain a sufficient "bite" into the tissue. Preferably, the needle **220** will have a radius of curvature of about 3 mm to about 40 mm. In an embodiment, the device **150**

sutures within the limit of the diameter of the suture head assembly 156, which is advantageous to suturing through small cannulas during minimally invasive surgery. In an embodiment, the diameter of the curved needle 220 does not exceed the diameter of the suture head assembly 156.

[0093] FIGS. 27A and 27B show detailed views of the drive mechanism 170 located in the suture head assembly 156 with respect to driving the needle 220 during use of the device 150 (the needle holder assembly 188 and the holder assembly 190 have been removed to show the drive mechanism 170 in detail). The drive mechanism 170 includes the actuator arm 202 that engages pulleys 172, 174, and 176 and the pawl 198 that drives the needle 220 through a curved path. The pawl 198 is located in the distal end of the actuator arm 202 and is capable of engaging the notches 232 located along the face of the needle 220. A flat spring 200 keeps the pawl 198 engaged into the notches 232 of the needle 220. When the needle 220 is pushed around, the pawl 198 will be pushed back up against the flat spring 200 and allow the needle 220 to cycle. As the handle 160 is closed and opened, the pawl 198 moves through the same arc as the pulleys. The actuator arm 202 is activated by the user upon squeezing of the handle 160, and is capable of sweeping back and forth in an arc spanning about 190° or more.

[0094] FIG. 28 shows a close-up view of the needle holder assembly 188 showing the curved track 192 where the needle 220 resides as well as the needle holder assembly extensions 194 that help keep the latch 210 in place. The suturing needle 220 follows a curved path along the track 192 during rotation of the suturing needle 220. The curved track 192 for the needle 220 may be machined into the needle assembly 188 and provides a captive curved track 192 so that the needle 220 can be driven around with precision. The curved track 192 includes an inside slot and a larger slot surrounding the inside slot. The larger outside slot provides clearance for the pawl 198, so that the pawl 198 can maneuver around without hitting anything, and the smaller inside slot provides clearance for a pawl tip 199, which goes through the smaller inside slot and then into the needle 220 so that the pawl tip 199 can drive the needle 220.

[0095] FIG. 29 shows a close-up view of the suture head assembly 156 with the needle holder assembly 188, the holder assembly 190, the latch 210 and the needle 220 in view as well as the relationship between the pawl 198 and the actuator arm 202 with respect to the needle 220. The needle 220 is enclosed within the needle holder assembly 188, so the sharp pointed end 224 of the needle 220 is not exposed. This needle 220 position, as loaded, is referred to as the “home” position. In the home position, the needle 220 is fully contained within the needle holder assembly 188 to eliminate needle-pricks during handling of the suture head assembly 156. The needle assembly extensions 194 form a “tongue-in-groove” connection with the latch 210, which keeps the forces from the needle 220 from opening the thin members of the latch 210. The needle assembly extensions 194 cause an entrapment at a distal end of the suturing device, thus locking the latch 210 in place. Squeezing the device handle 160 fully operates the device 150 through one full cycle. The first full actuation of the handle 160 drives the needle 220 through an about 190° arc. The pointed end 224 of the needle 220 exits the protective enclosure of the needle holder assembly 188, drives through the tissue to be sutured, and re-enters the protection of the needle holder assembly 188 of the device 150. This position, after the first squeeze of the handle 160, is referred to as the

“rotation” position. The handle 160 is then released, and the needle 220 remains in the rotation position while the pawl 198 and the actuator arm 220 return to their start position. The handle 160 is then squeezed again driving the needle 220 through an about 190° arc and returning the needle 220 to the home position. A flat pawl spring 200 keeps the pawl 198 engaged into the pawl notches 232 on the needle 220. When the needle 220 is pushed around the pawl 198 will be pushed back up against the flat pawl spring 200 and allow the needle 220 to cycle.

[0096] FIGS. 30 and 31 show top views of the suture head assembly 156. Needle holder assembly 188 forms a connection with the latch 210. The latch 210 forms a top cover over the suturing needle 220 which is in the curved track 192 of the needle holder assembly 188. FIG. 30 shows the latch 210 in the open position, which is for needle 220 removal and insertion into the needle holder assembly 188. To insert and/or remove the needle 220 a user may turn the needle 220 180° in its curved track 192 from the as-drawn position. A user may grab the needle 220 by hand or with a surgical tool to either install the needle 220 or remove the needle 220. By grabbing the needle 220, lifting the needle 220 out, the needle 220 is removed. By grabbing the needle 220 the needle can be inserted when the latch 210 in the open position. FIG. 31 shows the latch 210 in the locked position, also known as the forward position.

[0097] FIG. 32 shows the suturing needle 220. The two notches 232 are located about 180° apart on the face of the needle 220 and assist in driving the needle 220. The pawl 198 engages the notches 232 when driving the needle 220 through the circular motion. A third notch 234 is located on the outer surface of the needle 220. The notch 234 provides an anti-rotation feature by preventing rotation of the needle 220. The needle 220 is formed as a circular split ring with a gap 222, a sharp, pointed end 224, and a blunt end 226. The needle 220 further comprises an opening 230 to accommodate the leading end of the suturing material or thread 246. In an embodiment, the opening 230 is the form of an eye through which the leading end of the suturing material or thread 246 may be passed through for attachment to the needle 220. In the illustrated needle 220, the needle 220 comprises an opening 230 in the form of a cylindrical bore aligned axially with respect to the needle 220, located at the blunt end 226. The opening 230, can be positioned anywhere along the arc or the needle 220 between the apex 228 and the blunt end 226. The leading end of the suturing material or thread 246 is inserted into the opening 230 and restrained by mechanically crimping or other connection methods known in the art. To enable the needle 220 to penetrate tissue to a required depth, the arc length of the needle 220 is preferably about 240° to about 300°. The needle 220 comprises two symmetric notches 232 along the face (“drive notches”). The notches 232 are located directly opposite to each other. A similar notch 234 is located on the radially outer edge (“outer notch”) of the needle 220 proximally to the inner notch 232 closer to the sharp, pointed end 224. The outer notch 234 engages with an anti-rotate spring, whereby rotation of the needle 220 in a direction opposite to the advancing direction or “needle backing-up” is prevented. The positive engagement of the needle outer notch 234 during operation of the suturing device precludes the needle 220 from straying out of sequence during the suturing process.

[0098] FIG. 33 shows a close-up view of the pawl tip 199 engaging the drive notches 232 of the needle 220. The drive

notches 232 are engaged by the pawl tip 199 of the drive mechanism 170 and enable the needle 220 to undergo a rotary movement upon actuation of the drive mechanism 170, thereby causing the needle 220 to penetrate into and advance through tissue.

[0099] FIGS. 34 and 35 show parts of the drive mechanism 170 including return pulleys 172 and 174. Pulleys 172 and 174 are connected to each other using wires 175. As can be seen in FIG. 27A and FIG. 27B; pulleys 172 and 174 are made up of four pulleys 178 that are connected together by laser welding or other methods known in the art. The four pulleys 178 produce an over-rotation, about a 190°-rotation. The over-rotation leads to the wire 175 design where there is a wire 175 on each set of pulleys 178. As shown in FIG. 34 and FIG. 35, there are two wires 175 with four pulleys 178, resulting in the four pulleys 178 being in synch with one another, even under load. The four pulleys 178 are rotationally in synch, i.e., one pulley 178 will follow the other pulley 178, because the wires 175 are configured to be pulling against one another. The wire 175 may be attached to the pulleys 178 via a hole that the wires 175 are soldered into. FIG. 35 shows a side view of the suture head assembly 156 which shows the two wires 175 connecting the four pulleys 178 together for synchronized rotation.

[0100] FIGS. 36 and 37 in conjunction with FIG. 38, show the connections and positions of cables 184 and 186 to the drive pulley 176 and to the return pulleys 172 and 174, respectively, and to the when the handle 160 is in the open position. The cables 184 and 186 may be made from stainless steel. Connected at the proximal end of the suture head assembly 156 there is the spherical portion 158 that contains part of the drive mechanism 170 including two idler pulleys 180 and cables 184 and 186. FIG. 36 shows a top view of the suture head assembly 156 with the cable 184 running through two idler pulleys 180 and wrapped around drive pulley 176. FIG. 37 shows a top view of the suture head assembly 156 with the cable 186 running through two idler pulleys 180 and wrapped around return pulley 174. The cable 186 runs from return pulley 174 through the elongated barrel 154 and to the very proximal end of the handle 160. The force to move the needle 220 from the home position (shown in FIGS. 36 and 37) to a rotation position comes from a return spring 240 that is connected to the cable 184, resulting in a pre-load (shown in FIG. 38). When the trigger of the handle 160 is squeezed closed, the handle 160 moves to the closed position and the drive pulley 176 turns counterclockwise, driving the needle 220. At the same time, the cable 186 drives the return pulley 174 counterclockwise and cycles the actuator arm 202 to drive the needle 220 forward through the tissue. The needle 220 is driven through a circular motion, through a cycle, and the cable 184 is compressing the return spring 240 on the other end. When the handle 160 closes more, the actuator arm 202 drives the needle. When the trigger of the handle 160 is released, the front pulley 178, which is now fully charged with the return spring 240, will return the needle 220 to the home position. Relaxing the trigger of handle 160 takes no power.

[0101] FIG. 38 shows a side elevational view of the suturing device 150. The handle 160 includes a number of internal parts. A cable connector 182 has a hole and a shoulder. The shoulder rides against the end of the return spring 240, and the hole provides an opening for the cable 184. The return spring 240 is compressed and the cable 184 is soldered or locked to the connector 182, so that the cable 184 provides a preload

onto the return spring 240. The cable 184 runs from the connector 182 through the return spring 240 over pulley 244, through the elongated barrel 154, through the spherical portion 158, between the idler pulleys 180 and fixed to the drive pulley 176. The cable 186 is connected at the very proximal end of the handle 160 and lies under pulley 245, over pulley 242, through the elongated barrel 154, through the spherical portion 158, between the idler pulleys 180 and fixed to the return pulley 174.

[0102] When the handle 160 is translated from the open position to the closed position the needle 220 is driven through the tissue. A user has a tactile feel as the needle 220 moves. If the needle 220 runs across something that is impenetrable, the handle 160 will stop moving and the user could feel this in their hand holding the handle. When the handle 160 is in a closed position, the return spring 240 takes on a charge, the return spring 240 has shortened in length. When the handle 160 is released, the return spring 240 pulls the cable 184 and brings the needle 220 back to the home position and also brings the handle 160 back to the open position. The return spring 240 provides a load on the cable 184. A loop is formed throughout the suturing device 150 that includes the cables 184 and 186 and the pulleys 172, 174 and 176 such that cable 184 is attached at one end to the return spring 240, at the other end to the drive pulley 176. The cable 186 is attached to the return pulley 174 and then cable 186 attaches to the very proximal end of the handle 160, thus forming a loop. The return spring 240 can be set to a desired spring-rate so that the return spring 240 performs as desired by the user. The return spring 240 should have a small amount of preload to make sure that the handle 160 opens all the way, which provides that the driving mechanism 170 would return the needle 220 to the home position.

[0103] The cables 184 and 186 extend through the elongated barrel 154 and connect to the drive mechanism 170 in the suture head assembly 156. The long length of the cables 184 and 186 provides a small amount of a spring buffer. If the suturing device 150 were to become bound or something locked up at the suture head assembly 156 this would not translate. If the user continued to pull on the handle 160 to close the handle 160, the cables 184 and 186 would stretch and should not break. The two idler pulleys 180, which drive the cables 184 and 186 are located in the spherical portion 158. As shown in FIG. 39, the two idler pulleys 180 appear to be one on top of the other, but they are located in a plane with either pulleys 174 and 176 or pulley 178.

[0104] In an embodiment, the entire suturing device 150 can be designed as a single unit which may be either reusable or disposed after a single use. In an embodiment, the entire suturing device 150 can be designed from a number of separable parts where each unit may be either reusable or disposed after a single use.

[0105] The suturing device 150 is configured to provide a "pistol like" grip for the user that includes an elongated barrel 154 and a handle 160 that extends from the proximal end of the elongated barrel 154. The elongated barrel 154 has either a linear or non-linear configuration, including but not limited to, straight, curved and angled configurations. A suture head assembly 156 is removably attached to the distal end of the elongated barrel 154. The suture head assembly 156 contains a portion of the drive mechanism 170 of the device 150. The working end of the suture head assembly 156 has a needle holder assembly 188 to which a suturing needle 220 may reside. A latch 210 forms a cover over the needle 220.

[0106] An arcuate suturing needle 220 having a sharp, pointed end 224 is slidably mounted in a circular track 192 of the needle holder assembly 188. The blunt end of the needle 226 is connected to the suturing material or thread 246. The needle 220 normally resides in a "home" position in the track 192 such that the gap in the arcuate suturing needle 222 is in alignment with an aperture 218 in the needle holder assembly 188. The sharp, pointed end of the needle 224 is situated on one side and entirely within the confines of the needle holder aperture 218; the pointed end of the needle 224 is, therefore, shielded by the needle holder assembly 188. The blunt end of the suturing needle 226 that is attached to the suturing material or thread 246 is located at the opposite side of the aperture 218. The sharp, pointed end of the needle 224 is, therefore, wholly contained within the needle holder assembly 188 and does not protrude beyond the housing of the needle holder assembly 188. Thus, the sharp pointed end of the needle 224 is not exposed to the user.

[0107] In accordance with the presently disclosed embodiments, the needle 220 may be releasably engaged by the needle driver 198 that is rotatably mounted within the suture head assembly 156 so that the needle 220 can be rotated from the home position by about 360° about the central vertical axis of the needle holder assembly 188. Such a rotary action of the needle 220 causes the sharp point 224 to advance across the needle holder assembly 188 so as to span the aperture 218. Thus, when the device 150 is positioned such that the incised tissue segments to be sutured are situated at the needle holder assembly aperture 218, the needle 220 penetrates the tissue segments and spans the incision between them. A continued rotary movement of the needle 220 causes the needle 220 to return to the home position, and thereby causes the suturing material or thread 246 attached to the needle 220 to be pulled into and through the tissue in an inward direction on one side of the tissue incision, and upwards and out through the tissue on the opposite side of the incision. Thus, the suture material or thread 246 follows the curved path of the needle 220 to bind the tissues together with a stitch of material or thread 246 across the incision in a manner similar to manual suturing, wherein the needle 220 is "pushed" from the blunt end 226 and then "pulled" from the pointed end 224 by the pawl 198. Preferably, an anchoring mechanism is provided at the trailing terminal end of the suturing material or thread 246 to prevent the material 246 from being pulled completely through and out of the tissue segments. For example, the anchoring mechanism can be a pre-tied or a welded loop, a knot wherein the suture material or thread 246 is simply tied, or a double-stranded, looped suture is that attached to the suturing needle 220. The rotary movement of the needle 220 within the needle holder assembly 188 is accomplished by a pawl 198 that may be operated by the user by holding the suturing device 150 with one hand in a pistol-like grip around the handle 160, and using at least one finger of that hand to activate.

[0108] The suturing device 150 of the presently disclosed embodiments can be used for a laparoscopic procedure, including but not limited to laparoscopic colostomy, colectomy, adrenalectomy, splenectomy, repair of paraesophageal hernia, inguinal hernia repair, ventral hernia repair, Nissen fundoplication, liver lobectomy, gastrectomy, small bowel resection, treatment of small bowel obstruction, distal pancreatectomy, nephrectomy and gastric bypass. Those skilled in the art will recognize that the presently disclosed embodiments can be used in other laparoscopic procedures.

[0109] In using the device 150 of the presently disclosed embodiments, the abdomen is insufflated with gas to create a working space for the user. Any gas known to those skilled in the art including, but not limited to, nitrogen or carbon dioxide, can be used. Access portals are established using trocars in locations to suit the particular surgical procedure. A variety of surgical instruments may then be inserted into the body through these access ports/cannulas. The user then introduces the distal end portion of suturing device 150 into a cannula, and then laterally articulates the suture head assembly 156 using the articulation lever 166 located just distal to the top of the handle 160. The suture head assembly 156 is then positioned relative to the tissue/vessel to be sutured together, and the user locks the suture head assembly 156 in place using the locking lever 164. The user then, through manipulation of the suturing device 150, positions a plurality of separated tissue segments into the opening defined at the distal end portion of the suture head assembly 156 and within the aperture 218 of the needle holder assembly 188. The user, using only one hand, may manipulate the device 150 while actuating the handle 160 to close an incision with a continuous suture whose stitches may be individually tensioned precisely and uniformly along the length of the suture similar to suturing done by hand in the conventional way. The user may employ a single suture which would extend the entire length of the incision or multiple sutures. Thus, by placement of the device 150 with the needle holder assembly aperture 218 spanning the incised tissue segments and actuating the handle 160, the suturing device 150 enables the user to lay down a running stitch or interrupted stitch to close the tissue incision in a time efficient manner. Those skilled in the art will recognize that any conventional procedure for conducting laparoscopic surgery can be used with the device 150.

[0110] The minimized structural design of the suture head assembly 156 enables the user to have a clear, unobstructed view of the suturing needle 220 during advancement through the tissue segments during the course of a suturing operation, thereby enabling precise placement of the suturing device 150 to provide uniform sutures and precluding the risk of tearing tissue by placement too close to the edge of the incision. The suturing device 150 is then advanced a short distance along the incision and the aforementioned operation is repeated to produce another stitch comprising the suturing material or thread 246.

[0111] The user may continue to manipulate the suturing device 150, alternately advancing and actuating rotation of the needle 220 about an axis that is generally parallel to the direction of advancement to create a continuous suture which may extend through the entire length of the incision or a series of interrupted stitches. After each individual stitch is laid down, the stitch is tightened by exerting a pull on the suturing material or thread 246 so that the resultant suture is tensioned uniformly along the length of the incised tissue segments. Therefore, a tight closure of the segments is accomplished and bleeding and tearing of tissue are minimized. Once the appropriate amount of suture material or thread 246 has been placed, the user can use a needle grasper to tighten and knot the formed stitches.

[0112] The suturing device 150 may be configured in different ways with respect to length and angle of the suture head assembly 156. The size of the needle 220, the needle holder assembly 188, the needle holder aperture 218 and the aperture position may also be varied for use in open surgery to perform

procedures such as closing of the fascia, skin closure, soft tissue attachment, anastomosis, fixation of mesh, grafts and other artificial materials.

[0113] In accordance with another aspect of the invention, a suturing device is provided in accordance with the teachings of issued U.S. Pat. No. 6,923,819, which is incorporated by reference herein in its entirety. In accordance with a preferred embodiment, a suturing device is provided accordingly that may have a very small working end or tip at the end of a long rigid shaft or a flexible shaft that can be oriented in any preferred direction so that the instrument may be used for MIS, such as suturing in the course of endoscopic surgery, including laparoscopy, thoracoscopy and arthroscopy, as well as less-invasive surgical procedures.

[0114] All patents, patent applications, and published references cited herein are hereby incorporated by reference in their entirety. It will be appreciated that various of the above-disclosed and other features and functions, or alternatives thereof, may be desirably combined into many other different systems or applications. Various presently unforeseen or unanticipated alternatives, modifications, variations, or improvements therein may be subsequently made by those skilled in the art which are also intended to be encompassed by the following claims.

What is claimed is:

1. A surgical suturing apparatus, comprising:

- a) a suture housing;
- b) a needle mounted within the suture housing for movement about an arcuate path;
- c) a drive assembly operably associated with the needle for controlling movement of the needle with a suture secured thereto about the arcuate path in a manner facilitating application of the suture to tissue; and
- d) wherein the suture housing has an open position and a closed position, and the needle can be removed from the suture housing when in the open position.

2. The suturing apparatus according to claim 1, wherein the drive assembly moves the needle about a continuous circular path.

3. The suturing apparatus according to claim 1, wherein the suture housing is shaped and dimensioned for insertion through a natural orifice of a patient.

4. The suturing apparatus according to claim 1, wherein the suture housing is shaped and dimensioned for laparoscopic insertion through a trocar.

5. The suturing apparatus according to claim 1, wherein the suture housing includes a first housing member and a second housing member, and a hinge connects the first housing member and the second housing member.

6. The suturing apparatus according to claim 1, wherein a needle may be reloaded within the suture housing when in its open position.

7. A surgical suturing apparatus shaped and dimensioned for insertion through a natural orifice of a patient, comprising:

- a) a suture housing;
- b) a needle mounted within the suture housing for movement about an arcuate path;
- c) a drive assembly operably associated with the needle for controlling movement of the needle with a suture secured thereto about the arcuate path in a manner facilitating application of the suture to tissue; and
- d) wherein the suture housing has an open position and a closed position, wherein the needle can be removed from the suture housing when in the open position.

8. A surgical suturing apparatus shaped and dimensioned for laparoscopic insertion through a trocar, comprising:

- a) a suture housing;
- b) a needle mounted within the suture housing for movement about an arcuate path;
- c) a drive assembly operably associated with the needle for controlling movement of the needle with a suture secured thereto about the arcuate path in a manner facilitating application of the suture to tissue; and
- d) wherein the suture housing has an open position and a closed position, wherein the needle can be removed from the suture housing when in the open position.

9. A surgical suturing apparatus, comprising:

- a) a suture housing;
- b) a needle having a proximal end and a distal end, the needle being mounted within the suture housing for movement about an arcuate path;
- c) a drive assembly operably associated with the needle for controlling movement of the needle with a suture secured thereto about the arcuate path in a manner facilitating application of the suture to tissue; and
- d) means for determining the position of a predetermined point on the needle relative to the needle's path of travel when the predetermined point not visually detectable.

10. A surgical suturing apparatus, comprising:

- a) a suture housing;
- b) a needle mounted within the suture housing for movement about an arcuate path;
- c) a drive assembly operably associated with the needle for controlling movement of the needle with a suture secured thereto about an arcuate path in a first direction in a manner facilitating application of the suture to tissue; and
- d) an anti-backup mechanism associated with the needle for preventing movement of the needle in a second direction opposite to the first direction.

11. The suturing apparatus according to claim 10, wherein the drive assembly moves the needle about a continuous circular path.

12. The suturing apparatus according to claim 10, wherein the suture housing is shaped and dimensioned for insertion through a natural orifice of a patient.

13. The suturing apparatus according to claim 10, wherein the suture housing is shaped and dimensioned for laparoscopic insertion through a trocar.

14. The suturing apparatus according to claim 10, wherein the anti-backup mechanism includes a lever arm secured to the suture housing for selectively engaging the needle.

15. The suturing apparatus according to claim 14, wherein the lever arm is pivotally secured to the suture housing.

16. The suturing apparatus according to claim 10, wherein the anti-backup mechanism includes a biased latch mounted within the suture housing for selectively engaging the needle.

17. The suturing apparatus according to claim 10, wherein the anti-backup mechanism further prevents the needle from moving between actuations of the drive assembly.

18. A surgical suturing apparatus shaped and dimensioned for insertion through a natural orifice of a patient, comprising:

- a) a suture housing;
- b) a needle mounted within the suture housing for movement about an arcuate path;
- c) a drive assembly operably associated with the needle for controlling movement of the needle with a suture

secured thereto about an arcuate path in a first direction in a manner facilitating application of the suture to tissue; and

- d) an anti-backup mechanism associated with the needle for preventing movement of the needle in a second direction opposite to the first direction.

19. The suturing apparatus according to claim **18**, wherein the drive assembly moves the needle about a continuous circular path.

20. The suturing apparatus according to claim **18**, wherein the anti-backup mechanism includes a lever arm secured to the suture housing for selectively engaging the needle.

21. The suturing apparatus according to claim **18**, wherein the anti-backup mechanism includes a biased latch mounted within the suture housing for selectively engaging the needle.

22. A surgical suturing apparatus shaped and dimensioned for laparoscopic insertion through a trocar, comprising:

- a) a suture housing;
- b) a needle mounted within the suture housing for movement about an arcuate path;
- c) a drive assembly operably associated with the needle for controlling movement of the needle with a suture secured thereto about an arcuate path in a first direction in a manner facilitating application of the suture to tissue; and
- d) an anti-backup mechanism associated with the needle for preventing movement of the needle in a second direction opposite to the first direction.

23. The suturing apparatus according to claim **22**, wherein the drive assembly moves the needle about a continuous circular path.

24. The suturing apparatus according to claim **22**, wherein the anti-backup mechanism includes a lever arm secured to the suture housing for selectively engaging the needle.

25. The suturing apparatus according to claim **22**, wherein the anti-backup mechanism includes a biased latch mounted within the suture housing for selectively engaging the needle.

26. A surgical suturing apparatus, comprising:

- a) a flexible member having a proximal end and a distal end, the proximal end having a handle attached thereto, the distal end having a suturing body attached thereto, wherein the handle is operatively connected to the suturing body;
- b) the suturing body comprising a suture housing in which a needle and drive assembly are housed for movement of the needle with a suture secured thereto about an arcuate path facilitating application of a suture to tissue; and
- c) means for accommodating and operating different sized needles and different sized sutures while maintaining the operative connection between the handle and the suturing body.

27. The suturing apparatus according to claim **26**, wherein the means for accommodating includes a cartridge housing the needle.

28. The suturing apparatus according to claim **26**, wherein the drive assembly moves the needle about a continuous circular path.

29. The suturing apparatus according to claim **26**, wherein the suture housing is shaped and dimensioned for insertion through a natural orifice of a patient.

30. The suturing apparatus according to claim **26**, wherein the suture housing is shaped and dimensioned for laparoscopic insertion through a trocar.

31. A surgical suturing apparatus shaped and dimensioned for insertion through a natural orifice of a patient, comprising:

- a) a flexible member having a proximal end and a distal end, the proximal end having a handle attached thereto, the distal end having a suturing body attached thereto, wherein the handle is operatively connected to the suturing body;
- b) the suturing body comprising a suture housing in which a needle and drive assembly are housed for movement of the needle with a suture secured thereto about an arcuate path facilitating application of a suture to tissue; and
- c) means for accommodating and operating different sized needles and different sized sutures while maintaining the operative connection between the handle and the suturing body.

32. The suturing apparatus according to claim **31**, wherein the means for accommodating includes a cartridge housing the needle.

33. A surgical suturing apparatus shaped and dimensioned for laparoscopic insertion through a trocar, comprising:

- a) a flexible member having a proximal end and a distal end, the proximal end having a handle attached thereto, the distal end having a suturing body attached thereto, wherein the handle is operatively connected to the suturing body;
- b) the suturing body comprising a suture housing in which a needle and drive assembly are housed for movement of the needle with a suture secured thereto about an arcuate path facilitating application of a suture to tissue; and
- c) means for accommodating and operating different sized needles and different sized sutures while maintaining the operative connection between the handle and the suturing body.

34. The suturing apparatus according to claim **33**, wherein the means for accommodating includes a cartridge housing the needle.

35. A method for suture lacing, comprising:

- a) providing a suture with a needle attached thereto;
- b) inserting the needle and suture into an organ through a passageway;
- c) throwing a single stitch through a first tissue member, throwing a single stitch through an opposed and spaced apart second tissue member;
- d) repeating step (c) at least once;
- e) bringing the first and second tissue members in contact by tensioning the suture, whereby suture drag is minimized during the tensioning and even tissue compression substantially achieved; and
- f) securing the suture.

36. The method according to claim **35**, wherein the suture includes first and second leads, and the step of securing includes knotting the first and second leads of the suture.

37. The method according to claim **35**, wherein the suture includes first and second leads and the step of securing includes anchoring at least one of the first and second leads of the suture to tissue.

38. The method according to claim **37**, wherein the step of securing includes anchoring both the first and second leads of the suture to tissue.

39. The method according to claim **35**, wherein the step of inserting includes insertion through a natural orifice of a patient.

40. The method according to claim **35**, wherein the step of inserting includes insertion through a trocar.

- 41.** A method for suture lacing, comprising:
- a) inserting a needle with a suture secured thereto through a passageway, wherein the suture includes a first lead and a second lead;
 - b) anchoring the first lead of the suture to a first tissue member;
 - c) alternately throwing the suture through a first tissue member and an opposed second tissue member; and
 - d) securing the suture.

42. The method according to claim **41**, further including the step of anchoring the second lead to either the first tissue member or the second tissue member.

43. The method according to claim **41**, wherein the step of inserting includes insertion through a natural orifice of a patient.

44. The method according to claim **41**, wherein the step of inserting includes insertion through a trocar.

* * * * *

专利名称(译)	用于微创缝合的装置和方法		
公开(公告)号	US20080255590A1	公开(公告)日	2008-10-16
申请号	US11/982174	申请日	2007-11-01
[标]申请(专利权)人(译)	米德约翰·C· 格里菲思杰里 - [R DIFRANCESCO FRANCIS J		
申请(专利权)人(译)	米德约翰·C· 格里菲思杰里 - [R DIFRANCESCO FRANCIS J		
当前申请(专利权)人(译)	ENDOEVOLUTION , LLC		
[标]发明人	MEADE JOHN C GRIFFITHS JERRY R DIFRANCESCO FRANCIS J		
发明人	MEADE, JOHN C. GRIFFITHS, JERRY R. DIFRANCESCO, FRANCIS J.		
IPC分类号	A61B17/062		
CPC分类号	A61B17/0469 A61B17/0482 A61B17/06066 A61B17/0625 A61B2017/06028 A61B2017/2923 A61B2017/2927 A61B2017/2943		
优先权	60/611362 2004-09-20 US		
外部链接	Espacenet USPTO		

摘要(译)

公开了一种用于微创缝合的装置和方法。一种用于微创缝合的缝合装置，包括细长的筒，所述细长的筒具有近端，远端和在它们之间的纵向轴线；缝合头组件，从细长筒的远端延伸；缝合针具有尖端和钝端，缝合针能够围绕大致垂直于细长筒的纵向轴线的轴线旋转，其中缝合针的尖端在缝合头组件之前和之前定位在缝合线头组件内。缝合针旋转后；从细长筒的近端延伸的致动器驱动机构，该驱动机构具有用于接合和旋转缝合针的针驱动器。

