



US 20080114394A1

(19) **United States**

(12) **Patent Application Publication**  
**Houser et al.**

(10) **Pub. No.: US 2008/0114394 A1**  
(43) **Pub. Date: May 15, 2008**

(54) **ARTERIOTOMY CLOSURE DEVICES AND TECHNIQUES**

filed on Jun. 25, 2001, provisional application No. 60/302,255, filed on Jun. 28, 2001.

(76) Inventors: **Russell A. Houser**, Livermore, CA (US); **William D. Hare**, Princeton, NJ (US)

**Publication Classification**

(51) **Int. Cl.**  
**A61B 17/03** (2006.01)  
(52) **U.S. Cl.** ..... **606/213**  
(57) **ABSTRACT**

Correspondence Address:  
**WILLIAM DOUGLAS HARE**  
**3 ANDERSON LANE**  
**PRINCETON, NJ 08540**

(21) Appl. No.: **11/933,129**

(22) Filed: **Oct. 31, 2007**

**Related U.S. Application Data**

(60) Division of application No. 11/279,242, filed on Apr. 10, 2006, which is a continuation of application No. 10/224,659, filed on Aug. 21, 2002, now Pat. No. 7,025,776, which is a continuation of application No. 10/127,714, filed on Apr. 23, 2002, now abandoned.

(60) Provisional application No. 60/286,269, filed on Apr. 24, 2001, provisional application No. 60/300,892,

An arterial closure system includes an arterial closure device ("ACD") and a deployment tool. The arterial closure device includes a first member forming an enlargement around the circumference of the arterial closure device and being configured to be received against an outer surface of a vessel, a connecting member having a smaller outer diameter than the first member, extending from the first member, and being configured to be positioned within an arteriotomy of a vessel, and a longitudinal channel configured to receive a tube and passing between the first member and the connecting member. The deployment tool includes a handle, a contacting section, and an extension that extends between the handle and the contacting section. The contacting section is designed to mate with the arterial closure device to advance the arterial closure device over the tube and deploy the arterial closure device within the vessel.

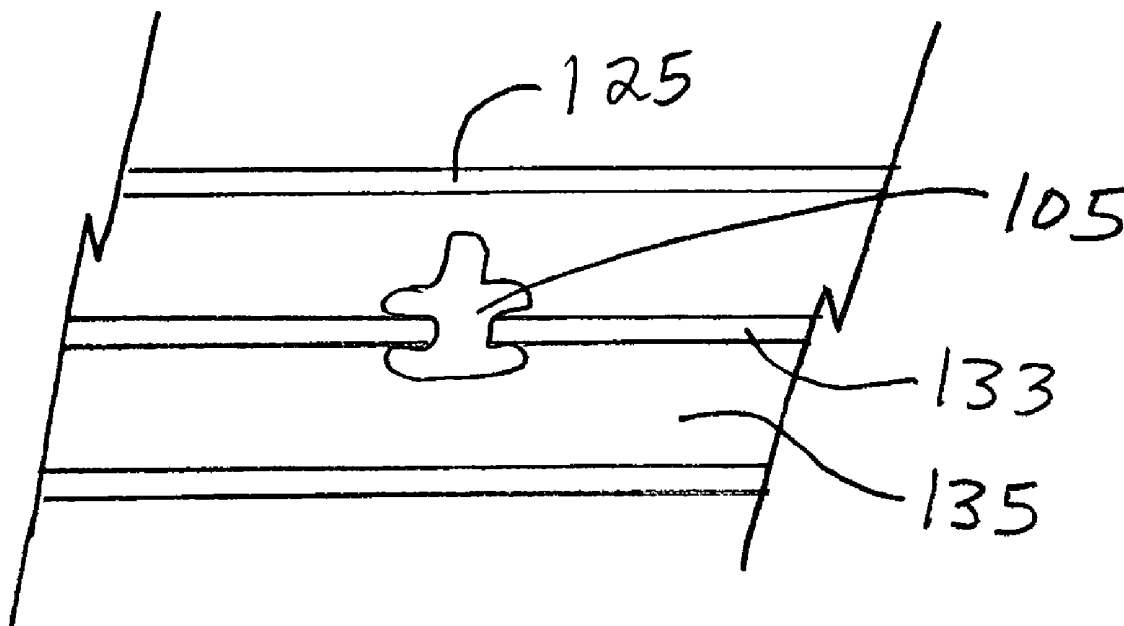

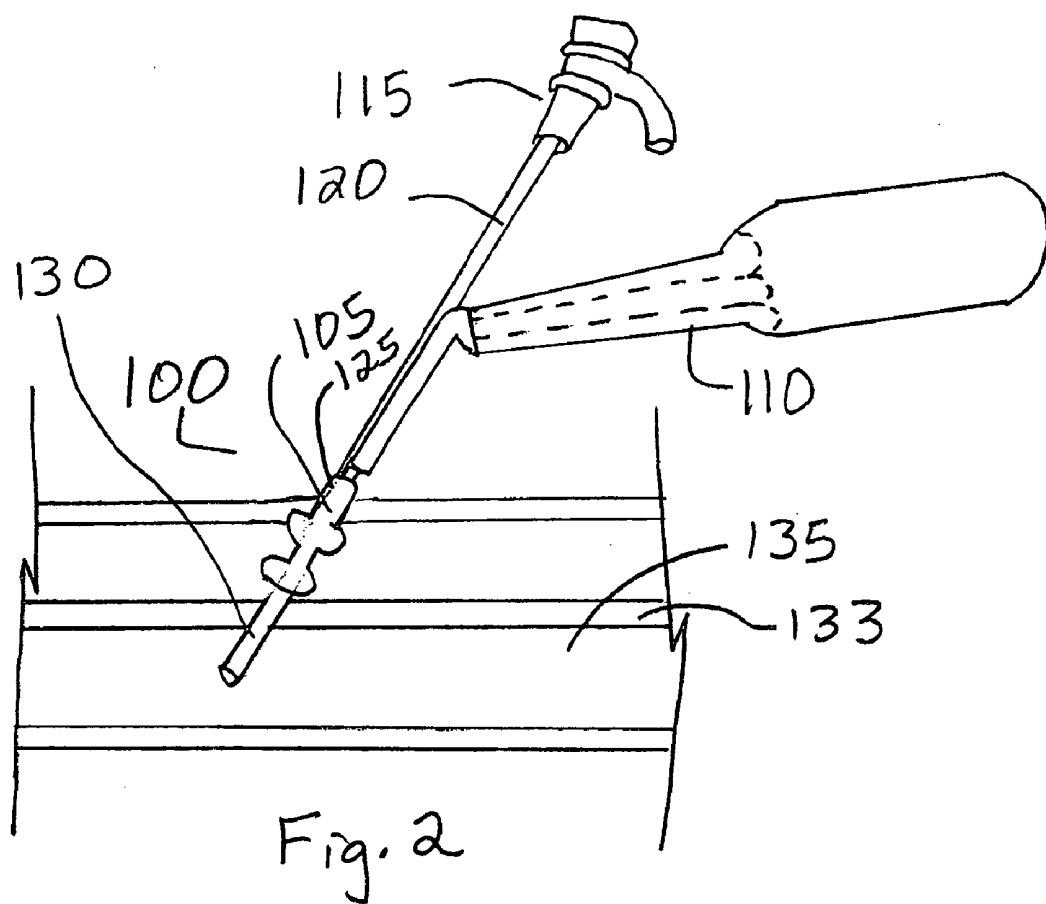
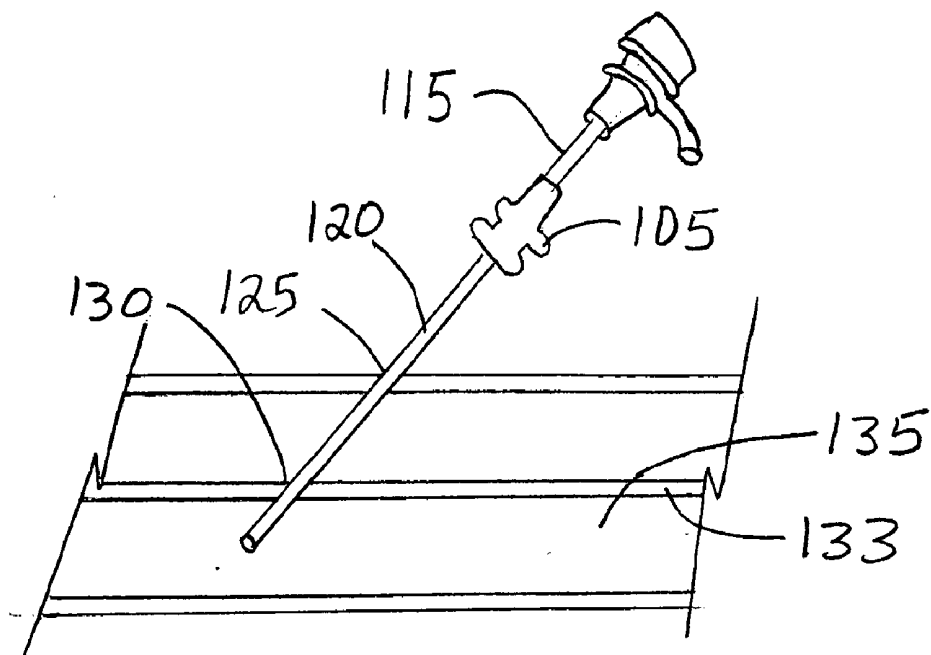

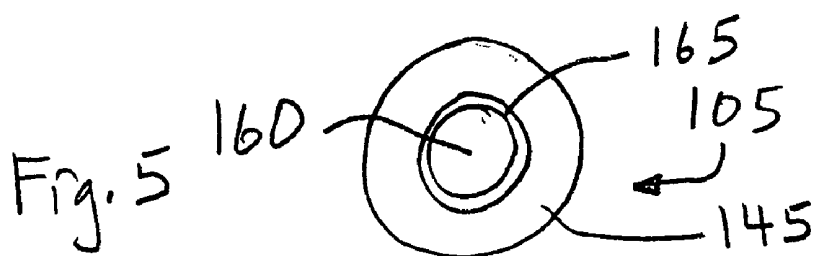
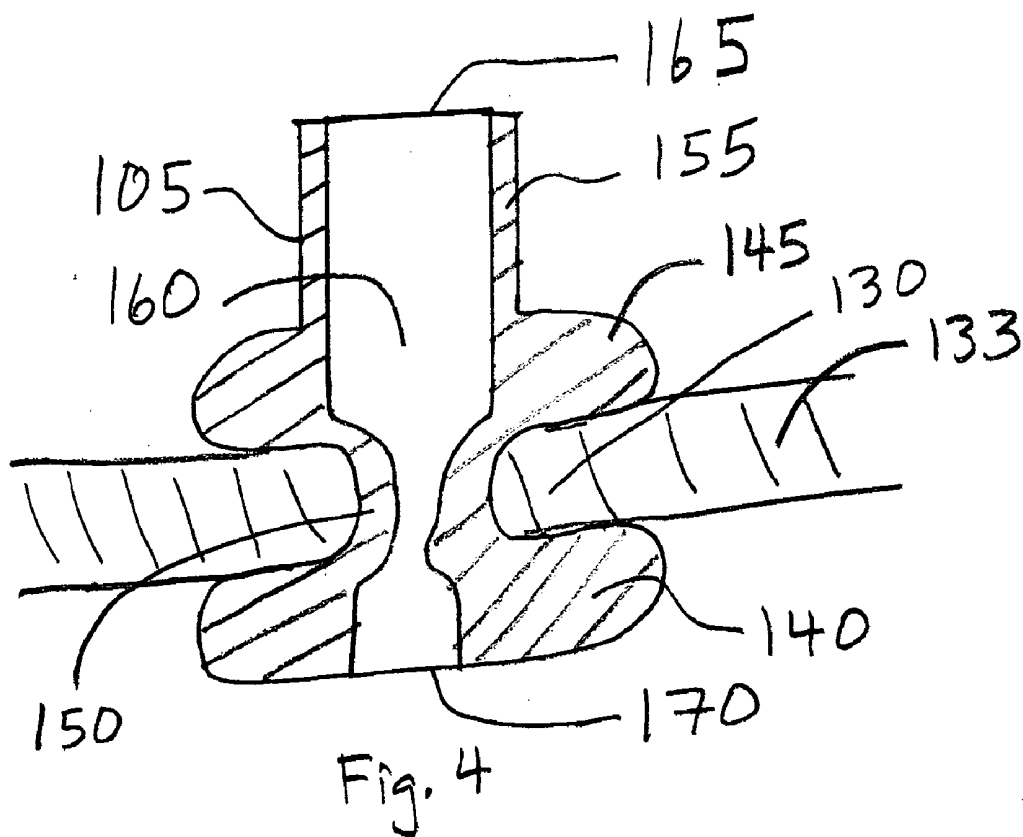
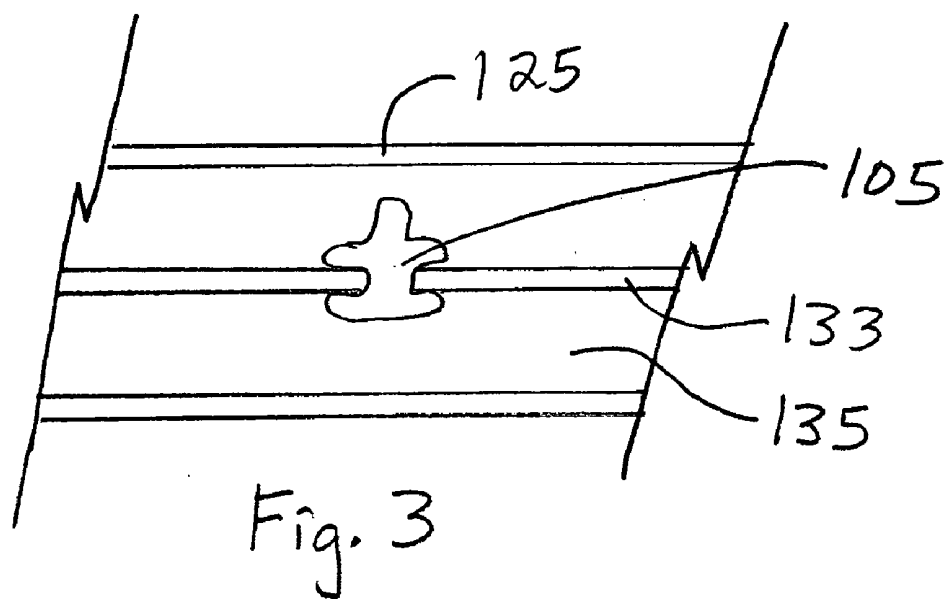

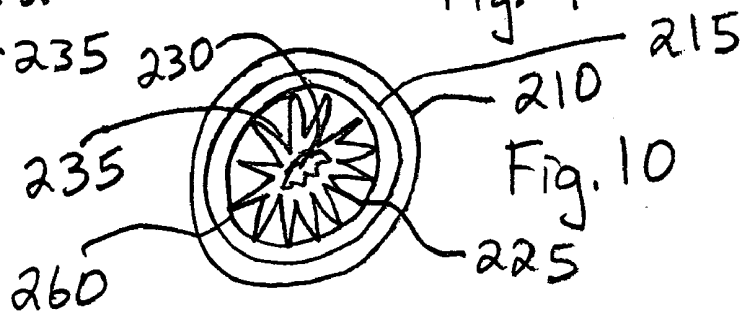
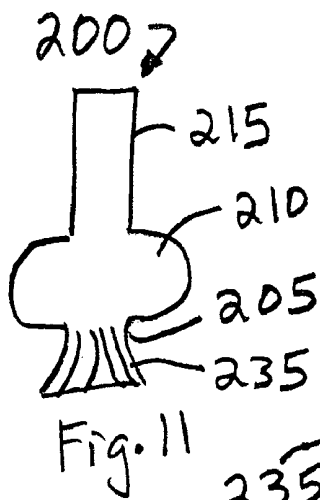
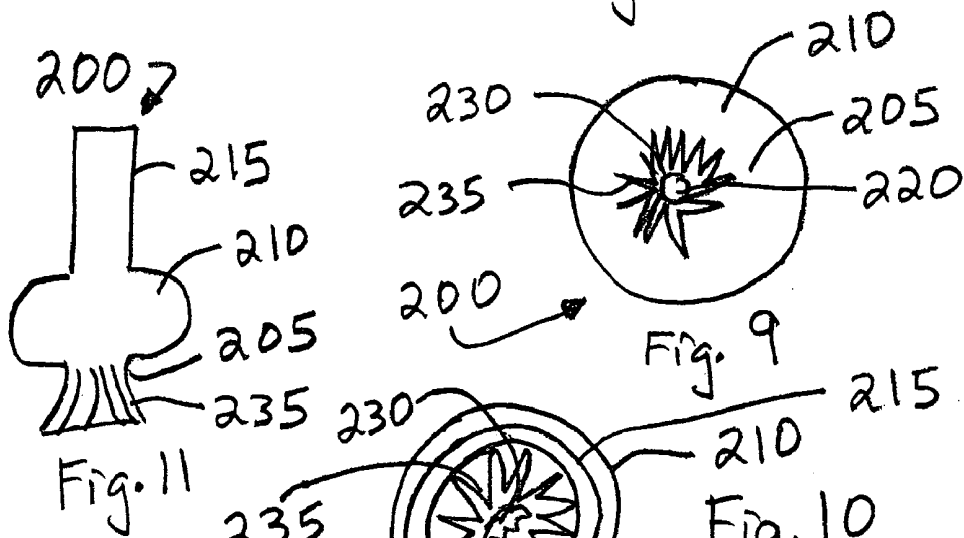
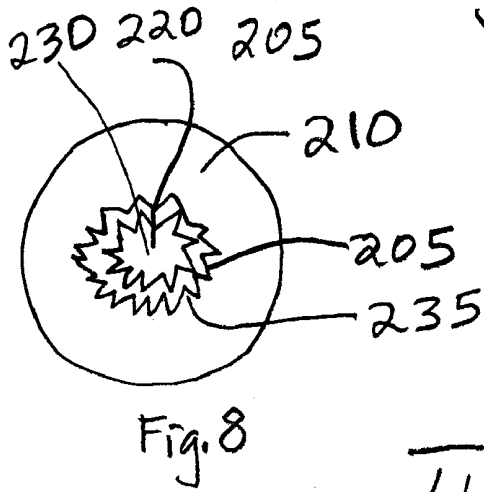
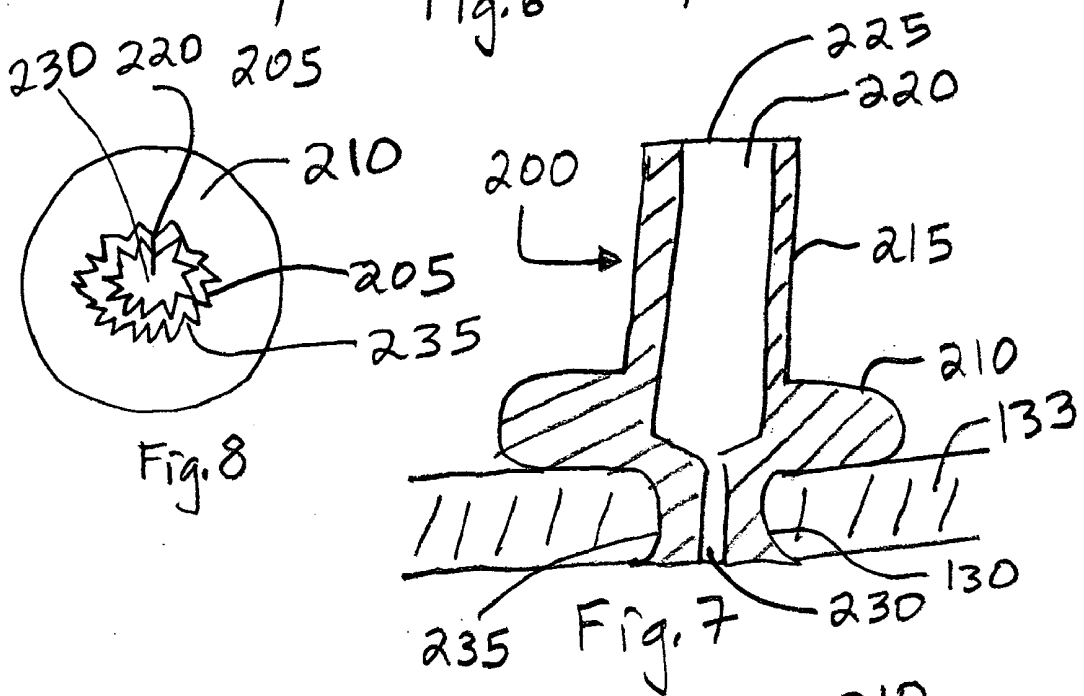
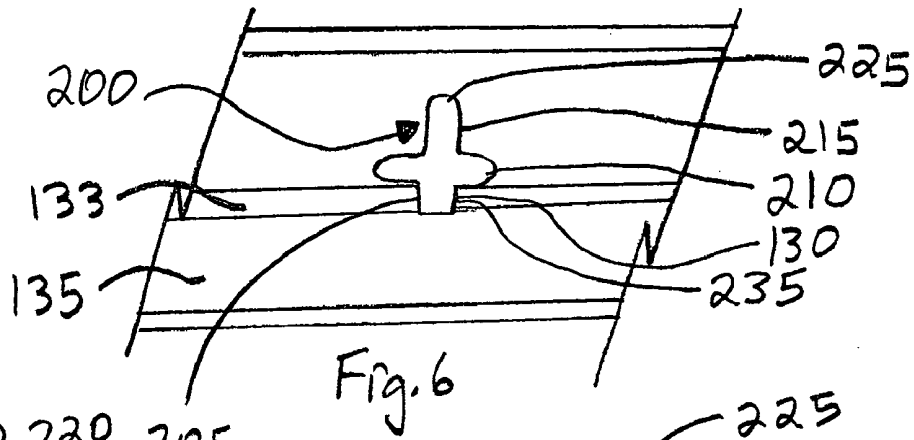

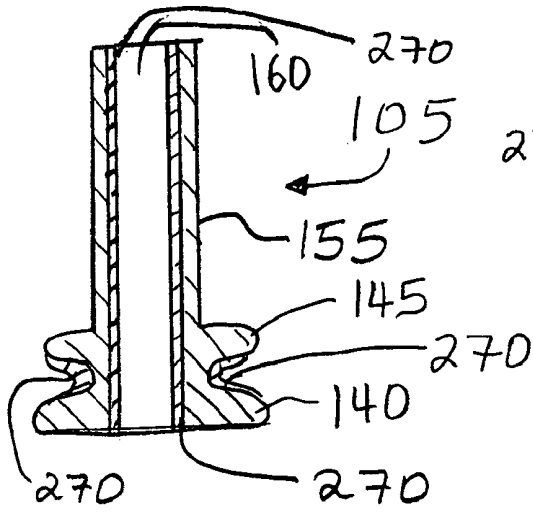

Fig. 12

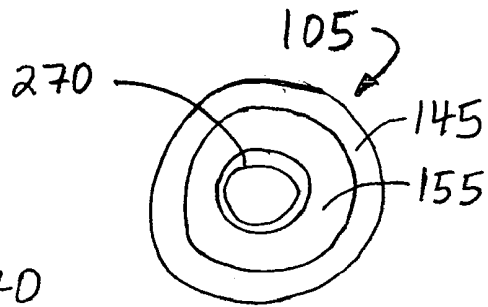

Fig. 13

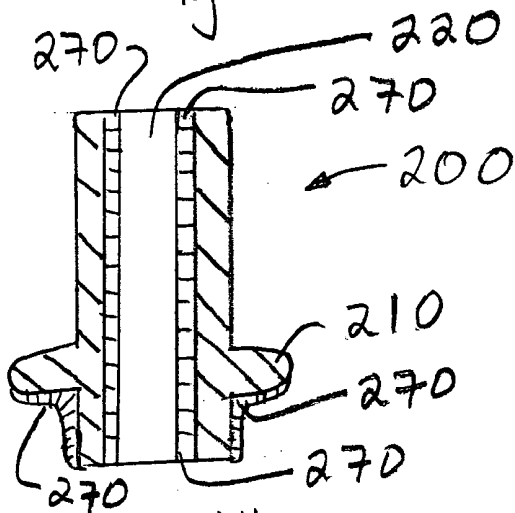

Fig. 14

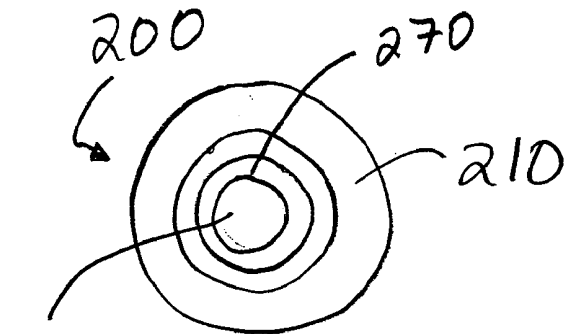

Fig. 15

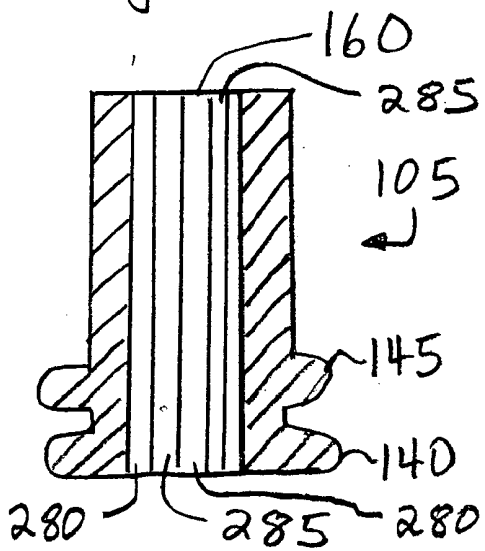

Fig. 16

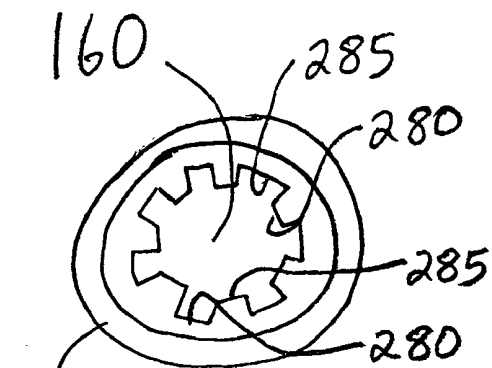

Fig. 17

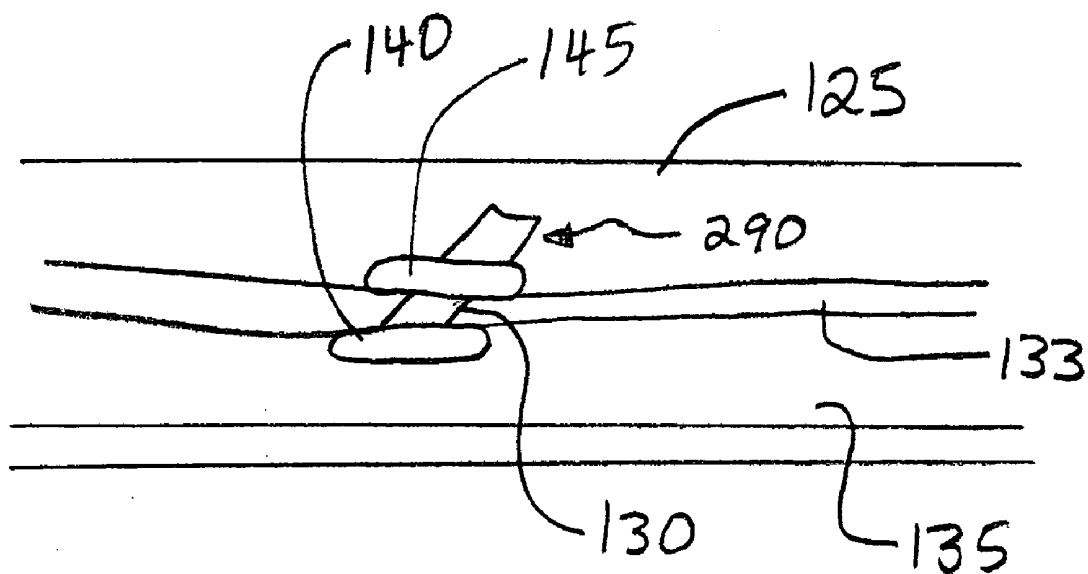

Fig. 18

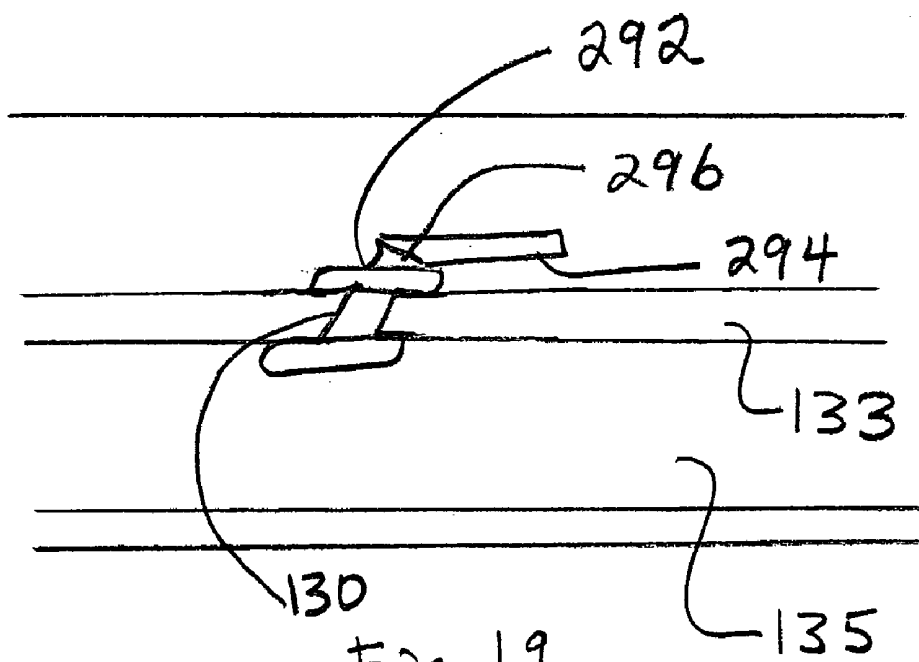
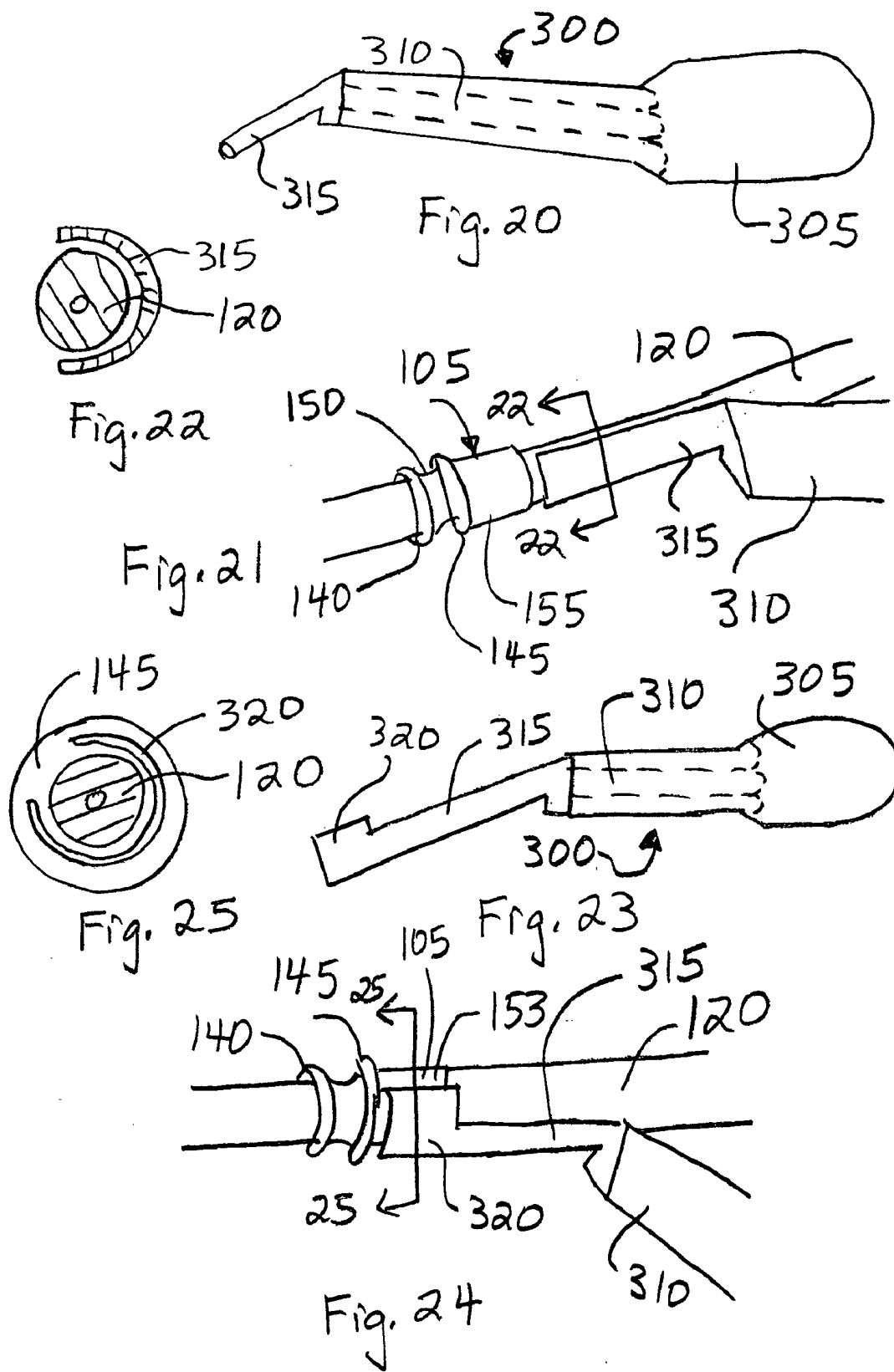
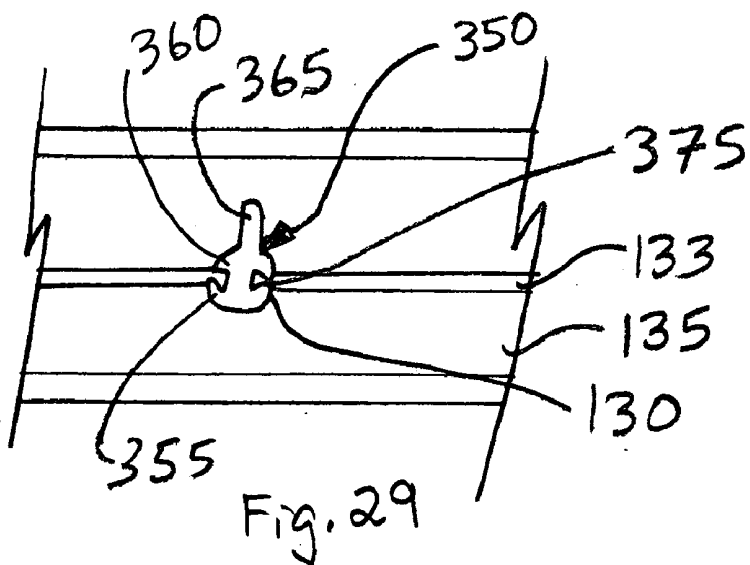
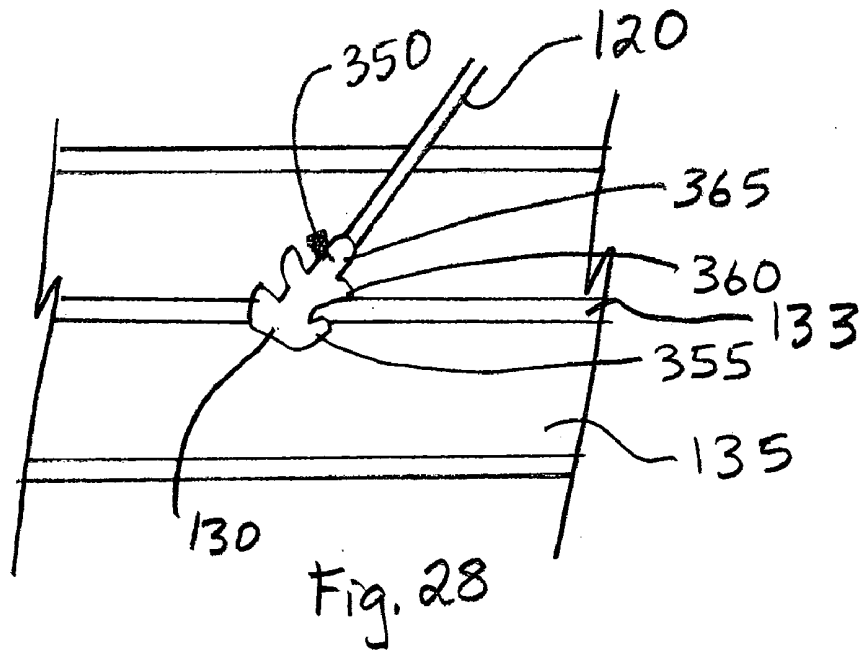
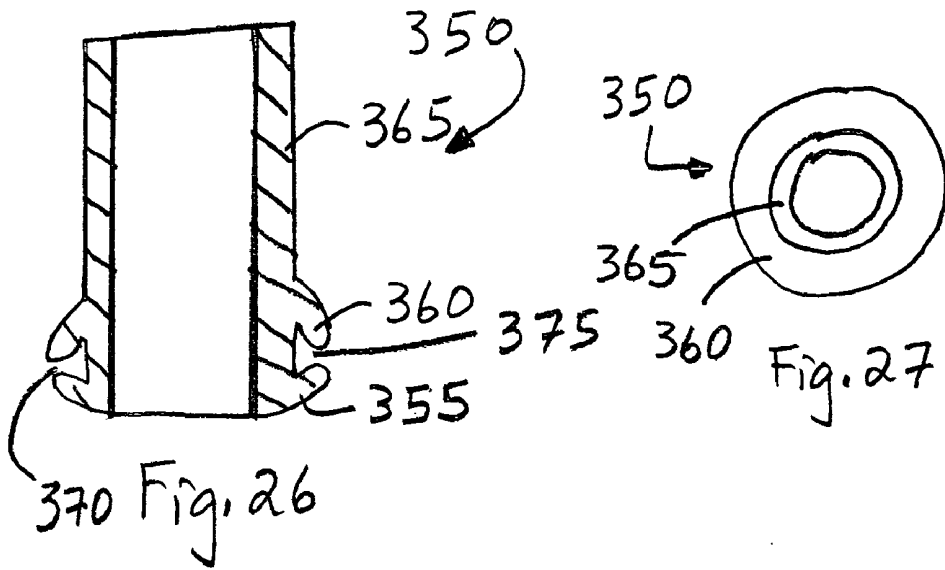
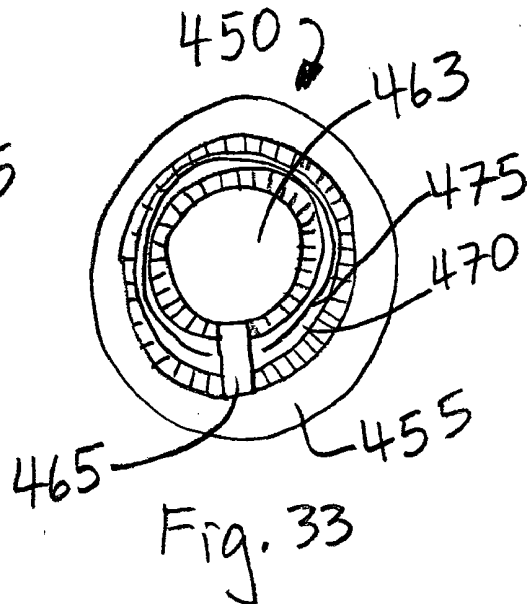
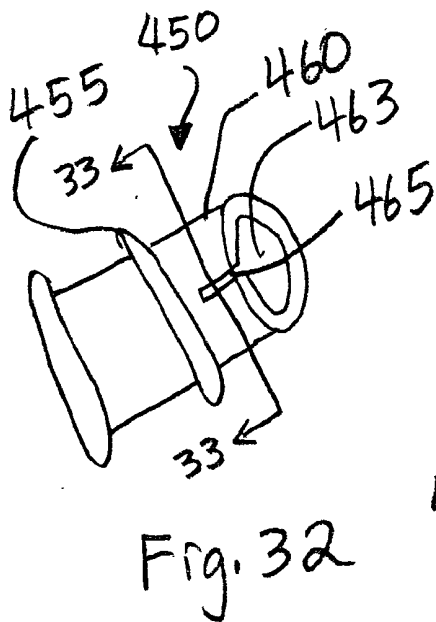
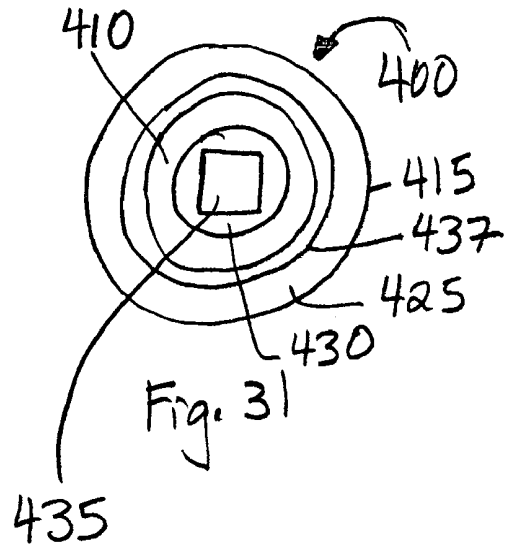
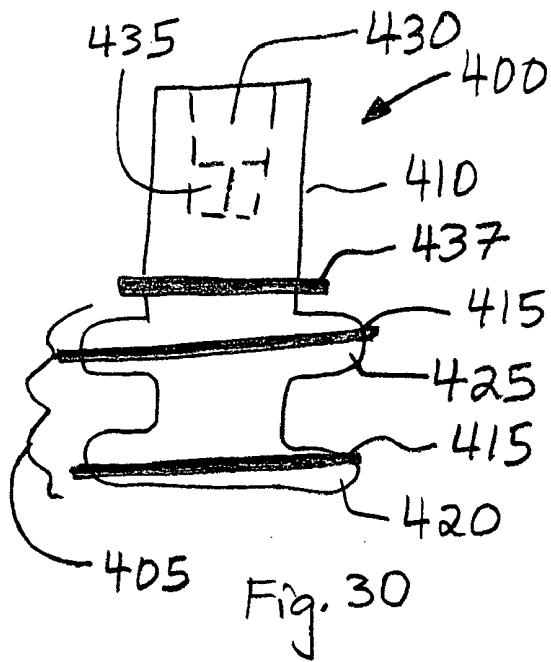

Fig. 19







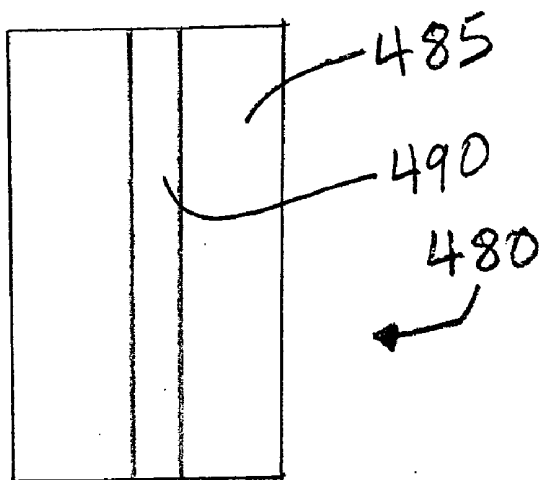

Fig. 34

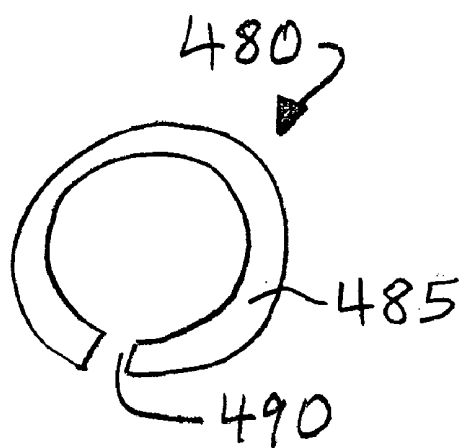

Fig. 35

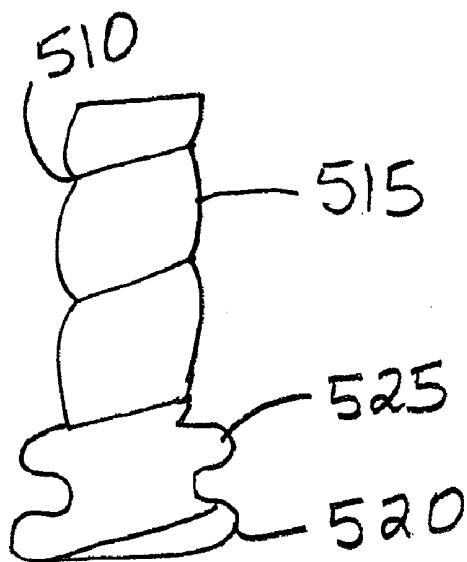

Fig. 36

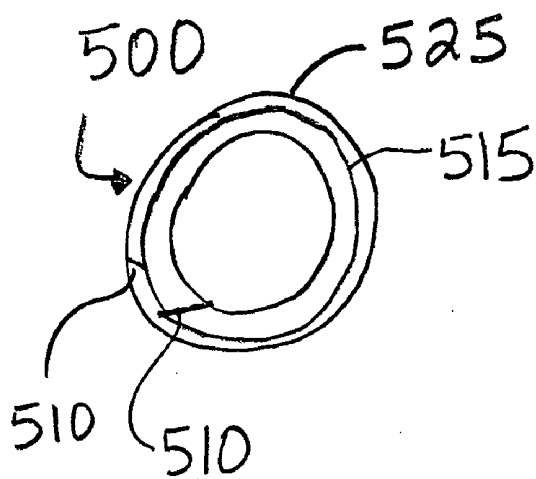
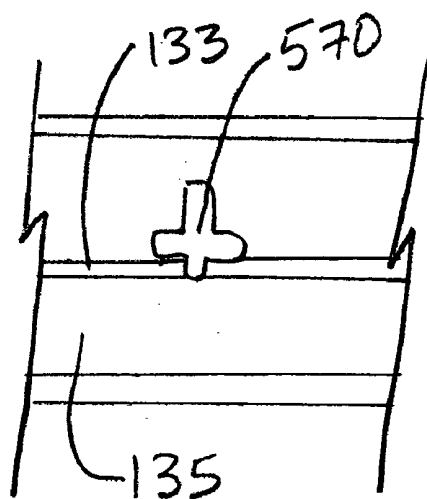
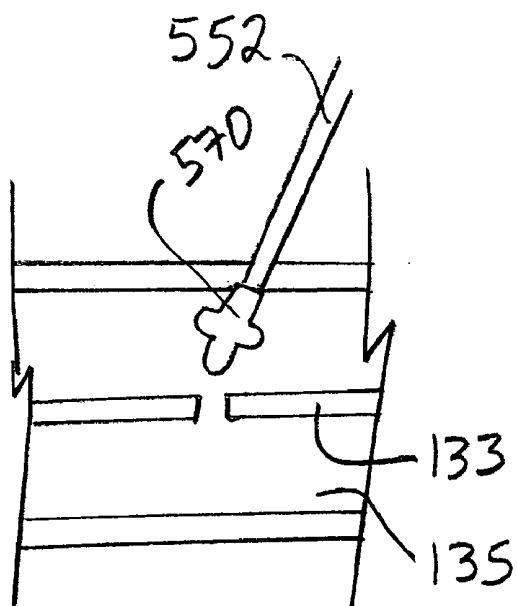
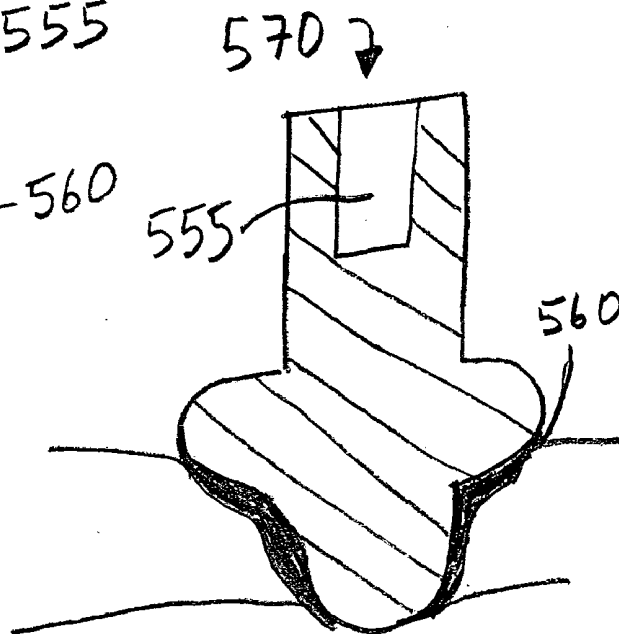
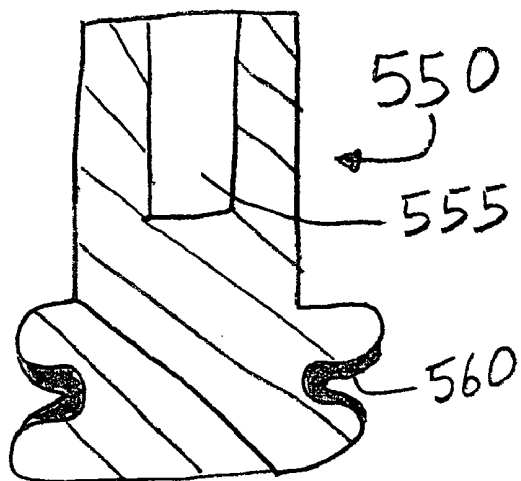

Fig. 37



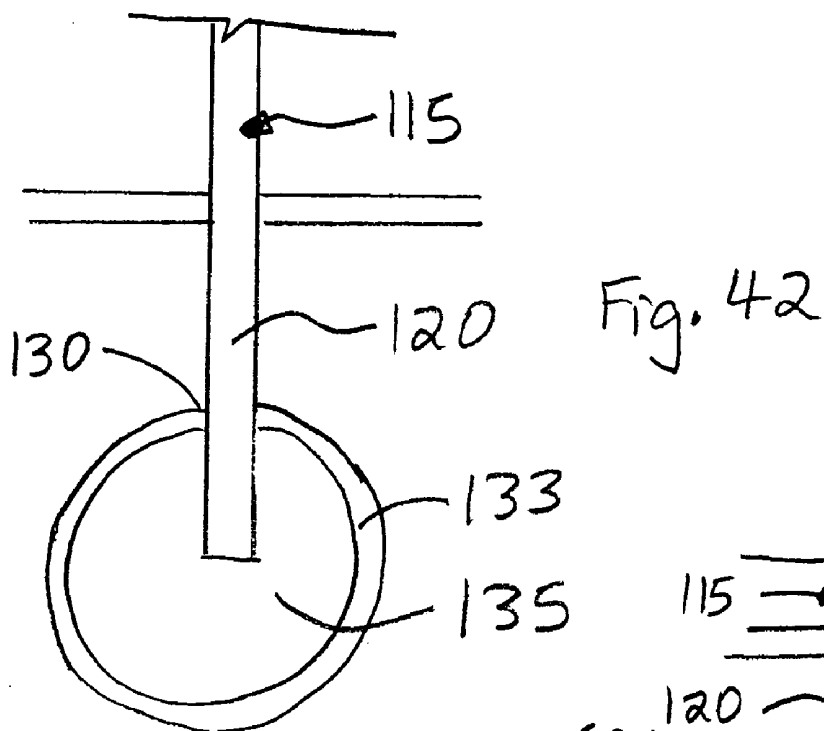
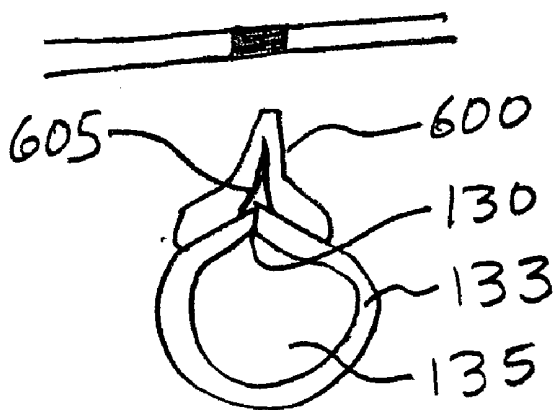
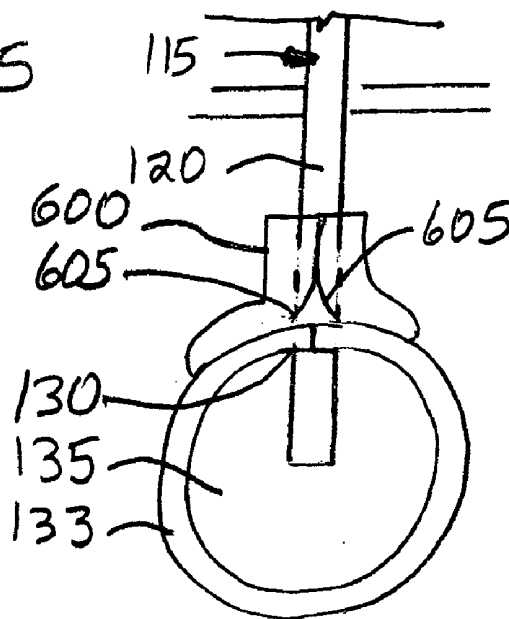

Fig. 44



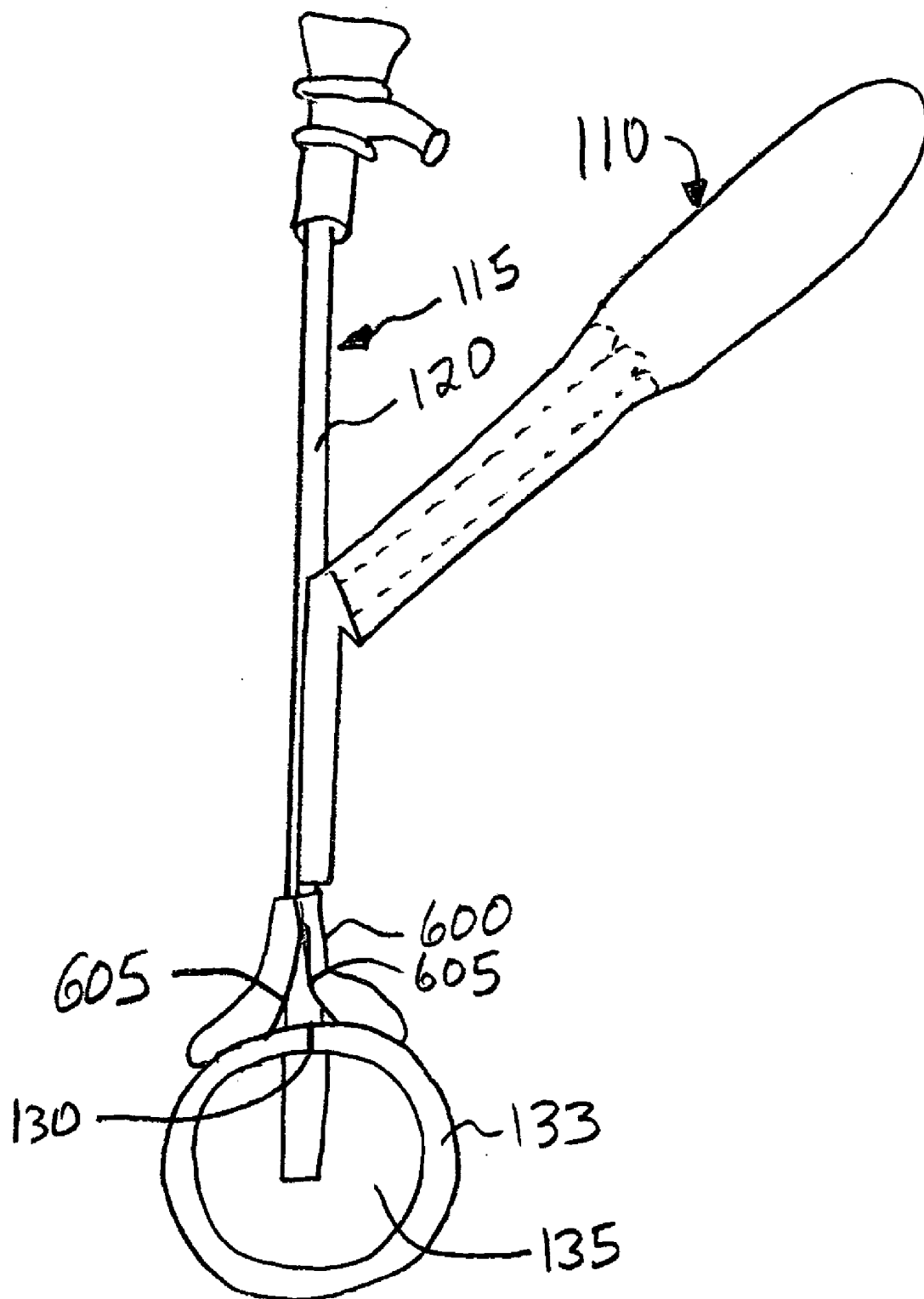

Fig. 43

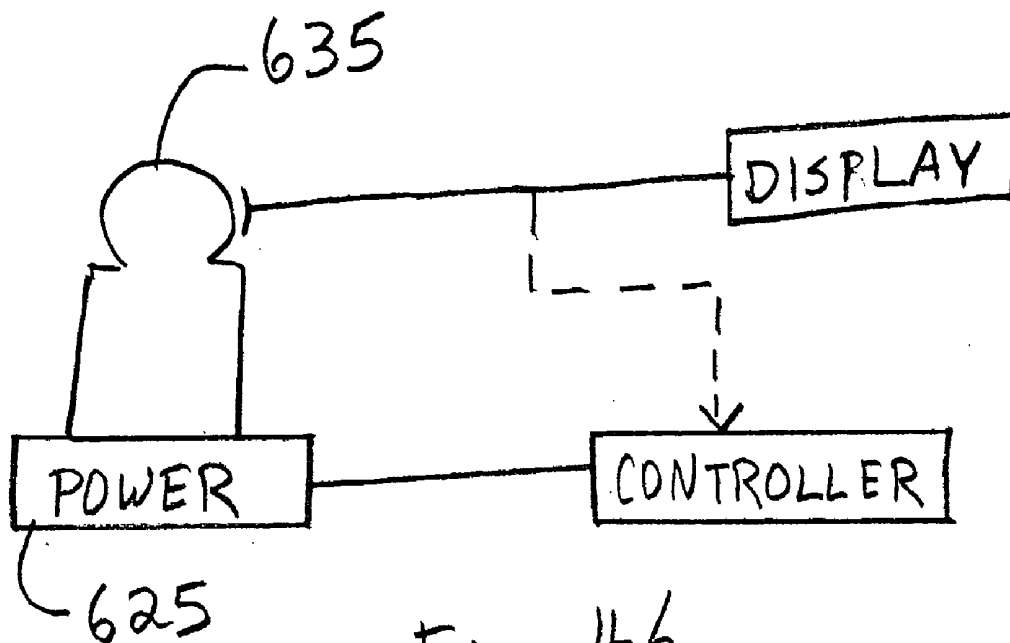

Fig. 46

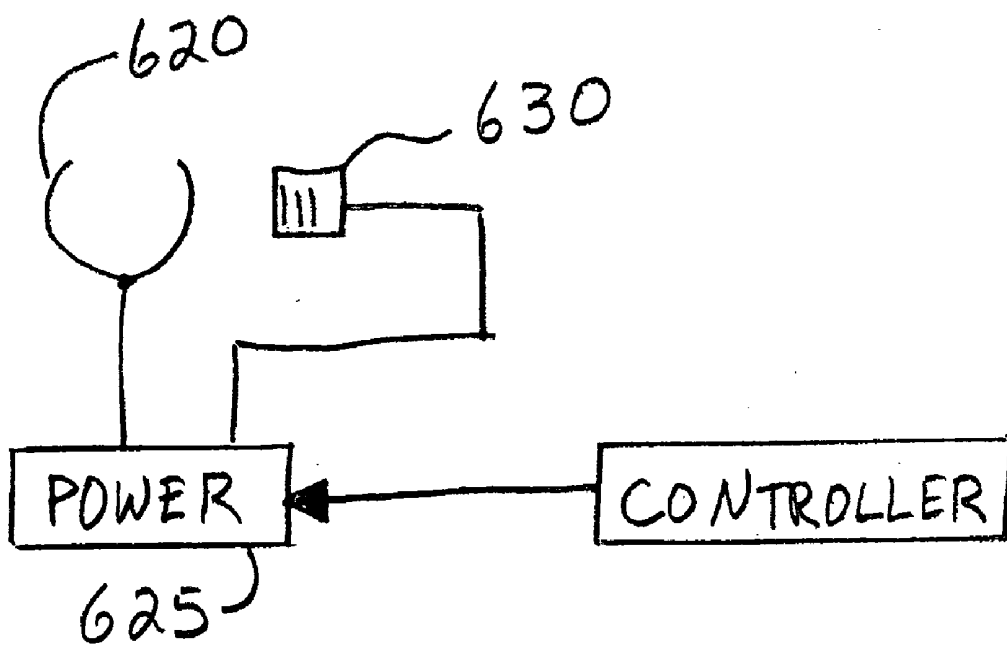

Fig. 47

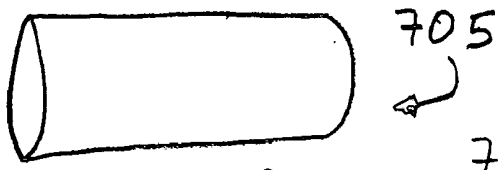

Fig. 48

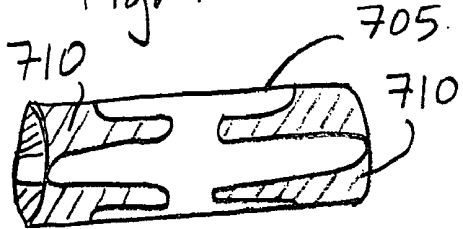

Fig. 49

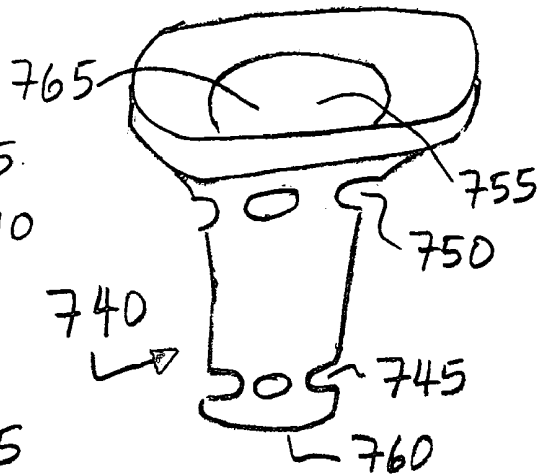

Fig. 53

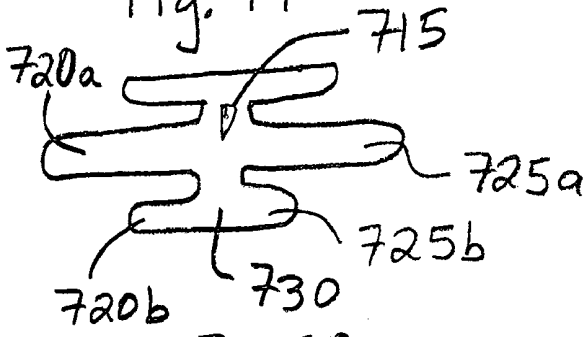

Fig. 50

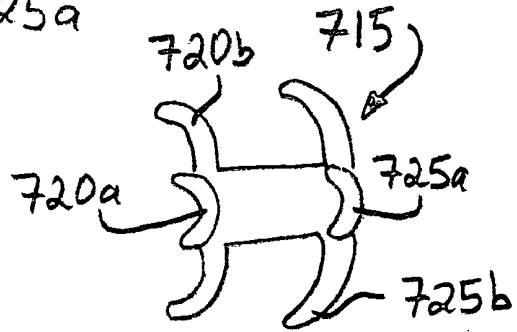

Fig. 52

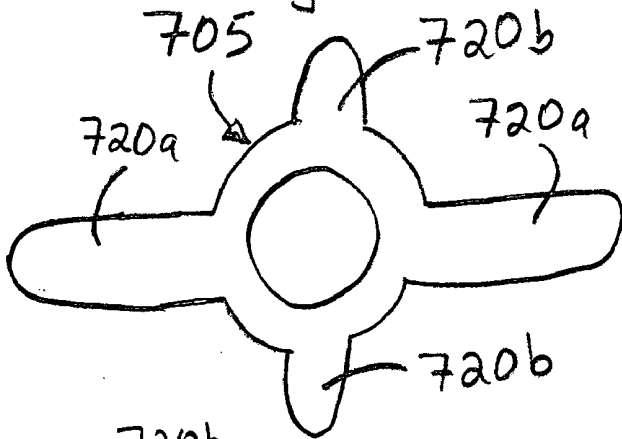

Fig. 51

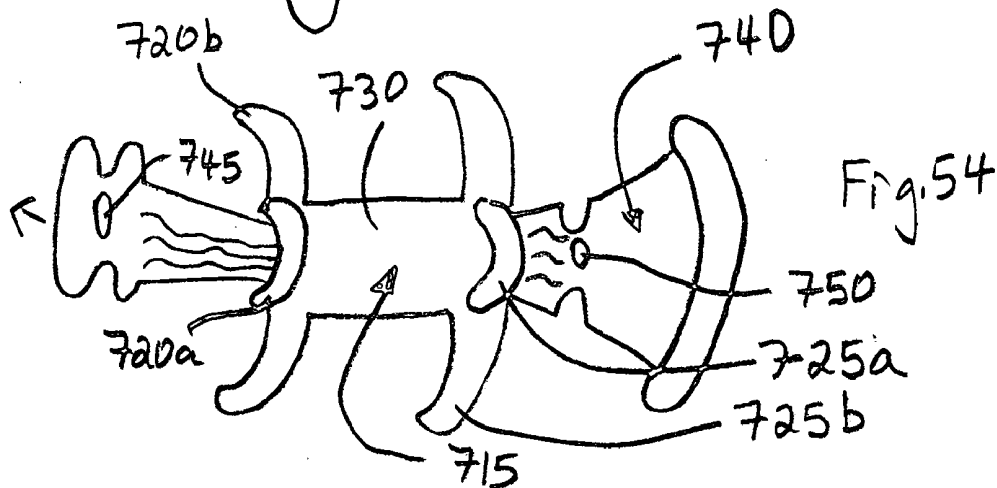

Fig. 54

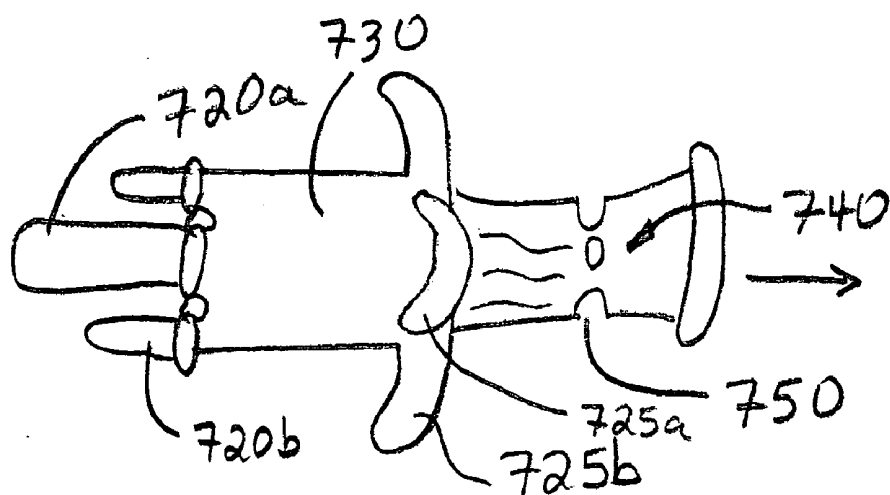

Fig. 55

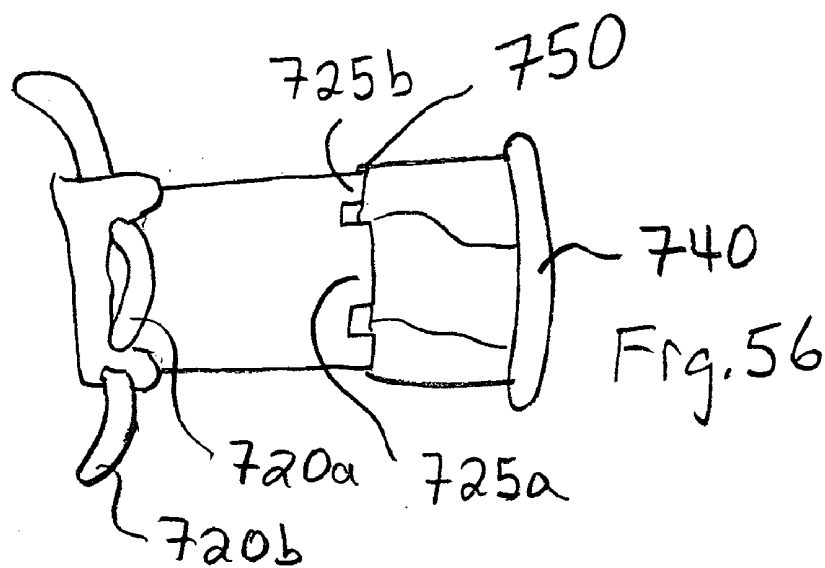

Fig. 56

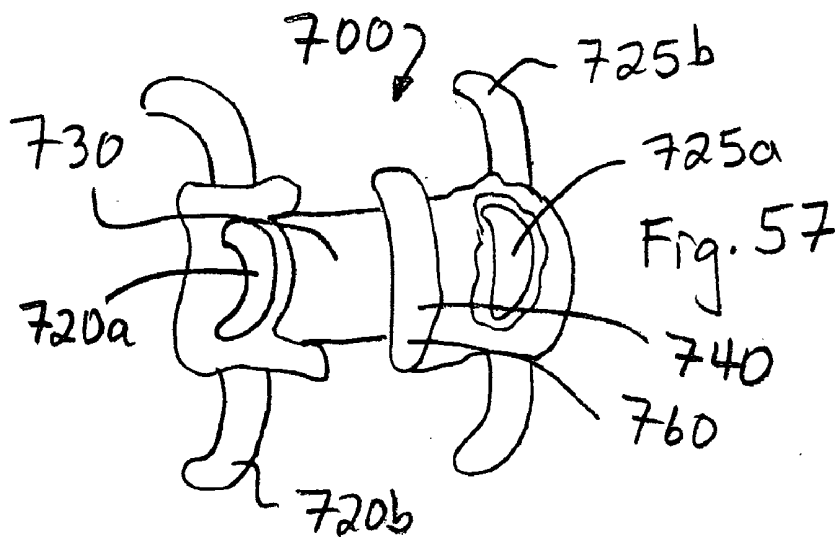
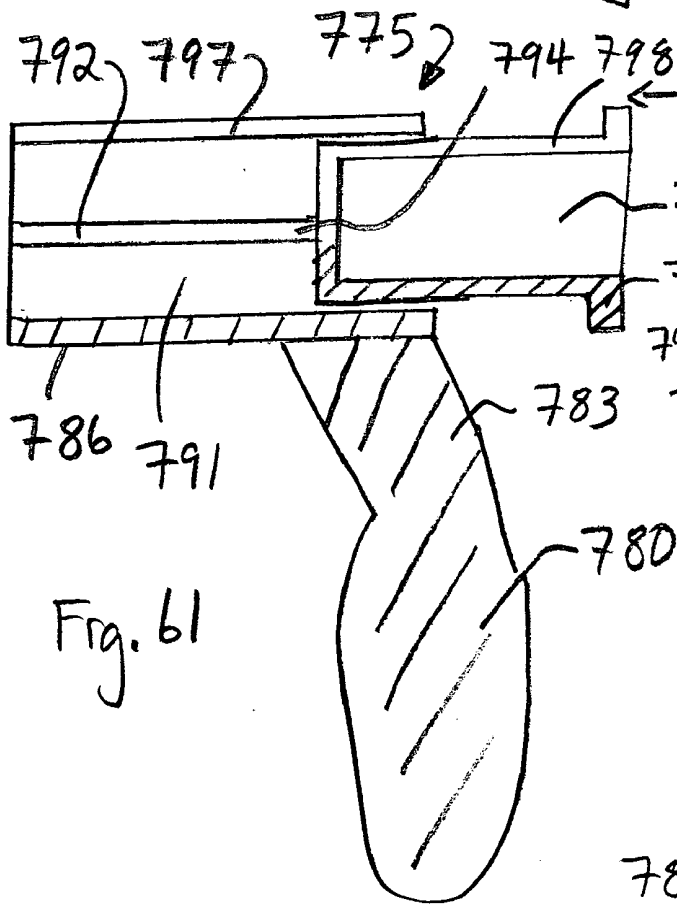
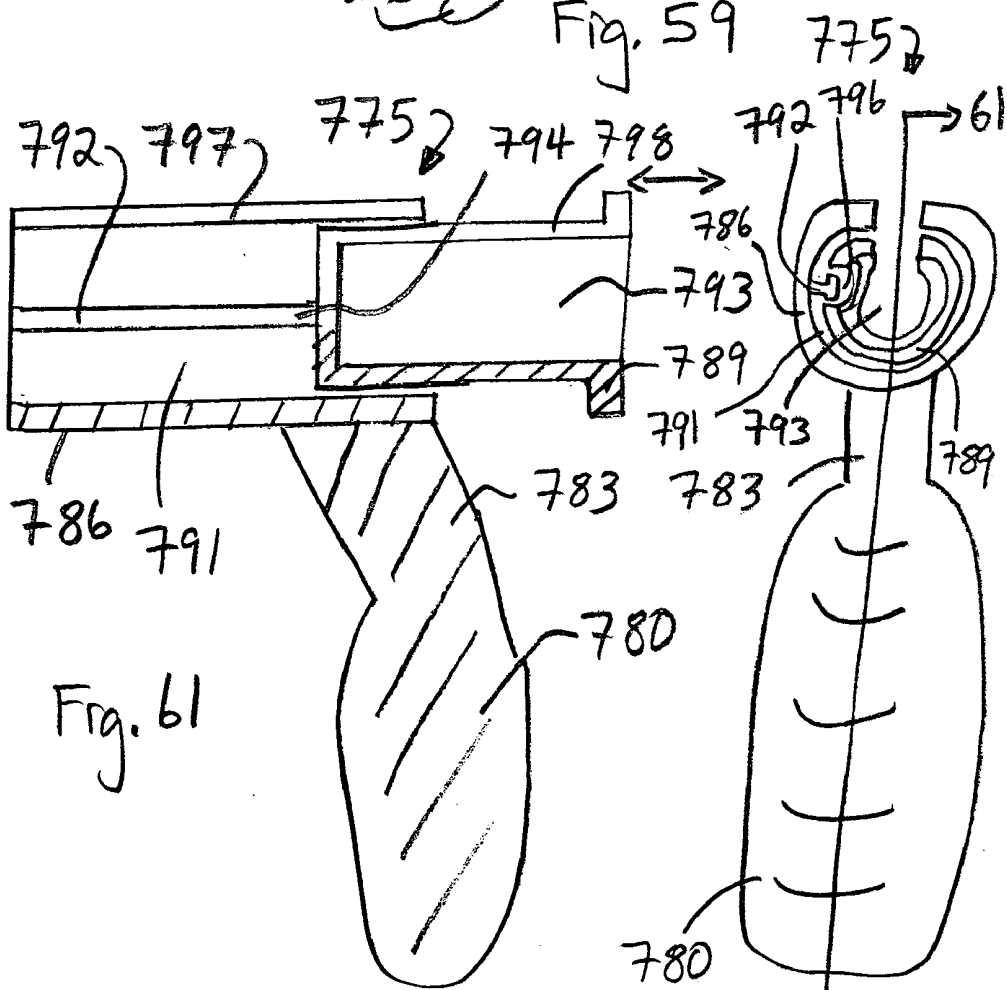
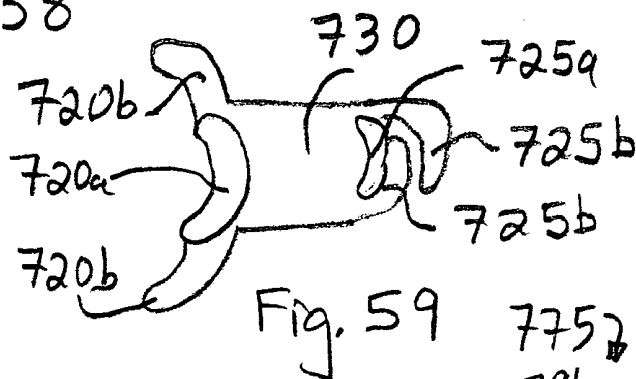
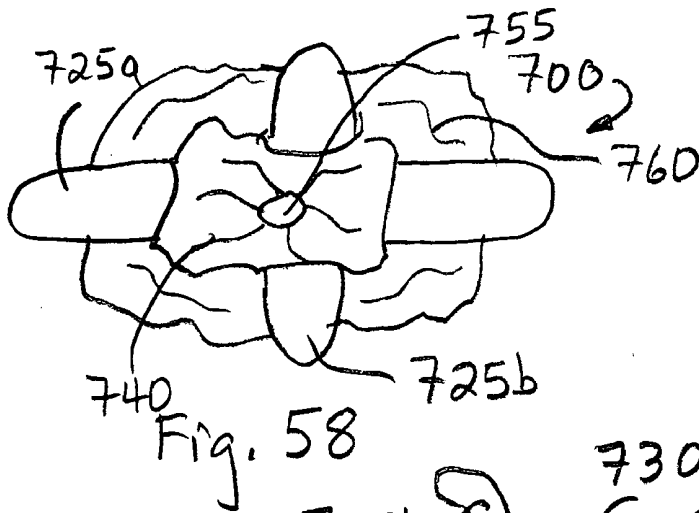

Fig. 57



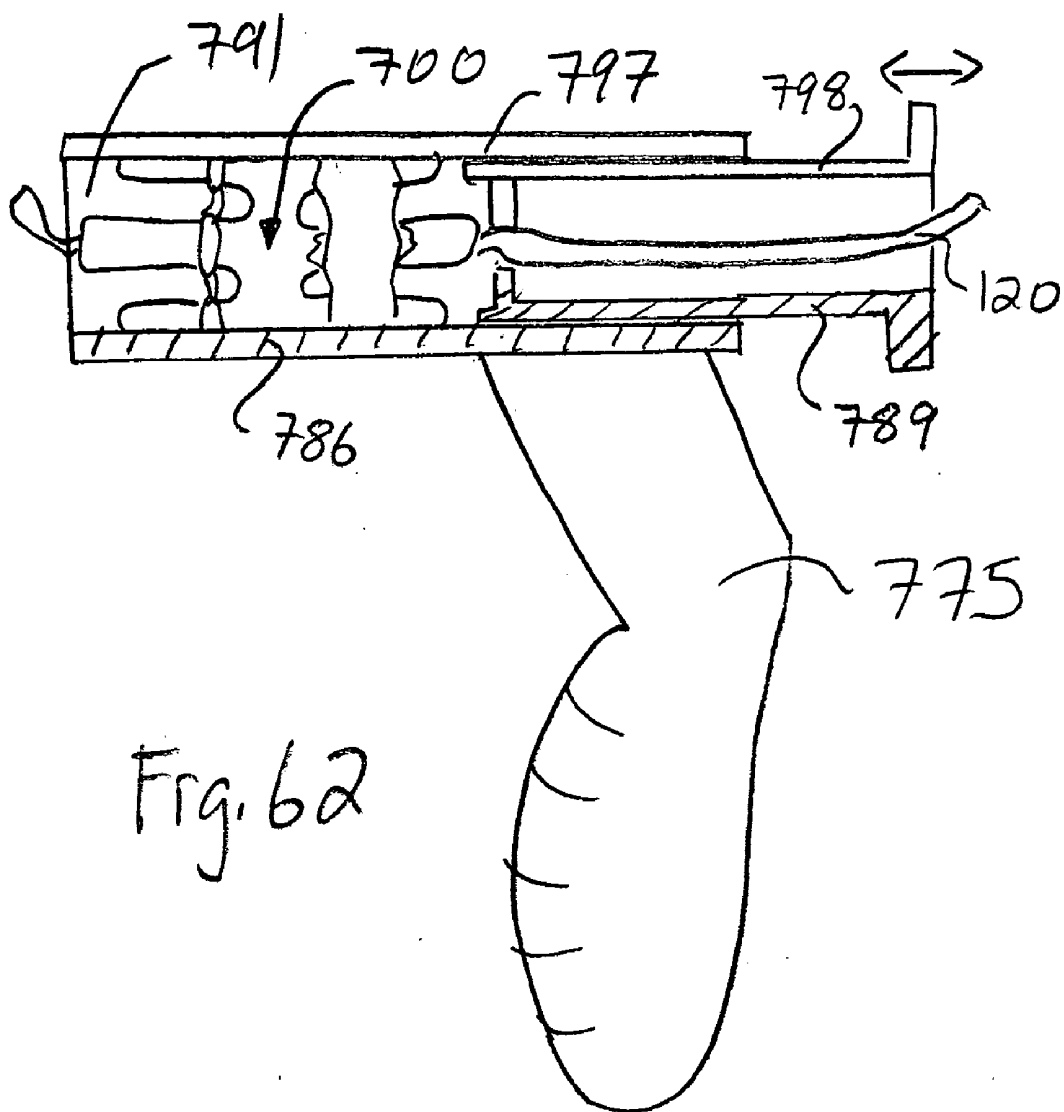

Fig. 62

## ARTERIOTOMY CLOSURE DEVICES AND TECHNIQUES

### RELATED APPLICATIONS

[0001] This application is a continuation of and claims the benefit of priority under Title 35, United States Code, §120 from U.S. Pat. No. 7,025,776 having Ser. No. 10/224,659 and titled Arteriotomy Closure Devices and Techniques and issuing on Apr. 11, 2006, which claims the benefit of U.S. patent application Ser. No. 10/127,714, filed Apr. 23, 2002 and titled Arteriotomy Closure Devices and Techniques, which claims the benefit of priority from U.S. Provisional Patent Application No. 60/286,269, filed Apr. 24, 2001 and titled Percutaneous Vessel Access Closure Device and Method; from U.S. Provisional Patent Application No. 60/300,892, filed Jun. 25, 2001 and titled Percutaneous Vessel Access Closure Device and Method, and from U.S. Provisional Patent Application No. 60/302,255, filed Jun. 28, 2001 and titled Percutaneous Vessel Access Closure Device and Method (Hemostatic Patch or Collar), each of which is incorporated herein in their entirety by reference.

### TECHNICAL FIELD

[0002] The field of the inventions generally relates to cardiovascular and arterial closure devices, and, more particularly, to arterial closure devices and techniques.

### BACKGROUND

[0003] In most cardiology and radiology procedures, a catheter is inserted into an artery, such as the femoral artery, through a vascular introducer. When the procedure is complete, the physician removes the catheter from the introducer and then removes the introducer from the arteriotomy into the vessel. The physician then must prevent or limit the amount of blood that leaks through the arteriotomy so that the patient can be discharged. Physicians currently use a number of methods to close the arteriotomy, such as localized compression, sutures, collagen plugs, and adhesives, gels, foams, and similar materials. To use localized compression, the physician presses down against the vessel to allow the arteriotomy to naturally clot. This method, however, can take half an hour or more, and requires the patient to remain immobilized for at least that period of time and be kept in the hospital for observation. There are potentials for clots at puncture site to be dislodged. Moreover, the amount of time necessary for the compression can be significantly increased depending upon how much heparin, glycoprotein IIb/IIIa antagonists, or other anti-clotting agents were used during the procedure. Sutures and collagen plugs may have procedure variability, may require time to close the vessel, may have negative cost factors, and may necessitate a separate deployment device. Adhesives, gels, and foams may have negative cost factors, may necessitate a possibly complicated deployment process, and may have procedure variability.

### SUMMARY

[0004] In one general aspect, an arterial closure device is deliverable over a tube for placement within and against an arteriotomy. The arterial closure device includes a first member forming an enlargement around the circumference of the arterial closure device and being configured to be received against an outer surface of a vessel; a connecting member having a smaller outer diameter than the first member, extend-

ing from the first member, and being configured to be positioned within an arteriotomy of a vessel; and a longitudinal channel configured to receive a tube and passing between the first member and the connecting member.

[0005] Embodiments of the arterial closure device may include one or more of the following features. For example, the connecting member may include slits. The connecting member may be expandable from a first narrow diameter to a second expanded diameter.

[0006] The arterial closure device may further include a second member extending from the connecting member, forming an enlargement around the circumference of the arterial closure device and being configured to be received against an inner surface of the vessel when the first member is received against the outer surface of the vessel. The arterial closure device may still further include an adhesive layer on at least one of the first member, the second member, and the connecting member. The first member may extend at an angle from the arterial closure device, the second member may extend at an angle from the arterial closure device, and the first member may be generally oriented in the direction of the second member.

[0007] The first member may include at least one superelastic/shape memory element configured to move between a first extended position and a second extended position and the second member may include at least one superelastic/shape memory element configured to move between a first extended position and a second extended position.

[0008] The arterial closure device may further include an adhesive layer on at least one of the first member and the connecting member. The arterial closure device may further include an adhesive within the longitudinal channel. The arterial closure device may further include longitudinal slots along the longitudinal channel.

[0009] The arterial closure device may further include an extending member extending from the first member in a generally opposite direction away from the connecting member and the longitudinal channel continues from the first member through the extending member. The extending member may include a closable opening of the longitudinal channel. The arterial closure device may further include a slot along at least a part of the length of the arterial closure device.

[0010] The arterial closure device may further include a deployment tool, the deployment tool including a handle, a contacting section, and an extension that extends between the handle and the contacting section. The contacting section is configured to mate with the arterial closure device to advance the arterial closure device over the tube and deploy the arterial closure device within the vessel.

[0011] In another general aspect, an arterial closure system includes an arterial closure device and a deployment tool. The arterial closure device includes a first member forming an enlargement around the circumference of the arterial closure device and being configured to be received against an outer surface of a vessel, a connecting member having a smaller outer diameter than the first member, extending from the first member, and being configured to be positioned within an arteriotomy of a vessel, and a longitudinal channel configured to receive a tube and passing between the first member and the connecting member. The deployment tool includes a handle, a contacting section, and an extension that extends between the handle and the contacting section, the contacting section being configured to mate with the arterial closure device to

advance the arterial closure device over the tube and deploy the arterial closure device within the vessel.

**[0012]** Embodiments of the arterial closure system may include any of the features described above or herein. For example, the arterial closure system may further include a second member extending from the connecting member, forming an enlargement around the circumference of the arterial closure device and being configured to be received against an inner surface of the vessel when the first member is received against the outer surface of the vessel. The first member may include at least one superelastic/shape memory element configured to move between a first extended position and a second extended position; and the second member may include at least one superelastic/shape memory element configured to move between a first extended position and a second extended position.

**[0013]** The arterial closure device may include a slot along at least a portion of the length of the arterial closure device and the contacting section of the deployment tool may include a longitudinal slot.

**[0014]** In another general aspect, a method of closing an opening in a vessel includes providing an arterial closure device that includes a first member forming an enlargement around the circumference of the arterial closure device and being configured to be received against an outer surface of a vessel, a connecting member having a smaller outer diameter than the first member, extending from the first member, and being configured to be positioned within an arteriotomy of a vessel, and a longitudinal channel configured to receive a tube and passing between the first member and the connecting member. The method further includes providing a deployment tool comprising a handle, a contacting section, and an extension that extends between the handle and the contacting section, the contacting section being configured to mate with the arterial closure device to advance the arterial closure device over the tube and deploy the arterial closure device within the vessel. The method still further includes slidably mounting the arterial closure device to a tube; inserting the tube through an opening into the vessel; using the deployment tool to advance and deploy the arterial closure device by advancing the arterial closure device along the tube until the connecting member is deployed within the vessel and the first member is received against the outer surface of the vessel; and removing the tube from the vessel and from the arterial closure device.

**[0015]** Embodiments of the method of closing an opening in a vessel may include any of the features described above or herein. For example the arterial closure device may further include a second member extending from the connecting member, forming an enlargement around the circumference of the arterial closure device and being configured to be received against an inner surface of the vessel when the first member is received against the outer surface of the vessel and an adhesive layer is positioned on at least one of the first member, the second member, and the connecting member, and deploying the arterial closure device further comprises positioning the second member against the inner surface of the vessel.

**[0016]** The arterial closure device, the arterial closure system, and the arterial closure method provides considerable advantages, as described herein. For example, the ACDs and methods described herein can provide: (1) the ability to deploy an ACD without the removal and re-insertion of a second device; (2) the ability to be used on most commercial

vascular introducers, catheters, tubes, etc.; (3) the ability to use tactile feedback to correctly and properly deploy an ACD without direct or indirect visual assistance; (4) the ability to use adhesives to secure the device to the vessel; (5) the ability to use adhesives to close off the device to prevent blood leaking or seepage; and (6) the ability to provide eluting therapeutic agents incorporated within or on the device. Moreover, the device, system and method are advantageously simple to use, inexpensive, and effective as a percutaneous vessel access closure device and method.

#### DESCRIPTION OF THE DRAWINGS

**[0017]** FIG. 1 is a side view of a arterial closure device positioned around a tubular section of a vascular introducer.

**[0018]** FIG. 2 is a side view of the arterial closure device of FIG. 1 advanced through a percutaneous opening by a deployment instrument.

**[0019]** FIG. 3 is a side view of the arterial closure device of FIG. 1 deployed through a vessel wall.

**[0020]** FIG. 4 is a cross-sectional side view of the arterial closure device of FIG. 1 deployed through a vessel wall.

**[0021]** FIG. 5 is a top view of the arterial closure device of FIG. 1.

**[0022]** FIGS. 6 and 7 are side and cross-sectional side views, respectively, of a second implementation of a arterial closure device deployed within an arteriotomy of a vessel wall.

**[0023]** FIG. 8 is a bottom end view of the arterial closure device of FIG. 6 showing the flared end opened.

**[0024]** FIG. 9 is a bottom end view of the arterial closure device of FIG. 6 showing the flared end closed.

**[0025]** FIG. 10 is a top end view of the arterial closure device of FIG. 6 showing the flared end partially closed.

**[0026]** FIG. 11 is a side view of the arterial closure device of FIG. 6 showing the flared end.

**[0027]** FIGS. 12 and 13 are a cross-sectional side view and a top view, respectively, of the arterial closure device of FIG. 1 having an adhesive on the inner diameter and tissue engagement areas.

**[0028]** FIGS. 14 and 15 are a cross-sectional side view and a top view, respectively, of the arterial closure device of FIG. 6 having an adhesive on the inner diameter and tissue engagement areas.

**[0029]** FIGS. 16 and 17 are a cross-sectional side view and a top view, respectively, of the arterial closure device of FIG. 1 having grooves on the inner diameter to form a thinned or weakened wall.

**[0030]** FIG. 18 is a side view of an angled arterial closure device.

**[0031]** FIG. 19 is a side view of an angled arterial closure device having a foldable extending member.

**[0032]** FIG. 20 is a side view of a deployment tool.

**[0033]** FIG. 21 is a side view of the deployment tool of FIG. 20 used to deploy a arterial closure device.

**[0034]** FIG. 22 is an end view of the deployment tool FIG. 20.

**[0035]** FIG. 23 is a side view of the deployment tool of FIG. 20 having an extended contacting member.

**[0036]** FIG. 24 is a side view of the deployment tool of FIG. 23 used to deploy a arterial closure device.

**[0037]** FIG. 25 is an end view of the deployment tool FIG. 23

[0038] FIG. 26 is a cross-sectional side view of an arterial closure device having angled closure edges for compressing a vessel wall.

[0039] FIG. 27 is a top view of the arterial closure device of FIG. 26.

[0040] FIG. 28 is a side view of the arterial closure device of FIG. 26 being advanced through the skin into a vessel with the closure edges deflected.

[0041] FIG. 29 is a side view of the arterial closure device of FIG. 26 deployed and secured onto vessel wall with the closure edges occluding the arteriotomy.

[0042] FIG. 30 is a side view of an arterial closure device.

[0043] FIG. 31 is an end view of the arterial closure device of FIG. 30.

[0044] FIG. 32 is a perspective side view of a vascular connector having a closable end.

[0045] FIG. 33 is an end view of the arterial closure device of FIG. 32.

[0046] FIG. 34 is a side view of a liner having a longitudinal slot for an arterial closure device.

[0047] FIG. 35 is an end view of the liner of FIG. 34.

[0048] FIG. 36 is a side view of a liner having a radial slot.

[0049] FIG. 37 is an end view of the liner of FIG. 36.

[0050] FIG. 38 is a side view of a plug-style arterial closure device that includes an adhesive layer on the vessel contact areas.

[0051] FIG. 39 is a side view of a plug style arterial closure device that has limited vessel protrusion and includes an adhesive on the vessel contacting areas.

[0052] FIGS. 40 and 41 are side views of the plug style arterial closure device of FIG. 39 being deployed and deployed within a vessel.

[0053] FIG. 42 is an end view showing the distal end of the introducer inside a vessel.

[0054] FIGS. 43 and 44 are end views showing a flared arterial closure device deployed along the introducer.

[0055] FIG. 45 is an end view showing the flared arterial closure device of FIG. 43 deployed against the vessel to close the arteriotomy.

[0056] FIGS. 46 and 47 are electrical schematics for a direct resistive element heating circuit and an ohmic tissue heating circuit.

[0057] FIG. 48 is a perspective view of a tube used to fabricate an arterial closure device.

[0058] FIG. 49 is a perspective view of the tube of FIG. 48 showing material being removed.

[0059] FIG. 50 is a side view of the tube of FIG. 48 with the material removed.

[0060] FIG. 51 is a top view of the curved configuration.

[0061] FIG. 52 is a side view of the configuration of FIG. 51.

[0062] FIG. 53 is a perspective view of a fabric covering.

[0063] FIGS. 54-58 are side views showing the fabric covering of FIG. 53 being mounted within the curved configuration of FIG. 51 to form an arterial closure device.

[0064] FIG. 59 is a side view of a configuration having side arms that fold over each other.

[0065] FIGS. 60 and 61 are front and cross-sectional side views of a deployment tool for deploying the arterial closure device.

[0066] FIG. 62 is a cross-sectional side view of the deployment tool of FIG. 60 having the arterial closure device within.

#### DETAILED DESCRIPTION

[0067] Referring to FIGS. 1-3, a vascular closure system 100 generally includes two components: an arterial closure device ("ACD") 105 and a deployment instrument 110. The ACD 105 is slidably mounted to a vascular introducer 115 or other tubular device, such as a catheter, advanced over a tube section 120 of the introducer 115 using the deployment instrument 110, passed through a percutaneous opening 125, and placed through an arteriotomy 130 in a vessel wall 133 into a blood vessel 135. The deployment tool 110 and the introducer 115 then are removed from the blood vessel 135 and out of the percutaneous opening 125.

[0068] Referring to FIGS. 4 and 5, the ACD 105 is generally compliant, tubular, and includes a first member 140, a second member 145, a connecting member 150 between the first member and the second member, and an optional extending member 155 that extends from the second member. A longitudinal channel 160 passes between a first opening 165 in the extending member (or second member if the extending member is not present) and a second opening 170 in the first member 140.

[0069] The ACD 105 is formed of a tubular structure of sufficient length and thickness (e.g., a single wall thickness of between 0.005" and 0.05", and more particularly between 0.01" and 0.02") that can be advanced over the introducer 115, and through the puncture site 125. The ACD 105 has sufficient rigidity to be advanced through the puncture site 125 yet is compliant enough to be compressed onto itself by the natural elasticity of the vessel wall 133 after the introducer 115 is removed. Moreover, the connecting member 150 can be configured to have a natural elasticity such that when it is no longer mounted over the introducer tube 120, it will return to its original smaller diameter state. The ACD 105 may include, for example, longitudinal sections of the tube where the wall thickness is thinner (e.g., connecting member 150) thereby creating creases or weakened areas that receive the vessel wall 133. The creases would reduce the amount of compressive force required to collapse the tube onto itself. A design allowing tactile feedback may be used to determine the proper insertion position (depth). The tactile feedback could be accomplished by the ACD 105 having one or more rings of increased wall thickness, an "hour glass" geometry, a thin, narrow, then wide geometry, combination, or other means to provide an abrupt change in the advancing force resistance during deployment. The ACD 105 may be manufactured in many different French sizes, to match the outer diameter of any commercial vascular introducers 115.

[0070] The ACD 105 is placed around the outside of any commercially available introducer 115, or other device that is inserted into the cardiovascular system (e.g., catheter, etc.), and positioned adjacent to the proximal end of the introducer (i.e., near the valve or luer fitting of the introducer). The introducer 115 then is inserted into the vasculature using standard techniques. Prior to removing the introducer 115, the tubular ACD 105 is advanced to the skin, for example, by the physician manually advancing the ACD along the tube 120. The deployment instrument 110 then is positioned against or clipped onto the tube 120, advanced to be in contact with the proximal end (i.e., second member 145) of the ACD 105, and advanced through the skin such that at least the distal most portion (e.g., first member 140) of the ACD is

inside the vessel **135**. The ACD **105** is prevented from deforming or collapsing during insertion by the rigidity of the tube **120**. The tube **120** also acts as a guide to position the ACD **105** through the puncture site **125** during its advancement and deployment. When the introducer **115** is removed, the deployment instrument **110** is held in position and still in contact with the ACD **105** preventing the ACD from coming out of the vessel **135** along with the introducer. Once the introducer **115** is completely removed, the ACD **105** is compressed together due to the elastic recovery of the vessel wall **133**, achieving hemostasis and effectively sealing the arteriotomy **150** and puncture site **125**.

**[0071]** The ACD **105** can be partially or completely fabricated from a biocompatible material, such as expanded polytetrafluoroethylene (ePTFE), polyester, polyurethane, silicone, Dacron, urethane, and/or a composite or combination of these or other suitable materials. The ACD **105** also can be partially or completely fabricated from a biodegradable/bioabsorbable material, including modified cellulose, collagen, fibrin, fibrinogen, elastin or other connective proteins or natural materials, polymers or copolymers such as polylactide [poly-L-lactide (PLLA), poly-D-lactide (PDLA)], polyglycolide, polydioxanone, polycaprolactone, polygluconate, polylactic acid (PLA), polylactic acid-polyethylene oxide copolymers, poly(hydroxybutyrate), poly(anhydride), polyphosphoester, poly(amino acids), poly(alpha-hydroxy acid) or related copolymers of these materials as well as composites and combinations thereof and combinations of other biodegradable/bioabsorbable materials.

**[0072]** The ACD **105** also can be partially or completely fabricated from materials that swell, or expand when they are exposed to a fluid, such as blood, or another fluid, for example, that can be added by the physician to cause the material to swell. These materials include hydrophilic gels (hydrogels), regenerated cellulose, polyethylene vinyl acetate (PEVA), as well as composites and combinations thereof and combinations of other biocompatible swellable or expandable materials.

**[0073]** The ACD **105** can be made using several methods and processes including extrusion, molding (i.e., injection molding or other known molding techniques), casting, dip coating, spraying, adhesive bonding, ultra-sonic welding, composite fabrication techniques, and combinations of these and/or other similar methods and processes.

**[0074]** The ACD **105** also can have a biocompatible contact adhesive or other material within the longitudinal channel **160** so that when the longitudinal channel is compressed within the arteriotomy **130**, the adhesive bonds the inside surfaces of the longitudinal channel together. This assists or expedites the sealing of the arteriotomy. Additionally, bonding materials can be used on the outside of the ACD **105**, for example, on the outer surface of the first member **140**, the second member **145**, the connecting member **150**, and or the optional extending member **155**. In particular, the bonding material is especially useful where the ACD contacts the vessel wall **133** defining the arteriotomy **130**.

**[0075]** The biocompatible contact adhesive/adhesive/bonding compounds/solutions could be added during the manufacturing process, just prior to deployment, or after the device has been deployed. The bonding materials could be in the form of a liquid, semi solid, or solid. Suitable bonding materials include gels, foams and microporous mesh. Suitable adhesives include acrylates, cyanoacrylates, epoxies, fibrin-based adhesives, other biological based adhesives, UV light

and/or heat activated or other specialized adhesives. The adhesive could bond on initial contact, or longer, to allow repositioning if desired. The preferred adhesive may be a crystalline polymer that changes from a non-tacky crystalline state to an adhesive gel state when the temperature is raised from room temperature to body temperature. Such material is available under the trade name Intillemer™ adhesive, available from Landec Corp. as well as composites and combinations thereof and combinations of other materials. Suppliers of biocompatible adhesives include, but are not limited to, Plasto (Dijon, France), Haemacure (Montreal, Canada), Cohesion (Palo Alto, Calif.), Cryolife (Kennesaw, Ga.), TissueLink (Dover, N.H.), and others. To increase the work time of the adhesive or allow repositioning of the vascular coupler after it has been deployed, the adhesive can be blended with a material, such as a starch or other material, that retards or delays bonding to allow repositioning of the coupler after it has been deployed. A degradable coating can be placed over the adhesive coating so that it degrades and exposes the adhesive. Other adhesives are understood to include composites-based adherents and combinations of the above materials and other suitable materials as are known in the art.

**[0076]** To improve later detection of the ACD **105**, it can be fabricated from materials that include one or more radiopaque materials, such as barium sulfate, bismuth trioxide, or other any other radiopaque material. The radiopaque material is added to the materials from which the ACD **105** is fabricated or to the bonding materials that are placed in, on, or around the ACD.

**[0077]** Referring to FIGS. 6-11, a second implementation of an arterial closure device is shown as an arterial closure device ("ACD") **200**. The ACD **200** includes a first member **205**, a second member **210**, and an optional extending member **215** that extends from the second member. A longitudinal channel **220** passes between a first opening **225** in the extending member (or second member if the extending member is not present) and a second opening **230** in the first member **205**. The ACD **200** is implanted within an arteriotomy **130** in a manner similar to the implantation of the ACD **105**. However, the ACD **200** does not include a member that is substantially in contact with the inner wall of the vessel **135**. Instead, the ACD has a flare, or two or more short slits **235** in the side wall of the first member **205**. The flare or slits **235** are designed to open or flare around the catheter or introducer **120** when advanced to the top of the vessel puncture site (FIG. 8). The materials from which the ACD **200** or the second member **205** are fabricated may be a very elastic material such that when around the introducer it expands and when advanced beyond the end of the introducer, it contracts such that the individual flares pinch or otherwise catch the edges of the arteriotomy or punctured vessel and pull them together while contracting (FIG. 9). This action is intended to close the arteriotomy **130** and create hemostasis. The inside of the flared section **235** of the ACD **200** may have a biocompatible contact adhesive or other bonding material, as described above, that further secures the ACD within the arteriotomy and to the vessel **135**, and, in particular the second member **210** to the top or outer surface of the vessel.

**[0078]** As indicated above, the adhesive or bonding materials can be implemented on any of the above ACDs. For example, referring to FIGS. 12 and 13, the ACD **105** has an adhesive or bonding material **270** on the inner diameter and tissue engagement areas. Similarly, referring to FIGS. 14 and 15, the ACD **200** has the adhesive or bonding material **270** on

the inner diameter and tissue engagement areas. In this manner, adhesive 270 will close the respective longitudinal channel 160, 200 of the ACD 105, 200 to reduce or eliminate seepage blood. Moreover, the adhesive 270 around the tissue contacting areas will bond the ACD to the vessel wall to reduce or eliminate seepage of blood through those regions.

[0079] Referring to FIGS. 16 and 17, the ACD 105 can have the inner diameter of the longitudinal channel 160 modified to include ridges 280 and channels 285 that weaken or thin the wall section of the ACD. In this manner, the inner diameter of the longitudinal channel 160 can be expanded or reduced depending upon the circumferential pressure exerted against the ACD. For example, when passing the introducer through the longitudinal channel the inner diameter will be expanded. When the introducer is subsequently removed, the inner diameter is reduced because of the natural elastic recoil properties of the ACD. In this manner, the seepage of blood through the longitudinal channel is reduced or eliminated. Moreover, the surfaces of the inner diameter of the longitudinal channel can be coated with an adhesive, as described above, to further ensure that the inner diameter is closed.

[0080] The ACDs described herein also can include one or more therapeutic agents that affect healing at the site where the device is deployed. The agent(s) can be incorporated into the structure forming the device and/or incorporated into a coating. Such therapeutic agents may include, but are not limited to, antithrombotics (such as anticoagulants), antimittogens, antimittotoxins, antisense oligonucleotides, gene therapy solutions, nitric oxide, and growth factors and inhibitors. Direct thrombin inhibitors that may be beneficial include Hirudin, Hirugen, Hirulog, PPACK (D-phenylalanyl-L-propyl-L-arginine chloromethyl ketone), Argatran, and D-FPRCH.sub.2 Cl (D-phenylalanyl-L-propyl-L-arginyl chloromethyl ketone); indirect thrombin inhibitors include Heparin and Warfarin (coumadin). Alternatively, a clot promoter may be used, such as protamine sulphate or calcium hydroxide. Additional therapeutic materials include, aspirin, dexamethasone, dexamethasone phosphate, streptokinase, tocopherol, TPA, urokinase, paclitaxel (Taxol), actinomycin, rapamycin, or other. Sirolimus, or other antibiotics may also be used. The therapeutic compounds/solutions may be blended with the device base materials during fabrication, applied just prior to deployment, or after the device has been deployed. Additionally, the therapeutic materials may be located on, through, inside, or combination of the device in holes, grooves, slots or other indentation to allow elution of the therapeutic compound(s). Post device fabrication coating methods include, but are not limited to, dipping, spraying, brushing, submerging the devices into a beaker containing a therapeutic solution while inside a vacuum chamber to permeate the device material, etc.

[0081] The geometry of the ACDs described herein is shown for illustration purposes as being generally round. However, they can be of any other geometry, such as oval, elliptical, rectangular, square, ridged, or a combination of shapes. The ACD has been illustrated as forming a generally perpendicular angle with the vessel wall once deployed. Nonetheless, the inventors intend the configuration to be at any suitable angle, such as between 30° and 60°, or, for example, 45° or as otherwise desired. A range of angles of the ACD can be available and the physician can choose the appropriate ACD based on the angle at which the introducer is introduced into the vessel. For example, referring to FIG. 18, a ACD 290 is formed to have the extending member 155

extending at an angle of approximately 45° from the second member 145. In addition, the first member 140 and the second member 145 are longitudinally offset. This configuration is designed to cause the extending member 155 to follow the path created by the introducer. Referring also to FIG. 19, the ACD has a second member 292, a foldable extending member 294, and a groove 296 positioned between the second member 292 and the folding extending member 294. In this manner, the extending member 294 can be folded or bent over to be less obtrusive and to close off the flow of blood through the ACD.

[0082] Referring to FIGS. 20-22, a deployment tool 300 is designed to engage or otherwise contact the proximal edge, or other edge, of the ACD. The tool 300 is generally handheld and includes a handle 305, an extension 310, and a contacting section 315 that clips onto, or otherwise contacts the outside of the introducer and mates with the ACD. The contacting section 315 has sufficient length to advance the ACD through the tissue to the desired position on the vessel. The handle 305 or grasping section can be, for example, round, rectangular, elliptical, or a combination of shapes or other shape that fit comfortably in the hand. The contacting section 315 can have a cross-sectional geometry of a partially open tube having more than 50% diameter coverage, so that it can clip onto, and slide over the outer diameter of the introducer.

[0083] Referring also to FIGS. 23-35, the deployment tool can include an additional extension 320 that is configured to fit around the extending member 155 and mate with the second member 145. The extension 320 can be attached to the introducer after the introducer is positioned within the artery.

[0084] The deployment tool 300 can be made partially or completely from several different polymer materials including polycarbonate, nylon, polyethylene, polytetrafluoroethylene (PTFE), fluoroethylene-propylene (FEP) or polyfluoroacrylate (PFA), polyester ether ketone (PEEK), polyamide, polyimide, polyethyleneterephthalate (PET), combination or other material able to withstand sterilization processing. The tool can also be made partially or completely from several different types of metals including stainless steel; spring metal alloys such as Elgiloy™, Inconel™; superelastic/shape memory alloys such as Nitinol (NiTi) as well as composites and combinations thereof and combinations of other materials.

[0085] The deployment tool 300 can be made using several methods and processes including extrusion, molding (injection and other), casting, adhesive bonding, ultrasonic welding as well as combinations thereof and combinations of other methods and processes.

[0086] Modifications of the deployment tool 300 are possible. For example, the proximal edge of the ACD (i.e., of the extending member 155 or the second member 145) and the distal edge or other portion of the advancement tool 300 may have interlocking geometries to aid and/or control the position of the ACD during advancement along the introducer. The engagement/contact section 315, 320 of the tool 300 may have a cross-sectional geometry of a complete circle that is designed to split away from the introducer once the ACD has been advanced and deployed. Splitting can be accomplished by having weakened areas in the wall of the tubing, such as linear perforations, or linear scores. This version would require that the deployment tool be back loaded onto the introducer before the ACD is placed onto the introducer and prior to insertion into the vessel.

[0087] The inside, concave section of the contact section 315, 320 may be coated with a hydrophilic or other lubricious material to reduce the friction during advancement and deployment of the ACD. In addition to the deployment tool 300 contacting the proximal edge of the ACD, the contacting section 315, 320 of the tool can be lengthened and designed to further attach to and compress the distal edge of the ACD, thereby providing additional support during insertion and deployment into the vessel.

[0088] Referring to FIGS. 26-29, a ACD 350 includes a first angled closure edge 355, a second angled closure edge 360, an extending member 365, and a connection member 370 between the first and second angled closure members. The first angled closure edge 355 and the second angled closure edge are generally directed at each other such that they define a narrow opening 375 through which the vessel wall 133 is received. The ACD 350 is deployed over the introducer tube section 120 using, for example, the deployment tool 300. As illustrated in FIG. 28, the second angled closure edge 360 is deflected away from the first angled closure edge 355. The deflection can be caused, for example, by the contacting section 320 surrounding the second angled closure edge 360. In this manner, when the deployment tool 300 is removed, the second angled closure edge 360 deflects back to compress the vessel wall 133 between the angled closure edges 355, 360. The angled closure edges 355 and 360 are formed, for example, from a flexible member, such as a polymer, superelastic/shape memory material, or a combination of the two. For example, the superelastic/shape memory member can be coated with a polymer.

[0089] Referring to FIGS. 30 and 31, a ACD 400 includes a threaded section 405 and an extending section 410. The threaded section 405 includes threads 415 mounted on and between a first member 420 and a second member 425. The extending section 410 includes a longitudinal channel 430 that includes a distal shaped channel 435. A deployment tool having a mating shaped distal end is inserted into the longitudinal channel 430 such that it mates with the distal shaped channel 435. By rotating the deployment tool, the ACD can be threadably inserted into the arteriotomy.

[0090] In general, the distal edge of the ACD 400 is designed to engage the opening of the arteriotomy or puncture site and protrude to a specific depth based on how many times the ACD was advanced, twisted or turned. The ACD 400 may have a stop 437 to limit how far the device protrudes into the vessel. The same "screw" type distal edge could be used on a hemostatic plug, made from a solid piece of material, rather than a tube structure. A deployment tool would be needed that has, for example, a grasping distal end for insertion into the vessel.

[0091] The ACD 400 can be modified to include a longitudinal channel that pass through the entire length of the device and deployed over a introducer. In this case, the deployment tool and the proximal edge of the ACD would have a mating geometry such that the deployment tool is rotated to threadably insert the ACD through the arteriotomy.

[0092] Referring to FIGS. 32 and 33, a ACD 450 includes a tissue contacting member 455 and an extending member 460. A longitudinal channel 463 passes through the ACD. The extending member 460 includes a longitudinal slot 465 and a circumferential channel 470 in which a contracting member 475 is received. The contracting member 475 tends to close the longitudinal channel 463 unless kept open, for example, by an introducer 115 within the channel. In this manner, when

the ACD 450 is deployed within the arteriotomy and the introducer is removed, the longitudinal channel is closed, which prevents or limits blood flow or seepage through the channel. The ACD can be formed from any of the materials described above. For example, the ACD can be formed from a polymer and the extending member can be formed from a flexible material such as a polyurethane/Dacron composite that easily collapses as a consequence of contraction property of the contracting member 475.

[0093] Referring to FIGS. 34 and 35, a ACD inner liner 480 is formed as a simple slotted tube 485 that includes a slot 490 along its length that functions a means for side access onto the introducer, after the introducer has been inserted into the vessel. The slot 490 can be formed as a longitudinal or radial slit, illustrated below. The ACD inner liner can be opened sufficiently to attach onto the introducer from the side. Any configuration of the ACDs described herein is built around the ACD liner 480 with a slot formed within the ACD. The tube 485 optionally can extend from the ACD and then be clamped at the proximal end once the ACD liner 480 and ACD are deployed.

[0094] Referring to FIGS. 36 and 37, a ACD liner 500 includes a tube 505 that includes a radial slot 510 along an extending member 515 and through a first member 520 and a second member 525. The ACD inner liner 500 is sufficiently openable to be threaded onto the introducer from its side. Any configuration of the ACDs described herein can be built around the ACD liner 500 with a slot formed within the ACD. The tube 505 optionally can extend from the ACD and then be clamped at the proximal end once the ACD liner 500 and ACD are deployed.

[0095] Referring to FIGS. 38-41, a plug style ACD 550 that is similar to ACD 105 includes a channel 555 into which a deployment tool 552 is inserted to deploy the ACD through an arteriotomy to close the arteriotomy. The ACD includes an adhesive layer 560 for bonding to the tissue. The ACD 550 differs from the ACD 105 in that the channel 555 does not extend the entire length of the ACD. A ACD 570 (FIG. 39) is similar to the ACD 550 except that it has limited vessel protrusion, similar to the ACD 200 above. The ACD 550, 570 is placed into the arteriotomy and held briefly for an adhesive bond to form. The deployment device 552 then can be removed.

[0096] The distal end of the deployment tool 552 also can have a grasping feature to grasp the proximal end of the plug ACD during deployment and to release after the plug ACD has been seated in or is on the vessel, and able to release when the tool is being withdrawn.

[0097] Referring to FIGS. 42-45, a ACD can have a distal end geometry, which once positioned at the puncture site, is designed to compress the vessel wall for increased securement and sealing. For example, a ACD 600 may have a flare 605, or two or more longitudinal slits in the side of the tube, that are designed to open, or flare apart when advanced and in contact with the top of the vessel puncture site (i.e., arteriotomy). The ACD 600 can be made from a very elastic material and/or a superelastic/shape memory material such that when the introducer is removed, the flares or slits will pinch, or otherwise bring the edges of the punctured vessel together, effectively creating hemostasis. The inside of the flared section of the closure device could have biocompatible contact adhesive, other bonding material, and/or small barbs or protrusions that may assist in securing the device to the top of the vessel wall.

[0098] Referring to FIGS. 46 and 47, heat can be used to assist with, or as an adjunct to, the process by recovering the ACD, activating (e.g., causing to flow, etc.) a hemostatic material to the puncture site that assists in sealing (e.g., through vessel contraction including the denaturing and reformation of collagen at the site) or accelerate healing, or a combination of these or other beneficial effects. Direct resistive element heating (FIG. 46) or ohmic tissue heating (FIG. 47) can be utilized. Biocompatible electrode materials (e.g., gold, platinum, and other suitable materials) can be mixed with the base material of the ACD as a powder during manufacturing, or as a wire, strip, or other geometry, added onto any surface of the device, and connected to a suitable (i.e., electrical and biocompatible) conductor. For ohmic tissue heating, one conductor 620 is connected to an RF power source. Another conductor is connected to a ground pad 630 placed on the patient's body, and also connected to the power source. For direct resistive element heating, both conductors from the power source 625 are connected to an electrode 635. Once the sealing of the puncture site has occurred, a twisting, cutting, or other manipulative action removes the conductor previously attached to the closure device. Alternatively, a special tip is placed over a standard electro surgical tool (e.g., Bovie) to insert through the skin and make contact with the closure device, tissue or both.

[0099] Alternative versions of the closure device may utilize an electrode that is formed by ion deposition, sputter coating, spraying, dip coating, adhesive, combination or other method or design.

[0100] Referring to FIGS. 48-58, a superelastic/shape memory ACD 700 is made from a superelastic/shape memory sheet or tube 705. The sheet or tube 705 is etched, cut, or otherwise machined to remove material 710 (FIG. 49) to leave a starting configuration 715 (FIG. 50). The method of removing the material may be, for example, photo-etching and/or laser or chemical cutting. The starting configuration includes first extending members 720, second extending members 725, and a connecting member 730 between the first and second extending members. The first and second extending members 720 and 725 then are bent and curved (FIGS. 51 and 52). The first and second extending members are curved to mate with the inner and outer surface, respectively, of a vessel. For example, longer first and second extending members 720a and 725a are bent to be generally perpendicular to the connecting member 730 and have a curvature that is similar to that of the length dimension of a vessel wall. The shorter first and second extending members 720b and 725b are bent to have a radius of curvature that is similar to that of the radius of curvature of the circumference of a vessel wall. The shapes of the first and second extending members 720, 725 are set using known techniques of imparting shapes in superelastic/shape memory materials, as described in further detail below.

[0101] A fabric covering 740 (FIG. 53), such as Dacron, then is mounted to the curved configuration 715. The covering 740 includes distal side openings 745 and proximal side openings 750. A longitudinal channel 755 passes between a distal opening 760 and a proximal opening 765. The covering 740 is pulled distal end through the curved configuration 715 and the extending members 720 are straightened from their retracted state and passed through the distal side openings 745 (FIG. 54). The covering 740 then is pulled back such that the distal side openings 745 are tight against the first extending members 720 (FIG. 55). The first extending members 720

then are allowed to expand back to their retracted state. The second extending members 725 then are straightened from their retracted state and passed through the proximal side openings 750 (FIG. 56). The second extending members 725 then are allowed to expand back to their retracted state, thereby trapping a proximal end 760 of the covering against the connecting member 730 between the first and second extending members 720, 725 (FIGS. 57 and 58). The longitudinal channel 755 passes through the covering 740 and the shaped configuration 715.

[0102] Referring to FIG. 59, the second extending members 725b can be configured to curve back over and under the opposite second extending member 725b. Thus, instead of curving against the outer circumference of the vessel in which the device is implanted, the second extending members 725b function to close the longitudinal channel 755 when they are in their retracted position. The covering 740 is mounted to the curved configuration 715 as described above. The second extending members 725b are kept in a straightened position because of the introducer or catheter that passes through the longitudinal channel 755. When the introducer or catheter is removed, the second extending members 725b return to their retracted position, thereby closing or partially closing the longitudinal channel 755. The covering 740 also contributes to the closure of the longitudinal channel 755 and reduction or elimination of blood leakage or seepage through the longitudinal channel.

[0103] Referring also to FIGS. 60-62, the ACD 700 is deployed using a deployment tool 775. The deployment tube includes a handle 780, an extension 783, a guide 786, and a pusher tube 789. The guide 786 extends from the extension 783 and includes a first longitudinal channel 791 and a longitudinal ridge 792 that passes along the inner surface of the first longitudinal channel 791. The pusher tube 789 is slidably mounted within the first longitudinal channel 791 and includes a second longitudinal channel 793, a pusher surface 794, and a groove 796 that is configured to slide over the longitudinal ridge 792. The guide 786 and the pusher tube 789 include longitudinal slots 797, 798 so that the deployment tool 775 can be placed around the catheter or introducer. With the ACD 700 positioned over a catheter or introducer 120, and positioned within the longitudinal channel 791 in the guide 786, the physician pushes the ACD 700 along the introducer 120 into the vessel using the pusher tube 789. Of course, the ACD can be placed within an arteriotomy using other deployment tools or even by hand.

[0104] The ACDs herein may contain a metallic braid, coil, sheet, strip, wire, rod, or other configuration on the inner diameter, outer diameter, within, and/or a combination of these. The metallic material could be made from superelastic/shape memory alloys such as Nitinol. The metallic braid or coil could be annealed in one configuration during manufacture and processed and packaged in another configuration. When the material is exposed to normal body temperature (i.e., 37° C.), it will be set to either expand apart or contract inward depending on the design and annealed geometry (diameter). This characteristic may assist with the closure of the ACD.

[0105] It is important to understand basic terminology when describing metals with elastic, superelastic, or shape memory behavior. Elasticity is the ability of the metal, under a bending load, for example, to deflect (i.e., strain) and not take a permanent "set" when the load (i.e., stress) is removed. Common elastic metals can strain to about two percent before

they set. Superelastic metals are unique in that they can withstand up to about ten percent strain before taking a set. This is attributed to a “stress-induced” phase change within the metal to allow it to withstand such dramatic levels of strain. Depending on the composition of the metal, this temperature that allows such a phase change can vary. And if the metal is “set” at one temperature, and then the temperature is changed, the metal can return to an “unset” shape. Then, upon returning to the previous “set” temperature, the shape changes back. This is a “shape-memory” effect due to the change in temperature changing the phase within the metal.

**[0106]** Elasticity is a key feature of superelastic materials. When a metal is loaded (i.e., stressed) and undergoes, for example, bending, it may deflect (i.e., strain) in a “springy” fashion and tend to return to its original shape when the load is removed, or it may tend to “set” and stay in a bent condition. This ability to return to the original shape is a measure of the elasticity or “resilience” of the metal. This ability for a metal to be resilient is desirable for such things as springs, shock absorbing devices, and even wire for orthodontic braces where the ability to deflect, but not deform (i.e., set) is important to maintain an applied force.

**[0107]** If, under a bending load, the metal takes a set, it is said to have plastically (versus elastically) deformed. This is because the imposed stress, produced by the bending load, has exceeded the “yield strength” (stress) of the metal. Technically, this level of stress that produces a set, is referred to as the “elastic limit”, but is about the same as the yield strength. If the applied load increases past the yield strength of the metal, it will produce more plasticity and can eventually break. The higher the yield strength of the metal, the more elastic it is. “Good” elastic metals can accommodate up to about two percent strain prior to taking a set. But this is not the only factor governing “elasticity”.

**[0108]** Another factor that determines the ability of a metal to deflect to a given, desired amount, but not take a set, is the “elastic modulus”, or often called the modulus of elasticity. The modulus of the metal is an inherent property. Steels, for example, have a relatively high modulus (30 msi) while the more flexible aluminum has a lower modulus of about 10 msi. The modulus for titanium alloys is generally between 12 and 15 msi.

**[0109]** Resilience is the overall measure of elasticity or “spring-back ability” of a metal. The ratio of the yield strength divided by the modulus of the metal is the resilience. Although it is one thing for a metal to be resilient, it must also have sufficient strength for the intended service conditions.

**[0110]** As discussed above, when a metal is loaded, each increment of load (stress) produces a given increment of deflection (strain) within the metal. And the metal remains elastic if the applied is below the yield stress. However, there is a unique class of metal alloys that behave in an even more elastic manner. These are the “superelastic” metals, where, for a given applied stress (load) increment, the strain in the metal can reach 5 or 6 percent or more without taking a set. In these types of metals, the overall strain required to produce a set can reach an impressive 10 percent. This phenomenon is related to a phase change within the metal, and which is induced by the applied stress. This “stress-induced” phase change can also allow the metal to be set at one temperature and return to another shape at another temperature. This is a “shape-memory” effect, discussed below.

**[0111]** The most common superelastic metal, used in many commercial applications, is an alloy comprised of about equal

parts of nickel (Ni) and titanium (Ti), and has a trade name of “Nitinol”. It is also referred to as “NiTi”. By slightly varying the ratios of the nickel and titanium in Nitinol, the stability of the internal phases in the metal can be changed. Basically, there are two phases: (1) an “austenite” phase and (2) a lower-temperature, “martensite” phase. When the metal is in an austenitic phase condition and is stressed, then a stress-induced martensite forms, resulting in the super-elasticity. This is reversible, and the original shape returns upon release of the applied stress.

**[0112]** In general, the Ni-to-Ti ratio in the Nitinol is selected so that the stress-induced martensite forms at ambient temperatures for the case of super-elastic brace and support devices, which are used in ambient conditions. The specific composition can be selected to result in the desired temperature for the formation of the martensite phase ( $M_s$ ) and the lower temperature ( $M_f$ ) at which this transformation finishes. Both the  $M_s$  and  $M_f$  temperatures are below the temperature at which the austenite phase is stable ( $A_s$  and  $A_f$ ). The performance of an ACD can be further enhanced with the use of superelastic materials such as Nitinol. The superelasticity allows for greatly improved collapsibility, which will return to its intended original shape when the introducer (or catheter) is removed from the inside of the ACD. The high degree of flexibility is also more compatible with the stiffness of the engaged vessel.

**[0113]** By manipulating the composition of Nitinol, a variety of stress-induced superelastic properties can result, and over a desired, predetermined service temperature range. This allows the metal to behave in a “shape-memory” or “shape recovery” fashion. In this regard, the metal is “set” to a predetermined, desired shape at one temperature when in a martensitic condition, and which returns to the original shape when the temperature is returned to the austenitic temperature.

**[0114]** The shape memory phenomenon occurs from a reversible crystalline phase change between austenite and the lower-temperature martensite. In addition to this transformation occurring from an induced stress as described previously, it can, of course, also change with temperature variations. This transformation is reversible, but the temperatures at which these phase changes start and finish differs depending on whether it is heated or cooled. This difference is referred to as a hysteresis cycle. This cycle is characterized by the four temperatures mentioned previously,  $A_s$ ,  $A_f$ ,  $M_s$ , and  $M_f$ . Upon heating from a lower-temperature martensite, the transformation to austenite begins at the  $A_s$ , and will be fully austenite at  $A_f$ . And upon cooling, austenite will begin to transform back to martensite at the  $M_s$  temperature, and become fully martensitic at the  $M_f$ . Again, the specific composition of the alloy can result in a desired combination of these four transformation temperatures.

**[0115]** In the malleable martensitic state, the alloy can be easily deformed (set). Then upon heating back to the austenitic temperature, the alloy will freely recover back to its original shape. Then if cooled back to the martensitic state, the deformed shape reforms. The typical sequence of utilizing this shape memory property is to set the shape of, for example, a stent or anastomosis connector, while in the higher-temperature austenitic state. Then, when cooled, deform the martensite material, and then heat to recover the original shape.

**[0116]** Based on the background information provided above, it can be seen that if the Nitinol material requires an

exceptionally tight bend, and one that would normally exceed the elastic limit of the material and thus permanently deform it, a bend can be placed in the device and the device annealed to relieve bending stresses within the device. Following this first bend, the device can be bent further to produce an even sharper bend, and then re-annealed to alleviate the stress from this additional bending. This process can be repeated to attain the desired, sharp bend or radii that would otherwise permanently deform the device if the bend were attempted in a single bending event. The process for recovery from the position of the most recent bend is then performed as described above.

[0117] Although the example of Nitinol, discussed above, is, by far the most popular of the superelastic metals, there are other alloys that can also exhibit superelastic or shape-memory behavior. These include the following:

[0118] Copper—40 at % Zinc

[0119] Copper—14 wt % Aluminum-4 wt % Nickel

[0120] Iron—32 wt % Manganese-6 wt % Silicon

[0121] Gold—5 to 50 at % Cadmium

[0122] Nickel—36 to 38 at % Aluminum

[0123] Iron—25 at % Platinum

[0124] Titanium—40 at % Nickel-1 Oat % Copper

[0125] Manganese—5 to 35 at % Copper

[0126] Titanium—49 to 51 at % Nickel (Nitinol)

[0127] Nitinol, because of the large amount of titanium in the composition, has been the only FDA approved superelastic/shape memory alloy for medical implant devices. The corrosion resistance of Nitinol is superior to that of commonly used 316L stainless steel, and, if surface oxidized or passivated carefully, can reach corrosion resistance comparable to the most popular titanium implant alloy, Ti6Al4V. Similarly, the metal piece can be electropolished to improve its biocompatibility and blood compatibility. Biocompatibility studies have routinely showed Nitinol as a metal with suitable biocompatibility for medical device applications.

[0128] In summary, there are various ways of describing elasticity, but the main criterion is the ability of the metal to return to its initial, pre-loaded shape. Some metals can only deflect a couple percent and remain elastic while others, such as superelastic Nitinol, can deflect up to about ten percent. Nitinol is also biocompatible and corrosion resistant. This unique combination of properties allows a device made of Nitinol, such as an arterial closure device, to be fully collapsed within a deployment tool and be subsequently released, at a particular site within the vessel, to form its intended service shape.

[0129] Materials other than superelastic/shape memory alloys may be used as reinforcements provided they can be elastically deformed within the temperature, stress, and strain parameters required to maximize the elastic restoring force thereby enabling the tubular closure device to recover to a specific diameter and/or geometry once deployed inside, over, or on top of the vessel or other location. Such materials include other shape memory alloys, spring stainless steel 17-7, other spring metal alloys such as Elgiloy™, Inconel™, superelastic polymers, etc.

[0130] When thermally forming superelastic/shape memory reinforcements, the superelastic/shape memory material(s), previously cut into the desired pattern and/or length, are stressed into the desired resting configuration over a mandrel or other forming fixture having the desired resting shape of the tubular plug, depending on the vessel size or other location where the ACD or plug is intended to be used,

and the material is heated to between 300 and 650° Celsius for a period of time, typically between 30 seconds and 30 minutes. Once the volume of superelastic material reaches the desired temperature, the superelastic material is quenched by inserting into chilled water or other fluid, or otherwise allowed to return to ambient temperature. As such, the superelastic reinforcements are fabricated into their resting configuration. The superelastic/shape memory reinforcements may be full or partial length or width of the ACD or tubular plug.

[0131] Any metal or metal alloy, such as a superelastic/shape memory alloy that comes in contact with blood and/or tissue can be electropolished. Electropolishing may reduce platelet adhesion causing thrombosis, and encourage endothelialization of the exposed metallic areas. Electropolishing also beneficially removes or reduces flash and other artifacts from the fabrication of the device.

[0132] Superelastic/shape memory materials, such as tubular, rectangular, wire, braid, flat, round, combination or other structures also can be used in the design of the closure device, to assist with grasping, contacting, bringing tissue together, sealing, or other desired function. When used as a hollow conduit or reinforcement to a conduit, the superelastic/shape memory materials could be used to resist compressive closure and act as a flexible reinforcing strain relief to prevent kinking and to prevent the conduit from closing.

[0133] Numerous modifications and/or additions to the above-described embodiments and implementations are readily apparent to one skilled in the art. It is intended that the scope of the present embodiments and implementations extend to all such modifications and/or additions and that the scope of the present embodiments and implementations is limited solely by the claims.

[0134] For example, the engagement/contact section of the deployment tool can have a cross sectional geometry of a complete circle that may be designed to split away from the introducer once the closure device has been advanced/deployed. Splitting could be accomplished by having thinned or weakened areas in the wall of the deployment device tubing, such as linear perforations, or linear scores, combination, or other perforation configuration. This version would require that the deployment tool be back loaded onto the introducer before the closure device is placed onto the introducer and prior to insertion into the vessel.

[0135] The deployment tool can be a clip-on tool, can compress the device to reduce the cross sectional profile prior to insertion and/or may include a constraining sheath to reduce a section, or sections of the device during insertion to the target site. This version would be particularly useful for bringing two tissue walls together while yet providing a conduit between the tissues.

[0136] The proximal end of the ACDs described herein may be closed using hemostats, or other tools, by pinching the end together until the inner diameter bonds, or compresses together. Adhesive may be used to assist in the closure of the device.

[0137] The proximal edge of the closure device and the distal (or other) edge of the advancement/deployment tool can have interlocking geometries to aid control during advancement (particularly when inserting by twisting or turning while advancing into the vessel).

[0138] The proximal edge or end of the closure device may have a collar made of a superelastic/shape memory material, an elastic combination of materials or suitable elastic mate-

rials that would compress the end of the device together once the introducer is removed from the inner diameter of the closure device. As previously mentioned, the closing and sealing of the device may be enhanced with an adhesive, swellable material, or other coating or layer.

**[0139]** The closure means can be other than a tubular structure, such as a plug. A special introducer, having multi-lumens, one for the catheter or other device, and at least one for the hemostatic plug material. The hemostatic material, and matching geometry plunger would be inserted into the proximal end of the special introducer. As the plunger is advanced, the hemostatic material is advanced into position and the introducer is withdrawn from the vessel.

**[0140]** The basic device, system and method can be sized and configured for medical devices other than vascular introducers, such as guide wires, catheters, laparoscope, endoscope, trocar, cannula, electrode wire, or other.

**[0141]** Using the tubular closure device, especially when made from swellable material, as a reversible sterilization method for women by occluding the fallopian tubes, and men by occluding the vas ducts or tubes.

**[0142]** A modified version of the device and system can be used for the closure of septal defects in the heart, as well as anywhere else in the body. For this, as well as other additional applications, the clip on section of the deployment tool would be modified to fit onto the catheter, and be long enough (such as, e.g., full catheter length) to be remotely advanced from the proximal end of the catheter. The deployment tool also may be modified and used to compress the device during insertion into the body to thereby reduce the cross-sectional profile during insertion. The deployment method may be enabled by longitudinal movement, manipulation, or retraction of the deployment tool away from the closure device, which removes the compression of the device and allows the device to expand and fill in the opening, such as a septal defect.

**[0143]** The ACDs described herein can be used for cardiovascular applications where hemostasis (temporary or permanent) is desired. Additionally, the ACDs can be used with simple modifications for any tubular, duct, organ, hollow body cavity, or other structures or tissues, where temporary or permanent sealing or plugging is needed, or alternatively, where a conduit or conduit reinforcement is desired. For conduit or conduit reinforcement applications, the material and design used thereby would be sufficiently resistant to compressive closure while still remaining flexible, e.g., longitudinally and/or radially flexible.

**[0144]** The ACDs described herein also can be used for gastric bypass procedures, general tissue bunching or bringing tissues together, and on or in other vessels, organs, tissues, bones, and/or other body tissues than those specifically described.

**[0145]** While several particular forms of the arterial closure device and deployment tool have been illustrated and described, it will be apparent that various modifications and combinations of the inventions detailed in the text and drawings can be made without departing from the spirit and scope of the inventions. For example, references to materials of construction, methods of construction, specific dimensions, shapes, utilities or applications are also not intended to be limiting in any manner and other materials and dimensions could be substituted and remain within the spirit and scope of the inventions. Accordingly, it is not intended that the inven-

tions be limited, except as by the appended claims. Accordingly, other embodiments are within the scope of the following claims and figures.

**1-17.** (canceled)

**18.** A method of closing an opening in the wall of a tubular vessel, the method comprising:

providing a tubular medical device; and

providing a tubular vessel closure device configured to close an opening in a tubular vessel, the tubular vessel closure device comprising a tubular member having a proximal end and a distal end with a channel passing between the proximal end and the distal end and comprising at least two opposed members formed at least in part from a superelastic/shape memory material and connected to the distal end of the tubular member at a proximal end of the opposed members, wherein the opposed members are configured to be spread apart at their distal end upon application of a force and to move towards each other at their distal end upon removal of the force and thereby appose edges of the opening to close the opening, and the tubular member is configured to be slidably mounted to the tubular medical device;

advancing the tubular medical device to the opening in the wall of the tubular vessel;

advancing the tubular vessel closure device over the tubular medical device until the tubular vessel closure device is proximal or in contact with the wall of the tubular vessel and the distal ends of the opposed members are separated at their distal ends by application of a force; and removing the force, whereby the opposed members move towards each other while in contact with the vessel wall to close an opening in the vessel wall.

**19.** The method of claim **18**, wherein the tubular medical device is removed while the force is removed.

**20.** The method of claim **18**, wherein the tubular medical device is removed after the force is removed.

**21.** The method of claim **33**, wherein the securing means comprises one or more of a contact adhesive, a bonding material, barbs, angled edges and protrusions.

**22.** The method of claim **18**, wherein the superelastic/shape memory material comprises a nickel titanium alloy.

**23.** The method of claim **18**, wherein the tubular vessel closure device includes at least one or more of a superelastic/shape memory component, a material that swells or expands when exposed to a fluid, a biodegradable/bioabsorbable material, a therapeutic agent configured to affect healing at the site of implantation of the closure device; or a biocompatible material.

**24-32.** (canceled)

**33.** The method of claim **18**, wherein the opposed members have a surface configured with a securing means to secure the tubular vessel closure device to the tubular vessel.

**34.** The method of claim **18**, wherein the tubular vessel closure device is secured temporarily to the tubular vessel.

**35.** The method of claim **18**, wherein the tubular vessel closure device is secured permanently to the tubular vessel.

**36.** The method of claim **18**, wherein the tubular medical device comprises one or more of an introducer, catheter, tube, guide wire, laparoscope, endoscope, trocar, cannula, or electrode wire.

**37.** The method of claim **18**, further comprising using a deployment device to advance the tubular vessel closure device over the tubular medical device.

**38.** The method of claim **18**, wherein advancing the tubular medical device to the opening in the wall of the tubular vessel comprises threadably advancing the tubular medical device against the vessel.

**39-42.** (canceled)

**43.** The method of claim **37**, wherein the deployment device is mounted to the tubular medical device before or after the tubular medical device has been inserted into the body.

**44.** The method of claim **43**, wherein the deployment device is mounted to the tubular medical device after the tubular medical device has been inserted into the body and the deployment tool is attached to the tubular medical device by one or more: from the side, through a longitudinal slot, or by

using a two piece deployment tool that fits together, whereby the deployment tools covers at least part of the tubular medical device.

**45.** The method of claim **37**, wherein the deployment tool comprises an inner wall and an outer wall and the tubular vessel closure device is configured to be positioned in between the two walls whereby the inner and outer walls optionally covers at least part of the tubular vessel closure device.

**46.** The method of claim **37**, wherein the deployment tool comprises a pusher tube configured to contact at least a part of the tubular vessel closure device for advancing the tubular vessel closure device into the vessel tissue and optionally separate the tubular vessel closure device from the deployment tool.

\* \* \* \* \*

专利名称(译)	动脉切开术闭合装置和技术		
公开(公告)号	<a href="#">US20080114394A1</a>	公开(公告)日	2008-05-15
申请号	US11/933129	申请日	2007-10-31
[标]申请(专利权)人(译)	HOUSER拉塞尔 HARE WILLIAM D		
申请(专利权)人(译)	HOUSER拉塞尔 HARE WILLIAM D		
当前申请(专利权)人(译)	HOUSER拉塞尔 HARE WILLIAM D		
[标]发明人	HOUSER RUSSELL A HARE WILLIAM D		
发明人	HOUSER, RUSSELL A. HARE, WILLIAM D.		
IPC分类号	A61B17/03		
CPC分类号	A61B17/00491 A61B17/0057 A61B2017/00637 A61B2017/2925 A61B2017/00862 A61B2017/00867 A61B2017/00659		
优先权	60/286269 2001-04-24 US 60/300892 2001-06-25 US 60/302255 2001-06-28 US		
外部链接	<a href="#">Espacenet</a> <a href="#">USPTO</a>		

摘要(译)

动脉闭合系统包括动脉闭合装置 (“ACD”) 和展开工具。动脉闭合装置包括第一构件，该第一构件围绕动脉闭合装置的圆周形成扩大部并且构造抵靠血管的外表面接收，连接构件具有比第一构件更小的外径，从第一构件延伸该构件被配置成定位在血管的动脉切开术中，并且纵向通道构造成接收管并在第一构件和连接构件之间通过。展开工具包括手柄，接触部分和在手柄和接触部分之间延伸的延伸部。接触部分设计成与动脉闭合装置配合，以使动脉闭合装置在管上方前进，并将动脉闭合装置展开在血管内。

