



US 20060217748A1

(19) **United States**

(12) **Patent Application Publication**
Ortiz

(10) **Pub. No.: US 2006/0217748 A1**

(43) **Pub. Date: Sep. 28, 2006**

(54) **METHOD FOR HYBRID
GASTRO-JEJUNOSTOMY**

Publication Classification

(75) Inventor: **Mark S. Ortiz**, Milford, OH (US)

(51) **Int. Cl.**
A61B 17/08 (2006.01)

(52) **U.S. Cl.** **606/153; 606/155**

Correspondence Address:
NUTTER MCCLENNEN & FISH LLP
WORLD TRADE CENTER WEST
155 SEAPORT BOULEVARD
BOSTON, MA 02210-2604 (US)

(57) **ABSTRACT**

Disclosed herein are methods for joining one piece to tissue to another piece of tissue. In one embodiment, the method can include inserting an applier device having an actuation portion into a first body lumen through a natural body orifice, forming a first opening in a first piece of tissue within the first lumen and a second opening in a second piece of tissue defining a portion of a second lumen adjacent to the first piece of tissue, and inserting the applier device through the first and second openings such that the actuation portion is between the first and second piece of tissue. The method can further include deploying a fastener into the first and second pieces of tissue through the actuation portion of the applier device, thereby joining the first and second pieces of tissue to form an anastomosis between the first and second lumens.

(73) Assignee: **Ethicon Endo-Surgery, Inc.**, Cincinnati, OH (US)

(21) Appl. No.: **11/277,289**

(22) Filed: **Mar. 23, 2006**

Related U.S. Application Data

(63) Continuation-in-part of application No. 10/675,705, filed on Sep. 30, 2003.
Continuation-in-part of application No. 10/675,077, filed on Sep. 30, 2003.

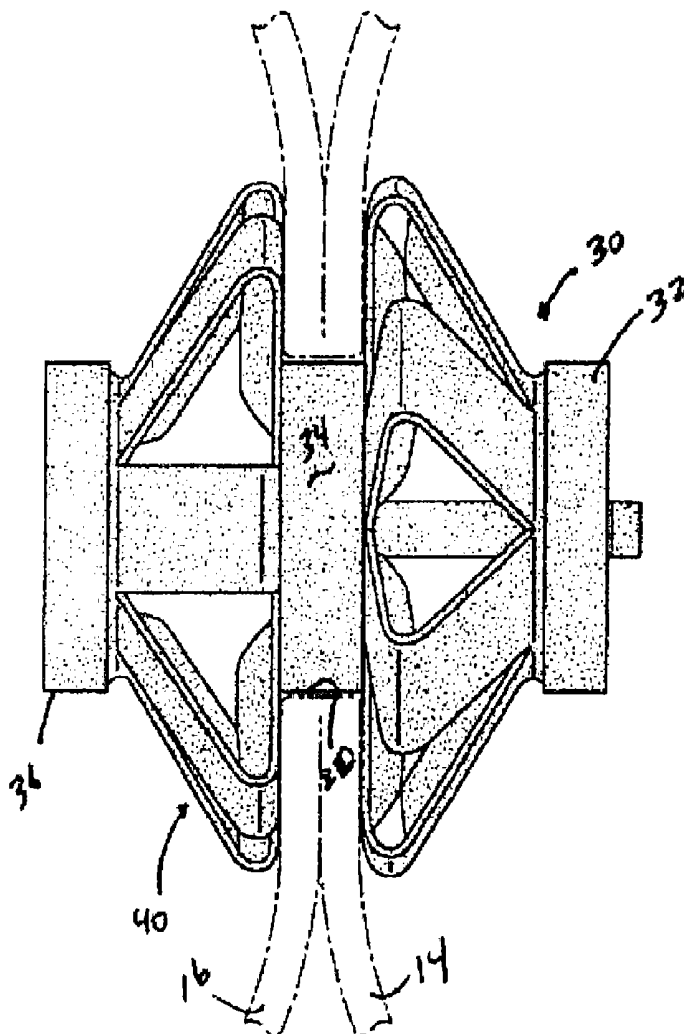

FIG. 1A

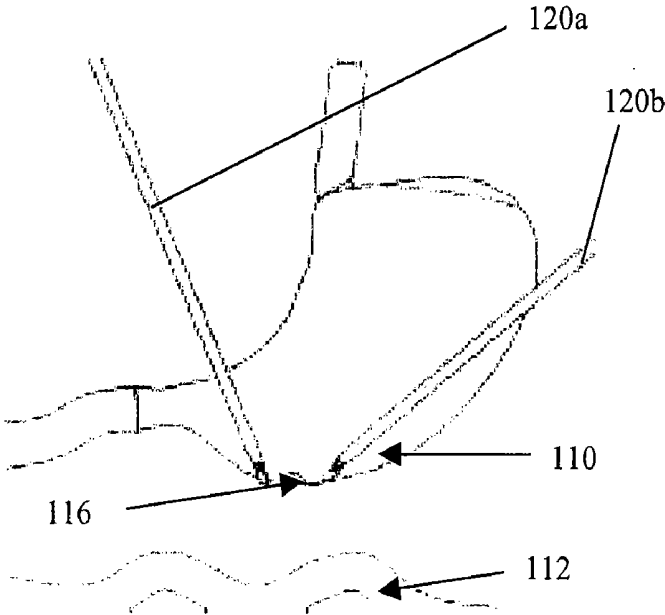

FIG. 1B

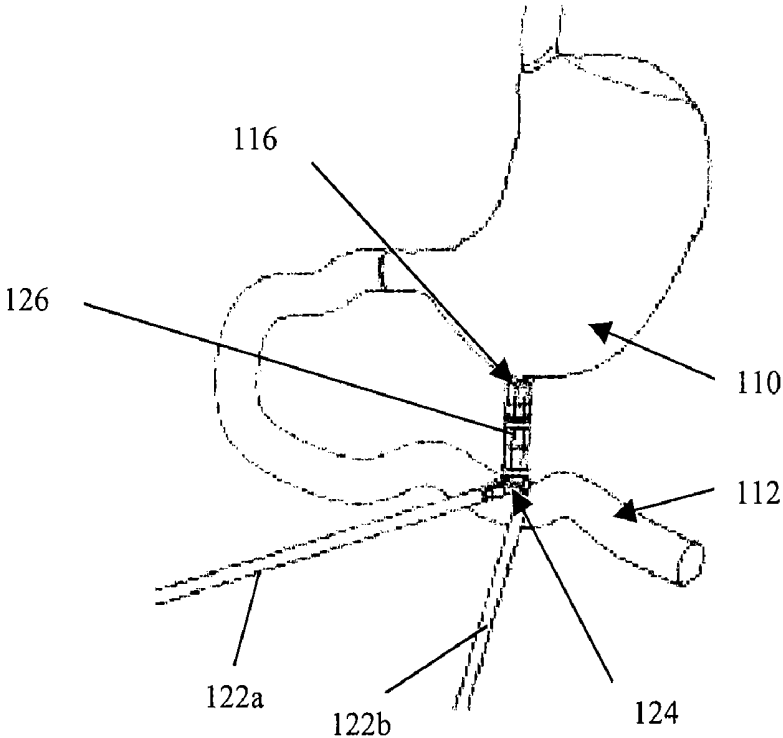

FIG. 1C

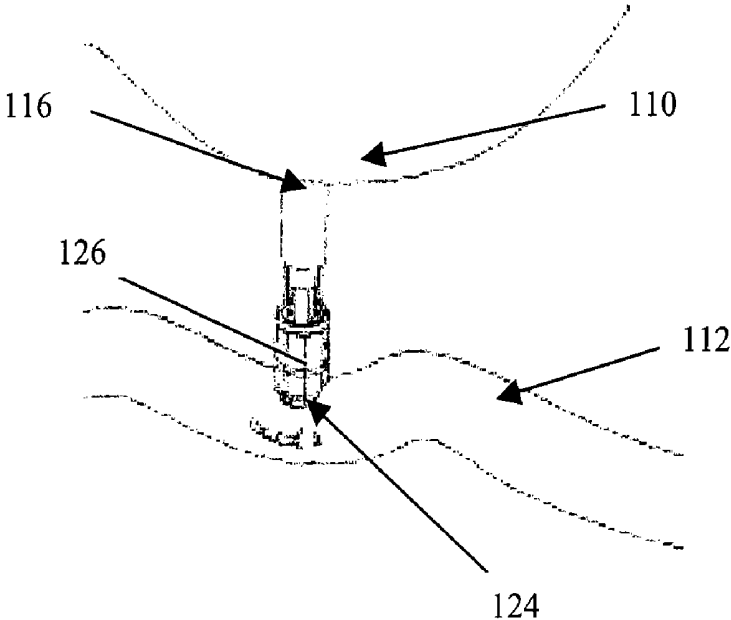

FIG. 1D

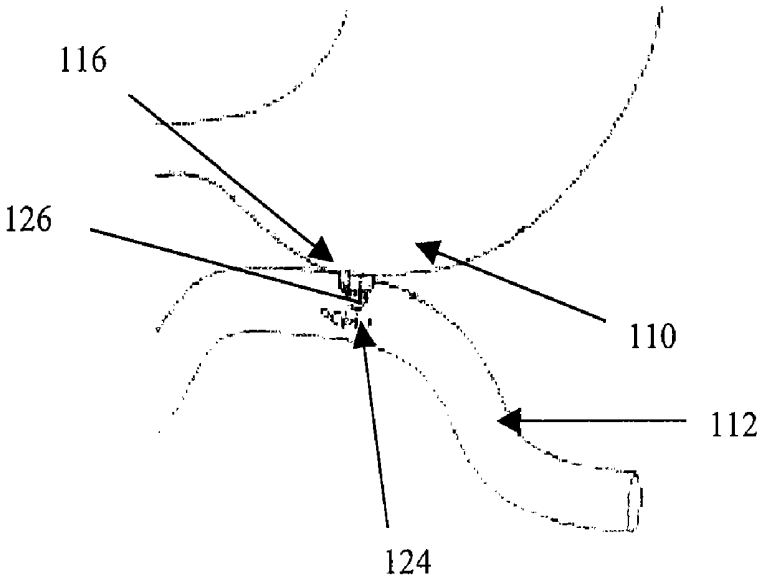

FIG. 1E

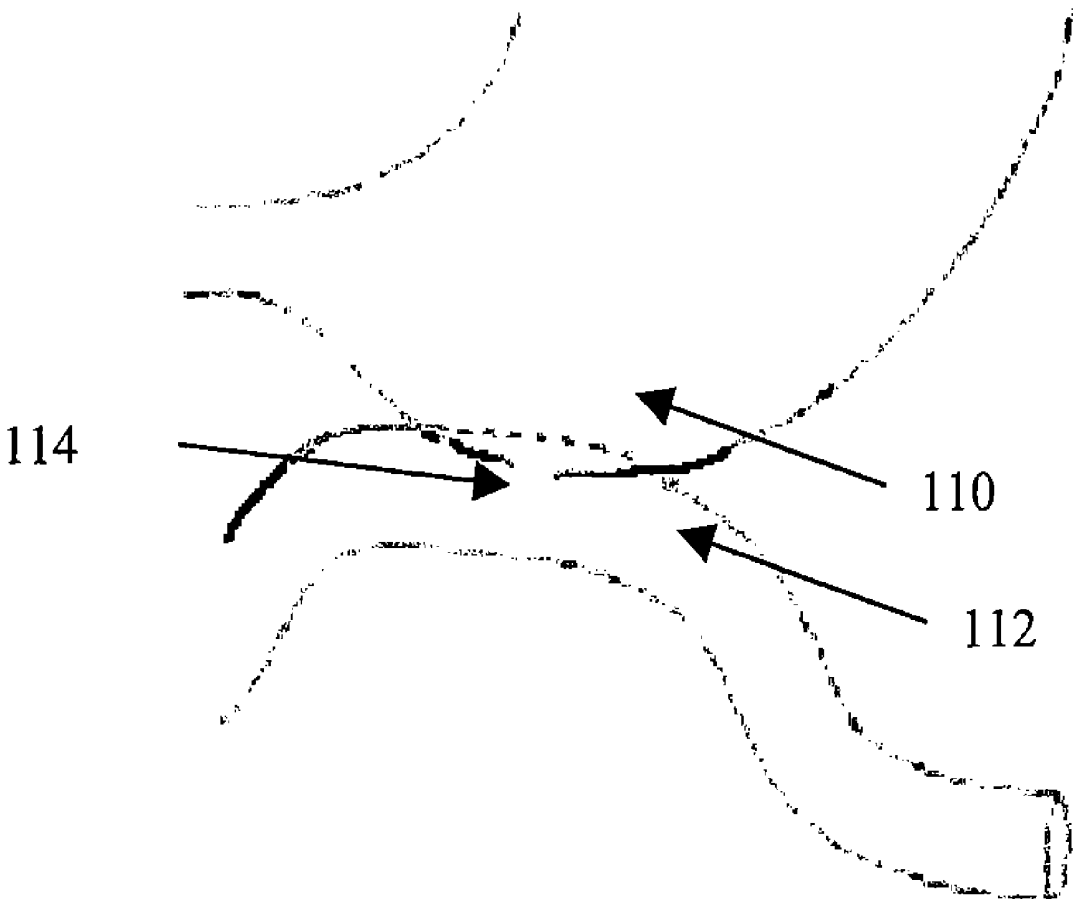

FIG. 2

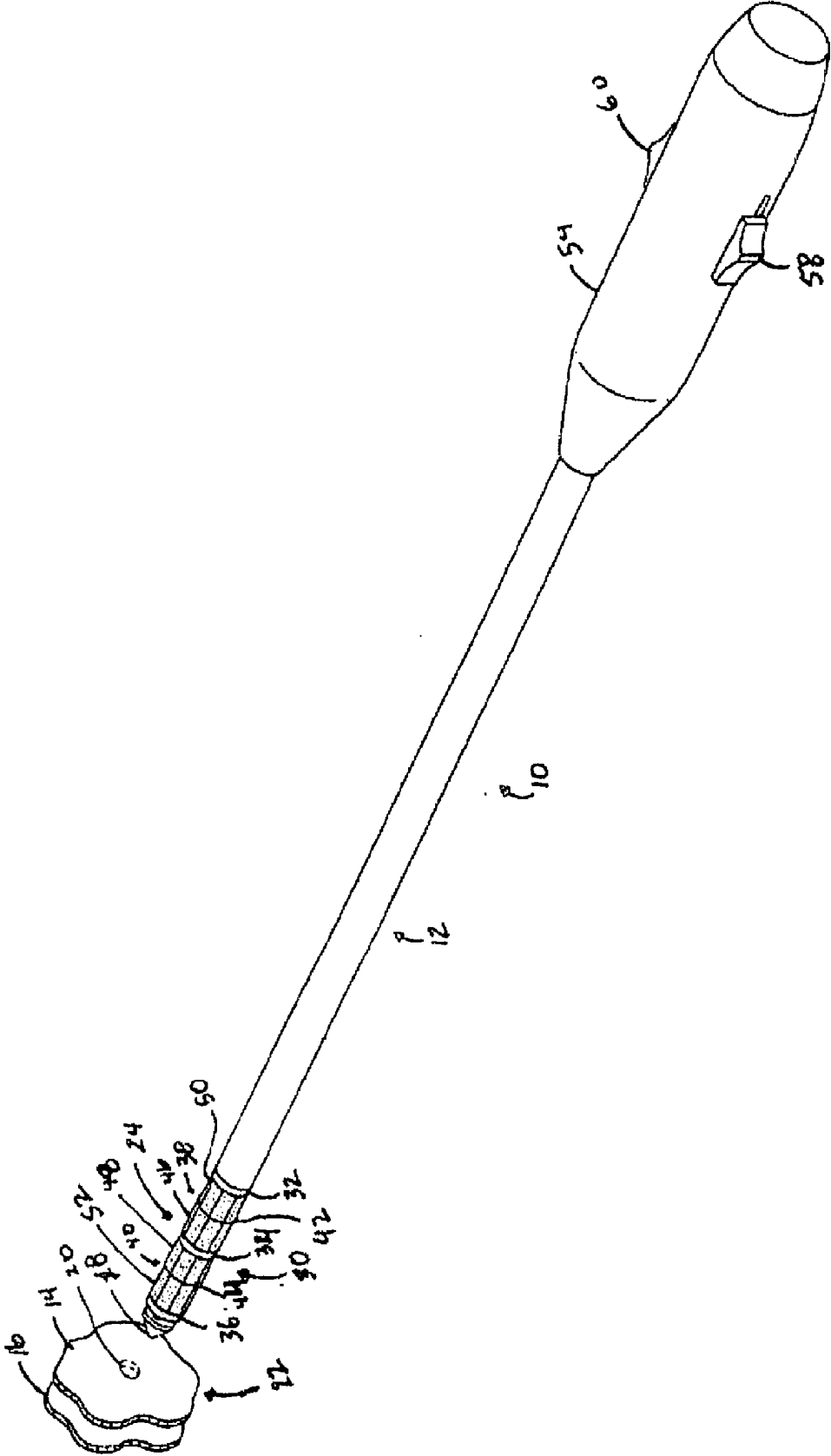

FIG. 3

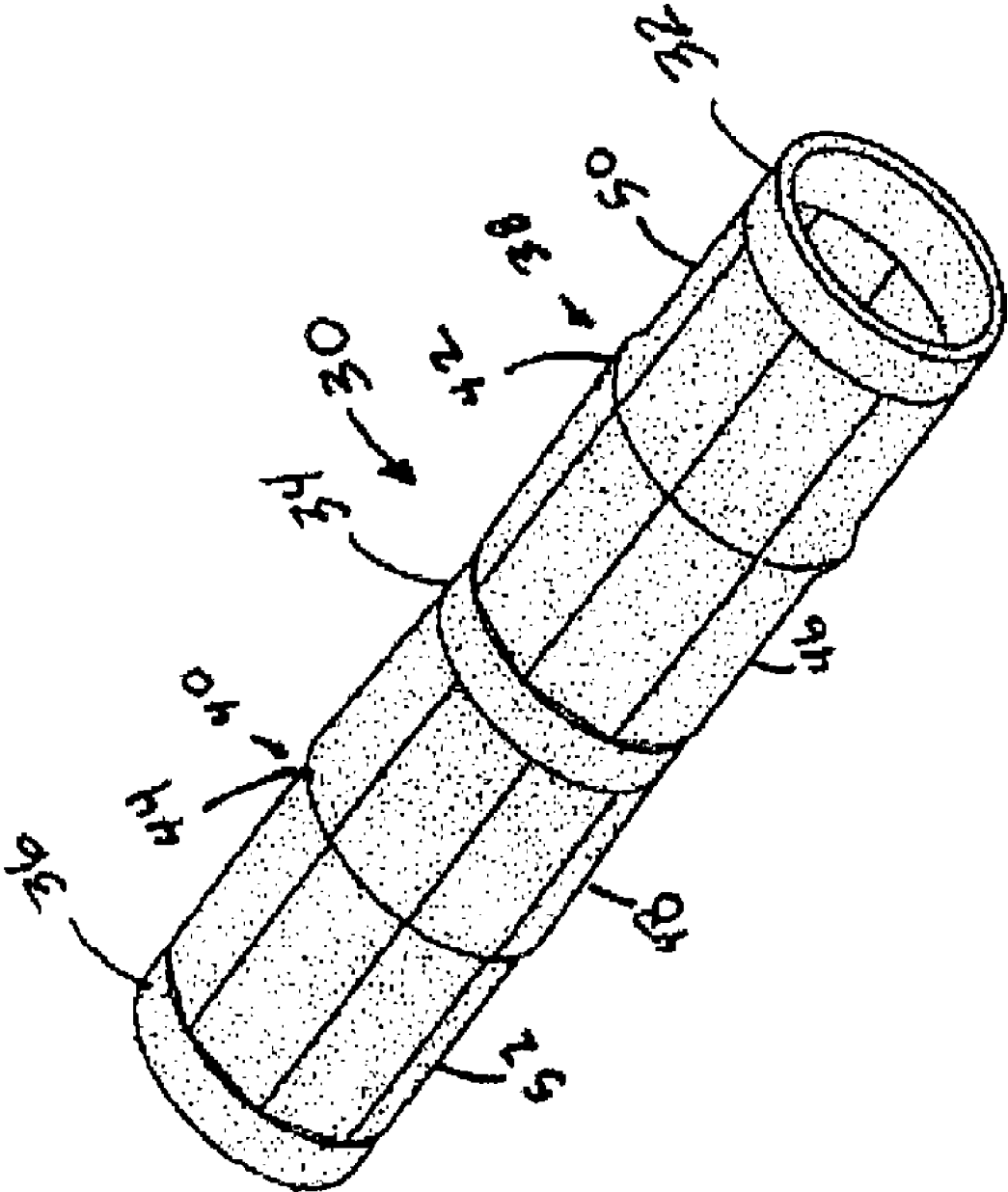

FIG. 4

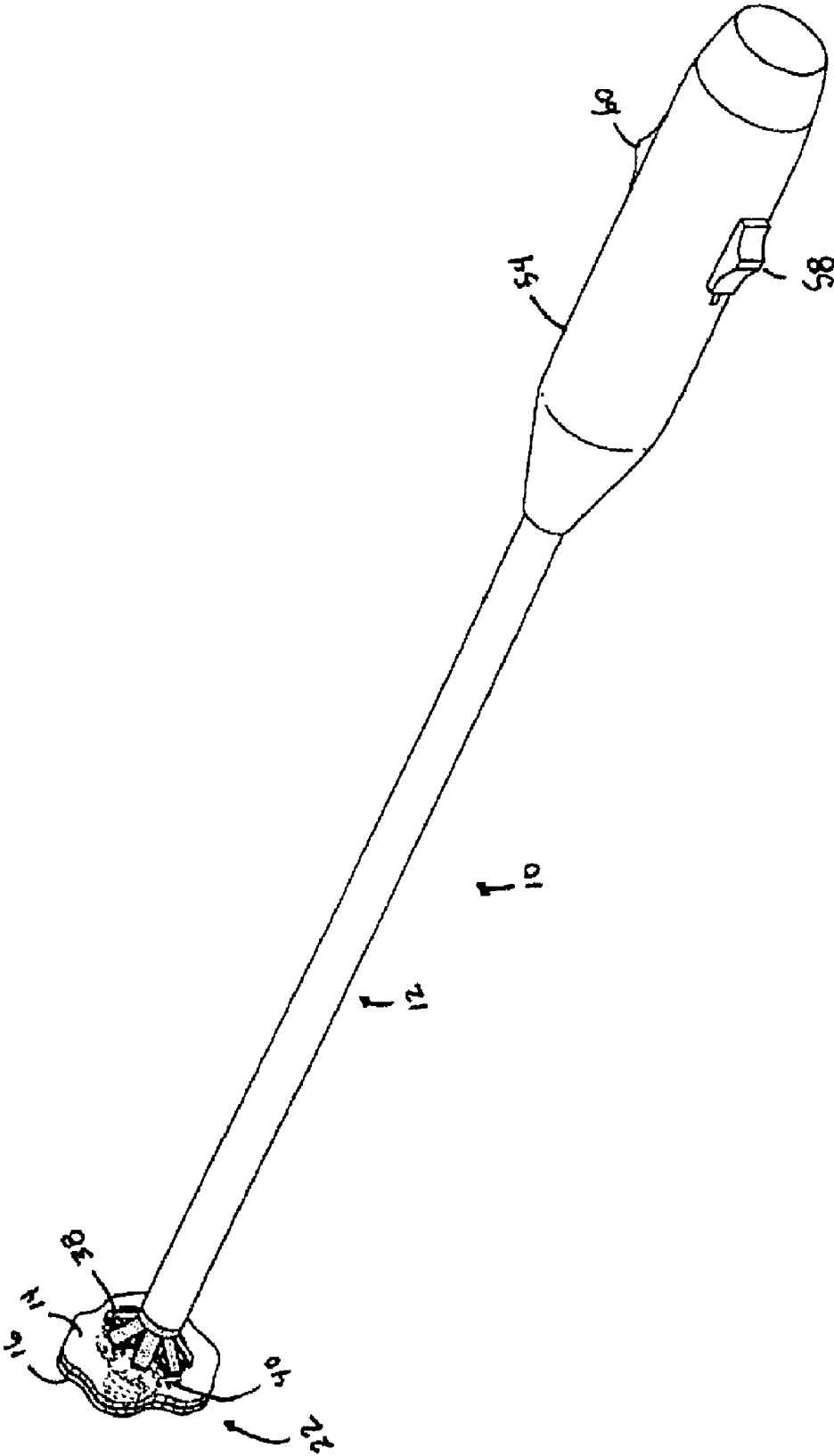
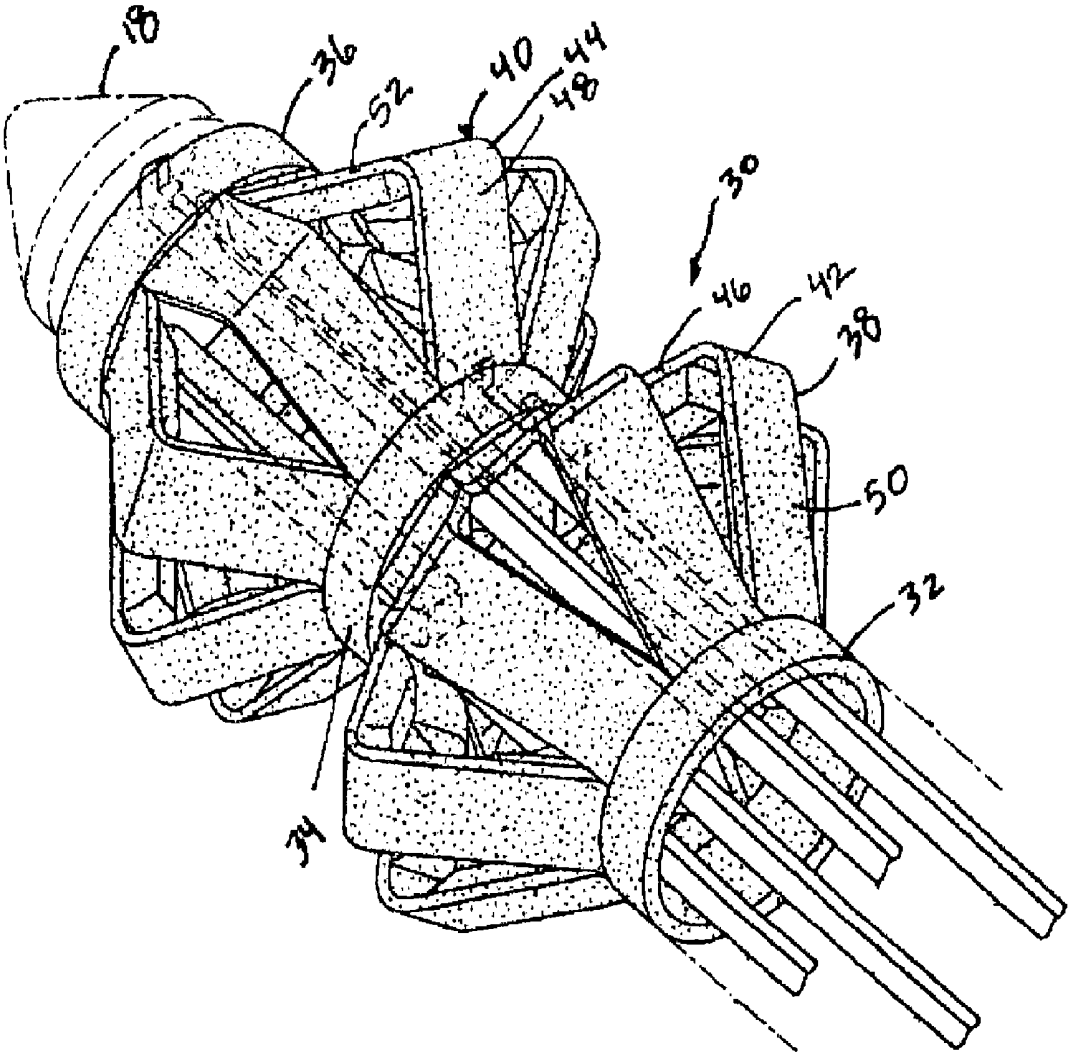

FIG. 5



METHOD FOR HYBRID GASTRO-JEJUNOSTOMY**CROSS-REFERENCE TO RELATED APPLICATIONS**

[0001] The present application is a continuation-in-part of U.S. application Ser. No. 10/675,705, filed Sep. 30, 2003, and entitled "Single Lumen Access Deployable Ring for Intraluminal Anastomosis," which is currently pending, and also a continuation-in part of U.S. application Ser. No. 10/675,077, filed Sep. 30, 2003, and entitled "Applier for Fastener for Single Lumen Access Anastomosis," which is currently pending, both of which are incorporated by reference herein.

FIELD OF THE INVENTION

[0002] The present invention relates to methods for joining one piece of tissue to another piece of tissue.

BACKGROUND OF THE INVENTION

[0003] The percentage of the world population suffering from morbid obesity is steadily increasing. Severely obese persons are susceptible to increased risk of heart disease, stroke, diabetes, pulmonary disease, and accidents. Because of the effect of morbid obesity on the life of the patient, methods of treating morbid obesity are being researched.

[0004] Numerous non-operative therapies for morbid obesity have been tried with virtually no permanent success. Dietary counseling, behavioral modification, wiring a patient's jaws shut, and pharmacological methods have all been tried, and though temporarily effective, have failed to correct the condition. Further, techniques such as introducing an object in the stomach to fill the stomach, such as an esophago-gastric balloon, have also been used to treat the condition. However, such approaches tend to cause irritation to the stomach and are not effective long-term.

[0005] Surgical treatments for morbid obesity have been increasingly used with greater success. These approaches may be generalized as those that reduce the effective size of the stomach, limiting the amount of food intake, and those that create malabsorption of the food that is eaten. For instance, some patients benefit from adjustable gastric bands (AGB) that are advantageously laparoscopically placed about the stomach to form a stoma of a desired size that allows food to fill an upper portion of the stomach, causing a feeling of satiety. To allow adjustment of the size of the stoma after implantation, a fluid conduit communicates between an inwardly presented fluid bladder of the AGB to a fluid injection port subcutaneously placed in front of the patient's sternum. A syringe needle may then inject or withdraw fluid as desired to adjust the AGB.

[0006] Although an effective approach to obesity for some, other patients may find the lifestyle changes undesirable, necessitated by the restricted amount of food intake. In addition, the medical condition of the patient may suggest the need for a more permanent solution. To that end, surgical approaches have been used to alter portions of the stomach and/or small intestine available for digesting food. Creating an anastomosis, or the surgical formation of a passage between two normally distinct vessels, is a critical step in many of these surgical procedures. This is particularly true of gastric bypass procedures in which two portions of the

small intestine are joined together and another portion of the small intestine is joined to the stomach of the patient. This is also true of surgery to alleviate a blockage(s) in the common bile duct by draining bile from the duct to the small intestine during surgery for pancreatic cancer. With particular reference to gastric bypass procedures, current methods of performing a laparoscopic anastomosis for a gastric bypass include stapling, suturing, and using biofragmentable rings, each of which has significant challenges.

[0007] Consequently, there is a general need for an improved method for joining one piece of tissue to another piece of tissue, and in particular for forming an anastomosis between the small bowel and the stomach.

SUMMARY OF THE INVENTION

[0008] The present invention provides methods for joining one piece of tissue to another piece of tissue. In one aspect, a method for joining tissue includes inserting an applier device having an actuation portion into a first body lumen through a natural body orifice, forming a first opening in a first piece of tissue within the first lumen and a second opening in a second piece of tissue defining a portion of a second lumen adjacent to the first piece of tissue, and inserting the applier device through the first and second openings such that the actuation portion is between the first and second pieces of tissue. The method can further include deploying a fastener into the first and second pieces of tissue through the actuation portion of the applier device to join the first and second pieces of tissue to form an anastomosis between the first and second lumens. The applier device can be inserted endoscopically into the natural body orifice, and in one embodiment where the first piece of tissue can be part of a stomach and the second piece of tissue can be part of a jejunum, the device can endoscopically access the stomach through the esophagus.

[0009] The first and second openings can be formed using a variety of techniques. In one embodiment, the distal end of the applier device can be used as a marker to facilitate formation of the first opening. The first and second openings can then be formed via a laparoscopic surgical procedure, or alternatively the first opening can be formed using a cutting member associated with a distal end of the applier device and the second opening can be formed using a cutting element that accesses a site of the second opening by a laparoscopic port. Once formed, and in order to facilitate insertion of the applier device therein, the first and second openings can be expanded using a tapered distal end of the applier device or at least one grasping element.

[0010] The techniques used to position the actuation portion between the first and second pieces of tissue and to deploy a fastener therein can vary depending upon the configuration of the applier device, and in particular, the configuration of the actuation portion of the applier device and the fastener. In one embodiment, the actuation portion of the applier device can include at least one fastener having proximal and distal ring members joined by a connecting element, with the proximal and distal ring members each having a plurality of arms extending therefrom that are adapted to engage tissue. In this embodiment, positioning the actuation portion can include positioning the distal ring member of the fastener such that it is adjacent to the second piece of tissue and positioning the proximal ring member of

the fastener such that it is adjacent to the first piece of tissue. This allows the connecting element to extend between the first and second pieces of tissue. The fastener can be deployed by actuating the actuation portion such that the plurality of arms of the proximal and distal ring members move from a first resting position to a second actuated position such that the plurality of arms engage and hold together the first and second pieces of tissue. The plurality of arms of the proximal and distal ring members can be independently or simultaneously actuated to engage the first and second pieces of tissue. In one embodiment, the fastener can also optionally be disengaged from a catch located on the actuation portion that holds the fastener on the actuation portion prior to any deployment into tissue.

[0011] In another aspect, a method for forming an anastomosis can include endoscopically inserting an applier device through a natural body orifice, through a lumen and through a first opening formed in a first piece of tissue and a second opening formed in a second piece of tissue, and positioning an actuation portion of the applier device between the first and second pieces of tissue. The method can also include deploying a fastener into the first and second pieces of tissue through the actuation portion of the device to form an anastomosis therebetween.

BRIEF DESCRIPTION OF THE DRAWINGS

[0012] The invention will be more fully understood from the following detailed description taken in conjunction with the accompanying drawings, in which:

[0013] **FIG. 1A** is a schematic illustrating the formation of a first opening in a stomach;

[0014] **FIG. 1B** is a schematic illustrating the insertion of an actuation portion of an applier device through the first opening of **FIG. 1A** and a second opening formed in a jejunum;

[0015] **FIG. 1C** is a schematic illustrating the deployment of a fastener into a distal portion of the jejunum;

[0016] **FIG. 1D** is a schematic illustrating the retraction of the applier device from the jejunum;

[0017] **FIG. 1E** is a schematic illustrating an anastomosis formed between the stomach and the jejunum as a result of the method **FIGS. 1A-1D**;

[0018] **FIG. 2** is perspective view of one embodiment of an applier device having a fastener for use with the method of **FIGS. 1A-1D**;

[0019] **FIG. 3** is a perspective view of the fastener of **FIG. 2**;

[0020] **FIG. 4** is a perspective view of the applier device and fastener of **FIG. 2** after actuation, where the fastener is deployed into tissue;

[0021] **FIG. 5** is a perspective view of the fastener of **FIG. 3** after deployment into tissue; and

[0022] **FIG. 6** is another perspective view of the fastener of **FIG. 3** after deployment into tissue.

DETAILED DESCRIPTION OF THE INVENTION

[0023] Certain exemplary embodiments will now be described to provide an overall understanding of the prin-

ciples of the structure, function, manufacture, and use of the devices and methods disclosed herein. One or more examples of these embodiments are illustrated in the accompanying drawings. Those skilled in the art will understand that the devices and methods specifically described herein and illustrated in the accompanying drawings are non-limiting exemplary embodiments and that the scope of the present invention is defined solely by the claims. The features illustrated or described in connection with one exemplary embodiment may be combined with the features of other embodiments. Such modifications and variations are intended to be included within the scope of the present invention.

[0024] The present invention generally provides methods for joining one piece of tissue to another piece of tissue. In one embodiment, the method can include inserting an applier device having an actuation portion into a first body lumen through a natural body orifice, forming a first opening in a first piece of tissue within the first lumen and a second opening in a second piece of tissue defining a portion of a second lumen adjacent to the first piece of tissue, and inserting the applier device through the first and second openings such that the actuation portion is between the first and second piece of tissue. The method can further include deploying a fastener into the first and second pieces of tissue through the actuation portion of the applier device, thereby joining the first and second pieces of tissue to form an anastomosis between the first and second lumens. One skilled in the art will appreciate that the applier device can be inserted through a variety of lumens, such as natural body lumens, and the lumens can be accessed through natural body orifices, such as the esophagus and the rectum, or through a surgically-created portal, during a variety of medical procedures which require tissues to be joined. By way of non-limiting example, such medical procedures include a Roux-en-Y procedure or other bariatric procedures which can require the joining of the jejunum to a stomach or stomach part, or bypass procedures for bypassing a cancerous or non-cancerous obstruction(s) in tissue, such as the duodenum. This method is particularly advantageous in that it minimizes the number of access lumens formed in a patient by relying on natural orifices and/or a single created lumen or portal, such as a laparoscopic portal, for the insertion of the applier device.

[0025] **FIGS. 1A-1E** illustrate one exemplary embodiment of a method for forming an anastomosis **114** between a part of a jejunum **112** and a part of a stomach **110**. Following preparation of the patient and the surgical site as known in the art, an applier device **126** can be inserted transorally, and guided through the esophagus into the stomach **110**. The applier device **126** can then be positioned at a site adjacent a wall of the stomach **110**, and the tip of the applier device **126** can optionally form a slight protrusion (not shown) on the distal wall thereof. This protrusion can serve as a marker that allows a surgeon to identify the location of the applier device **126** within the stomach **110**, such that the surgeon can form a first opening **116** in the stomach **110** from which the applier device **126** can exit the stomach **110**. Alternatively, and in other embodiments, traditional monitoring and/or tracking techniques, such as radioopaque bands located on the distal tip of the applier device, can be used to facilitate locating and/or tracking of the applier device and formation of the first opening.

[0026] The first opening 116 can be formed using a variety of techniques, and in one embodiment, the first opening can be formed from within the stomach 110 using a cutting member (not shown), such as a blade, that is located on the distal end of the applier device 126. Alternatively, and referring to FIG. 1A, the first opening 116 can be formed using at least one cutting element (cutting elements 120a, 120b are shown), such as scissors, that can be inserted by a laparoscopic surgical technique to a location adjacent to the position of the applier device 126 external to the stomach 110. The first opening 116 can also be formed using a combination of above-mentioned laparoscopic and endoscopic techniques. Following formation, the first opening 116 can be expanded to allow the applier device 126, and in particular the actuation portion thereof, to be inserted there-through and directed towards the jejunum 112. Any technique known in the art can be used to expand the tissue of the stomach 110, and exemplary techniques can include the use of a tapered element located on the distal end of the applier device, the use of graspers, or some other element that is adapted to hold open at least a portion of the first opening to enlarge it, and combinations thereof. This insertion technique is particularly advantageous in that it does not require the formation of a new incision to allow the applier device 126 to access the jejunum 112. As a result, the laparoscopic port used to form the first opening 116 can be left in position for the formation of a second opening 124 in the jejunum 112, as will be discussed in more detail below.

[0027] As noted above and once the applier device 126 is moved through the first opening 116 such that it is positioned at the jejunum 112, a second opening 124 for receiving the applier device 126 can be formed in the jejunum 112. The second opening 124 can be formed using techniques similar to those noted above with respect to the formation of the first opening 116 (e.g., a cutting member on the distal end of the applier device, using a cutting element(s) that accesses the site through a laparoscopic port, or combinations thereof). However in an exemplary embodiment, the second opening 124 can be formed using a cutting element(s) that accesses the site through the same laparoscopic port that was used to form the first opening 116. Following formation of the second opening 124, the applier device 126 can be inserted into and through the second opening 124 such that at least a portion of the actuation portion is positioned between the stomach 110 and the jejunum 112 to facilitate the placement of a fastener within the tissues 110, 112. As described above with respect to the formation of the first opening 116 and as shown in FIG. 1B, the second opening 124 can be expanded to facilitate insertion of the applier device 126 therein using a distal end (not shown) of the applier device 126, and additionally or alternatively, two graspers 122a, 122b that are positioned on opposed sides of the second opening 124.

[0028] Once the applier device 126 is positioned at the desired location between the stomach 110 and the jejunum 112, the actuation portion can be actuated to effect the deployment of a fastener into the tissues 110, 112. A variety of techniques can be used to actuate the actuation portion of the applier device 126 to deploy the fastener, and those techniques can depend upon the types of applier devices and fasteners used. However, in one embodiment, as will be described in more detail below, the actuation portion of the applier device can include at least one fastener having proximal and distal ring members joined by a connecting element, with the proximal and distal ring members each

having a plurality of arms extending therefrom that are adapted to engage tissue. The actuation portion can also optionally include a catch for holding the fastener thereto prior to deployment into tissue.

[0029] When such an applier device is used, actuation can cause the fastener to optionally be released from the catch and the plurality of arms formed on the proximal and distal ring members (not shown) to move from a first resting position to a second actuated position such that they engage and hold together opposed tissues of the stomach 110 and the jejunum 112. While the plurality of arms can be independently or simultaneously actuated with respect to one another, in an exemplary embodiment, the plurality of arms on the distal ring member can be actuated prior to the actuation of the plurality of arms on the proximal ring member. As a result, the plurality of arms of the distal end of the fastener can engage the tissue of the jejunum 112, as shown in FIG. 1C. Once the fastener is engaged with the jejunum tissue 112, the applier device 126 can be moved proximally such that it is retracted within the esophagus to cause the jejunum tissue 112 to contact the stomach tissue 110, as shown in FIG. 1D. The proximal ring member can then be deployed into stomach tissue 110 that is located opposite to the already-engaged tissue of the jejunum 112, such that the plurality of arms of the fastener engage the tissue of the stomach 110, causing an anastomosis 114 to form between the stomach 110 and the jejunum 112 (FIG. 1E).

[0030] Following formation of the anastomosis 114, the applier device 126 can be extracted from the stomach 110 transorally, and any laparoscopic instruments can be removed from the surgical site. The site can then optionally be leak tested to ensure that the anastomosis is sound. Over time, the tissue walls can permanently heal together and the fastener can be passed out of the digestive tract, especially if the fastener is biofragmentable.

[0031] As noted above, a variety of types of applier devices and fasteners can be used with the method described herein form an anastomosis. While the applier device and fastener used are generally dependent upon the types of tissues being joined, one exemplary applier device and fastener is shown in FIGS. 2-6. In general, as shown in FIGS. 2 and 4, the applier device 10 includes an elongate implement portion 12 having proximal and distal ends that is dimensionally sized for insertion through a natural or created orifice. The proximal end can include a handle 54 and the distal end can include an actuation portion 24 adapted to hold a fastener 30. The distal end can also have a distal tip 18 that can be adapted to pierce through an opening 20 at an anastomosis site 22 in tissue 14, 16 to facilitate the positioning of the actuation portion 24 within the tissue 14, 16.

[0032] The elongate implement portion 12 can have virtually any configuration, and in an exemplary embodiment, the elongate implement portion 12 can be flexible such that it can be endoscopically inserted into and through an orifice. The handle 54 can be adapted to effect actuation of the fastener, and as shown the applier device 10 includes controls for effecting the actuation of the actuation portion 24 to cause deployment of the fastener 30 into tissue 14, 16. In one embodiment, the controls can include a first slide control 58 and a second slide control 60. The handle 54 can further

include controls to effect illumination of the distal tip so that actuation of at least a portion of the fastener 30 in a lumen can be proximally viewed using an optics unit. The optics unit may be part of an endoscope or the applier device. While the illustrated applier device can be manually positioned and actuated, one skilled in the art will appreciate that the applier device 10 can also be adapted to be remotely positioned and actuated.

[0033] A variety of fasteners can be used with the applier device described herein, and the fasteners can generally have any configuration that is effective to engage and hold tissue. In one embodiment, as shown in FIGS. 3 and 5-6, the fastener 30 has three rings, a proximal ring 32, a center ring 34, and a distal ring 36, that are cylindrically aligned with one another. The proximal ring 32 is longitudinally attached to the center ring 34 by proximal arms 38, which in turn is longitudinally attached to the distal ring 36 by distal arms 40. Each proximal and distal arm 38, 40 is bisected respectively by a hinged joint 42, 44 that defines an inner arm segment 46, 48 that is hingedly attached to the center ring 34, and an outer arm segment 50, 52 that is also hingedly attached to the respective proximal or distal ring 32, 36. The fastener 30 can have a variety of shapes and sizes, however, in its unactuated state as shown in FIG. 3, the fastener 30 has a substantially cylindrical configuration. The relative lengths of the inner arm segments 46, 48 to the outer arm segments 50, 52 can be selected to angularly contact the tissue when the fastener 30 is deployed, and as illustrated in FIGS. 5-6, the relationship between the proximal and distal rings 32, 36 resembles a cantilevered contact with the inner arm segments 46, 48 actuating to an approximately parallel relationship to the tissue walls 14, 16. The fastener 30 can also optionally include a locking mechanism that is adapted to maintain the position of the proximal and distal arms relative to one another once the fastener is deployed into tissue. One exemplary locking mechanism (not shown) can include at least one hook that is connected to the distal ring of the fastener that can latch to the center ring or the proximal ring upon actuation thereof to maintain the distal ring in an actuated position, and/or another hook that is connected to the proximal ring that can latch to the center ring or the distal ring upon actuation thereof to maintain the proximal ring in an actuated position.

[0034] In use, and in order to effect the delivery of the fastener to tissue, the two slide controls 58, 60 on the handle 54 can be withdrawn proximally to effect actuation of the actuation portion 24, which causes the proximal and distal rings 32, 36 to move from a first resting position to a second actuated position relative to the center ring 34. As shown in FIGS. 4-6, when deployed into tissue 14, 16, the proximal and distal arms 38, 40 hinge outwardly from the longitudinal axis of the fastener 30, creating a hollow rivet or hourglass shape for apposing tissue walls 14, 16. The center ring 34 sits at a tissue junction between the lumens, and the distal and proximal rings 32, 36 can engage the opposed tissues 14, 16. The rings 32-38 can also be latched or locked to one another when actuated, as a result of the locking mechanism, to cause the fastener 30 to be held in the actuated position with bent arms 38, 40 opposing the tissue 14, 16, as shown in FIG. 6. The proximal arms 38 can be staggered, as shown in FIG. 6, from distal arms 40 to create a tortuous path for the compressed tissue. Alternatively, in other embodiments, the arms 38, 40 can be aligned to directly mate to each other.

[0035] In the above embodiment, the proximal ring 36 is stationary with respect to the applier device 10, however the device 10 can also include a third control so that each of the three rings can be positioned independently from the rest, further enhancing the ability to actuate either the distal or the proximal arms 40, 38. Alternatively, the center ring 34 can be stationary with respect to the applier device 10, with controls effective to move the proximal and distal rings 32, 36 inwardly to the center ring 34. Those skilled in the art will appreciate that the applier device can further include a variety of other features known in the art and not disclosed herein, such as, by way of non-limiting example, a catch mechanism for holding the fastener to the device, and in particular to the actuation portion thereof, to prevent accidental deployment.

[0036] While FIGS. 2-6 illustrate one exemplary applier device and fastener that can be used to join a first piece of tissue to a second piece of tissue, a variety of applier devices and fasteners can be used to form an anastomosis in accordance with the method disclosed herein, such as those disclosed in commonly-owned U.S. application Ser. No. 10/675,091, filed Sep. 30, 2003, and entitled "Unfolding Anastomosis Device;" U.S. application Ser. No. 10/674,371, filed Sep. 30, 2003, and entitled "Anastomosis Wire Ring Device;" and U.S. application Ser. No. 10/675,497, filed Sep. 30, 2003, and entitled "Single Lumen Anastomosis Applier for Self-Deploying Fastener," all of which are incorporated by reference herein.

[0037] Applier devices, including portions thereof, can be designed to be disposed after a single use, or they can be designed to be used multiple times. In either case, however, the device can be reconditioned for reuse after at least one use. Reconditioning can include any combination of the steps of disassembly of the device, followed by cleaning or replacement of particular pieces, and subsequent reassembly. By way of example, the applier devices that can be used herein can be reconditioned after the device has been used in a medical procedure. The device can be disassembled, and any number of the particular pieces (e.g., the fasteners, the actuation portion, and the distal tip) can be selectively replaced or removed in any combination. For example, the fasteners can be replaced by adding a new fastener cartridge to the actuation portion or by replacing the actuation portion with a fully loaded actuation portion. Upon cleaning and/or replacement of particular parts, the device can be reassembled for subsequent use either at a reconditioning facility, or by a surgical team immediately prior to a surgical procedure. Those skilled in the art will appreciate that reconditioning of an applier device can utilize a variety of techniques for disassembly, cleaning/replacement, and reassembly. Use of such techniques, and the resulting reconditioned applier device, are all within the scope of the present application.

[0038] One skilled in the art will appreciate further features and advantages of the invention based on the above-described embodiments. Accordingly, the invention is not to be limited by what has been particularly shown and described, except as indicated by the appended claims. All publications and references cited herein are expressly incorporated herein by reference in their entirety.

What is claimed is:

1. A method for joining tissue, comprising:

inserting an applier device having an actuation portion into a first body lumen through a natural body orifice;

forming a first opening in a first piece of tissue within the first lumen and a second opening in a second piece of tissue defining a portion of a second lumen adjacent to the first piece of tissue;

inserting the applier device through the first and second openings such that the actuation portion is between the first and second pieces of tissue; and

deploying a fastener into the first and second pieces of tissue through the actuation portion of the applier device, thereby joining the first and second pieces of tissue to form an anastomosis between the first and second lumens.

2. The method of claim 1, wherein the first and second openings are formed via a laparoscopic surgical procedure.

3. The method of claim 1, wherein the first opening is formed using a cutting member associated with a distal end of the applier device and the second opening is formed using a cutting element that accesses a site of the second opening by a laparoscopic port.

4. The method of claim 1, wherein a distal end of the applier device is used as a marker for forming the first opening.

5. The method of claim 1, further comprising expanding the first and second openings using a tapered distal end of the applier device, such that the applier device can be inserted through the first and second openings.

6. The method of claim 1, further comprising expanding the second opening using at least one grasping element such that the applier device can be inserted through the second opening.

7. The method of claim 1, wherein the actuation portion includes at least one fastener having proximal and distal ring members joined by a connecting element, the proximal and distal ring members each having a plurality of arms extending therefrom that are adapted to engage tissue.

8. The method of claim 7, wherein positioning the actuation portion includes positioning the distal ring member of the fastener such that it is adjacent to the second piece of tissue and positioning the proximal ring member of the fastener such that it is adjacent to the first piece of tissue, such that the connecting element extends between the first and second pieces of tissue.

9. The method of claim 7, wherein deploying the fastener includes moving the plurality of arms of the proximal and distal ring members from a first resting position to a second actuated position such that the plurality of arms engage and hold together the first and second pieces of tissue.

10. The method of claim 9, wherein the plurality of arms of the proximal and distal ring members are independently actuated to engage the first and second pieces of tissue.

11. The method of claim 9, wherein the plurality of arms of the proximal and distal ring members are simultaneously actuated to engage the first and second pieces of tissue.

12. The method of claim 7, wherein deploying the fastener includes disengaging the fastener from a catch located on the actuation portion that holds the fastener to the actuation portion.

13. The method of claim 1, wherein the applier device endoscopically accesses a stomach through an esophagus.

14. The method of claim 1, wherein the first piece of tissue is part of a stomach and the second piece of tissue is part of a jejunum.

15. A method for forming an anastomosis, comprising:

endoscopically inserting an applier device through a natural body orifice, through a lumen and through a first opening formed in a first piece of tissue and a second opening formed in a second piece of tissue;

positioning an actuation portion of the applier device between the first and second pieces of tissue; and

deploying a fastener into the first and second pieces of tissue through the actuation portion of the device to form an anastomosis therebetween.

16. The method of claim 15, wherein the first and second openings are formed via a laparoscopic surgical procedure.

17. The method of claim 15, wherein the first opening is formed using a cutting member associated with a distal end of the applier device and the second opening is formed using a cutting element that accesses a site of the second opening laparoscopically.

18. The method of claim 15, further comprising expanding the first and second openings such that the applier device can be inserted therethrough.

19. The method of claim 15, wherein the actuation portion includes at least one deployable fastener having proximal and distal ring members joined by a connecting element, the proximal and distal ring members each having a plurality of arms extending therefrom that are adapted to engage tissue.

20. The method of claim 19, wherein deploying the fastener includes moving the plurality of grasping arms of the proximal and distal ring members from a resting position to an actuating position such that the plurality of grasping arms engage the first and second pieces of tissue.

* * * * *

| | | | |
|----------------|---|---------|------------|
| 专利名称(译) | 混合胃肠 - 空肠吻合术的方法 | | |
| 公开(公告)号 | US20060217748A1 | 公开(公告)日 | 2006-09-28 |
| 申请号 | US11/277289 | 申请日 | 2006-03-23 |
| [标]申请(专利权)人(译) | 伊西康内外科公司 | | |
| 申请(专利权)人(译) | 爱惜康内镜手术, INC. | | |
| 当前申请(专利权)人(译) | 爱惜康内镜手术, INC. | | |
| [标]发明人 | ORTIZ MARK S | | |
| 发明人 | ORTIZ, MARK S. | | |
| IPC分类号 | A61B17/08 | | |
| CPC分类号 | A61B17/11 A61B17/1114 A61B2017/1103 A61B2017/1139 | | |
| 其他公开文献 | US8211142 | | |
| 外部链接 | Espacenet USPTO | | |

摘要(译)

本文公开了用于将一片组织连接到另一片组织的方法。在一个实施例中，该方法可以包括将具有致动部分的施加器装置通过自然体孔插入第一腔中，在第一腔内的第一组织中形成第一开口，在第二腔中形成第二开口。组织限定与第一组织相邻的第二内腔的一部分，并且将施加器装置插入穿过第一和第二开口，使得致动部分位于第一和第二组织之间。该方法可以进一步包括通过施加器装置的致动部分将紧固件展开到第一和第二组织片中，从而连接第一和第二组织片以在第一和第二内腔之间形成吻合。

