



US 20060178564A1

(19) **United States**

(12) **Patent Application Publication**

Jones et al.

(10) **Pub. No.: US 2006/0178564 A1**

(43) **Pub. Date: Aug. 10, 2006**

(54) **SURGICAL ROTARY CAPTURE INSTRUMENT FOR GASTRIC BAND CLOSING**

on Feb. 4, 2005. Provisional application No. 60/670,111, filed on Apr. 11, 2005.

Publication Classification

(76) Inventors: **Daniel B. Jones**, Wayland, MA (US);
Jerry R. Griffiths, Pembroke, MA (US);
Francis J. Di Francesco, Foxboro, MA (US)

(51) **Int. Cl.**
A61B 1/12 (2006.01)
(52) **U.S. Cl.** **600/159**

Correspondence Address:
AKC PATENTS
215 GROVE ST.
NEWTON, MA 02466 (US)

(57) **ABSTRACT**

An endoscopic surgical rotary capture instrument is used in minimally invasive laparoscopic surgery for closing a gastric band having a buckle end and a free end. The rotary capture instrument includes a pusher end that has a stationary jaw and a movable jaw. The movable jaw is actuated by rotary motion of an inner shaft. The jaws are used to grasp securely and push the tube end of the gastric band after it has been threaded through the buckle end of the band. A hook instrument is used to hold the buckle end securely while the rotary capture instrument is used to push the free end of the gastric band.

(21) Appl. No.: **11/316,194**

(22) Filed: **Dec. 22, 2005**

Related U.S. Application Data

(60) Provisional application No. 60/650,290, filed on Feb. 4, 2005. Provisional application No. 60/650,284, filed

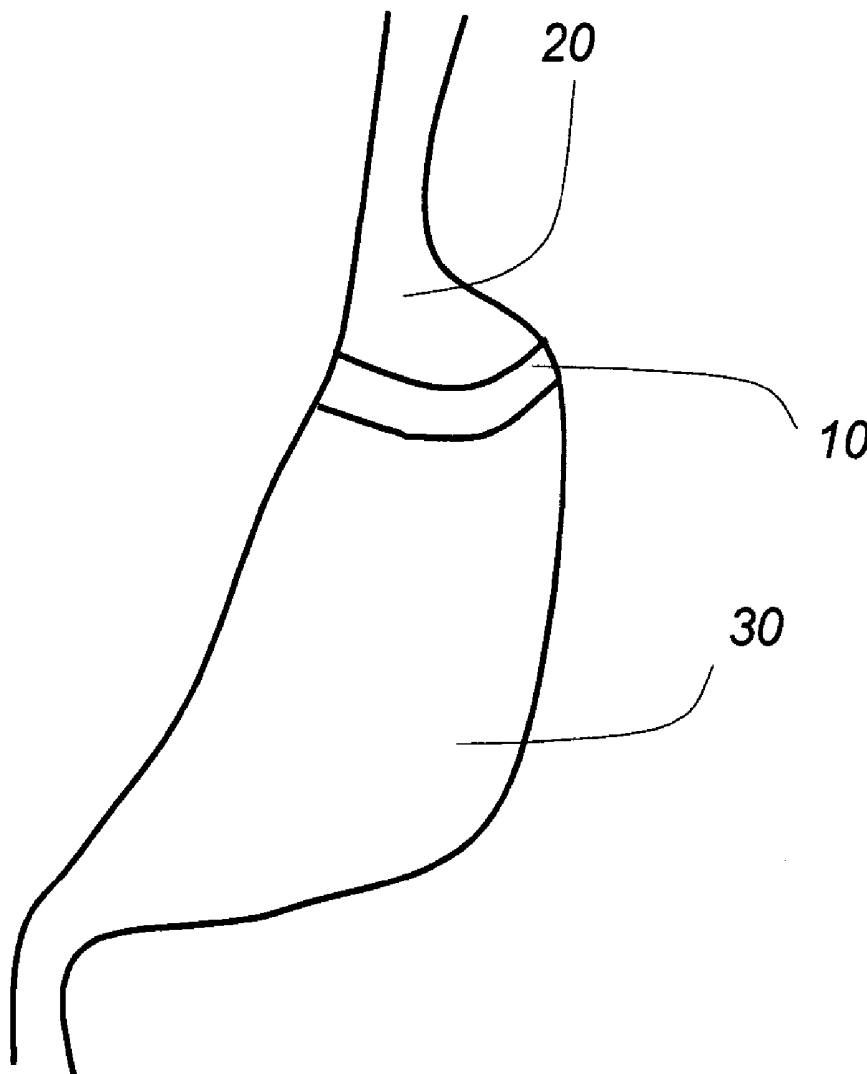

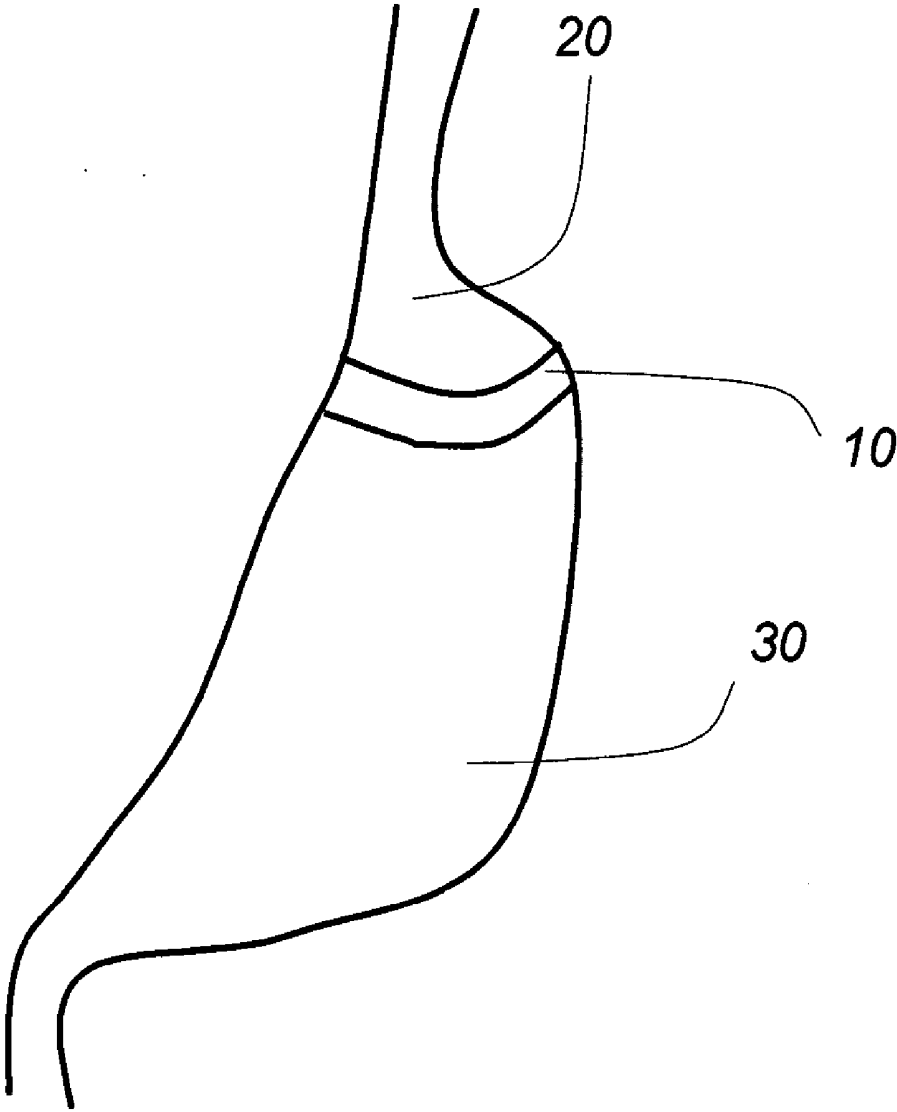

FIG. 1

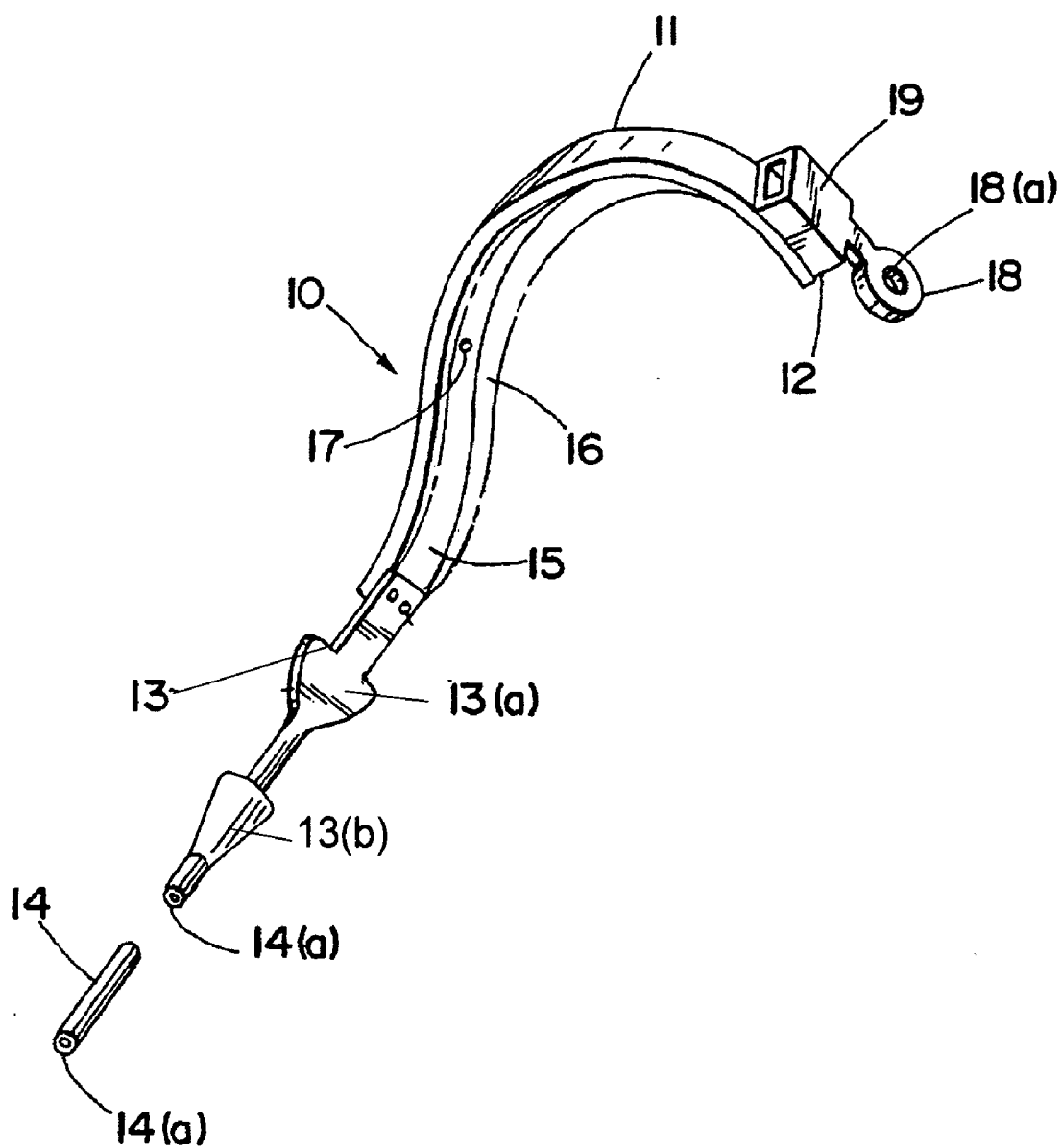

FIG. 2A

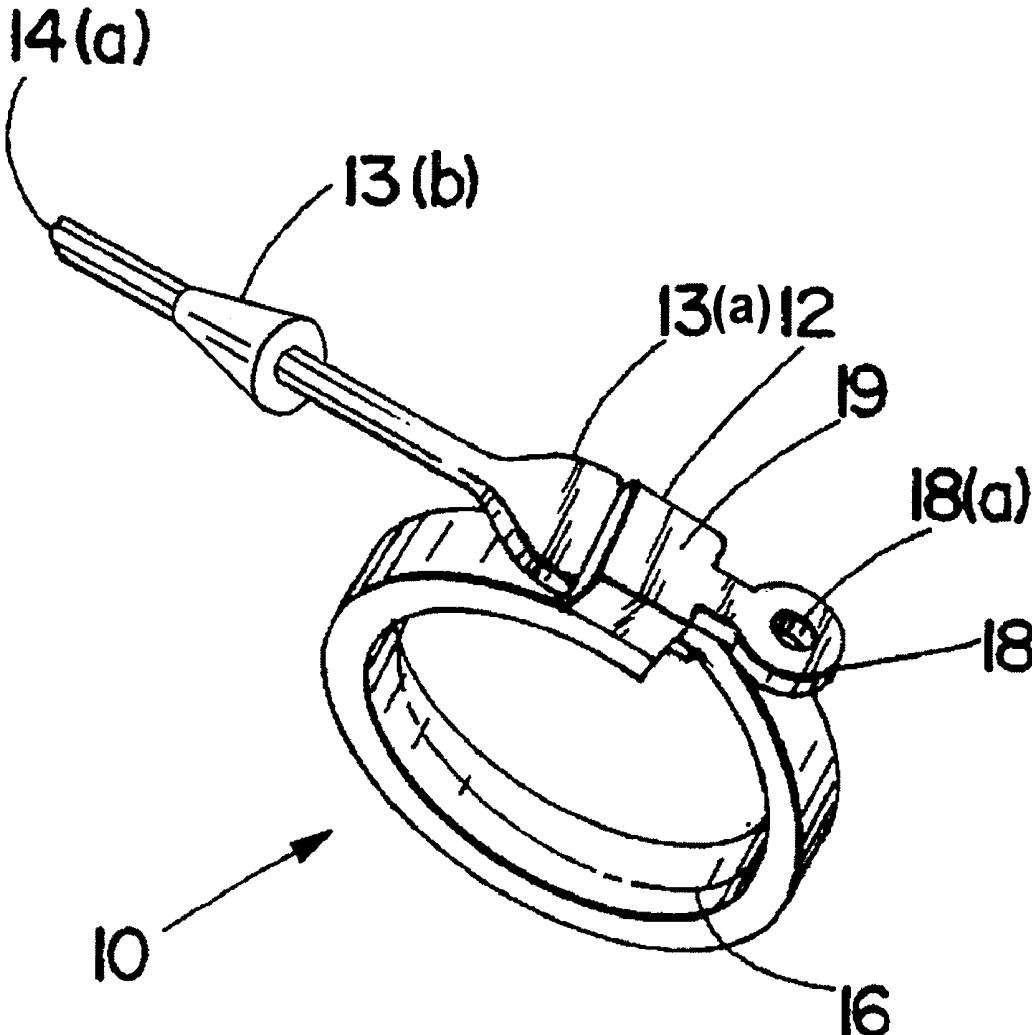

FIG. 2B

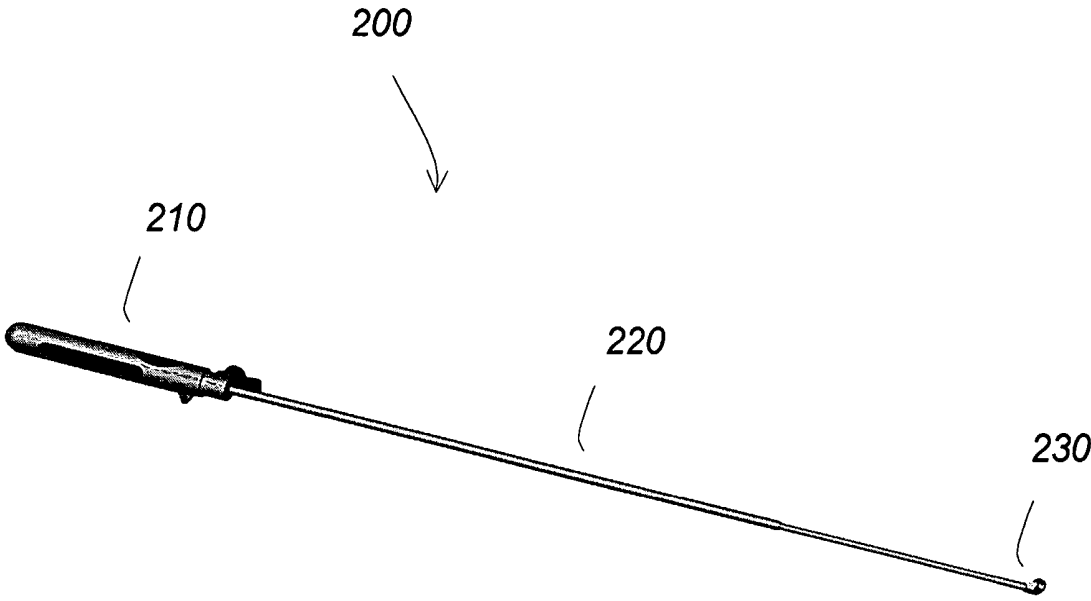

FIG. 3

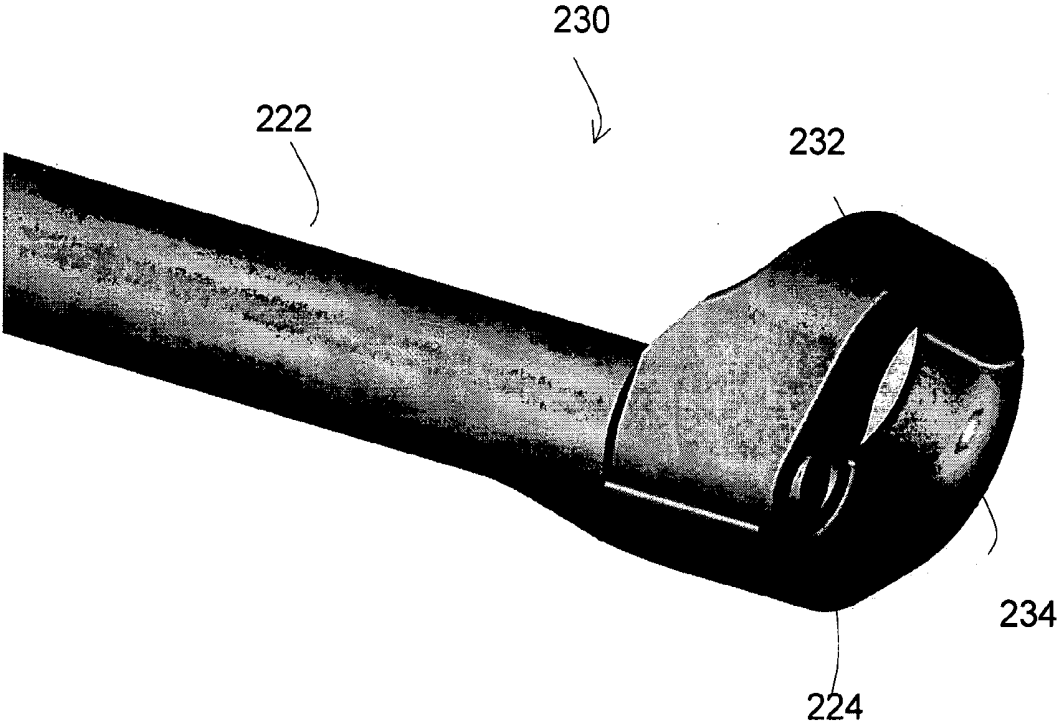

FIG. 4

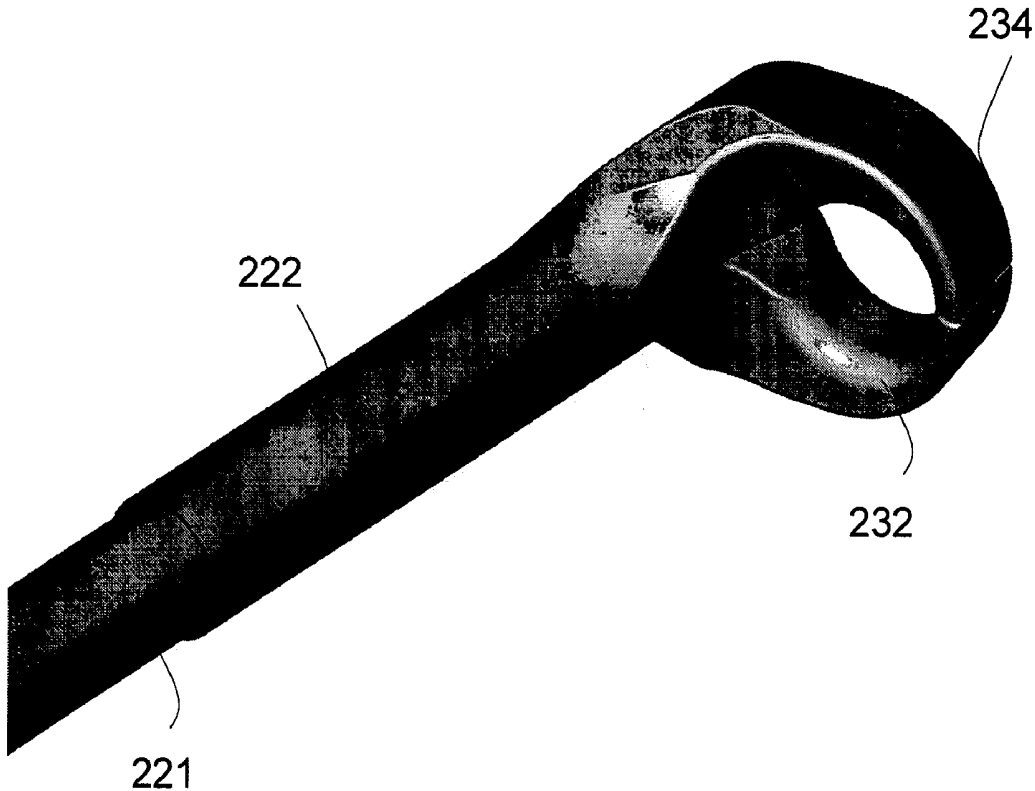

FIG. 5

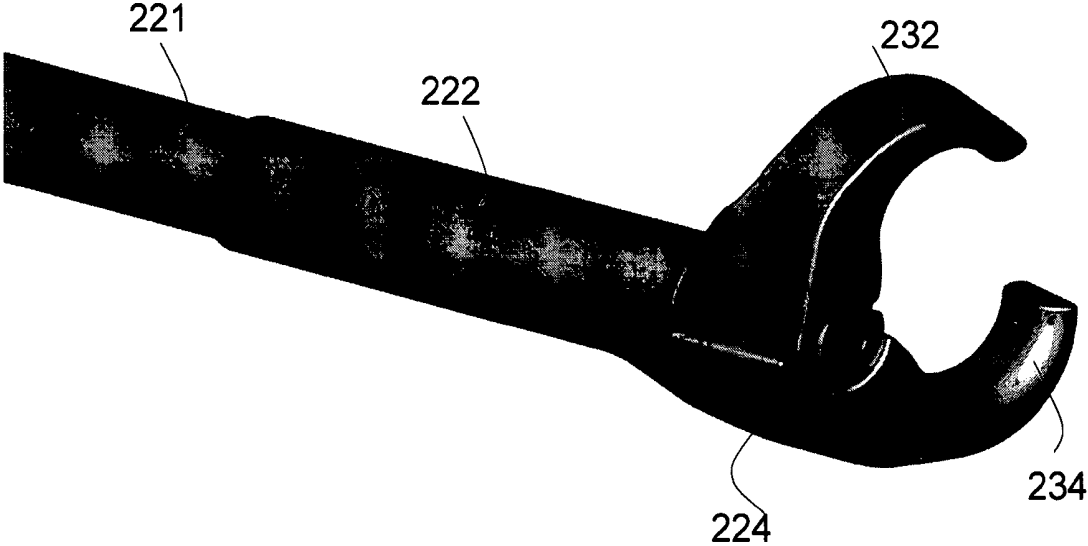

FIG. 6

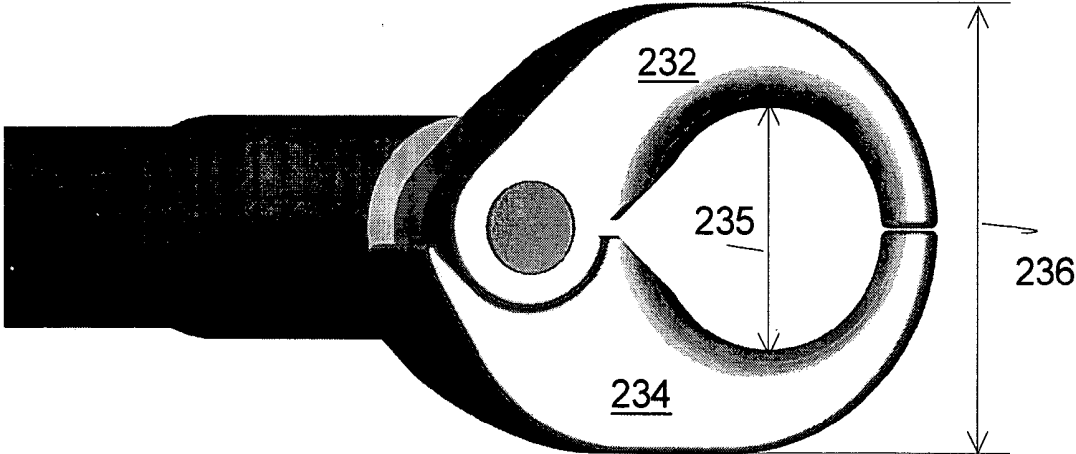

FIG. 7

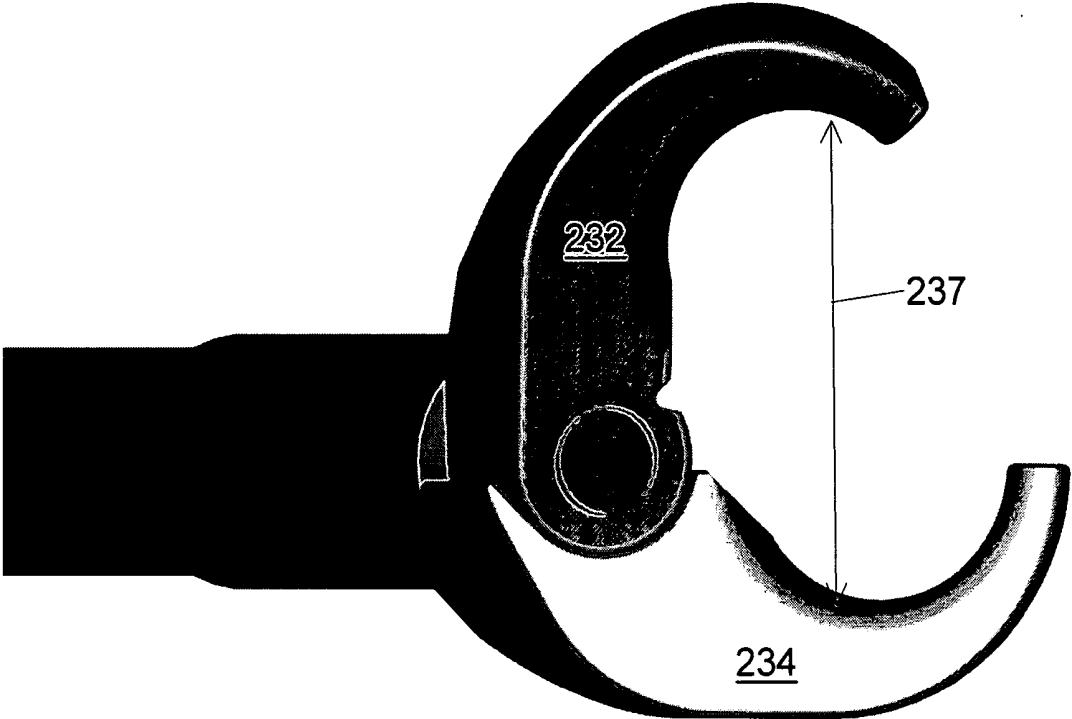

FIG. 8

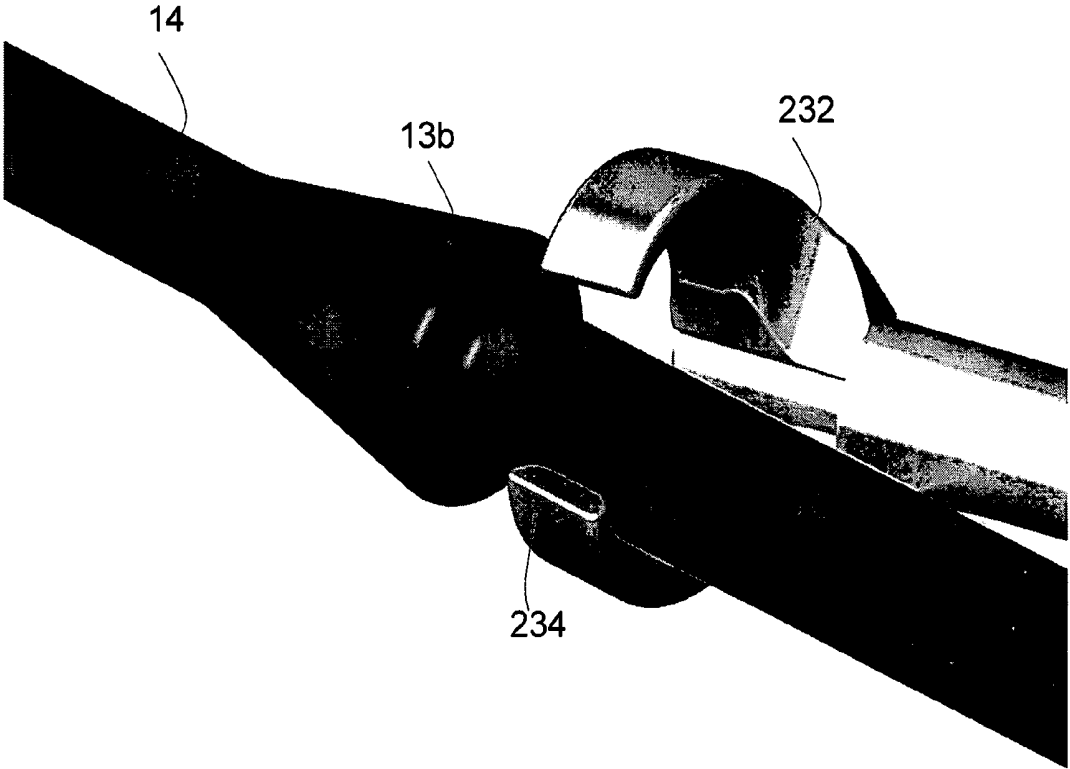

FIG. 9

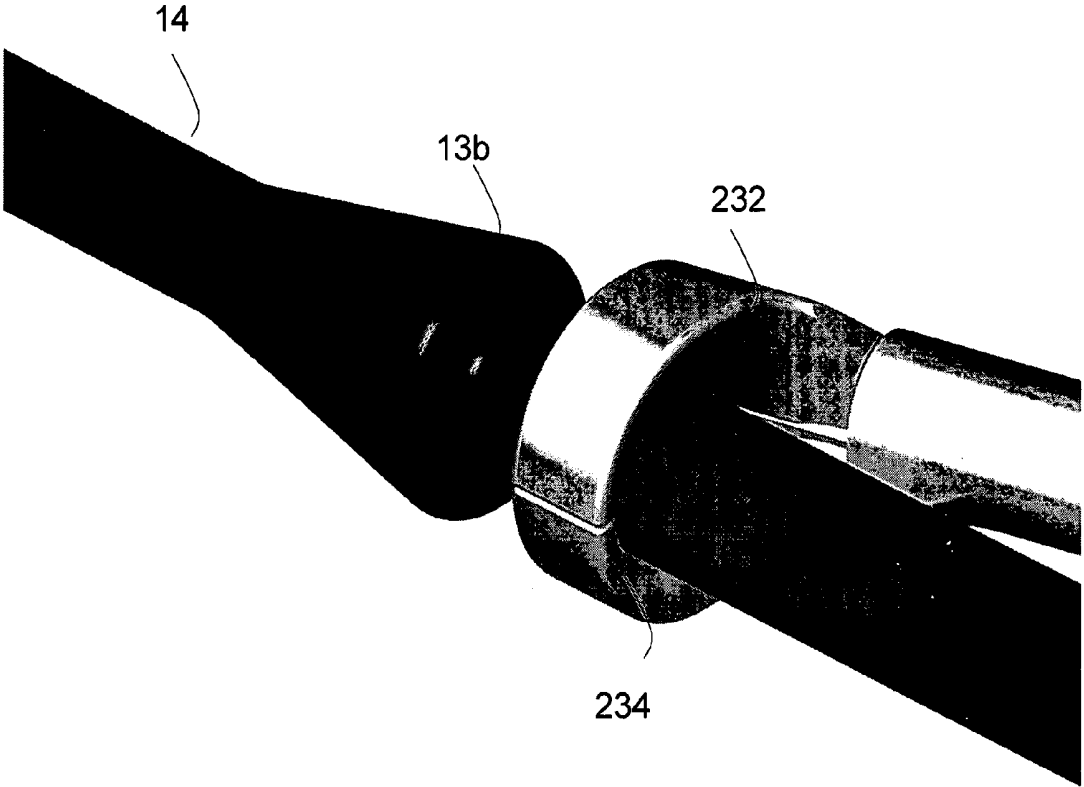

FIG. 10

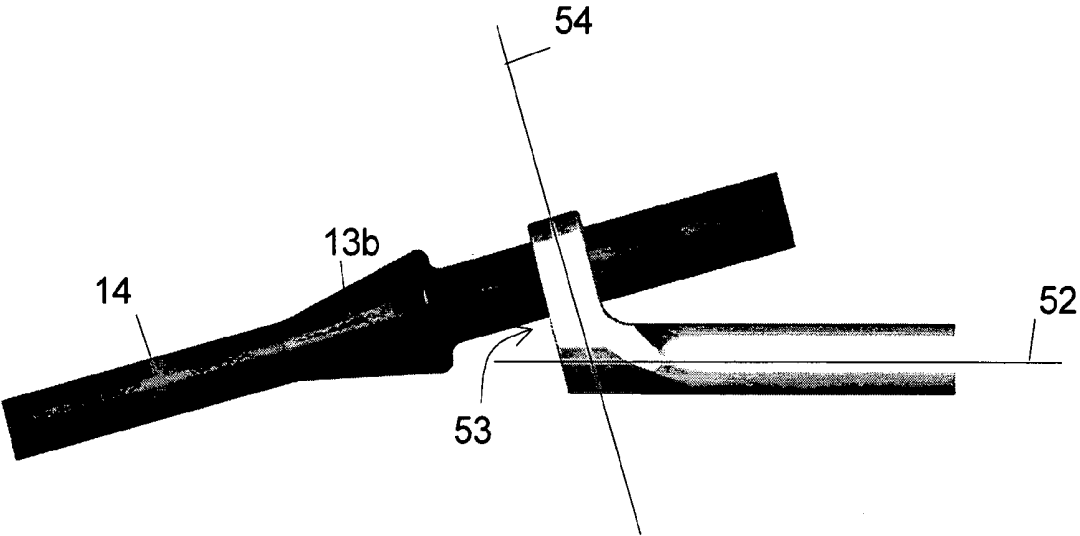

FIG. 11

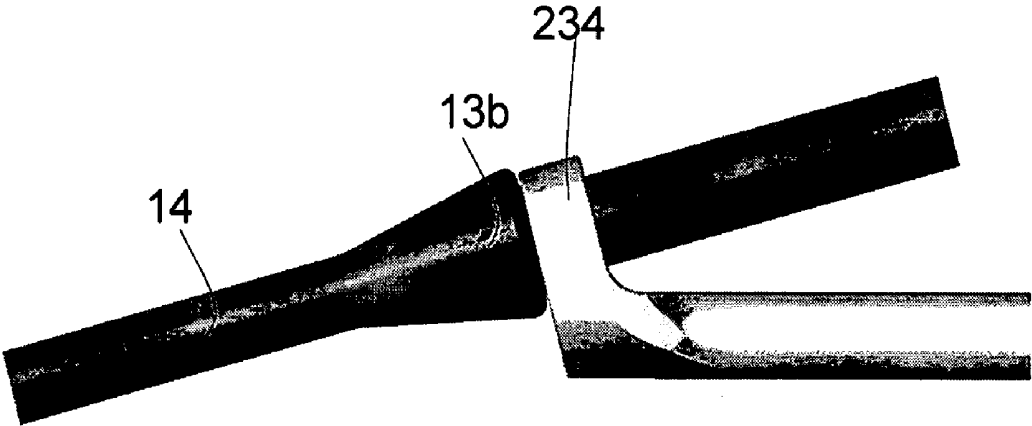

FIG. 12

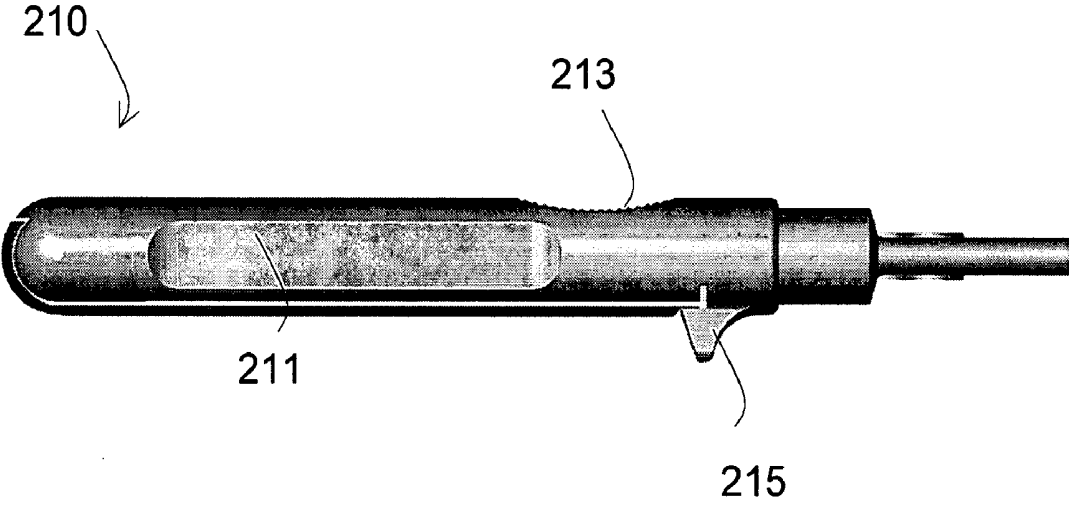

FIG. 13

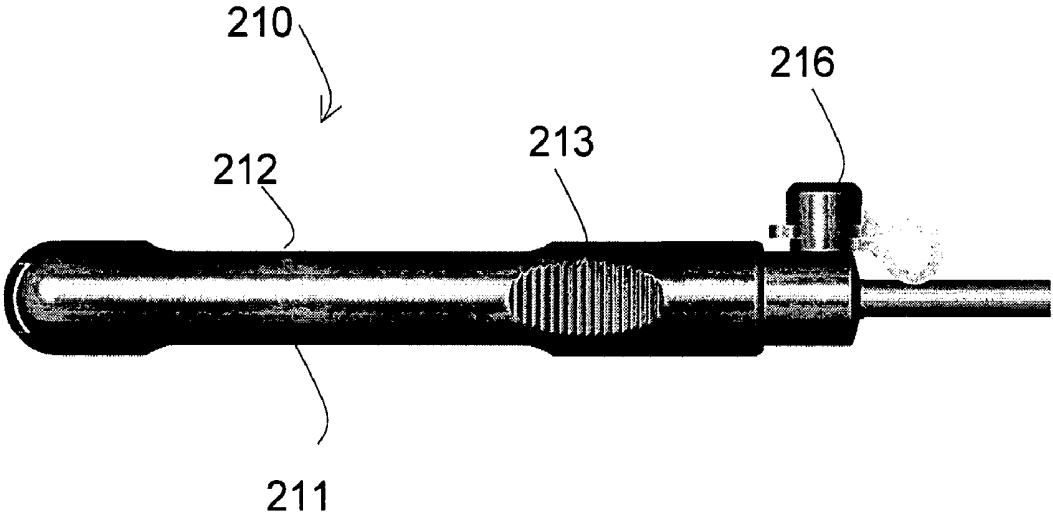

FIG. 14

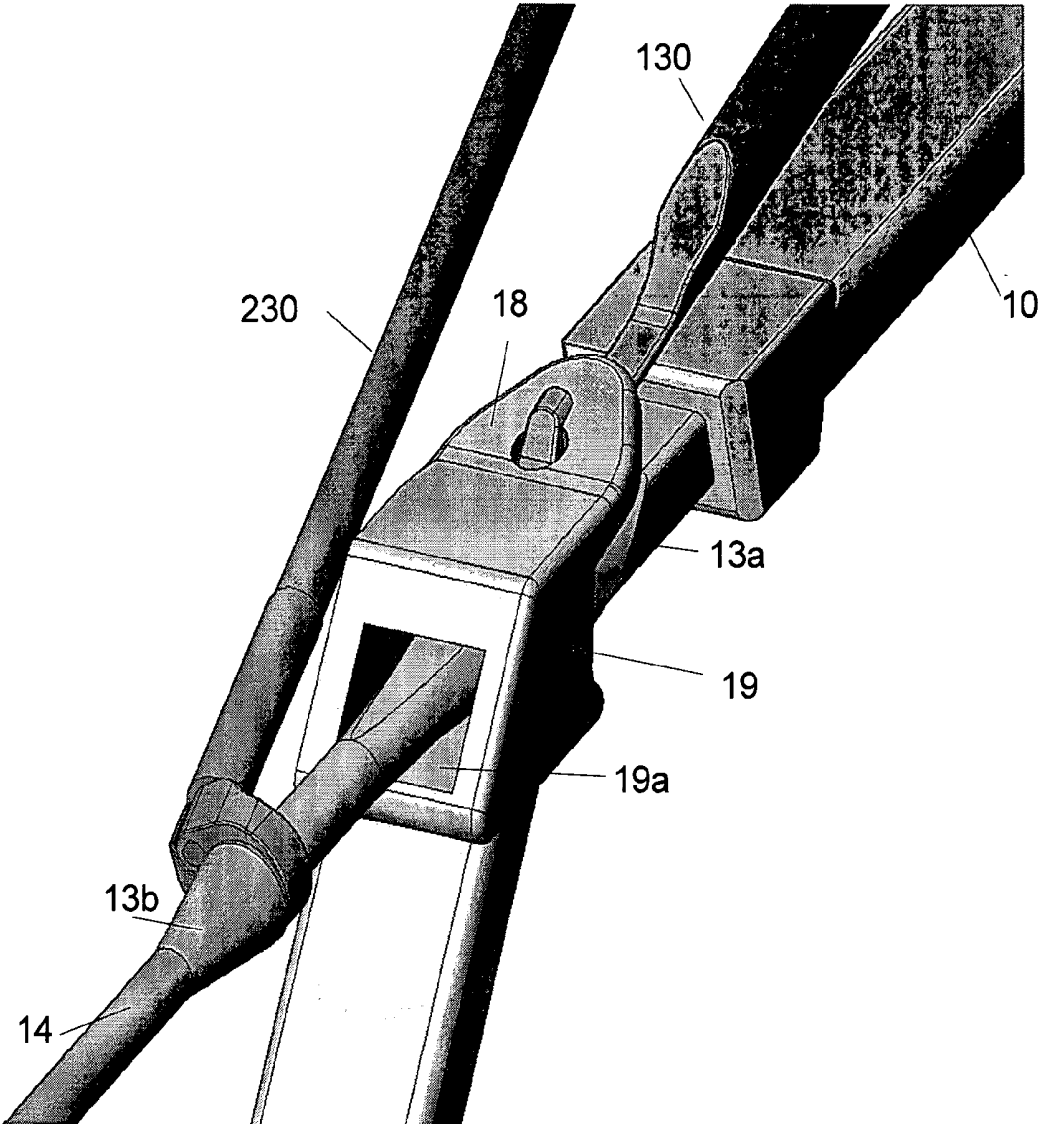

FIG. 15

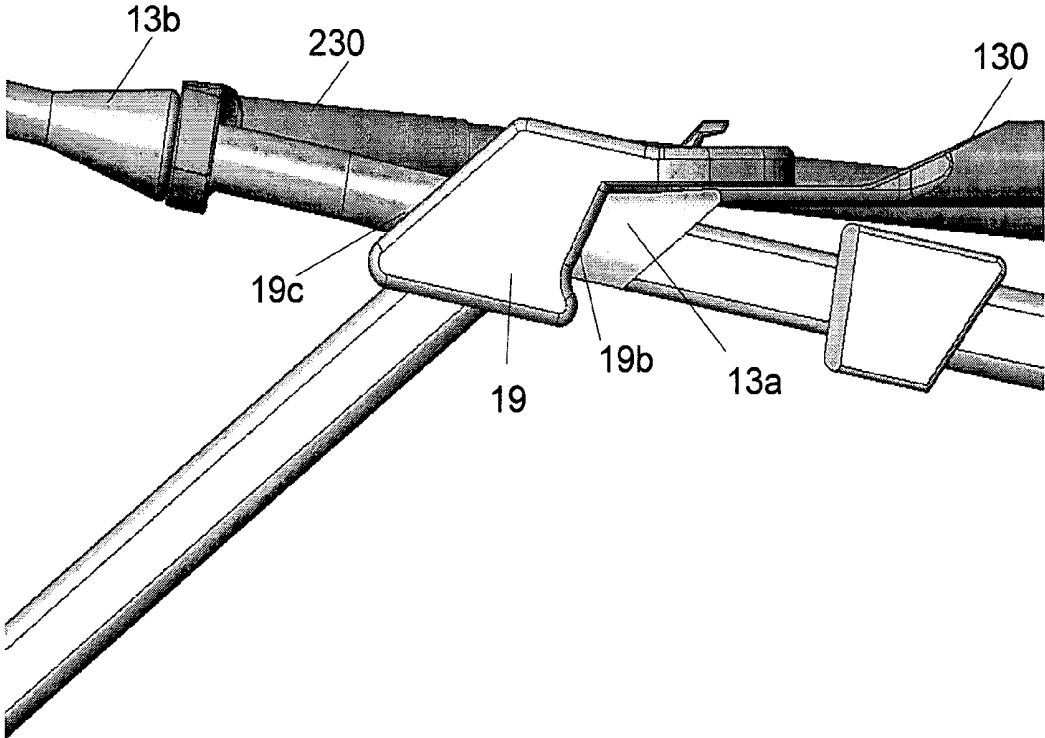

FIG. 16

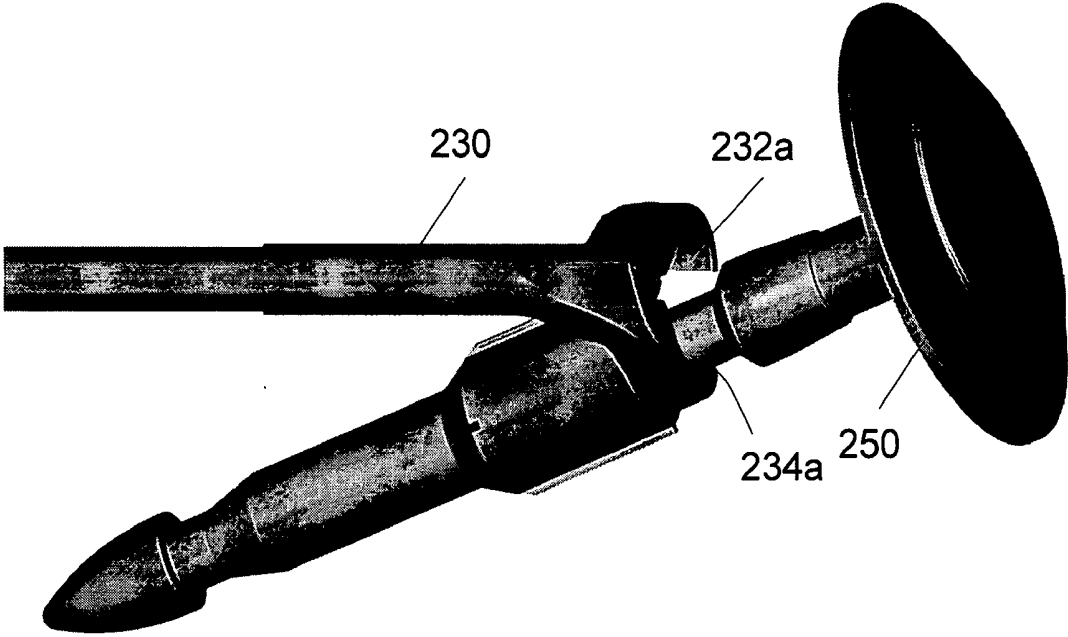

FIG. 17

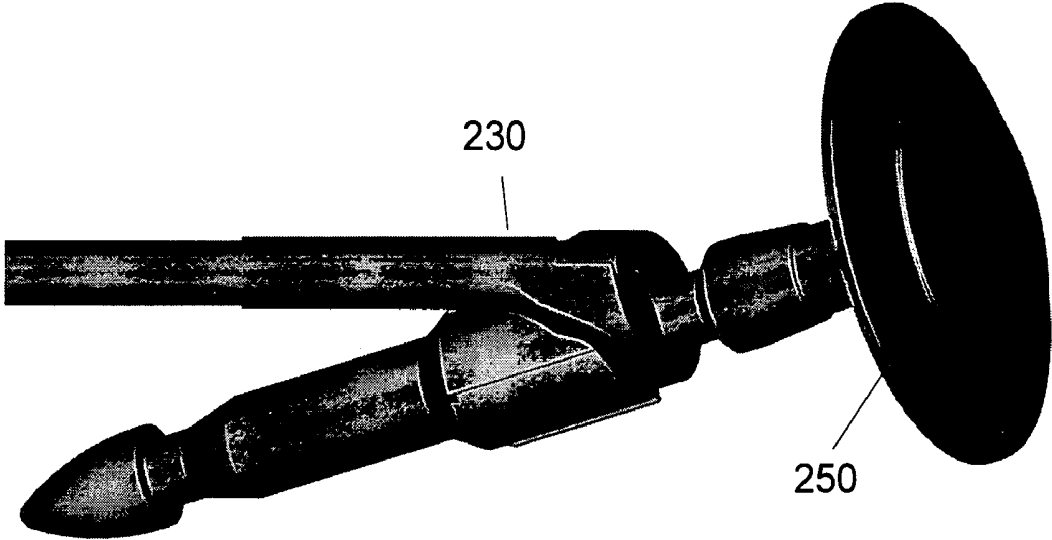

FIG. 18

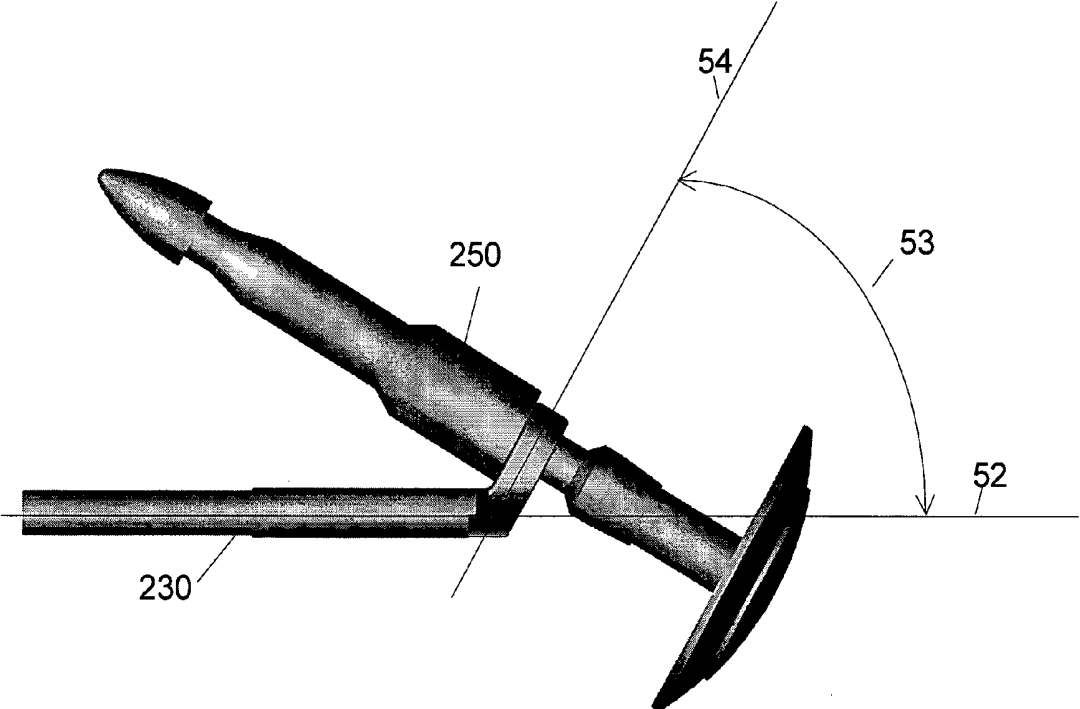

FIG. 19

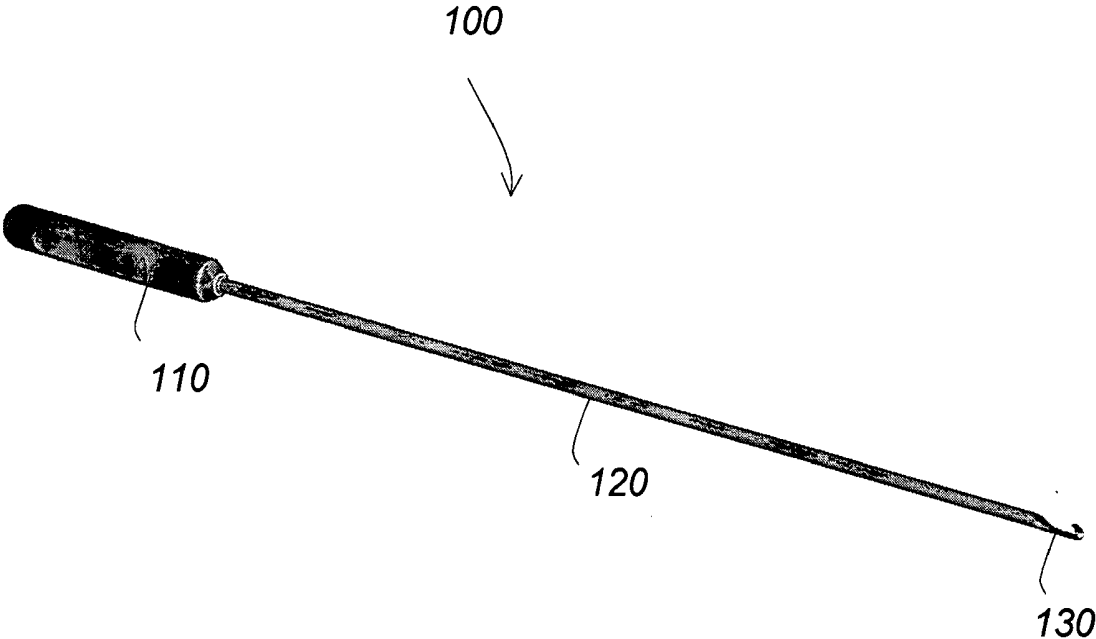

FIG. 20

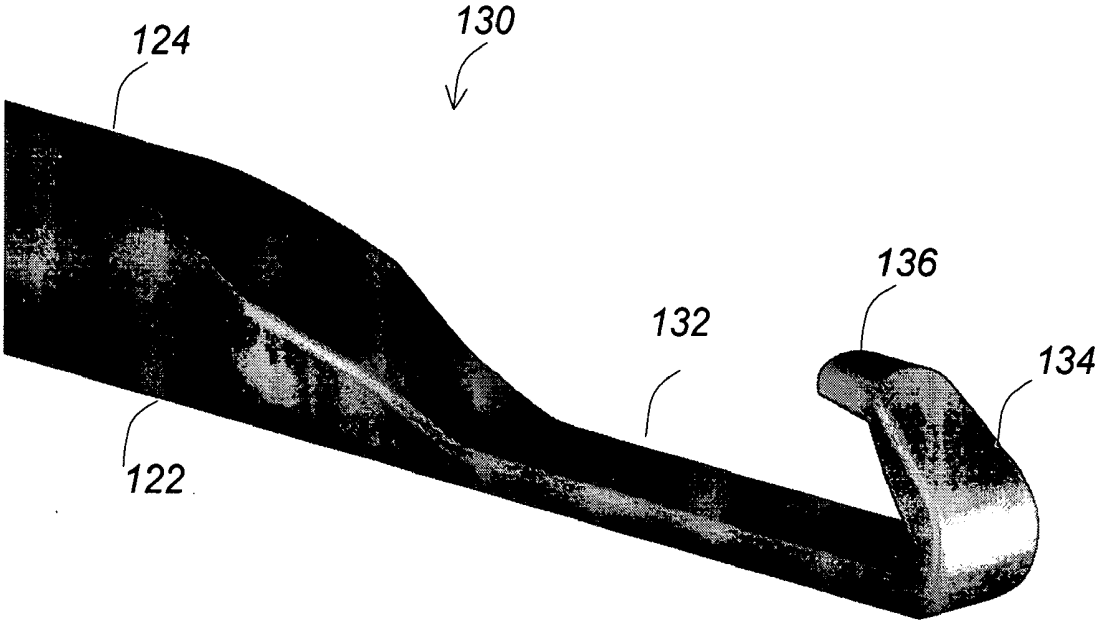

FIG. 21

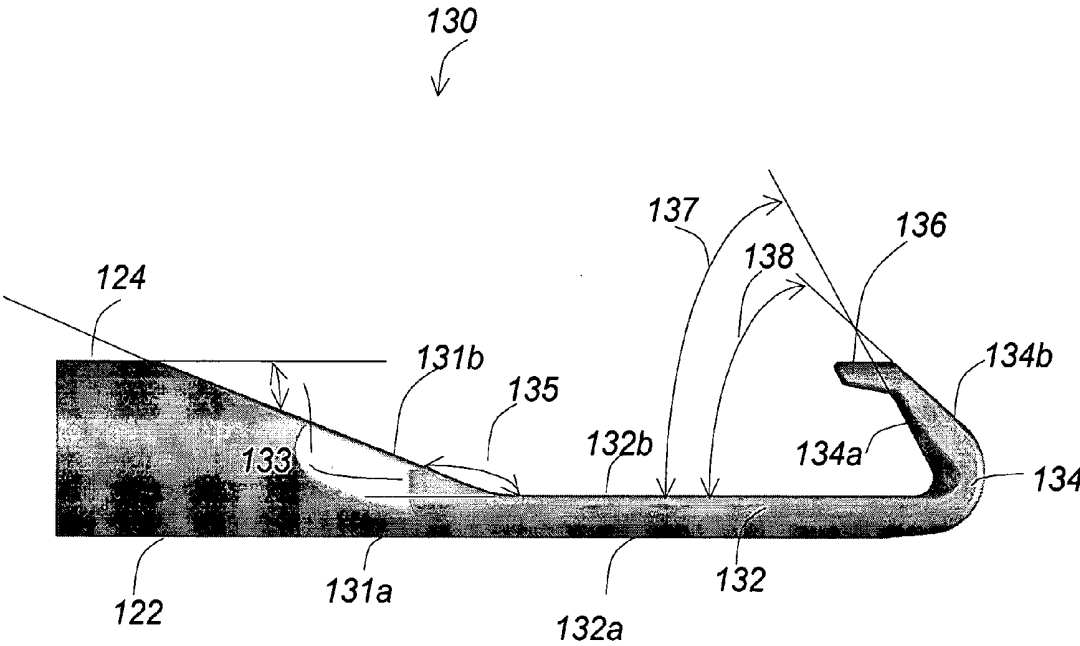

FIG. 22

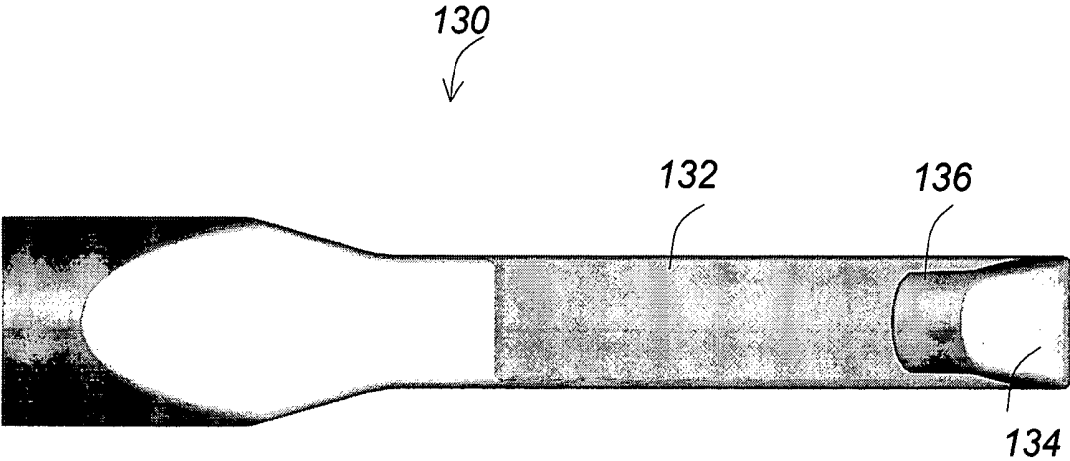

FIG. 23

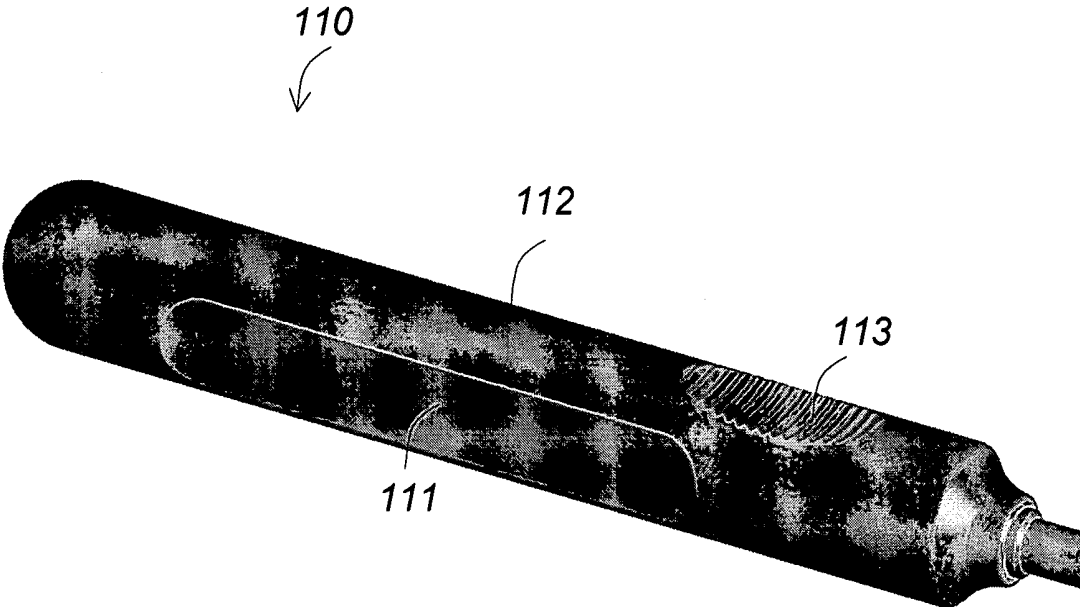

FIG. 24

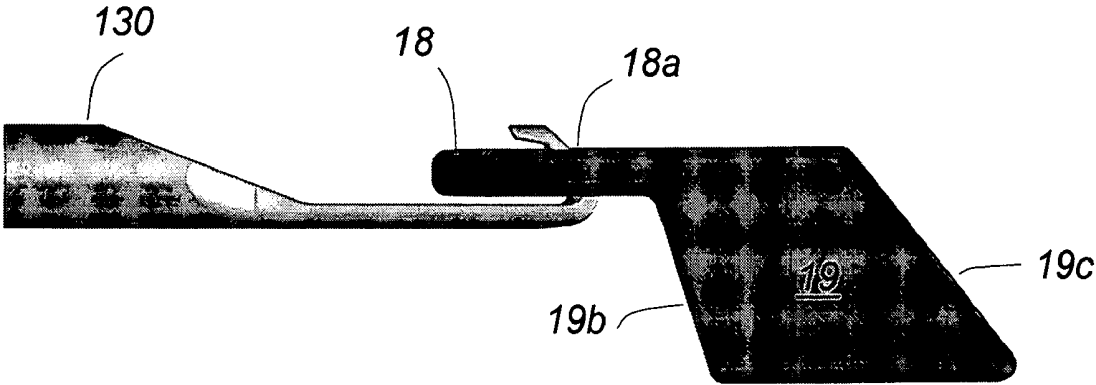

FIG. 25

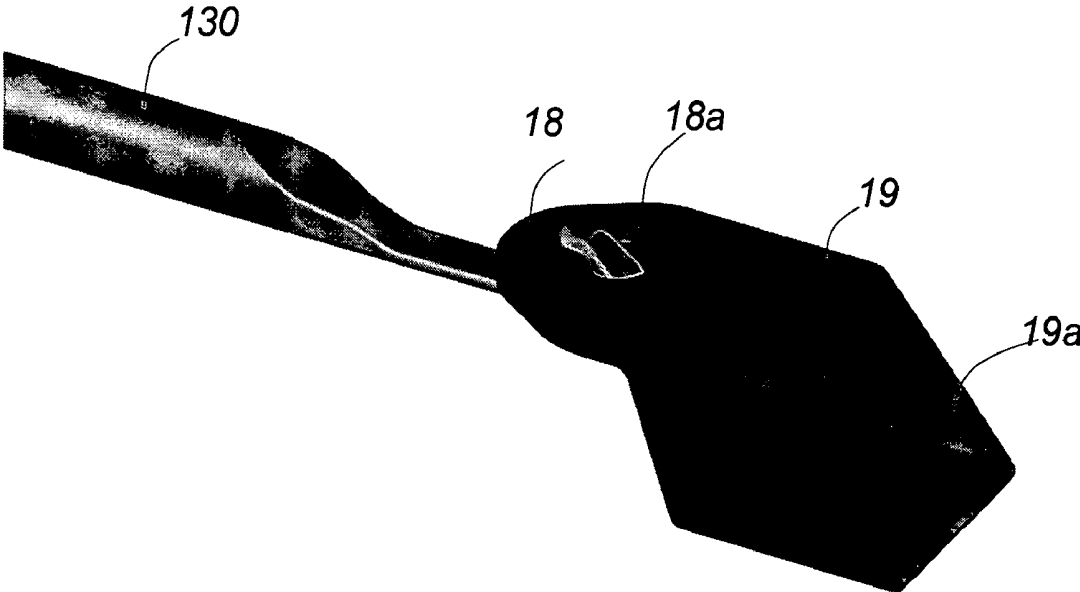

FIG. 26

SURGICAL ROTARY CAPTURE INSTRUMENT FOR GASTRIC BAND CLOSING

CROSS REFERENCE TO RELATED CO-PENDING APPLICATIONS

[0001] This application claims the benefit of U.S. provisional application Ser. No. 60/650,290 filed on Feb. 4, 2005 and entitled SURGICAL ROTARY CAPTURE INSTRUMENT FOR GASTRIC BAND CLOSING which is commonly assigned and the contents of which are expressly incorporated herein by reference.

[0002] This application is also related to U.S. provisional application Ser. No. 60/650,284 filed on Feb. 4, 2005 and entitled SURGICAL HOOK INSTRUMENT FOR GASTRIC BAND CLOSING which is commonly assigned and the contents of which are expressly incorporated herein by reference.

[0003] This application is also related to U.S. provisional application Ser. No. 60/670,111 filed on Apr. 11, 2005 and entitled GASTRIC BAND INSERTION INSTRUMENT which is commonly assigned and the contents of which are expressly incorporated herein by reference.

FIELD OF THE INVENTION

[0004] The present invention relates to an endoscopic surgical rotary capture instrument, and more particularly to a surgical rotary capture instrument used in minimally invasive laparoscopic surgery for closing a gastric band.

BACKGROUND OF THE INVENTION

[0005] One method of controlling the intake of food in an obese person is to place an adjustable restriction band **10** around the upper stomach **20**, shown in **FIG. 1**. This creates a new small stomach pouch in the upper stomach **20** for holding a small amount of food and leaves the larger part of the stomach below the band so the stomach volume available for holding food is reduced. The band also controls the stoma, i.e., stomach outlet, between the upper stomach and the lower stomach **30**. The size of the stoma regulates the flow of food from the upper stomach to the lower stomach. When the stoma is small the patient feels full sooner and has a feeling of satiety that lasts longer.

[0006] One specific type of an adjustable restriction band **10** is the LAP-BAND system manufactured by INAMED Corporation, shown in **FIG. 2A** and **FIG. 2B**. The LAP-BAND system is described in U.S. Pat. No. 5,601,604, the contents of which are incorporated herein by reference. Referring to **FIG. 2A**, the gastric band **10** of the LAP-BAND system includes a body portion **11** a head portion **12** and a tail portion **13**. The head portion **12** has a buckle **19** with a pull tab **18** and the pull tab **18** has a hole **18a** for receiving a post. The tail portion **13** has a tube **14** extending from one end, a triangular shaped member **13a** and a conical shaped barb **13b**. Tube **14** is in communication with an inflatable member **16** of the inner surface **15** of the body portion **11**. The inflatable member **16** is gradually inflated by injecting a saline solution through the tube **14**. The inflated member **16** presses against and constricts the stomach wall underlying the band **10**. This results in decreasing the diameter of the stoma. The amount of the injected solution controls the size of the inflated member **16** and accordingly the diameter of the stoma.

[0007] During a minimally invasive laparoscopic surgical procedure, the tube **14** of the gastric band **10** is pushed through a laparoscopic cannula and is inserted in the patient's abdomen. The gastric band **10** is then placed around the patient's upper stomach and the tail portion **13** is inserted into the buckle **19** thereby forming a ring structure around the upper stomach. The triangular shaped member **13a** of the tail portion **13** interlocks with the buckle **19** and prevents the tube **14** from slipping backwards. The process of inserting the tail portion **13** into the buckle **19** requires simultaneously grasping the buckle **19**, inserting the tube **14** through the buckle conduit **19a** and then pushing the tube **14**. Minimally invasive tools are used for performing these mechanical manipulations needed for tightening the gastric band around the upper stomach.

[0008] A prior art combination tool for grasping the pull tab **18** and pushing the tube **14** is described in U.S. Pat. No. 5,658,298. This prior art tool includes two elongated slidably mounted cylindrical members and a handpiece. At the distal end of the first cylindrical member there is a post extending downwards that is dimensioned to engage the hole **18a** of the tab **18** from the top side, shown in **FIG. 6** of U.S. Pat. No. 5,658,298. The second cylindrical member which is slidably mounted with respect to the first cylindrical member has mounted on its distal end a seat or a fork, shown in **FIG. 3A** of U.S. Pat. No. 5,658,298. This fork is dimensioned to capture protuberances such as the conical barb **13b** at the tube end of the band **10** and push the tube **14** through the buckle conduit **19a**, while the first cylindrical member engages and pulls on the pull tab **18**. Surgeons performing this type of laparoscopic surgery have encountered the problems of the post unintentionally slipping out of the hole **18a** and the fork unintentionally releasing the tube end of the band **10** during the band tightening procedure. This requires regripping the tube end of the band **10** and the tab **18** several times during the procedure which increases both the operation time and the complexity of the operation.

[0009] Accordingly there is a need for an improved grasping and pushing tool used in tightening a band having a buckle end and a free end that does not disengage unintentionally and provides better stability and control during the tightening procedure.

SUMMARY OF THE INVENTION

[0010] In general, in one aspect, the invention features an endoscopic surgical capture tool used in minimally invasive surgery through a cannula for grasping and tightening a ligature band. The ligature band comprises an elongated strap having a buckle end and a distal end, the buckle end having an aperture and a pull tab having a hole thereon. The elongated strap is configured to encircle an internal organ and the distal end is configured to pass through and lockingly engage the aperture thereby tightening the ligature band around the internal organ. The capture tool comprises an elongated shaft having an outer shaft, a rotatable inner shaft, a capture end and a handle. The capture end is configured to engage a protuberance of the distal end and push the distal end after it has been threaded through the aperture. The capture end comprises a stationary jaw and a rotationally movable jaw and the rotationally movable jaw is actuated by rotational motion of the inner shaft.

[0011] Implementations of this aspect of the invention may include one or more of the following features. The

elongated shaft is dimensioned to enter one end, pass through and extend beyond the other end of the cannula. The handle comprises a mechanism for actuating the rotational motion of the inner shaft, thereby actuating the rotationally movable jaw. The mechanism comprises squeezing a handle component. The handle comprises a cylindrical body having first and second side indentations opposite to each other and a thumb indentation on a top surface of the cylindrical body, the thumb indentation being aligned with the rotationally movable jaw. The handle further comprises a latch for keeping the rotationally movable jaw closed. The stationary jaw and the rotationally movable jaw form a circle when closed. The stationary jaw and the rotationally movable jaw comprise rounded edges. The stationary jaw and the rotationally movable jaw comprise a metal, ceramic, polymer, Teflon, alloys, rubber or composites. The stationary jaw and the rotationally movable jaw may have inner surfaces that are spherical, sloped, conical, or have one or more steps or grooves. The internal organ may be stomach, artery, intestines, heart, lung, pancreas, kidney, liver or bone.

[0012] In general, in another aspect, the invention features an endoscopic surgical capture tool used in minimally invasive surgery through a cannula for grasping an organ or another tool having a circular cross-section. The capture tool comprises an elongated shaft having an outer shaft, a rotatable inner shaft, a capture end and a handle. The capture end is configured to engage a protuberance of the organs or the other tool. The capture end comprises a stationary jaw and a rotationally movable jaw and the rotationally movable jaw is actuated by rotational motion of the inner shaft.

[0013] In general, in another aspect, the invention features an endoscopic surgical instrument used in minimally invasive surgery through a cannula for grasping and tightening a ligature band around an internal organ. The ligature band comprises an elongated strap having a buckle end and a distal end, the buckle end having an aperture and a pull tab having a hole thereon. The elongated strap is configured to encircle the internal organ and the distal end is configured to pass through and lockingly engage the aperture thereby tightening the ligature band around the internal organ. The instrument comprises a hook tool configured to engage the hole and pull the pull tab in a first direction while the distal end is threaded through the aperture and pushed opposite to the first direction and a capture tool configured to engage a protuberance of the distal end and push the distal end. The hook tool comprises a hook having a flat portion and a bend portion extending from the flat portion and the flat portion is configured to slide along a flat surface of the pull tab and the bend portion has an inner surface radius matching a radius of the hole. The capture tool comprises a stationary jaw and a rotationally movable jaw and the rotationally movable jaw is actuated by rotational motion of an elongated shaft. The hook tool and the capture tool apply opposing forces on the ligature band for tightening the ligature band around the internal organ.

[0014] In general, in another aspect, the invention features a method for tightening a ligature band around an internal organ via minimally invasive surgery. The method comprises first providing a ligature band comprising an elongated strap having a buckle end and a distal end. The buckle end has an aperture and a pull tab having a hole thereon. Next, inserting the ligature band into a patient's body through a minimally invasive cannula and encircling the

internal organ with the elongated strap. Next, inserting a surgical hook tool through the cannula. The hook tool comprises an elongated shaft having a hook end and a handle. The hook end comprises a flat portion and a bend portion extending from the flat portion and the flat portion is configured to slide along a flat surface of the pull tab and the bend portion has an inner surface radius matching a radius of the hole. Next, engaging the hole with the hook end. Next, inserting a surgical capture tool through the cannula. The capture tool comprises an elongated shaft having an outer shaft, a rotatable inner shaft, a capture end and a handle. The capture end comprises a stationary jaw and a rotationally movable jaw and the rotationally movable jaw is actuated by rotational motion of the inner shaft. Next, engaging a protuberance in the distal end with the capture tool and inserting the distal end through the aperture. Finally, pulling the pull tab in a first direction with the hook tool while pushing the distal end with the capture tool opposite to the first direction.

[0015] Among the advantages of this invention may be one or more of the following. The rotationally movable jaw provides flexibility in capturing an elongated organ, vessel, or other tool having a variety of circular cross-sectional dimensions. The rounded edges of the jaws prevent the jaws from digging and cutting into the organ or tool. The angle between the axis of the elongated shaft and the jaw axis may be varied depending upon the geometry of the organ that needs to be grasped. The inner surfaces of the jaws may be sloped, conical or have one or more steps. These configurations are useful in grasping organs with various cross-sectional geometries. The bend portion of the hook end together with the extension and the flat portion form a C-shaped hook that grasps securely the pull tab. The risk of unintentional disengagement is very low. The extension helps prevent slippage of the hook out of the hole. The inner surface of the bend portion is formed with a radius that matches the inside of the hole in the pull tab. This distributes the pulling force uniformly around the hole and prevents damaging of the pull tab during pulling. The flat portion of the hook end allows the hook end to slide easily underneath or above the pull tab. The capture tool may also be used in non-endoscopic procedures.

[0016] The details of one or more embodiments of the invention are set forth in the accompanying drawings and description below. Other features, objects and advantages of the invention will be apparent from the following description of the preferred embodiments, the drawings and from the claims.

BRIEF DESCRIPTION OF THE DRAWINGS

[0017] Referring to the figures, wherein like numerals represent like parts throughout the several views:

[0018] **FIG. 1** is a side view of a stomach with an adjustable gastric band around the upper part of the stomach;

[0019] **FIG. 2A** is a perspective view of an open LAP-BAND gastric band;

[0020] **FIG. 2B** is the gastric band of **FIG. 2A** in a closed position forming a ring structure;

[0021] **FIG. 3** is a perspective view of the endoscopic rotary capture instrument of this invention;

[0022] FIG. 4-FIG. 8 are perspective views of the pusher end of the instrument of FIG. 3;

[0023] FIG. 9-FIG. 12 are perspective views of the pusher end of the instrument of FIG. 3 engaging and pushing the barb end of the gastric band of FIG. 2A;

[0024] FIG. 13 is side view of the handle of the instrument of FIG. 3;

[0025] FIG. 14 is a top view of the handle of the instrument of FIG. 3;

[0026] FIG. 15-FIG. 16 are perspective views of the pusher end of the instrument of FIG. 3 engaging and pushing the barb end of the gastric band of FIG. 2A through a buckle while a hook instrument is holding the buckle;

[0027] FIG. 17-FIG. 19 are perspective views of another embodiment of the rotary capture instrument of this invention;

[0028] FIG. 20 is a perspective view of the endoscopic hook instrument of this invention;

[0029] FIG. 21 is a perspective view of the hook end of the instrument of FIG. 20;

[0030] FIG. 22 is a side view of the hook of FIG. 21;

[0031] FIG. 23 is a top view of the hook of FIG. 21;

[0032] FIG. 24 is perspective view of the handle of the instrument of FIG. 20;

[0033] FIG. 25 is side view of the hook end of the instrument of FIG. 20 engaging the hole in the tab of the buckle of the gastric band of FIG. 2A; and

[0034] FIG. 26 is a perspective view of the hook end of the instrument of FIG. 20 engaging the hole in the tab of the buckle of the gastric band of FIG. 2A.

DETAILED DESCRIPTION OF THE INVENTION

[0035] Referring to FIG. 3, a surgical rotary capture instrument 200 includes a handle 210, an elongated shaft 220 and a distal end component 230. The handle 210 features a tactile control of the distal end component 230. Referring to FIG. 13-14 the handle 210 features a cylindrical body having a diameter of 15.9 mm and a length of 11.4 cm and it includes two side indentations 211, 212 opposite to each other and a thumb indentation 213 on the top surface. The handle 210 also features a squeeze-to-close, spring-loaded-open design. By squeezing the handle piece 215, a rack actuates a gear, developing a rotary motion that actuates a movable jaw 232 at the end component 230 through a drive shaft 224. The handle 210 also incorporates a latch 216 to keep the instrument in the closed position. The handle actuation could be any number of mechanical means that imparts the rotary motion required.

[0036] The elongated shaft 220 has a cylindrical shape and is dimensioned to fit through a laparoscopic cannula for minimally invasive surgery. In one example, the elongated shaft 220 has a length of 45 cm and a diameter of 5 mm, shown in FIG. 19. Shaft 220 includes an outer shaft 222 and an inner shaft 224. Referring to FIG. 4-12, and FIG. 17-18 the end component 230 includes a stationary jaw 234 and a movable jaw 232. The movable jaw 232 is actuated by rotary

motion of the inner shaft 224. In one example, in closed position jaws 234, 232 form a circle having an inner diameter 235 of 4.8 mm and an outer diameter 236 of 7.6 mm. The front edge of opening 235 is rounded having a radius that matches the corner radius at the rear of barb 13b and the diameter of the tube 14. The rounded edge prevents the jaws from digging in and cutting into the tube 14. In the open position the maximum distance 237 between the movable jaw 232 and the stationary jaw 234 is 10.5 mm. In this embodiment, the angle 53 between the axis 52 of the elongated shaft 220 and the jaw axis 54 is 75 degrees, as shown in FIG. 11 and FIG. 17. This angle 53 may be varied depending upon the geometry of the item that needs to be grasped.

[0037] Referring to FIG. 9-12, jaw 232 is rotated open and jaws 232, 234 are positioned around the tube 14 of the gastric band 10 adjacent to an integral conical shaped barb 13b that is intended to assist in closure. The handle 210 is then actuated causing the movable jaw 232 to rotate closed. This motion captures securely the tube 14. The diameter 240 of the barb 13b is larger than the inner diameter 235 of the closed jaws. The surgeon can then push the closed jaws 232, 234, against the integral barb 13b, thereby causing the tube 14 to move forward.

[0038] Referring to FIG. 15 and FIG. 16, the surgeon threads the tube 14 through side 19b of the buckle conduit 19a, then captures the tube 14 from the other side 19c of the buckle conduit 19a with the jaws 232, 234 and pushes the tube 14 in the direction 50 away from the buckle 19 by pushing the closed jaws 232, 234 against the barb 13b. While pushing tube 14 through the buckle conduit 19a, a hook instrument 100 is used to pull the pull tab 18 of the buckle 19. The triangular shaped member 13a of the tail portion 13 interlocks with the buckle conduit 19a and prevents the tube 14 from slipping backwards. The hook instrument 100 and the rotary capture instrument 200 apply opposing forces on the gastric band 10 in order to cinch and lock the band closed.

[0039] In another embodiment, the rotary capture instrument 200 of this invention is used to capture a vessel or a component, such as the anvil 250 of FIG. 17. In this case the shape of the jaws is selected so that they do not cause any damage to the component 250. This is accomplished by adjusting the angle 53 between the axis of the jaws 54 and the shaft axis 52. In one example the angle 53 is 60 degrees. The shape of the inner jaw surfaces 232a, 234a may also be varied to conform to the specific geometry of the component. 250 For example, the inner surfaces 232a, 234a, may be sloped, conical, have one or more steps or have grooves that assist in grasping the component 250. The opening 235, shown in FIG. 7, is slightly larger than the diameter of the anvil stem. This allows the anvil stem to float slightly for ease of alignment with the mating stapler (not shown). Inner surfaces may also be coated with protective coatings such as Teflon.

[0040] Referring to FIG. 20, a surgical hook instrument 100 includes a handle 110, an elongated shaft 120 and a hook end 130. The handle 110 features a tactile control of the hook end. Referring to FIG. 24 the handle 110 features a cylindrical body having a diameter of 15.9 mm and a length of 11.4 cm and it includes two side indentations 111, 112 opposite to each other and a thumb indentation 113 on the

top surface. The elongated shaft **120** has a cylindrical shape and is dimensioned to fit through a laparoscopic cannula for minimally invasive surgery. In one example, the elongated shaft **120** has a length of 45 cm and a diameter of 5 mm. Referring to **FIG. 21** and **FIG. 22**, the hook end **130** includes an angled portion, a flat portion **130** a bend portion **134** and an extension **136**. The angled portion **131** has a flat bottom surface **131a** and a downwards slopped top surface **131b** forming an angle **133** with the top surface **124** of the elongated shaft **120**. The flat portion **132** has a flat top surface **132b** and a flat bottom surface **132a** that extends continuously from the bottom surface **122** of the elongated shaft **120** and the bottom surface **131a** of the angled portion **131**. The top surface **132b** of the flat portion **132** forms an angle **135** with the top surface **131b** of the angled portion **131**. Angles **133** and **135** are supplementary to each other, i.e., their sum is 180 degrees. In one example, angle **133** is 20 degrees and angle **135** is 160 degrees. In one example, the flat portion **132** has a thickness of 1.3 mm, a width of 3.3 mm and a length of 13.4 mm. The bend portion **134** extends from the flat portion **132** and is bend upwards and towards the handle **110**. The inner surface **134a** of the bend portion **134** forms an angle **137** with the top surface **132b** of the flat portion **132**. Inner surface **134a** is formed with a radius that matches the inside of the hole **18a** in the pull tab **18**. This distributes the pulling force uniformly around the hole and prevents damaging of the pull tab **18** during pulling. The outer surface **134b** of the bend portion **134** is curved and forms an angle **138** with the top surface **132b** of the flat portion **132**. In one example angles **137** and **138** are 40 and 60 degrees, respectively. Extension **136** extends from the bend portion **134**, points towards the handle **110** and is parallel to the flat portion **132**. In one example it has a length of 2.0 mm and a thickness of 0.8 mm. Extension **136** helps prevent slippage of the hook out of the hole **18a**. The inner surface of **136** forms an angle with the inner surface **134a**, which facilitates pickup of the hole **18a** by the hook **130**.

[0041] Referring to **FIG. 25** and **FIG. 26**, the flat portion **132** of the hook end **130** is placed underneath the pull tab **18** of the gastric band buckle and the bend portion is inserted into the hole **18a** thereby engaging the pull tab. The bend portion **134** together with the extension **136** and the flat portion **132** form a C-shaped hook that grasps securely the pull tab **18**. The risk of unintentional disengagement is very low. While holding the buckle end **19** securely with the hook end **130** a rotary capture instrument **200** (shown in **FIG. 15**) is used to capture and push the tube **14** of the gastric band **10** through the buckle conduit **19a**. The triangular shaped member **13a** of the tail portion **13** interlocks with the buckle conduit **19a** and prevents the tube **14** from slipping backwards. The hook instrument **100** and the rotary capture instrument **200** apply opposing forces on the gastric band **10** in order to cinch and lock the band closed.

[0042] Several embodiments of the present invention have been described. Nevertheless, it will be understood that various modifications may be made without departing from the spirit and scope of the invention. Accordingly, other embodiments are within the scope of the following claims.

What is claimed is:

1. An endoscopic surgical capture tool used in minimally invasive surgery for grasping and tightening a ligature band, wherein said ligature band comprises an elongated strap having a buckle end and a distal end, said buckle end having

an aperture and a pull tab having a hole thereon and wherein said elongated strap is configured to encircle an internal organ and said distal end is configured to pass through and lockingly engage said aperture thereby tightening said ligature band around said internal organ, the capture tool comprising:

an elongated shaft comprising an outer shaft, a rotatable inner shaft, a capture end and a handle, wherein said capture end is configured to engage a protuberance of said distal end and push said distal end after it has been threaded through said aperture; and

wherein said capture end comprises a stationary jaw and a rotationally movable jaw and wherein said rotationally movable jaw is actuated by rotational motion of said inner shaft.

2. The endoscopic surgical capture tool of claim 1 wherein said elongated shaft is inserted through a cannula into a patient's body and is dimensioned to enter one end, pass through and extend beyond the other end of said cannula.

3. The endoscopic surgical capture tool of claim 1 wherein said handle comprises a mechanism for actuating said rotational motion of said inner shaft, thereby actuating said rotationally movable jaw.

4. The endoscopic surgical capture tool of claim 3 wherein said mechanism comprises squeezing a handle component.

5. The endoscopic surgical capture tool of claim 3 wherein said handle comprises a cylindrical body having first and second side indentations opposite to each other and a thumb indentation on a top surface of said cylindrical body, said thumb indentation being aligned with said rotationally movable jaw.

6. The endoscopic surgical capture tool of claim 3 wherein said handle further comprises a latch for keeping said rotationally movable jaw closed.

7. The endoscopic surgical capture tool of claim 1 wherein said stationary jaw and said rotationally movable jaw form a circle when closed.

8. The endoscopic surgical capture tool of claim 1 wherein said stationary jaw and said rotationally movable jaw comprise rounded edges.

9. The endoscopic surgical capture tool of claim 1 wherein said stationary jaw and said rotationally movable jaw comprise a material selected from a group consisting of metal, ceramic, polymer, Teflon, alloys, rubber and composites.

10. The endoscopic surgical capture tool of claim 1 wherein said stationary jaw and said rotationally movable jaw comprise inner surfaces selected from a group consisting of spherical, slopped, conical, having one or more steps and having one or more grooves.

11. The endoscopic surgical tool of claim 1 wherein said internal organ is selected from a group consisting of stomach, artery, intestines, heart, lung, pancreas, kidney, bone and liver.

12. An endoscopic surgical capture tool used in minimally invasive surgery for grasping an organ or another tool having a circular cross-section, the capture tool comprising:

an elongated shaft comprising an outer shaft, a rotatable inner shaft, a capture end and a handle, wherein said capture end is configured to engage a protuberance of said organs or other tools; and

wherein said capture end comprises a stationary jaw and a rotationally movable jaw and wherein said rotationally movable jaw is actuated by rotational motion of said inner shaft.

13. The endoscopic surgical capture tool of claim 12 wherein said elongated shaft is inserted through a cannula into a patient's body and is dimensioned to enter one end, pass through and extend beyond the other end of said cannula.

14. The endoscopic surgical capture tool of claim 12 wherein said handle comprises a mechanism for actuating said rotational motion of said inner shaft, and thereby actuating said rotationally movable jaw.

15. The endoscopic surgical capture tool of claim 14 wherein said mechanism comprises squeezing a handle component.

16. The endoscopic surgical capture tool of claim 14 wherein said handle comprises a cylindrical body having first and second side indentations opposite to each other and a thumb indentation on a top surface of said cylindrical body, said thumb indentation being aligned with said rotationally movable jaw.

17. The endoscopic surgical capture tool of claim 14 wherein said handle further comprises a latch for keeping said rotationally movable jaw closed.

18. The endoscopic surgical capture tool of claim 12 wherein said stationary jaw and said rotationally movable jaw form a circle when closed.

19. The endoscopic surgical capture tool of claim 12 wherein said stationary jaw and said rotationally movable jaw comprise rounded edges.

20. The endoscopic surgical capture tool of claim 12 wherein said stationary jaw and said rotationally movable jaw comprise a material selected from a group consisting of metal, ceramic, polymer, Teflon, alloys, rubber and composites.

21. The endoscopic surgical capture tool of claim 12 wherein said stationary jaw and said rotationally movable jaw comprise inner surfaces selected from a group consisting of spherical, sloped, conical, having one or more steps and having one or more grooves.

22. An endoscopic surgical instrument used in minimally invasive surgery for grasping and tightening a ligature band around an internal organ, wherein said ligature band comprises an elongated strap having a buckle end and a distal end, said buckle end having an aperture and a pull tab having a hole thereon and wherein said elongated strap is configured to encircle said internal organ and said distal end is configured to pass through and lockingly engage said aperture thereby tightening said ligature band around said internal organ, the instrument comprising:

a hook tool configured to engage said hole and pull said pull tab in a first direction while said distal end is pushed through said aperture opposite to said first direction;

a capture tool configured to engage a protuberance of said distal end and push said distal end after it has been threaded through said aperture;

wherein said hook tool comprises a hook having a flat portion and a bend portion extending from said flat portion and wherein said flat portion is configured to slide along a flat surface of said pull tab and said bend portion has an inner surface radius matching a radius of said hole; and

wherein said capture tool comprises a stationary jaw and a rotationally movable jaw and wherein said rotationally movable jaw is actuated by rotational motion of an elongated shaft.

23. The endoscopic surgical instrument of claim 22 wherein said hook tool and said capture tool apply opposing forces on said ligature band for tightening said ligature band around said internal organ.

24. A method for tightening a ligature band around an internal organ via minimally invasive surgery comprising:

providing a ligature band comprising an elongated strap having a buckle end and a distal end, wherein said buckle end has an aperture and a pull tab having a hole thereon;

inserting said ligature band into a patient's body through a minimally invasive cannula and encircling said internal organ with said elongated strap;

inserting a surgical hook tool through said cannula, wherein said hook tool comprises an elongated shaft having a hook end and a handle and wherein said hook end comprises a flat portion and a bend portion extending from said flat portion and wherein said flat portion is configured to slide along a flat surface of said pull tab and said bend portion has an inner surface radius matching a radius of said hole;

engaging said hole with said hook end;

inserting a surgical capture tool through said cannula, wherein said capture tool comprises an elongated shaft comprising an outer shaft, a rotatable inner shaft, a capture end and a handle, and wherein said capture end comprises a stationary jaw and a rotationally movable jaw and wherein said rotationally movable jaw is actuated by rotational motion of said inner shaft

engaging a protuberance in said distal end with said capture tool and inserting said distal end through said aperture; and

pulling said pull tab in a first direction with said hook tool while pushing said distal end through said aperture with said capture tool opposite to said first direction.

* * * * *

专利名称(译)	用于胃束带闭合的手术旋转捕获仪器		
公开(公告)号	US20060178564A1	公开(公告)日	2006-08-10
申请号	US11/316194	申请日	2005-12-22
[标]申请(专利权)人(译)	JONES DANIEL B 格里菲思杰里 - [R DI FRANCESCO FRANCIS J		
申请(专利权)人(译)	JONES DANIEL B 格里菲思杰里 - [R DI FRANCESCO FRANCIS J		
当前申请(专利权)人(译)	对称医疗制造, INC.		
[标]发明人	JONES DANIEL B GRIFFITHS JERRY R DI FRANCESCO FRANCIS J		
发明人	JONES, DANIEL B. GRIFFITHS, JERRY R. DI FRANCESCO, FRANCIS J.		
IPC分类号	A61B1/12		
CPC分类号	A61B17/068 A61B17/115 A61B17/282 A61F5/0003 A61F5/005 A61F5/0089 A61B17/12 A61B17/12009 A61B17/12013 A61B2017/12018		
优先权	60/670111 2005-04-11 US 60/650284 2005-02-04 US 60/650290 2005-02-04 US		
外部链接	Espacenet USPTO		

摘要(译)

内窥镜手术旋转捕获器械用于微创腹腔镜手术中，用于闭合具有带扣端的自由端的胃束带。旋转捕获仪器包括推动器端部，该推动器端部具有固定钳口和可动钳口。可动夹爪由内轴的旋转运动致动。钳口用于在带子穿过带子的带扣端之后牢固地啮气并推动胃束带的管端。钩子器械用于牢固地保持带扣端部，同时旋转捕获器械用于推动胃束带的自由端。

