



US009375213B2

(12) **United States Patent**
Forsell

(10) **Patent No.:** **US 9,375,213 B2**
(45) **Date of Patent:** **Jun. 28, 2016**

(54) **METHODS AND INSTRUMENTS FOR TREATING OBESITY**

(76) Inventor: **Peter Forsell**, Zug (CH)

(*) Notice: Subject to any disclaimer, the term of this patent is extended or adjusted under 35 U.S.C. 154(b) by 526 days.

(21) Appl. No.: **12/864,718**

(22) PCT Filed: **Jan. 29, 2009**

(86) PCT No.: **PCT/SE2009/000049**

§ 371 (c)(1),
(2), (4) Date: **Jul. 27, 2010**

(87) PCT Pub. No.: **WO2009/096864**

PCT Pub. Date: **Aug. 6, 2009**

(65) **Prior Publication Data**

US 2010/0312047 A1 Dec. 9, 2010

(30) **Foreign Application Priority Data**

Oct. 10, 2008 (SE) 0802138

(51) **Int. Cl.**

A61M 29/00 (2006.01)

A61B 17/08 (2006.01)

(Continued)

(52) **U.S. Cl.**

CPC . **A61B 17/08** (2013.01); **A61B 1/04** (2013.01);
A61B 1/2736 (2013.01);

(Continued)

(58) **Field of Classification Search**

CPC **A61B 17/00**; **A61B 17/12136**; **A61B 17/12186**; **A61B 17/1219**; **A61B 17/3415**; **A61B 2019/4878**; **A61B 2017/0028**; **A61B 2017/00818**; **A61B 17/00827**; **A61B 2018/00285**; **A61B 17/00823**; **A61F 5/0076**; **A61F 5/003**; **A61F 5/0036**; **A61F 5/0089**; **A61F 5/0059**; **A61F 5/0046**; **A61F 5/004**; **A61F 5/0026**; **A61F 5/0033**; **A61F 5/0043**;

A61F 5/005; A61F 5/0053; A61F 5/0056;
A61F 5/0069; A61F 5/0073; A61F 5/0086;
A61F 5/0003; A61F 5/0013; A61F 2005/0016;
A61F 2005/002; A61F 2005/0023; A61F
2250/0003; A61F 2250/0004; A61F 2250/001;
A61F 2250/0013; A61F 2/004; A61F 2/0046;
A61F 2/0053; A61F 2/0056; A61F 2/0069;
A61F 2/0003; A61F 2/0013; A61F 2/0033;
A61F 2/0036; A61M 25/10185; A61M
25/1018; A61M 2025/1059
USPC 424/422-423; 600/37; 604/26, 96.01,
604/104; 606/153, 157, 191-192, 198
See application file for complete search history.

(56) **References Cited**

U.S. PATENT DOCUMENTS

4,694,827 A 9/1987 Weiner et al.
4,803,985 A 2/1989 Hill

(Continued)

FOREIGN PATENT DOCUMENTS

EP 1 004 330 5/2000
EP 1 736 123 12/2006

(Continued)

OTHER PUBLICATIONS

International Search Report for PCT/SE2009/000049, mailed Jun. 11, 2009.

(Continued)

Primary Examiner — Jonathan W Miles

Assistant Examiner — Kendra Obu

(57) **ABSTRACT**

The invention relates surgical abdominal methods of treating obesity in a patient by implanting a volume filling device that, when implanted in a patient, reduces the food cavity in size by a volume substantially exceeding the volume of the volume filling device. Also disclosed is a laparoscopic instrument for providing a volume filling device to be invaginated in the stomach wall of a human patient to treat obesity.

18 Claims, 41 Drawing Sheets

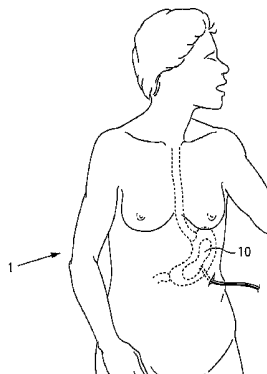

(56)

References Cited

FOREIGN PATENT DOCUMENTS

WO	WO 01/67964	9/2001
WO	WO 02/38217	5/2002
WO	WO 02/082968	10/2002
WO	WO 02/100481	12/2002
WO	WO 2004/019765	3/2004
WO	WO 2004/112563	12/2004
WO	WO 2005/037152	4/2005
WO	WO 2005/105003	11/2005
WO	WO 2006/044640	4/2006
WO	WO 2006/063593	6/2006
WO	WO 2006/122285	11/2006
WO	WO 2006/134106	12/2006
WO	WO 2007/017880	2/2007
WO	WO 2007/053556	5/2007
WO	WO 2007/137026	11/2007
WO	WO 2008/016776	2/2008
WO	WO 2009/076093	6/2009
WO	WO 2009/096865	8/2009

OTHER PUBLICATIONS

Wise Geek, What are Isotonic Fluids? 2003.

U.S. Appl. No. 12/864,708 (Forsell) filed Jul. 27, 2010.

U.S. Appl. No. 12/864,833 (Forsell) filed Jul. 27, 2010.
 U.S. Appl. No. 12/864,836 (Forsell) filed Jul. 27, 2010.
 U.S. Appl. No. 12/864,843 (Forsell) filed Jul. 27, 2010.
 U.S. Appl. No. 12/864,845 (Forsell) filed Jul. 27, 2010.
 U.S. Appl. No. 12/864,849 (Forsell) filed Jul. 27, 2010.
 U.S. Appl. No. 12/864,852 (Forsell) filed Jul. 27, 2010.
 U.S. Appl. No. 12/864,855 (Forsell) filed Jul. 27, 2010.
 U.S. Appl. No. 12/864,943 (Forsell) filed Jul. 28, 2010.
 U.S. Appl. No. 12/864,947 (Forsell) filed Jul. 28, 2010.
 U.S. Appl. No. 12/864,952 (Forsell) filed Jul. 28, 2010.
 U.S. Appl. No. 12/864,982 (Forsell) filed Jul. 28, 2010.
 U.S. Appl. No. 12/865,015 (Forsell) filed Jul. 28, 2010.
 U.S. Appl. No. 12/865,033 (Forsell) filed Jul. 28, 2010.
 U.S. Appl. No. 12/865,044 (Forsell) filed Jul. 28, 2010.
 U.S. Appl. No. 12/865,061 (Forsell) filed Jul. 28, 2010.
 U.S. Appl. No. 12/865,071 (Forsell) filed Jul. 28, 2010.
 U.S. Appl. No. 13/123,014 (Forsell) filed Apr. 7, 2011.
 U.S. Appl. No. 13/123,019 (Forsell) filed Apr. 7, 2011.
 U.S. Appl. No. 13/123,025 (Forsell) filed Apr. 7, 2011.
 U.S. Appl. No. 13/123,261 (Forsell) filed Apr. 8, 2011.
 U.S. Appl. No. 13/146,314 (Forsell) filed Oct. 11, 2011.
 U.S. Appl. No. 13/146,387 (Forsell) filed Oct. 11, 2011.
 U.S. Appl. No. 13/146,454 (Forsell) filed Oct. 11, 2011.
 U.S. Appl. No. 13/146,753 (Forsell) filed Oct. 11, 2011.

* cited by examiner

Fig.1

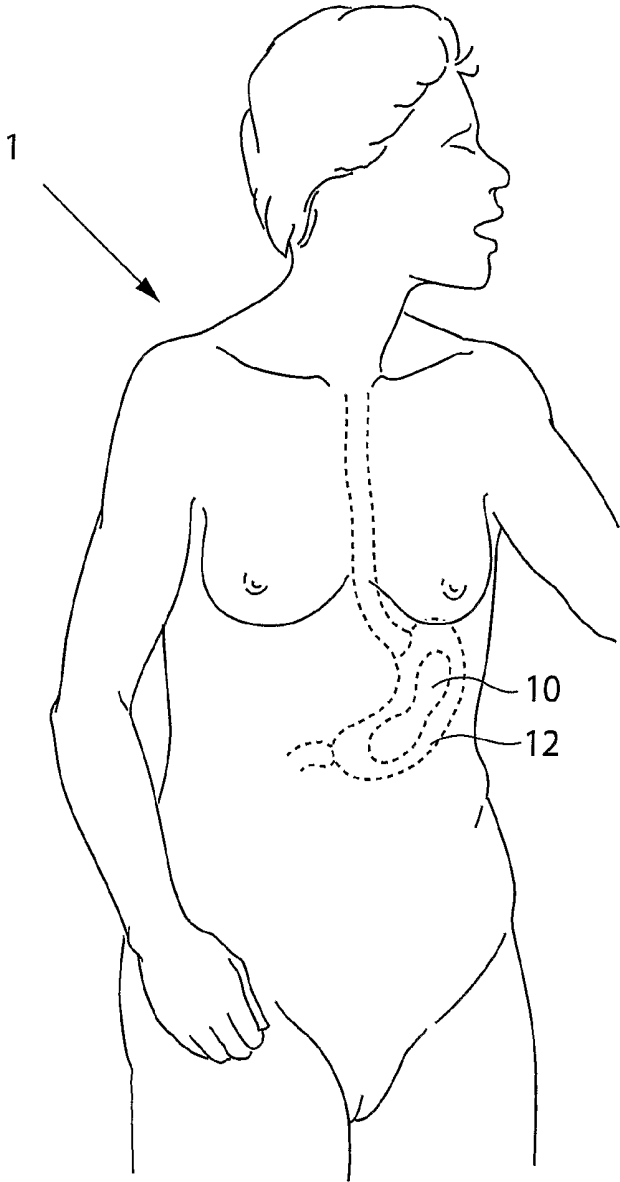

Fig.2a

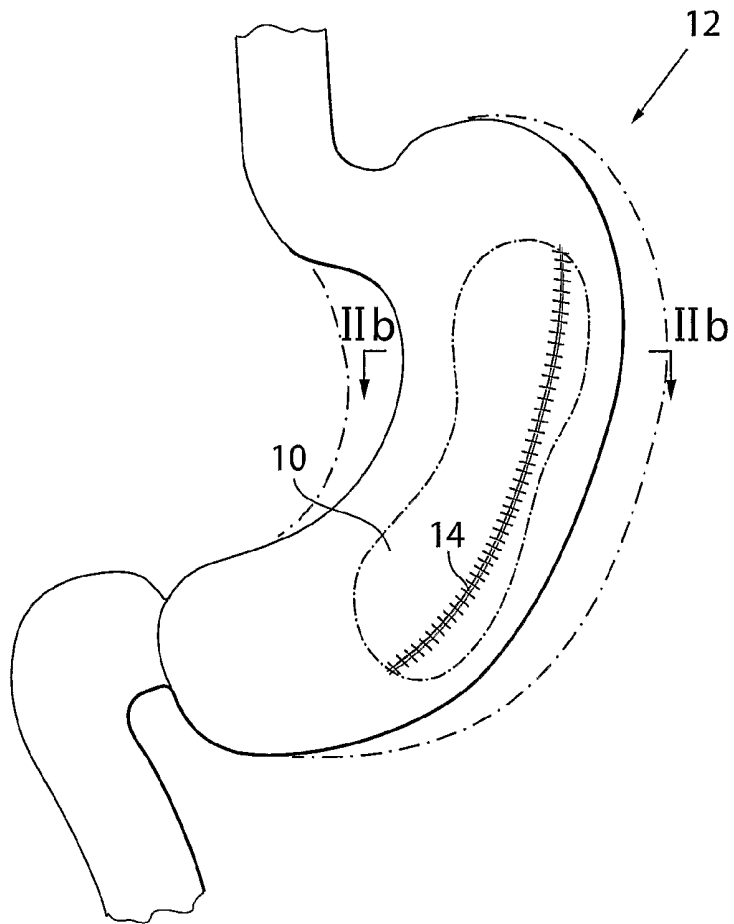
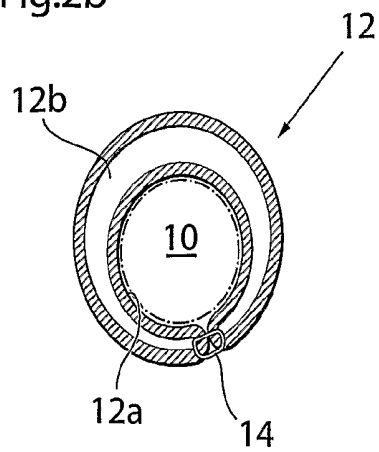

Fig.2b



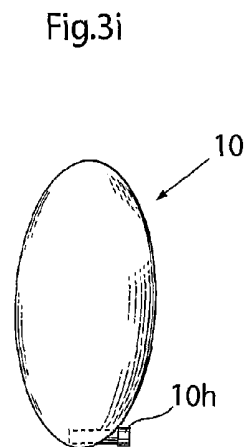
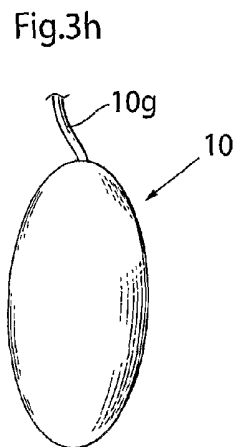
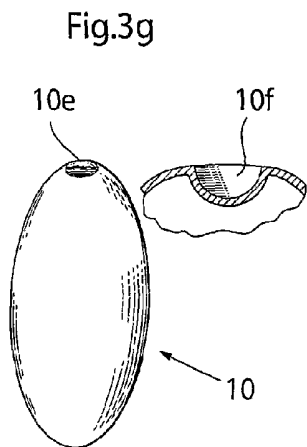
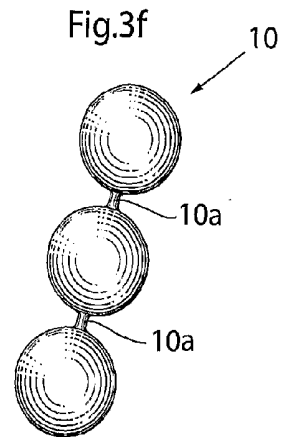
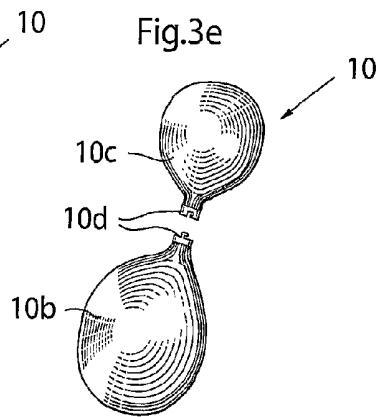
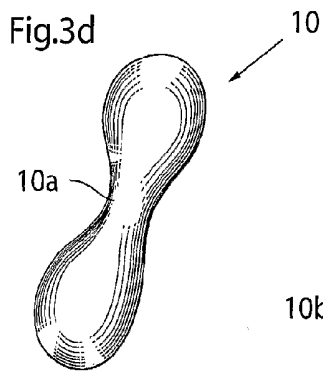
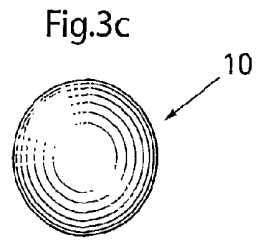
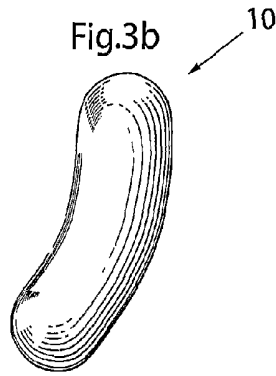
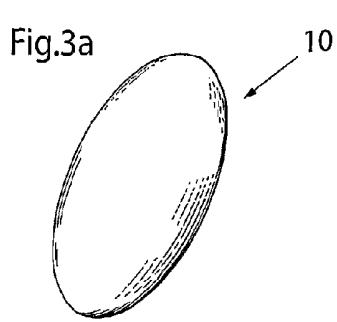

Fig.3j

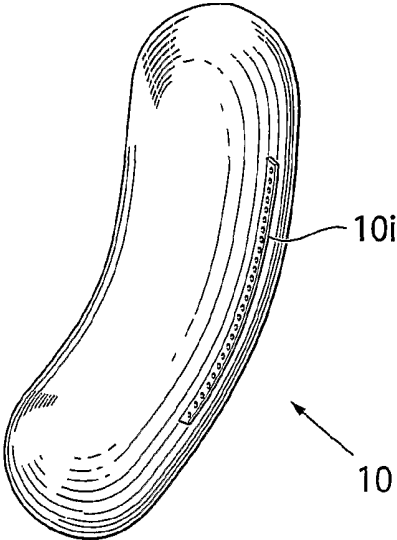

Fig.3k

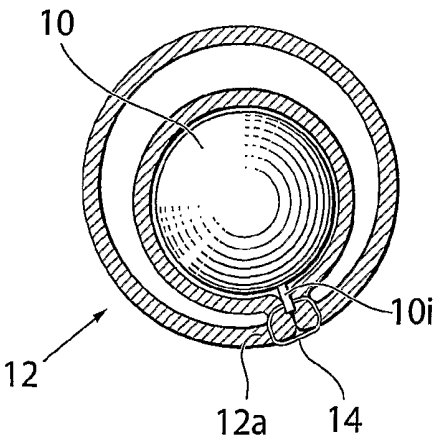

Fig.3m

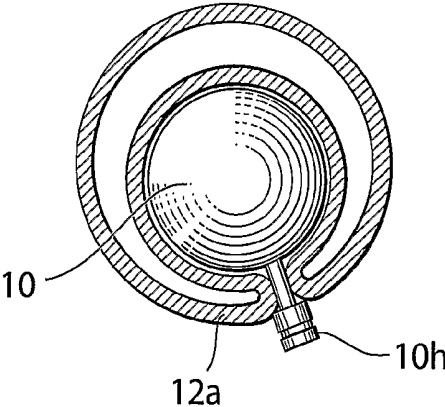

Fig.3n

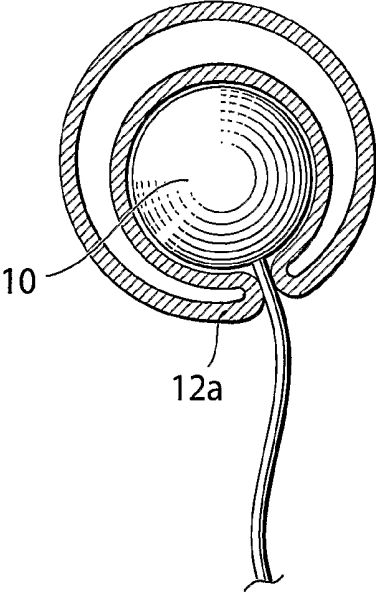

Fig.3p

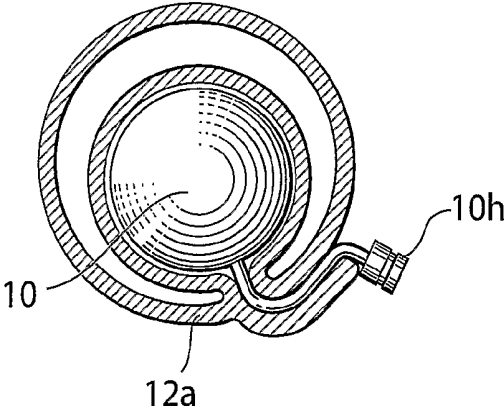

Fig.4a

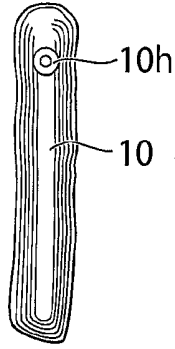

Fig.4b

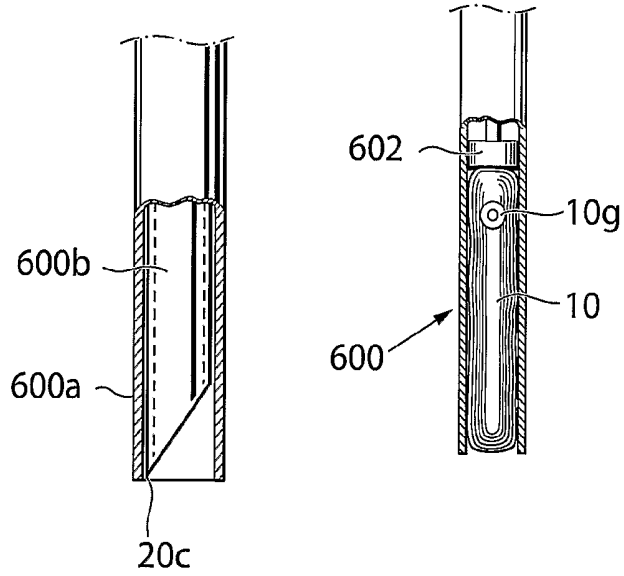

Fig.4c

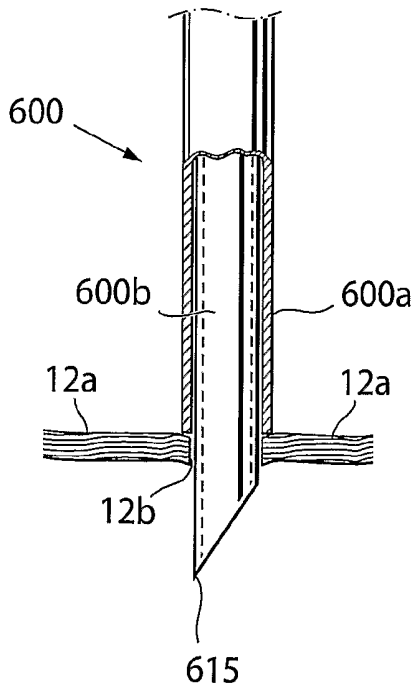

Fig.4d

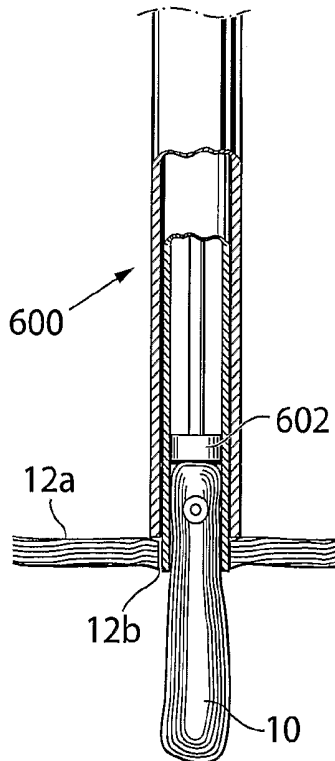

Fig.5a

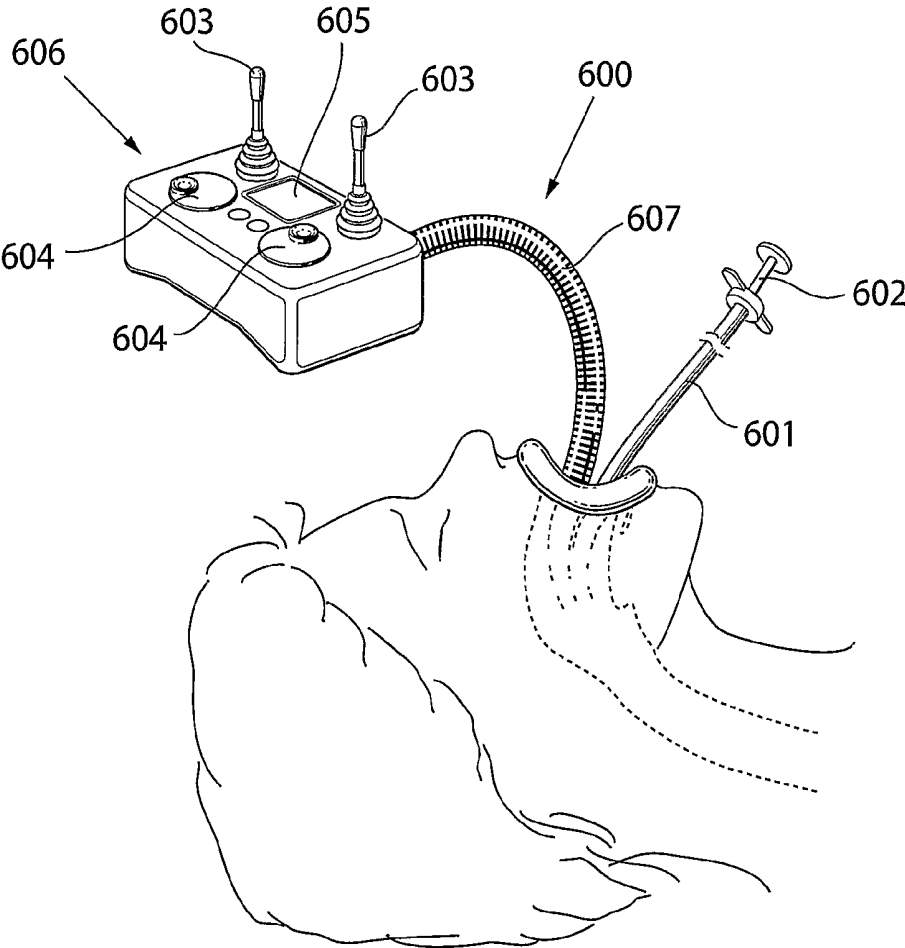

Fig.5b

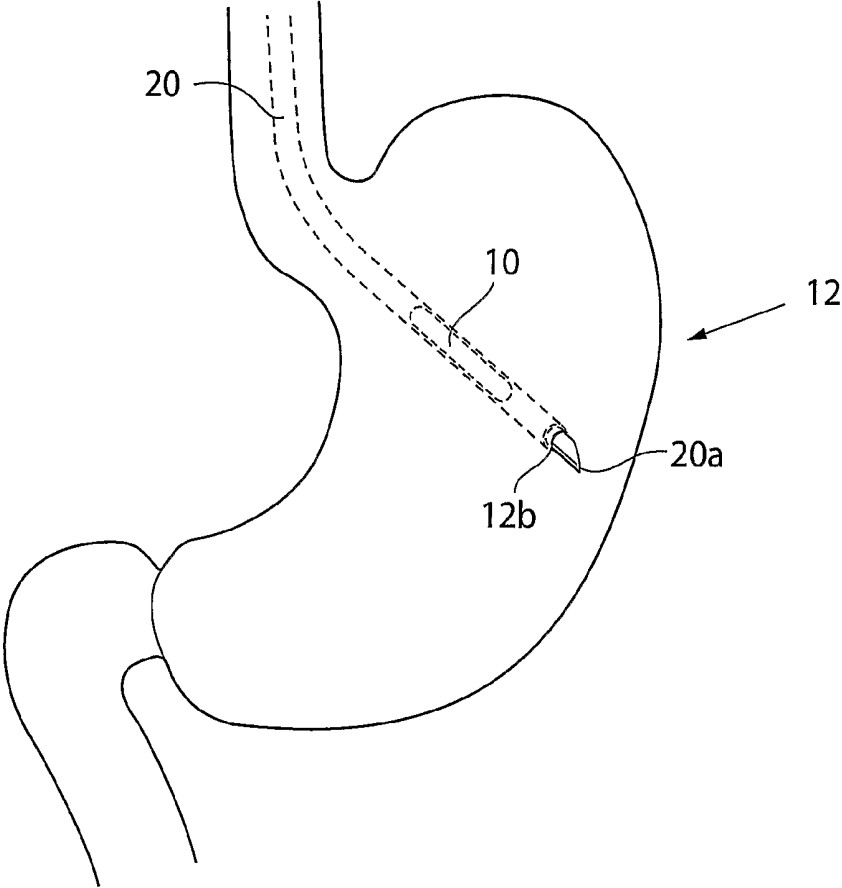

Fig.5c

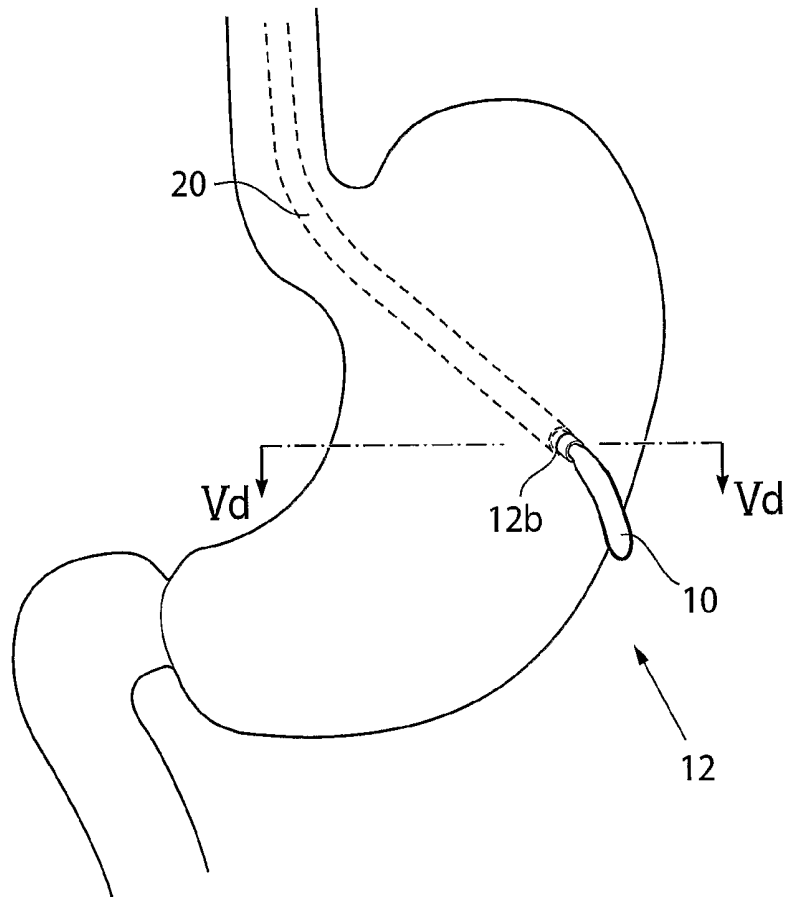

Fig.5d

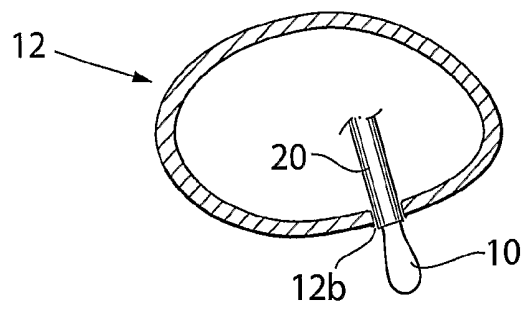

Fig.5e

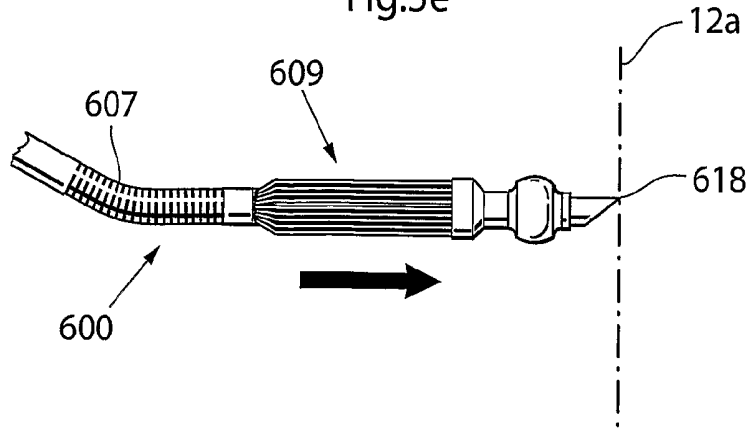

Fig.5f

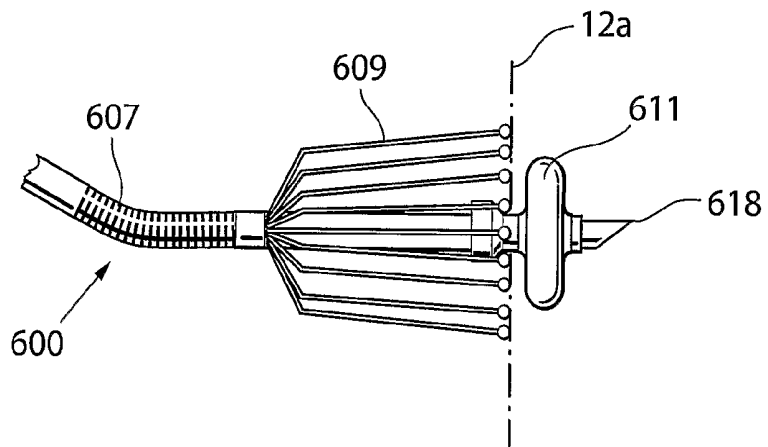

Fig.5g

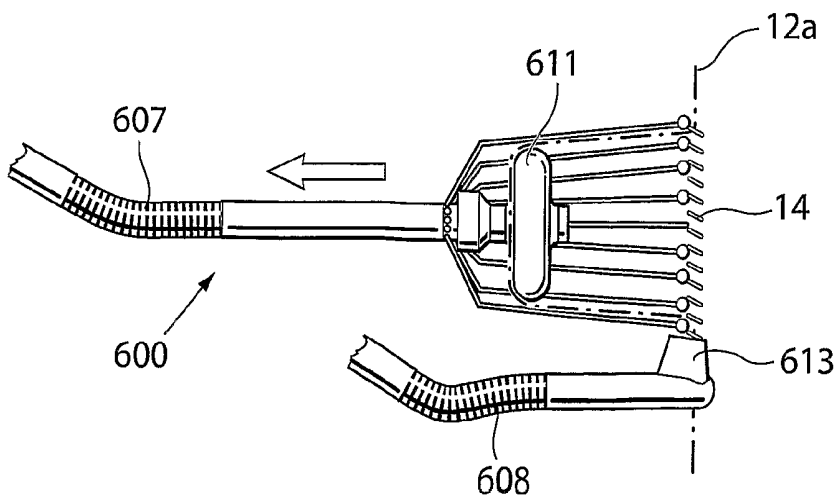

Fig.5h

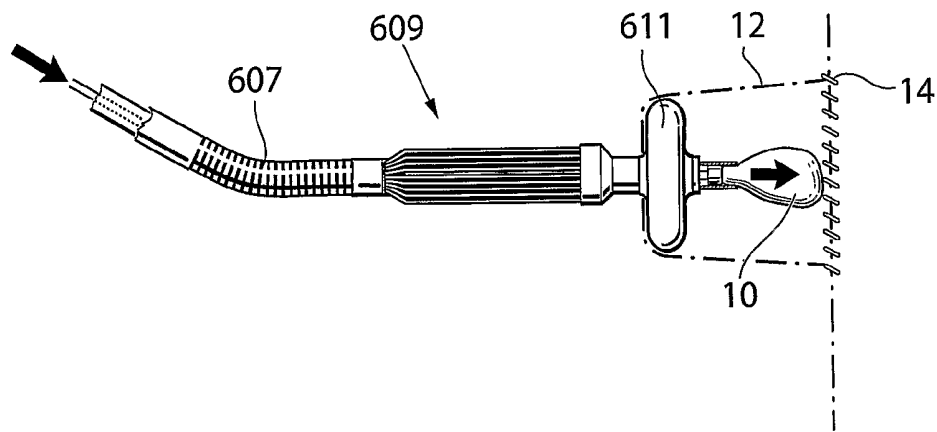

Fig.5i

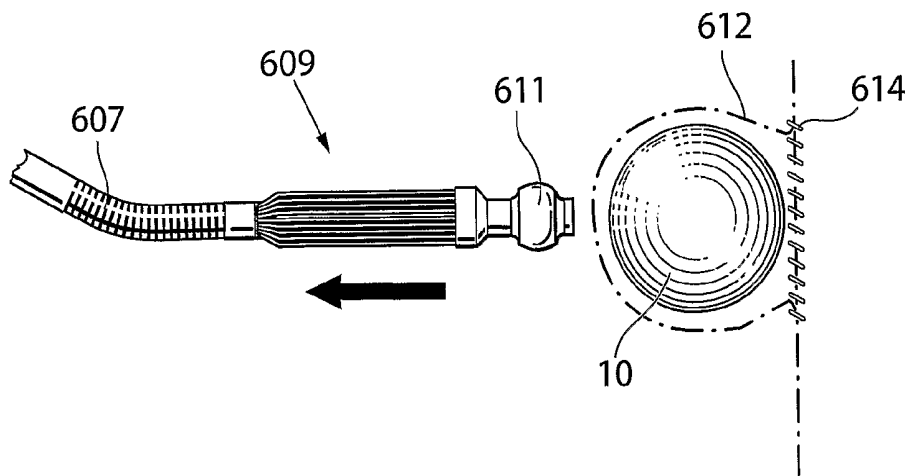

Fig.6a

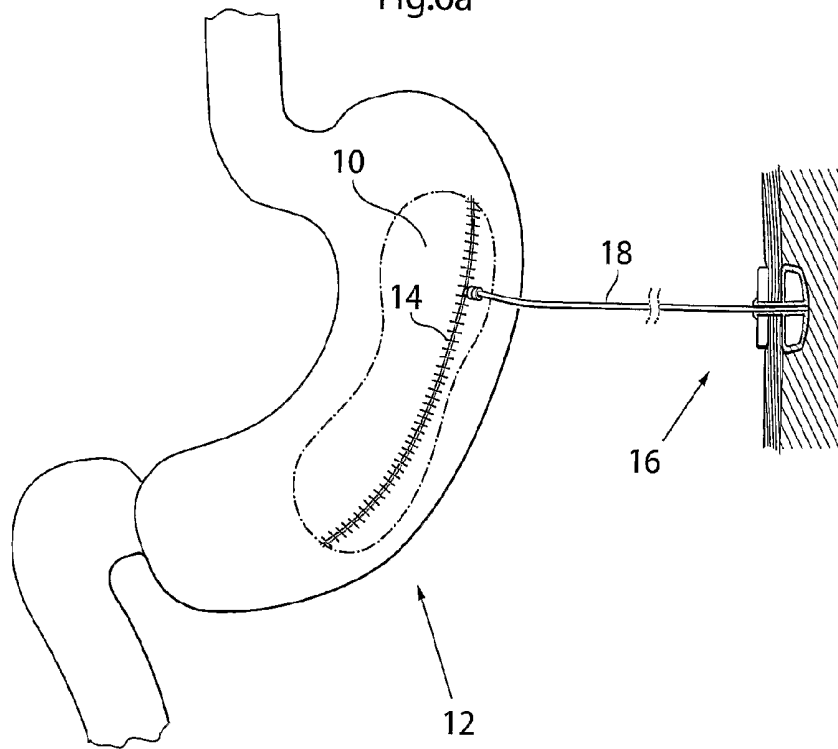

Fig.6b

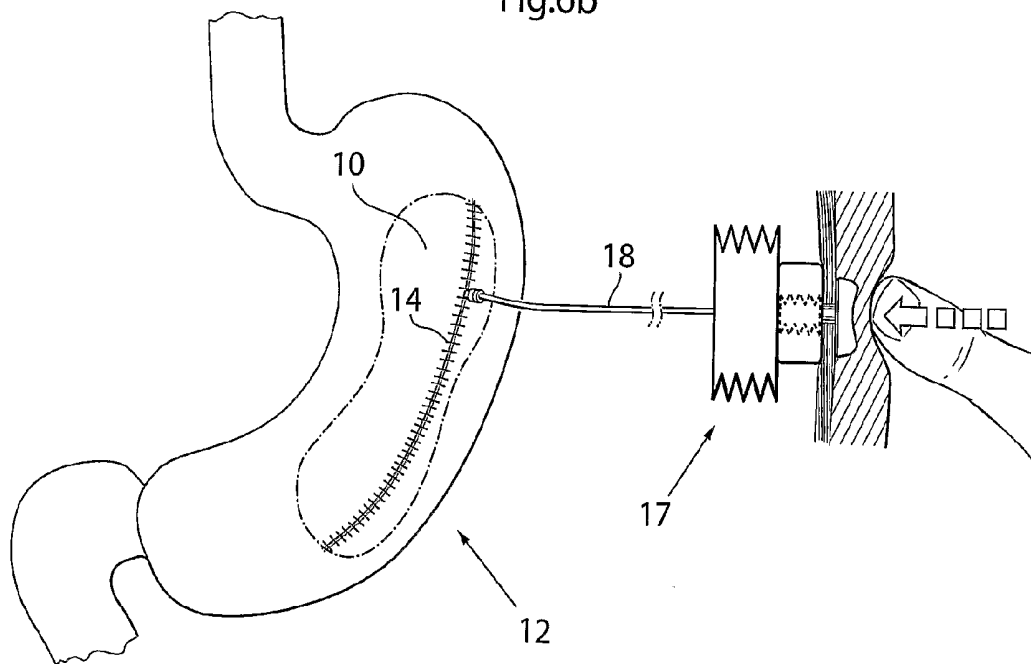

Fig.7

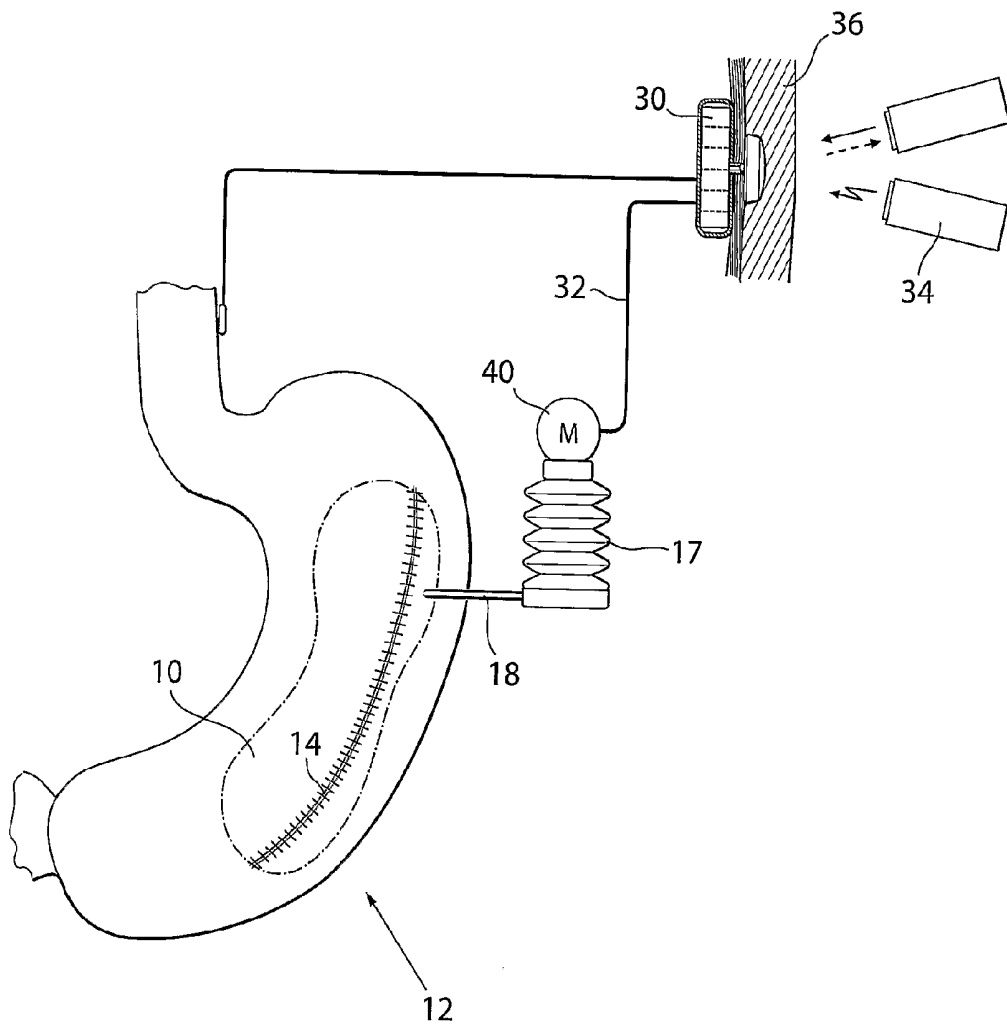
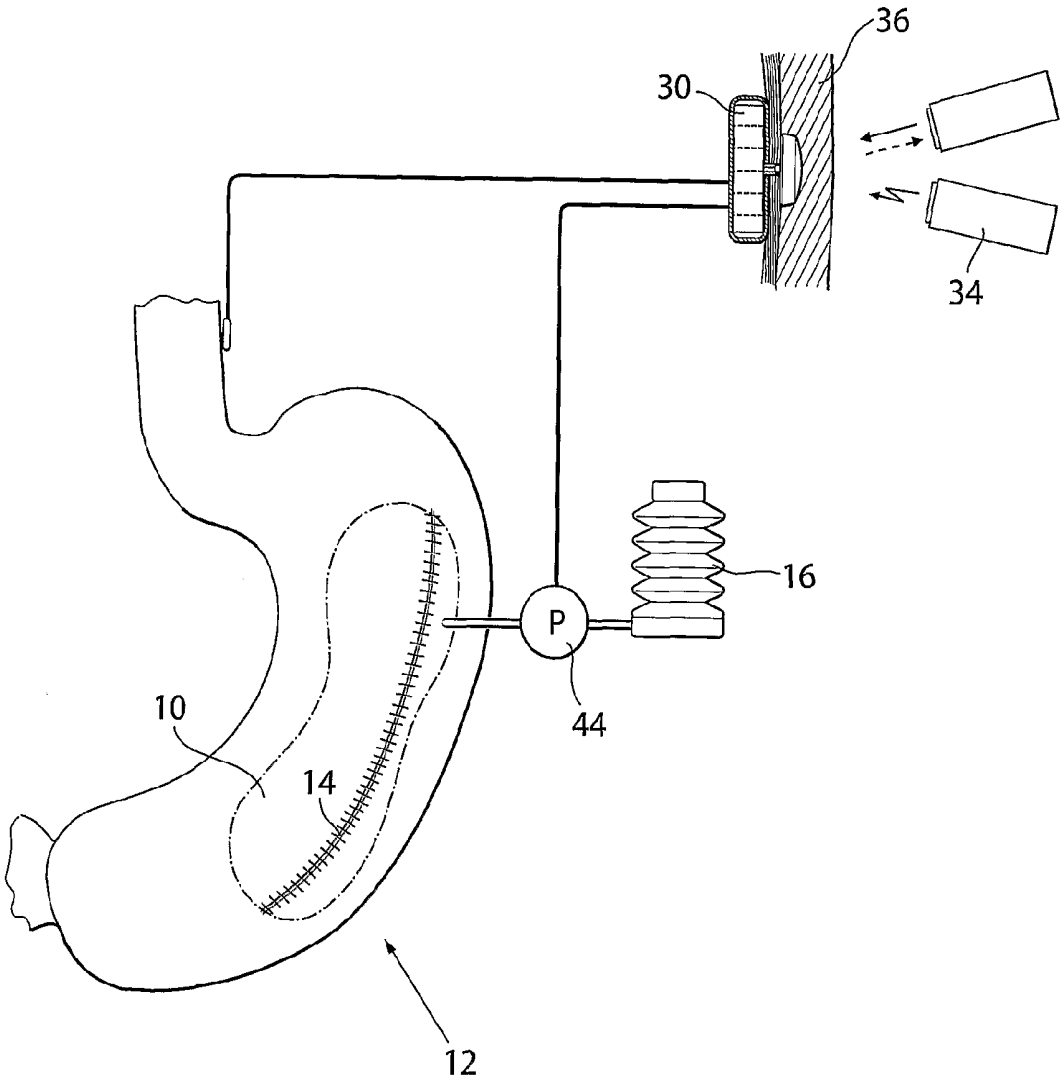

Fig.8



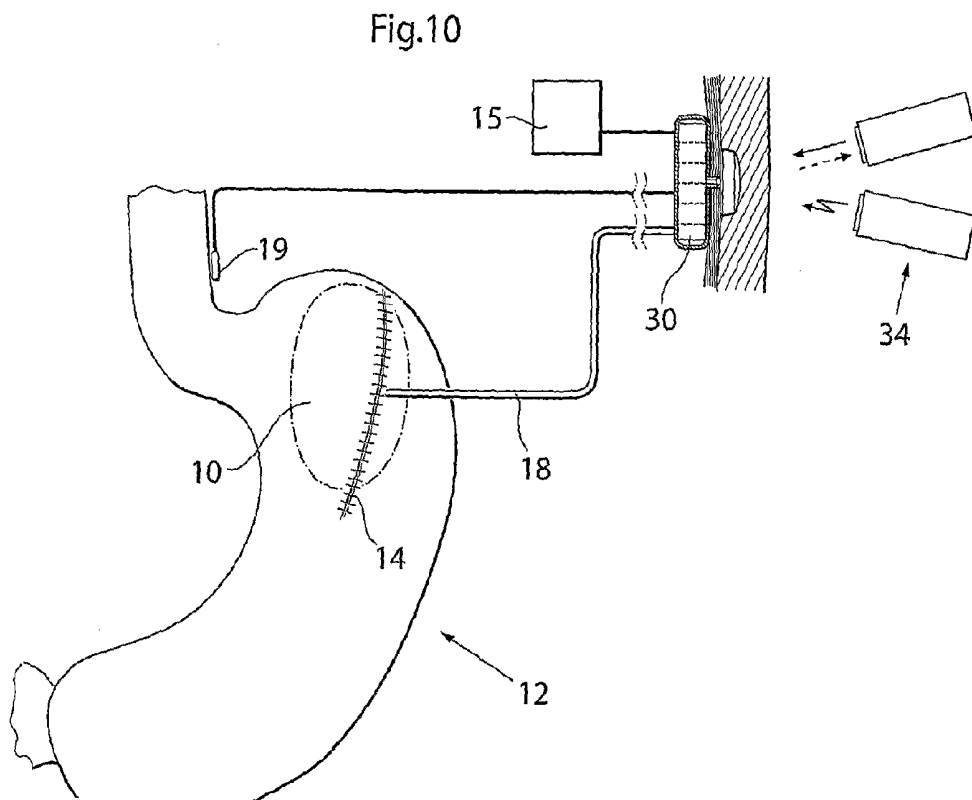
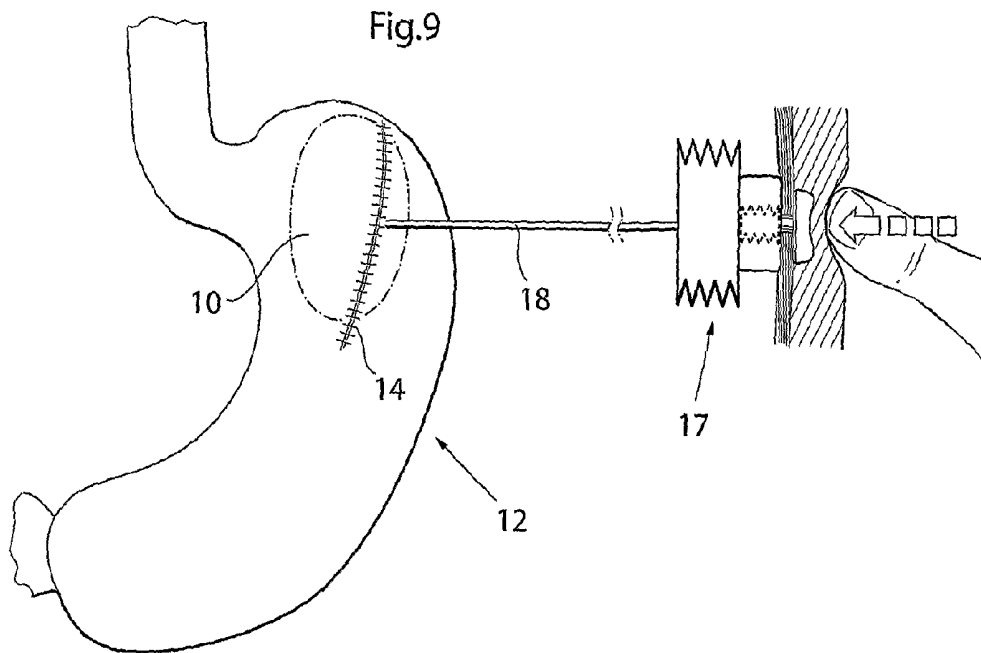

Fig.11

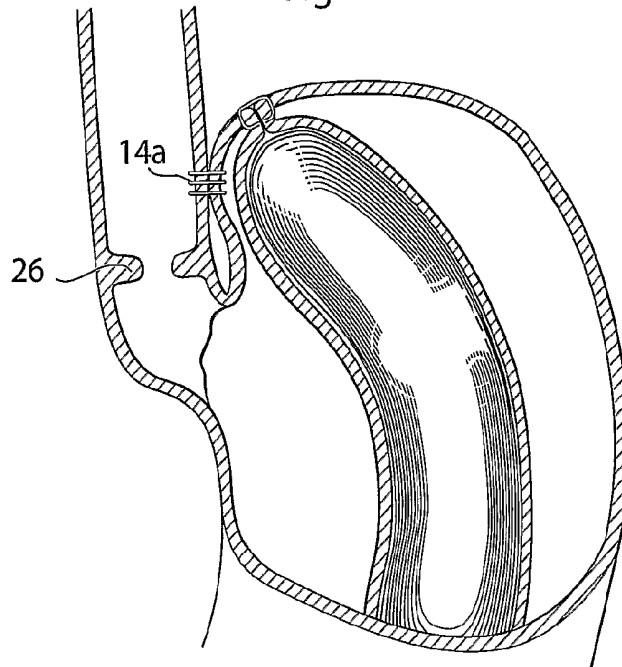

Fig.12

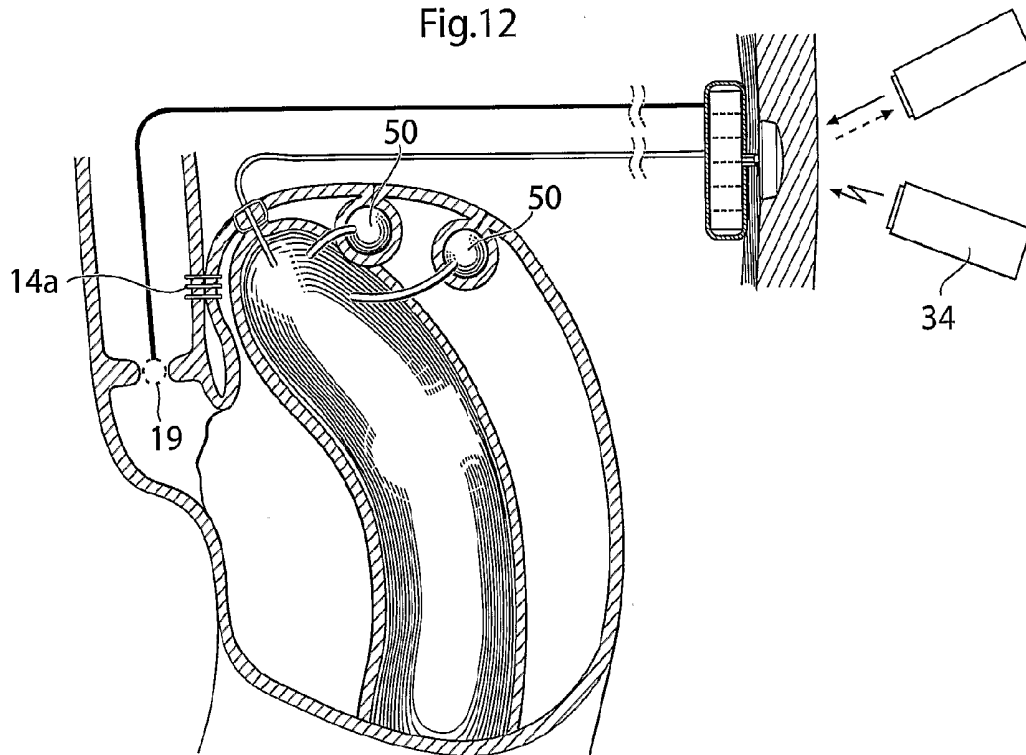

Fig.13

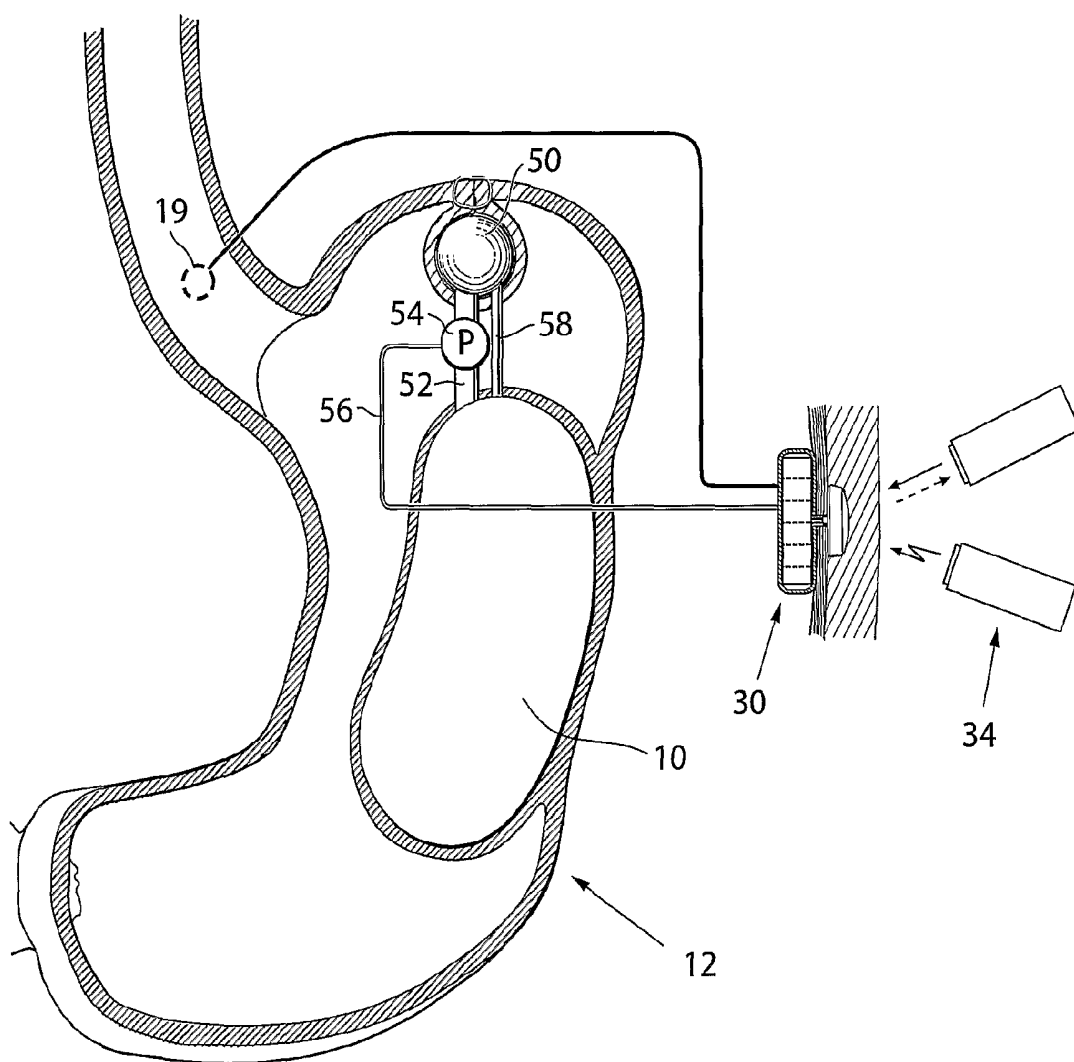

Fig.14

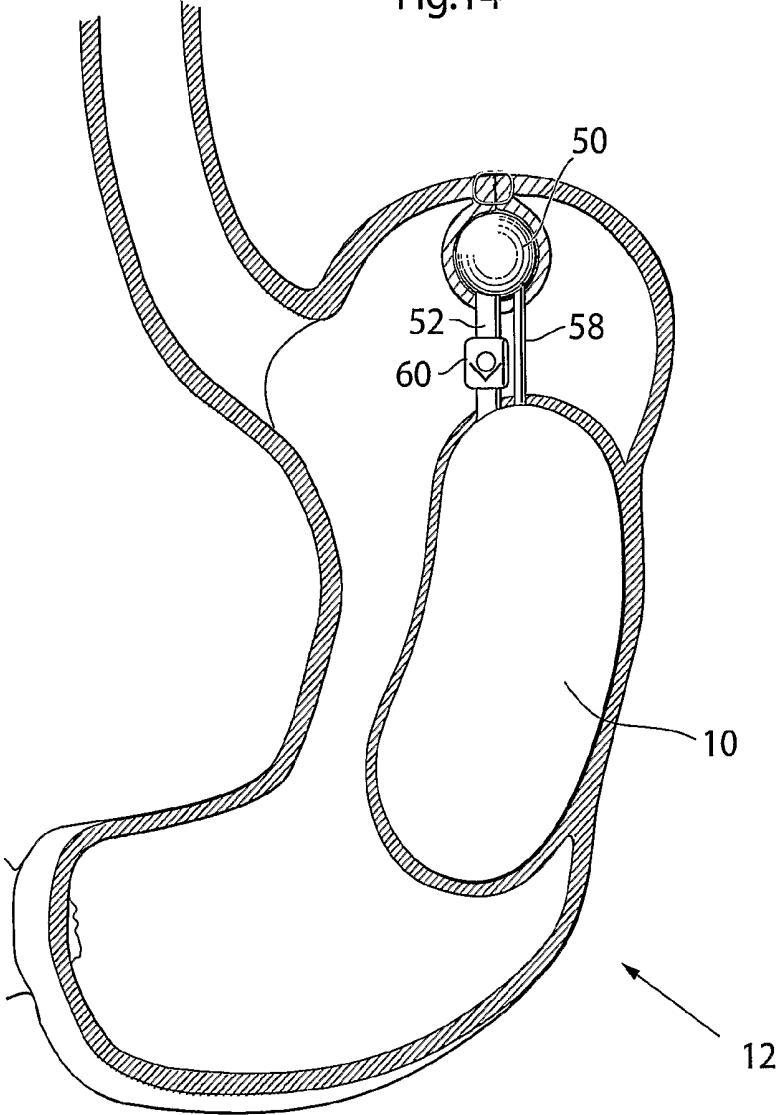

Fig.15

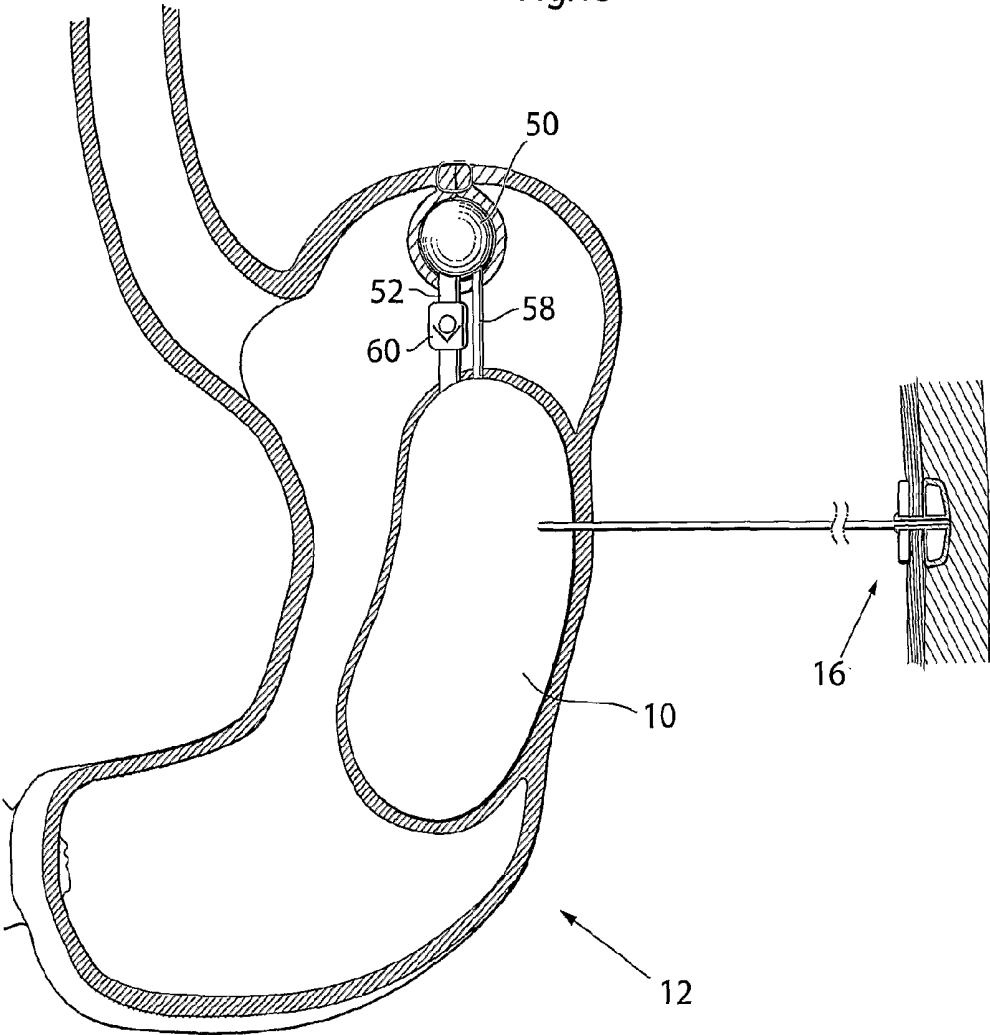
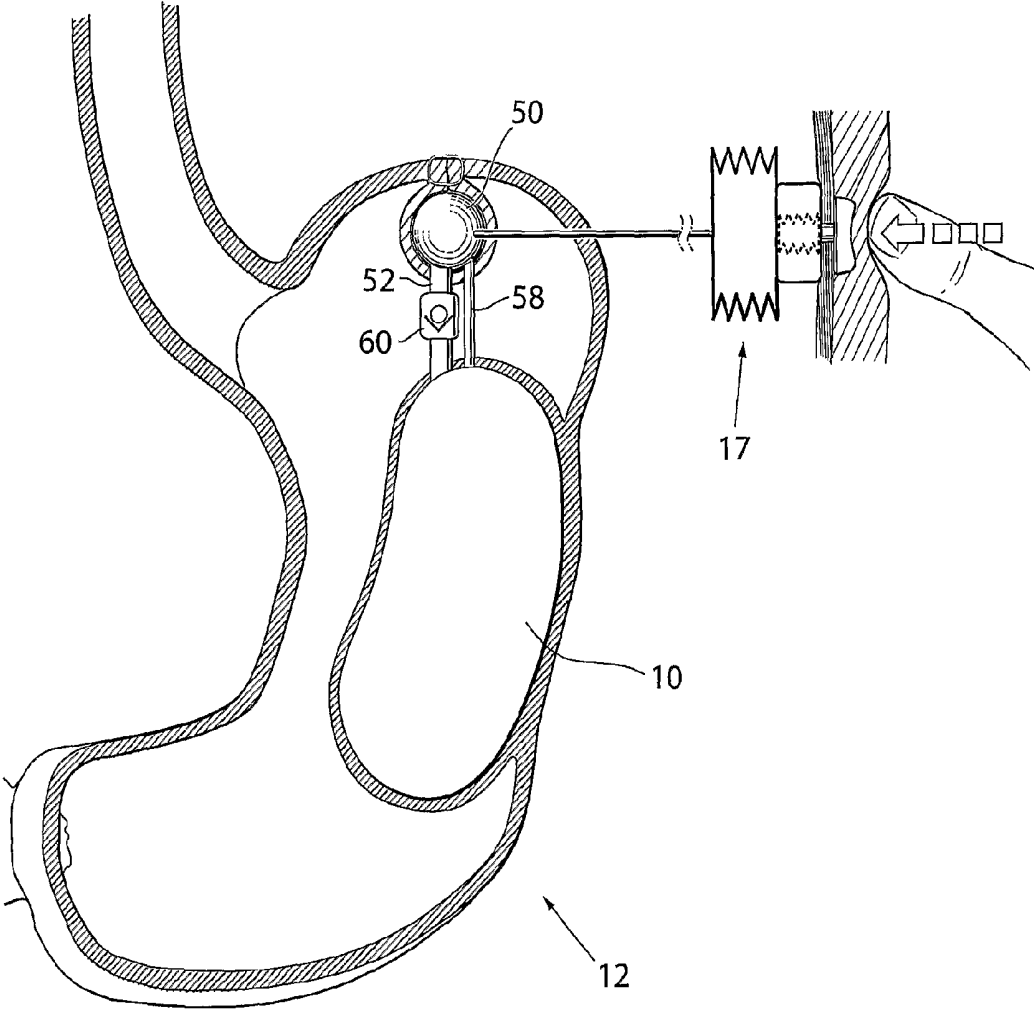
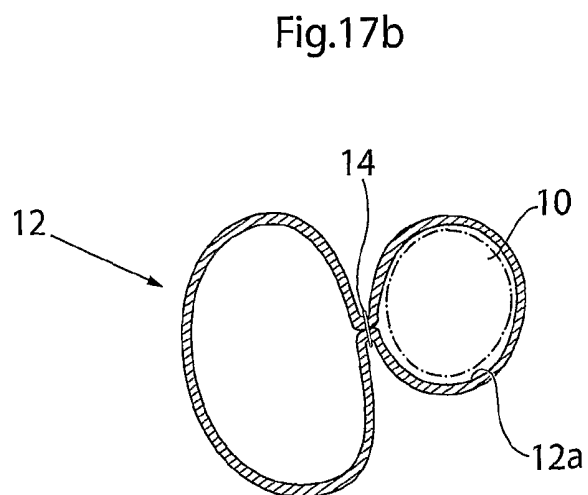
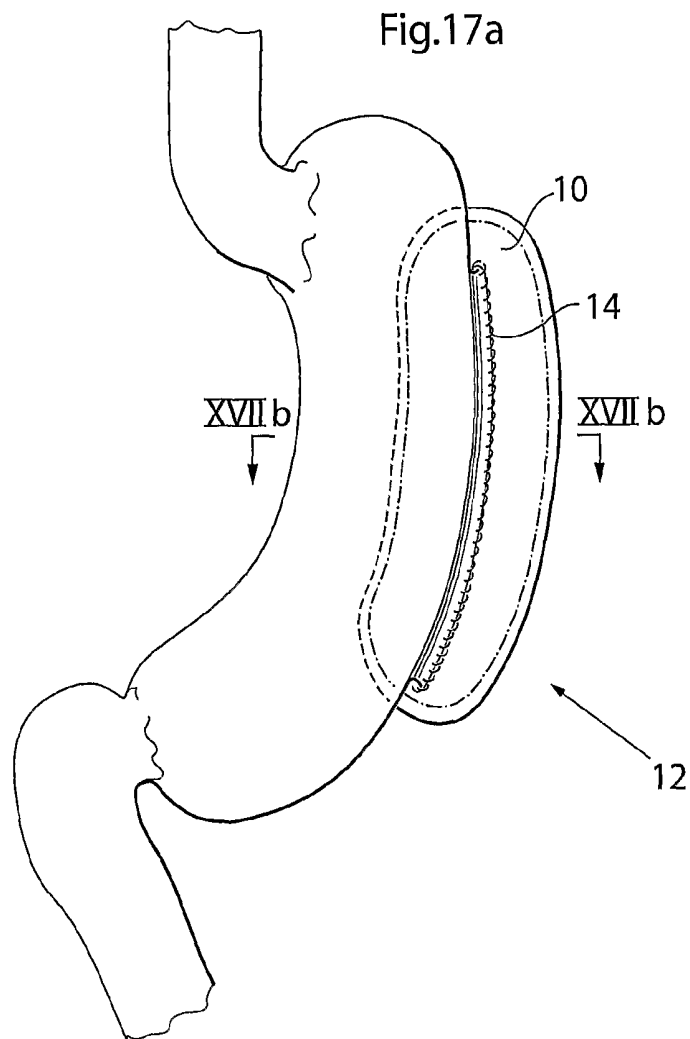

Fig.16





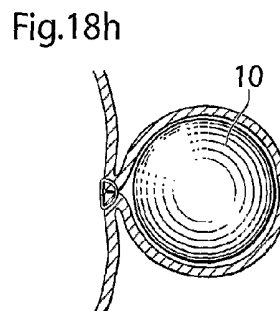
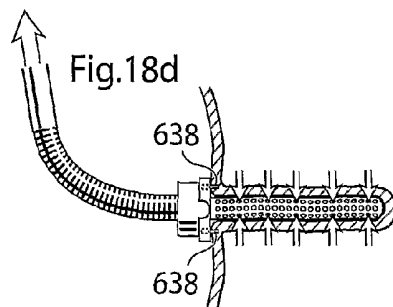
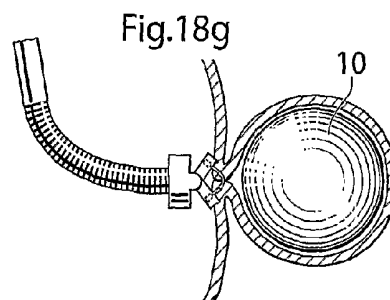
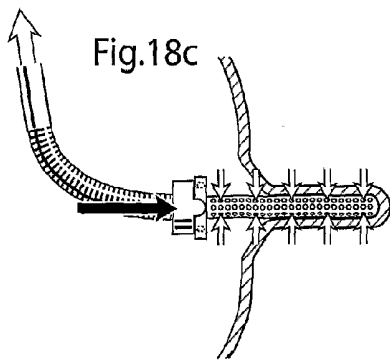
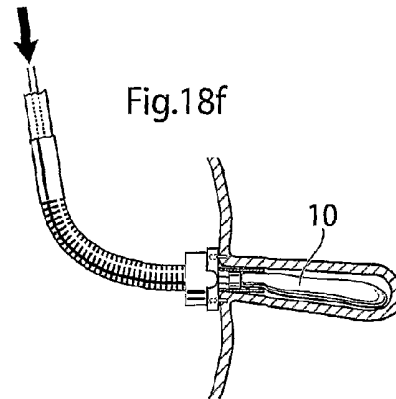
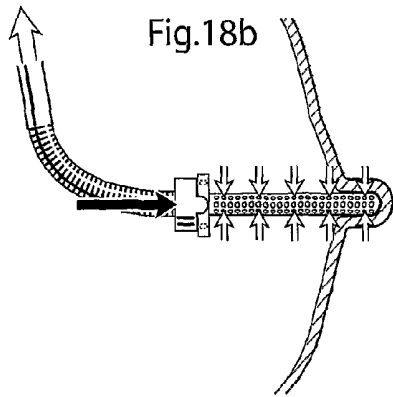
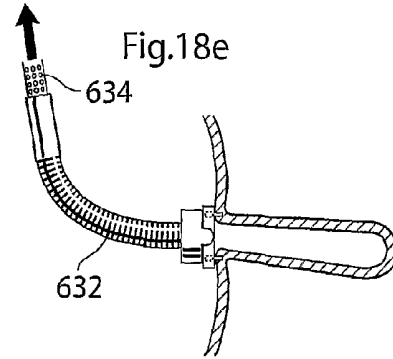
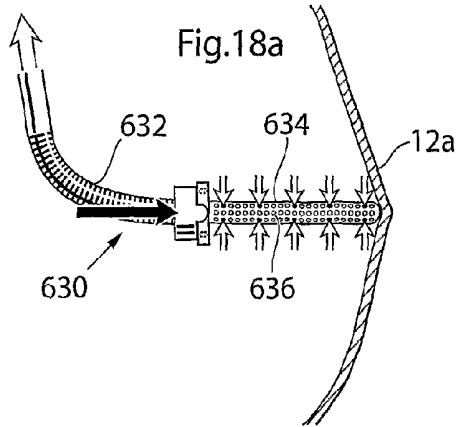

Fig. 19a

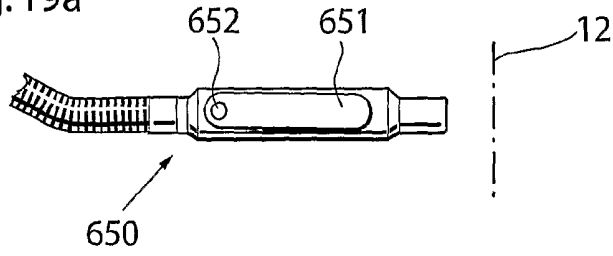

Fig. 19b

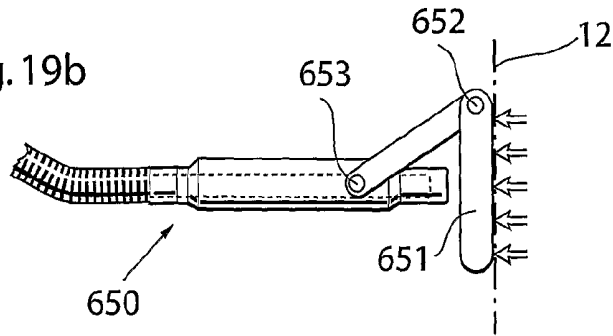

Fig. 19c

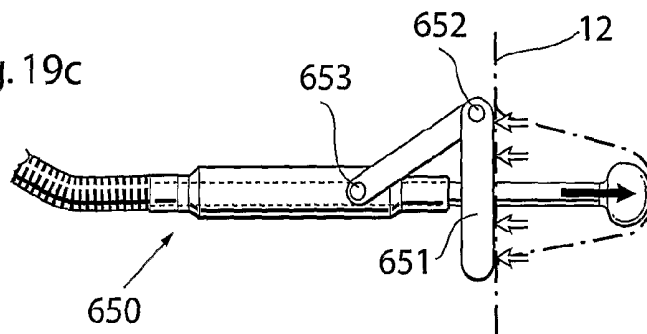

Fig. 19d

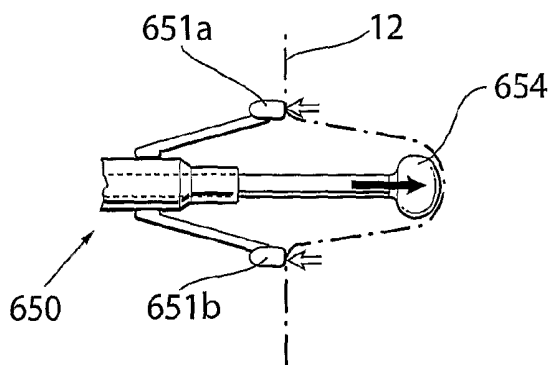
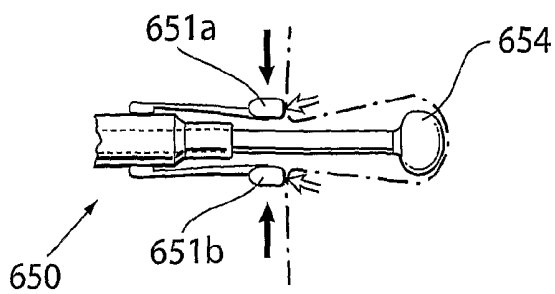
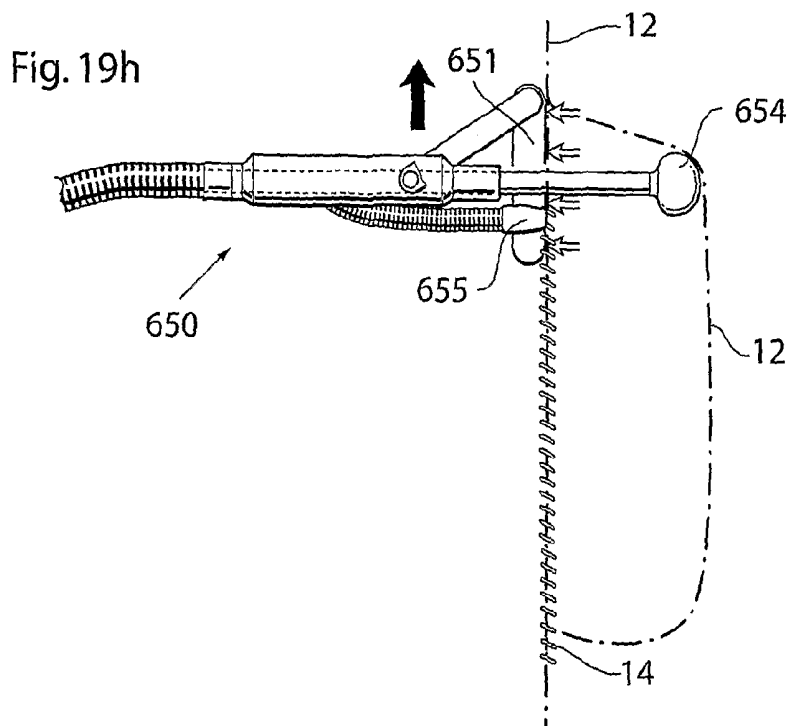
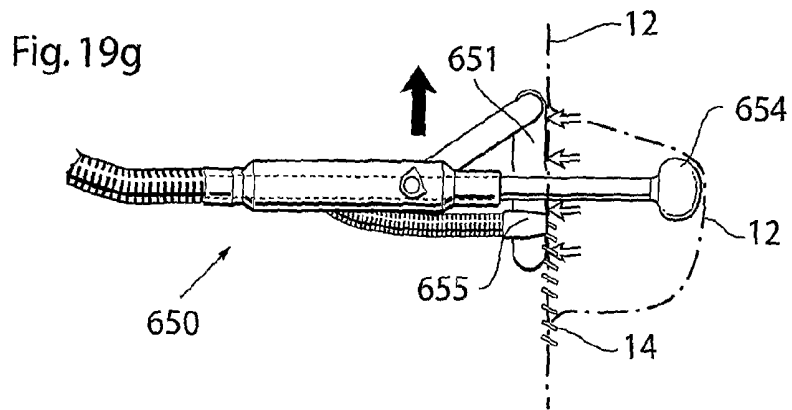
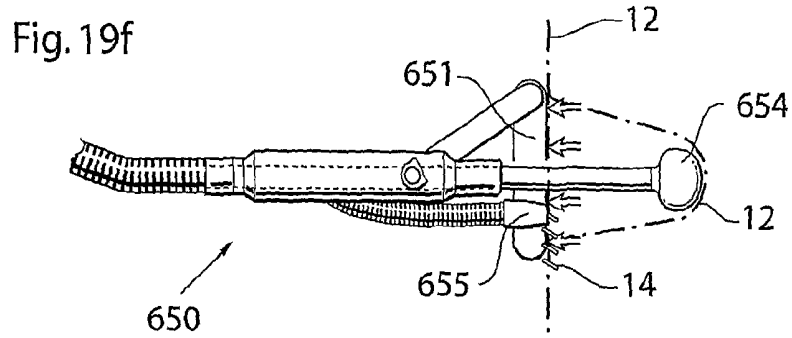

Fig. 19e





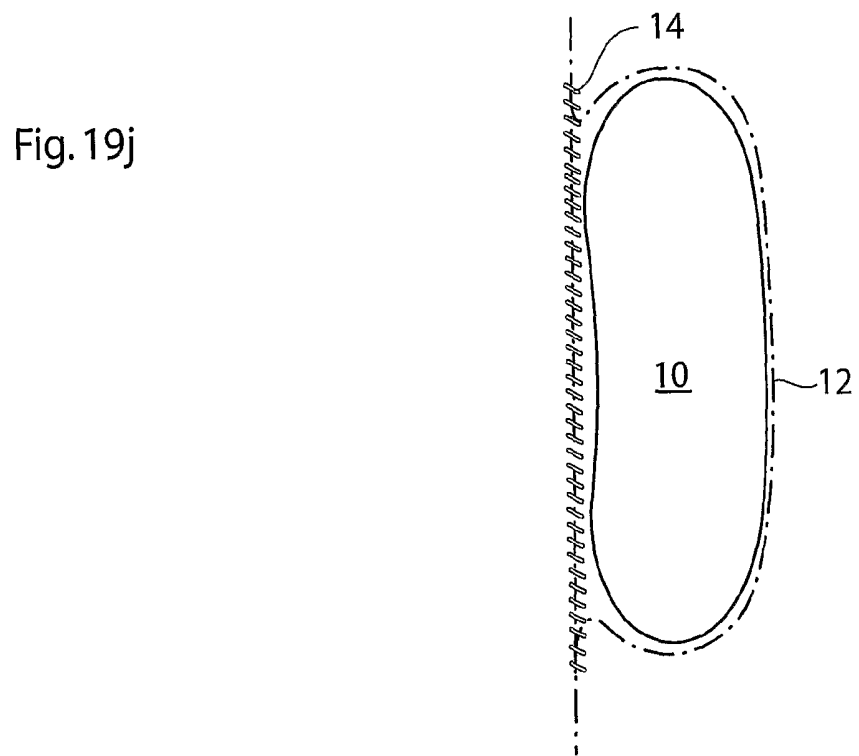
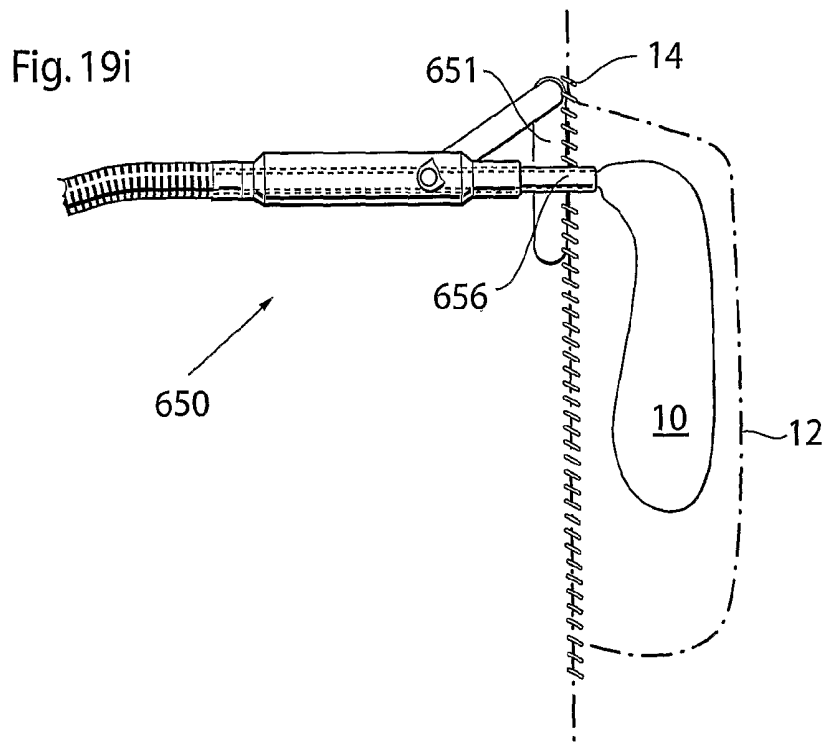

Fig. 20a

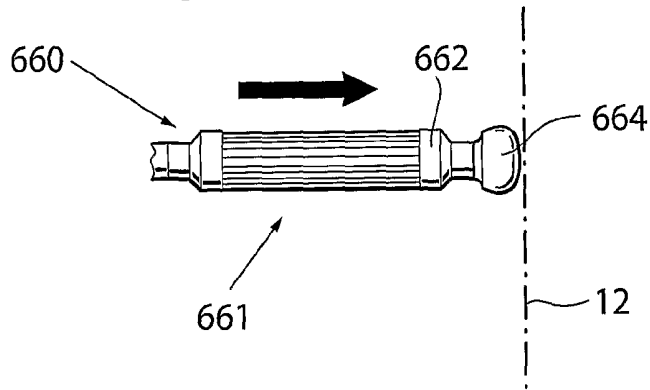

Fig. 20b

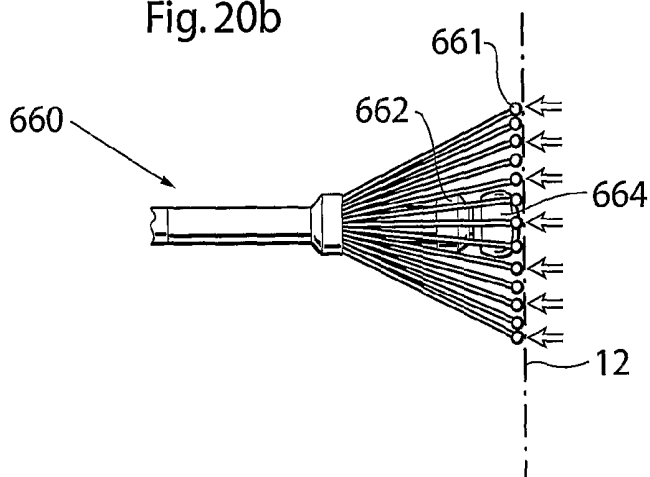

Fig. 20c

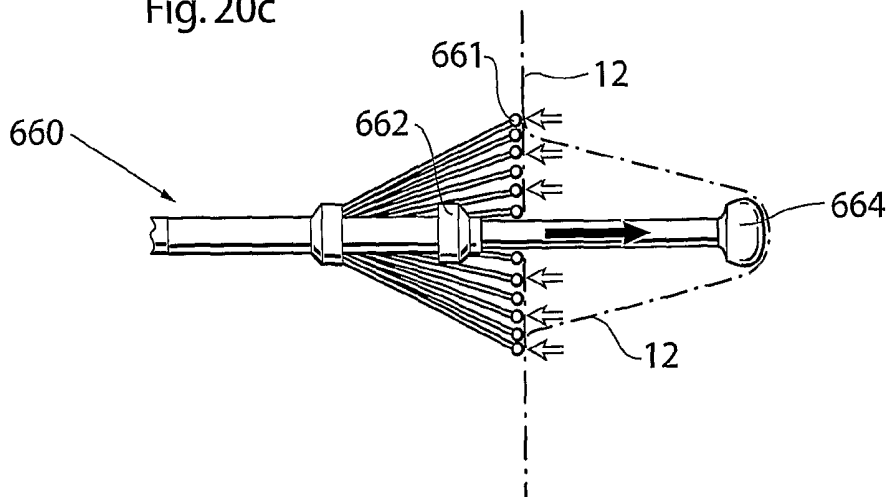

Fig. 20d

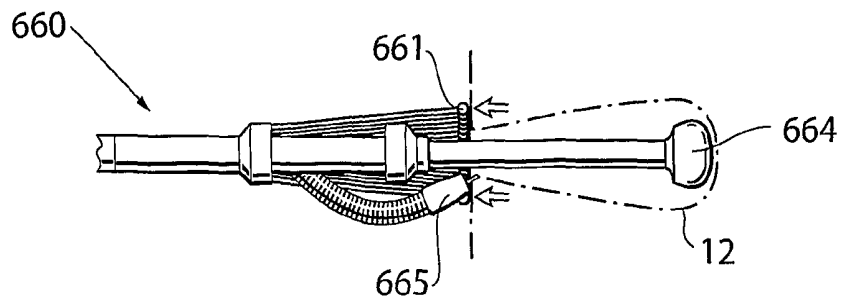

Fig. 20e

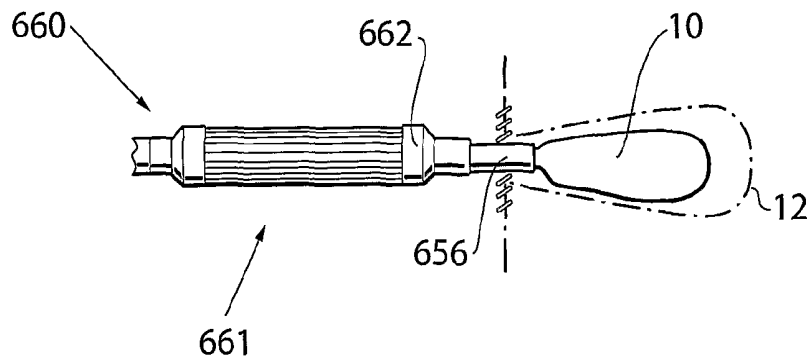

Fig. 20f

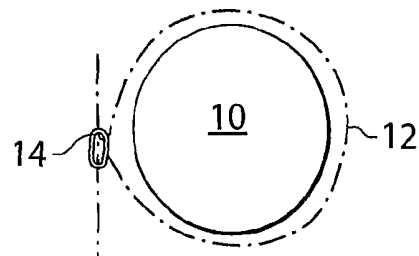

Fig.21a

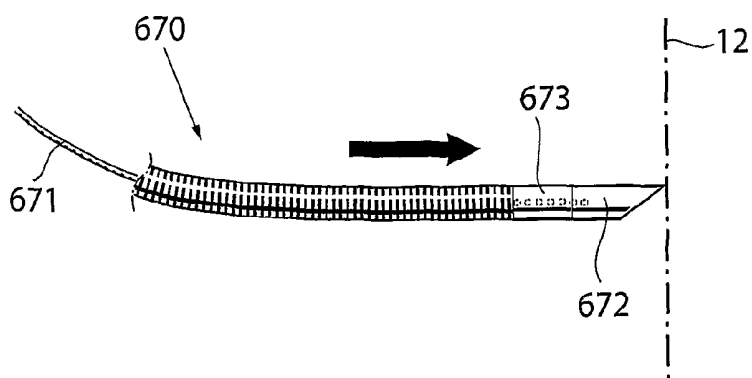

Fig.21b

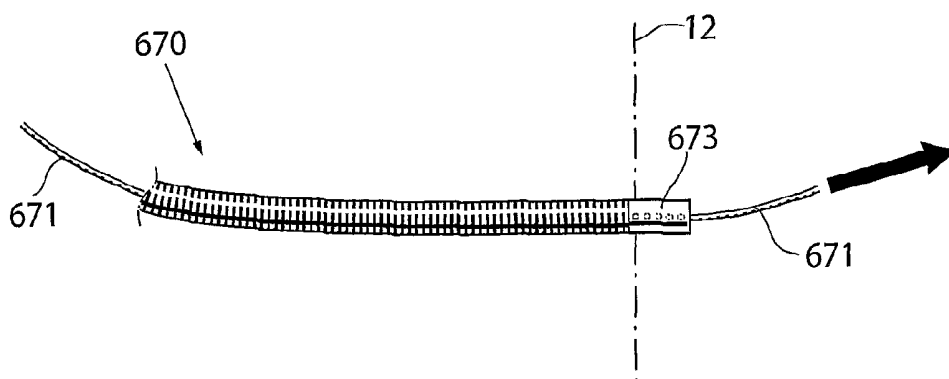
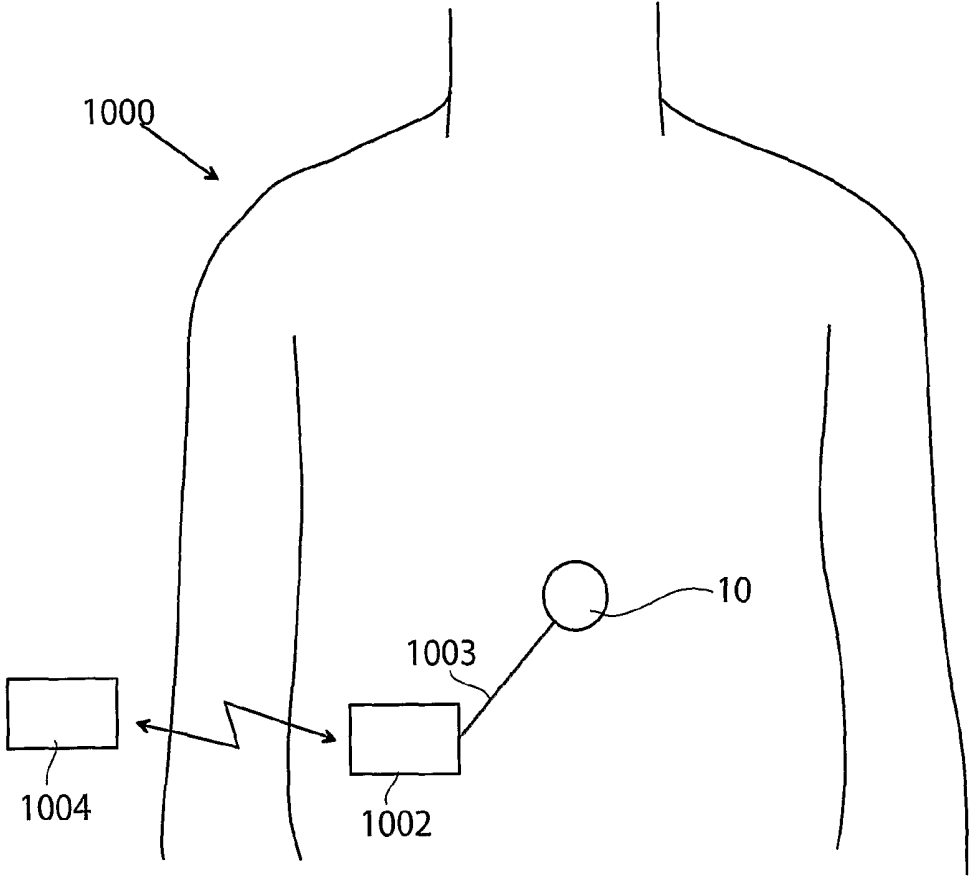

Fig. 22



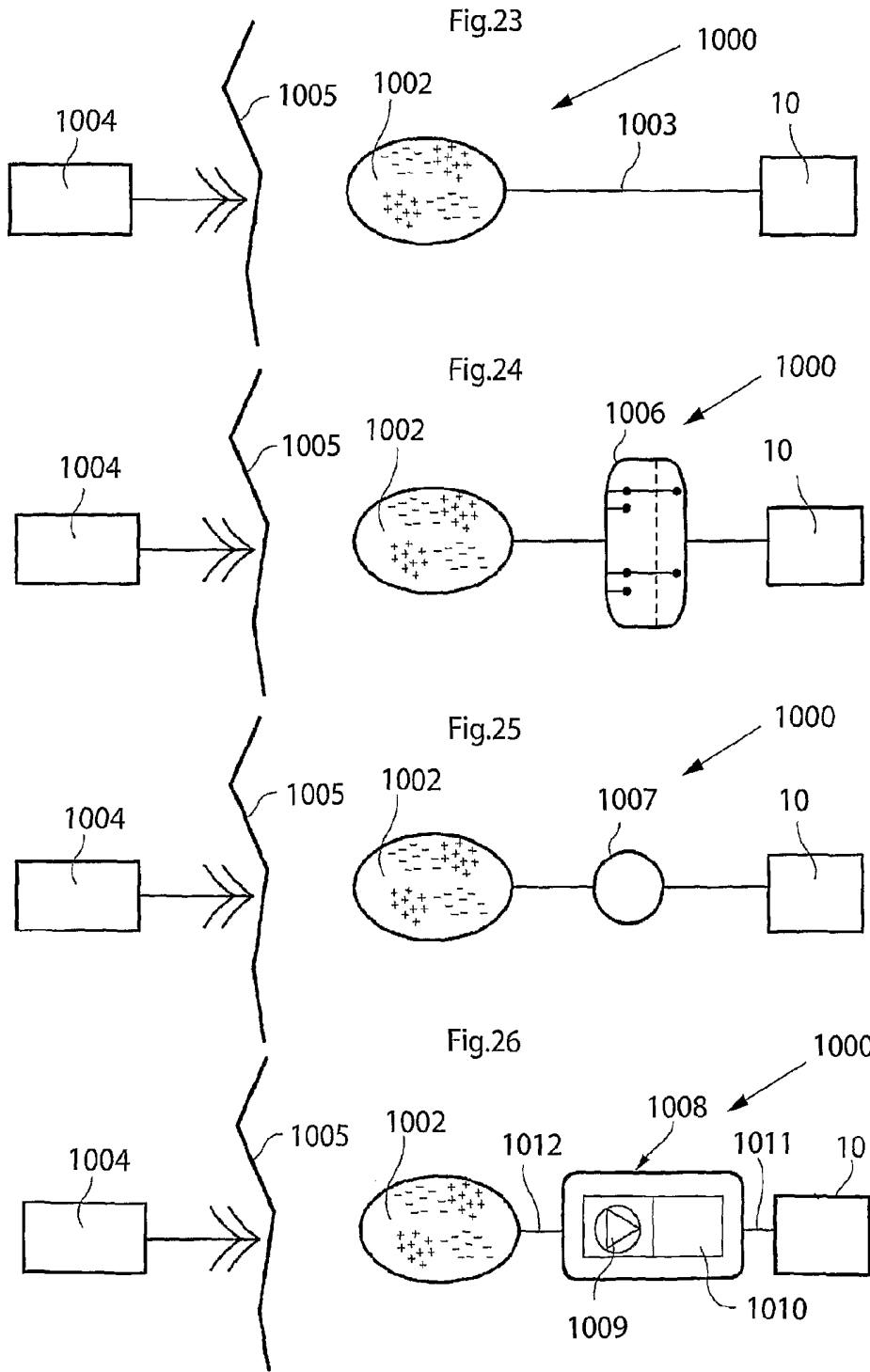

Fig.27

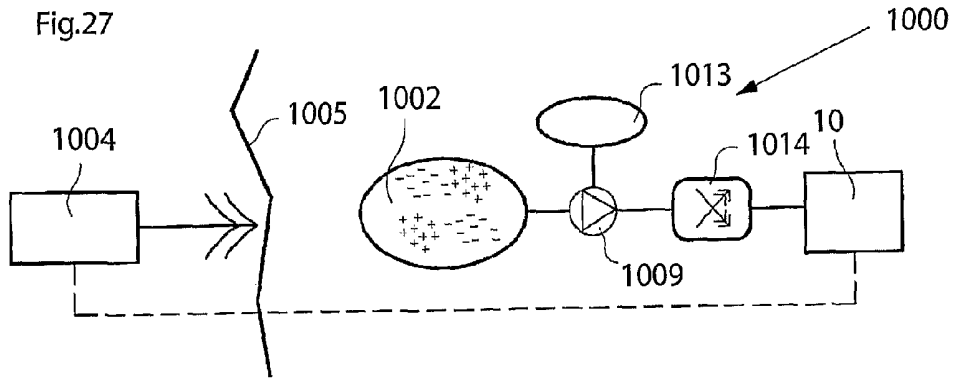

Fig.28

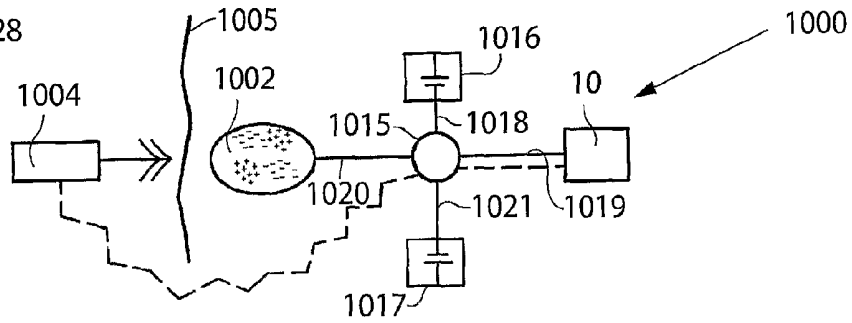

Fig.29

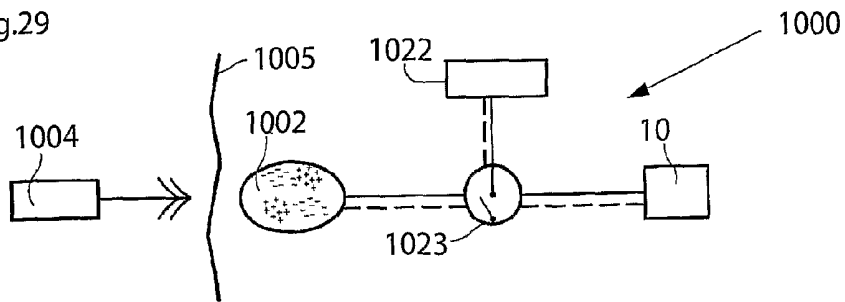

Fig.30

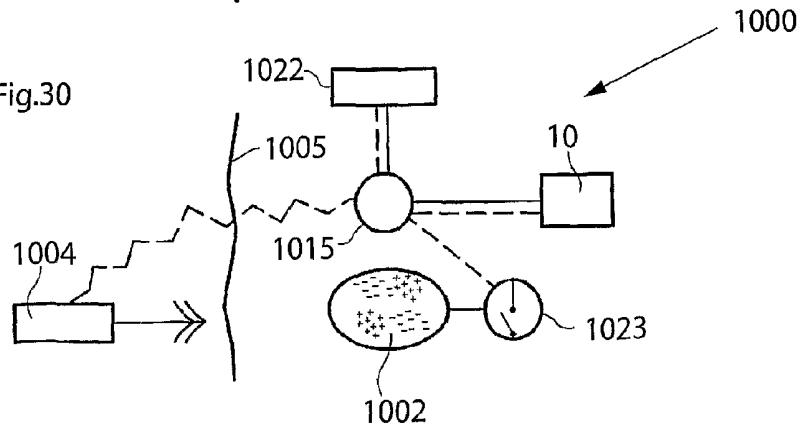

Fig.31

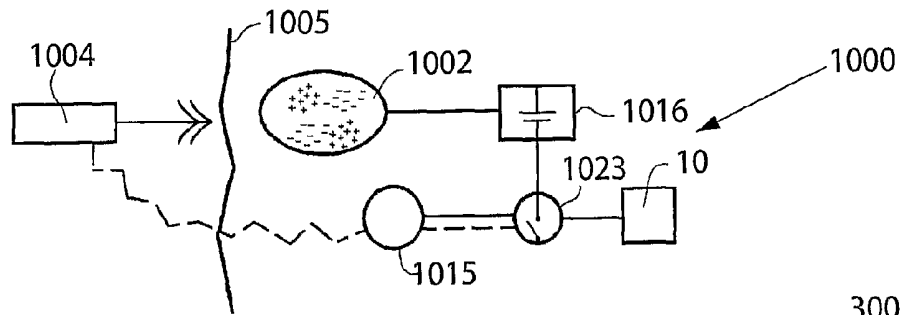

Fig.32

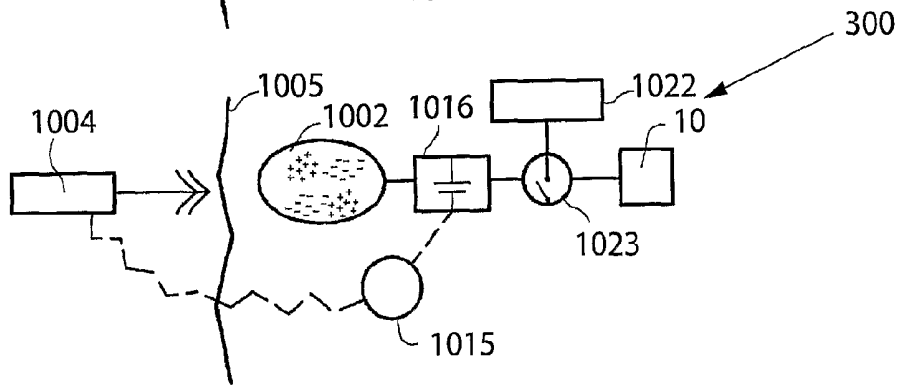

Fig.33

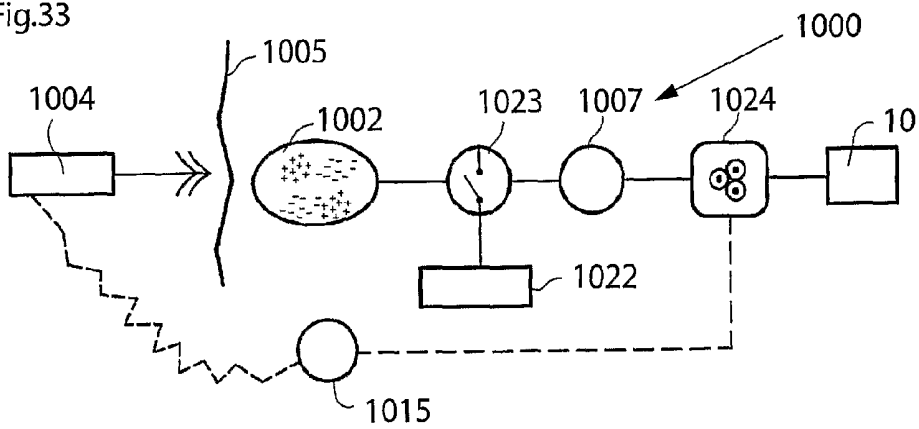

Fig.34

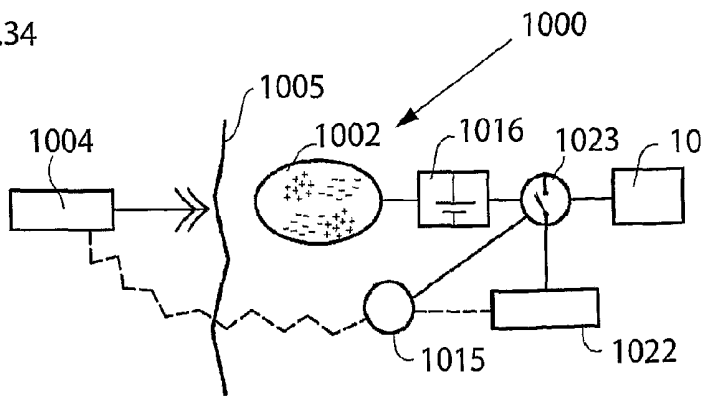

Fig.35

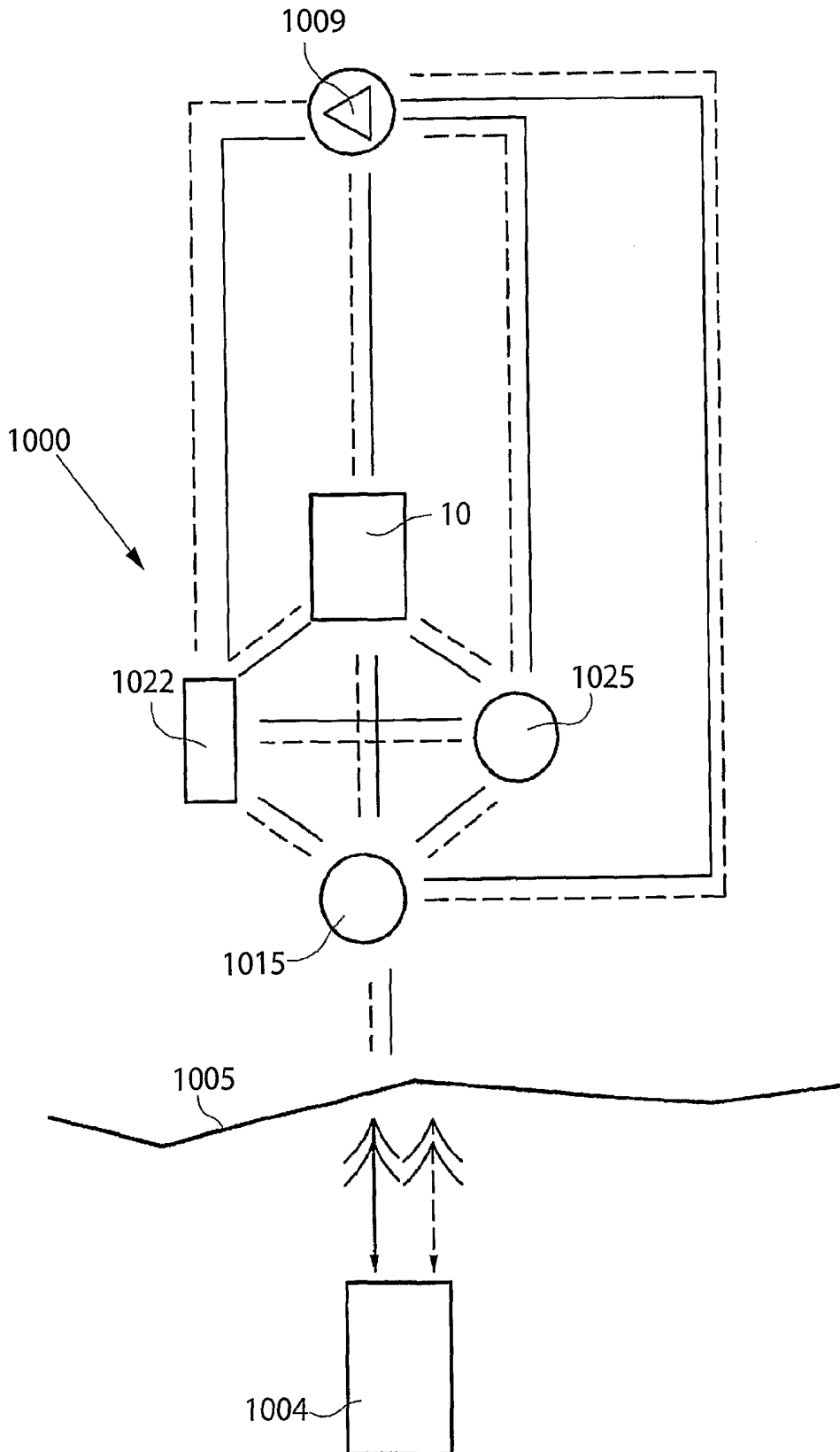

Fig.36

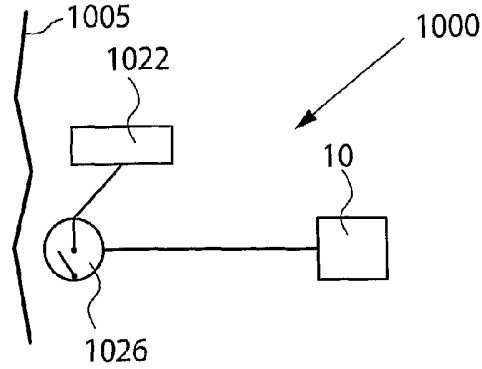

Fig.37

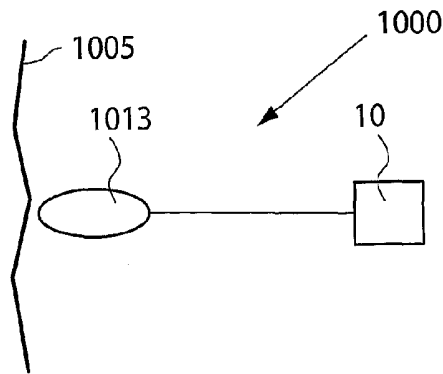

Fig.38

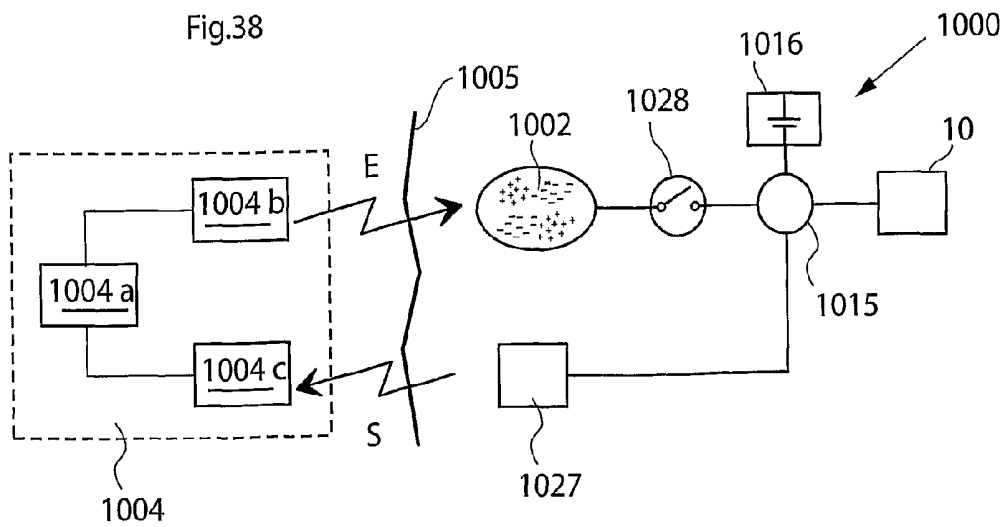

Fig.39

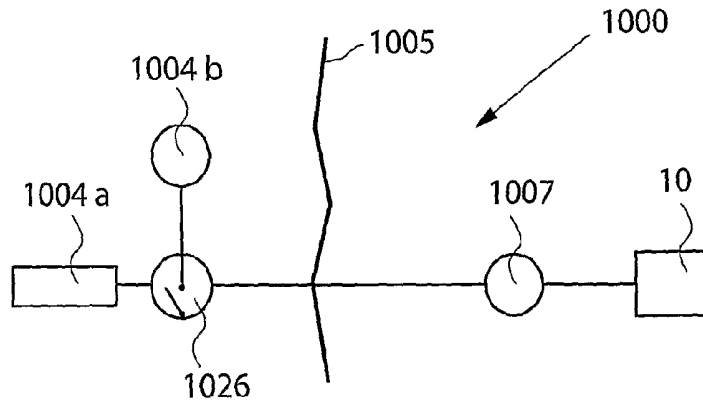

Fig.40

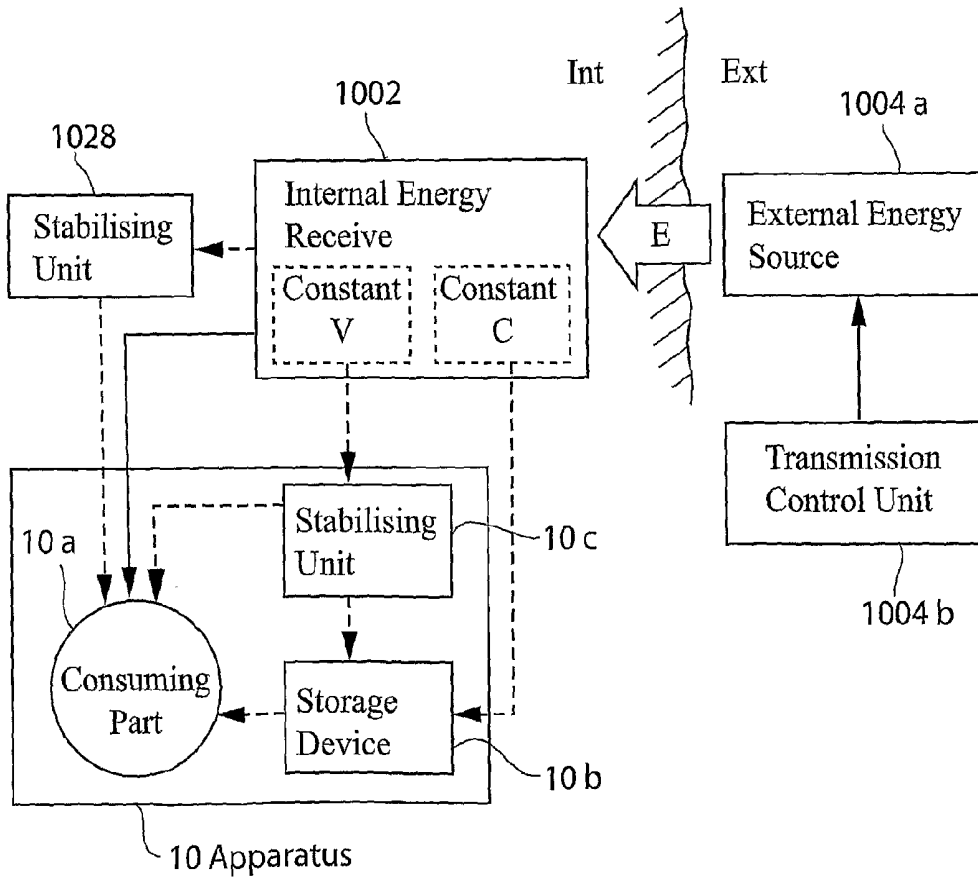

Fig.41

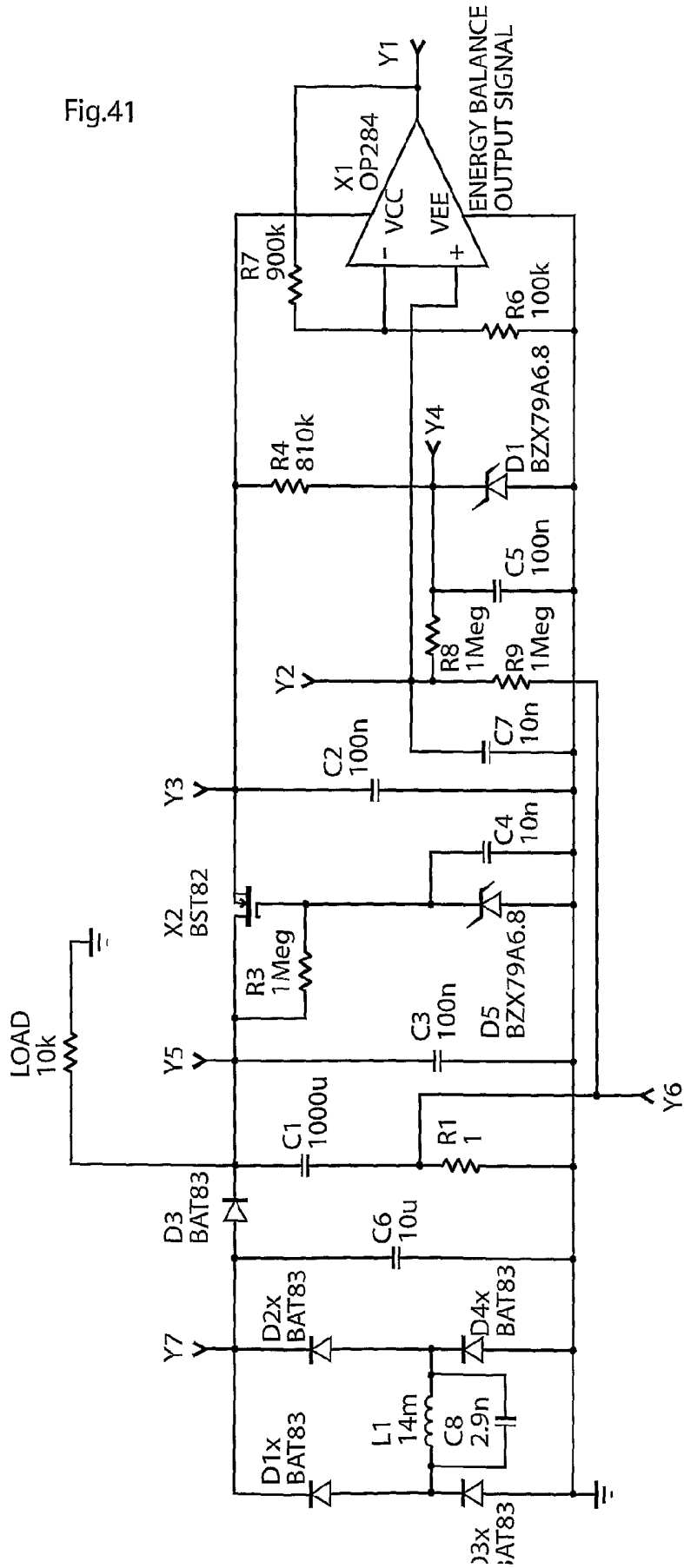

Fig.42

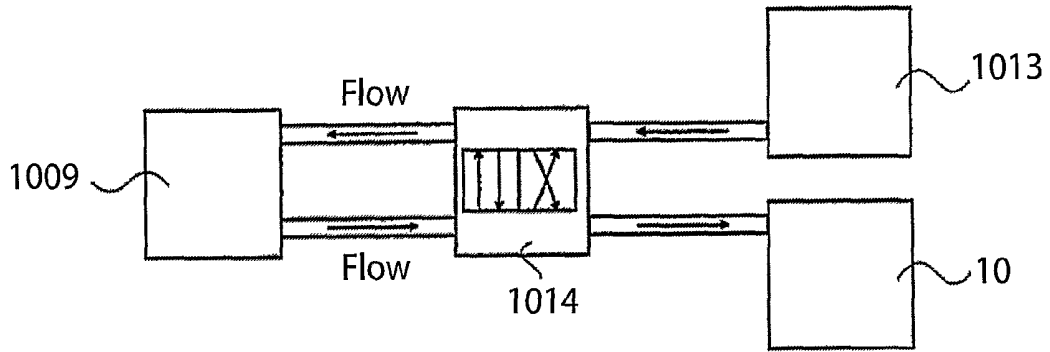

Fig.43

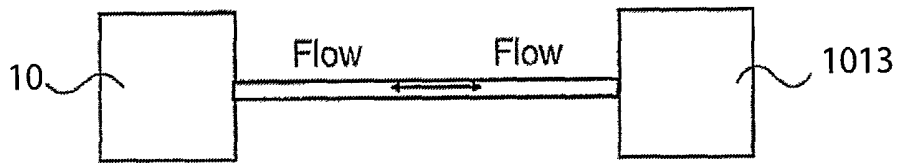

Fig.44

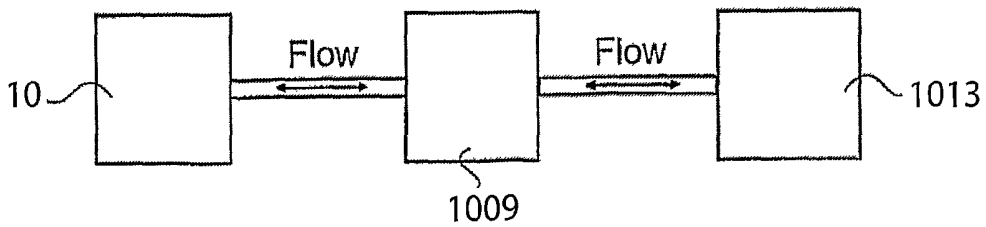

Fig.45

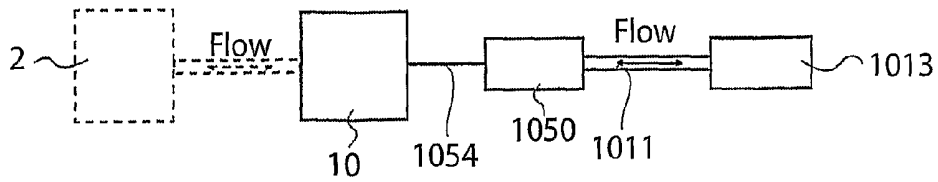

Fig.45 a

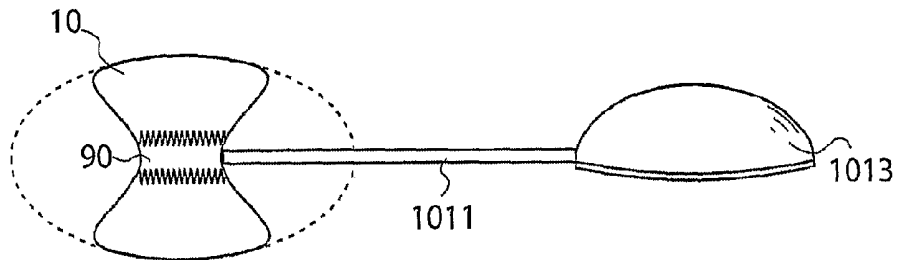

Fig.45 b

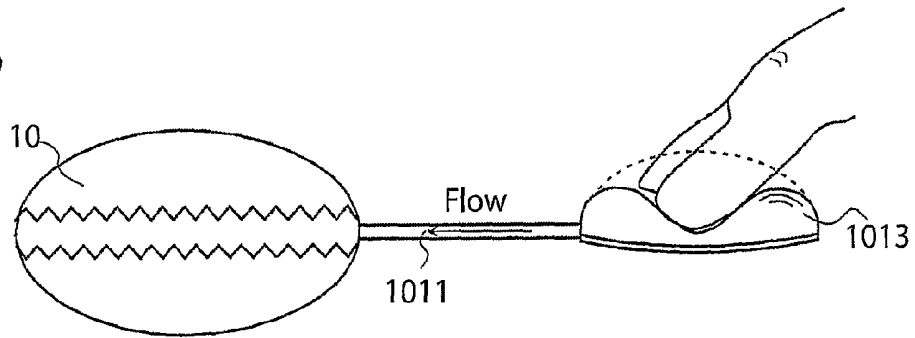

Fig.45 c

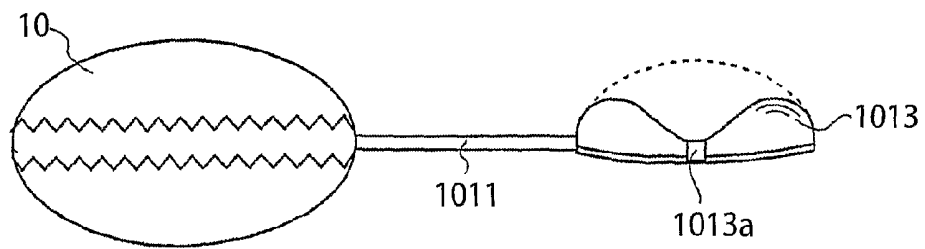

Fig.46

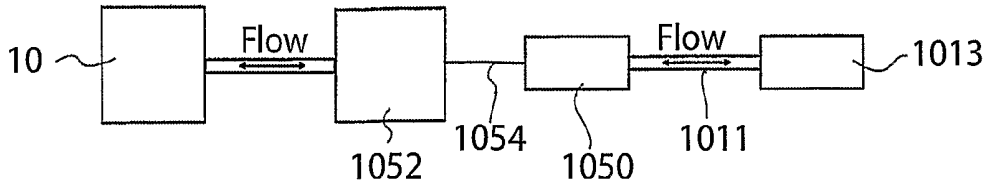

Fig.47 a

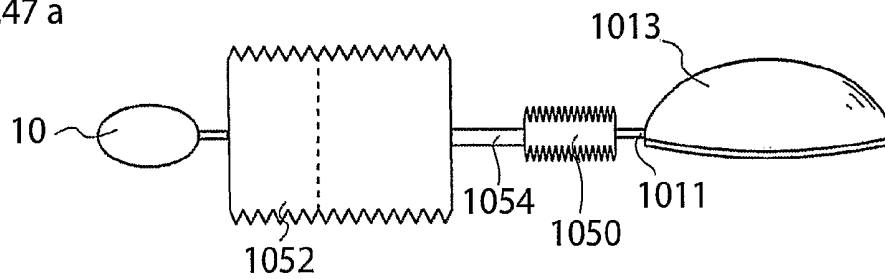

Fig.47 b

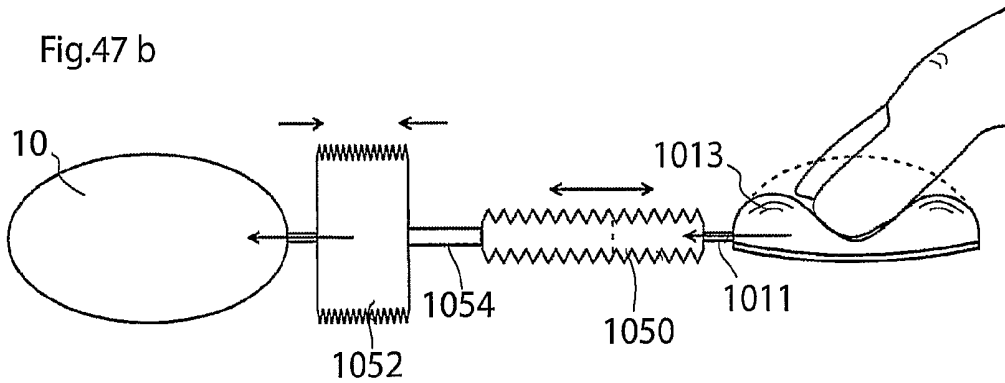

Fig.47 c

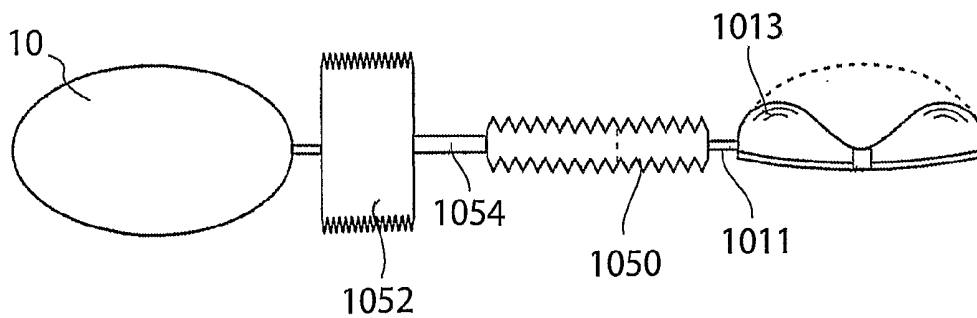
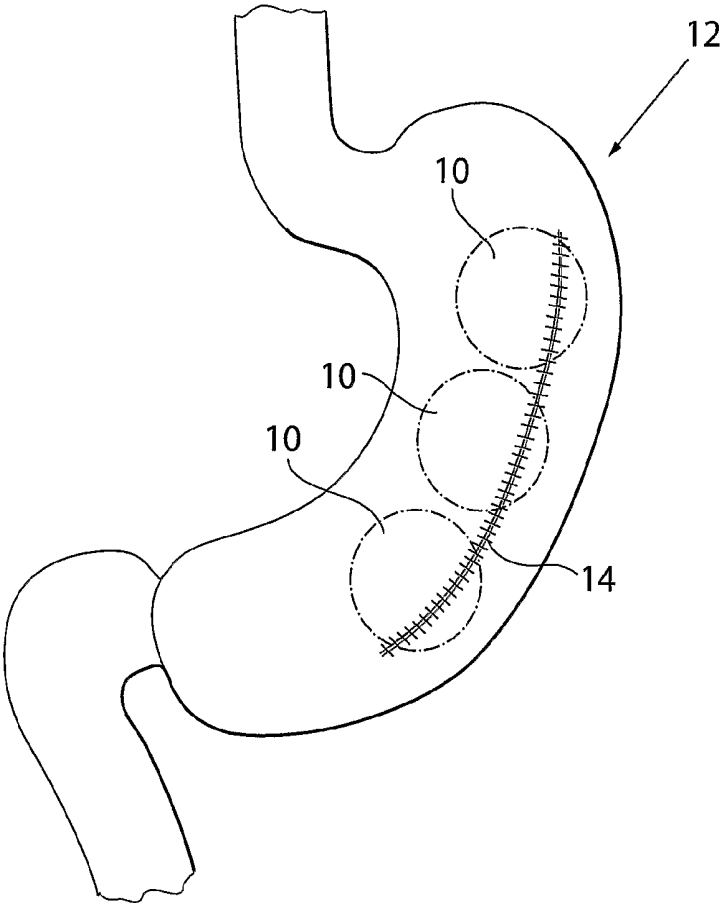

Fig.48



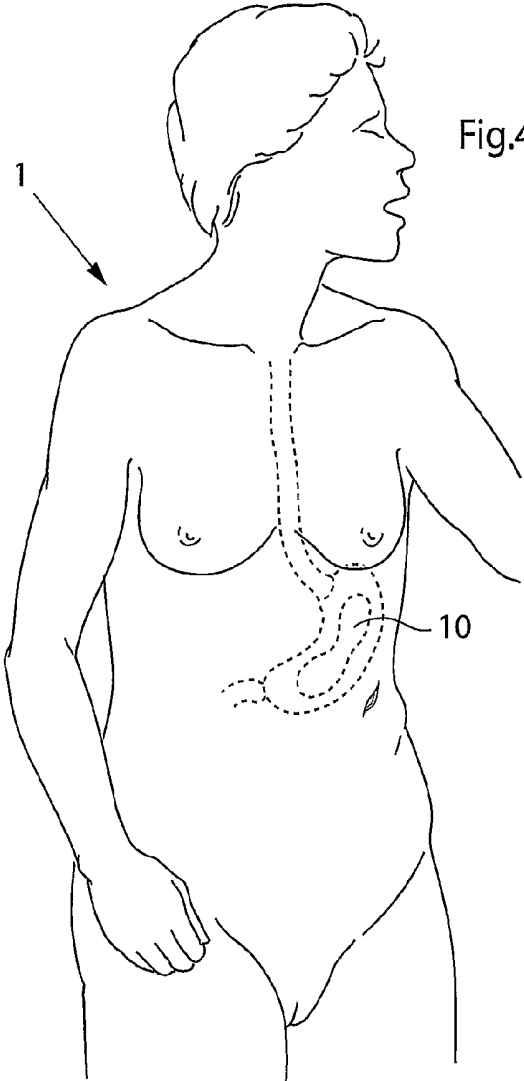

Fig.49a

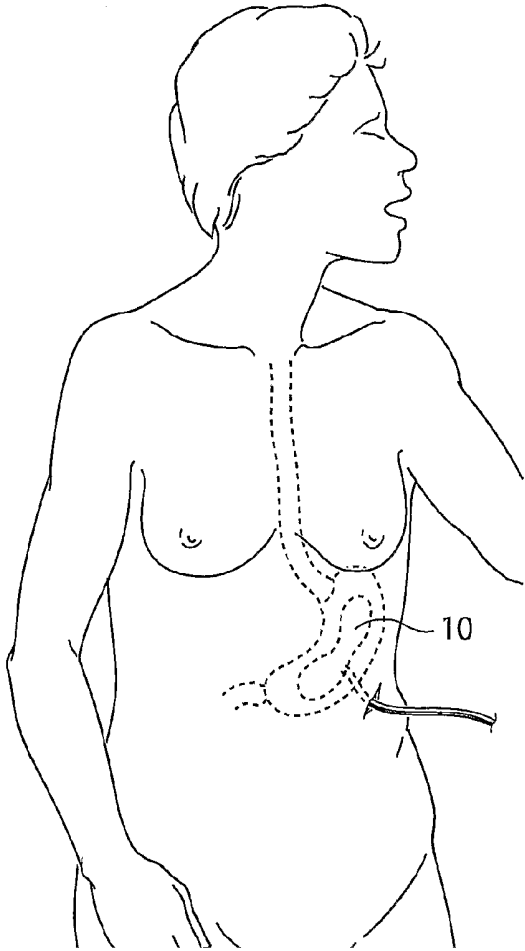

Fig.49b

METHODS AND INSTRUMENTS FOR TREATING OBESITY

This application is the U.S. national phase of International Application No. PCT/SE2009/000049, filed 29 Jan. 2009, which designated the U.S. and claims priority to SE Application No. 0802138-8, filed Oct. 10, 2008; and claims the benefit of U.S. Provisional No. 61/006,719, filed 29 Jan. 2008, the entire contents of each of which are hereby incorporated by reference.

TECHNICAL FIELD

The present invention relates to an apparatus, a system, and a method for treating obesity.

BACKGROUND

Obesity has been treated by gastric banding a band placed around the stomach to create a stoma, a restricted opening, to restrict the flow of food down to below the band. There has also been tried to use electrical stimulation of the stomach wall to cause the patient to feel satiety.

When the stomach gets distended the patient gets a feeling that the stomach is full.

Another prior art way of treating obesity is to insert a balloon-like object into the stomach of the patient. In this way, the patient is given the feeling of safety much more quickly when eating, preventing excessive intake of food. However, these prior art balloon-like objects are subject to stomach acids, leading to their destruction within a couple of months of use.

An example of a prior art inflatable gastric device for treating obesity is disclosed in U.S. Pat. No. 4,246,893 to Berson. In this document, it is disclosed an abdominal method wherein an inflatable balloon is surgically implanted in the abdominal cavity of the patient adjacent to the stomach. An adjusting port is provided subcutaneously and the balloon is subsequently inflated by means of inserting a hypodermic needle through the skin of the patient into the adjusting port and introducing a fluid under pressure into the port for passage into the balloon to distend the upper abdomen, compressing the stomach and thereby producing a sense of satiety.

SUMMARY

The object of the present invention to provide obesity treatment apparatus, system and methods with improved long term properties.

This object and others are obtained by an apparatus described in the appended claims.

In a first alternative embodiment, the volume filling device is implanted using a laparoscopic method instead of the intraluminal method described above. According to this embodiment, a needle or a tube-like instrument is inserted into the abdomen of the patient's body, and said needle or tube-like instrument is then used to fill the patient's abdomen with gas. Subsequently, at least two laparoscopic trocars are inserted into the patient's body; and a camera is inserted through one of said at least two laparoscopic trocars. Then, at least one dissecting tool through one of said at least two laparoscopic trocars, and an area of the stomach is dissected. The volume filling device is then introduced into the abdominal cavity, and placed on the outside of the stomach wall. A pouch in the stomach wall for the device is created, and the device invaginated in said pouch by providing stomach to stomach sutures or staples, thereby posi-

tioning the volume filling device so that the volume of the food cavity is reduced in size by a volume substantially exceeding the volume of the volume filling device.

The above first alternative preferably further comprises affixing the device to the stomach wall by providing sutures or staples. According to one embodiment, the stomach wall is affixed to the lower part of the patient's esophagus by providing sutures or staples. Alternatively, the stomach wall is affixed to the patient's diaphragm muscle or associated muscles.

The above embodiment preferably further comprises providing an apparatus for regulating the obesity treatment device from the outside of the patient's body; and operating said apparatus to regulate the obesity treatment device. Further, regulation of the obesity treatment device includes changing the volume of a filling body of the volume filling device when implanted.

The above embodiment preferably further comprises providing an injection type syringe comprising a fluid for injection into an implanted filling body; and injecting volume of fluid into said filling body.

According to an embodiment, the device is enclosed in the pouch or partially enclosed in that the pouch is left at least partly open. Further, the pouch can be designed to exhibit only one opening. Alternatively the pouch is designed to exhibit two openings and to extend non-circumferentially around the stomach.

Preferably the pouch has a volume of more than 15 milliliters.

In a second alternative, also using a laparoscopic method instead of the intraluminal method, the initial steps are the same as described in the first alternative, but following dissection of the stomach, a hole is created in the stomach wall and a volume filling device introduced into the abdominal cavity and through said hole into the stomach. The device is placed on the inside of the stomach wall, and a pouch is created on the outside of the stomach cavity for the device placed on the inside of the stomach wall, and the device is invaginated in the pouch by providing stomach to stomach sutures or staples, thereby positioning the volume filling device so that the volume of the food cavity is reduced in size by a volume substantially exceeding the volume of the volume filling device.

The above embodiment preferably further comprises affixing the device to the stomach wall by providing sutures or staples. According to one embodiment, the stomach wall is affixed to the lower part of the patient's esophagus by providing sutures or staples. Alternatively, the stomach wall is affixed to the patient's diaphragm muscle or associated muscles.

The above second alternative preferably further comprises providing an apparatus for regulating the obesity treatment device from the outside of the patient's body; and operating said apparatus to regulate the obesity treatment device. Further, regulation of the obesity treatment device includes changing the volume of a filling body of the volume filling device when implanted.

The above embodiment preferably further comprises providing an injection type syringe comprising a fluid for injection into an implanted filling body; and injecting volume of fluid into said filling body.

According to an embodiment, the device is enclosed in the pouch or partially enclosed in that the pouch is left at least partly open. Further, the pouch can be designed to exhibit only one opening. Alternatively the pouch is designed to exhibit two openings and to extend non-circumferentially around the stomach.

Preferably the pouch has a volume of more than 15 milliliters.

A third alternative involves a surgical incision instead of either the intraluminal or the laparoscopic method. Here, an opening in the patient's abdominal wall is made by surgical incision, and an area of the patient's stomach is dissected. The volume filling device is introduced through said abdominal incision, and attached to the stomach wall, thereby positioning the volume filling device so that the volume of the food cavity is reduced in size by a volume substantially exceeding the volume of the volume filling device.

In an alternative embodiment of the above, third alternative, the initial steps are the same including the dissection of an area of the stomach. Following this, a pouch in the stomach wall is created for the device, and the device invaginated in the pouch by providing stomach to stomach sutures or staples, thereby positioning the volume filling device so that the volume of the food cavity is reduced in size by a volume substantially exceeding the volume of the volume filling device.

In yet another alternative embodiment of the above, third alternative, the initial steps are the same including the dissection of an area of the stomach. Following this, a hole in the stomach wall is created and the volume filling device introduced through the hole and into the stomach. The device is then placed on the inside of the stomach wall, and a pouch on the stomach wall created for the device. The device is then invaginated in the pouch by providing stomach to stomach sutures or staples, thereby positioning the volume filling device so that the volume of the food cavity is reduced in size by a volume substantially exceeding the volume of the volume filling device.

The above embodiments of the third alternative further comprise affixing the device to the stomach wall by providing sutures or staples.

According to one embodiment, the stomach wall is affixed to the lower part of the patient's esophagus by providing sutures or staples. Alternatively, the stomach wall is affixed to the patient's diaphragm muscle or associated muscles.

The above embodiment preferably further comprises providing an apparatus for regulating the obesity treatment device from the outside of the patient's body; and operating said apparatus to regulate the obesity treatment device. Further, regulation of the obesity treatment device includes changing the volume of a filling body of the volume filling device when implanted.

The above embodiment preferably further comprises providing an injection type syringe comprising a fluid for injection into an implanted filling body; and injecting volume of fluid into said filling body.

According to an embodiment, the device is enclosed in the pouch or partially enclosed in that the pouch is left at least partly open. Further, the pouch can be designed to exhibit only one opening. Alternatively the pouch is designed to exhibit two openings and to extend non-circumferentially around the stomach.

Preferably the pouch has a volume of more than 15 milliliters.

A fourth alternative embodiment is a method comprising the steps of inserting a needle or a tube-like instrument into the abdomen of the patient's body; using said needle or tube-like instrument to fill the patient's abdomen with gas; placing at least two laparoscopic trocars in the patient's body; inserting a camera through one of said at least two laparoscopic trocars into the patient's abdomen; inserting at least one dissecting tool through one of said at least two laparoscopic

trocars; dissecting an area of the stomach; creating a pouch from the stomach wall for the device; closing the pouch by providing sutures and staples;

introducing an injecting member comprising an injectable filling material; and

injecting the filling material into the pouch, thereby creating a filling body that fills a volume in the patient's stomach, reducing the food cavity in size by a volume substantially exceeding the volume of the volume filling device.

10 Instead of the above disclosed laparoscopic method, a surgical incision or opening is cut in the skin to enter the patient's abdomen; an area of the stomach dissected; a pouch created from the stomach wall for the device; and said pouch closed by providing sutures and staples. An injecting member comprising an injectable filling material is then introduced; and the filling material injected into the pouch, thereby creating a filling body that reduces the food cavity in size by a volume substantially exceeding the volume of the volume filling device.

20 According to an alternative embodiment of the above, the pouch is created on the outside of the stomach wall, with the filling body placed against the inside of the stomach wall.

The method according to either of the two previous embodiments comprises creating a hole in the stomach wall wherein the pouch is created on the inside of the stomach wall, with the filling body placed against the outside of the stomach wall.

The method according to either of the two previous embodiments may further comprise affixing the stomach wall to the lower part of the patient's esophagus by providing sutures or staples or affixing the stomach wall to the patient's diaphragm muscle or associated muscles.

Preferably the pouch has a volume of more than 15 milliliters.

35 In a method according to either of the two previous embodiments the filling material is preferably capable of undergoing a curing process from a fluid state to a semi-solid or solid state. Preferably said curing process is triggered by an increase in temperature from ambient temperature to body temperature.

Alternatively the curing process is triggered by a ultraviolet or any other electromagnetic radiation or by a an interaction in the injected substances.

The invention also makes available a method of treating obesity in a patient by implanting a volume filling device that, when implanted in a patient, reduces the food cavity in size by a volume substantially exceeding the volume of the volume filling device, the method comprising the steps of:

inserting a needle or a tube-like instrument into the abdomen of the patient's body;

using said needle or tube-like instrument to fill the patient's abdomen with gas;

placing at least two laparoscopic trocars in the patient's body; inserting a camera through one of said at least two laparoscopic trocars into the patient's abdomen;

inserting at least one dissecting tool through one of said at least two laparoscopic trocars;

dissecting an area of the stomach;

creating a hole in the stomach wall; introducing a device into the abdominal cavity;

introducing the device through the hole and into the stomach;

placing the device on the outside of the stomach wall; fixating the device placed on the outside of the stomach wall, and

65 thereby creating a filling body that reduces the food cavity in size by a volume substantially exceeding the volume of the volume filling device.

In the above method, the device is preferably affixed to the stomach wall by providing sutures or staples.

The invention also comprises a laparoscopic instrument for providing a volume filling device to be invaginated in the stomach wall of a human patient to treat obesity, suitable for use with any of the laparoscopic methods described above, the instrument comprising:

an elongated member having a proximal end and a distal end, the elongated member having a diameter less than that of a laparoscopic trocar to be introduced into the patients abdomen during a laparoscopic operation;

a stomach pushing device for pushing the stomach wall to create a tube-like shaped portion of the stomach wall protruding into the normal stomach cavity, said pushing device comprising the volume filling device to be invaginated by the stomach wall in the tube-like shaped portion thereof;

wherein the pushing device comprises a vacuum device to suck the stomach to assist the instrument in forming the tube-like shaped portion of the stomach wall together with the pushing device, and wherein the vacuum device comprises a vacuum passageway leading from the proximal to the distal end of the instrument and at the end portion of the instrument, which includes the pushing device, said vacuum passageway is divided up in multiple small openings adapted to suck the stomach wall portion to become adherent to the pushing device to further form the tube-like stomach wall portion; and wherein the instrument comprises an insertion device adapted to introduce the volume filling device into the tube-like shaped stomach portion.

This instrument preferably comprises at least one clamping device for holding the opening of the tube-like portion substantially closed by clamping together stomach to stomach in said opening, wherein the instrument is adapted to place the at least one clamping device at the opening in such a way that it allows later suturing of the opening.

Further, the instrument preferably comprises an inflation device for inflating the volume filling device before or after the suturing. Further still, the instrument preferably comprises a suturing device adapted to suture the opening of the tube-like portion with stomach to stomach sutures for creating at least partly a closed space enclosing the volume filling device, wherein the instrument is adapted to be withdrawn leaving the volume filling device at least partly invaginated in the stomach wall.

Said suturing device preferably comprises a first and second suture positioning member provided on the elongated member situated in the stomach at the distal end thereof, and wherein the instrument further comprises an operation device adapted to adjust the first and second suturing member in a position in which the first and second suture positioning members are in front of each other with the stomach wall on both sides of the open end of the cup like portion, and adapted to suture the open end of the cup like portion of the wall with a row of stomach to stomach sutures.

Preferably said suturing device comprises an operable reloadable multi-suturing device, which is reloadable with sutures from outside of the patient's body and which is adapted to suture the open end of the cup like portion of the wall with said row of stomach to stomach sutures, wherein the row of sutures comprises two or more sutures or staples to be sutured simultaneously.

More preferably, said suturing device comprises multiple sutures for suturing two or more sutures simultaneously.

Another embodiment of an instrument comprise laparoscopic instrument for implanting a volume filling device in a human patient to treat obesity, the instrument comprising:

an elongated member having a proximal end and a distal end, the elongated member being adapted to be introduced into the patients abdomen during a laparoscopic operation by means of a laparoscopic trocar,

a stomach pushing device adapted to create a recess in the stomach wall, the pushing device being adapted to place a volume filling device in the recess for subsequent invagination in the stomach wall.

Preferable the elongated member has a diameter of less than 30 millimeters.

The stomach pushing device may comprise a mechanical device or a vacuum sucking device adapted to suck the stomach wall to form the recess in the stomach wall, wherein the vacuum sucking device comprises a vacuum passageway leading from the proximal to the distal end of the instrument and at the end portion of the instrument.

In one embodiment the vacuum passageway exhibits a plurality of openings adapted to suck the stomach wall portion so that it adheres to the pushing device.

Furthermore the instrument may include an insertion device adapted to introduce the volume filling device into the recess.

Furthermore the instrument may include at least one clamping device for holding an opening of the recess substantially closed by clamping together portions of the stomach wall in said opening,

wherein the instrument is adapted to place the at least one clamping device at the opening of the recess to allow subsequent suturing of the opening.

Preferable the instrument comprises an inflation device for inflating the volume filling device when it has been placed in the recess.

In one embodiment the instrument further comprising a suturing device adapted to suture the opening of the recess with stomach to stomach sutures for creating at least partly a closed space enclosing the volume filling device, wherein the suturing device preferable comprises multiple sutures for simultaneous suturing of two or more sutures, wherein the instrument is adapted to be withdrawn leaving the volume filling device at least partly invaginated in the stomach wall.

The instrument may include in the suturing device a first and a second suture positioning member provided on the elongated member at the distal end thereof, and

an operation device adapted to adjust the first and second suturing members in a position in which the first and second suture positioning members are in front of each other with the stomach wall on both sides of the open end of the cup like portion, and adapted to suture the open end of the cup like portion of the stomach wall with a row of stomach to stomach sutures, wherein the suturing device preferable comprises a reloading device adapted to reload the suturing device from outside the patient's body.

The instrument is preferable suturing an open end of a cup like portion of a stomach wall with a row of stomach to stomach sutures.

BRIEF DESCRIPTION OF THE DRAWINGS

The present invention will now be described in more detail by way of non-limiting examples and with reference to the accompanying drawings, in which:

FIG. 1 is an overall view of a patient showing the outlines of the stomach,

FIG. 2a is a view of a first embodiment of an apparatus for treating obesity implanted in a human patient,

FIG. 2*b* is a sectional view taken along line II*b*-II*b* of FIG. 2*a*,

FIGS. 3*a-k*, 3*m*, 3*n*, and 3*p* show different shapes and features of a volume filling device comprised in an apparatus according to the invention,

FIGS. 4*a-d* show a deflated inflatable volume filling device comprised in an apparatus according to the invention and an instrument for placing the volume filling device,

FIGS. 5*a-i* illustrate different steps of invaginating the inflatable device of FIG. 4*a* on the outside of a stomach wall of a patient,

FIGS. 6-8 show alternative embodiments wherein the volume filling device is adapted to be non-invasively adjustable postoperatively,

FIGS. 9 and 10 show embodiments wherein the volume filling device is adapted to be invaginated in the fundus region of the patient's stomach,

FIG. 11 shows an embodiment wherein the volume filling device is also adapted to treat reflux,

FIG. 12 show an embodiment wherein the volume filling device adapted also for treating reflux is combined with stretching devices for stretching part of the stomach fundus wall,

FIGS. 13-16 show alternative embodiments wherein a combination of a volume filling device and a stretching device is used,

FIGS. 17*a* and 17*b* show an embodiment wherein the volume filling device is provided on the inside of the stomach wall,

FIGS. 18*a-h* illustrate different steps of invaginating the inflatable device of FIG. 4*a* on the inside of a stomach wall of a patient,

FIGS. 19*a-j* illustrate different steps of invaginating the inflatable device of FIG. 4*a* on the inside of a stomach wall of a patient,

FIGS. 20*a-f* illustrate different steps of invaginating the inflatable device of FIG. 4*a* on the inside of a stomach wall of a patient,

FIG. 21*a* shows an instrument used in a method of engaging a volume filling device to a stomach wall and FIG. 21*b* shows an instrument comprising an elongated member after a cutting operation has been performed and a stomach penetrating member or cutter has been retracted into a protective sleeve.

FIG. 22 is an overall view of a patient with an implanted apparatus for treating obesity,

FIGS. 23-41 show various ways of powering an apparatus for treating obesity implanted in a human patient,

FIGS. 42-47 show various ways of arranging hydraulic or pneumatic powering of an apparatus for treating obesity implanted in a human patient,

FIG. 48 illustrate the invagination of a plurality volume filling devices, and

FIGS. 49*a* 49*b* illustrate an abdominal method.

DETAILED DESCRIPTION OF PREFERRED EMBODIMENTS

Preferred embodiments of the invention will now be described in detail with reference to the drawing figures.

FIG. 1 shows a human patient 1, who is being treated for obesity. A volume filling device 10 is provided so that it reduces the inner volume of the stomach 12—the food cavity of the stomach, thereby affecting the patient's appetite. The function and the operation of this volume filling device will be described and explained in detail in the following description.

FIGS. 2*a* and 2*b* show in detail a first embodiment of an apparatus to treat obesity according to the invention, wherein FIG. 2*a* show a side view of the stomach while FIG. 2*b* is a sectional view taken along line II*b*-II*b* of FIG. 2*a*. The apparatus comprises a volume filling device 10 implanted in a human patient. More specifically, in the embodiment of FIG. 2*a* the volume filling device 10 is invaginated in the wall 12*a* of the patient's stomach 12 on the outside of the stomach wall. The body of the volume filling device 10 is elongated and shaped to rest against the wall 12*a* of the stomach 12 and further has an outer surface suitable to rest against this wall.

By invaginating the volume filling device 10 in part of the stomach wall, the size of the food cavity, generally designated 12*b* in FIG. 2*b*, will be reduced, resulting in a more rapid feeling of satiety after food intake.

The volume filling device 10 preferably comprises an elastic material, such as silicone. In this way, the volume filling device can adapt to the movements of the stomach, the degree of food intake etc.

By providing the volume filling device from a bio-compatible material, the risk of the patient's body rejecting the implant is to a very large extent reduced.

The volume filling device 10 can be fixed to the wall 12*a* of the stomach 12 in a number of different ways. In the embodiment shown in FIG. 2*b*, the volume filling device 10 is invaginated in the stomach wall 12*a*. After invagination, a number of stomach-to-stomach sutures or staples 14 are applied to keep the invagination in the short term. This allows growth of human tissue, keeping the invagination in the long term.

The volume filling device 10 preferably has an essentially round shape to not damage the stomach wall. An example thereof is shown in FIG. 3*a*, wherein the volume filling device is essentially egg-shaped. In another preferred embodiment, the volume filling device is slightly bent, such as the embodiment shown in FIG. 3*b*. However, since the stomach wall is strong many different shapes, forms, and dimensions may be used. In one embodiment, the volume filling device has a diameter of about 40 millimeters and a length of about 120 millimeters, resulting in a volume that is about half the volume of the patient's stomach. However, it is preferred that the maximum circumference of the volume filling device is at least 30 millimeters, more preferably at least 50 millimeters, and even more preferably at least 80 millimeters.

It is not necessary that the volume filling device is elongated. In the embodiment shown in FIG. 3*c*, the volume filling device 10 is essentially spherical or ball-shaped. In order to fill out the stomach, two or more such volume filling devices may be combined to achieve the desired decrease of the food cavity of the patient's stomach.

It has been mentioned that the volume filling device is secured by the stomach-to-stomach sutures or staples. In order to further improve the fixation, the volume filling device may be provided with a waist portion having smaller diameter than the maximum diameter of the volume filling device. Such volume filling device having a waist portion 10*a* is shown in FIG. 3*d*.

The volume filling device 10 may consist of at least two interconnectable portions so that each portion is easier to insert into the stomach and further through a hole in the stomach wall. Thus, FIG. 3*e* shows a volume filling device comprising two more or less spherical sub-parts 10*b*, 10*c* interconnected by a portion with which preferably has smaller diameter. The portion with smaller diameter may comprise an interconnection means with a reversible function allowing subsequent disconnection of the two interconnected sub-parts 10*b*, 10*c*. Such means may comprise a bayonet socket, a screw connection or the like, designated 10*d* in the

figure. Alternatively, the portion with smaller diameter may comprise a fixed interconnection, such as resilient locking hooks provided on one of the sub-parts **10b**, **10c** and engaging the rim of a hole provided in the other one of the sub-parts **10b**, **10c**.

The configuration of the volume filling device **10** is not limited to one waist portion **10a**. Thus, in FIG. **3f** a volume filling device with two waist portions is shown.

In order to facilitate positioning of the volume filling device, an attachment means in the form of a handle or the like may be provided on the outer surface of the volume filling device. One example thereof is shown in FIG. **3g**, wherein also a detail view of a handle **10e** is shown. In a preferred embodiment, the attachment means is provided at an end portion of the volume filling device **10**. In order to avoid protruding portion on the surface of the volume filling device **10**, the handle **10e** is provided flush with the outer surface of the volume filling device **10** and a recess **10f** is arranged to allow a gripping tool or instrument (not shown in FIG. **3g**) to achieve fit in gripping around the handle **10e**.

The volume filling device may comprise a tube for filling or emptying the volume filling device of a fluid or gel. By injecting fluid or gel into the volume filling device **10**, the volume filling device is inflated to an inflated state, as will be described below. The size of the volume filling device can also be adjusted by moving fluid or gel therefrom to a different reservoir.

A volume filling device **10** adapted for this is shown in FIG. **3h**. A tube **10g** is fixedly attached to the volume filling device. This tube can be attached to a suitable instrument (not shown) or an injection port, which will be explained in detail below.

Instead of having a fixedly attached tube, the volume filling device **10** may comprise an inlet port **10h** adapted for connection of a separate tube (not shown in this figure).

It is important that the implanted volume filling device is firmly kept in place in the stomach wall in which it is invaginated. To this end, the volume filling device can be provided with one or more through holes adapted for receiving sutures or staples used for fixation of the invagination. Such an embodiment is shown in FIG. **3j**, where the volume filling device **10** is provided with a row of holes **10i** provided on a protruding flange-like protrusion on the volume filling device. In this embodiment, the row of holes extend along the longitudinal axis of the volume filling device.

FIG. **3k** illustrates how sutures **14** are provided so that they run through the stomach wall **12a** and through the holes **10i**. In this way, the volume filling device is fixed in place in the pouch created from the stomach wall and will thus be prevented from sliding.

Although a plurality of holes is illustrated in the FIG. **3j**, it will be appreciated that one single hole is sufficient to obtain improved fixation of the volume filling device **10**.

FIG. **3m** illustrates a volume filling device provided with an inlet port **10h**. The volume filling device is invaginated in the stomach wall and the inlet port **10h** is available for connection to a tube or the like from the abdominal area of the patient.

FIG. **3n** illustrates an invaginated volume filling device wherein, instead of an inlet port, a fixed tube **10g** extends into the abdominal area of the patient.

FIG. **3p** is a figure similar to FIG. **3m** but also illustrating tunneling of a connection tube **10g** in the stomach wall between the inlet port **10h** and the volume filling device **10**.

It has been shown that the shape of the volume filling device can take many different forms. It will be appreciated that also the material of the volume filling device can vary. It is preferred that the volume filling device is provided with a coating, such as a Parylene, polytetrafluoroethylene (PTFE),

or polyurethane coating, or a combination of such coatings, i.e., a multi-layer coating. This coating or multi-layer coating improves the properties of the volume filling device, such as its resistance to wear.

In one embodiment, the volume filling device comprises an inflatable device expandable to an expanded state. In this case, the inflatable device is provided with an inlet port for a fluid and is adapted to be connected to a gastroscopic instrument. This embodiment will now be described in detail with reference to FIGS. **4a-4d**.

An inflatable volume filling device in its non-expanded state is shown in FIG. **4a**. It is essentially a balloon-like, deflated device **10** having an inlet port **10h**. In this state, the inflatable device has a diameter of a few millimeters at the most, allowing it to be inserted into the stomach through the esophagus of the patient by means of a gastroscopic, tube-like instrument **600**, depicted in FIG. **4b**. The instrument comprises an outer sleeve **600a** and an inner sleeve **600b** which can be displaced longitudinally relatively to the outer sleeve. The inner sleeve is provided with a cutter in the form of a cutting edge **615** at the distal end thereof. This cutting edge can be used for cutting a hole in the stomach wall, as will be explained in detail in the following.

When the instrument reaches a stomach wall, see FIG. **4c**, the inner sleeve is brought forward from its position in the outer sleeve and into contact with the stomach wall **12a**. The cutting edge **615** of the inner sleeve then cuts a hole in the stomach wall so as to allow subsequent insertion of the volume filling device **10** into and through this hole, see FIG. **4d**. In order to push the volume filling device through the hole, a piston **602** may be provided in the instrument. Thus, the instrument further comprises a piston **602** adapted for pushing a deflated volume filling device **10** out from a position in the inner sleeve, this position being shown in FIG. **4b**, to a position outside of the inner sleeve, this being shown in FIG. **4d**.

In order to protect the deflated volume filling device **10** from the cutting edge **615** of the inner sleeve, a further protective sleeve (not shown) can be provided around the volume filling device.

An intraluminal method of invaginating a volume filling device **10** on the outside of the stomach wall **12a** will now be described with reference to FIGS. **5a-i**. Initially, an instrument **600**, preferably a gastroscopic instrument, is inserted into the mouth of the patient, see FIG. **5a**. The instrument comprises an injection device **601**, **602** for injecting either fluid or a device into the stomach of the patient. The instrument **600** further comprises a control unit **606** adapted for controlling the operation of the instrument. To this end, the control unit **606** comprises one or more steering devices, in the embodiment shown in the figure in the form of two joysticks **603** and two control buttons **604**. A display **605** is provided for displaying the image provided by an optical device for viewing inside the stomach, such as a camera (not shown) arranged at the outer end of the elongated member **607**, see FIGS. **5e-i**. The camera, which may comprise connecting electrical wires extending along the elongated member, may be assisted by a light source (not shown) placed distally on the elongated member for illuminating the inside of the stomach. The optical device may also comprise optical fibers placed along the elongated member and leading out from the patient's body for external viewing of the inside of the stomach.

The instrument is further inserted into the esophagus and into the stomach of the patient, see FIG. **5b**. By means of the instrument **600**, a hole **12b** is created in the wall of the stomach **12**. To this end, the instrument is provided with one or

more cutters **615** at the distal end thereof, for example in the way described above with reference to FIGS. *4a-d*. These cutters can of course be designed in different ways, such as a toothed drum cutter rotating about the center axis of the tube-like instrument.

After cutting a hole in the stomach wall, the distal end of the instrument **600** is inserted into and through the hole **12b** so that it ends up outside the stomach wall **12a**. This is shown in FIG. *5c*, showing a side view of the stomach **12**, and FIG. *5d*, which is a sectional view through the stomach of FIG. *5c* taken along the lines Vd-Vd.

The instrument **600** is adapted to create a "pocket" or "pouch" on the outside of the stomach **12** around the hole **12b** in the stomach wall. Such an instrument and the method of providing the pouch will now be described.

FIGS. *5e-i* show a gastroscopic or laparoscopic instrument for invaginating a volume filling device **10** in the stomach wall **12a** of the patient by creating a pouch of stomach wall **12a** material in which the volume filling device is placed. The instrument, generally designated **600**, and which may comprise the features described above with reference to FIGS. *4a-d*, comprises an elongated member **607** having a proximal end and a distal end, the elongated member **607** having a diameter less than that of the patient's esophagus and being flexible such as to allow introduction of the flexible elongated member **607** with its distal end first through the patient's throat, esophagus and into the stomach **12** to the stomach wall **12a**.

The stomach penetration device or cutter **615** is provided on the elongated member **607** at the distal end thereof for penetrating the stomach wall **12a** so as to create a hole in the stomach wall **12a**, to allow introduction of the elongated member **607** through the hole. The stomach penetration device **615** could be adapted to be operable for retracting said stomach penetration device **615** after the stomach fundus wall **12a** has been penetrated, for not further damaging tissue within the body. The instrument further comprises a special holding device **609** provided on the elongated member **607** on the proximal side to the penetration device **615**.

The elongated member further comprises an expandable member **611** which is adapted to be expanded after the elongated member has penetrated the stomach wall **12a** and thereby assist in the creation of a cavity or pouch adapted to hold the volume filling device **10**. The expandable member **611** may comprise an inflatable circular balloon provided circumferentially around the distal end portion of the flexible elongated member **607**.

The method steps when invaginating the volume filling device will now be described in detail. After the instrument **600** has been inserted into the stomach **12**, the stomach penetration device **615** is placed into contact with the stomach wall **12a**, see FIG. *5e*. The stomach penetration device or cutter **615** is then brought to create the hole **12b** in the stomach wall, whereafter at least the expandable member **611** is brought through the hole **12b** in the stomach wall. The special holding device **609** is in this step brought to a holding state wherein it expands radially so as to form an essentially circular abutment surface to the stomach wall **12a**, see FIG. *5f*. In this way, the insertion of the stomach penetration device **615** and the expandable member **611** through the hole **12a** in the stomach wall is limited to the position shown in FIG. *5f*.

The expandable member **611** is then expanded. In the case the expandable member comprises a balloon or the like, air or other fluid is injected into it.

The part of the elongated member **607** comprising the expandable member **611** is then retracted in the proximal direction, as indicated by the arrow in FIG. *5g*, thereby pull-

ing the stomach wall **612** into a basket or cup like structure created by the special holding device **609**.

A suturing or stapling device **608** is further provided, either as a device connected to the elongated member **607** or as a separate instrument. The suturing or stapling member comprises a suturing or stapling end **613** which is adapted to close the cavity or pouch by means of stomach to stomach sutures or staples **14**.

In a further step, illustrated in FIG. *5h*, an inflatable volume filling device **10** is placed in its deflated state in the cup like structure. The volume filling device **10** is then inflated to its inflated or expanded state, see FIG. *5i*. This inflation of the volume filling device **10** can be accomplished by injecting a fluid or a gel into the deflated volume filling device. It can also be accomplished by injecting a material which is allowed to cure, thereby forming a solid device **10**. Thus, the volume filling device **10** shown in FIGS. *5h* and *5i* can illustrate either a balloon-like device which is subsequently filled with fluid or gel or alternatively a material which is simply injected into the cup like structure formed by the stomach wall **12a**.

The fluid which is used to fill the volume filling device **10** could be any suitable fluid suitable to fill the inflatable device **10**, such as a salt solution. In another embodiment, when this fluid is a fluid which is adapted to be transformed into solid state, the fluid could be liquid polyurethane.

In order to minimize or entirely eliminate leakage, the fluid is iso-tonic, i.e., it has the same osmolarity as human body fluids. Another way of preventing diffusion is to provide a fluid which comprises large molecules, such as iodine molecules.

The stomach-to-stomach sutures or staples are preferably provided with fixation portions exhibiting a structure, such as a net like structure, adapted to be in contact with the stomach wall to promote growth in of human tissue to secure the long term placement of the volume filling device attached to the stomach wall.

After the inflatable device **10** has been inflated, partly or fully, the inlet port **10h** (not shown in FIGS. *5h* and *5i*) of the volume filling device **10**, is sealed and the instrument **600** is retracted from the hole **12b**, which is subsequently closed in some suitable way, such as by means of the instrument **600**. The instrument is then removed from the stomach **600** and the inflatable device **10** in its inflated or expanded state is invaginated by a stomach wall portion of the patient on the outside of the stomach wall. This reduces the inner volume of the stomach, thereby affecting the patient's appetite.

During one or more of the above described steps, the stomach may be inflated with gas, preferably by means of the gastroscopic instrument.

The volume filling device **10** described above with reference to FIGS. *5a-i* has been described as an inflatable volume filling device. It will be appreciated that it also can be an elastic volume filling device with an elasticity allowing compression so as to be inserted into a gastroscopic instrument and which expands to an expanded state after leaving the instrument.

An alternative embodiment of an apparatus for treating obesity will now be described with reference to FIGS. *6a* and *6b*, showing a sectional view of a stomach in which a volume filling device is invaginated in the stomach wall on the outside thereof together with a system for regulating the size of the volume filling device. The volume filling device is an inflatable device as described above with reference to FIGS. *5a-h* and thus comprises a fluid. The inflatable device **10** thus forms a fluid chamber, in which fluid is allowed to flow. The inflatable device thereby forms an expandable chamber that

can change the volume it occupies in the stomach wall, thereby forming a hydraulically or pneumatically regulated inflatable device.

In FIG. 6a, an injection port 16 for fluids is connected to the inflatable volume filling device 10 by means of a conduit 18 in the form of a tube. The inflatable device 10 is thereby adapted to be regulated, preferably non-invasively, by moving liquid or air from the injection port 16 to the chamber formed by the inflatable device. By using a hypodermic needle or the like, the amount of fluid in the inflatable device 10 can thus be adjusted, thereby adjusting the size of the adjustable device. The injection port 16 can also be used simply for refilling the volume filling device 10.

The regulation reservoir 17 can be regulated in several ways. In an alternative embodiment, the regulation reservoir 17 is regulated by manually pressing a regulation reservoir. In other words, the regulation reservoir is regulated by moving a wall of the reservoir. It is then preferred that the regulation reservoir is placed subcutaneously and non-invasive regulation is thereby achieved.

A similar embodiment is shown in FIG. 6b. However, in this embodiment the injection port 16 has been replaced by an adjustable regulation reservoir 17 in fluid connecting with the volume filling device 10 via a tube 18. When the regulation reservoir 17 is pressed, the volume thereof decreases and hydraulic fluid is moved from the reservoir to the chamber formed by the inflatable device 10 via the conduit or tube 18, enlarging or expanding the inflatable device 10. In this way, the volume filling device is non-invasively adjustable postoperatively.

It will be appreciated that instead of hydraulic operation, pneumatic operation can be used, wherein air instead of hydraulic fluid is moved between the regulation reservoir and the chamber formed by the inflatable device 10. Preferable the regulation reservoir has a locking position to keep it in the desired position. If the patient compresses the reservoir it preferably stays compressed and releases after pressing again.

Any kind of hydraulic solution may be used for the inflatable device. The hydraulic solution may be driven by both mechanically and be powered with any motor or pump as well as manually.

In another embodiment, shown in FIG. 7, a motor 40 is adapted to move a wall of the regulation reservoir 17. The powered regulation reservoir 17 is then preferably placed in the abdomen of the patient. In this embodiment, a wireless external remote control unit forming part of the external energy transmission device 34 can be provided to perform non-invasive regulation of the motor via an energy transforming device 30, which is adapted to supply an energy consuming operation device, in the present example the motor 40, with energy via a power supply line 32.

The remote control may comprise a wireless energy transmitter, whereby the non-invasive regulation is performed by the energy transmitter. When the regulation is performed by means of a remote control an internal power source for powering the regulating device is provided. The internal energy source can for example be a chargeable implanted battery or a capacitor or a device for receiving wireless energy transmitted from outside the body of the patient. Different ways of regulating the inflatable device 10 will be described below with reference to FIGS. 22-41.

In yet an alternative embodiment, shown in FIG. 8, the apparatus for treating obesity comprises a pump 44, wherein the reservoir is regulated by the pump 44 pumping fluid or air from the reservoir to the chamber formed by the inflatable

device. Different configurations of this pump will be described below with reference to FIGS. 22-41.

Yet an alternative embodiment of an apparatus for treating obesity will now be described with reference to FIG. 9, which shows a stomach 12 of a patient who is treated for obesity. This embodiment is similar to the one described above with reference to FIG. 7 and the apparatus comprises a volume filling device in the form of an inflatable device 10 which is invaginated in the wall 12a of the patient's stomach 12. However, in this case the invagination has been performed in the fundus, i.e., the upper portion of the stomach, where the number of receptors in the stomach wall is large, and the inflatable device functions as a stretching device for part of the stomach fundus wall.

A regulation reservoir 17 for fluids is connected to the inflatable device by means of a conduit 18 in the form of a tube. The inflatable device 10 is thereby adapted to be regulated, preferably non-invasively, by moving liquid or air from the regulation reservoir 17 to the chamber formed by the inflatable device 10. The regulation of the inflatable device 10 preferably comprises a reversed servo, i.e., a small volume is actuated for example by the patient's finger and this small volume is in connection with a larger volume, i.e., the regulation reservoir 17.

Thus, the inflatable device 10 is placed outside the stomach wall and is adapted to stretch a part of the stomach fundus wall, thereby affecting the patient's appetite. By enlarging the size of the stretching device, the stomach fundus wall 12a surrounding the inflatable stretching device 10 is stretched since the circumference of the inflatable stretching device 10 is increased. By this stretching, the receptors in the stomach wall indicate that the stomach is full, thereby creating a feeling of satiety to the patient. Correspondingly, when the stretching device 10 is contracted, the receptors indicate that the stomach is not full, thereby returning the feeling of hunger. It will be appreciated that this embodiment combines the effects of both reducing the volume of the stomach food cavity and stretching part of the stomach wall, thereby increasing the treatment effect.

The expansion and contraction of the stretching device 10 can be performed under direct control of the patient. Alternatively, the expansion and contraction can be performed according to a pre-programmed schedule.

In a preferred embodiment, shown in FIG. 10, a sensor 19 is provided at a suitable position, such as at the esophagus. The volume filling device 10 in the form of the inflatable stretching device is similar to the one shown in FIG. 9. By providing one or more sensors, the apparatus for treating obesity can be automated in that the size of the volume filling device 10 in the form of the inflatable stretching device is adjusted depending on the amount of food entering the food cavity of the stomach. The fluid is thereby moved between the inflatable volume filling device 10 and a fluid reservoir 15.

The apparatus for treating obesity can have the additional functionality of treating reflux. An embodiment having this function is shown in FIG. 11, wherein the volume filling device 10 is invaginated in the stomach wall close to and at least partially above the patient's cardia 26 when the patient is in a standing position and is fixed to a position above the cardia area 26 by a fixation, such as sutures or staples 14a. For example a direct or indirect fixation to the diaphragm muscle or associated muscles may be provided. As an alternative a direct or indirect fixation to the esophagus above and close to the angle of His can be provided. In this alternative embodiment, the volume filling device 10 rests in a position against stomach wall of the fundus when implanted and which also fills a volume above the cardia area 26 between the cardia and

the diaphragm muscle so that the cardia is prevented from slipping up into the thorax cavity, whereby reflux disease is prevented.

Such a volume filling device **10** may be used for keeping electronics and/or an energy source and/or hydraulic fluid. Hydraulic fluid from that device may be distributed to several smaller inflatable device areas to vary the stretching area from time to time avoiding any possible more permanent stretching effect of the stomach wall. Even mechanically several stretching areas may be used.

In an alternative embodiment, which is shown in FIG. **12**, the volume of an inflatable volume filling device **10** may be in fluid connection with one or more preferably smaller inflatable devices or chambers **50**. These chambers are adapted to communicate with fluid or air being moved between the chambers.

Thus, the large chamber **10** is adapted to, with its main volume to be a volume filling device for reducing the size of the food cavity and for treating reflux disease and the one or several small chambers are adapted to function as the inflatable devices to treat obesity, wherein the main chamber is adapted to communicate with fluid or air to the small chambers causing a stretching effect in the stomach wall thereby further treating obesity.

In FIGS. **13-16**, different embodiments embodying a combination of a volume filling device invaginated in the central or lower portion of the stomach and a stretching device invaginated in the upper portion or fundus of the patient's stomach. Thus, in FIG. **13** there is shown an adjustable volume filling device **10**, which is invaginated in the stomach wall of a patient's stomach **12**. Additionally, an adjustable stretching device **50** with the previously described function is invaginated in the stomach fundus wall of the patient. It is preferred that the volume filling device **10** is substantially larger than the stretching device **50**.

The volume filling device **10** and the stretching device **50** are in fluid communication with each other via a fluid communication device comprising a first fluid tube **52**, in which a pump **54** is provided. The pump **54** is under the control from an energy transforming device **30**, which is adapted to supply the pump **50** with energy via a power supply line **56**. The energy transforming device **30** is also connected to a sensor **19** provided in the esophagus of the patient so that food intake can be detected.

The volume filling device **10** and the stretching device **50** are also in fluid communication with each other via a second fluid tube **58**, which preferably has a smaller cross-sectional area than the first fluid tube **52**.

The operation of this arrangement is as follows. The volume filling device **10** functions as in the above described embodiments, i.e., it reduces the size of the food cavity of the patient's stomach **12**. Additionally, when the stretching device **50** is enlarged by pumping fluid from the volume filling device **10** and to the stretching device **50** by means of the pump **54**, the stomach fundus wall is stretched, creating a feeling of satiety for the patient. Thus, for example when food intake is detected by means of the sensor **19**, fluid is automatically pumped into the stretching device **50** to increase the feeling of satiety and thereby limit the food intake.

When fluid has been injected into the stretching device **50**, the internal pressure therein is higher than the internal pressure in the volume filling device **10**. This difference in pressure will create a flow of fluid in the second, preferably narrower tube **58** from the stretching device **50** to the volume filling device **10**. The flow rate will be determined by among other things the difference in pressure and the cross-sectional area of the second tube **58**. It is preferred that the second tube

is so dimensioned, that the pressures in the volume filling device **10** and the stretching device **50** will return to equilibrium after **3** hours after fluid has been injected into the stretching device **50** to create the feeling of satiety.

In this embodiment, the function of the second tube **58** is to allow fluid to return from the stretching device **50** to the volume filling device **10**. It will be appreciated that this function also can be performed by the pump **54** in the first tube **52** and that the second tube **58** then can be omitted.

FIG. **14** illustrates an embodiment similar to the one illustrated in FIG. **13**. Thus, there is provided an adjustable volume filling device **10**, which is invaginated in the stomach wall of a patient's stomach **12**. Additionally, an adjustable stretching device **50** with the previously described function is invaginated in the stomach fundus wall of the patient. It is preferred that the volume filling device **10** is substantially larger than the stretching device **50**.

The volume filling device **10** and the stretching device **50** are in fluid communication with each other via a first fluid tube **52**, and a second fluid tube, which preferably has a smaller cross-sectional area than the first tube. However, instead of a pump, there is provided a non-return valve **60** in the first fluid tube **52** instead of an energized pump. This non-return valve **60** allows fluid to flow in the direction from the volume filling device **10** and to the stretching device **10** but not vice versa. This means that this embodiment may be entirely non-energized. Instead, it operates according to the following principles.

When the food cavity of the stomach **12** is essentially empty, there is a state of equilibrium between the internal pressure of the volume filling device **10** and the stretching device **50**. In this state, the stretching device is in a non-stretch state, i.e., it does not stretch a part of the stomach fundus wall and thus does not create a feeling of satiety.

When the patient starts to eat, food will enter the food cavity of the stomach **12**. This will create increased pressure on the stomach wall in which the volume filling device **10** is invaginated and the internal pressure therein will increase. Also, the stomach wall muscles will begin to process the food in the food cavity by contraction, which also contributes to an increased internal pressure in the volume filling device **10**.

Since the internal pressure in the stretching device **50** will remain essentially unchanged, because it is located in the upper part of the stomach **12** where no food is exerting a pressure on the stomach wall, a fluid flow will be created through the first and second fluid tubes **52, 58** in the direction from the volume filling device **10** and to the stretching device **50**. This in turn will increase the volume of the stretching device **50**, which, by stretching the stomach fundus wall, will provide a feeling of satiety to the patient.

A fluid flow from the stretching device **50** to the volume filling device **10** through the second tube **58** will return the pressure of these devices to equilibrium as described above with reference to FIG. **13**.

FIG. **15** illustrates an embodiment, which is similar to the one shown in FIG. **14** but with the addition of an injection port **16**, which is used for refilling the fluid system comprising the volume filling device **10** and the stretching device **50** or alternatively for actively adjusting the size thereof.

Similarly, FIG. **16** illustrates an embodiment wherein the stretching device **50** can be actively regulated by manually pressing an adjustment reservoir which is provided subcutaneously below the patient's skin, similar to the embodiment shown in FIG. **9**. Thus, a regulation reservoir **17** for fluids is connected to the inflatable device by means of a conduit **18** in the form of a tube. The stretching device **50** is thereby adapted to be regulated, non-invasively, by moving liquid or air from

the regulation reservoir 17 to the chamber formed by the inflatable device. The regulation of the stretching device 50 preferably comprises a reversed servo, i.e., a small volume is actuated for example by the patient's finger and this small volume is in connection with a larger volume.

An alternative placement of the volume filling device 10 is shown in FIGS. 17a and 17b, wherein FIG. 17b shows a sectional view through the stomach shown in FIG. 17a along the line XVIIb-XVIIb. There, the volume filling device 10 is adapted to be placed inside the wall of the stomach 12, such as via a gastroscope or similar intraluminal instrument, and resting against the inside of the stomach wall 12a. The inflatable device can be kept invaginated by means of sutures or staples 14, like in the embodiment of FIGS. 2a and 2b. In this embodiment, no hole is required in the stomach wall. Instead, a method of providing the volume filling device 10 can comprise the following steps, which will be explained with reference to FIGS. 18a-h showing an invagination instrument

The invagination instrument, generally designated 630, comprises an elongated tube member 632 similar to the elongated member 607 described above with reference to FIGS. 5a-i. Thus, it can be connected to a control unit 606, see FIG. 5a. The invagination instrument 630 further comprises a perforated suction portion 634, which preferably is elongated. The suction portion 634 exhibits a plurality of small holes 636, into which air will be sucked by providing suction in the tube member 632. This suction effect will be used to create a "pocket" or "pouch" in a part of a stomach wall, generally designated 12a.

In other words, when the tip of the suction portion 634 is pressed against the stomach wall 12a, see FIG. 18a, a small recess will be formed therein. When the suction portion 634 is further pressed against the stomach wall 12a, see FIG. 18b, a larger recess will be formed. The part of the stomach wall 12a that forms the recess will, due to the suction effect, adhere to the suction portion 634 of the invagination instrument 630. As the suction portion 634 is further pressed into the stomach wall 12a, see FIG. 18c, a deeper recess will be formed until the entire suction portion 634 is embedded in the recess, see FIG. 18d.

The rim of the recess will at this stage be fixated by means of fixation elements 638 and the suction portion be removed from the instrument, see FIG. 18e. A compressed elastic volume filling device 10 will subsequently be inserted into the recess, see FIG. 18f, for example in the way described above with reference to FIG. 4d. This compressed volume filling device is then expanded to its final shape, see FIG. 18g, where after the pouch is sealed by suturing or stapling by means of the fixations elements, see FIG. 18h.

All the alternatives described above with reference to FIGS. 2-16 are also applicable to the embodiment described with reference to FIGS. 17 and 18, i.e., to the embodiment where the volume filling device is invaginated on the inside of the stomach wall.

FIGS. 19a-j show an instrument for use in a method of engaging a volume filling device 10 to the stomach wall 12 of a patient. The instrument is adapted to be inserted through a narrow tube shaped object such as a gastroscope, used in an intraluminal procedure, or a laparoscopic trocar used in a laparoscopic procedure. The instrument comprises an elongated member 650 which is adapted to be flexible by means of a construction comprising multiple ring shaped members, however it is equally conceivable that said elongated member 650 is adapted to be flexible by means of said elongated member 650 being made of a flexible or adjustable material. The elongated member 650 is inserted into the body and placed in proximity to the stomach wall 12 of the patient, from

the outside or inside thereof. The elongated member 650 has a special holding device 651 adapted to hold the stomach by means of mechanical grabbing members or vacuum. The special holding device 651 comprises a first joint 652 and a second joint 653, which enable the special holding device 651 to be operable in relation to the elongated member 650 and thereby place the part of the holding device 651 comprising the mechanical grabbing members or vacuum elements into contact with the stomach wall 12 of the patient. FIG. 19b shows the special holding device 651 when placed in contact with the stomach wall 12 of the human patient, after which the special holding member 651 connects to the stomach wall 12, for holding the stomach wall 12. FIG. 19c shows the instrument when the step of advancing a pushing rod 654 from the elongated member 650 is performed. The pushing rod 654 pushes the stomach wall 12 to create a cavity or pouch thereof. FIG. 19d shows the instrument turned 90° in relation to FIGS. 19a-c. This view shows the special holding members 651a,b operably attached to two sides of the elongated member 650 and being in contact with the stomach wall 12, holding the stomach wall 12 as the pushing rod 654 pushes to create a cavity or pouch. When the pushing rod 654 has pushed the stomach wall 12 to a desired position the special holding devices 651a,b moves towards the pushing rod 654 and thereby closes the cavity or pouch.

After the cavity or pouch has been created it needs to be sealed. FIG. 19f shows the advancement of a suturing or stapling device 655 from the elongated member 650. The suturing or stapling device 655 is positioned in connection with the stomach wall after which the suturing or stapling device commences with the suturing or stapling of the stomach wall 12, creating a seal of stomach to stomach sutures or staples 14. The instrument is moved along the stomach wall 12 of the patient and thereby a cavity or pouch is created and sealed using the instrument, as shown in FIGS. 19g and 19h. When a cavity or pouch of desired size has been created and sealed an inserting member 656 is advanced from the elongated member 650. The inserting member 656 is adapted to insert a volume filling device 10 being inflatable, as described earlier in this application. After the inserting member 656 has been positioned in the cavity or pouch the volume filling device 10 is inserted through the inserting member 656 and into the cavity or pouch by means of a pressurized fluid or gas, or a mechanical advancement member pushing said inflatable volume filling device 10 into the cavity or pouch. The insertion member then inflates the inflatable volume filling device with a fluid or gas and seals of the final section of the pouch using stomach to stomach sutures or staples 14. The embodiment described explains the process of inserting an inflatable volume filling device, however it is equally conceivable that the volume filling device 10 is expandable by means of the volume filling device 10 being made of an elastic material.

FIGS. 20a-f show an instrument for use in a method of engaging a volume filling device 10 to the stomach wall 12 of a patient. The instrument is adapted to be inserted through a narrow tube shaped object such as a gastroscope, used in an intraluminal procedure, or a laparoscopic trocar used in a laparoscopic procedure. The instrument comprises an elongated member 660 which is adapted to be flexible by means of a construction comprising multiple ring shaped members, however it is equally conceivable that said elongated member 660 is adapted to be flexible by means of said elongated member 660 being made of a flexible or adjustable material. The elongated member 660 is inserted into the body and placed in proximity to the stomach wall 12 of the patient, from the outside or inside thereof. The elongated member 660 has multiple special holding devices 661 adapted to hold the

stomach by means of mechanical grabbing members or vacuum. The special holding devices **661** are locked in a position alongside the elongated member **660** by means of a locking ring **662**. The special holding devices are made of a flexible material end pre-bent to expand into a funnel-shaped device when said locking ring **662** is removed. The special holding device in its funnel shaped expandable state is shown in FIG. **20b**. FIG. **20b** further shows the special holding device **661** when placed in contact with the stomach wall **12** of the human patient, after which the special holding member **661** connects to the stomach wall **12**, for holding the stomach wall **12**. FIG. **20c** shows the instrument when the step of advancing a pushing rod **664** from the elongated member **660** is performed. The pushing rod **664** pushes the stomach wall **12** to create a cavity or pouch thereof. When the pushing rod **664** has pushed the stomach wall **12** to a desired position the special holding devices **661** moves towards the pushing rod **664** and thereby closes the cavity or pouch.

After the cavity or pouch has been created it needs to be sealed. FIG. **20d** shows the advancement of a suturing or stapling device **665** from the elongated member **660**. The suturing or stapling device **665** is positioned in connection with the stomach wall **12** after which the suturing or stapling device **665** commences with the suturing or stapling of the stomach wall **12**, creating a seal of stomach to stomach sutures or staples **14**. Thereafter an inserting member **656** is advanced from the elongated member **660** and the special holding devices **661** are retracted. The inserting member **656** is adapted to insert a volume filling device **10** being inflatable, as described earlier in this application. After the inserting member **656** has been positioned in the cavity or pouch the volume filling device **10** is inserted through the inserting member **656** and into the cavity or pouch by means of a pressurized fluid or gas, or a mechanical advancement member pushing said inflatable volume filling device **10** into the cavity or pouch. The insertion member **656** then inflates the inflatable volume filling device with a fluid or gas and seals the final section of the pouch using stomach to stomach sutures or staples **14**. The embodiment described explains the process of inserting an inflatable volume filling device **10**, however it is equally conceivable that the volume filling device **10** is expandable by means of the volume filling device **10** being made of an elastic material. FIG. **20f** shows the volume filling device **10** as the volume filling device **10** is invaginated in the stomach wall **12**, in a cavity or pouch sealed with stomach to stomach sutures or staples **14**.

FIG. **21a** shows an instrument used in a method of engaging the volume filling device according to any of the embodiments of the application to the stomach wall **12**. The instrument comprises an elongated member **670** which is adapted to be flexible by means of a construction comprising multiple ring shaped members, however it is equally conceivable that said elongated member **670** is adapted to be flexible by means of said elongated member **670** being made of a flexible or adjustable material.

The elongated member **670** is inserted into the body and placed in proximity to the stomach wall **12** of the patient, from the inside thereof. A stomach penetrating member **672** is placed in the distal end of the elongated member **670**, retractably fixated to a protective sleeve **673** adapted to protect the tissue of the body from the sharp penetrating member **672** or cutter **672** after the cutting operation has been performed.

FIG. **21b** shows the instrument comprising the elongated member **670** after the cutting operation has been performed and the stomach penetrating member or cutter **672** has been retracted into the protective sleeve **673**. A guiding wire **671** is pushed through the elongated member **670**, through the hole

made in the stomach wall **12** and out through the abdomen and placed on the inside of the patients skin, which is penetrated from the outside to enable the guiding wire **671** to exit the abdomen. The guiding wire **671** can then be used to guide a conduit **18** or a lead attached to the volume filling device **10** being placed in the stomach from the inside thereof. The volume filling device **10** with the conduit **18** or electrical lead being a volume filling device **10** according to any of the embodiments of this application. The guiding of the conduit **18** or electrical lead enables the attachment of the conduit **18** or electrical lead to a control unit **42** placed subcutaneously in the patient from the outside of the abdomen.

FIG. **22** illustrates a system for treating a disease comprising an apparatus **10** comprising a volume filling device of the present invention placed in the abdomen of a patient. An implanted energy-transforming device **1002** is adapted to supply energy consuming components of the apparatus with energy via a power supply line **1003**. An external energy-transmission device **1004** for non-invasively energizing the apparatus **10** transmits energy by at least one wireless energy signal. The implanted energy-transforming device **1002** transforms energy from the wireless energy signal into electric energy which is supplied via the power supply line **1003**.

The implanted energy-transforming device **1002** may also comprise other components, such as: a coil for reception and/or transmission of signals and energy, an antenna for reception and/or transmission of signals, a microcontroller, a charge control unit, optionally comprising an energy storage, such as a capacitor, one or more sensors, such as temperature sensor, pressure sensor, position sensor, motion sensor etc., a transceiver, a motor, optionally including a motor controller, a pump, and other parts for controlling the operation of a medical implant.

The wireless energy signal may include a wave signal selected from the following: a sound wave signal, an ultrasound wave signal, an electromagnetic wave signal, an infrared light signal, a visible light signal, an ultra violet light signal, a laser light signal, a micro wave signal, a radio wave signal, an x-ray radiation signal and a gamma radiation signal. Alternatively, the wireless energy signal may include an electric or magnetic field, or a combined electric and magnetic field.

The wireless energy-transmission device **1004** may transmit a carrier signal for carrying the wireless energy signal. Such a carrier signal may include digital, analogue or a combination of digital and analogue signals. In this case, the wireless energy signal includes an analogue or a digital signal, or a combination of an analogue and digital signal.

Generally speaking, the energy-transforming device **1002** is provided for transforming wireless energy of a first form transmitted by the energy-transmission device **1004** into energy of a second form, which typically is different from the energy of the first form. The implanted apparatus **10** is operable in response to the energy of the second form. The energy-transforming device **1002** may directly power the apparatus with the second form energy, as the energy-transforming device **1002** transforms the first form energy transmitted by the energy-transmission device **1004** into the second form energy. The system may further include an implantable accumulator, wherein the second form energy is used at least partly to charge the accumulator.

Alternatively, the wireless energy transmitted by the energy-transmission device **1004** may be used to directly power the apparatus, as the wireless energy is being transmitted by the energy-transmission device **1004**. Where the system comprises an operation device for operating the apparatus, as will be described below, the wireless energy

transmitted by the energy-transmission device **1004** may be used to directly power the operation device to create kinetic energy for the operation of the apparatus.

The wireless energy of the first form may comprise sound waves and the energy-transforming device **1002** may include a piezo-electric element for transforming the sound waves into electric energy. The energy of the second form may comprise electric energy in the form of a direct current or pulsating direct current, or a combination of a direct current and pulsating direct current, or an alternating current or a combination of a direct and alternating current. Normally, the apparatus comprises electric components that are energized with electrical energy. Other implantable electric components of the system may be at least one voltage level guard or at least one constant current guard connected with the electric components of the apparatus.

Optionally, one of the energy of the first form and the energy of the second form may comprise magnetic energy, kinetic energy, sound energy, chemical energy, radiant energy, electromagnetic energy, photo energy, nuclear energy or thermal energy. Preferably, one of the energy of the first form and the energy of the second form is non-magnetic, non-kinetic, non-chemical, non-sonic, non-nuclear or non-thermal.

The energy-transmission device may be controlled from outside the patient's body to release electromagnetic wireless energy, and the released electromagnetic wireless energy is used for operating the apparatus. Alternatively, the energy-transmission device is controlled from outside the patient's body to release non-magnetic wireless energy, and the released non-magnetic wireless energy is used for operating the apparatus.

The external energy-transmission device **1004** also includes a wireless remote control having an external signal transmitter for transmitting a wireless control signal for non-invasively controlling the apparatus. The control signal is received by an implanted signal receiver which may be incorporated in the implanted energy-transforming device **1002** or be separate there from.

The wireless control signal may include a frequency, amplitude, or phase modulated signal or a combination thereof. Alternatively, the wireless control signal includes an analogue or a digital signal, or a combination of an analogue and digital signal. Alternatively, the wireless control signal comprises an electric or magnetic field, or a combined electric and magnetic field.

The wireless remote control may transmit a carrier signal for carrying the wireless control signal. Such a carrier signal may include digital, analogue or a combination of digital and analogue signals. Where the control signal includes an analogue or a digital signal, or a combination of an analogue and digital signal, the wireless remote control preferably transmits an electromagnetic carrier wave signal for carrying the digital or analogue control signals.

FIG. **23** illustrates the system of FIG. **22** in the form of a more generalized block diagram showing the apparatus **10**, the energy-transforming device **1002** powering the apparatus **10** via power supply line **1003**, and the external energy-transmission device **1004**. The patient's skin **1005**, generally shown by a vertical line, separates the interior of the patient to the right of the line from the exterior to the left of the line.

FIG. **24** shows an embodiment of the invention identical to that of FIG. **23**, except that a reversing device in the form of an electric switch **1006** operable for example by polarized energy also is implanted in the patient for reversing the apparatus **10**. When the switch is operated by polarized energy the wireless remote control of the external energy-transmission

device **1004** transmits a wireless signal that carries polarized energy and the implanted energy-transforming device **1002** transforms the wireless polarized energy into a polarized current for operating the electric switch **1006**. When the polarity of the current is shifted by the implanted energy-transforming device **1002** the electric switch **1006** reverses the function performed by the apparatus **10**.

FIG. **25** shows an embodiment of the invention identical to that of FIG. **23**, except that an operation device **1007** implanted in the patient for operating the apparatus **10** is provided between the implanted energy-transforming device **1002** and the apparatus **10**. This operation device can be in the form of a motor **1007**, such as an electric servomotor. The motor **1007** is powered with energy from the implanted energy-transforming device **1002**, as the remote control of the external energy-transmission device **1004** transmits a wireless signal to the receiver of the implanted energy-transforming device **1002**.

FIG. **26** shows an embodiment of the invention identical to that of FIG. **23**, except that it also comprises an operation device is in the form of an assembly **1008** including a motor/pump unit **1009** and a fluid reservoir **1010** is implanted in the patient. In this case the apparatus **10** is hydraulically operated, i.e. hydraulic fluid is pumped by the motor/pump unit **1009** from the fluid reservoir **1010** through a conduit **1011** to the apparatus **10** to operate the apparatus, and hydraulic fluid is pumped by the motor/pump unit **1009** back from the apparatus **10** to the fluid reservoir **1010** to return the apparatus to a starting position. The implanted energy-transforming device **1002** transforms wireless energy into a current, for example a polarized current, for powering the motor/pump unit **1009** via an electric power supply line **1012**.

Instead of a hydraulically operated apparatus **10**, it is also envisaged that the operation device comprises a pneumatic operation device. In this case, the hydraulic fluid can be pressurized air to be used for regulation and the fluid reservoir is replaced by an air chamber.

In all of these embodiments the energy-transforming device **1002** may include a rechargeable accumulator like a battery or a capacitor to be charged by the wireless energy and supplies energy for any energy consuming part of the system.

As an alternative, the wireless remote control described above may be replaced by manual control of any implanted part to make contact with by the patient's hand most likely indirect, for example a press button placed under the skin.

FIG. **27** shows an embodiment of the invention comprising the external energy-transmission device **1004** with its wireless remote control, the apparatus **10**, in this case hydraulically operated, and the implanted energy-transforming device **1002**, and further comprising a hydraulic fluid reservoir **1013**, a motor/pump unit **1009** and an reversing device in the form of a hydraulic valve shifting device **1014**, all implanted in the patient. Of course the hydraulic operation could easily be performed by just changing the pumping direction and the hydraulic valve may therefore be omitted. The remote control may be a device separated from the external energy-transmission device or included in the same. The motor of the motor/pump unit **1009** is an electric motor. In response to a control signal from the wireless remote control of the external energy-transmission device **1004**, the implanted energy-transforming device **1002** powers the motor/pump unit **1009** with energy from the energy carried by the control signal, whereby the motor/pump unit **1009** distributes hydraulic fluid between the hydraulic fluid reservoir **1013** and the apparatus **10**. The remote control of the external energy-transmission device **1004** controls the hydraulic valve shifting device **1014** to shift the hydraulic fluid flow direction between one direc-

tion in which the fluid is pumped by the motor/pump unit **1009** from the hydraulic fluid reservoir **1013** to the apparatus **10** to operate the apparatus, and another opposite direction in which the fluid is pumped by the motor/pump unit **1009** back from the apparatus **10** to the hydraulic fluid reservoir **1013** to return the apparatus to a starting position.

FIG. **28** shows an embodiment of the invention comprising the external energy-transmission device **1004** with its wireless remote control, the apparatus **10**, the implanted energy-transforming device **1002**, an implanted internal control unit **1015** controlled by the wireless remote control of the external energy-transmission device **1004**, an implanted accumulator **1016** and an implanted capacitor **1017**. The internal control unit **1015** arranges storage of electric energy received from the implanted energy-transforming device **1002** in the accumulator **1016**, which supplies energy to the apparatus **10**. In response to a control signal from the wireless remote control of the external energy-transmission device **1004**, the internal control unit **1015** either releases electric energy from the accumulator **1016** and transfers the released energy via power lines **1018** and **1019**, or directly transfers electric energy from the implanted energy-transforming device **1002** via a power line **1020**, the capacitor **1017**, which stabilizes the electric current, a power line **1021** and the power line **1019**, for the operation of the apparatus **10**.

The internal control unit is preferably programmable from outside the patient's body. In a preferred embodiment, the internal control unit is programmed to regulate the apparatus **10** according to a pre-programmed time-schedule or to input from any sensor sensing any possible physical parameter of the patient or any functional parameter of the system.

In accordance with an alternative, the capacitor **1017** in the embodiment of FIG. **28** may be omitted. In accordance with another alternative, the accumulator **1016** in this embodiment may be omitted.

FIG. **29** shows an embodiment of the invention identical to that of FIG. **23**, except that a battery **1022** for supplying energy for the operation of the apparatus **10** and an electric switch **1023** for switching the operation of the apparatus **10** also are implanted in the patient. The electric switch **1023** may be controlled by the remote control and may also be operated by the energy supplied by the implanted energy-transforming device **1002** to switch from an off mode, in which the battery **1022** is not in use, to an on mode, in which the battery **1022** supplies energy for the operation of the apparatus **10**.

FIG. **30** shows an embodiment of the invention identical to that of FIG. **29**, except that an internal control unit **1015** controllable by the wireless remote control of the external energy-transmission device **1004** also is implanted in the patient. In this case, the electric switch **1023** is operated by the energy supplied by the implanted energy-transforming device **1002** to switch from an off mode, in which the wireless remote control is prevented from controlling the internal control unit **1015** and the battery is not in use, to a standby mode, in which the remote control is permitted to control the internal control unit **1015** to release electric energy from the battery **1022** for the operation of the apparatus **10**.

FIG. **31** shows an embodiment of the invention identical to that of FIG. **30**, except that an accumulator **1016** is substituted for the battery **1022** and the implanted components are interconnected differently. In this case, the accumulator **1016** stores energy from the implanted energy-transforming device **1002**. In response to a control signal from the wireless remote control of the external energy-transmission device **1004**, the internal control unit **1015** controls the electric switch **1023** to switch from an off mode, in which the accumulator **1016** is

not in use, to an on mode, in which the accumulator **1016** supplies energy for the operation of the apparatus **10**. The accumulator may be combined with or replaced by a capacitor.

FIG. **32** shows an embodiment of the invention identical to that of FIG. **31**, except that a battery **1022** also is implanted in the patient and the implanted components are interconnected differently. In response to a control signal from the wireless remote control of the external energy-transmission device **1004**, the internal control unit **1015** controls the accumulator **1016** to deliver energy for operating the electric switch **1023** to switch from an off mode, in which the battery **1022** is not in use, to an on mode, in which the battery **1022** supplies electric energy for the operation of the apparatus **10**.

Alternatively, the electric switch **1023** may be operated by energy supplied by the accumulator **1016** to switch from an off mode, in which the wireless remote control is prevented from controlling the battery **1022** to supply electric energy and is not in use, to a standby mode, in which the wireless remote control is permitted to control the battery **1022** to supply electric energy for the operation of the apparatus **10**.

It should be understood that the switch **1023** and all other switches in this application should be interpreted in its broadest embodiment. This means a transistor, MCU, MCP, ASIC, FPGA or a DA converter or any other electronic component or circuit that may switch the power on and off. Preferably the switch is controlled from outside the body, or alternatively by an implanted internal control unit.

FIG. **33** shows an embodiment of the invention identical to that of FIG. **29**, except that a motor **1007**, a mechanical reversing device in the form of a gear box **1024**, and an internal control unit **1015** for controlling the gear box **1024** also are implanted in the patient. The internal control unit **1015** controls the gear box **1024** to reverse the function performed by the apparatus **10** (mechanically operated). Even simpler is to switch the direction of the motor electronically. The gear box interpreted in its broadest embodiment may stand for a servo arrangement saving force for the operation device in favour of longer stroke to act.

FIG. **34** shows an embodiment of the invention identical to that of FIG. **40** except that the implanted components are interconnected differently. Thus, in this case the internal control unit **1015** is powered by the battery **1022** when the accumulator **1016**, suitably a capacitor, activates the electric switch **1023** to switch to an on mode. When the electric switch **1023** is in its on mode the internal control unit **1015** is permitted to control the battery **1022** to supply, or not supply, energy for the operation of the apparatus **10**.

FIG. **35** schematically shows conceivable combinations of implanted components of the apparatus for achieving various communication options. Basically, there are the apparatus **10**, the internal control unit **1015**, motor or pump unit **1009**, and the external energy-transmission device **1004** including the external wireless remote control. As already described above the wireless remote control transmits a control signal which is received by the internal control unit **1015**, which in turn controls the various implanted components of the apparatus.

A feedback device, preferably comprising a sensor or measuring device **1025**, may be implanted in the patient for sensing a physical parameter of the patient. The physical parameter may be at least one selected from the group consisting of pressure, volume, diameter, stretching, elongation, extension, movement, bending, elasticity, muscle contraction, nerve impulse, body temperature, blood pressure, blood flow, heartbeats and breathing. The sensor may sense any of the above physical parameters. For example, the sensor may be a pressure or motility sensor. Alternatively, the sensor **1025** may be

arranged to sense a functional parameter. The functional parameter may be correlated to the transfer of energy for charging an implanted energy source and may further include at least one selected from the group of parameters consisting of; electricity, any electrical parameter, pressure, volume, diameter, stretch, elongation, extension, movement, bending, elasticity, temperature and flow.

The feedback may be sent to the internal control unit or out to an external control unit preferably via the internal control unit. Feedback may be sent out from the body via the energy transfer system or a separate communication system with receiver and transmitters.

The internal control unit **1015**, or alternatively the external wireless remote control of the external energy-transmission device **1004**, may control the apparatus **10** in response to signals from the sensor **1025**. A transceiver may be combined with the sensor **1025** for sending information on the sensed physical parameter to the external wireless remote control. The wireless remote control may comprise a signal transmitter or transceiver and the internal control unit **1015** may comprise a signal receiver or transceiver. Alternatively, the wireless remote control may comprise a signal receiver or transceiver and the internal control unit **1015** may comprise a signal transmitter or transceiver. The above transceivers, transmitters and receivers may be used for sending information or data related to the apparatus **10** from inside the patient's body to the outside thereof.

Where the motor/pump unit **1009** and battery **1022** for powering the motor/pump unit **1009** are implanted, information related to the charging of the battery **1022** may be fed back. To be more precise, when charging a battery or accumulator with energy feed back information related to said charging process is sent and the energy supply is changed accordingly.

FIG. **36** shows an alternative embodiment wherein the apparatus **10** is regulated from outside the patient's body. The system **1000** comprises a battery **1022** connected to the apparatus **10** via a subcutaneous electric switch **1026**. Thus, the regulation of the apparatus **10** is performed non-invasively by manually pressing the subcutaneous switch, whereby the operation of the apparatus **10** is switched on and off. It will be appreciated that the shown embodiment is a simplification and that additional components, such as an internal control unit or any other part disclosed in the present application can be added to the system. Two subcutaneous switches may also be used. In the preferred embodiment one implanted switch sends information to the internal control unit to perform a certain predetermined performance and when the patient presses the switch again the performance is reversed.

FIG. **37** shows an alternative embodiment, wherein the system **1000** comprises a hydraulic fluid reservoir **1013** hydraulically connected to the apparatus. Non-invasive regulation is performed by manually pressing the hydraulic reservoir connected to the apparatus. Alternatively, the hydraulic fluid reservoir **1013** is adapted to work with an injection port for the injection of hydraulic fluid, preferably for calibration of hydraulic fluid.

The system may include an external data communicator and an implantable internal data communicator communicating with the external data communicator. The internal communicator feeds data related to the apparatus or the patient to the external data communicator and/or the external data communicator feeds data to the internal data communicator.

FIG. **38** schematically illustrates an arrangement of the system that is capable of sending information from inside the patient's body to the outside thereof to give feedback information related to at least one functional parameter of the

apparatus or system, or related to a physical parameter of the patient, in order to supply an accurate amount of energy to an implanted internal energy receiver **1002** connected to implanted energy consuming components of the apparatus **10**. Such an energy receiver **1002** may include an energy source and/or an energy-transforming device. Briefly described, wireless energy is transmitted from an external energy source **1004a** located outside the patient and is received by the internal energy receiver **1002** located inside the patient. The internal energy receiver is adapted to directly or indirectly supply received energy to the energy consuming components of the apparatus **10** via a switch **1026**. An energy balance is determined between the energy received by the internal energy receiver **1002** and the energy used for the apparatus **10**, and the transmission of wireless energy is then controlled based on the determined energy balance. The energy balance thus provides an accurate indication of the correct amount of energy needed, which is sufficient to operate the apparatus **10** properly, but without causing undue temperature rise.

In FIG. **38** the patient's skin is indicated by a vertical line **1005**. Here, the energy receiver comprises an energy-transforming device **1002** located inside the patient, preferably just beneath the patient's skin **1005**. Generally speaking, the implanted energy-transforming device **1002** may be placed in the abdomen, thorax, muscle fascia (e.g. in the abdominal wall), subcutaneously, or at any other suitable location. The implanted energy-transforming device **1002** is adapted to receive wireless energy E transmitted from the external energy-source **1004a** provided in an external energy-transmission device **1004** located outside the patient's skin **1005** in the vicinity of the implanted energy-transforming device **1002**.

As is well known in the art, the wireless energy E may generally be transferred by means of any suitable Transcutaneous Energy Transfer (TET) device, such as a device including a primary coil arranged in the external energy source **1004a** and an adjacent secondary coil arranged in the implanted energy-transforming device **1002**. When an electric current is fed through the primary coil, energy in the form of a voltage is induced in the secondary coil which can be used to power the implanted energy consuming components of the apparatus, e.g. after storing the incoming energy in an implanted energy source, such as a rechargeable battery or a capacitor. However, the present invention is generally not limited to any particular energy transfer technique, TET devices or energy sources, and any kind of wireless energy may be used.

The amount of energy received by the implanted energy receiver may be compared with the energy used by the implanted components of the apparatus. The term "energy used" is then understood to include also energy stored by implanted components of the apparatus. A control device includes an external control unit **1004b** that controls the external energy source **1004a** based on the determined energy balance to regulate the amount of transferred energy. In order to transfer the correct amount of energy, the energy balance and the required amount of energy is determined by means of a determination device including an implanted internal control unit **1015** connected between the switch **1026** and the apparatus **10**. The internal control unit **1015** may thus be arranged to receive various measurements obtained by suitable sensors or the like, not shown, measuring certain characteristics of the apparatus **10**, somehow reflecting the required amount of energy needed for proper operation of the apparatus **10**. Moreover, the current condition of the patient may also be detected by means of suitable measuring devices

or sensors, in order to provide parameters reflecting the patient's condition. Hence, such characteristics and/or parameters may be related to the current state of the apparatus **10**, such as power consumption, operational mode and temperature, as well as the patient's condition reflected by parameters such as; body temperature, blood pressure, heartbeats and breathing. Other kinds of physical parameters of the patient and functional parameters of the device are described elsewhere.

Furthermore, an energy source in the form of an accumulator **1016** may optionally be connected to the implanted energy-transforming device **1002** via the control unit **1015** for accumulating received energy for later use by the apparatus **10**. Alternatively or additionally, characteristics of such an accumulator, also reflecting the required amount of energy, may be measured as well. The accumulator may be replaced by a rechargeable battery, and the measured characteristics may be related to the current state of the battery, any electrical parameter such as energy consumption voltage, temperature, etc. In order to provide sufficient voltage and current to the apparatus **10**, and also to avoid excessive heating, it is clearly understood that the battery should be charged optimally by receiving a correct amount of energy from the implanted energy-transforming device **1002**, i.e. not too little or too much. The accumulator may also be a capacitor with corresponding characteristics.

For example, battery characteristics may be measured on a regular basis to determine the current state of the battery, which then may be stored as state information in a suitable storage means in the internal control unit **1015**. Thus, whenever new measurements are made, the stored battery state information can be updated accordingly. In this way, the state of the battery can be "calibrated" by transferring a correct amount of energy, so as to maintain the battery in an optimal condition.

Thus, the internal control unit **1015** of the determination device is adapted to determine the energy balance and/or the currently required amount of energy, (either energy per time unit or accumulated energy) based on measurements made by the above-mentioned sensors or measuring devices of the apparatus **10**, or the patient, or an implanted energy source if used, or any combination thereof. The internal control unit **1015** is further connected to an internal signal transmitter **1027**, arranged to transmit a control signal reflecting the determined required amount of energy, to an external signal receiver **1004c** connected to the external control unit **1004b**. The amount of energy transmitted from the external energy source **1004a** may then be regulated in response to the received control signal.

Alternatively, the determination device may include the external control unit **1004b**. In this alternative, sensor measurements can be transmitted directly to the external control unit **1004b** wherein the energy balance and/or the currently required amount of energy can be determined by the external control unit **1004b**, thus integrating the above-described function of the internal control unit **1015** in the external control unit **1004b**. In that case, the internal control unit **1015** can be omitted and the sensor measurements are supplied directly to the internal signal transmitter **1027** which sends the measurements over to the external signal receiver **1004c** and the external control unit **1004b**. The energy balance and the currently required amount of energy can then be determined by the external control unit **1004b** based on those sensor measurements.

Hence, the present solution according to the arrangement of FIG. **38** employs the feed back of information indicating the required energy, which is more efficient than previous

solutions because it is based on the actual use of energy that is compared to the received energy, e.g. with respect to the amount of energy, the energy difference, or the energy receiving rate as compared to the energy rate used by implanted energy consuming components of the apparatus. The apparatus may use the received energy either for consuming or for storing the energy in an implanted energy source or the like. The different parameters discussed above would thus be used if relevant and needed and then as a tool for determining the actual energy balance. However, such parameters may also be needed per se for any actions taken internally to specifically operate the apparatus.

The internal signal transmitter **1027** and the external signal receiver **1004c** may be implemented as separate units using suitable signal transfer means, such as radio, IR (Infrared) or ultrasonic signals. Alternatively, the internal signal transmitter **1027** and the external signal receiver **1004c** may be integrated in the implanted energy-transforming device **1002** and the external energy source **1004a**, respectively, so as to convey control signals in a reverse direction relative to the energy transfer, basically using the same transmission technique. The control signals may be modulated with respect to frequency, phase or amplitude.

Thus, the feedback information may be transferred either by a separate communication system including receivers and transmitters or may be integrated in the energy system. In accordance with the present invention, such an integrated information feedback and energy system comprises an implantable internal energy receiver for receiving wireless energy, the energy receiver having an internal first coil and a first electronic circuit connected to the first coil, and an external energy transmitter for transmitting wireless energy, the energy transmitter having an external second coil and a second electronic circuit connected to the second coil. The external second coil of the energy transmitter transmits wireless energy which is received by the first coil of the energy receiver. This system further comprises a power switch for switching the connection of the internal first coil to the first electronic circuit on and off, such that feedback information related to the charging of the first coil is received by the external energy transmitter in the form of an impedance variation in the load of the external second coil, when the power switch switches the connection of the internal first coil to the first electronic circuit on and off. In implementing this system in the arrangement of FIG. **38**, the switch **1026** is either separate and controlled by the internal control unit **1015**, or integrated in the internal control unit **1015**. It should be understood that the switch **1026** should be interpreted in its broadest embodiment. This means a transistor, MCU, MCPU, ASIC FPGA or a DA converter or any other electronic component or circuit that may switch the power on and off.

To conclude, the energy supply arrangement illustrated in FIG. **38** may operate basically in the following manner. The energy balance is first determined by the internal control unit **1015** of the determination device. A control signal reflecting the required amount of energy is also created by the internal control unit **1015**, and the control signal is transmitted from the internal signal transmitter **1027** to the external signal receiver **1004c**. Alternatively, the energy balance can be determined by the external control unit **1004b** instead depending on the implementation, as mentioned above. In that case, the control signal may carry measurement results from various sensors. The amount of energy emitted from the external energy source **1004a** can then be regulated by the external control unit **1004b**, based on the determined energy balance, e.g. in response to the received control signal. This process may be repeated intermittently at certain intervals

during ongoing energy transfer, or may be executed on a more or less continuous basis during the energy transfer.

The amount of transferred energy can generally be regulated by adjusting various transmission parameters in the external energy source **1004a**, such as voltage, current, amplitude, wave frequency and pulse characteristics.

This system may also be used to obtain information about the coupling factors between the coils in a TET system even to calibrate the system both to find an optimal place for the external coil in relation to the internal coil and to optimize energy transfer. Simply comparing in this case the amount of energy transferred with the amount of energy received. For example if the external coil is moved the coupling factor may vary and correctly displayed movements could cause the external coil to find the optimal place for energy transfer. Preferably, the external coil is adapted to calibrate the amount of transferred energy to achieve the feedback information in the determination device, before the coupling factor is maximized.

This coupling factor information may also be used as a feedback during energy transfer. In such a case, the energy system of the present invention comprises an implantable internal energy receiver for receiving wireless energy, the energy receiver having an internal first coil and a first electronic circuit connected to the first coil, and an external energy transmitter for transmitting wireless energy, the energy transmitter having an external second coil and a second electronic circuit connected to the second coil. The external second coil of the energy transmitter transmits wireless energy which is received by the first coil of the energy receiver. This system further comprises a feedback device for communicating out the amount of energy received in the first coil as a feedback information, and wherein the second electronic circuit includes a determination device for receiving the feedback information and for comparing the amount of transferred energy by the second coil with the feedback information related to the amount of energy received in the first coil to obtain the coupling factor between the first and second coils. The energy transmitter may regulate the transmitted energy in response to the obtained coupling factor.

With reference to FIG. **39**, although wireless transfer of energy for operating the apparatus has been described above to enable non-invasive operation, it will be appreciated that the apparatus can be operated with wire bound energy as well. Such an example is shown in FIG. **39**, wherein an external switch **1026** is interconnected between the external energy source **1004a** and an operation device, such as an electric motor **1007** operating the apparatus **10**. An external control unit **1004b** controls the operation of the external switch **1026** to effect proper operation of the apparatus **10**.

FIG. **40** illustrates different embodiments for how received energy can be supplied to and used by the apparatus **10**. Similar to the example of FIG. **38**, an internal energy receiver **1002** receives wireless energy *E* from an external energy source **1004a** which is controlled by a transmission control unit **1004b**. The internal energy receiver **1002** may comprise a constant voltage circuit, indicated as a dashed box "constant *V*" in the figure, for supplying energy at constant voltage to the apparatus **10**. The internal energy receiver **1002** may further comprise a constant current circuit, indicated as a dashed box "constant *C*" in the figure, for supplying energy at constant current to the apparatus **10**.

The apparatus **10** comprises an energy consuming part **10a**, which may be a motor, pump, restriction device, or any other medical appliance that requires energy for its electrical operation. The apparatus **10** may further comprise an energy storage device **10b** for storing energy supplied from the internal

energy receiver **1002**. Thus, the supplied energy may be directly consumed by the energy consuming part **10a**, or stored by the energy storage device **10b**, or the supplied energy may be partly consumed and partly stored. The apparatus **10** may further comprise an energy stabilizing unit **10c** for stabilizing the energy supplied from the internal energy receiver **1002**. Thus, the energy may be supplied in a fluctuating manner such that it may be necessary to stabilize the energy before consumed or stored.

The energy supplied from the internal energy receiver **1002** may further be accumulated and/or stabilized by a separate energy stabilizing unit **1028** located outside the apparatus **10**, before being consumed and/or stored by the apparatus **10**. Alternatively, the energy stabilizing unit **1028** may be integrated in the internal energy receiver **1002**. In either case, the energy stabilizing unit **1028** may comprise a constant voltage circuit and/or a constant current circuit.

It should be noted that FIG. **38** and FIG. **40** illustrate some possible but non-limiting implementation options regarding how the various shown functional components and elements can be arranged and connected to each other. However, the skilled person will readily appreciate that many variations and modifications can be made within the scope of the present invention.

FIG. **41** schematically shows an energy balance measuring circuit of one of the proposed designs of the system for controlling transmission of wireless energy, or energy balance control system. The circuit has an output signal centered on 2.5V and proportionally related to the energy imbalance. The derivative of this signal shows if the value goes up and down and how fast such a change takes place. If the amount of received energy is lower than the energy used by implanted components of the apparatus, more energy is transferred and thus charged into the energy source. The output signal from the circuit is typically feed to an A/D converter and converted into a digital format. The digital information can then be sent to the external energy-transmission device allowing it to adjust the level of the transmitted energy. Another possibility is to have a completely analog system that uses comparators comparing the energy balance level with certain maximum and minimum thresholds sending information to external energy-transmission device if the balance drifts out of the max/min window.

The schematic FIG. **41** shows a circuit implementation for a system that transfers energy to the implanted energy components of the apparatus of the present invention from outside of the patient's body using inductive energy transfer. An inductive energy transfer system typically uses an external transmitting coil and an internal receiving coil. The receiving coil, **L1**, is included in the schematic FIG. **24**; the transmitting parts of the system are excluded.

The implementation of the general concept of energy balance and the way the information is transmitted to the external energy transmitter can of course be implemented in numerous different ways. The schematic FIG. **41** and the above described method of evaluating and transmitting the information should only be regarded as examples of how to implement the control system.

Circuit Details

In FIG. **41** the symbols **Y1**, **Y2**, **Y3** and so on symbolize test points within the circuit. The components in the diagram and their respective values are values that work in this particular implementation which of course is only one of an infinite number of possible design solutions.

Energy to power the circuit is received by the energy receiving coil **L1**. Energy to implanted components is trans-

mitted in this particular case at a frequency of 25 kHz. The energy balance output signal is present at test point Y1.

Those skilled in the art will realize that the above various embodiments of the system could be combined in many different ways. For example, the electric switch **1006** of FIG. **24** could be incorporated in any of the embodiments of FIGS. **27-33**, the hydraulic valve shifting device **1014** of FIG. **27** could be incorporated in the embodiment of FIG. **26**, and the gear box **1024** could be incorporated in the embodiment of FIG. **25**. Please observe that the switch simply could mean any electronic circuit or component.

The embodiments described in connection with FIGS. **38**, **40** and **41** identify a method and a system for controlling transmission of wireless energy to implanted energy consuming components of an electrically operable apparatus. Such a method and system will be defined in general terms in the following.

A method is thus provided for controlling transmission of wireless energy supplied to implanted energy consuming components of an apparatus as described above. The wireless energy E is transmitted from an external energy source located outside the patient and is received by an internal energy receiver located inside the patient, the internal energy receiver being connected to the implanted energy consuming components of the apparatus for directly or indirectly supplying received energy thereto. An energy balance is determined between the energy received by the internal energy receiver and the energy used for the apparatus. The transmission of wireless energy E from the external energy source is then controlled based on the determined energy balance.

The wireless energy may be transmitted inductively from a primary coil in the external energy source to a secondary coil in the internal energy receiver. A change in the energy balance may be detected to control the transmission of wireless energy based on the detected energy balance change. A difference may also be detected between energy received by the internal energy receiver and energy used for the medical device, to control the transmission of wireless energy based on the detected energy difference.

When controlling the energy transmission, the amount of transmitted wireless energy may be decreased if the detected energy balance change implies that the energy balance is increasing, or vice versa. The decrease/increase of energy transmission may further correspond to a detected change rate.

The amount of transmitted wireless energy may further be decreased if the detected energy difference implies that the received energy is greater than the used energy, or vice versa. The decrease/increase of energy transmission may then correspond to the magnitude of the detected energy difference.

As mentioned above, the energy used for the medical device may be consumed to operate the medical device, and/or stored in at least one energy storage device of the medical device.

When electrical and/or physical parameters of the medical device and/or physical parameters of the patient are determined, the energy may be transmitted for consumption and storage according to a transmission rate per time unit which is determined based on said parameters. The total amount of transmitted energy may also be determined based on said parameters.

When a difference is detected between the total amount of energy received by the internal energy receiver and the total amount of consumed and/or stored energy, and the detected difference is related to the integral over time of at least one measured electrical parameter related to said energy balance,

the integral may be determined for a monitored voltage and/or current related to the energy balance.

When the derivative is determined over time of a measured electrical parameter related to the amount of consumed and/or stored energy, the derivative may be determined for a monitored voltage and/or current related to the energy balance.

The transmission of wireless energy from the external energy source may be controlled by applying to the external energy source electrical pulses from a first electric circuit to transmit the wireless energy, the electrical pulses having leading and trailing edges, varying the lengths of first time intervals between successive leading and trailing edges of the electrical pulses and/or the lengths of second time intervals between successive trailing and leading edges of the electrical pulses, and transmitting wireless energy, the transmitted energy generated from the electrical pulses having a varied power, the varying of the power depending on the lengths of the first and/or second time intervals.

In that case, the frequency of the electrical pulses may be substantially constant when varying the first and/or second time intervals. When applying electrical pulses, the electrical pulses may remain unchanged, except for varying the first and/or second time intervals. The amplitude of the electrical pulses may be substantially constant when varying the first and/or second time intervals. Further, the electrical pulses may be varied by only varying the lengths of first time intervals between successive leading and trailing edges of the electrical pulses.

A train of two or more electrical pulses may be supplied in a row, wherein when applying the train of pulses, the train having a first electrical pulse at the start of the pulse train and having a second electrical pulse at the end of the pulse train, two or more pulse trains may be supplied in a row, wherein the lengths of the second time intervals between successive trailing edge of the second electrical pulse in a first pulse train and leading edge of the first electrical pulse of a second pulse train are varied.

When applying the electrical pulses, the electrical pulses may have a substantially constant current and a substantially constant voltage. The electrical pulses may also have a substantially constant current and a substantially constant voltage. Further, the electrical pulses may also have a substantially constant frequency. The electrical pulses within a pulse train may likewise have a substantially constant frequency.

The circuit formed by the first electric circuit and the external energy source may have a first characteristic time period or first time constant, and when effectively varying the transmitted energy, such frequency time period may be in the range of the first characteristic time period or time constant or shorter.

A system comprising an apparatus as described above is thus also provided for controlling transmission of wireless energy supplied to implanted energy consuming components of the apparatus. In its broadest sense, the system comprises a control device for controlling the transmission of wireless energy from an energy-transmission device, and an implantable internal energy receiver for receiving the transmitted wireless energy, the internal energy receiver being connected to implantable energy consuming components of the apparatus for directly or indirectly supplying received energy thereto. The system further comprises a determination device adapted to determine an energy balance between the energy received by the internal energy receiver and the energy used for the implantable energy consuming components of the apparatus, wherein the control device controls the transmis-

sion of wireless energy from the external energy-transmission device, based on the energy balance determined by the determination device.

In one embodiment at least one battery may be a part of or replace the energy-transforming device **1002** to supply energy to the apparatus **10** over a power supply line. In one embodiment the battery is not rechargeable. In an alternative embodiment the battery is rechargeable. The battery supply may of course be placed both remote to and incorporated in the device.

Further, the system may comprise any of the following:

A primary coil in the external energy source adapted to transmit the wireless energy inductively to a secondary coil in the internal energy receiver.

The determination device is adapted to detect a change in the energy balance, and the control device controls the transmission of wireless energy based on the detected energy balance change

The determination device is adapted to detect a difference between energy received by the internal energy receiver and energy used for the implantable energy consuming components of the apparatus, and the control device controls the transmission of wireless energy based on the detected energy difference.

The control device controls the external energy-transmission device to decrease the amount of transmitted wireless energy if the detected energy balance change implies that the energy balance is increasing, or vice versa, wherein the decrease/increase of energy transmission corresponds to a detected change rate.

The control device controls the external energy-transmission device to decrease the amount of transmitted wireless energy if the detected energy difference implies that the received energy is greater than the used energy, or vice versa, wherein the decrease/increase of energy transmission corresponds to the magnitude of said detected energy difference.

The energy used for the apparatus is consumed to operate the apparatus, and/or stored in at least one energy storage device of the apparatus.

Where electrical and/or physical parameters of the apparatus and/or physical parameters of the patient are determined, the energy-transmission device transmits the energy for consumption and storage according to a transmission rate per time unit which is determined by the determination device based on said parameters. The determination device also determines the total amount of transmitted energy based on said parameters.

When a difference is detected between the total amount of energy received by the internal energy receiver and the total amount of consumed and/or stored energy, and the detected difference is related to the integral over time of at least one measured electrical parameter related to the energy balance, the determination device determines the integral for a monitored voltage and/or current related to the energy balance.

When the derivative is determined over time of a measured electrical parameter related to the amount of consumed and/or stored energy, the determination device determines the derivative for a monitored voltage and/or current related to the energy balance.

The energy-transmission device comprises a coil placed externally to the human body, and an electric circuit is provided to power the external coil with electrical pulses to transmit the wireless energy. The electrical pulses have leading and trailing edges, and the electric circuit is adapted to vary first time intervals between successive

leading and trailing edges and/or second time intervals between successive trailing and leading edges of the electrical pulses to vary the power of the transmitted wireless energy. As a result, the energy receiver receiving the transmitted wireless energy has a varied power.

The electric circuit is adapted to deliver the electrical pulses to remain unchanged except varying the first and/or second time intervals.

The electric circuit has a time constant and is adapted to vary the first and second time intervals only in the range of the first time constant, so that when the lengths of the first and/or second time intervals are varied, the transmitted power over the coil is varied.

The electric circuit is adapted to deliver the electrical pulses to be varied by only varying the lengths of first time intervals between successive leading and trailing edges of the electrical pulses.

The electric circuit is adapted to supplying a train of two or more electrical pulses in a row, said train having a first electrical pulse at the start of the pulse train and having a second electrical pulse at the end of the pulse train, and the lengths of the second time intervals between successive trailing edge of the second electrical pulse in a first pulse train and leading edge of the first electrical pulse of a second pulse train are varied by the first electronic circuit.

The electric circuit is adapted to provide the electrical pulses as pulses having a substantially constant height and/or amplitude and/or intensity and/or voltage and/or current and/or frequency.

The electric circuit has a time constant, and is adapted to vary the first and second time intervals only in the range of the first time constant, so that when the lengths of the first and/or second time intervals are varied, the transmitted power over the first coil are varied.

The electric circuit is adapted to provide the electrical pulses varying the lengths of the first and/or the second time intervals only within a range that includes the first time constant or that is located relatively close to the first time constant, compared to the magnitude of the first time constant.

FIGS. **42-45** show in more detail block diagrams of four different ways of hydraulically or pneumatically powering an implanted apparatus according to the invention.

FIG. **42** shows a system as described above with. The system comprises an implanted apparatus **10** and further a separate regulation reservoir **1013**, a one way pump **1009** and an alternate valve **1014**.

FIG. **43** shows the apparatus **10** and a fluid reservoir **1013**. By moving the wall of the regulation reservoir or changing the size of the same in any other different way, the adjustment of the apparatus may be performed without any valve, just free passage of fluid any time by moving the reservoir wall.

FIG. **44** shows the apparatus **10**, a two way pump **1009** and the regulation reservoir **1013**.

FIG. **45** shows a block diagram of a reversed servo system with a first closed system controlling a second closed system. The servo system comprises a regulation reservoir **1013** and a servo reservoir **1050**. The servo reservoir **1050** mechanically controls an implanted apparatus **10** via a mechanical interconnection **1054**. The apparatus has an expandable/contactable cavity. This cavity is preferably expanded or contracted by supplying hydraulic fluid from the larger adjustable reservoir **1052** in fluid connection with the apparatus **10**. Alternatively, the cavity contains compressible gas, which can be compressed and expanded under the control of the servo reservoir **1050**.

The servo reservoir **1050** can also be part of the apparatus itself.

In one embodiment, the regulation reservoir is placed subcutaneous under the patient's skin and is operated by pushing the outer surface thereof by means of a finger. This system is illustrated in FIGS. **46a-c**. In FIG. **46a**, a flexible subcutaneous regulation reservoir **1013** is shown connected to a bulge shaped servo reservoir **1050** by means of a conduit **1011**. This bellow shaped servo reservoir **1050** is comprised in a flexible apparatus **10**. In the state shown in FIG. **46a**, the servo reservoir **1050** contains a minimum of fluid and most fluid is found in the regulation reservoir **1013**. Due to the mechanical interconnection between the servo reservoir **1050** and the apparatus **10**, the outer shape of the apparatus **10** is contracted, i.e., it occupies less than its maximum volume. This maximum volume is shown with dashed lines in the figure.

FIG. **46b** shows a state wherein a user, such as the patient in with the apparatus is implanted, presses the regulation reservoir **1013** so that fluid contained therein is brought to flow through the conduit **1011** and into the servo reservoir **1050**, which, thanks to its bellow shape, expands longitudinally. This expansion in turn expands the apparatus **10** so that it occupies its maximum volume, thereby stretching the stomach wall (not shown), which it contacts.

The regulation reservoir **1013** is preferably provided with means **1013a** for keeping its shape after compression. This means, which is schematically shown in the figure, will thus keep the apparatus **10** in a stretched position also when the user releases the regulation reservoir. In this way, the regulation reservoir essentially operates as an on/off switch for the system.

An alternative embodiment of hydraulic or pneumatic operation will now be described with reference to FIGS. **47** and **48a-c**. The block diagram shown in FIG. **47** comprises with a first closed system controlling a second closed system. The first system comprises a regulation reservoir **1013** and a servo reservoir **1050**. The servo reservoir **1050** mechanically controls a larger adjustable reservoir **1052** via a mechanical interconnection **1054**. An implanted apparatus **10** having an expandable/contactable cavity is in turn controlled by the larger adjustable reservoir **1052** by supply of hydraulic fluid from the larger adjustable reservoir **1052** in fluid connection with the apparatus **10**.

An example of this embodiment will now be described with reference to FIG. **48a-c**. Like in the previous embodiment, the regulation reservoir is placed subcutaneous under the patient's skin and is operated by pushing the outer surface thereof by means of a finger. The regulation reservoir **1013** is in fluid connection with a bellow shaped servo reservoir **1050** by means of a conduit **1011**. In the first closed system **1013**, **1011**, **1050** shown in FIG. **48a**, the servo reservoir **1050** contains a minimum of fluid and most fluid is found in the regulation reservoir **1013**.

The servo reservoir **1050** is mechanically connected to a larger adjustable reservoir **1052**, in this example also having a bellow shape but with a larger diameter than the servo reservoir **1050**. The larger adjustable reservoir **1052** is in fluid connection with the apparatus **10**. This means that when a user pushes the regulation reservoir **1013**, thereby displacing fluid from the regulation reservoir **1013** to the servo reservoir **1050**, the expansion of the servo reservoir **1050** will displace a larger volume of fluid from the larger adjustable reservoir **1052** to the apparatus **10**. In other words, in this reversed servo, a small volume in the regulation reservoir is compressed with a higher force and this creates a movement of a larger total area with less force per area unit.

Like in the previous embodiment described above with reference to FIGS. **46a-c**, the regulation reservoir **1013** is preferably provided with means **1013a** for keeping its shape after compression. This means, which is schematically shown in the figure, will thus keep the apparatus **10** in a stretched position also when the user releases the regulation reservoir. In this way, the regulation reservoir essentially operates as an on/off switch for the system.

One single volume filling device has been described as invaginated in the stomach wall. Alternatively, two or more volume filling devices **10** may be invaginated to obtain the desired reduction of the food cavity. One such example is illustrated in FIG. **48**, wherein three ball-shaped volume filling devices **10** are invaginated in the wall of the patient's stomach **12**.

It has been described how the volume filling device **10** is invaginated in the stomach wall by means of a gastroscopic instrument. It will be appreciated that abdominal operation methods can be used as well. Such methods will now be described in detail with reference to FIGS. **49a** and **49b**.

In a first alternative embodiment, the volume filling device is implanted using a laparoscopic method instead of the intraluminal method described above. According to this embodiment, a needle or a tube-like instrument is inserted into the abdomen of the patient's body, and said needle or tube-like instrument is then used to fill the patient's abdomen with gas. Subsequently, at least two laparoscopic trocars are inserted into the patient's body; and a camera is inserted through one of said at least two laparoscopic trocars. Then, at least one dissecting tool through one of said at least two laparoscopic trocars, and an area of the stomach is dissected. The volume filling device is then introduced into the abdominal cavity, and placed on the outside of the stomach wall. A pouch in the stomach wall for the device is created, and the device invaginated in said pouch by providing sutures or staples to the stomach wall, thereby positioning the volume filling device so that the volume of the food cavity is reduced in size by a volume substantially exceeding the volume of the volume filling device.

The above first alternative preferably further comprises affixing the device to the stomach wall by providing sutures or staples.

The above embodiment preferably further comprises providing an apparatus for regulating the obesity treatment device from the outside of the patient's body; and operating said apparatus to regulate the obesity treatment device. Further, regulation of the obesity treatment device includes changing the volume of a filling body of the volume filling device when implanted.

The above embodiment preferably further comprises providing an injection type syringe comprising a fluid for injection into an implanted filling body; and injecting volume of fluid into said filling body.

According to an embodiment, the device is enclosed in the pouch or partially enclosed in that the pouch is left at least partly open. Further, the pouch can be designed to exhibit only one opening. Alternatively the pouch is designed to exhibit two openings and to extend non-circumferentially around the stomach.

Preferably the pouch has a volume of more than 15 milliliters.

In a second alternative, also using a laparoscopic method instead of the intraluminal method, the initial steps are the same as described in the first alternative, but following dissection of the stomach, a hole is created in the stomach wall and a volume filling device introduced into the abdominal cavity and through said hole into the stomach. The device is

placed on the inside of the stomach wall, and a pouch is created on the outside of the stomach cavity for the device placed on the inside of the stomach wall, and the device is invaginated in the pouch by providing sutures or staples to the stomach wall, thereby positioning the volume filling device so that the volume of the food cavity is reduced in size by a volume substantially exceeding the volume of the volume filling device.

The above embodiment preferably further comprises affixing the device to the stomach wall by providing sutures or staples. According to one embodiment, the stomach wall is affixed to the lower part of the patient's esophagus by providing sutures or staples.

The above second alternative preferably further comprises providing an apparatus for regulating the obesity treatment device from the outside of the patient's body; and operating said apparatus to regulate the obesity treatment device. Further, regulation of the obesity treatment device includes changing the volume of a filling body of the volume filling device when implanted.

The above embodiment preferably further comprises providing an injection type syringe comprising a fluid for injection into an implanted filling body; and injecting volume of fluid into said filling body.

According to an embodiment, the device is enclosed in the pouch or partially enclosed in that the pouch is left at least partly open. Further, the pouch can be designed to exhibit only one opening. Alternatively the pouch is designed to exhibit two openings and to extend non-circumferentially around the stomach.

Preferably the pouch has a volume of more than 15 milliliters.

A third alternative involves a surgical incision instead of the either the intraluminal or the laparoscopic method. Here, an opening in the patient's abdominal wall is made by surgical incision, and an area of the patient's stomach is dissected. The volume filling device is introduced through said abdominal incision, and attached to the stomach wall, thereby positioning the volume filling device so that the volume of the food cavity is reduced in size by a volume substantially exceeding the volume of the volume filling device.

In an alternative embodiment of the above, third alternative, the initial steps are the same including the dissection of an area of the stomach. Following this, a pouch in the stomach wall is created for the device, and the device invaginated in the pouch by providing sutures or staples to the stomach wall, thereby positioning the volume filling device so that the volume of the food cavity is reduced in size by a volume substantially exceeding the volume of the volume filling device.

In yet another alternative embodiment of the above, third alternative, the initial steps are the same including the dissection of an area of the stomach. Following this, a hole in the stomach wall is created and the volume filling device introduced through the hole and into the stomach. The device is then placed on the inside of the stomach wall, and a pouch on the stomach wall created for the device. The device is then invaginated in the pouch by providing sutures or staples to the stomach wall, thereby positioning the volume filling device so that the volume of the food cavity is reduced in size by a volume substantially exceeding the volume of the volume filling device.

The above embodiments of the third alternative further comprise affixing the device to the stomach wall by providing sutures or staples.

The above embodiment preferably further comprises providing an apparatus for regulating the obesity treatment device from the outside of the patient's body; and operating

said apparatus to regulate the obesity treatment device. Further, regulation of the obesity treatment device includes changing the volume of a filling body of the volume filling device when implanted.

The above embodiment preferably further comprises providing an injection type syringe comprising a fluid for injection into an implanted filling body; and injecting volume of fluid into said filling body.

According to an embodiment, the device is enclosed in the pouch or partially enclosed in that the pouch is left at least partly open. Further, the pouch can be designed to exhibit only one opening. Alternatively the pouch is designed to exhibit two openings and to extend non-circumferentially around the stomach.

Preferably the pouch has a volume of more than 15 milliliters.

A fourth alternative embodiment is a method comprising the steps of inserting a needle or a tube-like instrument into the abdomen of the patient's body; using said needle or tube-like instrument to fill the patient's abdomen with gas; placing at least two laparoscopic trocars in the patient's body; inserting a camera through one of said at least two laparoscopic trocars into the patient's abdomen; inserting at least one dissecting tool through one of said at least two laparoscopic trocars; dissecting an area of the stomach; creating a pouch from the stomach wall for the device; closing the pouch by providing sutures and staples; introducing a injecting member comprising an injectable filling material; and injecting the filling material into the pouch, thereby creating a filling body that fills a volume in the patient's stomach, reducing the food cavity in size by a volume substantially exceeding the volume of the volume filling device.

Instead of the above disclosed laparoscopic method, a surgical incision or opening is cut in the skin to enter the patient's abdomen; an area of the stomach dissected; a pouch created from the stomach wall for the device; and said pouch closed by providing sutures and staples. An injecting member comprising an injectable filling material is then introduced; and the filling material injected into the pouch, thereby creating a filling body that reduces the food cavity in size by a volume substantially exceeding the volume of the volume filling device.

According to an alternative embodiment of the above, the pouch is created on the outside of the stomach wall, with the filling body placed against the inside of the stomach wall.

The method according to either of the two previous embodiments comprises creating a hole in the stomach wall wherein the pouch is created on the inside of the stomach wall, with the filling body placed against the outside of the stomach wall.

The method according to either of the two previous embodiments may further comprise affixing the stomach wall to the lower part of the patient's esophagus by providing sutures or staples or affixing the stomach wall to the patient's diaphragm muscle or associated muscles.

Preferably the pouch has a volume of more than 15 milliliters.

In a method according to either of the two previous embodiments the filling material is preferably capable of undergoing a curing process from a fluid state to a semi-solid or solid state. Preferably said curing process is triggered by an increase in temperature from ambient temperature to body temperature.

The invention also makes available a method of treating obesity in a patient by implanting a volume filling device that, when implanted in a patient, reduces the food cavity in size by

a volume substantially exceeding the volume of the volume filling device, the method comprising the steps of:
 inserting a needle or a tube-like instrument into the abdomen of the patient's body;
 using said needle or tube-like instrument to fill the patient's abdomen with gas;
 placing at least two laparoscopic trocars in the patient's body;
 inserting a camera through one of said at least two laparoscopic trocars into the patient's abdomen;
 inserting at least one dissecting tool through one of said at least two laparoscopic trocars;
 dissecting an area of the stomach;
 creating a hole in the stomach wall;
 introducing a device into the abdominal cavity;
 introducing the device through the hole and into the stomach;
 placing the device on the outside of the stomach wall;
 fixating the device placed on the outside of the stomach wall, and
 thereby creating a filling body that reduces the food cavity in size by a volume substantially exceeding the volume of the volume filling device.

In the above method, the device is preferably affixed to the stomach wall by providing sutures or staples.

The invention also comprises a laparoscopic instrument for providing a volume filling device to be invaginated in the stomach wall of a human patient to treat obesity, suitable for use with any of the laparoscopic methods described above, the instrument comprising:

an elongated member having a proximal end and a distal end, the elongated member having a diameter less than that of a laparoscopic trocar to be introduced into the patient's abdomen during a laparoscopic operation;

a stomach pushing device for pushing the stomach wall to create a tube-like shaped portion of the stomach wall protruding into the normal stomach cavity, said pushing device comprising the volume filling device to be invaginated by the stomach wall in the tube-like shaped portion thereof;

wherein the pushing device comprises a vacuum device to suck the stomach fundus to assist the instrument in forming the tube-like shaped portion of the stomach wall together with the pushing device, and wherein the vacuum device comprises a vacuum passageway leading from the proximal to the distal end of the instrument and at the end portion of the instrument, which includes the pushing device, said vacuum passageway is divided up in multiple small openings adapted to suck the stomach wall portion to become adherent to the pushing device to further form the tube-like stomach wall portion; and

wherein the instrument comprises an insertion device adapted to introduce the volume filling device into the tube-like shaped stomach portion.

This instrument preferably comprises at least one clamping device for holding the opening of the tube-like portion substantially closed by clamping together stomach to stomach in said opening, wherein the instrument is adapted to place the at least one clamping device at the opening in such a way that it allows later suturing of the opening.

Further, the instrument preferably comprises an inflation device for inflating the volume filling device before or after the suturing. Further still, the instrument preferably comprises a suturing device adapted to suture the opening of the tube-like portion with stomach to stomach sutures for creating at least partly a closed space enclosing the volume filling device, wherein the instrument is adapted to be withdrawn leaving the volume filling device at least partly invaginated in the stomach wall.

Said suturing device preferably comprises a first and second suture positioning member provided on the elongated member situated in the stomach at the distal end thereof, and wherein the instrument further comprises an operation device adapted to adjust the first and second suturing member in a position in which the first and second suture positioning members are in front of each other with the stomach wall on both sides of the open end of the cup like portion, and adapted to suture the open end of the cup like portion of the wall with a row of stomach to stomach sutures.

Preferably said suturing device comprises an operable reloadable multi-suturing device, which is reloadable with sutures from outside of the patient's body and which is adapted to suture the open end of the cup like portion of the wall with said row of stomach to stomach sutures, wherein the row of sutures comprises two or more sutures or staples to be sutured simultaneously.

More preferably, said suturing device comprises multiple sutures for suturing two or more sutures simultaneously.

It is understood that a skilled person is in the position of combining steps, changing the order of steps, and combining elements of the different embodiments of the invention without inventive effort, and without departing from the scope of the invention as defined in the description and claims.

The invention claimed is:

1. A method for treating obesity in a patient having a stomach with a food cavity by implanting a volume filling device that, when implanted in a patient, reduces said food cavity in size by a volume substantially exceeding the volume of said volume filling device, the method comprising the steps of:

inserting a needle or a tube-like instrument into the abdomen of the patient's body;

using said needle or tube-like instrument to fill the patient's abdomen with gas;

placing at least two laparoscopic trocars in the patient's body;

inserting a camera through one of said at least two laparoscopic trocars into the patient's abdomen,

inserting at least one dissecting tool through one of said at least two laparoscopic trocars;

dissecting an area of the stomach;

introducing the volume filling device into the abdominal cavity;

placing the volume filling device on the outside of the stomach wall;

creating a pouch in the stomach wall, sealed from the stomach cavity, from the outside of the stomach wall,

wherein the pouch is created from the tissue of the stomach wall and adapted for the volume filling device; and

completely enclosing the volume filling device by invaginating and sealing the volume filling device in the pouch

by providing stomach to stomach sutures or staples to the stomach wall from the outside of the stomach wall,

thereby positioning the volume filling device so that the volume of the food cavity is reduced in size by a volume substantially exceeding the volume of the volume filling device, and

introducing a non-invasive regulation apparatus for non-invasively regulating the volume filling device from the outside of the patient's body.

2. The method according to claim 1, further comprising affixing the volume filling device to the stomach wall by providing sutures or staples reaching from the volume filling device to the stomach wall.

3. The method according to claim 1, further comprising affixing the stomach wall to the lower part of the patient's esophagus by providing sutures or staples.

4. The method according to claim 1, further comprising affixing the stomach wall to the patient's diaphragm muscle or associated muscles. 5

5. The method according to claim 1, further comprising operating said apparatus to non-invasively regulate the volume filling device.

6. The method according to claim 5, wherein regulation of the volume filling device includes changing the volume of a filling body of the volume filling device when implanted. 10

7. The method according to claim 6, comprising providing an injection type syringe comprising a fluid for injection into the implanted filling body; and 15

injecting volume of fluid into said filling body.

8. The method according to claim 1, wherein the pouch has a volume of more than 15 milliliters.

9. A method of treating obesity in a patient having a stomach with a food cavity by implanting a volume filling device that, when implanted in a patient, reduces said food cavity in size by a volume substantially exceeding the volume of the volume filling device, the method comprising the steps of: 20

inserting a needle or a tube-like instrument into the abdomen of the patient's body;

using the needle or tube-like instrument to fill the patients abdomen with gas; 25

placing at least two laparoscopic trocars in the patient's body;

inserting a camera through one of said at least two laparoscopic trocars into the patient's abdomen; 30

inserting at least one dissecting tool through one of said at least two laparoscopic trocars;

dissecting an area of the stomach;

creating a hole in the stomach wall; 35

introducing a volume filling device into the abdominal cavity;

introducing the Volume filling device through the hole and into the stomach;

placing the volume filling device on the inside of stomach wall; 40

creating a pouch from tissue of the stomach wall, sealed from the stomach cavity, on the outside of the stomach

cavity for the device placed on the inside of the stomach wall, and completely enclosing the volume filling device by invaginating and sealing the volume filling device in the pouch by providing stomach to stomach sutures or staples from the outside of the stomach wall, thereby positioning the volume filling device so that the volume of the food cavity is reduced in size by a volume substantially exceeding the volume of the volume filling device.

10. The method according to claim 9, further comprising affixing the volume filling device to the stomach wall by providing sutures or staples reaching from the volume filling device to the stomach wall.

11. The method according to claim 9, further comprising affixing the stomach wall to the lower part of the patient's esophagus by providing sutures or staples.

12. The method according to claim 9, further comprising affixing the stomach wall to the patient's diaphragm muscle or associated muscles.

13. The method according to claim 9, further comprising providing an apparatus for regulating the volume filling device from the outside of the patient's body.

14. The method according to claim 13, wherein regulation of the volume filling device includes changing the volume of as filling body of the volume filling device when implanted.

15. The method according to claim 14, comprising providing an injection type syringe comprising a fluid for injection into the implanted filling body; and 30

injecting volume of fluid into filling body.

16. The method according to claim 13, further comprising the step of operating said apparatus to regulate the volume filling device.

17. The method according to claim 13, wherein the step of providing an apparatus for regulating the volume filling device from the outside of the patient's body, comprises providing a non-invasive regulation apparatus for non-invasively regulating the volume filling device.

18. The method according to claim 17, further comprising the step of operating said apparatus to non-invasively regulate the volume filling device.

* * * * *

专利名称(译)	治疗肥胖症的方法和仪器		
公开(公告)号	US9375213	公开(公告)日	2016-06-28
申请号	US12/864718	申请日	2009-01-29
[标]申请(专利权)人(译)	福塞尔PETER		
申请(专利权)人(译)	福塞尔PETER		
当前申请(专利权)人(译)	福塞尔, PETER		
[标]发明人	FORSELL PETER		
发明人	FORSELL, PETER		
IPC分类号	A61M29/00 A61F2/04 A61B17/068 A61B1/273 A61B1/04 A61B1/313 A61B17/064 A61B17/32 A61B17/34 A61F5/00 A61B17/04 A61B17/08 A61B17/00 A61B17/30		
CPC分类号	A61B17/08 A61B1/04 A61B1/2736 A61B1/3132 A61B17/0469 A61B17/064 A61B17/068 A61B17/320016 A61B17/3423 A61B17/3474 A61F2/04 A61F5/003 A61F5/004 A61F5/005 A61F5/0033 A61F5/0036 A61F5/0043 A61F5/0046 A61F5/0069 A61F5/0073 A61F5/0086 A61F5/0089 A61B2017/00278 A61B2017/00561 A61B2017/00818 A61B2017/00827 A61B2017/081 A61B2017/306 A61B2017/308 A61F2002/045 A61F2005/002 A61F2005/0016 A61F2005/0023 A61F2250/0001 A61F2250/0004 A61F5/0063 A61B17/00234 A61B17/0682 A61F5/0003 A61F5/0013 A61F5/0026 A61F5/0076 A61F5/0079 A61N1/36007 A61B17/00 A61B17/30 A61F2002/044		
优先权	0802138 2008-10-10 SE		
其他公开文献	US20100312047A1		
外部链接	Espacenet USPTO		

摘要(译)

本发明涉及通过植入体积填充装置来治疗患者肥胖的手术腹部方法，所述体积填充装置在植入患者体内时，通过基本上超过所述容积填充装置的体积的体积来减小食物腔的尺寸。还公开了一种腹腔镜器械，用于提供容纳在人类患者胃壁中的容积填充装置以治疗肥胖症。

