



US 20200078007A1

(19) **United States**

(12) **Patent Application Publication**
O'Hara et al.

(10) **Pub. No.: US 2020/0078007 A1**

(43) **Pub. Date: Mar. 12, 2020**

(54) **LAPAROSCOPIC SUTURING DEVICES,
NEEDLES, SUTURES, AND DRIVE SYSTEMS**

(52) **U.S. Cl.**
CPC *A61B 17/0469* (2013.01); *A61B 17/0625*
(2013.01); *A61B 17/0482* (2013.01); *A61B*
17/06004 (2013.01); *A61B 17/06066*
(2013.01); *A61B 17/29* (2013.01); *A61B*
17/06166 (2013.01); *A61B 17/0491* (2013.01);
A61B 17/0487 (2013.01); *A61B 17/0485*
(2013.01); *A61B 17/06114* (2013.01)

(71) Applicant: **ReViable Surgical, Inc.**, Lutz, FL (US)

(72) Inventors: **Derek M. O'Hara**, Lutz, FL (US);
Daniel E. Johns, Winter Park, FL (US);
Peter J. Meinz, Minneapolis, MN (US)

(21) Appl. No.: **16/682,138**

(22) Filed: **Nov. 13, 2019**

(57) **ABSTRACT**

Related U.S. Application Data

(63) Continuation-in-part of application No. 16/439,488, filed on Jun. 12, 2019, which is a continuation of application No. 15/792,749, filed on Oct. 24, 2017, now Pat. No. 10,143,465.

(60) Provisional application No. 62/411,830, filed on Oct. 24, 2016, provisional application No. 62/767,964, filed on Nov. 15, 2018.

Publication Classification

(51) **Int. Cl.**
A61B 17/04 (2006.01)
A61B 17/062 (2006.01)
A61B 17/06 (2006.01)

Devices are provided for a suturing device used during laparoscopic surgical procedures. A suturing needle includes a shaft forming a rod axis; a curved body having a piercing tip at a first end and a base at a second end; and an arm extending from the shaft to the base of the curved body such that the curved body is rotatable about the shaft. The suturing device includes a housing, a suturing needle, one or more sutures, a suture magazine configured to hold the one or more sutures, and a drive system, whereby the drive system may actuate the suturing needle to rotate, allowing the suturing needle to drive into and out of tissue to apply a suture.

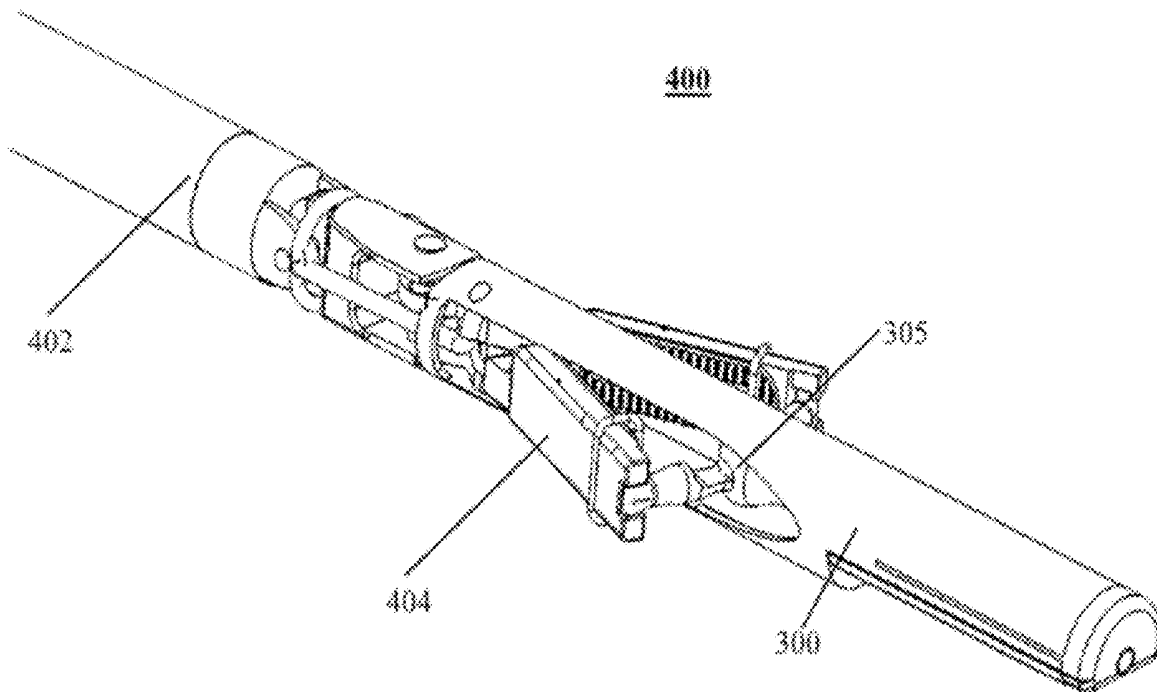

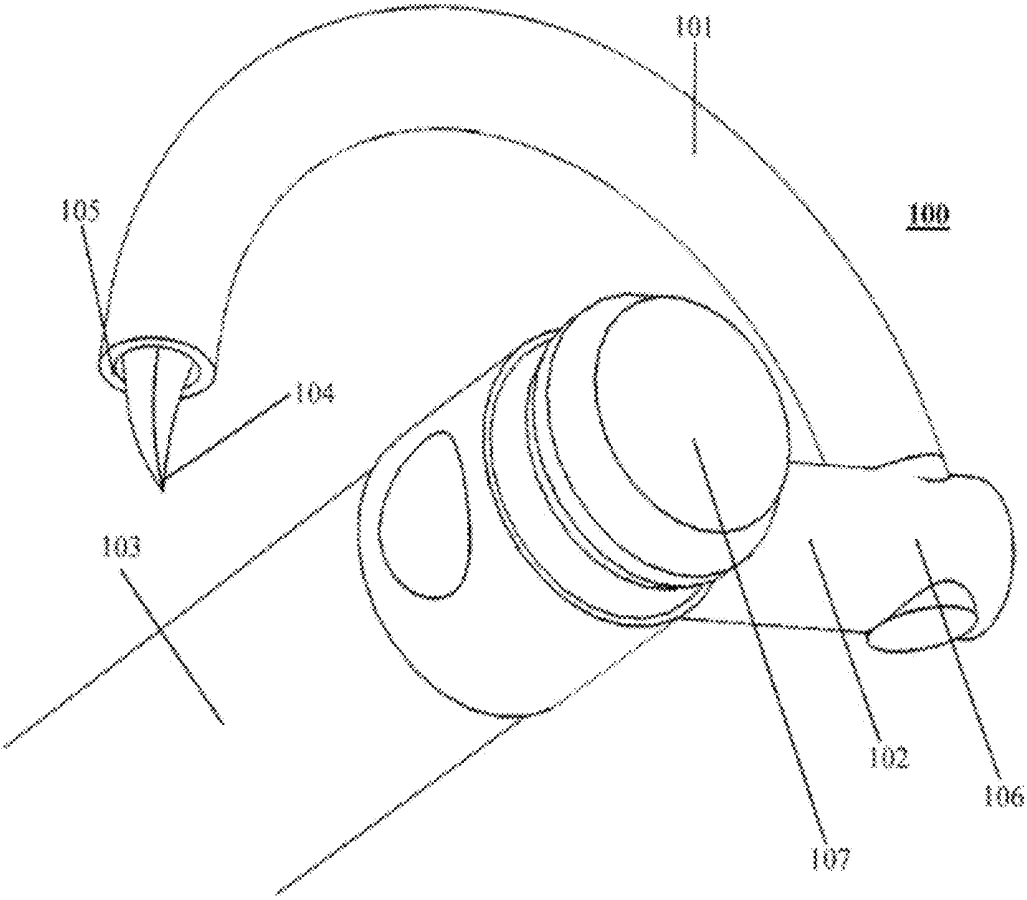

FIG. 1A

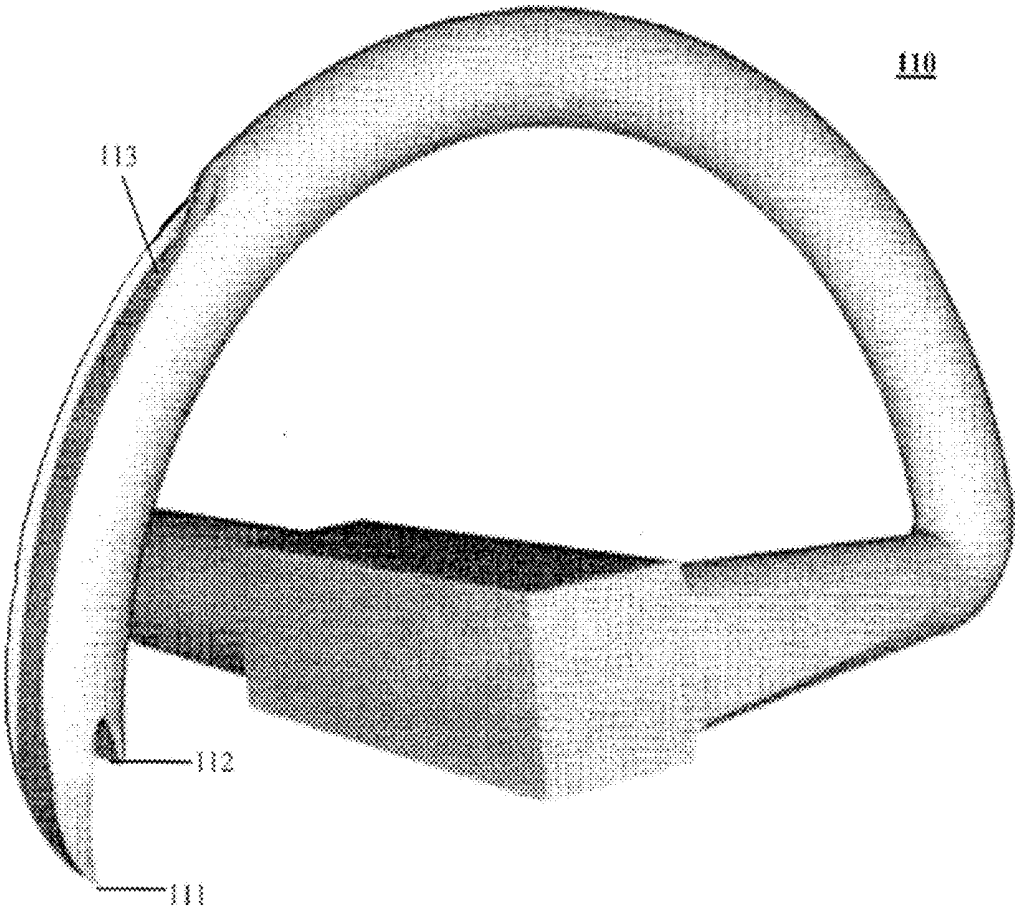

FIG. 1B

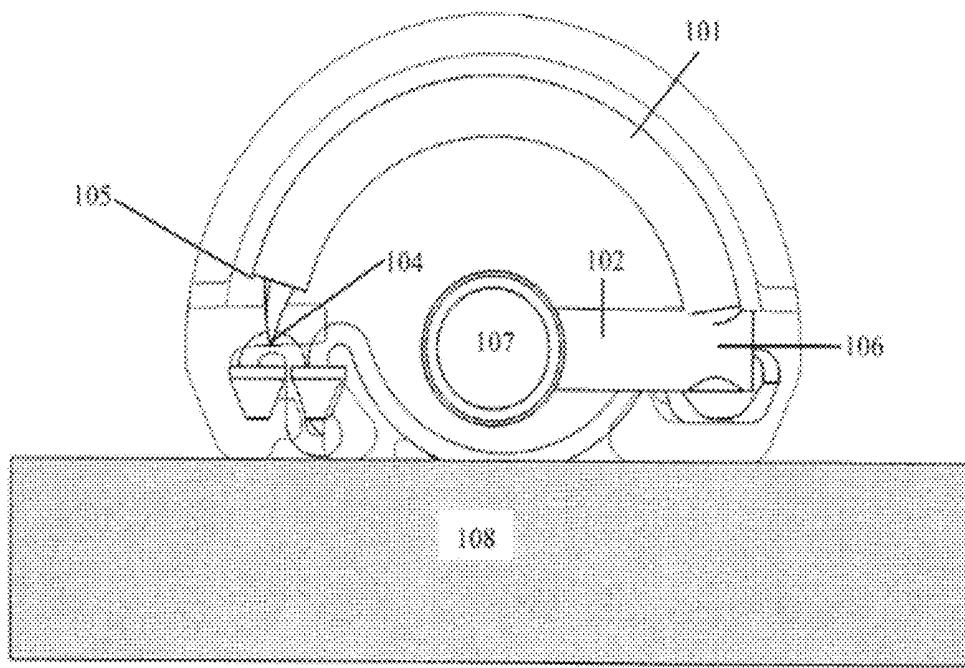

FIG. 1C

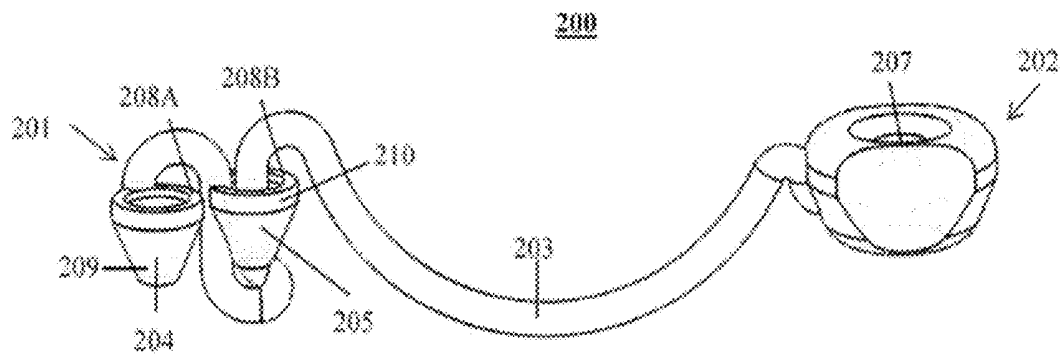

FIG. 2A

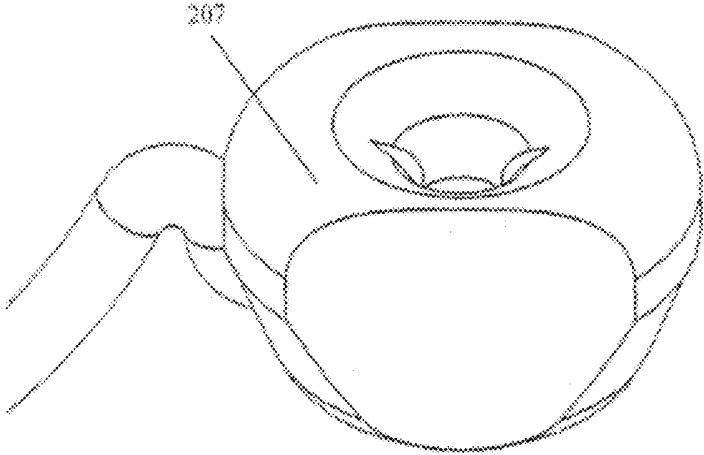

FIG. 2B

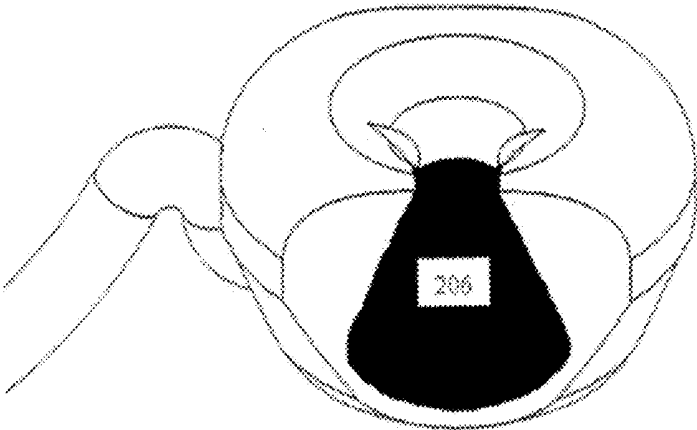

FIG. 2C

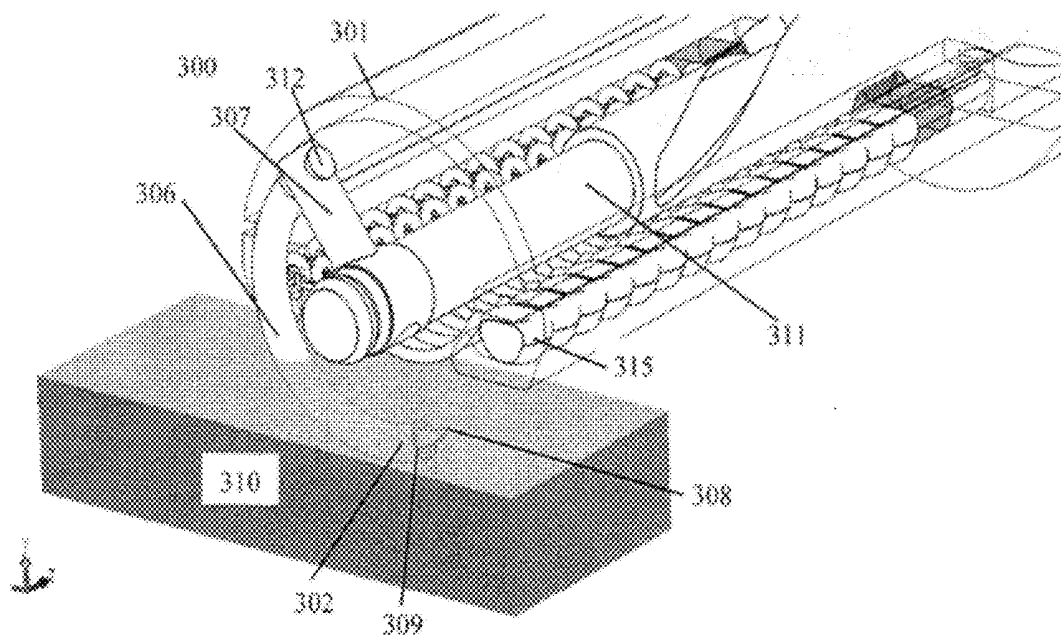

FIG. 3A

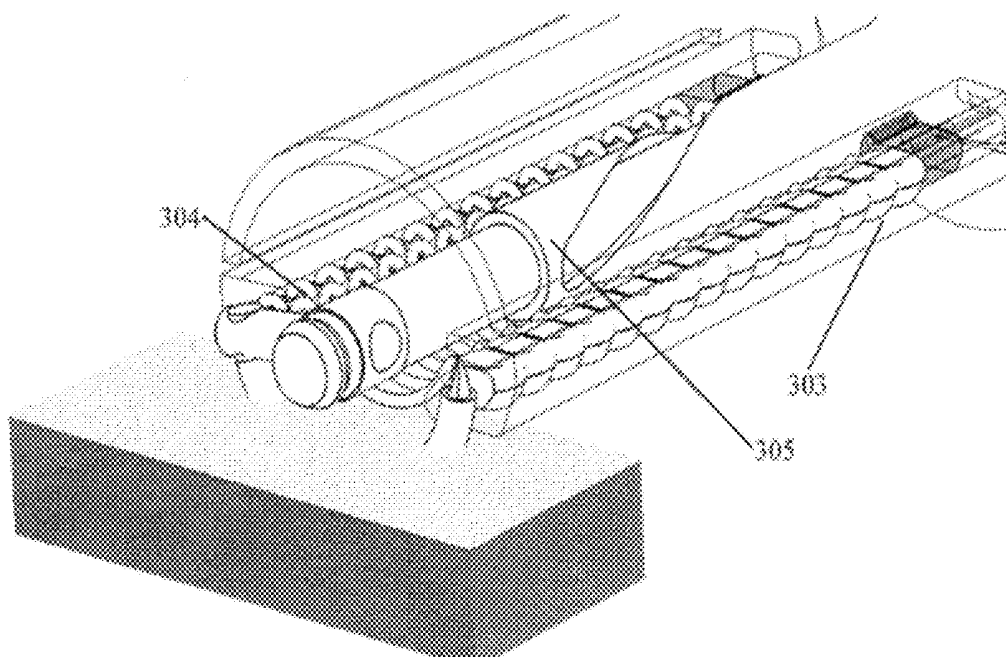

FIG. 3B

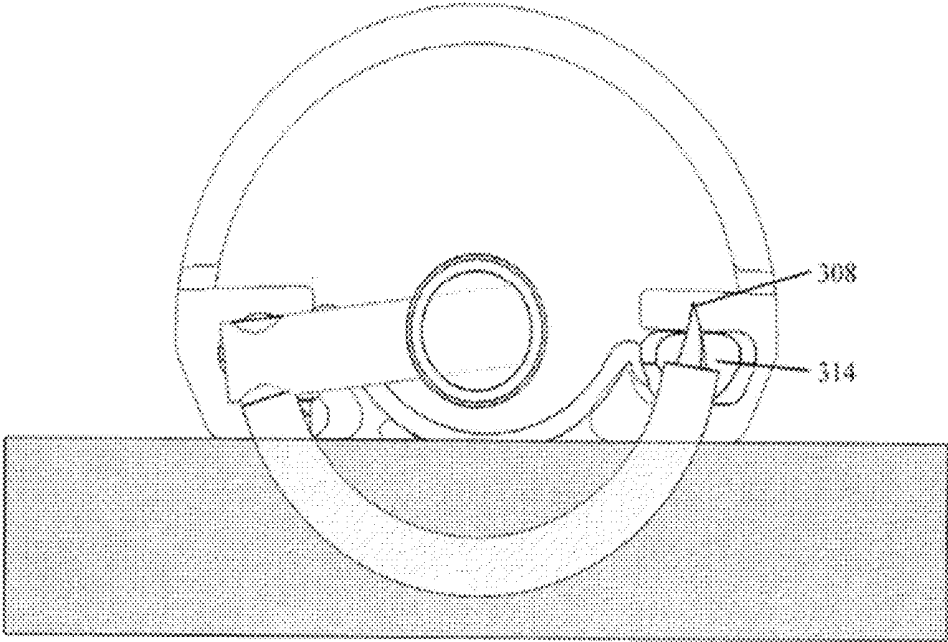

FIG. 3C

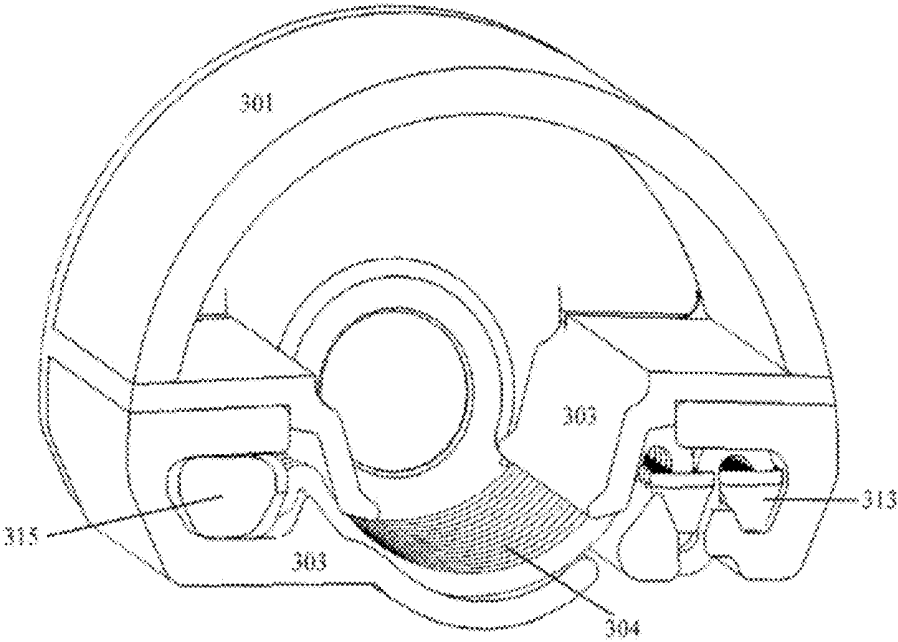

FIG. 3D

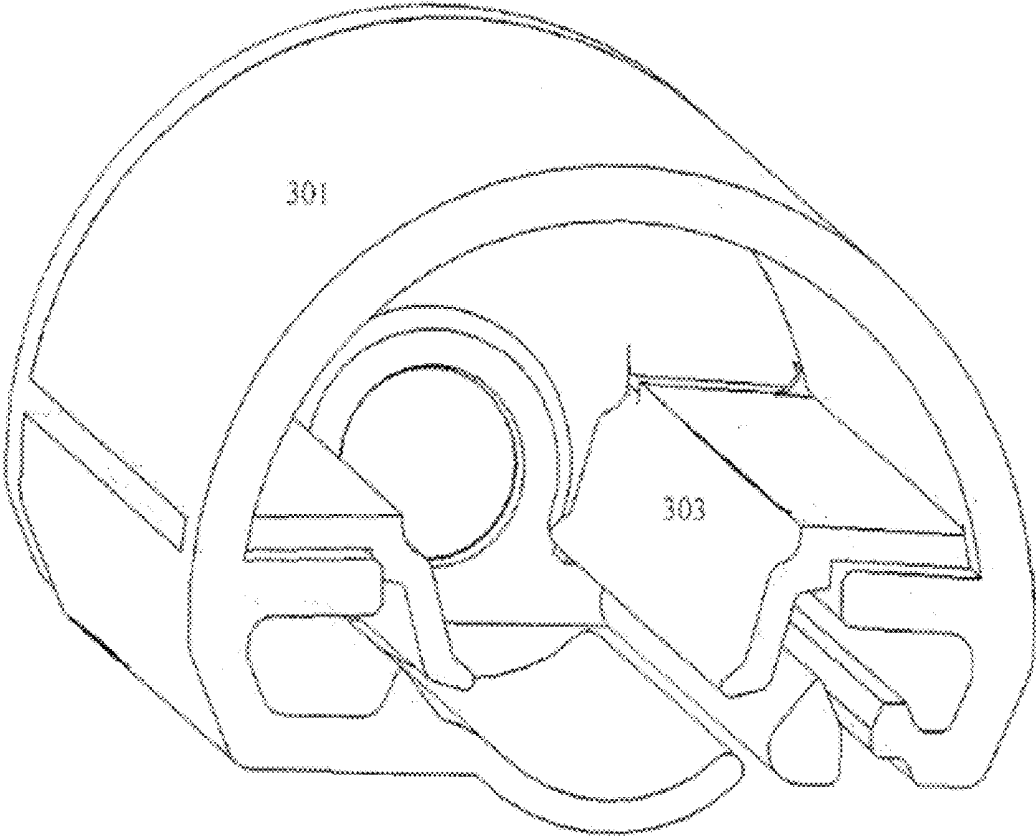

FIG. 3E

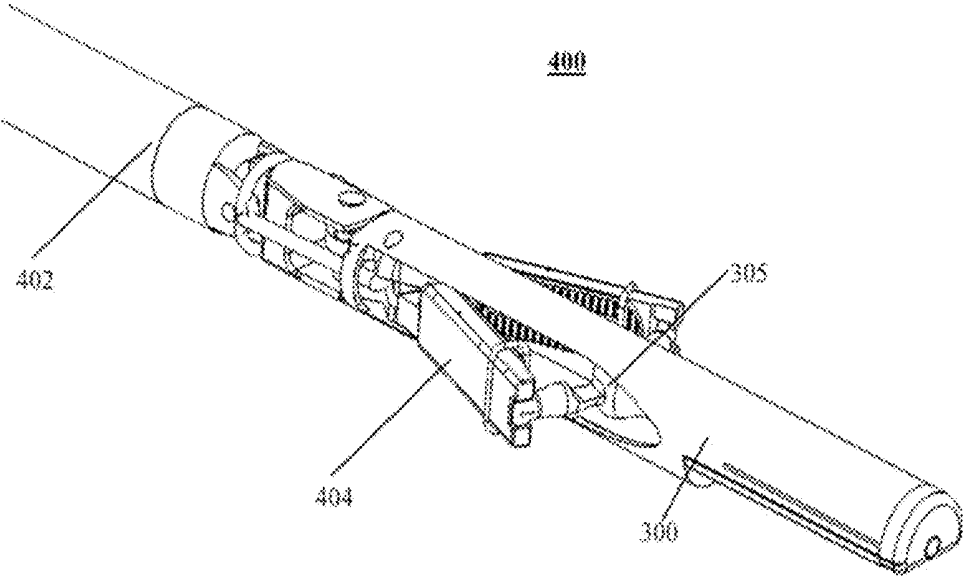

FIG. 4

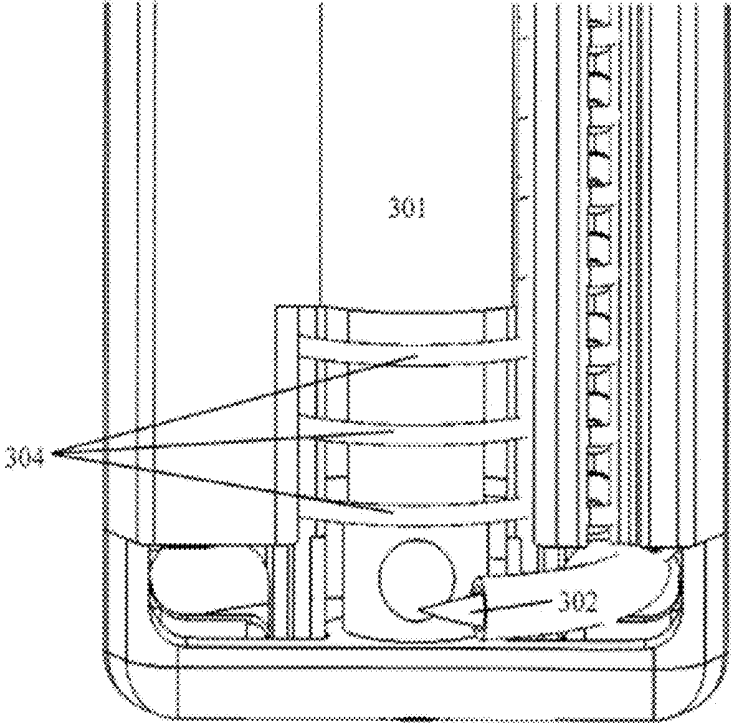

FIG. 5A

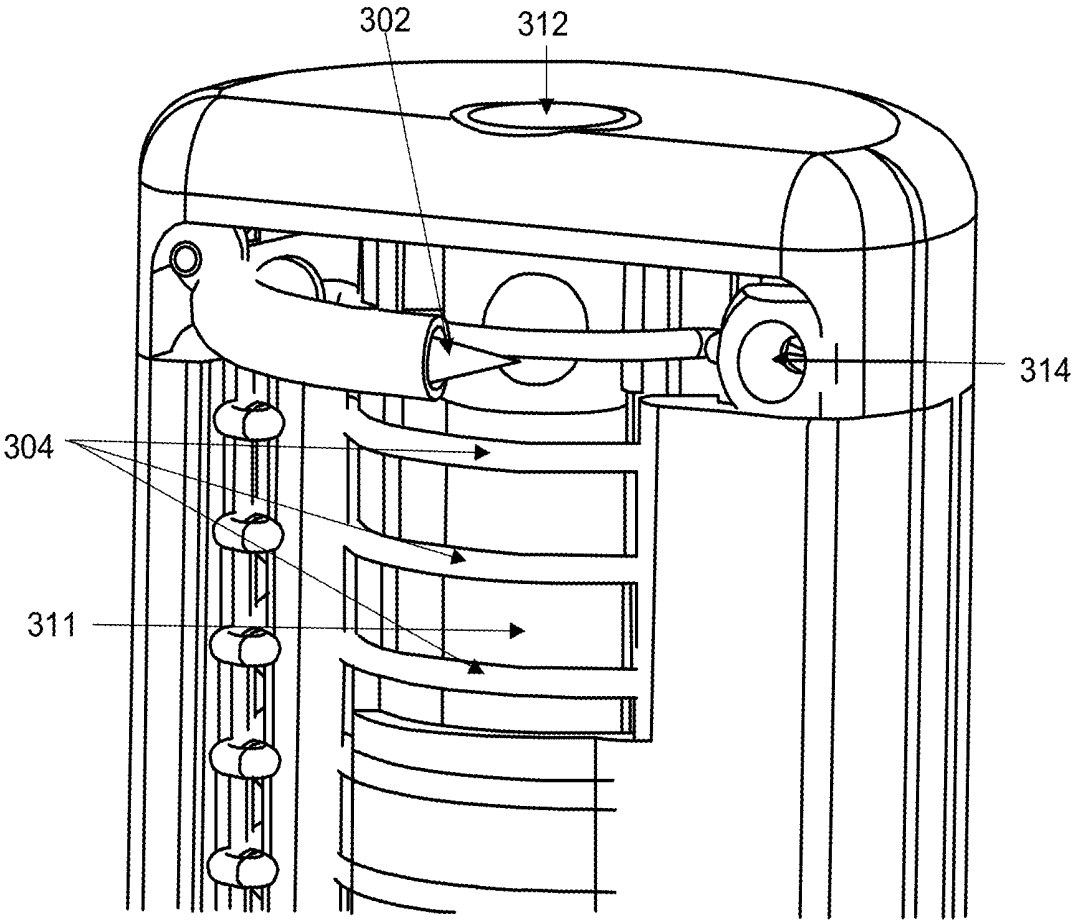

FIG. 5B

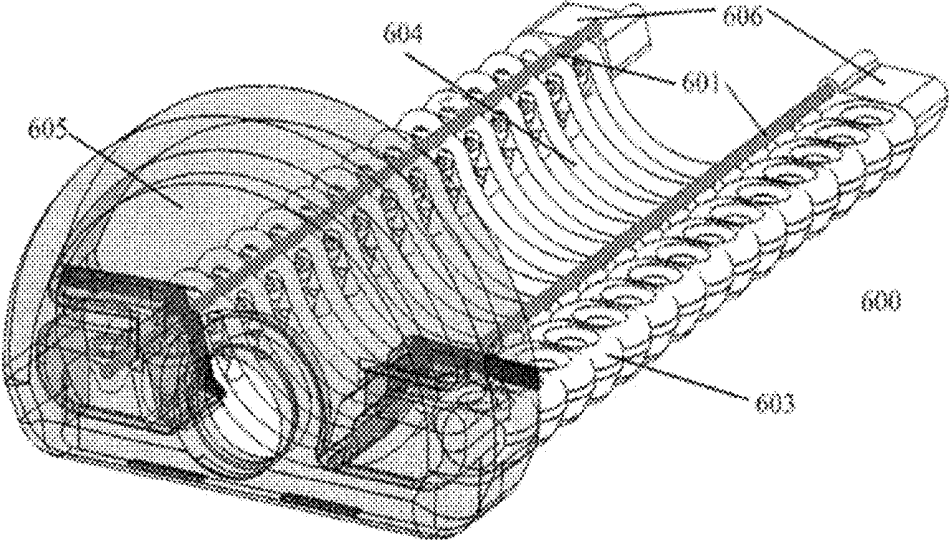

FIG. 6A

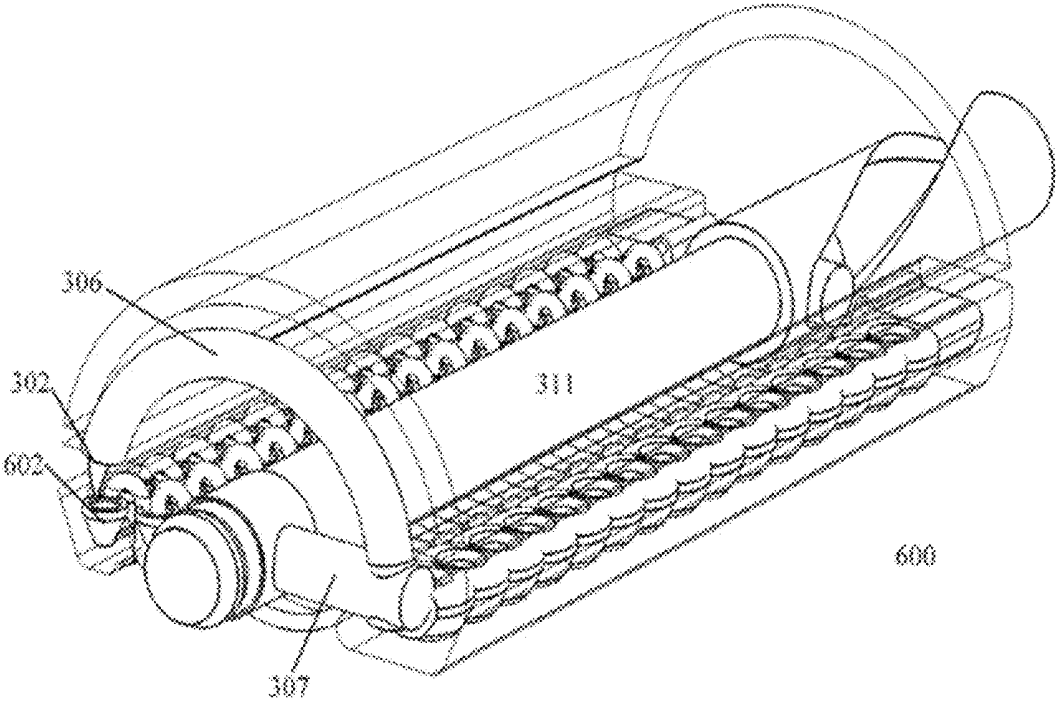

FIG. 6B

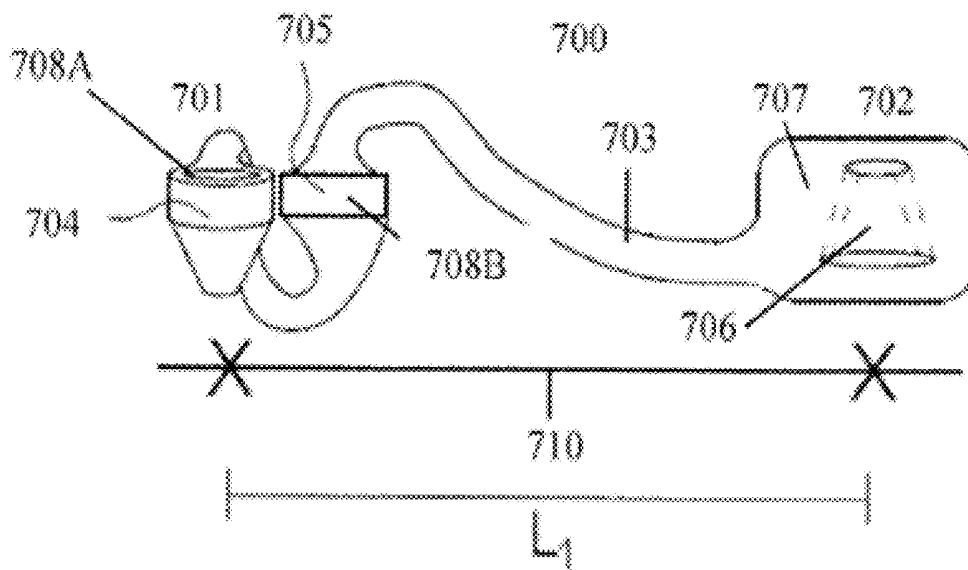

FIG. 7A

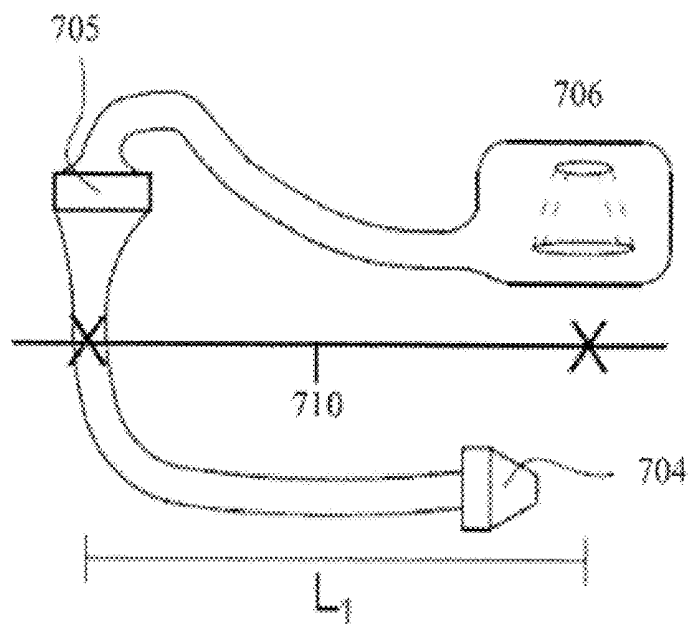

FIG. 7B

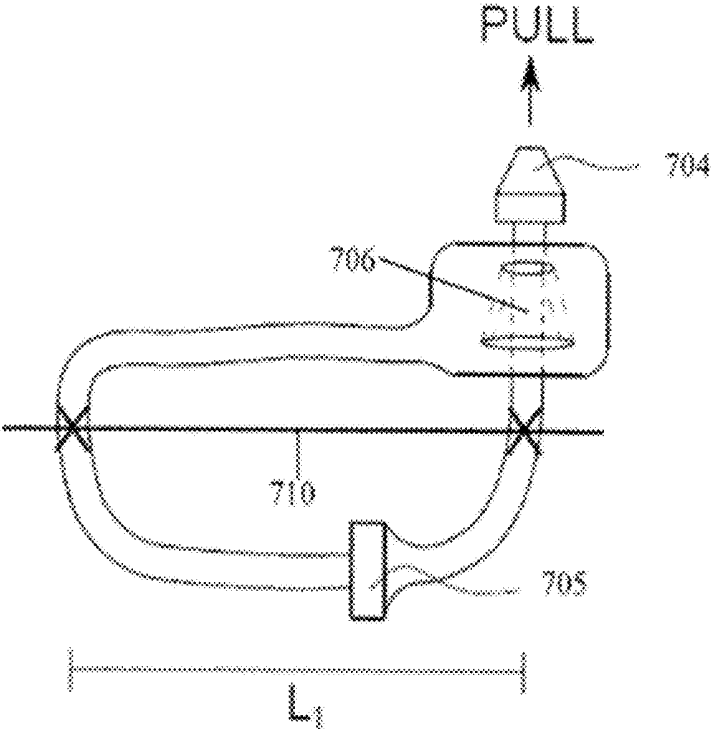

FIG. 7C

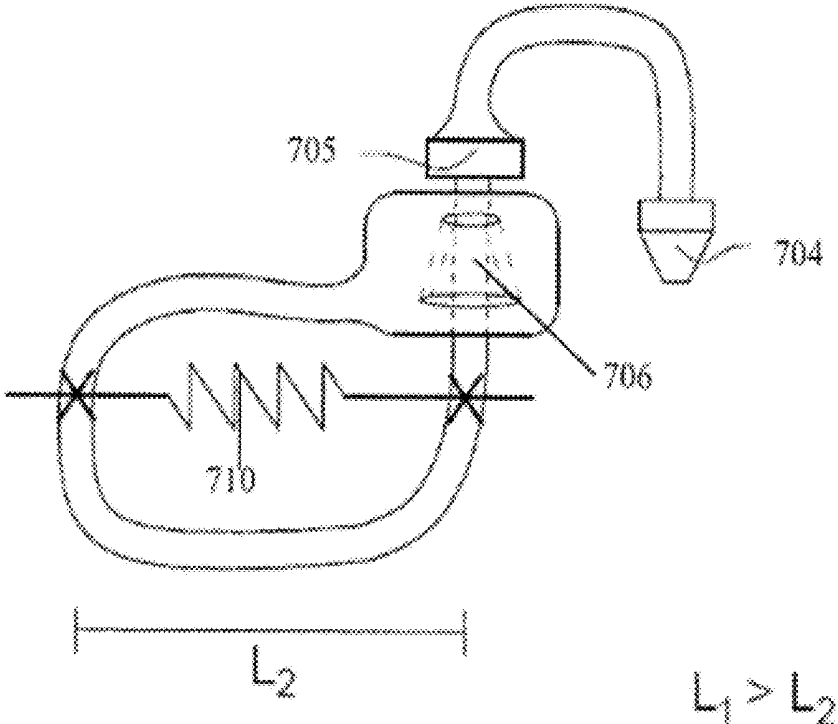

FIG. 7D

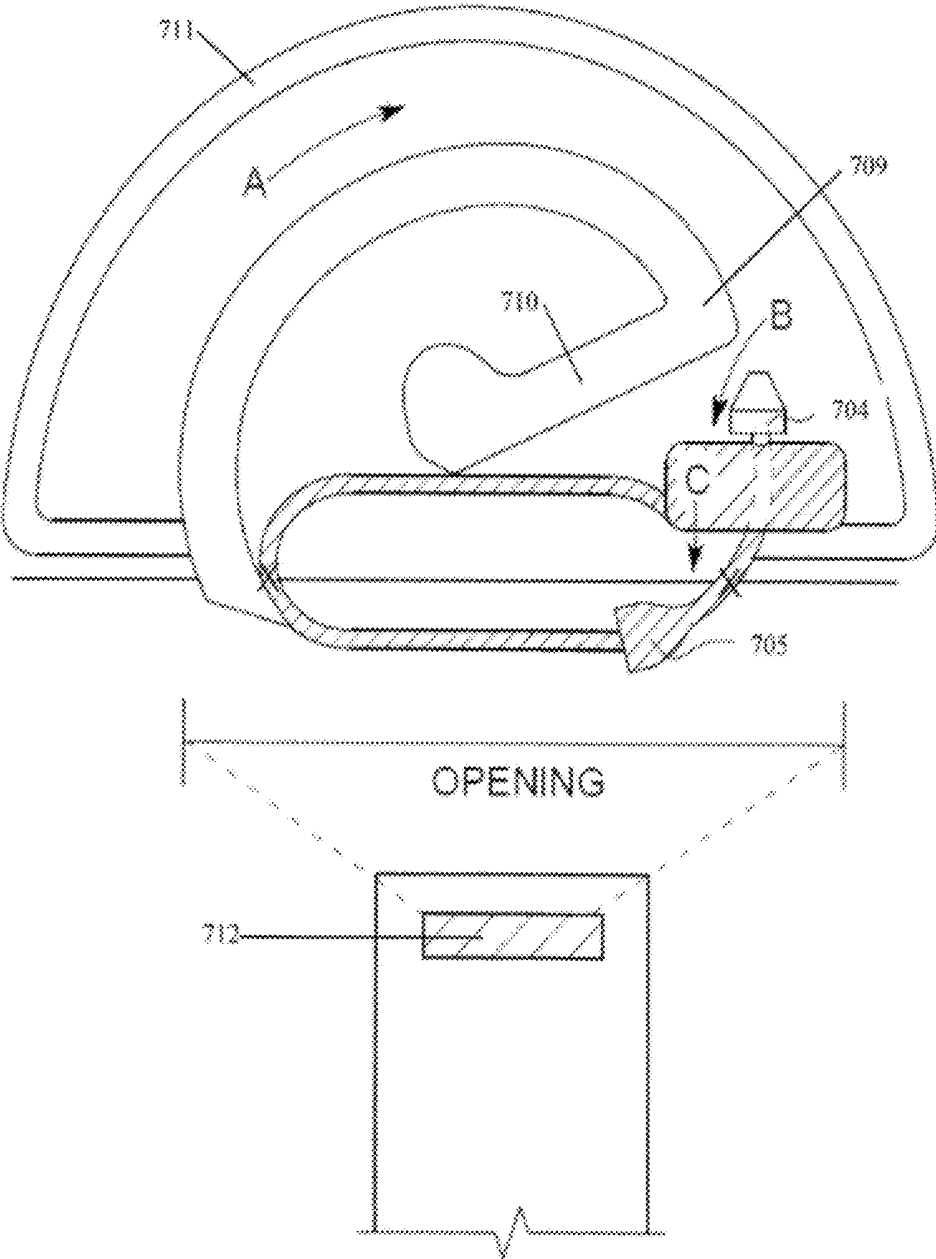

FIG. 8

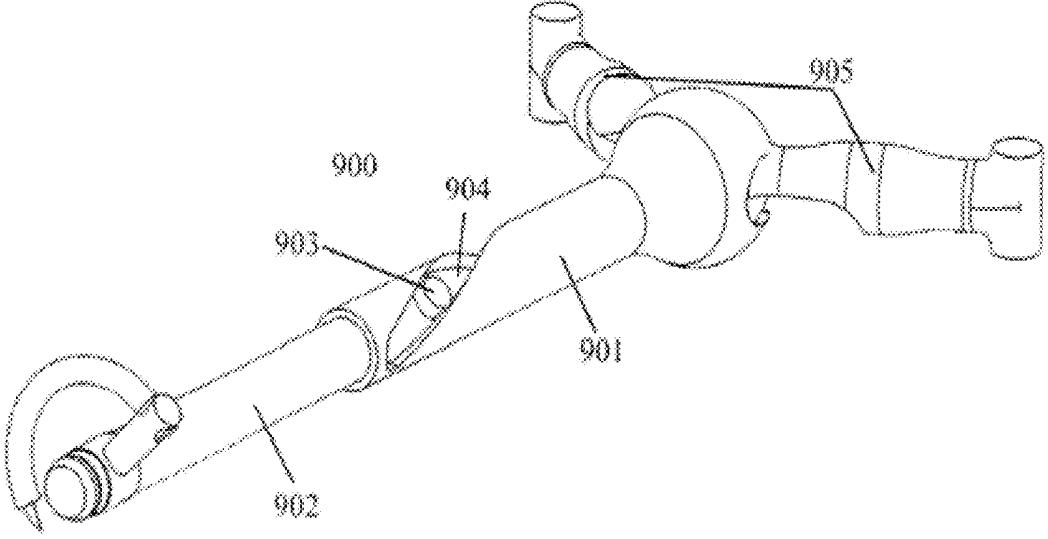

FIG. 9A

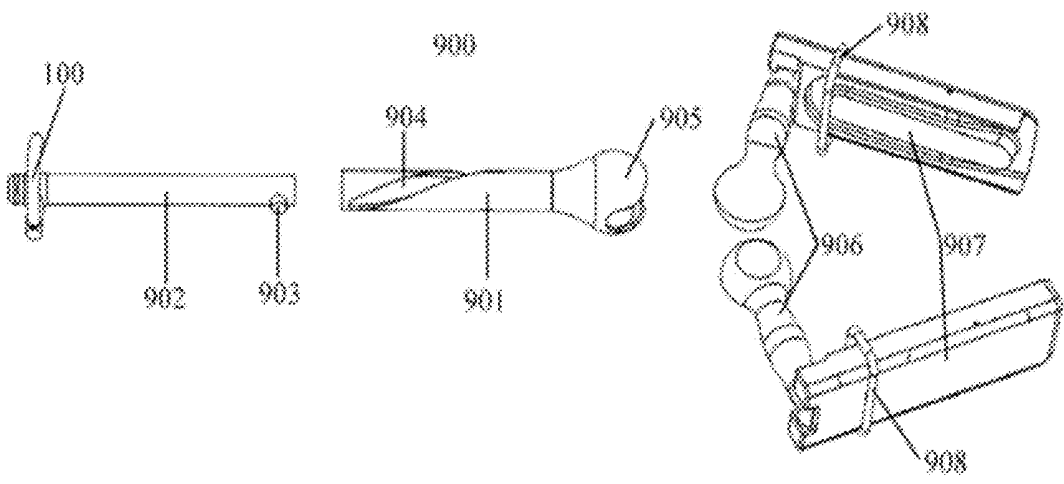

FIG. 9B

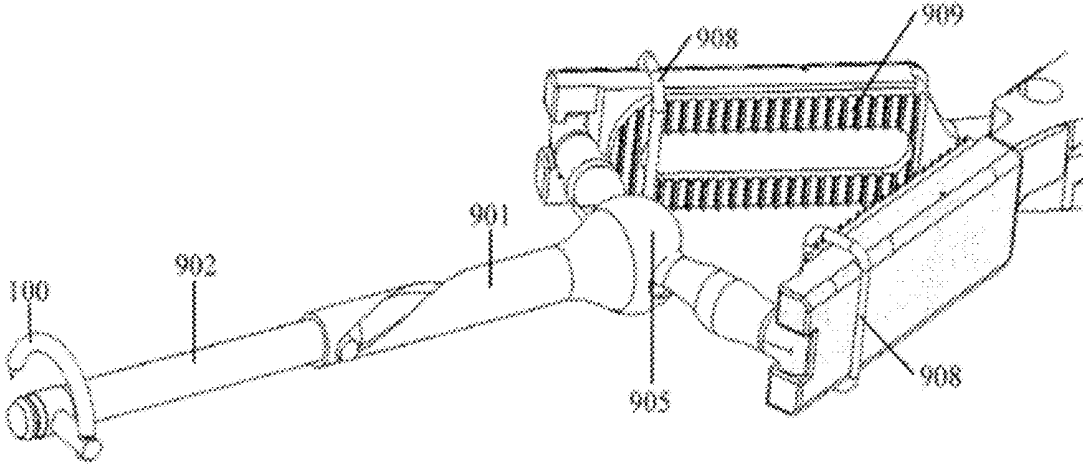

FIG. 9C

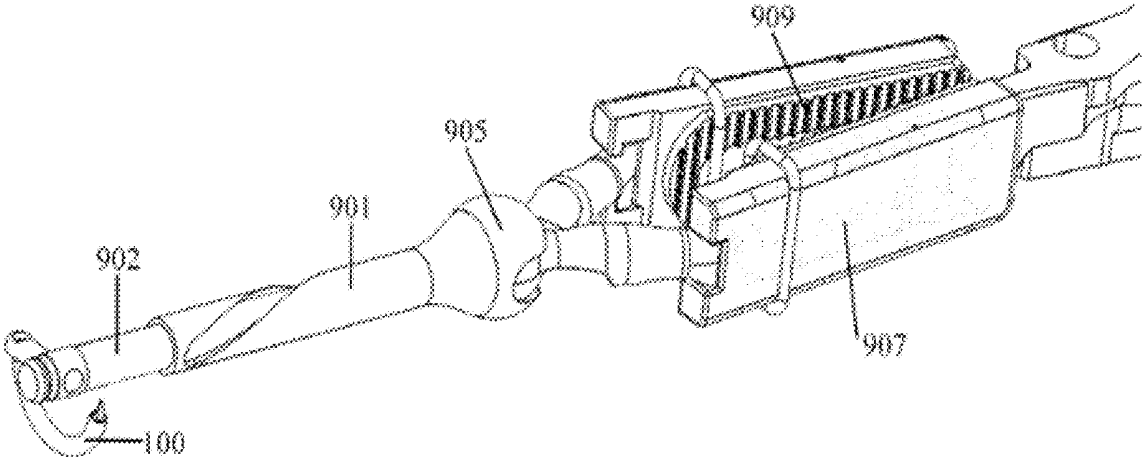

FIG. 9D

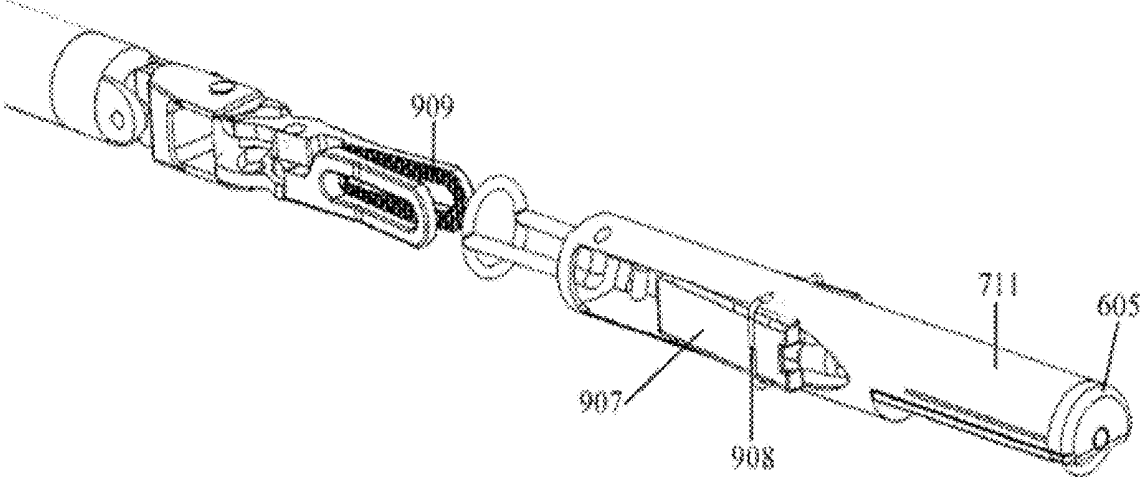

FIG. 9E

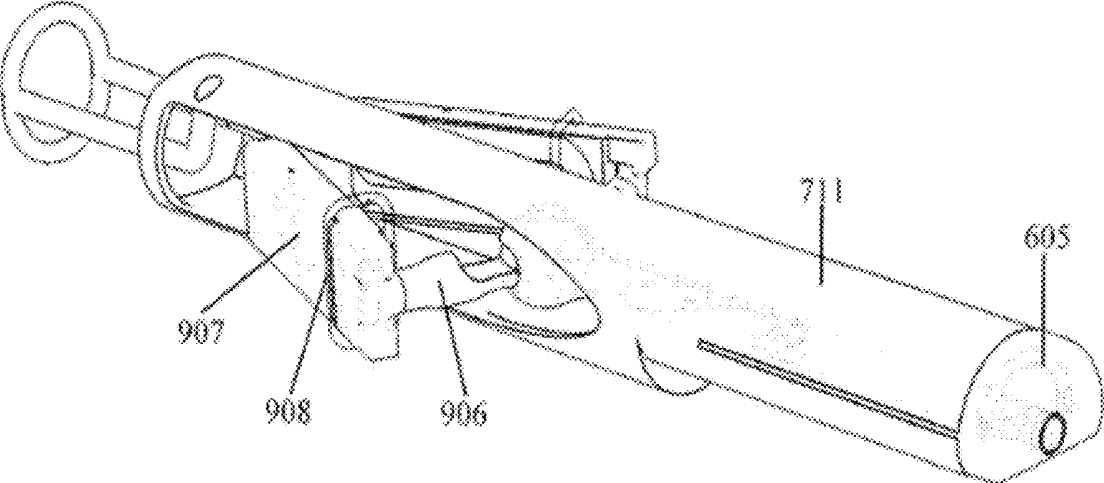

FIG. 9F

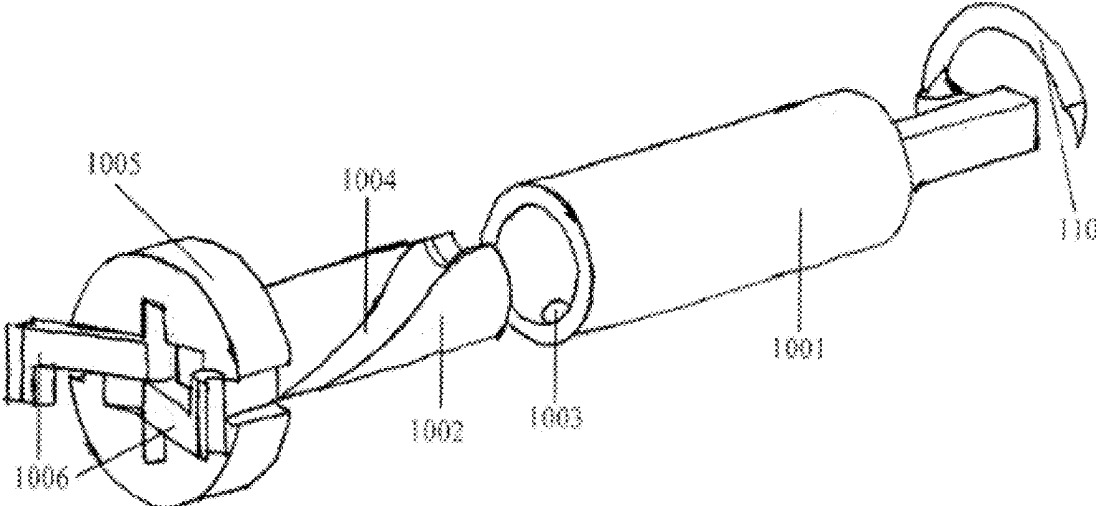

FIG. 10

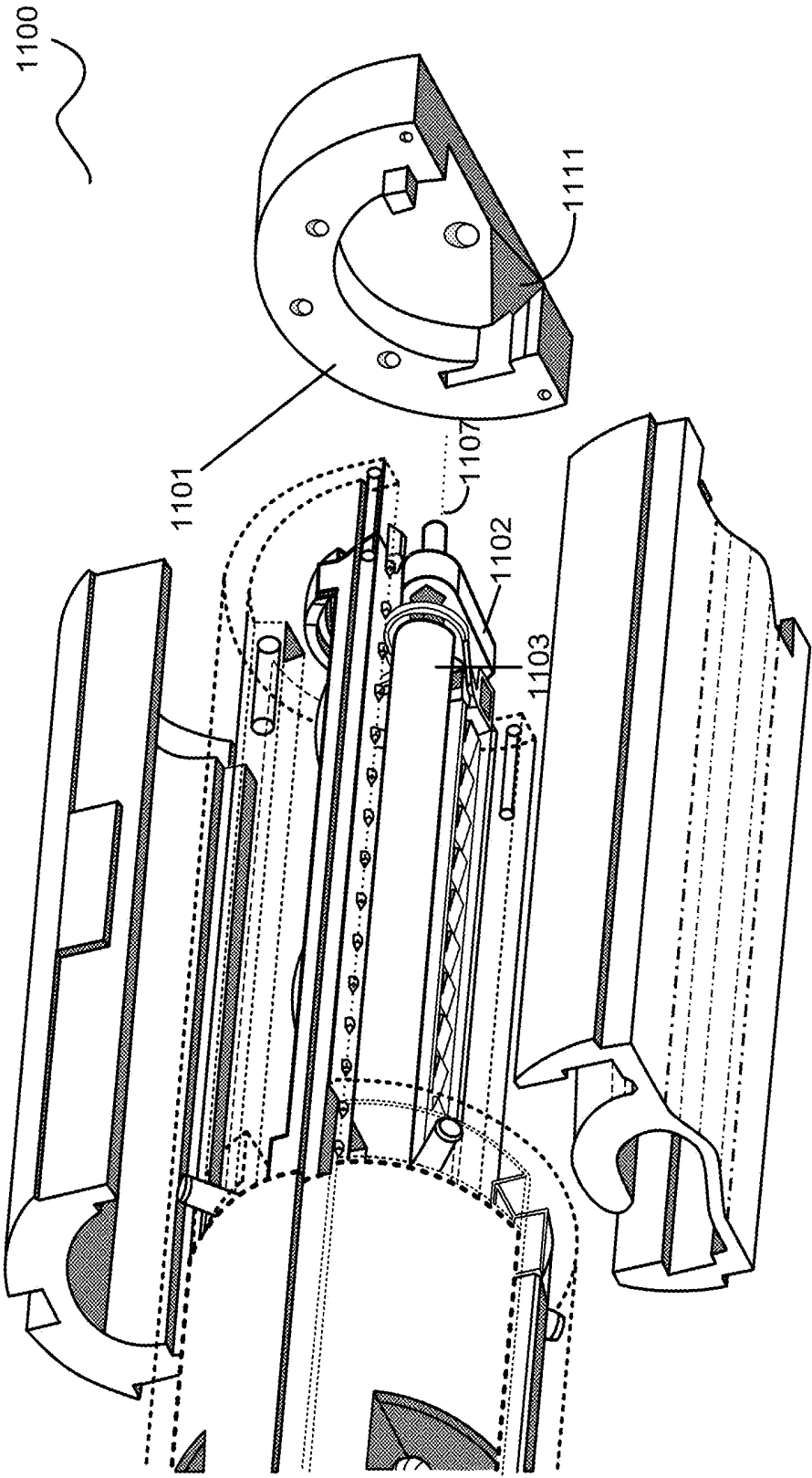

FIG. 11A

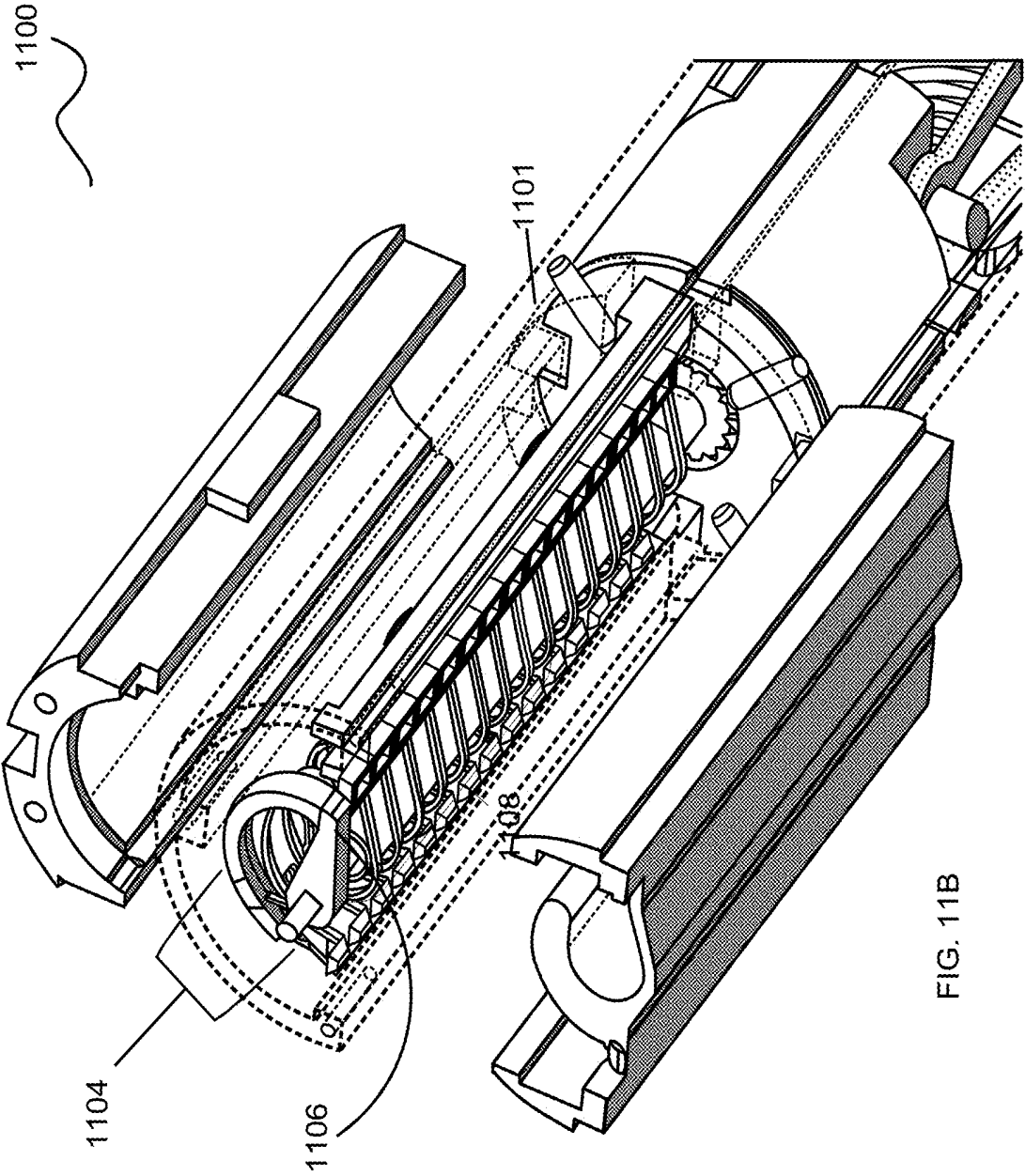

FIG. 11B

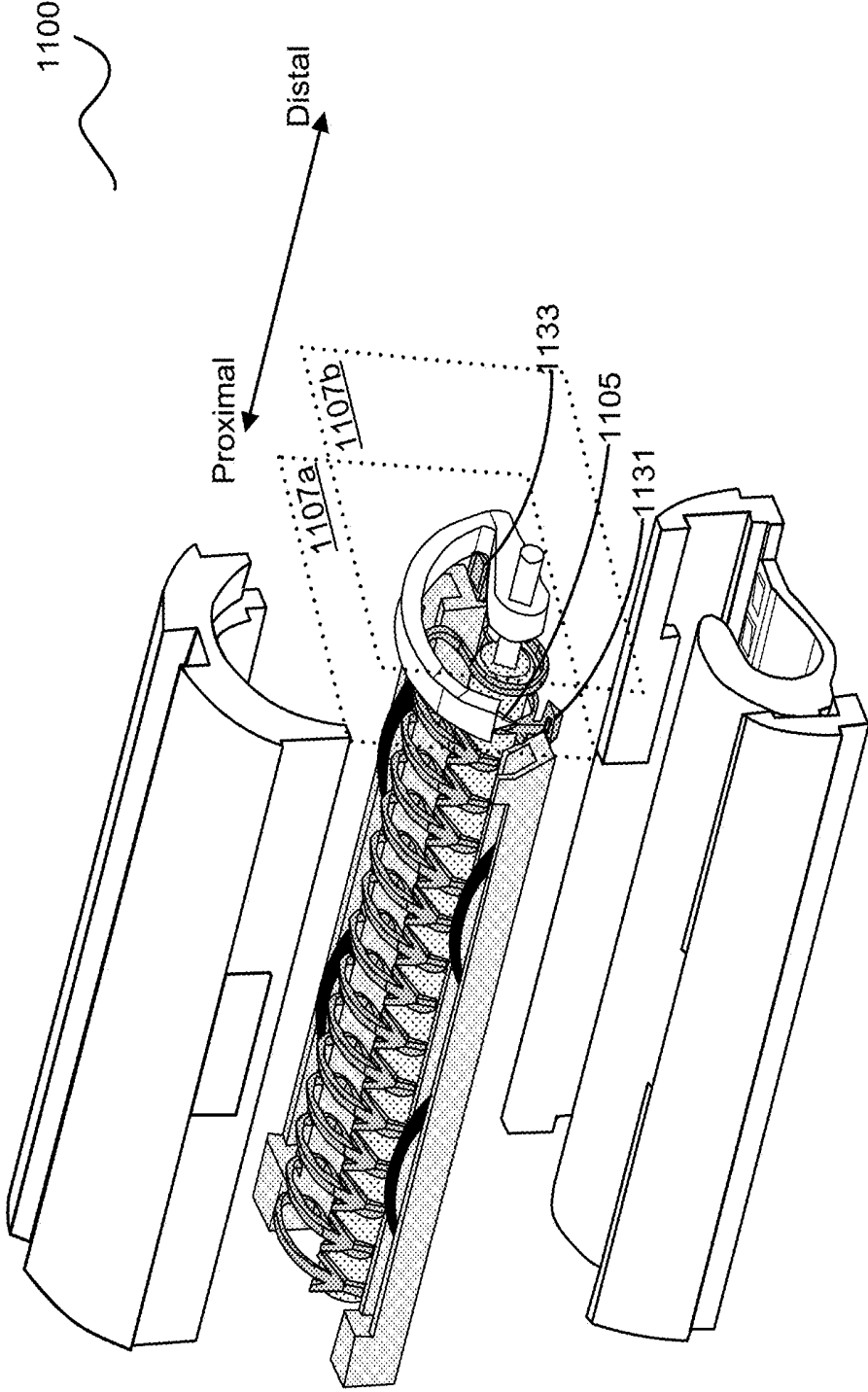

FIG. 11C

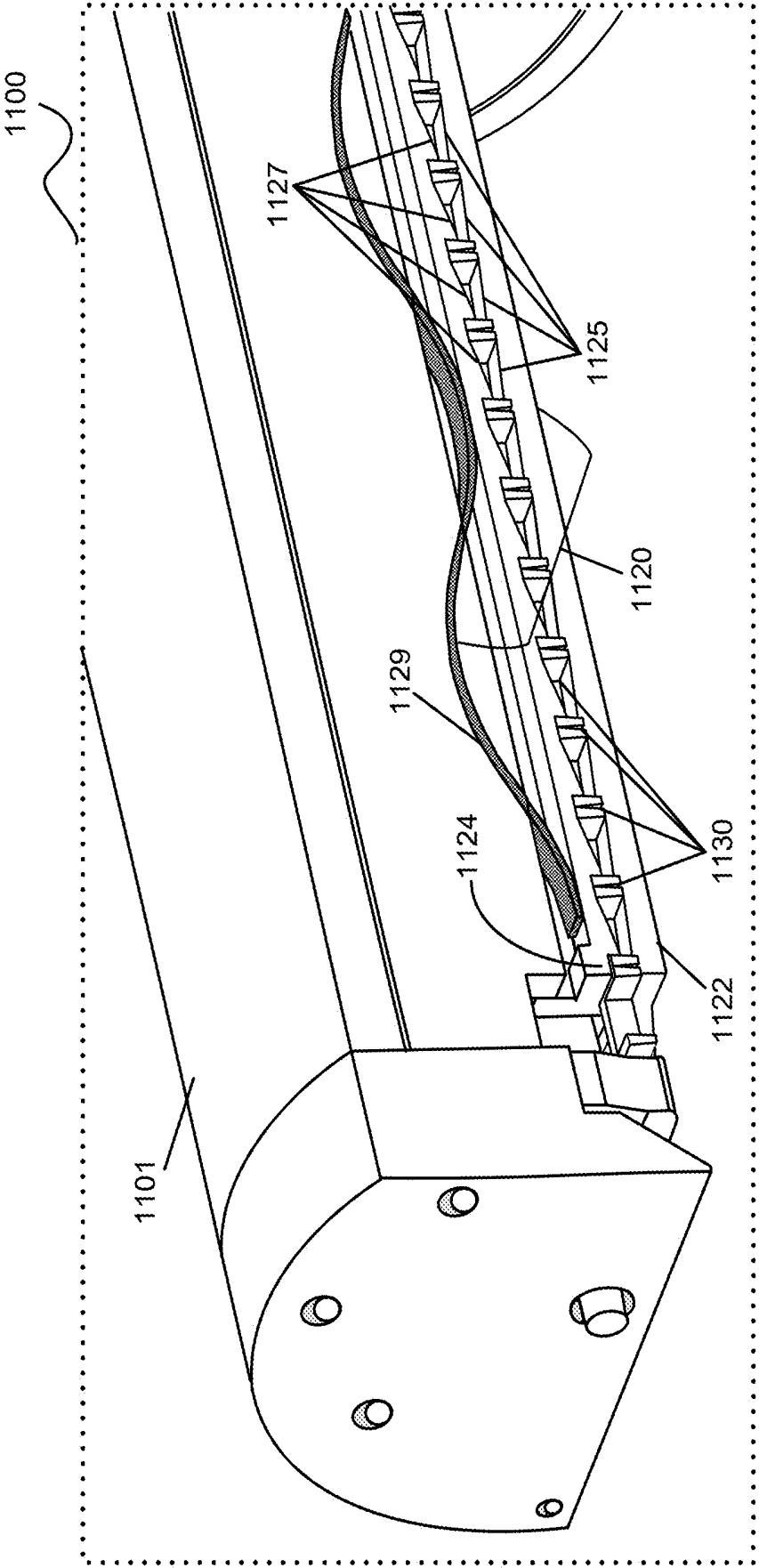

FIG. 11D

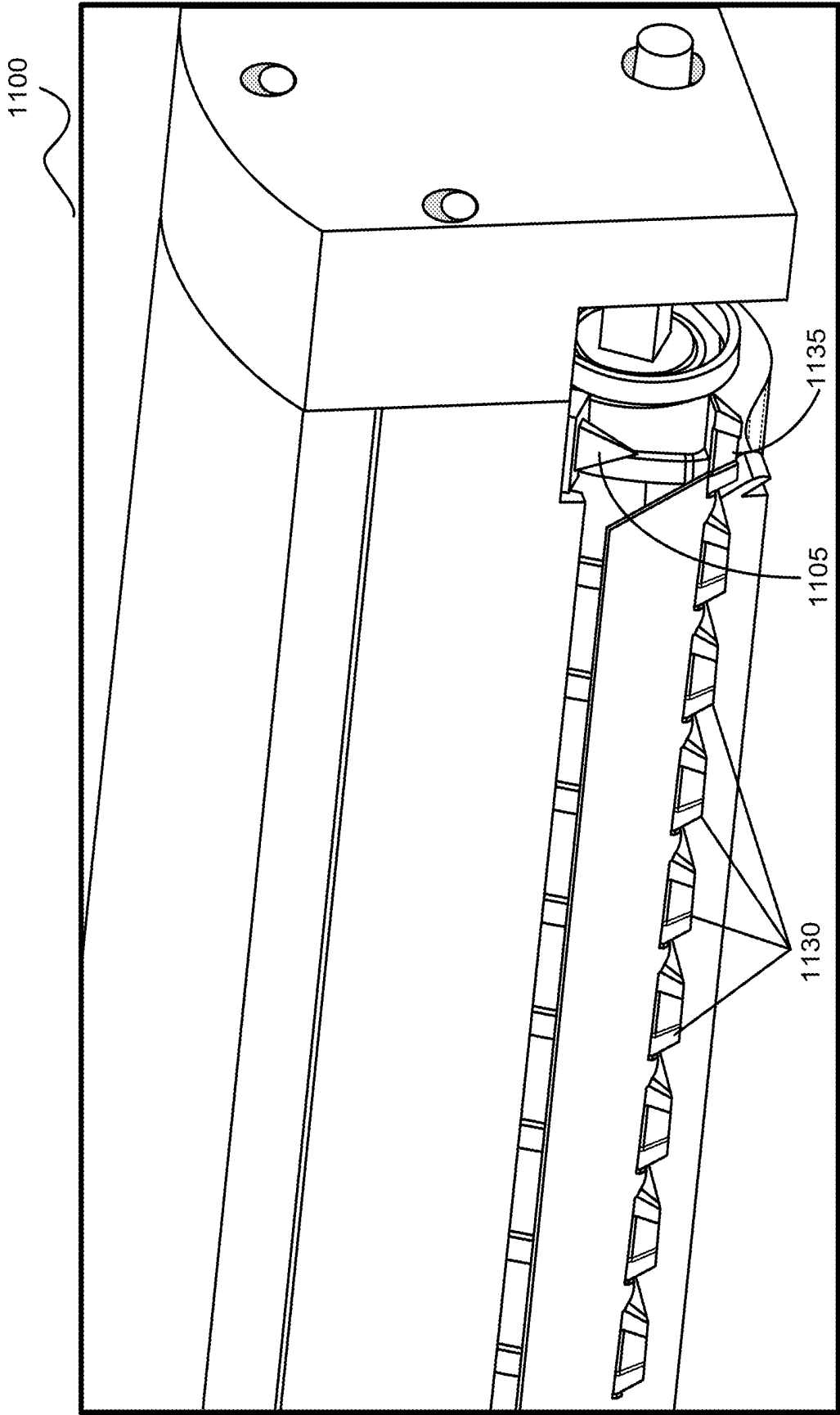

FIG. 11E

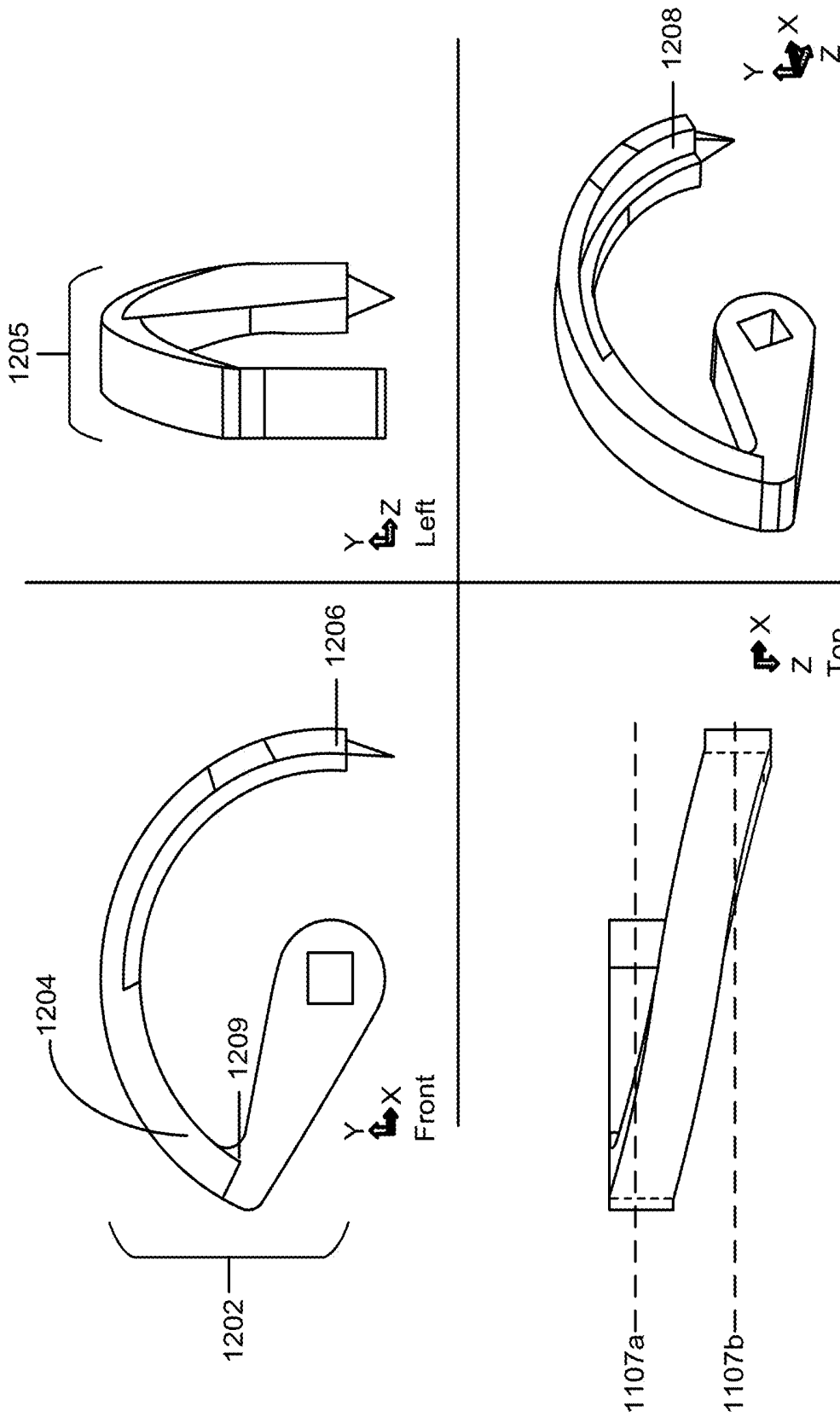
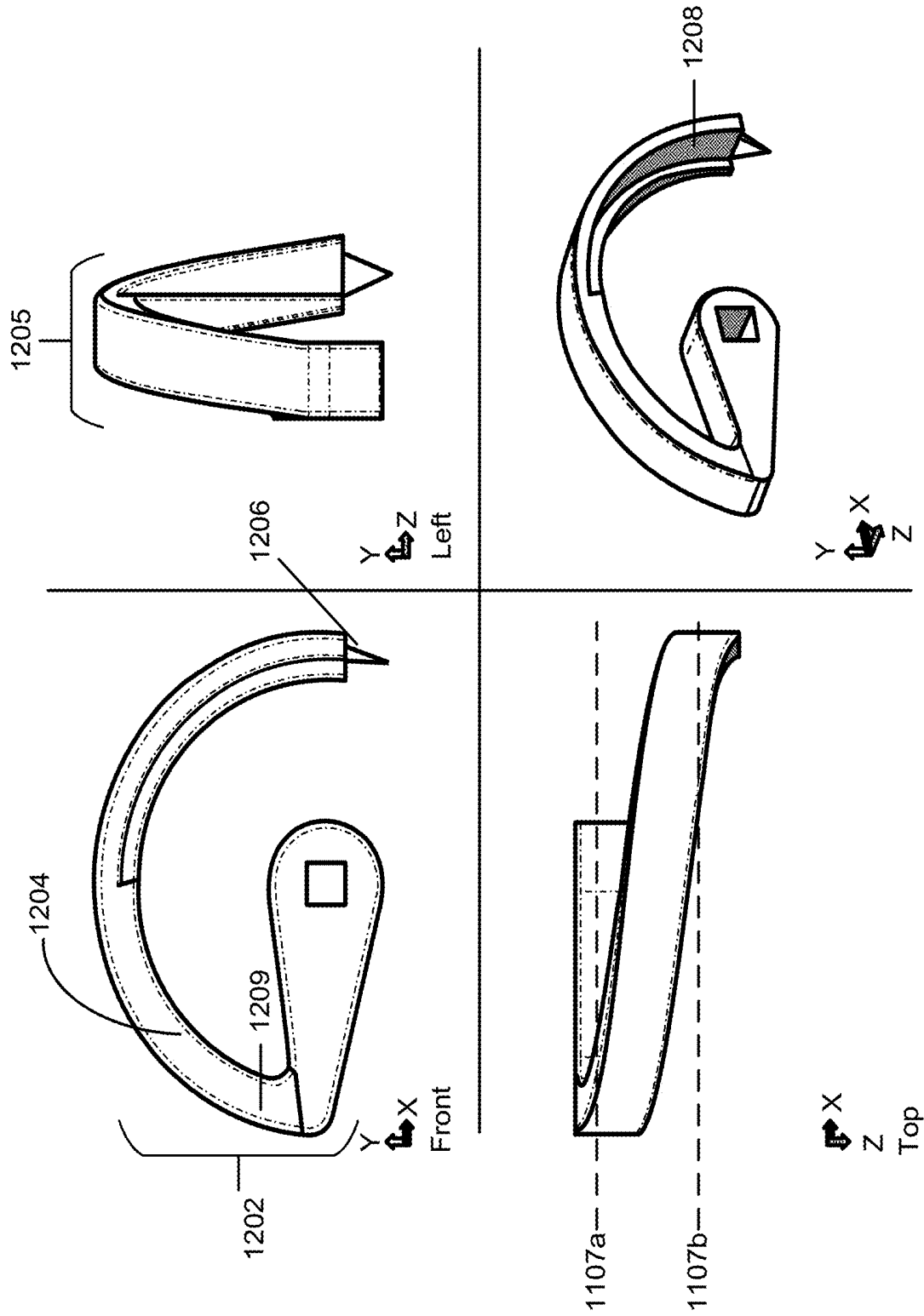

FIG. 12A



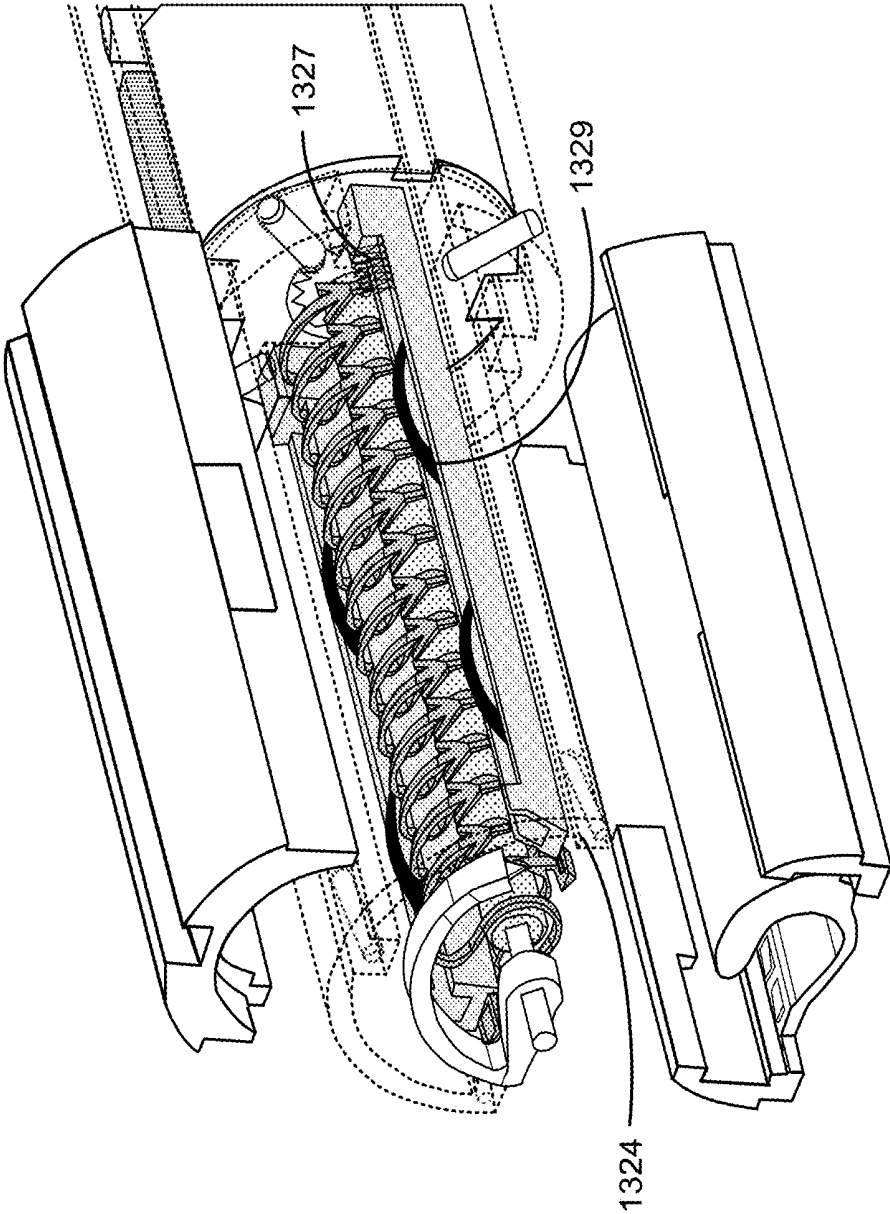

FIG. 13

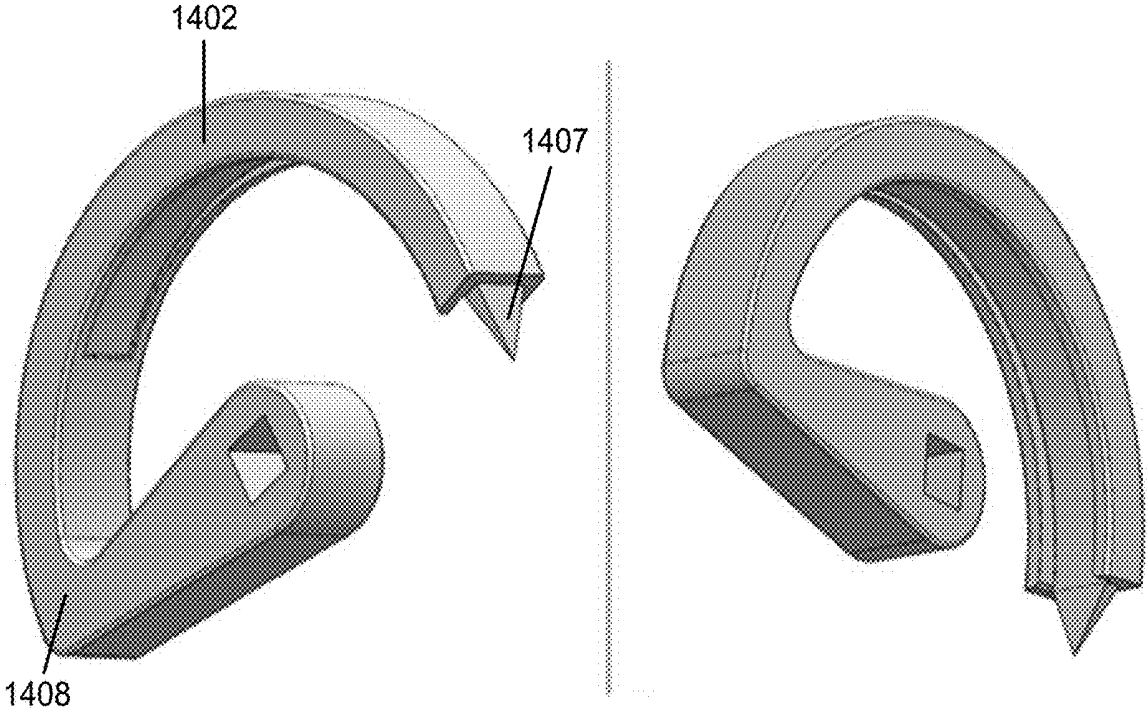

FIG. 14

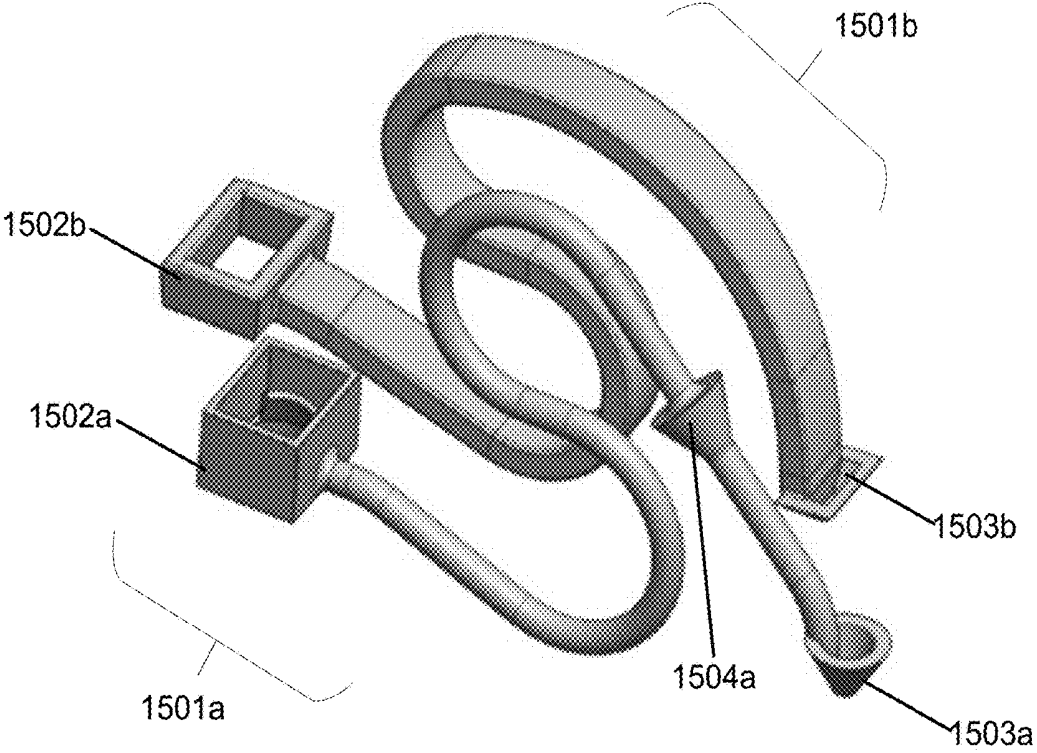

FIG. 15A

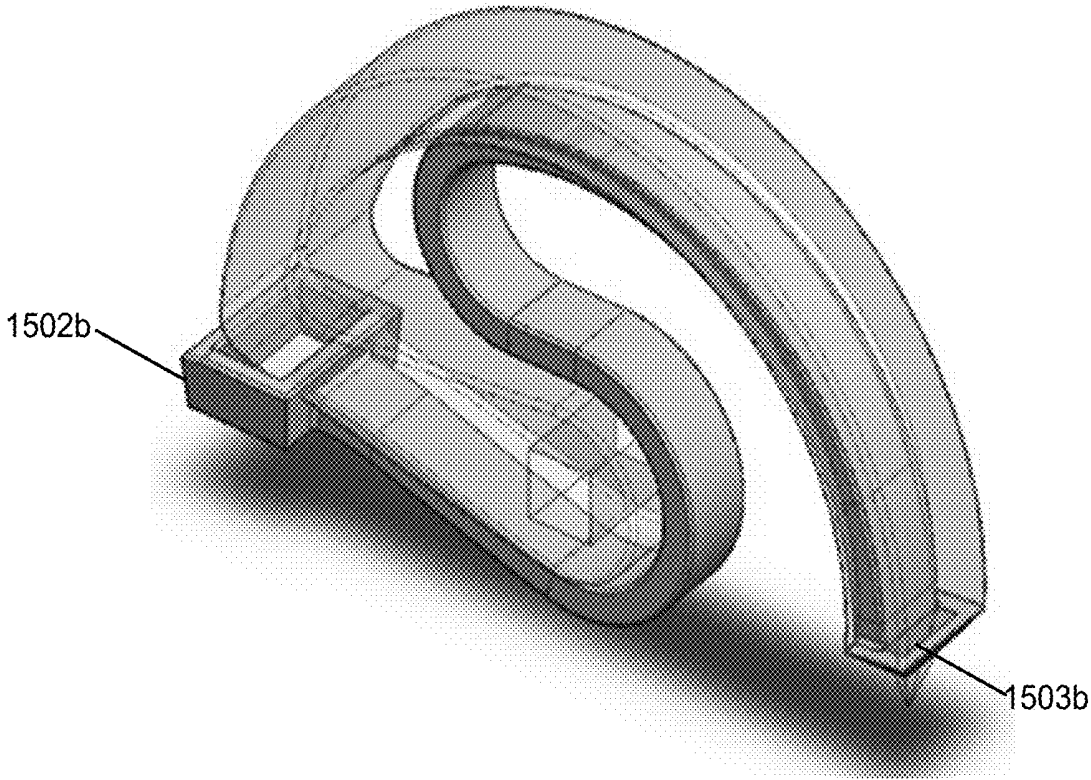

FIG. 15B

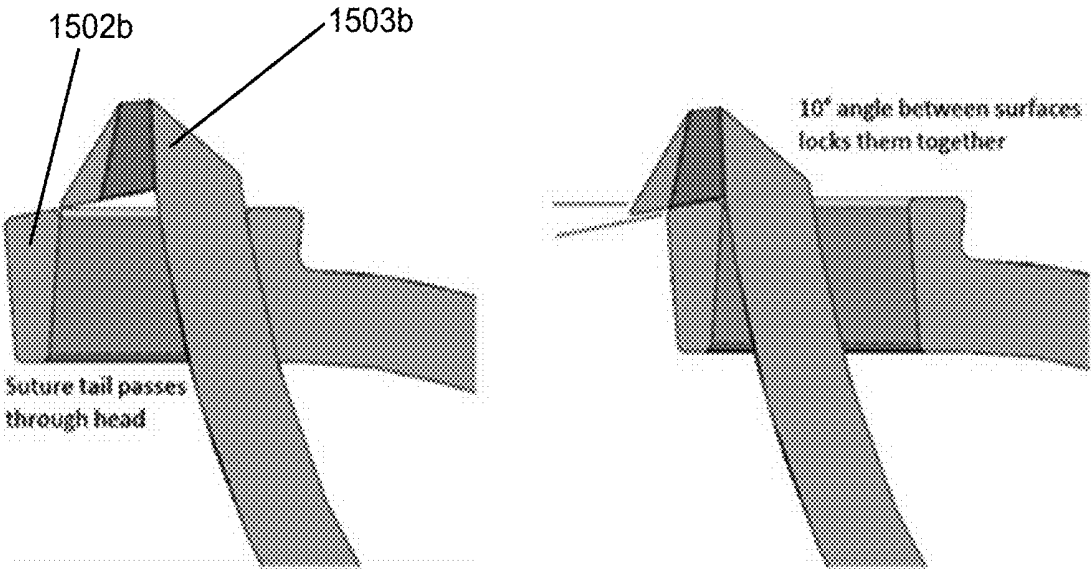

FIG. 15C

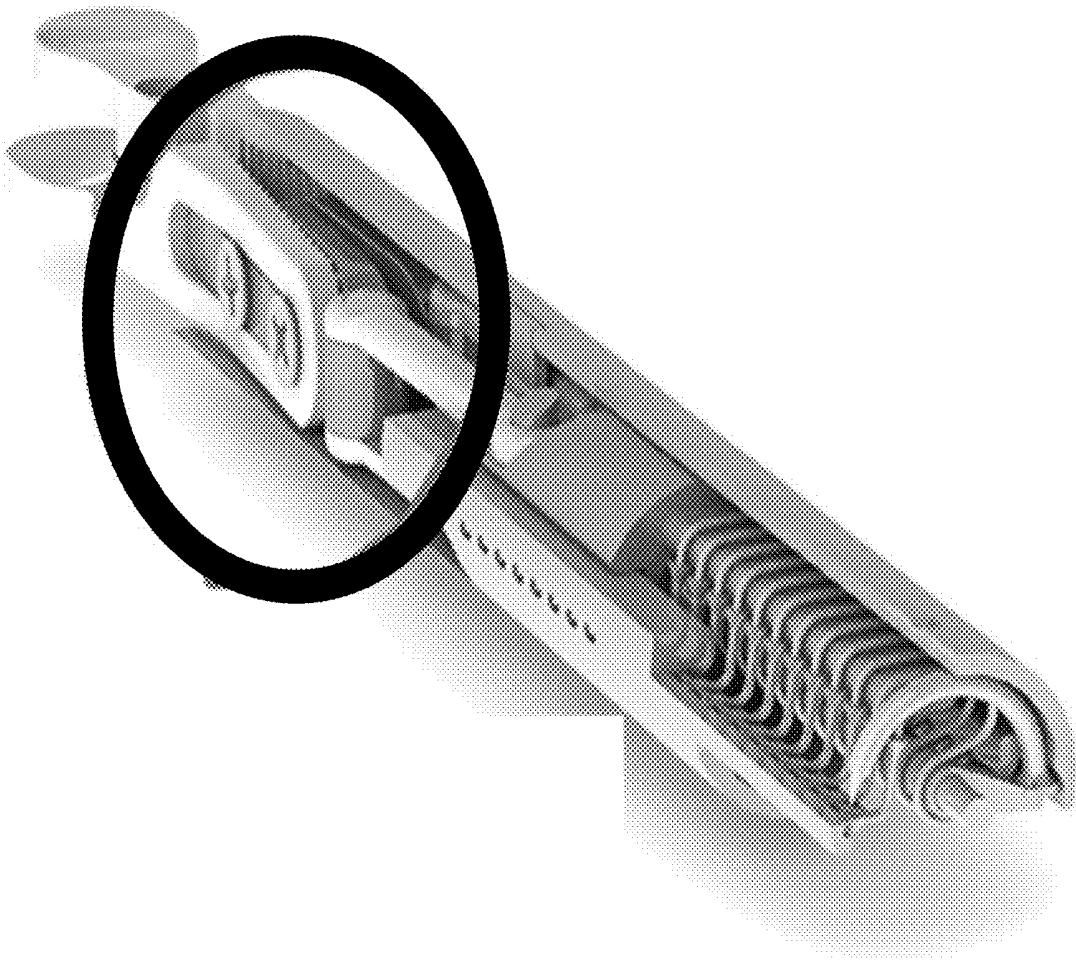

FIG. 16

LAPAROSCOPIC SUTURING DEVICES, NEEDLES, SUTURES, AND DRIVE SYSTEMS

CROSS REFERENCE TO RELATED APPLICATIONS

[0001] This application is a continuation-in-part of U.S. application Ser. No. 16/439,488, filed on Jun. 12, 2019, which is a continuation of prior, co-pending U.S. application Ser. No. 15/792,749, filed on Oct. 24, 2017, which claims priority to U.S. Provisional Application No. 62/411,830, filed on Oct. 24, 2016, both of which are incorporated herein by reference in their entirety for all purposes.

BACKGROUND

[0002] Laparoscopic surgical procedures are becoming increasingly common as an alternative to open surgical procedures. Pain, hemorrhaging, and recovery time may be reduced when performing a laparoscopic surgical procedure versus an open surgical procedure. However, laparoscopic procedures can take longer to perform, which can increase the cost of performing the laparoscopic procedure and limit the amount of laparoscopic procedures that can be performed daily.

[0003] Suturing is a common method employed in surgeries to close tissue openings and secure synthetic objects to tissue, among other things. The suturing process is more challenging when being used in laparoscopic surgical procedures as there is a smaller space to work within and the degrees of movement that a surgeon is afforded is restricted as compared to open surgical procedures. Given the benefits of laparoscopic procedures and other procedures with reduced invasiveness, technologies for improving access and facilitating efficient, reliable, and robust mechanisms for suturing can improve treatment and recovery outcomes for patients.

BRIEF SUMMARY

[0004] The following summary is provided to introduce a selection of concepts in a simplified form that are further described below in the detailed description. This summary is not intended to identify key features or essential features of the claimed subject matter, nor is it intended to be used to limit the scope of the claimed subject matter.

[0005] A suturing needle is provided that has a shaft forming a rod axis, a curved body having a piercing tip at one end and a base at another end; and an arm extending radially from the shaft to the base of the curved body such that the curved body is positioned in a plane orthogonal to the rod axis of the shaft and rotatable about the shaft in the plane orthogonal to the rod axis.

[0006] A suturing device incorporating the above described suturing needle can include one or more sutures, and a drive system. The drive system is coupled to the shaft and configured to actuate the rotation of the suturing needle in a first direction into tissue and a second direction that is opposite the first direction. The one or more sutures each include a fastener end, an anchor end, and a suture thread extending between the fastener end and the anchor end. A suture magazine can be used to hold the one or more sutures. The suturing needle and the suture magazine are positioned within a housing that allows for the suturing needle to exit

the housing, catching the suture at the fastener end, as the suturing needle rotates in the first direction in the plane orthogonal to the rod axis.

[0007] A drive system for a suturing device can include a tube having a proximal end that may abut a hub that couples to a manual or robotic arm, a distal end that couples to a shaft of a suturing needle, and a rod having the hub at its distal end and one or more protrusions on the rod in a position towards the proximal end of the rod and one or more grooves, each groove being for a corresponding one of the one protrusions, the one or more grooves extending in a spiral manner from a proximal end of the tube towards the distal end of the tube. The one or more protrusions on the rod are configured to move along the one or more grooves of the tube. The rod is configured to remain fixed along a direction of a tube axis of the shaft while being able to rotate about the tube axis. The tube is configured to remain fixed in a radial direction while being moveable forward and backward along the tube axis, the moving of the tube in the forward and backward direction causing the one or more protrusions of the rod to move along the one or more grooves and thereby rotate the rod and the shaft that would be coupled thereto about the tube axis. In another implementation, the protrusions may be in the tube and the grooves on the rod.

[0008] The invention(s) also relate a system for advancing a set of sutures forward after each suture is placed at a repair site (e.g., tissue associated with a laparoscopic procedure or other procedure). In embodiments, the system includes a ratcheting mechanism that includes one or more tracks for retaining and/or supporting a set of sutures in operation modes associated with suture advancement (and in baseline operation modes without suture advancements, and for advancing remaining sutures forward. In an embodiment, the system includes a first track (i.e., suture positioning track) for retaining a set of sutures at a first side within a suture magazine, and second track (i.e., suture moving track) for supporting the set of sutures at a second side and facilitating forward advancement of sutures as leading sutures are used. In one or more of these embodiments, the second track moves relative to the first track as sutures are placed, thereby advancing remaining sutures forward (e.g., as leading sutures are used or otherwise displaced from the system). In an embodiment, the second track is coupled to one or more biasing elements (e.g., linear springs, non-linear springs, wave springs, etc.) that facilitate lifting and/or forward advancement of remaining sutures in the suture positioning tray as each leading suture is placed. The biasing element(s) may have asymmetric configurations in relation to bilateral sides of the suture moving tray, in order to provide delayed timing of advancement associated with different sides of the suture moving tray.

[0009] In particular, embodiments of the invention(s) can include needle features that increase range of delivery rotation of the needle into a tissue or other repair site.

[0010] Additionally or alternatively, embodiments of the invention(s) can include suture magazine components providing compact and reliable mechanisms for advancing sutures of a set of sutures toward a deployment position. Such components and configurations can provide improvements over mechanisms that tend to apply high deployment force when all sutures are loaded, with decreased deployment force as sutures are deployed. Such embodiments can implement "lost-motion" designs that allow ratcheting components of the mechanisms to travel only as far as needed

between instances of suture deployment in a consistent manner appropriate to the suture capacity of the suture magazine.

[0011] These and other features and advantages will be apparent from a reading of the following detail description, and a review of the appended drawings. It is to be understood that the foregoing summary, the following detail descriptions, and the appended drawings are only explanatory and are not restrictive of various aspects claimed.

BRIEF DESCRIPTION OF DRAWINGS

[0012] FIG. 1A shows a suturing needle in accordance with an implementation of the invention.

[0013] FIG. 1B shows an alternative suturing needle in accordance with an implementation of the invention.

[0014] FIG. 1C shows a cross sectional view of a suturing device in a start position in accordance with an implementation of the invention.

[0015] FIG. 2A shows a suture in accordance with an implementation of the invention.

[0016] FIGS. 2B-2C show side views of a fastener end according to an implementation of the invention.

[0017] FIGS. 3A-3E show views of a suturing device and housing in accordance with an implementation of the invention. FIG. 3A shows a view of a suturing device over tissue in a middle position; FIG. 3B shows a view of a suturing device over tissue in an end position; FIG. 3C shows a cross-sectional view of a suturing device over tissue in an end position; FIG. 3D shows a view of a suture housing that is filled with sutures; FIG. 3E shows a view of an empty suture housing.

[0018] FIG. 4 shows a suturing device including a trigger according to an implementation of the invention.

[0019] FIGS. 5A-5B show bottom views of a suturing device with sutures in accordance with an implementation of the invention.

[0020] FIG. 6A shows a suture magazine and its various components, including a needle housing, in accordance with an implementation of the invention.

[0021] FIG. 6B shows a suture magazine positioned inside the housing of a suturing device according to an implementation of the invention.

[0022] FIGS. 7A-7D shows an automatic suture tightening technique in accordance with an implementation of the invention.

[0023] FIG. 8 shows a manual suture tightening technique in accordance with an implementation of the invention.

[0024] FIG. 9A shows a side view of a drive system in accordance with an implementation of the invention.

[0025] FIG. 9B shows a side view of an exploded view of a drive system in accordance with an implementation of the invention.

[0026] FIGS. 9C-9D show a view of a drive system attached to handles in the open and closed positions in accordance with an implementation of the invention.

[0027] FIG. 9E shows the grasping clamp and the suturing device apart and in the end position.

[0028] FIG. 9F shows the suturing device in the start position.

[0029] FIG. 10 shows a side view of an alternative drive system in accordance with an implementation of the invention.

[0030] FIG. 11A depicts a first exploded view of a system for suturing, in accordance with one or more embodiments.

[0031] FIG. 11B depicts a second exploded view of a system for suturing, in accordance with one or more embodiments.

[0032] FIG. 11C depicts a third exploded view of a system for suturing, in accordance with one or more embodiments.

[0033] FIG. 11D depicts a first cross sectional view of a system for suturing, the system including suture advancing components, in accordance with one or more embodiments.

[0034] FIG. 11E depicts a second cross sectional view of a system for suturing, the system including suture advancing components, in accordance with one or more embodiments.

[0035] FIG. 12A depicts a first needle component of a system for suturing, in accordance with one or more embodiments.

[0036] FIG. 12B depicts a second needle component of a system for suturing, in accordance with one or more embodiments.

[0037] FIG. 13 depicts an exploded view of an embodiment of a suture magazine, in accordance with one or more embodiments of a suturing system.

[0038] FIG. 14 depicts multiple views of a suturing needle for placing sutures, in accordance with one or more embodiments of a suturing system.

[0039] FIG. 15A depicts embodiments of a suture, in accordance with one or more embodiments of a suturing system.

[0040] FIG. 15B depicts an embodiment of a suturing needle interaction with a suture, in accordance with one or more embodiments of a suturing system.

[0041] FIG. 15C depicts operation of an embodiment of a suture, in accordance with one or more embodiments of a suturing system.

[0042] FIG. 16 depicts an embodiment of an attachment for control of an embodiment of a suturing system.

[0043] The figures depict various embodiments for purposes of illustration only. One skilled in the art will readily recognize from the following discussion that alternative embodiments of the structures and methods illustrated herein may be employed without departing from the principles described herein.

DETAILED DESCRIPTION

1. Introduction

[0044] Implementations of the invention provide devices to improve suturing techniques in laparoscopic surgical procedures. Certain implementations of the invention enable surgeons to perform suturing procedures more efficiently even with the challenges presented by the restricted movement inherent in laparoscopic procedures.

[0045] Laparoscopic procedures can be performed manually or with a robotic-assisted surgical system. Manual laparoscopic surgical procedures involve cutting small incisions into the patient and placing tubes called ports through the incision site. The ports can include surgical instruments such as forceps, hooks, scissors, and more to mimic the movement and ability of the surgeon's hands. This allows the surgeon to perform the entire surgery ex vivo without physically placing their hands into the patient's body.

[0046] Alternatively, robotic-assisted laparoscopic procedures use a robotic-assisted surgical system that generally includes three or four robotic arms that the surgeon can manipulate from a distance at a console. Similar to the ports used in manual laparoscopic surgical procedures, at the

console, the surgeon operates haptic controls that mimic the movement and ability of the surgeon's hands. With both manual laparoscopic procedures and robotic-assisted laparoscopic procedures, the surgeon must use instruments rather than their own hands to interact with tissue, making it difficult to reproduce functions that would normally be performed with a human hand. As a result, applying sutures to tissue during laparoscopic surgical procedures have become more cumbersome and tedious resulting in longer surgery times.

[0047] In particular, laparoscopic sacrocolpopexy, a surgical procedure used to treat vaginal vault or uterine prolapse, is susceptible to the challenges that current laparoscopic procedures present. A uterine prolapse results when the uterus descends from its normal position within the pelvis. Every year in the United States, approximately 300,000 women participate in pelvic organ prolapse corrective surgery. Sacrocolpopexy is a surgical technique that aims to reduce prolapse and restore the anatomy and function of the vagina by suturing a synthetic mesh to the vaginal wall. The mesh provides the vagina with support and requires about 12-15 sutures. Overall, the procedure can take three to four hours to complete, where the suturing process alone may require 60 to 100 minutes.

[0048] In order to address these challenges, certain implementations provide an efficient suturing device that, with a single motion, can stitch and tighten a suture, which diminishes the time, cost, and difficulty of laparoscopic surgeries.

[0049] Certain implementations involve automated stitching and tightening of sutures.

[0050] As used herein, the term "distal" end generally refers to the end that is further from the surgeon when the surgeon is operating the device.

[0051] Additionally, the term "proximal" end generally refers to the end that is closer to the surgeon when the surgeon is operating the device.

2. System Embodiments

[0052] FIGS. 1A-1C depict a suturing needle 100 that can be used in a suturing device in accordance with one or more embodiments (explained, for instance, in further detail below with respect to FIGS. 3A-3E). The suturing needle 100 has a curved body 101, an arm 102, and a shaft 103. The curved body 101 may have a piercing tip 104 at one end and a base 106 at the other end. The shaft 103 can form a rod axis 107. In one implementation, the suturing needle 100 may have a needle grasping edge 105 that is formed by the tube of the curved body 101 having a larger diameter than the base of the piercing tip 104. This allows the suture to be held along the needle grasping edge 105 as the curved body 101 rotates about the shaft 103. In an alternate implementation, the suturing needle 100 may also have a grasping element 112 that is configured to form a recess between the grasping element 112 and the piercing tip 111 so that a suture may be held in the recess as the curved body 101 rotates about the shaft 103. In another implementation, the needle may include a groove 113 extending from the piercing tip 104 along at least a portion of an outer surface of the curved body 101. The groove 113 can be configured to maintain a fastener portion of a suture in a position along the outer surface of the curved body 101 of the suturing needle 100.

[0053] As shown in FIGS. 1A-1C, the arm 102 extends radially from the shaft 103. The curved body 101 is positioned in a plane orthogonal to the rod axis 107 of the shaft

103 and rotatable about the shaft 103 in the plane orthogonal to the rod axis 107 to drive in to and out of a tissue 108 to apply a suture 200 (described in more detail below).

[0054] FIG. 2A depicts a suture 200 that may be used with a suturing device, in accordance with one or more embodiments (e.g., including embodiments described in more detail in Sections 2.1 and 2.2 below). The embodiment of the suture 200 and variations of the suture can include a fastener end 201, an anchor end 202, and a suture thread 203 connected to and extending between the fastener end 201 and the anchor end 202. The fastener end 201 and the anchor end 202 can be made of polydillactide (PDLLA) or another biodegradable material. The suture thread 203 may be made of biodegradable material such as polydioxanone (PDS), polypropylene, or the like.

[0055] The embodiment of the suture 200 and variations of the suture can include a first fastener mechanism 204 and a second fastener mechanism 205. Referring to FIG. 1 and FIGS. 2A-2C, as the suturing needle 100 rotates about the shaft 103, the piercing tip 104 is inserted through the first fastener mechanism 204. As the suturing needle 100 continues rotation, the needle grasping edge 105 secures the first fastener mechanism 204 and pulls it through the tissue 108 and through the chamber 206 of the anchor end 202 of the suture 200. The first fastener mechanism 204 can then be used to pull the second fastener mechanism 205 through the chamber 206 to tighten the suture 200 to pull the tissue 108 together.

[0056] In this embodiment, as the first fastener mechanism 204 is moved through the chamber 206 (see FIG. 2C) of anchor housing 207 of the anchor end 202, the geometrical configuration locks the fastener grasping edge 208A of the first fastener mechanism 204 on top of the chamber 206 such that the first fastener mechanism 204 cannot be moved backwards through the chamber 206.

[0057] Referring to FIG. 2A, the fastener end 201 has a top 209 and a bottom 210. The suture thread 203 may be embedded in, molded in, or otherwise fixed to the top 209 of the fastener end 201. The bottom of the fastener end 201 may include a suture guide loop that performs part of the function of the first fastener mechanism, meaning that the suture guide loop can be secured by the grasping element 112 or other functionally similar structure and moved through the tissue 108 and into or through the anchor end 202 of the suture 200.

[0058] Referring now to FIG. 2C, the chamber 206 is contained within the anchor housing 207. The chamber 206 may have a conical shape. However, the shape of the chamber 206 and even the anchor end 202 can vary. For example, the chamber may be rectangular, curved, semi-spherical, or any other known shape that can function to receive the fastener end 201 of the suture 200 and secure the fastener end 201 to the anchor end 202. In an alternate embodiment, the suture thread 203 may be looped through the chamber 206 and tied around the anchor housing 207, and extend and connect to the fastener end 201. In another implementation, the suture thread 203 may be embedded in, molded in, or otherwise fixed to the anchor housing 207 of the anchor end 202.

[0059] When the first fastener mechanism 204 of the fastener end 201 passes through the chamber 206 in an upward direction, the conical shape of the chamber 206 receives the first fastener mechanism 204 and locks the first

fastener mechanism **204** over the top of the chamber **206**. This inhibits the fastener end **201** from returning backwards through the chamber **206**.

[0060] It should be understood that the fastener end **201** and the anchor end **202** may utilize any known geometrical configurations and/or locking mechanisms and are not limited to any one particular configuration. For example, the fastener end may have one or more ridges, the ridges being similar to a barb on a fish hook. These ridges may be designed to lock into a chamber of the anchor end. The chamber can have a structure to facilitate the locking of the fastener end into the anchor end, such as a curved shoulder to allow for the ridges to enter the chamber, but not allowing the ridges to exit the chamber in the direction that the ridges entered into the chamber. Of course, the shape of the fastener end can vary and is not limited to having a surface with one or more ridges. For example, in another alternate implementation of the fastener end, the fastener end may have a flat surface and a surface with one or more ridges opposite from the flat surface.

[0061] The chamber may have one or more shoulders configured to allow the fastener end to enter the chamber in a unidirectional manner.

[0062] When the fastener end passes through the chamber in an upward direction, the ridges of the fastener end pass the shoulders. The ridges lay on top of the shoulders to inhibit the fastener end from moving in a downward direction. This inhibits the fastener end from escaping the chamber and secures the fastener end inside the anchor end. As stated above, the shape of the fastener end and the anchor end are not limited to the implementations previously stated, and various other shapes and configurations may be used to secure the fastener end to the anchor end.

[0063] FIGS. 3A-3E show views of a suturing device and housing, in accordance with one or more embodiments (e.g., including embodiments described in more detail in Sections 2.1 and 2.2 below). FIG. 3A shows a view of a suturing device over tissue in a middle position; FIG. 3B shows a view of a suturing device over tissue in an end position; FIG. 3C shows a cross-sectional view of a suturing device over tissue in an end position; FIG. 3D shows a view of a suture housing that is filled with sutures; FIG. 3E shows a view of an empty suture housing. As illustrated in FIGS. 3A-3E, a suturing device **300**, in accordance with various implementations of the invention includes a suture housing **301**, a suturing needle **302**, one or more sutures **304**, a suture magazine **303** configured to hold the one or more sutures **304**, and a drive system **305** configured to actuate the rotation of the suturing needle **302** in a first direction into a tissue **310** and a second direction that is opposite the first direction to apply one or more sutures **304** to the tissue **310**, or to apply one or more sutures **304** to mount an implant (e.g., synthetic mesh) onto the tissue **310**.

[0064] FIG. 4, in accordance with one or more embodiments (e.g., including embodiments described in more detail in Sections 2.1 and 2.2 below) depicts a laparoscope with suturing device, in accordance with one or more embodiments (e.g., including embodiments described in more detail in Sections 2.1 and 2.2 below). A laparoscope with suturing device **400** can be implemented, for example, with suturing device **300** mounted at a distal end of a standard laparoscope. The laparoscope may include a stem **402** and a trigger (not shown). The stem **402** of the laparoscope has a length long enough to allow the surgeon to operate the suturing

device (e.g., device **300**) from a location outside of the patient while the suturing device is in contact with tissue. The stem **402** is coupled to a drive system, for example, drive system **305**, of the suturing device via clamps **404**. The trigger (not shown) is located at the proximal end of the laparoscope. The surgeon can squeeze the trigger (not shown) to apply a force to the drive system **305** (via clamps **404**), and thus engage the suturing device **300** to apply a suture.

[0065] In another implementation, the suturing device **300** may be mounted to the distal end of a robotic-assisted surgical forceps arm. A sheath made of a non-ridged sterile material may be used to connect the proximal end of the suture housing **301** to the distal end of the robotic-assisted surgical forceps arm. The sheath allows flexibility in orienting the suturing device **300** in different directions. The surgeon can close the forceps on the robotic-assisted surgical forceps arm to apply a force to the drive system **305**, and thus engage the suturing device **300** to apply a suture **304**. Alternatively, the suturing device **300** may be actuated as a robotic arm that works in tandem with a robotic-assisted surgical system. The surgeon can operate the suturing device **300** at a console to administer sutures **304**.

[0066] Referring back to FIGS. 3A and 3B, the suture housing **301** of the suturing device **300** encloses the suturing needle **302**, the one or more sutures **304**, the suture magazine **303** configured to hold the one or more sutures **304**, and the drive system **305**. The suturing needle **302** can have a shaft **311** forming a rod axis **107**, a curved body **306** having a piercing tip **308** at one end and a base **312** at another end, and an arm **307** extending radially from the shaft **311** to the base **312** of the curved body **306** so that the curved body **306** is positioned in a plane orthogonal to the rod axis **107** of the shaft **311** and rotatable about the shaft **311** in the plane orthogonal to the rod axis **107**. The suturing needle **302** may also be designed in accordance with the suturing needle **100** or **110** as described in FIGS. 1A, 1B, and 1C.

[0067] The one or more sutures **304** of the suturing device **300** each comprises a fastener end, an anchor end, and a suture thread extending between the fastener end and the anchor end. The one or more suture may be designed in accordance with the suture illustrated in FIG. 2A. Additionally, the fastener end and the anchor end may be designed as described with respect to the fastener end illustrated in FIG. 2A, and the anchor end illustrated in FIGS. 2A, 2B, and 2C.

[0068] Referring now to FIGS. 5A and 5B, one or more embodiments (e.g., including embodiments described in Sections 2.1 and 2.2 below) of the suture housing **301** of the suturing device **300** has an aperture in the plane orthogonal to the rod axis of the suturing needle **302** that permits exiting of the suturing needle **302** and one of the one or more sutures **304** from the suture housing **301**. The suture housing **301** can have a curved upper interior surface and a flat lower interior surface, where the aperture is in the flat lower interior surface. The curved upper interior surface of the suture housing **301** is slightly longer than the flat interior lower surface to allow the suturing needle **302** to rotate in to and out of the tissue **310** to apply a suture **304** (see FIGS. 3A, 3B, and 3C). However, the shape of the suture housing **301** can vary and is not limited to having a curved upper interior surface and a flat lower interior surface. In one implementation, the curved upper interior surface of the suture housing **301** may have a needle track that maintains

the suturing needle 302 within the plane orthogonal to the rod axis of the suturing needle 302.

[0069] The suture housing 301 may be made of a rigid sterile material, and the suture housing 301 may be discarded after use, or sterilized and re-used for numerous procedures. Additionally, in one implementation, the suture magazine 303 may be discarded after use, and may be replaced with another suture magazine 303. The suture magazine 303 is configured to hold the one or more sutures 304 within the suture housing 301 so that the fastener end 201 of the one or more sutures 304 can be positioned to be grasped by one end of the curved body 101 of the suturing needle 302 as it exits the aperture in the suture housing 301 at one side of the shaft 103 of the suturing need 302, and the anchor end 202 can be positioned to exit the aperture in the suture housing 301 at another side of the shaft 103 of the suturing needle 302. The suture magazine 303 is seated on to the flat lower surface of the suture housing 301 towards the distal end of the suturing device 300.

[0070] FIG. 6A depicts an implementation of a suture magazine 600 that may be used in the suturing device 300 as shown in FIG. 3A, in accordance with one or more embodiments (e.g., including embodiments described in more detail in Sections 2.1 and 2.2 below). Each suture can have a fastener end 602, an anchor end 603, and a suture thread 604 connected to and extending between the fastener end 602 and the anchor end 603. The suture thread 604 may be made of biodegradable material such as polydioxanone (PDS), polypropylene, or the like. In one implementation, the suture may be designed in accordance with the suture illustrated in FIG. 2A. Additionally, the fastener end 602 and the anchor end 603 may be designed in accordance with the fastener end 201 illustrated in FIG. 2A and the anchor end 202 illustrated in FIGS. 2B and 2C. The suture magazine 600 can include elastic members 601. The elastic members 601 can be made of rubber or another elastic material. The elastic members 601 have a distal end that is towards the suture needle 100 and a proximal end that is towards the hub. The distal end of the elastic members 601 is attached to the suture housing cover 605 and the proximal end is attached to the suture movers 606. The suture movers 606 are configured to slide within the suture magazine 600 such that when a suture is used and leaves through the aperture in the suture housing 301, the force created by the elastic members 601 pulls the suture movers 606 forward which in turn pushes any remaining sutures forward towards the distal end of the suturing device 300. In an alternate embodiment, a spring can be placed on the proximal end (behind) of the suture movers 606 so that the sutures can be moved forward when a suture is used and leaves through the aperture in the suture housing 301. The spring can be used as a replacement to or in combination with the elastic members 601 to move the sutures forward each time a suture is used and leaves through the aperture in the suture housing 301. The spring/suture movers combination or the elastic members/suture movers combination may be used as a loading mechanism in contact with the suture magazine 600. The loading mechanism is not limited to these combinations. The loading mechanism may be any structure that can be tensioned to apply a force to the suture magazine 600.

[0071] FIG. 6B shows the suture magazine 600 positioned inside the suture housing 301 of the suturing device 300, in accordance with one or more embodiments (e.g., including embodiments described in more detail in Sections 2.1 and

2.2 below). When the suture magazine 600 is seated on to the flat lower interior surface of the suture housing 301, the suture thread 604 lays laterally behind the suturing needle 302 and across the flat lower interior surface of the suture housing 301. The suturing needle 302 can be actuated to rotate in the plane orthogonal to the tissue to drive in to and out of the tissue to apply a suture.

[0072] In embodiments, the suturing needle 302 has a curved body 306, an arm 307, and a shaft 311. The curved body 306 may have a piercing tip 308 at one end and a base 312 at the other end. The shaft 311 can form a rod axis. In one implementation, the suturing needle 302 may also have a grasping edge 309 that is configured to form an edge between the grasping edge 309 and the piercing tip 308. This allows for the piercing tip 308 to enter the tissue in a curved motion with the first fastener mechanism 313 in tow, and exit the tissue while simultaneously inserting the first fastener mechanism 313 through the chamber 314 or the anchor housing 315.

[0073] In alternate embodiments, the needle may also include a groove 113 extending from the piercing tip 111 along at least a portion of an outer surface of the curved body 306. The groove 113 can be configured to maintain the fastener end 602 in a position along the outer surface of the curved body 306 of the suturing needle 302. In another implementation, the fastener end 602 can include a suture guide loop, and the grasping element 312 of the suturing needle 302 may grab the suture guide loop to pull the fastener end 602 from the belt and enter the tissue in a curved motion with the fastener end 602 in tow, and exit tissue while simultaneously inserting the fastener end 602 into the anchor end 603.

[0074] In one implementation, the suturing needle 302 can be actuated by the drive system 305. The drive system 305 is coupled to the shaft 311 of the suturing needle 302, whereby the curved body 306 is positioned in a plane orthogonal to drive system 305. The suturing needle 302 can rotate in a first direction and a second direction that is opposite the first direction, in the plane orthogonal to tissue from a starting position to an end position. In the starting position (see FIG. 1B), the curved body 306 of the suturing needle 302 is stationary inside the suture housing 301 in the plane orthogonal to the drive system 305, the fastener end 602 of the suture is in place for grasping by the suturing needle 302, and the anchor end 603 of that suture is positioned away from the aperture in the suture housing 301. In a motion to the end position, the needle 302 rotates in the first direction from the starting position, grasps the fastener end 602 while the anchor end 603 is moved into position over the aperture in the suture housing 301, and continues to rotate into tissue in a curved path on a plane orthogonal to tissue, inserting the fastener end 602 into the anchor end 603. At the end position (see FIGS. 3A and 3C), the suturing needle 302 automatically rotates in the second direction to return to the starting position. As the suturing needle 302 returns to the starting position, the arm 307 of the suturing needle 302 comes into contact with the anchor end 603. The anchor end 603 is pushed out of the aperture in the suture housing 301 by the arm 307 of the suturing needle 302, allowing a next suture to have its fastener end 602 to move into position for grasping by the suturing needle 302. The fastener end 602 is released from the suture magazine 600 as the suture needle 302 and grasping edge 309 grasp the fastener end 602 and drag the fastener end 602 along a

curved path to be inserted through the anchor end 603. The elastic members 601 apply a pulling force to the suture movers 606 which in turn apply a pushing force to the fastener end 602 and the anchor end 603, allowing another fastener end 602 and anchor end 603 to move into position to be grappled by the needle 302. When the fastener end 602 is inserted into the anchor end 603, the fastener end 602 is configured to be pulled through or locked within the anchor end 603 upon insertion to retain the suture under tension.

[0075] In an implementation incorporating a spring, after the fastener end 602 is released from the notch of the belt as the suturing needle 302 grasps the fastener end 602 and drags the fastener end 602 along a curved path to be inserted into the anchor end 603, the spring applies a pushing force to the anchor end 603 that urges the belt and the anchor end 603 forward, allowing another fastener end 602 to move into position to be grappled by the needle 302. When the fastener end 602 is inserted into the anchor end 603, the fastener end 602 is configured to lock with the anchor end 603 upon insertion to retain the suture under tension.

[0076] In an alternate embodiment, a suture magazine can include a belt having one or more notches, and at least one suture. The belt is positioned parallel to the anchor end 603. The belt may be made of rubber or another elastic material. The fastener end 602 is releasably secured to the notch of the belt. In one implementation, a crossbar can be attached to the belt. The crossbar has a first end and a second end. The first end is fixed to the belt, and the second end is in contact with the anchor end 603. A spring may be located behind the crossbar and positioned behind the anchor end 603.

[0077] FIGS. 7A-7D show an automatic suture tightening technique, in accordance with one or more embodiments (e.g., including embodiments described in more detail in Sections 2.1 and 2.2 below). In FIG. 7A, a suture 700 is shown in a starting position over top of tissue 710. Next, as shown in FIG. 7B, the first fastener mechanism 704 of the fastener end 701 is inserted through an entry point of the tissue 710 and carried through the tissue 710 along a curved path by a suturing needle. In this embodiment, the suturing needle pushes the first fastener mechanism 704 along the fastener grasping edge 708A. As the suturing needle continues along the curved path and reaches an ending position, as shown in FIG. 7C, the first fastener mechanism 704 is pushed through the chamber 706 of the anchor end 702. The suture thread 703 pulls the second fastener mechanism 705 through the tissue 710 along the same curved path as first fastener mechanism 704. As the suture 700 is released from the suturing device, the fastener grasping edge 708A can rest on top of the anchor housing 707. At this stage, there is no tension on the suture thread 703. As shown in FIG. 7D, after the first fastener mechanism 704 is pulled in an upward direction, the second fastener mechanism 705 is pulled through the chamber 706 of the anchor end 702 and causes the tissue 710 to be pulled together. The suture 700 is designed so that when the second fastener mechanism 704 is pulled through the chamber 706 of the anchor end 702, a predetermined tension is created throughout the suture thread 703. At this point, the fastener grasping edge 708B prevents the second fastener mechanism 705 from moving backward through the chamber 706 of the anchor end 702.

[0078] In another implementation, as shown in FIG. 8, in accordance with an implementation of a suture as described with respect to FIG. 4, the surgeon may manually grasp the first fastener mechanism 704 with a separate laparoscopic

instrument and pull the first fastener mechanism 704 upward to tighten the suture thread 703 until the second fastener mechanism 705 is pulled through the chamber 706 to provide the desired tension on the suture. In another implementation, the surgeon may manually grasp the suture guide loop with a separate laparoscopic instrument and pull the suture guide loop upward to tighten the suture thread 703. Alternatively, the suturing device may have a hook positioned on the exterior of the suture housing, and the surgeon may manually tighten the suture using the hook rather than using an additional laparoscopic instrument.

[0079] As shown in FIG. 8, as the base 709 and the arm 710 return to the starting position, the base 709 pushes the anchor end 702 through the suture housing aperture 711, allowing the next fastener end 701 to be moved into position by the elastic member 601 and the suture mover 606 (not shown in this figure).

[0080] In another implementation, the suture housing of the suturing device 300 may have a clamp positioned along the interior surface of the suture housing that grasps the suture guide loop as the fastener end 702 enters the anchor end 703. As the suturing device is pulled away from tissue, the suture is tightened, and the clamp releases the suture guide loop once the suture reaches a predetermined tension. In an alternate embodiment, the clamp can grasp the suture guide loop as the fastener end 702 enters the anchor end 703.

[0081] In another implementation, the suture housing may have a catch attached to the interior surface of the suture housing to a side of the aperture, as described with respect to FIG. 5B. The catch can releasably grasp the suture guide loop of the fastener end 702 as the arm 710 of the suturing needle pushes down on the anchor end 703 when returning to the starting position. The catch automatically releasing the suture guide loop once the suture reaches a predetermined tension. Alternatively, the catch can releasably grasp the suture guide loop as the suturing device is pulled away from tissue and the catch automatically releasing the suture guide loop once the suture reaches a predetermined tension. In an alternate embodiment, the catch can be adapted to perform the same functions with a fastener mechanism that is described above with respect to a suture guide loop.

[0082] FIGS. 9A-9F show a drive system 900 that can be used to operate the suturing device 300 (see FIGS. 3A-3C), in accordance with one or more embodiments (e.g., including embodiments described in more detail in Sections 2.1 and 2.2 below). The drive system 900 includes a tube 901 and a rod 902. The diameter of the rod 902 is smaller than the diameter of the tube 901. The rod 902 may include one or more protrusions 903 positioned on the exterior surface of the rod 902 towards the proximal end. The tube 901 may have one or more grooves 904 that extend in a spiral manner from a proximal end of the tube 901 towards the distal end of the tube 901. Each groove 904 can correspond to one of the one or more protrusions 903. The one or more protrusions 903 attached to the rod 902 are configured to move along the one or more grooves 904 within the tube 901.

[0083] In one implementation, the proximal end of the rod 902 may abut a hub 905, and the distal end of the rod 902 is coupled to a shaft 311 of a suturing needle. The shaft can be in the tube 901 and the rod 902. The tube 901 can have the hub 905 positioned at the proximal end of the tube 901. The rod 902 is configured to remain fixed along a direction of a rod axis of the shaft while being able to rotate about the rod

axis. The tube 901 is configured to remain fixed in a radial direction while being movable forward and backward along the rod axis.

[0084] In a starting position, the rod 902 is positioned inside the tube 901, where the protrusions 903 lay on the grooves 904 of the tube 901, and the hub 905 of the tube 901 meets the proximal end of the rod 902. As a force pushes on the hub 905, the grooves 904 engage the protrusions 903 of the rod 902 and the tube 901 drives along the rod 902 from the proximal end of the rod 902 to the distal end of the rod 902, thereby rotating the rod 902 forward as the protrusions 903 travel along the grooves 904 of the tube 901. Once the force is withdrawn from the proximal end of the tube 901, the tube 901 reverses direction from the distal end of the rod 902 to the proximal end of the rod 902, thereby rotating the rod 902 backward as the protrusions 903 travel along the grooves 904 in the opposite direction.

[0085] In order to connect the drive system 900 to a surgical device, such as a laparoscopic device, the distal end of the hub handles 906 are attached to the hub 905. At the proximal end of the hub handles 906, clamp head receiving members 907 are attached to receive a grasping clamp 909 from a surgical device. Clips 908 are positioned around the clamp head receiving members 907 and the grasping clamp 909 so that the clamp head receiving members 907 and the grasping clamp 909 are secured to one another.

[0086] In one implementation, the rod 902 of the suturing needle 302, as described with respect to FIG. 6B, is connected to the distal end of the rod 902. Therefore, when the tube 901 drives along the rod 902, both the rod 902 and the suturing needle 302 rotate in a first direction, which allows the suturing needle 302 to deploy from the suture housing 301 and grasp the fastener end 602. As the suturing needle 302 rotates and inserts the fastener end 602 into the anchor end 603, the protrusions 903 have traveled the complete length of the grooves 904 of the tube 901, and the rod 901 ceases rotational movement. When the force is withdrawn from the proximal end of the tube 901, the fastener end 602 remains locked in the anchor end 603, and the tube 901 reverses direction causing both the rod 902 and the suturing needle 302 to rotate in a second direction until the protrusions 903 travel the length of the grooves 904 in the opposite direction, retracting the suturing needle 302 into the suture housing 301. As the suturing needle 302 retracts back in to the suture housing 301, the arm 710 of the suturing needle 302 will push down on the anchor end 603, allowing the entire suture to release from the device.

[0087] In one implementation, the hub 905 of the tube 901 can be coupled to a manual trigger. A trigger, as described with respect to FIG. 4, may apply a force to the hub 905 of the tube 901, engaging the drive system 900. The trigger is connected to the proximal end of a manual arm. The manual arm can be the laparoscope. The drive system 900 can be connected to the distal end of the stem of the laparoscope. Upon the surgeon squeezing the trigger, the tube 901 is propelled forward along the rod 902, resulting in both the rod 902 and the suturing needle 302 rotating in a first direction. Once the trigger is released, the tube 901 reverses direction, causing both the rod 902 and the suturing needle 302 to rotate in a second direction until the protrusions 903 travel the length of the grooves 904 in the opposite direction, retracting the suturing needle 302 into the suture housing 301.

[0088] In another implementation, the hub 905 of the tube 901 can be coupled to a robotic arm or incorporated as a robotic arm as part of a robotic-assisted surgical system. A robotic-assisted surgical system forceps arm, may apply a force to the hub 905 of the tube 901, engaging the drive system 900. The robotic-assisted surgical forceps arm is attached to a main hub of the robotic-assisted surgical system at its proximal end, and includes forceps at its distal end. The main hub of the robotic-assisted surgical system contains one or more robotic arms that the surgeon can control from a distance at a console. A sheath made of a non-ridged sterile material may be used to connect the proximal end of the suture housing 301 of the suturing device 300, to the distal end of the robotic arm.

[0089] Forceps may be positioned at the proximal end of the drive system 900. A hinge may be inserted into the forceps of the robotic-assisted surgical forceps arm. The hinge may include a spring tensioned to keep the forceps open at a certain angle when the hinge is inserted into the forceps. Upon closing the forceps, the hinge compresses and lengthens the forceps. The lengthened forceps come into contact with the tube 901 and apply a force to the tube 901 that propels the tube 901 forward along the rod 902, which causes the rod 902 and the suturing needle 302 to rotate in the first direction. When the surgeon opens the forceps, the tube 901 reverses direction causing both the rod 902 and the suturing needle 302 to rotate in a second direction until the protrusions 903 travel the length of the grooves 904 in the opposite direction, retracting the suturing needle 302 into the suture housing 301.

[0090] FIG. 10 shows a side view of an alternative drive system in accordance with an implementation of the invention. Referring to FIG. 10, drive system 1000 can be used to operate a suturing device. The drive system 1000 includes a tube 1001 and a rod 1002. The diameter of the rod 1002 is smaller than the diameter of the tube 1001. The tube 1001 may include one or more protrusions 1003 positioned on the interior surface of the tube 1001 towards the proximal end. The rod 1002 may have one or more grooves 1004 that extend in a spiral manner from a proximal end of the rod 1002 towards the distal end of the rod 1002. Each groove 1004 can correspond to one of the one or more protrusions 1003. The one or more protrusions 1003 attached to the tube 1001 are configured to move along the one or more grooves 1004 within the rod 1002.

[0091] In one implementation, the proximal end of the tube 1001 may abut a hub 1005, and the distal end of the tube 1001 is coupled to a rod 1002 of a suturing needle. The rod 1002 can have the hub 1005 positioned at the proximal end of the rod 1002. The hub 1005 is attached to the hub handles 1006 which are configured to attach to a forceps or laparoscopic device. The tube 1001 is configured to remain fixed along a direction of a rod axis of the rod 1002 while being able to rotate about the rod axis. The rod 1002 is configured to remain fixed in a radial direction while being movable forward and backward along the rod axis.

[0092] In a starting position, the rod 1002 is positioned inside the tube 1001, where the protrusions 1003 lay on the grooves 1004 of the rod 1002 and the hub 1005 of the rod 1002 meets the proximal end of the tube 1001. As a force pushes on the hub 1005, the grooves 1004 engage the protrusions 1003 of the tube 1001 and the rod 1002 drives along the tube 1001 from the proximal end of the tube 1001 to the distal end of the tube 1001, thereby rotating the tube

1001 forward as the protrusions **1003** travel along the grooves **1004** of the rod **1002**. Once the force is withdrawn from the proximal end of the rod **1002**, the rod **1002** reverses direction from the distal end of the tube **1001** to the proximal end of the tube **1001**, thereby rotating the tube **1001** backward as the protrusions **1003** travel along the grooves **1004** in the opposite direction.

[0093] Suturing devices, needles, sutures, and drive systems are presented herein.

[0094] According to some embodiments, a suture is provided comprising: a fastener end; an anchor end; and a suture thread connected to and extending between the fastener end and the anchor end. The fastener end can comprise a first and second conical shaped structure, the first and second conical shaped structure having a top and a bottom, the suture thread fixed to the top, the bottom being larger than the top. The anchor end can comprise an anchor housing and a chamber, the interior surface of the chamber having a conical shape. The first conical shaped structure can be configured to slide through the anchor housing and remain locked in the anchor end once the first conical shaped structure is inserted through the chamber of the anchor end. The second conical shaped structure can be configured to be pulled through the chamber, wherein the pulling of the second conical shaped structure through the chamber tensions a suture to a predetermined tension level.

[0095] According to some embodiments, a suture magazine is provided comprising: a belt having one or more notches; at least one suture having a fastener end, an anchor end, and a suture thread connected to and extending between the fastener end and the anchor end, the anchor end positioned parallel to the fastener end, the fastener end releasably secured to the belt; a crossbar having a first end and a second end, the first end fixed to the belt, the second end in contact with the anchor end; and a spring in tension with the second end of the crossbar, wherein the spring applies a pushing force to the anchor end, urging the belt forward once a fastener has been released. The fastener end can comprise a curved enclosure having a ridged surface, a top, and a bottom, the suture thread fixed to the top, the bottom having a suture guide loop positioned laterally. The anchor end can comprise a rectangular enclosure and a chamber, the interior surface of the chamber having at least one shoulder.

2.1 System Variation

[0096] FIGS. 11A-11C depict exploded views of a system for suturing, in accordance with one or more embodiments. FIGS. 11D-11E depict cross sectional views of a system for suturing, the system including suture advancing components, in accordance with one or more embodiments.

[0097] Embodiments of the system **1100** depicted in FIG. 11A-11E are configured to provide suture magazine components with compact and reliable mechanisms for advancing sutures of a set of sutures toward a deployment position. Such components and configurations can provide improvements over mechanisms that tend to apply high deployment force when all sutures are loaded, with decreased deployment force as sutures are deployed. Such embodiments can implement “lost-motion” designs that allow ratcheting components of the mechanisms to travel only as far as needed between instances of suture deployment in a consistent manner appropriate to the suture capacity of the suture magazine. For instance, a “lost-motion” design allows the

ratcheting component to travel only as far as is required for the design of the suture, regardless of motion of other components.

[0098] Embodiments of the invention(s) can additionally or alternatively include needle features that increase range of delivery rotation of the needle into a tissue or other repair site.

[0099] As shown in FIGS. 11A-11E, an embodiment of the system **1100** for suturing includes a housing **1101** having an aperture **1111**. The system **1101** can also include a suturing needle **1102** retained within the housing **1101** and including: a shaft **1103** defining a rod axis **1107**, and a curved body **1104** comprising a piercing tip **1105** at a first region and a base **1106** coupled to the shaft **1103** at a second region of the curved body **1104** such that the base **1106** of the curved body **1104** is positioned in a first plane **1107a** intersected by the rod axis **1107** of the shaft **1103**, and the piercing tip **1105** is positioned in a second plane **1107b** intersected by the rod axis **1107** of the shaft **1103**.

[0100] In one variation, the first plane **1107a** is proximally displaced from the second plane **1107b**, relative to the shaft of the suturing needle. In another variation, the first plane **1107a** is distally displaced from the second plane **1107b**, relative to the shaft of the suturing needle. However, the first and the second planes **1107a**, **1107b** can be oriented relative to each other in another suitable manner (e.g., with non-parallel spacing relative to each other). In variations, the first plane **1107a** and the second plane **1107b** can be displaced from each other at a distance ranging from 0.1 mm to 15 mm; however, the first plane **1107a** and the second plane **1107b** can be spaced apart by another suitable distance in other variations. In still other variations, the first plane **1107a** and the second plane **1107b** may not be parallel and can otherwise be intersecting planes. In still other variations, the first plane **1107a** and the second plane **1107b** may not be planar, and can define non-planar surfaces defining angular or curved surfaces of the suturing needle **1102**.

[0101] The system **1101** can also include a suture magazine **1108** retained within the housing **1101** and including a suture advancer **1120** comprising a first track **1122** coupled to an internal portion of the housing **1101** and supporting a set of sutures **1130** between a first end **1109a** and a second end **1109b** of the suture magazine, and a second track **1124** opposing the first track **1122** about the set of sutures **1130** and configured to move within the housing **1101**, each of the set of sutures **1130** comprising a fastener end **1131** coupled to an anchor end **1133** (shown in FIG. 11C). The first and the second tracks **1122**, **1124** can be configured as trays having “bottom” surfaces for retaining the set of sutures **1130**; however, the first track **1122** and/or the second track **1124** can be configured with one or more open regions, such that the first track **1122** and **1124** are not containers having continuous/contiguous surfaces.

[0102] As shown in FIGS. 11D and 11E, the first track **1122** can include a first set of teeth **1125** retaining and separating (e.g., providing spacing between) adjacent sutures of the set of sutures **1130** at a first side. The first set of teeth **1125** can define a series of recessed regions within an interior channel of the first track **1125**, or can define another suitable geometry for retaining and separating adjacent sutures. The series of recessed regions can include sloping features in an advancement direction, where, in embodiments, the sloping features promote advancement of the set of sutures serially in one direction, but prevent

backward transmission of the set of sutures. The first set of teeth **1125** can thus contribute to smooth operation of the system in relation to advancing sutures through the aperture of the housing.

[0103] The second track **1124** can additionally or alternatively include a second set of teeth **1127** supporting the set of sutures **1130** at a second side in a suturing advancing mode provided by the system. The second set of teeth **1127** can define a series of recessed regions within an interior channel of the second track **1124**, or can define another suitable geometry for supporting and advancing adjacent sutures. The first set of teeth **1125** and/or the second set of teeth **1127** are complementary to surfaces of the set of sutures between the first track **1122** and the second track **1124**. As shown in FIGS. **11D** and **11E**, the first set of teeth **1125** and the second set of teeth **1127** can include a sawtooth morphology that is complementary to surfaces of the set of sutures **1130** between the first track and the second track. However, the sets of teeth **1125**, **1127** can have another toothed morphology for supporting the set of sutures and contributing to reliable operation of the system. Still other variations of the sets of teeth **1125**, **1127** can omit a toothed morphology and can define another suitable morphology for smooth operation in the suture advancing mode.

[0104] In embodiments, the first track **1122** and/or the second track **1124** can be composed of a polymer material, including one or more of: a polyvinyl chloride-derived material, a nylon-derived material, a polyethylene-derived material, a polycarbonate-derived material, an acrylonitrile butadiene styrene (ABS)-derived material, and another suitable polymeric material. However, variations of the first track **1122** and/or the second track can be composed of a non-polymeric material (e.g., a ceramic material, a metallic material, etc.).

[0105] Similar to embodiments described above, the system can include one or more biasing elements **1129** configured to ultimately transmit force for advancing sutures of the set of sutures **1130** as they are used during operation. The biasing element(s) **1129** can be coupled to one or more of the first track **1122** and the second track **1124**, and configured to apply pressure (e.g., in relation to a ratcheting mechanism) for advancing sutures forward.

[0106] The biasing element(s) **1129** can allow the second track **1124** to be displaced as necessary to move remaining sutures up and over the set of teeth of the first track **1122** appropriately when indexing sutures of the set of sutures **1130** forward. The biasing element(s) **1129** can be asymmetrically configured in relation to bilateral sides of the suture magazine **1108**. For instance, both sides of the second track **1124** can include biasing elements that can be compressed to generate a forward biasing force that advances remaining sutures forward. Additionally or alternatively, one side of the second track can be coupled to an additional coil spring (e.g., depicted in FIG. **13**) that functions to delay the timing of advancement on that side until the leading suture has been displaced from the suture magazine. This configuration of the suture magazine thus generates potential energy in the biasing elements (e.g., spring combinations) that compresses the suture heads of the remaining sutures, where the compression is relieved when the leading suture is displaced from the suture magazine.

[0107] In embodiments, the biasing element(s) **1129** can include one or more linear wave springs spanning the channel and preventing rocking between the first track and

the second track. The linear wave spring(s) can contribute to a mechanism that keeps the set of sutures **1130** level (e.g., all substantially along a similar axis) within the suture magazine **1108**, for reliable operation of the system. Additionally or alternatively, the biasing element(s) **1129** can include one or more of: non-linear springs, elastomeric elements, hydraulic elements, magnetic elements, and/or other suitable elements that store and release potential energy for advancement and indexing of the set of sutures **1130** in a forward direction.

[0108] In the embodiment shown in FIG. **11D**, the second track **1124** includes a channel **1123** supporting a biasing element **1129** (e.g., linear wave spring), where the biasing element contributes to an advancing mode of the suture magazine **1108**. The channel **1123** opposes surfaces of the second track **1124** interacting with the set of sutures **1130**. In the advancing mode, a leading suture of the set of sutures **1130** is displaced from the first end of the suture magazine by a compressive force applied by at least one of the biasing element **1129** and the suture advancer **1120** to the second track **1124**. However, the biasing element(s) can additionally or alternatively be coupled to the first track **1122** (e.g., within a channel) and/or in another suitable manner.

[0109] The first track **1122** and second track **1124**, in cooperation with the biasing element **1129**, thus provide improvements over mechanisms that tend to apply high deployment force when all sutures are loaded, with decreased deployment force as sutures are deployed. Such a configuration provides a “lost-motion” design that allow ratcheting components of the mechanisms to travel only as far as needed between instances of suture deployment in a consistent manner appropriate to the suture capacity of the suture magazine. For instance, a “lost-motion” design allows the ratcheting component to travel only as far as is required for the design of the suture, regardless of motion of other components.

[0110] The system can also include a drive system (e.g., such as the drive system components described in relation to FIGS. **9A-9F** and **10**) that transforms an applied force into rotation of the shaft **1103** of the suturing needle **1102** thereby engaging and inserting the fastener end **1131** into the anchor end **1133** of a leading suture **1135** of the set of sutures **1130** and displacing the leading suture **1135** from the aperture **1111** of the housing **1101**. In relation to configuration of the suturing needle **1102** relative to the housing **1101** and displacement between the piercing tip **1105** and the base **1106** of the suturing needle **1102** with respect to the first plane **1107a** and the second plane **1107b**, the drive system is configured to transition the curved body **1104** of the suturing needle through greater than 180° of delivery rotation through the aperture of the housing. However, alternative configurations between the suturing needle **1102**, the housing **1101**, and the drive system can be configured to provide another suitable range of delivery rotation.

[0111] Similar to mechanisms described above (e.g., in relation to FIGS. **7A-7D** and **8**), engagement of the drive system is configured to transition the suturing needle between a first operation mode and a second operation mode, wherein, in the first operation mode, the piercing tip **1105** of the curved body **1104** engages the fastener end **1131** of the leading suture as it exits the aperture **1111** for transmission of the fastener end **1131** and piercing tip **1105** into a tissue or other repair site material, and then insertion into the anchor end **1133** of the leading suture. Then, in the

second operation mode, the curved body **1104** moves (e.g., rotates in reverse) and displaces the anchor end **1133** of the leading suture from the housing **1101**. The system can transition between the first and the second operation mode as described above in relation to FIGS. **7A-7D** and **8**, or in another suitable manner.

[**0112**] FIG. **12A** depicts a first needle component of a system for suturing, in accordance with one or more embodiments. FIG. **12B** depicts a second needle component of a system for suturing, in accordance with one or more embodiments. As shown in FIGS. **12A** and **12B**, the suturing needle **1202** can include a curved body **1204**. The curved body **1204** can include a helical body **1205**, as shown in FIGS. **12A** and **12B**. The helical body **1205** contributes to the ability of the system to transition the curved body **1204** of the suturing needle through greater than 180° of delivery rotation through the aperture of the housing. The helical body **1205** can have constant curvature along its length in one embodiment, such that a projection of the helical body **1205** onto a plane perpendicular to its longitudinal axis defines a circle. In other embodiments, the helical body **1205** can have non-constant curvature, such that a projection of the helical body onto a plane perpendicular to its longitudinal axis defines a polygon or amorphous shape. In allowing reliable operation of the system, the aperture of the system can define an opening that allows the curved body **1205** to pass through the aperture through its entire range of motion during operation of the system. As such, the aperture can span a width of the housing, and open longitudinally along the housing in a manner that allows the curved body **1205** to pass through the aperture through its entire range of motion.

[**0113**] In the embodiment shown in FIGS. **12A** and **12B**, the curved body **1204** of the suturing needle **1202** includes a straight portion **1206** coupling the piercing tip **1207** to the helical body **1205**. The straight portion **1206** functions to facilitate driving of the piercing tip **1207** through tissue (or other material) at a repair site. Additionally or alternatively, in other embodiments, the suturing needle **1202** can include other suitable morphology (e.g., portions of reduced cross sectional area near the piercing tip, etc.) to facilitate driving of the piercing tip **1207** through tissue (or other material) at a repair site.

[**0114**] As shown in FIGS. **12A** and **12B**, the curved body **1204** of the suturing needle **1202** can additionally or alternatively include a recessed region **1208** configured to face a leading suture of the suture magazine during operation (e.g., in the configuration shown in FIGS. **11A-11C**). The recessed region **1208** functions to provide clearance between the suture and the suturing needle **1202** during operation, while not impacting needle strength (e.g., given that, during operation, a position of maximum stress is positioned near the base **1209** of the suturing needle **1202**).

[**0115**] Embodiments of the suturing needle can additionally or alternatively include other morphologies configured to facilitate improved access to tissue or other material at a repair site, and/or to produce smoother operation in relation to other components of the system.

[**0116**] Embodiments of the system can also include a reduced subset of elements in order to operate. For instance, in one embodiment, a system for suturing can include: a housing having an aperture; a suturing needle retained within the housing and including a shaft defining a rod axis, and a curved body comprising a piercing tip at a first region and a base coupled to the shaft at a second region of the

curved body such that the base of the curved body is positioned in a first plane intersected by the rod axis of the shaft, and the piercing tip is positioned in a second plane intersected by the rod axis of the shaft; a suture magazine retained within the housing and holding a set of sutures, each comprising a fastener end coupled to an anchor end; and drive system that transforms an applied force into rotation of the shaft of the suturing needle thereby engaging and inserting the fastener end into the anchor end of a leading suture of the set of sutures and displacing the leading suture from the aperture of the housing. Embodiments of such a system are depicted in the figures.

[**0117**] Furthermore, in relation to coupling to surgical instruments or other medical devices, embodiments of the system components depicted in FIGS. **11A-11E** and **12A-12B** can be configured to cooperate with FIGS. **1A** through **10**.

2.2 Additional System Elements and Variations

[**0118**] FIG. **13** depicts an exploded view of an embodiment of a suture magazine, in accordance with one or more embodiments of a suturing system. In more detail, FIG. **13** depicts components of a ratchet advancement mechanism that includes structures and biasing elements for moving the sutures through the suture magazine. The mechanism enabled by the components shown in FIG. **13** enables the suture magazine to advance remaining sutures for placement into a tissue, without providing too high of a force when the suture magazine is full of sutures, and without providing too low of a force when the suture magazine has fewer sutures. As shown in FIG. **13**, one side of the second track **1324** can be coupled to an additional coil spring **1327** that functions to delay the timing of advancement on that side until the leading suture has been displaced from the suture magazine. The additional coil spring **1327** can be positioned distally relative to the biasing element **1329**; however, the additional coil spring **1327** can be positioned relative to the biasing element **1329** in another suitable manner. In variations, the additional coil spring **1327** can be omitted, and the biasing element can alternatively include a region providing suitable elastic properties (e.g., in terms of stiffness) different from an opposing biasing element at the other track, in order to delay timing of advancement of different suture portions. This configuration of the suture magazine thus generates potential energy in the biasing elements (e.g., spring combinations) that compresses the suture heads of the remaining sutures, where the compression is relieved when the leading suture is displaced from the suture magazine.

[**0119**] FIG. **14** depicts multiple views of a suturing needle **1402** for placing sutures, in accordance with one or more embodiments of a suturing system. The suturing needle includes a piercing tip **1407** and a base **1408** and is configured to rotate about an axis defined by a shaft coupled to the suturing needle, to place sutures of the suture magazine at a repair site.

[**0120**] FIG. **15A** depicts embodiments of a suture, in accordance with one or more embodiments of a suturing system. A first embodiment of the suture **1501a** (FIG. **15A**, foreground) includes an anchor end **1502a**, a fastener end **1503a**, and a tensioning body **1504a** (positioned between the anchor end and the fastener end) along a suture thread **1505a**. A second embodiment of the suture **1501b** (FIG. **15A**, background) includes an anchor end **1502b**, a fastener end **1503b**, and along a suture thread **1505b**.

[0121] The suture embodiments depicted in FIG. 15A can be composed of a biodegradable material, such that the suture embodiments are bioresorbable. However, the suture embodiments can additionally or alternatively be composed of other materials (e.g., non-bioresorbable materials). Biodegradable suture materials from which the suture embodiments are composed can include one or more of: polylactic acid (PLA)-derived materials, monocryl, polydioxanone, bioresorbable polypropylene, and other bioresorbable materials. Non-biodegradable suture materials from which the suture embodiments are composed can include one or more of: nylon, polyester, polypropylene, polyvinylidene fluoride, and other non-bioresorbable but biocompatible materials. In the embodiment shown in FIG. 15A, the anchor ends **1502a**, **1502b** and the fastener ends **1503a**, **1503b** are composed of poly-D,L-lactic acid (PDLLA) or another biodegradable material. The suture threads **1505a**, **1505b** are composed of biodegradable material such as polydioxanone (PDS), polypropylene, or another biodegradable material.

[0122] FIG. 15B depicts an embodiment of a suturing needle interaction with a suture, in accordance with one or more embodiments of a suturing system. During placement of a leading suture, the piercing end of the suture needle interacts with the fastener end **1503b** of a suture to drive it (by rotation) into a repair site.

[0123] FIG. 15C depicts operation of an embodiment of a suture, in accordance with one or more embodiments of a suturing system. As shown in FIG. 15C, when a suture is placed at a repair site, the fastener end **1503b** passes through a chamber of the anchor end **1502b**, and then is retained at a retention surface of the anchor. The retention surface shown in FIG. 15C contributes to a 10 degree angle between the retention surface and a corresponding base surface of the fastener end, that allows the fastener and the anchor to lock together in an efficient manner. Another suitable angle can be provided by the retention surface.

[0124] FIG. 16 depicts an embodiment of an attachment for control of an embodiment of a suturing system. The embodiments of the attachment allow different surgical tools and/or robotic components to interface with the suturing needle and/or suture magazine to control operation of suture placement and/or driving of remaining sutures forward for placement. In related embodiments, the attachment can include one or more of: a flexible boot, a flexible sleeve, a snap configured to snap into corresponding slots, a band or tie to interface with jaws, a ring magnet, an elastomer tube, a C-channel slip, threaded fasteners, and any other suitable attachment structure.

3. Conclusion

[0125] Any reference in this specification to “one implementation,” “an implementation,” “example implementation,” etc., means that a particular feature, structure, or characteristic described in connection with the implementation is included in at least one implementation of the invention. The appearances of such phrases in various places in the specification are not necessarily all referring to the same implementation. In addition, any elements or limitations of any invention or implementation thereof disclosed herein can be combined with any and/or all other elements or limitations (individually or in any combination) or any other invention or implementation thereof disclosed herein, and all such combinations are contemplated with the scope of the invention without limitation thereto.

[0126] It should be understood that the examples and implementations described herein are for illustrative purposes only and that various modifications or changes in light thereof will be suggested to persons skilled in the art and are to be included within the spirit and purview of this application.

[0127] The language used in the specification has been principally selected for readability and instructional purposes, and it may not have been selected to delineate or circumscribe the inventive subject matter. It is therefore intended that the scope of the disclosure be limited not by this detailed description, but rather by any claims that issue on an application based hereon. Accordingly, the disclosure of the embodiments is intended to be illustrative, but not limiting, of the scope of the disclosure, which is set forth in the following claims.

What is claimed is:

1. A system for suturing, the system comprising:
 - a housing having an aperture;
 - a suturing needle retained within the housing and comprising:
 - a shaft defining a rod axis, and
 - a curved body comprising a piercing tip at a first region and a base coupled to the shaft at a second region of the curved body such that the base of the curved body is positioned in a first plane intersected by the rod axis of the shaft, and the piercing tip is positioned in a second plane intersected by the rod axis of the shaft;
 - a suture magazine retained within the housing and holding a set of sutures, each comprising a fastener end coupled to an anchor end;
 - a drive system that transforms a compressive force into rotation of the shaft of the suturing needle, wherein engagement of the drive system transitions the suturing needle between a first operation mode and a second operation mode,
 - wherein, in the first operation mode, the piercing tip of the curved body is rotated and engages the fastener end of at least one of the set of sutures as it exits the aperture of the housing for insertion into a tissue, and
 - wherein in the second operation mode the curved body displaces the anchor end of at least one of the set of sutures from the housing.
2. The system of claim 1, wherein the first plane is proximally displaced from the second plane, relative to the shaft of the suturing needle.
3. The system of claim 1, wherein the first plane is distally displaced from the second plane, relative to the shaft of the suturing needle.
4. The system of claim 1, the drive system is configured to transition the curved body of the suturing needle through greater than 180° of delivery rotation through the aperture of the housing.
5. The system of claim 1, wherein the curved body of the suturing needle comprises a helical body.
6. The system of claim 5, wherein the curved body of the suturing body comprises a straight portion coupling the piercing tip to the helical body.
7. The system of claim 5, wherein the curved body of the suturing needle comprises a recessed region facing a leading suture of the suture magazine during operation.
8. The system of claim 1, wherein the suture magazine comprises:

- a suture advancer comprising a first track coupled to the housing and supporting the set of sutures between a first end and a second end of the suture magazine, and a second track opposing the first track about the set of sutures, wherein the first end is near the aperture of the housing; and
- a biasing element coupled to the second track of the suture advancer and biasing the set of sutures toward the first end of the suture magazine, the biasing element contributing to an advancing mode of the suture magazine wherein, in the advancing mode, a leading suture of the set of sutures is displaced from the first end of the suture magazine by a compressive force applied by at least one of the biasing element and the suture advancer to the second track.
9. The system of claim 8, wherein the first track comprises a first set of teeth retaining and separating adjacent sutures of the set of sutures at a first side, and wherein the second track comprises a second set of teeth supporting the set of sutures at a second side in the advancing mode.
10. The system of claim 9, wherein the first set of teeth and the second set of teeth are complementary to surfaces of the set of sutures between the first track and the second track.
11. The system of claim 8, wherein the second track comprises a channel supporting the biasing element.
12. The system of claim 10, wherein the biasing element comprises a wave spring spanning the channel and preventing rocking between the first track and the second track.
13. The system of claim 1, wherein the drive system comprises: a hub, and a set of handles coupled at first regions of the set of handles to the hub and configured to transmit the compressive force toward the hub to induce actuation of the shaft of the suturing needle.
14. The system of claim 1, wherein in the first operation mode, the curved body is rotated in a first direction and the piercing tip engages the fastener end of a leading suture, and wherein in the second operation mode, the curved body is rotated in a second direction reversed from the first direction and the shoulder engages the anchor end of the leading suture to displace it from the aperture of the housing.
15. A system for suturing, the system comprising:
a housing having an aperture;
a suturing needle retained within the housing and comprising:
a shaft, and
a curved body comprising a piercing tip at a first region and a base coupled to the shaft at a second region of the curved body such that the base of the curved body is positioned in a first plane intersected by the rod axis of the shaft, and the piercing tip is positioned in a second plane different from the first plane;
- a suture magazine retained within the housing and holding a set of sutures, each comprising a fastener end coupled to an anchor end; and
- a drive system that transforms a force applied to the drive system into motion of the shaft of the suturing needle such that the piercing tip of the curved body engages the fastener end of a leading suture of the set of sutures and transmits the fastener end through the aperture of the housing for insertion into a tissue.
16. The system of claim 15, wherein the first plane is displaced from the second plane, relative to the shaft of the suturing needle, and wherein the drive system is configured to transition the curved body of the suturing needle through greater than 180° of delivery rotation through the aperture of the housing
17. The system of claim 15, wherein the curved body of the suturing needle comprises a helical body, and wherein the helical body comprises a recessed region facing the leading suture of the suture magazine.
18. The system of claim 15, wherein the suture magazine comprises a suture advancer comprising a first track coupled to an internal portion of the housing and supporting the set of sutures between a first end and a second end of the suture magazine, and a second track opposing the first track about the set of sutures and configured to move within the housing, wherein the first end is near the aperture of the housing.
19. The system of claim 18, wherein the first track comprises a first set of teeth retaining and separating adjacent sutures of the set of sutures at a first side, and wherein the second track comprises a second set of teeth supporting the set of sutures at a second side.
20. The system of claim 18, further comprising a biasing element coupled to the second track of the suture advancer and biasing the set of sutures toward the first end of the suture magazine, the biasing element contributing to an advancing mode of the suture magazine wherein, in the advancing mode, the leading suture of the set of sutures is displaced from the first end of the suture magazine by a compressive force applied by the biasing element to the second track, wherein the biasing element comprises a linear wave spring.

* * * * *

专利名称(译)	腹腔镜缝合装置，针头，缝合线和驱动系统		
公开(公告)号	US20200078007A1	公开(公告)日	2020-03-12
申请号	US16/682138	申请日	2019-11-13
发明人	O'HARA, DEREK M. JOHNS, DANIEL E. MEINZ, PETER J.		
IPC分类号	A61B17/04 A61B17/062 A61B17/06		
CPC分类号	A61B17/29 A61B17/06114 A61B2017/06042 A61B2017/06076 A61B34/30 A61B2017/00367 A61B2017/06009 A61B17/0625 A61B17/0482 A61B17/06166 A61B2017/047 A61B17/06066 A61B17/0485 A61B2017/0608 A61B17/0469 A61B17/06004 A61B2017/0496 A61B17/0487 A61B2017/00862 A61B2017/00477 A61B2017/00296 A61B2017/00004 A61B17/0491 A61B17/06128 A61B2034/302		
优先权	62/411830 2016-10-24 US 62/767964 2018-11-15 US		
外部链接	Espacenet USPTO		

摘要(译)

提供了用于在腹腔镜手术过程中使用的缝合装置的装置。一种缝合针，其包括形成杆轴的轴；和弯曲体，在第一端具有穿刺尖端，在第二端具有基部。臂，其从轴延伸到弯曲体的基部，使得弯曲体可绕轴旋转。该缝合装置包括壳体，缝合针，一个或多个缝合线，构造成保持一个或多个缝合线的缝合线盒以及驱动系统，由此驱动系统可以致动缝合针旋转，从而允许缝合针旋转。开车进出组织进行缝合。

