



US 20170086928A1

(19) **United States**

(12) **Patent Application Publication**

Auld et al.

(10) **Pub. No.: US 2017/0086928 A1**

(43) **Pub. Date: Mar. 30, 2017**

(54) **HYBRID ROBOTIC SURGERY WITH POWER ASSISTED MOTION**

(52) **U.S. Cl.**
CPC *A61B 34/30* (2016.02); *A61B 2034/302* (2016.02); *A61B 2017/00022* (2013.01)

(71) Applicant: **ETHICON ENDO-SURGERY, LLC,**
Guaynabo (PR)

(57) **ABSTRACT**

(72) Inventors: **Michael D. Auld,** Cincinnati, OH (US);
Kevin D. Felder, Cincinnati, OH (US);
Steven G. Hall, Cincinnati, OH (US)

Methods and devices are provided for performing robotic surgery. In general, a surgical system is provided including an electromechanical tool with a first mode of operation in which the electromechanical tool mimics movement of a controller, and a second mode of operation in which the tool mirrors movement of the controller. A hybrid surgical device is also provided including an adapter matable to a handle assembly such that the adapter is electronically coupled to a motor of the handle assembly and is configured to communicate with the motor. A robotic laparoscopic surgical device is also provided including a motion sensor configured to sense movement of an electromechanical tool and an electromechanical arm that assists movement of the tool. A robotic surgical device is also provided including an electromechanical driver associated with a trocar and being configured to rotate and to translate a tool disposed through a passageway.

(21) Appl. No.: **14/865,870**

(22) Filed: **Sep. 25, 2015**

Publication Classification

(51) **Int. Cl.**
A61B 34/30 (2006.01)

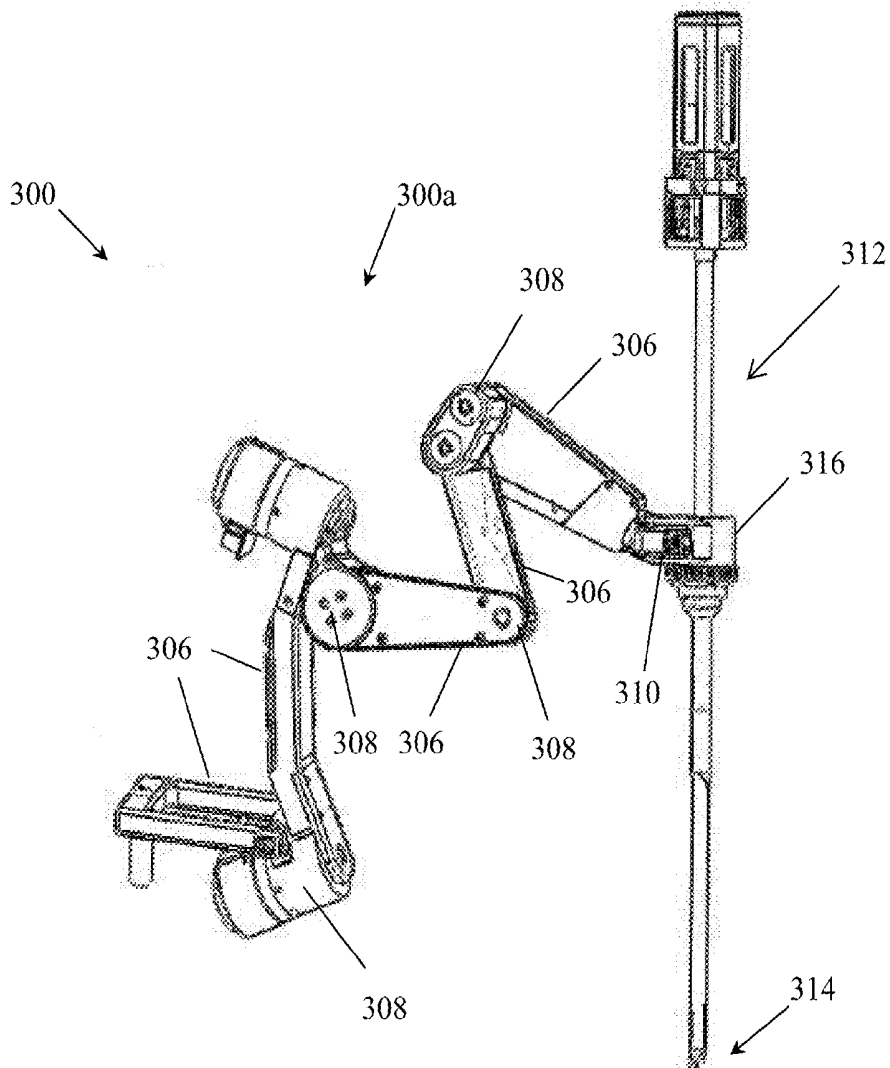

FIG. 1

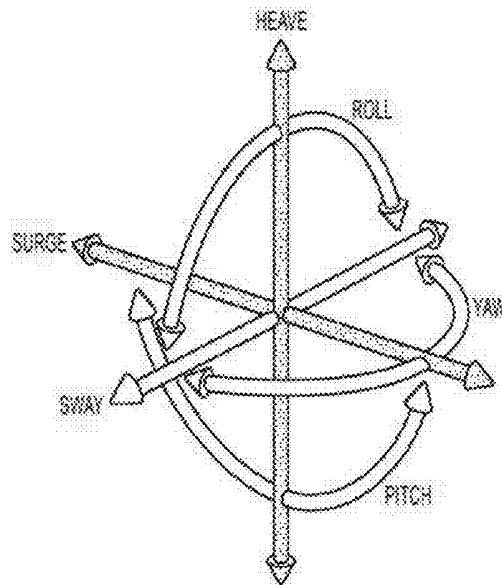

FIG. 2

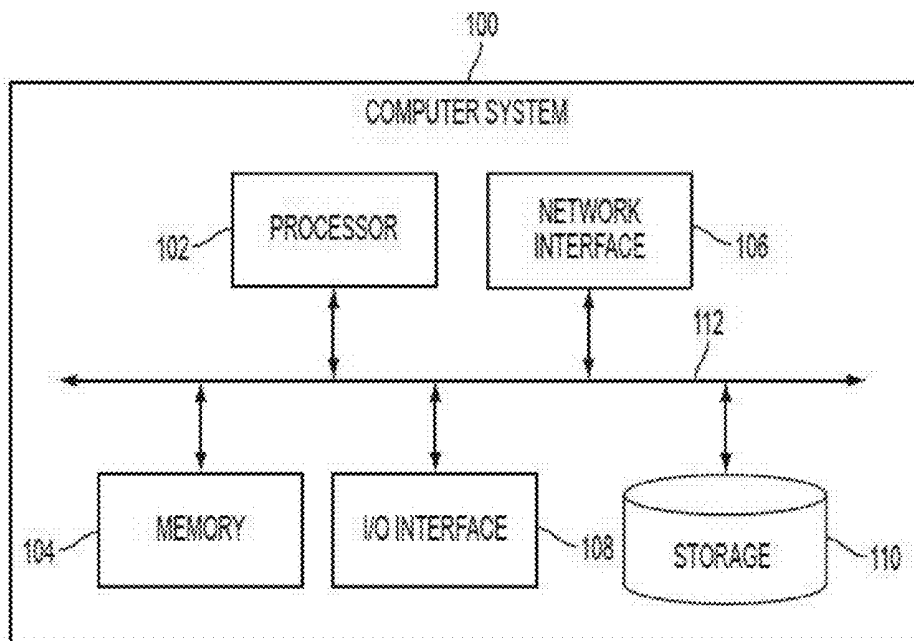

FIG. 3

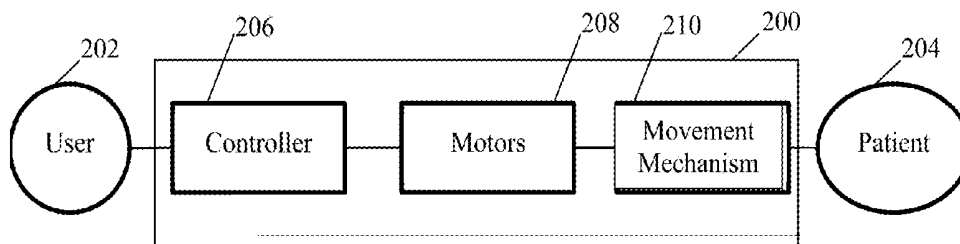

FIG. 4

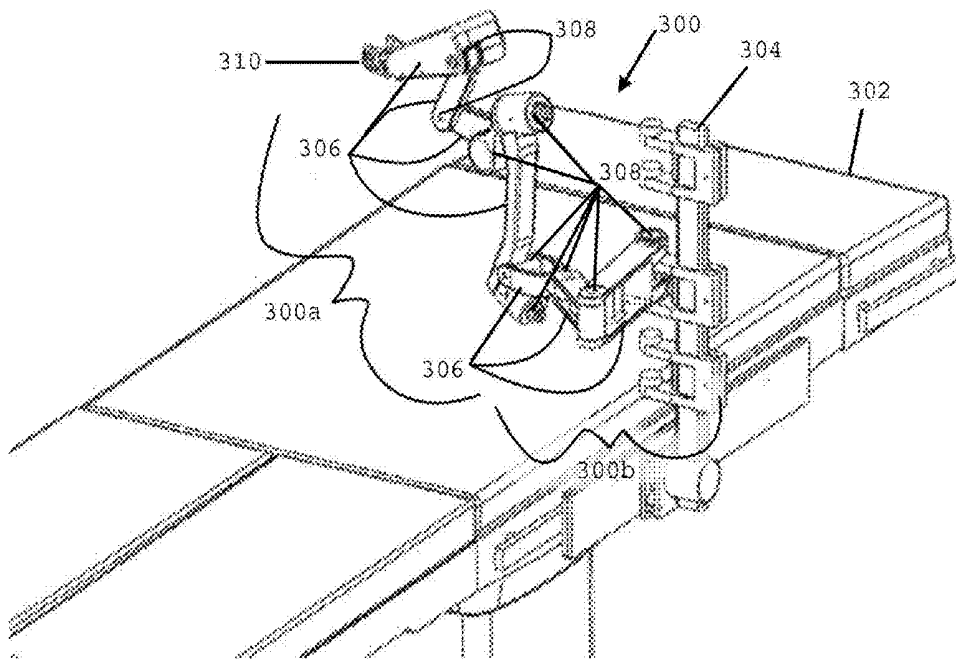

FIG. 5

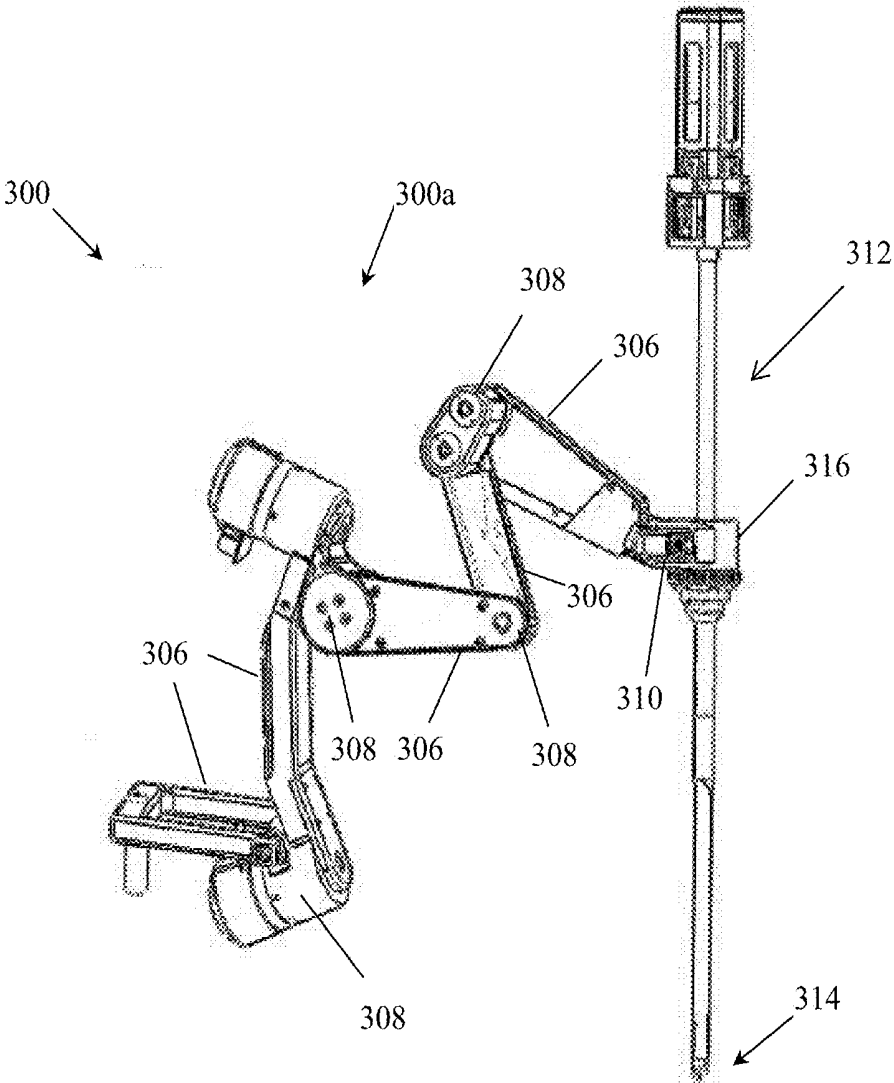

FIG. 6

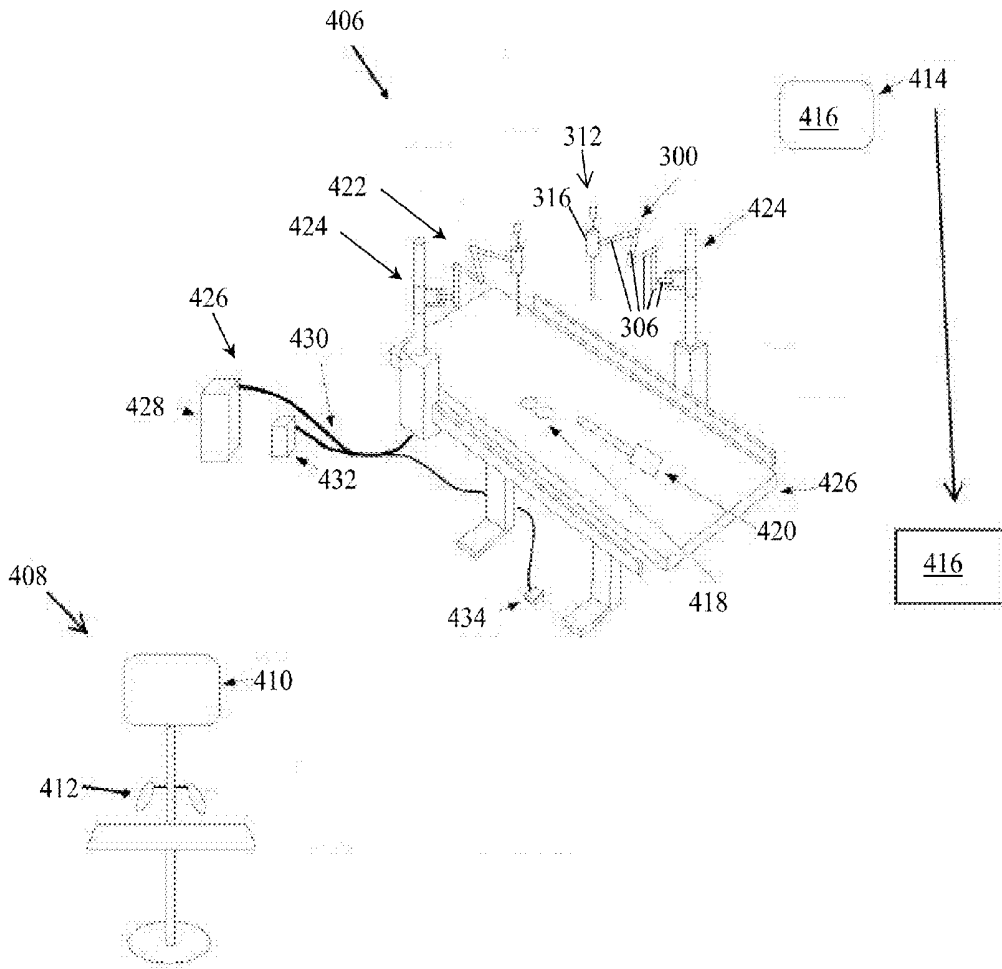

FIG. 7

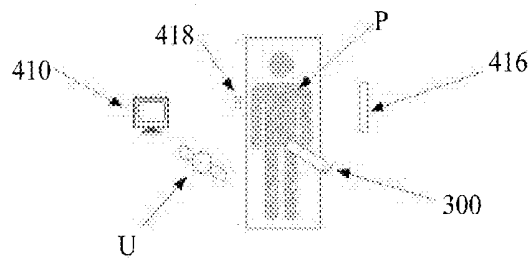

FIG. 8

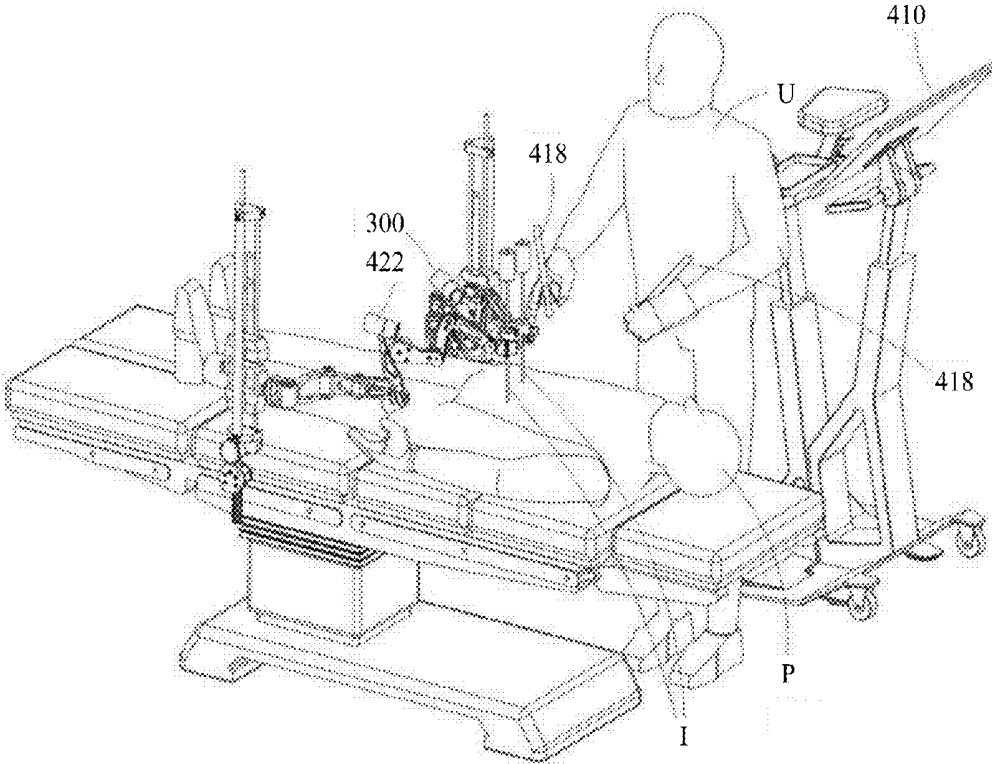

FIG. 9

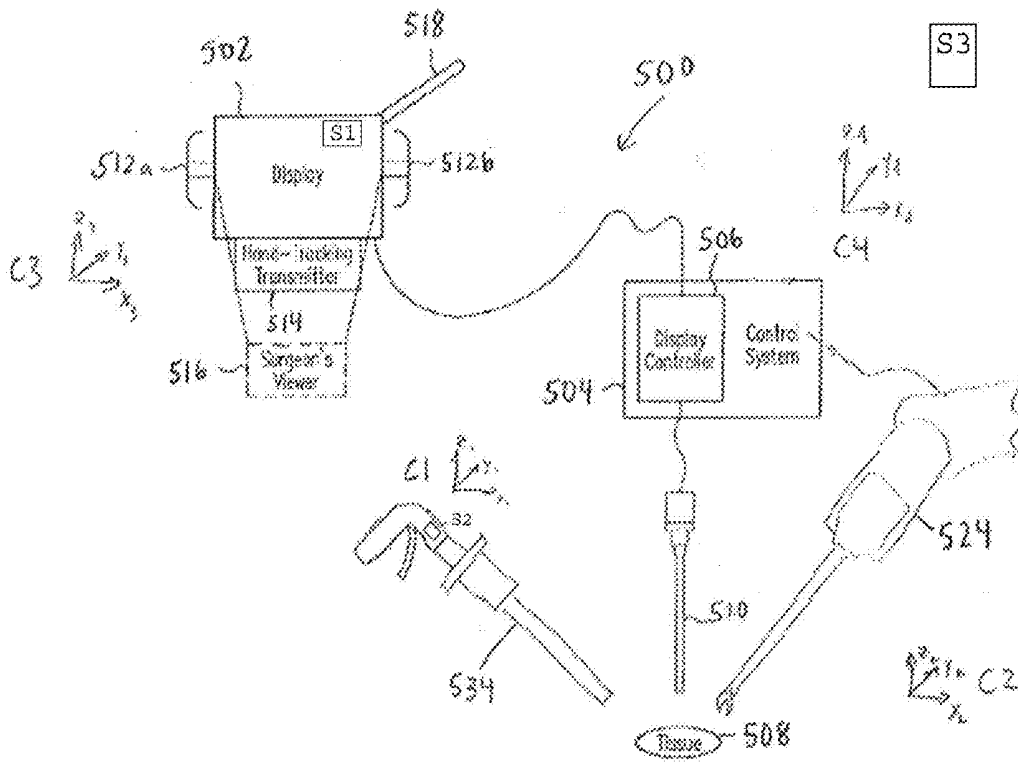

FIG. 10

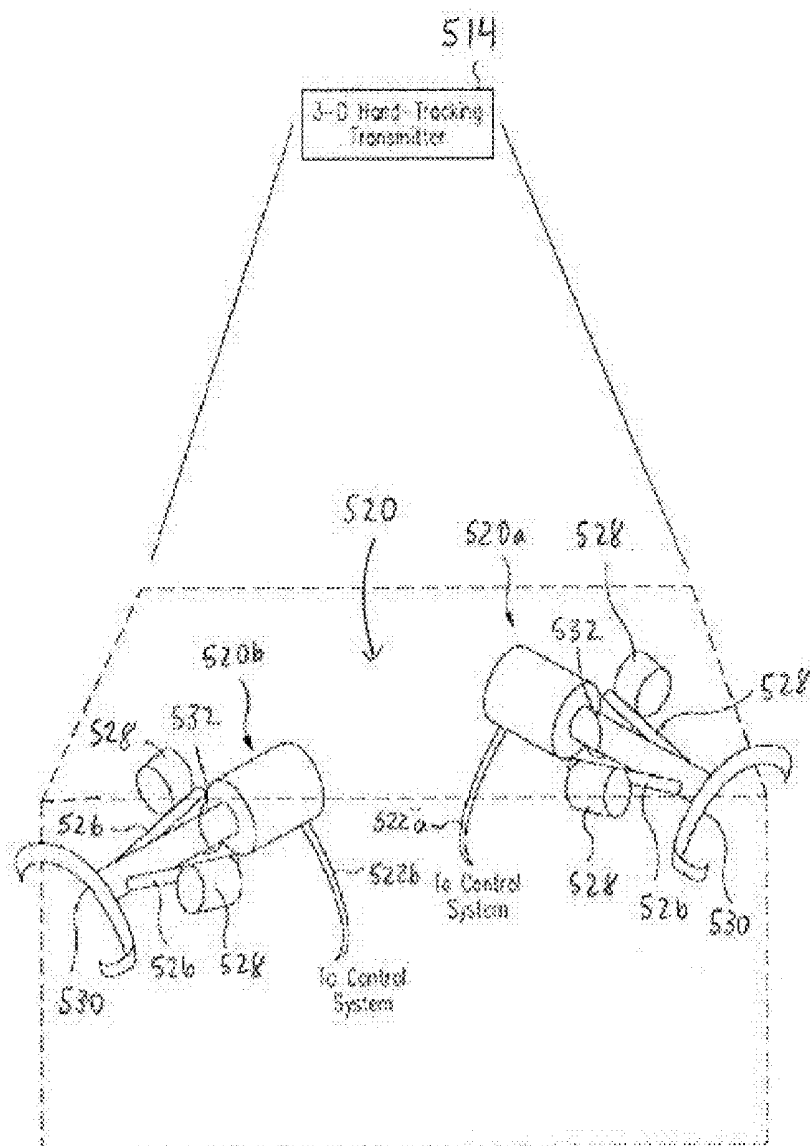

FIG. 11

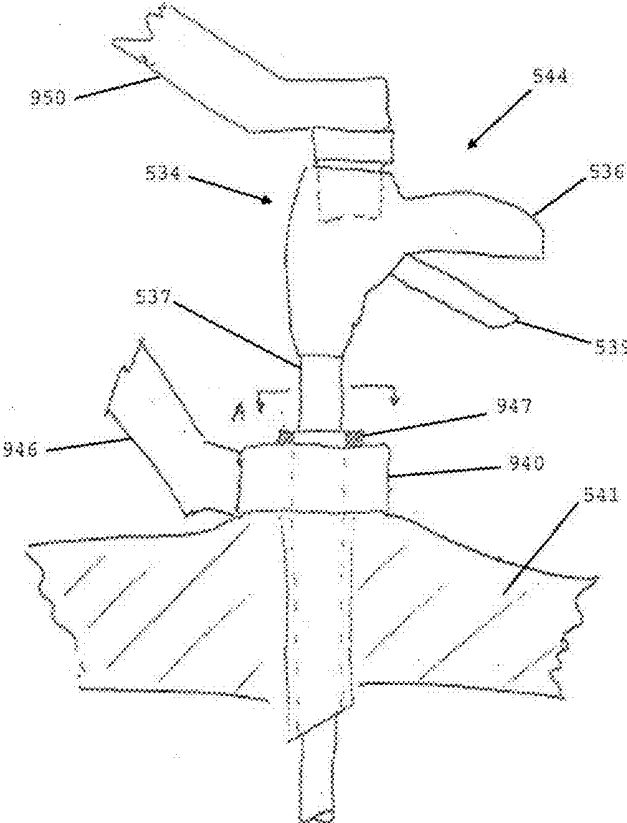

FIG. 12

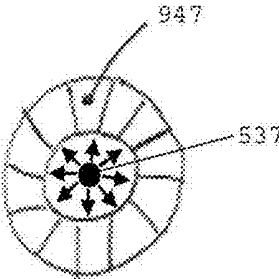
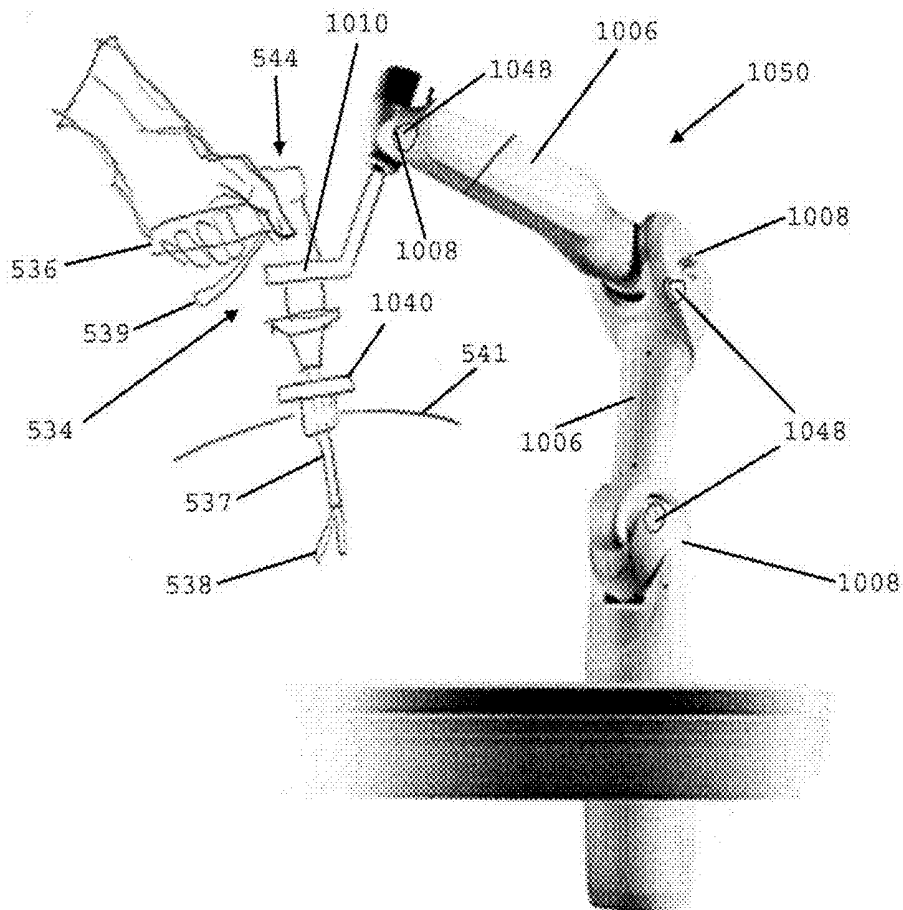

FIG. 13



HYBRID ROBOTIC SURGERY WITH POWER ASSISTED MOTION

FIELD OF THE INVENTION

[0001] Methods and devices are provided for performing robotic surgery, and in particular for performing hybrid surgery using both manually and robotically operated tools.

BACKGROUND OF THE INVENTION

[0002] Minimally invasive surgical (MIS) instruments are often preferred over traditional open surgical devices due to the reduced post-operative recovery time and minimal scarring. Laparoscopic surgery is one type of MIS procedure in which one or more small incisions are formed in the abdomen and a trocar is inserted through the incision to form a pathway that provides access to the abdominal cavity. The trocar is used to introduce various instruments and tools into the abdominal cavity, as well as to provide insufflation to elevate the abdominal wall above the organs. The instruments and tools can be used to engage and/or treat tissue in a number of ways to achieve a diagnostic or therapeutic effect. Endoscopic surgery is another type of MIS procedure in which elongate flexible shafts are introduced into the body through a natural orifice.

[0003] Various robotic systems have been developed to assist in MIS procedures. Robotic systems can allow for more intuitive hand movements by maintaining natural eye-hand axis. Robotic systems can also allow for more degrees of freedom in movement by including a "wrist" joint on the instrument, creating a more natural hand-like articulation. One drawback with robotic systems, however, is the loss of direct human contact with the tissue. There can be no true force feedback given to the surgeon. Another drawback is the high expense to manufacture such systems.

[0004] Accordingly, there remains a need for improved methods, systems, and devices for use in robotic surgery.

SUMMARY OF THE INVENTION

[0005] Various methods and devices are provided for performing robotic surgery.

[0006] In one embodiment, a robotic laparoscopic surgical device is provided and includes an electromechanical arm having an electromechanical tool coupled thereto, a motion sensor configured to sense movement of the electromechanical tool, and a control system configured to receive the sensed movement and to communicate a control signal to the electromechanical arm to cause movement of the arm that assists the movement of the tool.

[0007] In one embodiment, the motion sensor can be coupled to the electromechanical arm. In another embodiment, movement of the arm that assists the movement of the tool is proportional to the sensed movement of the electromechanical tool. In other aspects, the control system can be configured to send a control signal to the electromechanical arm that prevents movement of the arm and movement of the electromechanical tool. The device can also include a switch to disable the control signal. In other embodiments, the motion sensor can be disposed on the electromechanical tool. In yet another embodiment, the electromechanical tool can include an end effector having opposed jaws configured to engage tissue therebetween.

[0008] An embodiment of a laparoscopic surgical device is also provided that includes a manual tool assembly having

an end effector, a motion sensor coupled to the manual tool assembly and configured to sense movement of the manual tool assembly, and an electromechanical arm coupled to the manual tool assembly and configured to receive a movement signal from the motion sensor, and configured to provide power motion assistance to the manual tool assembly.

[0009] In one embodiment, the motion sensor can be coupled to the manual tool assembly. In other aspects, the power motion assistance of the electromechanical arm is proportional to the sensed movement of the manual tool assembly. In another embodiment, the electromechanical arm can be configured to selectively prevent movement of the manual tool assembly. The device can also include a switch to disable the power motion assistance. In yet another embodiment, the end effector can have opposed jaws configured to engage tissue therebetween.

BRIEF DESCRIPTION OF THE DRAWINGS

[0010] The invention will be more fully understood from the following detailed description taken in conjunction with the accompanying drawings, in which:

[0011] FIG. 1 is a graphical representation of terminology associated with six degrees of freedom;

[0012] FIG. 2 is a schematic view of one embodiment of a computer system;

[0013] FIG. 3 is a schematic view of one embodiment of a robotic surgical system configured to be operated by a user and to be used during performance of a surgical procedure on a patient;

[0014] FIG. 4 is a perspective view of one embodiment of an arm of a robotic surgical system, the arm being mounted to a surgical table;

[0015] FIG. 5 is a perspective view of an active portion of the arm of FIG. 4 having a tool coupled thereto;

[0016] FIG. 6 is a perspective view of another embodiment of a robotic surgical system;

[0017] FIG. 7 is a schematic view of the robotic surgical system of FIG. 6 in use during a surgical procedure performed on a patient;

[0018] FIG. 8 is a perspective view of the robotic surgical system of FIG. 6 in use during a surgical procedure performed on a patient;

[0019] FIG. 9 is a schematic and perspective view of another embodiment of a robotic surgical system having a manually operable instrument and a robotically controlled instrument;

[0020] FIG. 10 is a perspective view of one embodiment of a user input device positioned in a field generated by a transmitter of the robotic surgical system of FIG. 9;

[0021] FIG. 11 is a perspective view of the surgical instrument of FIG. 9 disposed within a trocar and coupled to a robotic arm;

[0022] FIG. 12 is a schematic cross-sectional view taken across line A of FIG. 11; and

[0023] FIG. 13 is a perspective view of the surgical instrument of FIG. 9 disposed within a trocar and coupled to a robotic arm.

DETAILED DESCRIPTION OF THE INVENTION

[0024] Certain exemplary embodiments will now be described to provide an overall understanding of the principles of the structure, function, manufacture, and use of the

devices and methods disclosed herein. One or more examples of these embodiments are illustrated in the accompanying drawings. Those skilled in the art will understand that the devices and methods specifically described herein and illustrated in the accompanying drawings are non-limiting exemplary embodiments and that the scope of the present invention is defined solely by the claims. The features illustrated or described in connection with one exemplary embodiment may be combined with the features of other embodiments. Such modifications and variations are intended to be included within the scope of the present invention.

[0025] Further, in the present disclosure, like-named components of the embodiments generally have similar features, and thus within a particular embodiment each feature of each like-named component is not necessarily fully elaborated upon. Additionally, to the extent that linear or circular dimensions are used in the description of the disclosed systems, devices, and methods, such dimensions are not intended to limit the types of shapes that can be used in conjunction with such systems, devices, and methods. A person skilled in the art will recognize that an equivalent to such linear and circular dimensions can easily be determined for any geometric shape. Sizes and shapes of the systems and devices, and the components thereof, can depend at least on the anatomy of the subject in which the systems and devices will be used, the size and shape of components with which the systems and devices will be used, and the methods and procedures in which the systems and devices will be used.

[0026] In general, methods and devices for performing hybrid robotic surgery are provided. In particular, the methods and devices disclosed herein allow an operator to perform a surgical procedure using a robotically controlled instrument, and to use a selectively manually operated surgical instrument. The robotic and manual instruments are capable of performing a variety of functions and the procedure can be selectively performed using an entirely manual operation of the instrument(s), a partially-manual and partially-powered operation of the instrument(s), and an entirely powered operation of instrument(s). Manually operated surgical instruments are further provided that are capable of receiving movement assistance from robotic arms during surgery. Robotic trocars are also provided that are capable of receiving instruments and providing controlled movement to those instruments within certain degrees of freedom.

TERMINOLOGY

[0027] There are a number of ways in which to describe the movement of a surgical system, as well as its position and orientation in space. One particularly convenient convention is to characterize a system in terms of its degrees of freedom. The degrees of freedom of a system are the number of independent variables that uniquely identify its pose or configuration. The set of Cartesian degrees of freedom is usually represented by the three translational or position variables, e.g., surge, heave, and sway, and by the three rotational or orientation variables, e.g., Euler angles or roll, pitch, and yaw, that describe the position and orientation of a component of a surgical system with respect to a given reference Cartesian frame. As used herein, and as illustrated in FIG. 1, the term “surge” refers to forward and backward movement, the term “heave” refers to movement up and

down, and the term “sway” refers to movement left and right. With regard to the rotational terms, “roll” refers to tilting side to side, “pitch” refers to tilting forward and backward, and “yaw” refers to turning left and right. In a more general sense, each of the translation terms refers to movement along one of the three axes in a Cartesian frame, and each of the rotational terms refers to rotation about one of the three axes in a Cartesian frame.

[0028] Although the number of degrees of freedom is at most six, a condition in which all the translational and orientation variables are independently controlled, the number of joint degrees of freedom is generally the result of design choices that involve considerations of the complexity of the mechanism and the task specifications. For non-redundant kinematic chains, the number of independently controlled joints is equal to the degree of mobility for an end effector. For redundant kinematic chains, the end effector will have an equal number of degrees of freedom in Cartesian space that will correspond to a combination of translational and rotational motions. Accordingly, the number of degrees of freedom can be more than, equal to, or less than six.

[0029] With regard to characterizing the position of various components of the surgical system and the mechanical frame, the terms “forward” and “rearward” may be used. In general, the term “forward” refers to an end of the surgical system that is closest to the distal end of the input tool, and when in use in a surgical procedure, to the end disposed within a patient’s body. The term “rearward” refers to an end of the surgical system farthest from the distal end of the input tool, and when in use, generally to the end farther from the patient.

[0030] The terminology used herein is not intended to limit the invention. For example, spatially relative terms, e.g., “superior,” “inferior,” “beneath,” “below,” “lower,” “above,” “upper,” “rearward,” “forward,” etc., may be used to describe one element’s or feature’s relationship to another element or feature as illustrated in the figures. These spatially relative terms are intended to encompass different positions and orientations of the device in use or operation in addition to the position and orientation shown in the figures. For example, if the device in the figures is turned over, elements described as “inferior to” or “below” other elements or features would then be “superior to” or “above” the other elements or features. Likewise, descriptions of movement along and around various axes include various special device positions and orientations. As will be appreciated by those skilled in the art, specification of the presence of stated features, steps, operations, elements, and/or components does not preclude the presence or addition of one or more other features, steps, operations, elements, components, and/or groups described herein. In addition, components described as coupled may be directly coupled, or they may be indirectly coupled via one or more intermediate components.

[0031] There are several general aspects that apply to the various descriptions below. For example, at least one surgical end effector is shown and described in various figures. An end effector is the part of a surgical instrument or assembly that performs a specific surgical function, e.g., forceps/graspers, needle drivers, scissors, electrocautery hooks, staplers, clip applicators/removers, suction tools, irrigation tools, etc. Any end effector can be utilized with the surgical systems described herein. Further, in exemplary

embodiments, an end effector can be configured to be manipulated by a user input tool. The input tool can be any tool that allows successful manipulation of the end effector, whether it be a tool similar in shape and style to the end effector, such as an input tool of scissors similar to end effector scissors, or a tool that is different in shape and style to the end effector, such as an input tool of a glove dissimilar to end effector graspers, and such as an input tool of a joystick dissimilar to end effector graspers. In some embodiments, the input tool can be a larger scaled version of the end effector to facilitate ease of use. Such a larger scale input tool can have finger loops or grips of a size suitable for a user to hold. However, the end effector and the input tool can have any relative size.

[0032] A slave tool, e.g., a surgical instrument, of the surgical system can be positioned inside a patient's body cavity through an access point in a tissue surface for minimally invasive surgical procedures. Typically, cannulas such as trocars are used to provide a pathway through a tissue surface and/or to prevent a surgical instrument or guide tube from rubbing on patient tissue. Cannulas can be used for both incisions and natural orifices. Some surgical procedures require insufflation, and the cannula can include one or more seals to prevent excess insufflation gas leakage past the instrument or guide tube. In some embodiments, the cannula can have a housing coupled thereto with two or more sealed ports for receiving various types of instruments besides the slave assembly. As will be appreciated by a person skilled in the art, any of the surgical system components disclosed herein can have a functional seal disposed thereon, therein, and/or therearound to prevent and/or reduce insufflation leakage while any portion of the surgical system is disposed through a surgical access port, such as a cannula. The surgical systems can also be used in open surgical procedures. As used herein, a surgical access point is a point at which the slave tool enters a body cavity through a tissue surface, whether through a cannula in a minimally invasive procedure or through an incision in an open procedure.

[0033] Computer Systems

[0034] The systems, devices, and methods disclosed herein can be implemented using one or more computer systems, which may also be referred to herein as digital data processing systems and programmable systems.

[0035] One or more aspects or features of the subject matter described herein can be realized in digital electronic circuitry, integrated circuitry, specially designed application specific integrated circuits (ASICs), field programmable gate arrays (FPGAs) computer hardware, firmware, software, and/or combinations thereof. These various aspects or features can include implementation in one or more computer programs that are executable and/or interpretable on a programmable system including at least one programmable processor, which can be special or general purpose, coupled to receive data and instructions from, and to transmit data and instructions to, a storage system, at least one input device, and at least one output device. The programmable system or computer system may include clients and servers. A client and server are generally remote from each other and typically interact through a communication network. The relationship of client and server arises by virtue of computer programs running on the respective computers and having a client-server relationship to each other.

[0036] The computer programs, which can also be referred to as programs, software, software applications, applica-

tions, components, or code, include machine instructions for a programmable processor, and can be implemented in a high-level procedural language, an object-oriented programming language, a functional programming language, a logical programming language, and/or in assembly/machine language. As used herein, the term "machine-readable medium" refers to any computer program product, apparatus and/or device, such as for example magnetic discs, optical disks, memory, and Programmable Logic Devices (PLDs), used to provide machine instructions and/or data to a programmable processor, including a machine-readable medium that receives machine instructions as a machine-readable signal. The term "machine-readable signal" refers to any signal used to provide machine instructions and/or data to a programmable processor. The machine-readable medium can store such machine instructions non-transitorily, such as for example as would a non-transient solid-state memory or a magnetic hard drive or any equivalent storage medium. The machine-readable medium can alternatively or additionally store such machine instructions in a transient manner, such as for example as would a processor cache or other random access memory associated with one or more physical processor cores.

[0037] To provide for interaction with a user, one or more aspects or features of the subject matter described herein can be implemented on a computer having a display device, such as for example a cathode ray tube (CRT) or a liquid crystal display (LCD) or a light emitting diode (LED) monitor for displaying information to the user and a keyboard and a pointing device, e.g., a mouse, a trackball, etc., by which the user may provide input to the computer. Other kinds of devices can be used to provide for interaction with a user as well. For example, feedback provided to the user can be any form of sensory feedback, such as for example visual feedback, auditory feedback, or tactile feedback; and input from the user may be received in any form, including, but not limited to, acoustic, speech, or tactile input. Other possible input devices include, but are not limited to, touch screens or other touch-sensitive devices such as single or multi-point resistive or capacitive trackpads, voice recognition hardware and software, optical scanners, optical pointers, digital image capture devices and associated interpretation software, and the like.

[0038] FIG. 2 illustrates one exemplary embodiment of a computer system **100**. As shown, the computer system **100** can include one or more processors **102** which can control the operation of the computer system **100**. "Processors" are also referred to herein as "controllers." The processor(s) **102** can include any type of microprocessor or central processing unit (CPU), including programmable general-purpose or special-purpose microprocessors and/or any one of a variety of proprietary or commercially available single or multi-processor systems. The computer system **100** can also include one or more memories **104**, which can provide temporary storage for code to be executed by the processor (s) **102** or for data acquired from one or more users, storage devices, and/or databases. The memory **104** can include read-only memory (ROM), flash memory, one or more varieties of random access memory (RAM) (e.g., static RAM (SRAM), dynamic RAM (DRAM), or synchronous DRAM (SDRAM)), and/or a combination of memory technologies.

[0039] The various elements of the computer system **100** can be coupled to a bus system **112**. The illustrated bus

system **112** is an abstraction that represents any one or more separate physical busses, communication lines/interfaces, and/or multi-drop or point-to-point connections, connected by appropriate bridges, adapters, and/or controllers. The computer system **100** can also include one or more network interface(s) **106**, one or more input/output (IO) interface(s) **108**, and one or more storage device(s) **110**.

[0040] The network interface(s) **106** can enable the computer system **100** to communicate with remote devices, e.g., other computer systems, over a network, and can be, for non-limiting example, remote desktop connection interfaces, Ethernet adapters, and/or other local area network (LAN) adapters. The IO interface(s) **108** can include one or more interface components to connect the computer system **100** with other electronic equipment. For non-limiting example, the IO interface(s) **108** can include high speed data ports, such as universal serial bus (USB) ports, 1394 ports, Wi-Fi, Bluetooth, etc. Additionally, the computer system **100** can be accessible to a human user, and thus the IO interface(s) **108** can include displays, speakers, keyboards, pointing devices, and/or various other video, audio, or alphanumeric interfaces. The storage device(s) **110** can include any conventional medium for storing data in a non-volatile and/or non-transient manner. The storage device(s) **110** can thus hold data and/or instructions in a persistent state, i.e., the value(s) are retained despite interruption of power to the computer system **100**. The storage device(s) **110** can include one or more hard disk drives, flash drives, USB drives, optical drives, various media cards, diskettes, compact discs, and/or any combination thereof and can be directly connected to the computer system **100** or remotely connected thereto, such as over a network. In an exemplary embodiment, the storage device(s) can include a tangible or non-transitory computer readable medium configured to store data, e.g., a hard disk drive, a flash drive, a USB drive, an optical drive, a media card, a diskette, a compact disc, etc.

[0041] The elements illustrated in FIG. 2 can be some or all of the elements of a single physical machine. In addition, not all of the illustrated elements need to be located on or in the same physical machine. Exemplary computer systems include conventional desktop computers, workstations, minicomputers, laptop computers, tablet computers, personal digital assistants (PDAs), mobile phones, and the like.

[0042] The computer system **100** can include a web browser for retrieving web pages or other markup language streams, presenting those pages and/or streams (visually, aurally, or otherwise), executing scripts, controls and other code on those pages/streams, accepting user input with respect to those pages/streams (e.g., for purposes of completing input fields), issuing HyperText Transfer Protocol (HTTP) requests with respect to those pages/streams or otherwise (e.g., for submitting to a server information from the completed input fields), and so forth. The web pages or other markup language can be in HyperText Markup Language (HTML) or other conventional forms, including embedded Extensible Markup Language (XML), scripts, controls, and so forth. The computer system **100** can also include a web server for generating and/or delivering the web pages to client computer systems.

[0043] In an exemplary embodiment, the computer system **100** can be provided as a single unit, e.g., as a single server, as a single tower, contained within a single housing, etc. The single unit can be modular such that various aspects thereof

can be swapped in and out as needed for, e.g., upgrade, replacement, maintenance, etc., without interrupting functionality of any other aspects of the system. The single unit can thus also be scalable with the ability to be added to as additional modules and/or additional functionality of existing modules are desired and/or improved upon.

[0044] A computer system can also include any of a variety of other software and/or hardware components, including by way of non-limiting example, operating systems and database management systems. Although an exemplary computer system is depicted and described herein, it will be appreciated that this is for sake of generality and convenience. In other embodiments, the computer system may differ in architecture and operation from that shown and described here.

[0045] Robotic Surgical Systems

[0046] The systems, devices, and methods disclosed herein can be implemented using a robotic surgical system. Various embodiments of robotic surgical systems are described in further detail in U.S. Pat. No. 8,831,782 filed Jul. 15, 2013 entitled "Patient-Side Surgeon Interface For A Teleoperated Surgical Instrument," Intl. Pat. Pub. No. WO2014151621 filed Mar. 13, 2014 entitled "Hyperdexterous Surgical System," Intl. Pat. Pub. No. WO2014151952 filed Mar. 13, 2014 entitled "Compact Robotic Wrist," and U.S. Pat. Pub. No. 2012/0158013 filed Dec. 17, 2010 entitled "Surgical System And Methods For Mimicked Motion," which are hereby incorporated by reference in their entireties.

[0047] As will be appreciated by a person skilled in the art, electronic communication between various components of a robotic surgical system can be wired or wireless. A person skilled in the art will also appreciate that all electronic communication in the system can be wired, all electronic communication in the system can be wireless, or some portions of the system can be in wired communication and other portions of the system can be in wireless communication.

[0048] FIG. 3 schematically illustrates a robotic surgical system **200** configured to be used by a user **202** (e.g., a surgeon, a surgical assistant, etc.) during performance of a surgical procedure on a patient **204**. In this illustrated embodiment, the robotic surgical system **200** includes a controller **206**, one or more motors **208**, and a movement mechanism **210**. The controller **206** can be configured to receive an input from the user **202** requesting movement, relative to the patient **204**, of a surgical instrument coupled to the movement mechanism **210**. The controller **206** can be configured to cause the motors **208** to drive movement of the movement mechanism **210**, thereby causing the movement of the surgical instrument as requested by the user **202**. The robotic surgical system **200** can include a plurality of motors, or it can include a single motor. Similarly, the robotic surgical system **200** can include a single controller and a single movement mechanism, or the robotic surgical system can include a plurality of controllers and/or a plurality of movement mechanisms.

[0049] In an exemplary embodiment, the movement mechanism **210** includes an arm. The arm can be configured to move so as to cause movement of a surgical instrument coupled thereto in any one or more of the three translational directions (surge, heave, and sway) and in any one or more of the three rotational directions (roll, pitch, and yaw) in response to control by the controller **206**. In an exemplary

embodiment, the arm is configured to provide a plurality of degrees of freedom. More than six degrees of freedom can be provided in a variety of ways, as mentioned above and as will be appreciated by a person skilled in the art. In general, the arm can include a mechanical member configured to move in response to an input received by the system **200** from the user **202**. The user's input can be configured to cause the controller **206** to transmit an electronic signal to the motors **208** that causes the motors **208** to provide a force (e.g., torque) to the arm, thereby causing movement of the arm. The arm can include a plurality of members jointed together, which can facilitate movement of the arm in a plurality of degrees of freedom via bending, twisting, etc. at one or more of the joints.

[0050] In an exemplary embodiment, the arm is an electromechanical arm. The electromechanical arm can include one or more mechanical members configured to move in response to an electronic input. Examples of mechanical members that can form the arm include elongate shafts, coupling mechanisms configured to removably and replaceably couple a surgical instrument to the arm, and joints (e.g., hinges, gimbals, etc.). The coupling mechanism can be, for example, clips, magnets, snap fit mechanisms, shaped members configured to seat an instrument therein by interference fit or press fit, clamps, protrusions configured to be seated in corresponding depressions formed in a surgical instrument, depressions configured to receive therein corresponding protrusions extending from a surgical instrument, etc.

[0051] FIGS. **4** and **5** illustrate one embodiment of an arm **300** in the form of an electromechanical arm. The arm **300** in FIG. **4** is shown mounted to a surgical table **302** using a frame **304**, however the arm **300** can be mounted to any of a variety of stationary items, a wall, a table, a cart, the ceiling, etc., in any of a variety of ways to help stabilize the arm **300** for use during a surgical procedure. The illustrated arm **300** includes an active portion **300a** configured to be actively controlled, e.g., configured to move in response to an electronic input, and a passive portion **300b** configured to be passively controlled, e.g., configured to move in response to manual movement thereof. The passive portion **300b** can lack motors or other electrical features, while the active portion **300a** can include motors and other electrical features that are associated with the joints to facilitate electronic control thereof. In at least some embodiments, an arm can lack a passive portion so as to be configured to be entirely actively controlled. While the active and passive portions **300a**, **300b** are sometimes referred to herein as components of a single arm, a person skilled in the art will appreciate that the active portion **300a** and the passive portion **300b** can be separate arms that are matable to each other.

[0052] As shown, the arm **300** can include a plurality of mechanical members **306**, a plurality of joints **308**, and a coupling mechanism **310**. Adjacent ones of the mechanical members **306** can be attached together by a joint **308**. In this embodiment, the active portion **300a** of the arm **300** includes four mechanical members **306** and five joints **308**, the passive portion **300b** of the arm **300** includes three mechanical members **306** and three joints **308**, and the arm **300** includes another joint **308** between the active and passive portions **300a**, **300b**. A person skilled in the art will appreciate that the arm can have any number of mechanical members and associated joints in its active and passive portions.

[0053] FIG. **5** illustrates the active portion of the arm, and as shown it can be configured to removably and replaceably couple to a surgical instrument **312** via the coupling mechanism **310**. A distal end **314** of the instrument **312** can be configured to be advanced into a body of a patient, e.g., through an incision, through a natural orifice, etc. The instrument's distal end **314** can be configured to facilitate performance of a surgical procedure within the patient. For example, the instrument's distal end **314** can include an end effector, e.g., forceps/graspers, needle drivers, scissors, electrocautery hooks, staplers, clip applicators/removers, suction tools, irrigation tools, etc. As in this illustrated embodiment, the instrument **312** can be advanced into a patient's body through a cannula **316** that is mated to the coupling mechanism **310**.

[0054] Aspects of the arm **300** and the frame **304** are further described in previously mentioned Intl. Pat. Pub. No. WO2014151621 filed Mar. 13, 2014 entitled "Hyperdexterous Surgical System" and Intl. Pat. Pub. No. WO2014151952 filed Mar. 13, 2014 entitled "Compact Robotic Wrist," which are incorporated herein by reference in their entireties.

[0055] FIGS. **6-8** illustrate the arm **300** coupled to a surgical table. As shown in FIGS. **6** and **7**, the arm **300** can be included in a robotic surgical system **406** configured to facilitate performance of a surgical procedure on a patient P. FIG. **8** shows an example of the system **406** in use. As in this illustrated embodiment, the system **406** can include a user interface sub-system **408** that can include at least one display **410** configured to display information thereon to a user U, at least one user input device **412** configured to receive a user input to control movement of the arm **300**, a visualization system **414** that can include at least one display **416** configured to display thereon image(s) of a surgical procedure being performed using the system **406**, a freely movable user input device **418** (shown as pinchers in this illustrated embodiment) configured to receive a user input to control movement of the arm **300** and configured to be freely moved around by the user U (e.g., handheld and moved around any space in or near an operating room, etc.), an additional arm **422** that can be configured and used similar to the arm **300**, and a control system **426** configured to facilitate control of the arms **300**, **422** by transferring user inputs received from the user input devices **412**, **418**, e.g., manual movement of a user input device, movement indicated by touch on a touch screen, etc., to one or both of the arms **300**, **422** as appropriate. The system **406** in this illustrated embodiment includes two arms **300**, **422**, but it can include any number of arms, e.g., three, four, etc. The display **410** of the user interface sub-system **408** can be configured as a user input device, e.g., as a touchscreen configured to receive user touch input thereon. The user interface sub-system **408** can be in the same room as the patient P, or it can be in a different room.

[0056] The control system **426** can include at least one computer **428**, one or more cables **430**, and at least one power supply **432**. The computer **428** can include at least one processor (not shown). As mentioned above, some embodiments of control systems can be at least partially wireless, in which case at least some of the cables **430** need not be present. The robotic surgical system **406** can include at least one foot pedal **434** coupled to the computer **428** via one of the cables **430**, which can allow the foot pedal **434** to serve as a user input device.

[0057] The robotic surgical system 406 can further include a frame 424 for each of the arms 300, 422. The frames 424 in the illustrated embodiment are each mounted to a surgical table 426, but as mentioned above, frames can be mounted elsewhere. The frames 424 in the illustrated embodiment each include a vertical extension movably coupled to a rail mounted to the table 426. The vertical extension can be configured to move along the rail, thereby facilitating positioning of the arms 300, 422 relative to the patient P.

[0058] One or more manually operated surgical instruments 420, e.g., instruments not under the control of the robotic surgical system 406, can also be used to perform the surgical procedure being performed on the patient P.

[0059] Aspects of the robotic surgical system 406 are further described in previously mentioned Intl. Pat. Pub. No. WO2014151621 filed Mar. 13, 2014 entitled "Hyperdexterous Surgical System."

[0060] FIG. 9 illustrates another embodiment of a robotic surgical system 500. In this embodiment, the robotic surgical system 500 includes a display 502 and a control system 504 configured to be in electronic communication with the display 502. The display 502 and the control system 504 are shown in wired electronic communication, but the electronic communication can be wireless. The control system 504 can include a computer system having a display controller 506 configured to facilitate the display of images on the display 502, such as images of tissue 508 visualized by an endoscope 510 coupled to the control system 504. The display 502 can include handles 512a, 512b configured to facilitate manual movement of the display 502, a hand-tracking transmitter 514 configured to generate a field (e.g., an electromagnetic field, an optical field (e.g., light beams), etc.), a surgeon's viewer 516 (e.g., glasses, etc.) configured to facilitate three-dimensional (3-D) viewing of 3-D images shown on the display 502, and a boom 518 configured to mount the display 502 to a stable surface (e.g., a wall, a table, etc.). The display 502 can be configured to show two-dimensional (2-D) and/or 3-D images.

[0061] Movement of a user-controlled master tool 520 in a field generated by the transmitter 514 can be configured to provide sensed spatial position and orientation information in a 3-D coordinate system, as shown in FIG. 10. The master tool 520 can be configured to transmit the spatial position and orientation information to the control system 504, such as by cables 522a, 522b or using a wireless transmission. The control system 504, e.g., a processor thereof, can be configured to receive the transmitted spatial position and orientation information and, in response thereto, it can cause a slave tool 524 to move in accordance with the user's movement of the master tool 520. The robotic surgical system 500 can thus allow control of the slave tool 524 via the master tool 520. The master tool 520 in this illustrated embodiment includes first and second master tool grips 520a, 520b that each include a plurality of levers 526, a plurality of finger loops 528, a palm rest 530, and a mode control button 532, but the master tool 520 can have a variety of other configurations, as will be appreciated by a person skilled in the art. The robotic surgical system 500 can include any number of master tools and any number of slave tools each configured to be controlled by the master tool(s).

[0062] One or more manually operated surgical instruments 534 can be used to manipulate the tissue 508 in addition to the slave tool 524 that can manipulate the tissue 508.

[0063] FIG. 9 illustrates first, second, third, and fourth coordinate systems C1, C2, C3, C4 representing local coordinates that specify the respective position and orientation of the portion of the system 500 with which they are associated. The first coordinate system C1 is associated with the manually operated surgical instrument 534. The second coordinate system C2 is associated with the slave tool 524. The third coordinate system C3 is associated with a user (not shown) visualizing the display 502, and hence also with the master tool 520 configured to be manipulated by the user. The fourth coordinate system C4 is associated with the control system 504, and hence also with images that the control system 504 and the display controller 506 cause to be displayed on the display 502. In general, the control system 504 can be configured to transfer the third coordinate system C3 into the second coordinate system C2, e.g., transfer movement of the master tool 520 to movement of the slave tool 524. Mapping can be accomplished by, for example, an algorithm such as the Jacobian Matrix.

[0064] First, movement of the master tool 520 in the field generated by the transmitter 514, as discussed above, can be mapped into 3-D coordinates within the third coordinate system C3. For example, if the user is holding the master tool 520, e.g., one of the first and second master tool grips 520a, 520b, in one of his/her hands and moves that hand to his/her right, thereby moving the held master tool 520 to the right, this movement will be mapped into 3-D coordinates X3, Y3, Z3 within the third coordinate system C3. These movement coordinates can be communicated to the control system 504. The control system 504 can be configured to correspondingly transfer this movement from the third coordinate system C3 into the second coordinate system C2. For example, the control system 504 can transfer the 3-D coordinates X3, Y3, Z3 of the third coordinate system C3 into 3-D coordinates X2, Y2, Z2 of the second coordinate system C2. The control system 504 can then cause a working end of the slave tool 524 to move to the right by moving the slave tool 524 to the newly translated 3-D coordinates X2, Y2, Z2 of the second coordinate system C2. As the coordinates in the third coordinate system C3 change in coordination with movement of the master tool, the coordinates in the second coordinate system C2 will likewise simultaneously change, thereby causing the slave tool to move in coordination with the master tool. Thus the slave tool 524 effectively mimics the movement of the master tool 520. This movement is referred to herein as mimicked movement or motion. If the master tool 520 moves to the right, the slave tool 524 will move to the right, mimicking the movement. This movement can be accomplished by the control system 504 causing an arm to which the slave tool 524 is coupled, similar to the arms discussed herein, to move. The control system 504 and the display controller 506 can be configured to orient an image in the display 502 to the third coordinate system C3.

[0065] Aspects of the robotic surgical system 500 are further described in previously mentioned U.S. Pat. No. 8,831,782 filed Jul. 15, 2013 entitled "Patient-Side Surgeon Interface For A Teleoperated Surgical Instrument," which is incorporated herein by reference.

[0066] Assisted Movement

[0067] The positioning of manually operated surgical instruments used in minimally invasive surgery is commonly performed by entirely-manual movement of a surgical instrument by a user. However, movement of an instrument will encounter varying degrees of resistance from the

surrounding environment. For example, movement of an end effector to grasp and push or pull tissue of a patient can encounter resistance to such movement. Additionally, instruments can encounter resistance from the body wall of the patient and/or the trocar. Thus a user may be required to apply significant manual force to the handle to cause the end effector to move within the patient against any encountered resistance. Additionally, a user may wish to keep an instrument in a selected location. However, this may require a user to constantly and manually apply a force to the handle to maintain a position of the end effector within the body cavity. Finally, depending on the surgery being performed by a user, there may be selected motions of the instrument that are not desirable in the surgery. For example, a user may desire to prevent the instrument from penetrating too deep into a patient's inner tissue or may wish to prevent movement of an instrument in a certain direction. But during entirely-manual movement of an instrument, the user must continually apply force to prevent any selected motions of the instrument that are not desirable.

[0068] This required force can lead to greater fatigue and imprecise movements by a user of a manually operated surgical instrument. Providing supplemental force to instruments that enhances the manual movement of the instruments or restricts movement of the instruments when desired can assist a user in making more precise movements and can reduce fatigue during operations. Thus an electromechanical arm is provided for providing power motion assistance to a manually operated instrument coupled to the arm. It is also beneficial to have a motion sensor coupled to the instrument and/or the electromechanical arm to detect any motion of the instrument and/or arm and to be able to provide this information to a control system. The control system can be configured to provide information to the robotic arm to cause the robotic arm to assist the user in moving the instrument in the desired direction, as detected by the sensor.

[0069] An exemplary embodiment of a robotic arm configured to provide power motion assistance (i.e. "power steering") is shown in FIG. 11. A person skilled in the art will appreciate that the following is for illustrative purposes and these techniques can be applied to any and all of the instruments and devices discussed throughout. As shown, the surgical instrument 534 is passed through a trocar 940 which is disposed through the patient's body wall 541. A distal end effector on the instrument 534 is disposed within a body cavity in a patient. A robotic arm 946 is coupled to the trocar 940, and the trocar 940 includes a sensor ring 947. The sensor ring 947 can be elastically coupled to or formed on or within a proximal end of the trocar 947. The elongate shaft 537 of the instrument 534 can pass through both the trocar 940 and the sensor ring 947. As a user moves the instrument 534, the sensor ring 947 is configured to detect the movement of the elongate shaft 537. For example, the sensor ring 947 can be a force sensor ring or torus that contains a plurality of sensor elements that detect the direction and magnitude of force a user applies to the elongate shaft 537 as the elongate shaft 537 is moved relative to the force sensor ring 947, as shown in FIG. 12. A person skilled in the art will appreciate that the force sensor ring 947 may be made of any of a known number of medical grade materials.

[0070] Data regarding the movement of the elongate shaft 537, such as the direction and magnitude of force, can be sent by the sensor ring 947 and can be received by a control

system, such as the control system 504 in FIG. 9. The control system can send the data as a control signal to the robotic arm 946, which can receive the control signal. The robotic arm 946 can then cause rotation of the trocar 940 based on the control signal. This rotation can be proportional and directionally-related to the movement of the elongated shaft 537 by the user. For instance, the robotic arm 946 can move the trocar 947 in the direction and in proportion to the detected magnitude and direction of the movement of the elongated shaft 537 by the user.

[0071] The instrument 534 can be coupled to another robotic arm 950. Robotic arm 950 can be coupled to the instrument 534, for example at its proximal end. Robotic arm 950 can include sensors (not shown), such as torque sensors, in the arm joints of the robotic arm 950. The sensors can detect movement of the instrument 534. For example, the sensors 948 can detect longitudinal axial translation of the elongated shaft 537, rotation of the shaft 537, and angular movement of the shaft 537. As with the data above, this data can be received by a control system, for example the control system 504 of FIG. 9. The robotic arm 950 can receive a control signal from the control system regarding movement of the instrument 534. Based on this received control signal, the robotic arm 950 can apply force to the instrument 534. The applied force can be proportional to the detected movement. For example, the robotic arm 950 can receive a control signal regarding the detected magnitude and direction of the movement of the elongated shaft 537 by the user. The robotic arm 950 can then apply supplemental force to the proximal end of the instrument 534 in the direction and in proportion to the detected movement of the elongated shaft 537. With reference to the degrees of freedom set forth in FIG. 1, the movement can include any and/or all six degrees of freedom and any combination thereof. In this way, a user can experience a reduced need to apply manual force because the robotic arms 946, 950 can act to orient the trocar 940 and/or the instrument 534 to assist with movement of the instrument 534.

[0072] When a user stops moving the instrument 534, robotic arm 946 can maintain the trocar 940 in place, and/or robotic arm 950 maintain the instrument 534 in its current position to prevent the user from having to manually maintain the position.

[0073] The robotic arms 946, 950 can also act to restrict movement of the instrument 534 within one or more degrees of freedom as selected by the user. With reference to the degrees of freedom set forth in FIG. 1, a user can specify through the control system one or more degrees of freedom within which movement can be restricted, and the control system can send a control signal to robotic arm 946 and/or robotic arm 950. Robotic arm 946 and/or robotic arm 950 can act to restrict movement of the trocar 940 or instrument 534 in the selected degree(s) of freedom while still allowing assisted movement in the remaining degrees of freedom.

[0074] In use, a user can move the instrument 534 by movement of the handle 536, which is translated to movement of the end effector through the elongate shaft 537. Sensors on robotic arm 950 and/or the sensor ring 947 can detect movement of the instrument 534 and can communicate that movement to the control system. The control system can subsequently send a control signal to one or both robotic arms 946, 950. The control signal can cause propor-

tional assisted movement by the robotic arm 950 coupled to the instrument 534 and/or by the robotic arm 946 coupled to the trocar 940.

[0075] FIG. 13 illustrates another embodiment of a robotic arm 1050 that is coupled to the surgical instrument 534 such that the robotic arm 1050 assists the user's manual movement of the instrument 534. Again, a person skilled in the art will appreciate that the following is for illustrative purposes and that these techniques can be applied to any and all of the instruments and devices discussed throughout. As with the arm 300 discussed previously, the robotic arm 1050 can include a plurality of mechanical members 1006, a plurality of joints 1008, and a coupling mechanism 1010. The robotic arm 1050 can contain one or more sensors. For example, the arm 1050 can contain force and position sensors 1048 in one or more of the arm joints 1008 of the robotic arm 1050. The robotic arm 1050 can be coupled to the instrument 534 by the coupling mechanism 1010 such that the robotic arm 1050 does not interfere with the user's grip on the instrument 534. In the illustrated embodiment, the coupling mechanism 1010 is coupled to the instrument 534 on the body 544 at a location distal of the handle 536 and the trigger 539. The coupling mechanism 1010 can be in the form of a ring that seats the body 544, or it can engage the body using various mating techniques. In use, the force sensors 1048 can sense the direction and magnitude of movement of the instrument 534 by the user. The elongated shaft 537 can pass through a trocar 1040, which can be non-robotic or robotic, to position the end effector 538 within the body cavity of the patient.

[0076] The sensors 1048 in the robotic arm 1050 can serve both to detect the direction and magnitude of force the user applies to the elongate shaft 537, including longitudinal axial translation of the elongated shaft 537. This data can be received by a control system, such as the control system 504 of FIG. 9. The control system can then provide a control signal to the robotic arm 1050 based on the received sensor data, and the robotic arm 1050 can provide proportional movement assistance to the user during the user's manual manipulation of the instrument 534. For instance, the robotic arm 1050 can provide supplemental force through the point of coupling between the robotic arm 1050 and the instrument 534 distally from the handle 536 and trigger 539 of the instrument 534.

[0077] As with the robotic arms 946 and 950, when a user stops moving the instrument 534, robotic arm 1050 can maintain the instrument 534 in a fixed position to prevent the user from having to manually maintain the position. The robotic arm 1050 can also act to restrict movement of the instrument 534 within one or more degrees of freedom as selected by the user. For example, a user may select one or more degrees of freedom as discussed above with respect to FIG. 1. The user can select the degrees of freedom to be restricted through the control system, and the control system can send a control signal to the robotic arm 1050. The robotic arm 1050 can act to restrict movement of the instrument 534 in the selected degrees of freedom while still allowing assisted movement in the remaining degrees of freedom.

[0078] In use, the robotic arm 1050 can be coupled to the instrument 534. A user can move the instrument 534 by movement of the handle 536. Sensors 1048 coupled to the instrument 534 can detect the movement of the instrument 534 and communicate that movement to a control system, which can subsequently send a control signal to the robotic

arm 1050. The control signal can cause proportional assisted movement by the robotic arm 1050 of the instrument 534.

[0079] The devices disclosed herein can also be designed to be disposed of after a single use, or they can be designed to be used multiple times. In either case, however, the device can be reconditioned for reuse after at least one use. Reconditioning can include any combination of the steps of disassembly of the device, followed by cleaning or replacement of particular pieces and subsequent reassembly. In particular, the device can be disassembled, and any number of the particular pieces or parts of the device can be selectively replaced or removed in any combination. Upon cleaning and/or replacement of particular parts, the device can be reassembled for subsequent use either at a reconditioning facility, or by a surgical team immediately prior to a surgical procedure. Those skilled in the art will appreciate that reconditioning of a device can utilize a variety of techniques for disassembly, cleaning/replacement, and reassembly. Use of such techniques, and the resulting reconditioned device, are all within the scope of the present application.

[0080] Preferably, components of the invention described herein will be processed before use. First, a new or used instrument is obtained and if necessary cleaned. The instrument can then be sterilized. In one sterilization technique, the instrument is placed in a closed and sealed container, such as a plastic or TYVEK bag. The container and instrument are then placed in a field of radiation that can penetrate the container, such as gamma radiation, x-rays, or high energy electrons. The radiation kills bacteria on the instrument and in the container. The sterilized instrument can then be stored in the sterile container. The sealed container keeps the instrument sterile until it is opened in the medical facility.

[0081] Typically, the device is sterilized. This can be done by any number of ways known to those skilled in the art including beta or gamma radiation, ethylene oxide, steam, and a liquid bath (e.g., cold soak). An exemplary embodiment of sterilizing a device including internal circuitry is described in more detail in U.S. Pat. Pub. No. 2009/0202387 filed Feb. 8, 2008 and entitled "System And Method Of Sterilizing An Implantable Medical Device." It is preferred that device, if implanted, is hermetically sealed. This can be done by any number of ways known to those skilled in the art.

[0082] One skilled in the art will appreciate further features and advantages of the invention based on the above-described embodiments. Accordingly, the invention is not to be limited by what has been particularly shown and described, except as indicated by the appended claims. All publications and references cited herein are expressly incorporated herein by reference in their entirety.

What is claimed is:

1. A robotic laparoscopic surgical device, comprising: an electromechanical arm having an electromechanical tool coupled thereto; a motion sensor configured to sense movement of the electromechanical tool; a control system configured to receive the sensed movement and to communicate a control signal to the electromechanical arm to cause movement of the arm that assists the movement of the tool.
2. The device of claim 1, wherein the motion sensor is coupled to the electromechanical arm.

3. The device of claim 1, wherein movement of the arm that assists the movement of the tool is proportional to the sensed movement of the electromechanical tool.

4. The device of claim 1, wherein the control system is configured to send a control signal to the electromechanical arm that prevents movement of the arm and movement of the electromechanical tool.

5. The device of claim 1, further comprising a switch to disable the control signal.

6. The device of claim 1, wherein the motion sensor is disposed on the electromechanical tool.

7. The device of claim 1, wherein the electromechanical tool includes an end effector having opposed jaws configured to engage tissue therebetween.

8. A laparoscopic surgical device, comprising:
a manual tool assembly having an end effector;
a motion sensor coupled to the manual tool assembly and configured to sense movement of the manual tool assembly; and

an electromechanical arm coupled to the manual tool assembly and configured to receive a movement signal from the motion sensor, and configured to provide power motion assistance to the manual tool assembly.

9. The device of claim 8, wherein the motion sensor is coupled to the manual tool assembly.

10. The device of claim 8, wherein the power motion assistance of the electromechanical arm is proportional to the sensed movement of the manual tool assembly.

11. The device of claim 8, wherein the electromechanical arm is configured to selectively prevent movement of the manual tool assembly.

12. The device of claim 8, further comprising a switch to disable the power motion assistance.

13. The device of claim 8, wherein the end effector has opposed jaws configured to engage tissue therebetween.

* * * * *

专利名称(译)	具有动力辅助运动的混合机器人手术		
公开(公告)号	US20170086928A1	公开(公告)日	2017-03-30
申请号	US14/865870	申请日	2015-09-25
[标]申请(专利权)人(译)	爱惜康内镜外科, LLC		
申请(专利权)人(译)	爱惜康内镜外科, LLC		
当前申请(专利权)人(译)	爱惜康内镜外科, LLC		
[标]发明人	AULD MICHAEL D FELDER KEVIN D HALL STEVEN G		
发明人	AULD, MICHAEL D. FELDER, KEVIN D. HALL, STEVEN G.		
IPC分类号	A61B34/30		
CPC分类号	A61B34/30 A61B2017/00022 A61B2034/302 A61B34/32 A61B34/37 A61B34/74 A61B90/50 A61B2017/00477 A61B2090/064 A61B2090/066		
其他公开文献	US10485616		
外部链接	Espacenet USPTO		

摘要(译)

提供了用于进行机器人手术的方法和装置。通常，提供外科系统，其包括具有第一操作模式的机电工具，其中机电工具模拟控制器的移动，以及第二工作模式，其中工具反映控制器的运动。还提供了一种混合式手术装置，其包括适合于手柄组件的适配器，使得适配器电连接到手柄组件的电动机并且被配置为与电动机通信。还提供了一种机器人腹腔镜手术装置，其包括被配置为感测机电工具的运动运动传感器和辅助工具移动的机电臂。还提供了一种机器人手术装置，其包括与套管针相关联的机电驱动器，并且构造成旋转并平移通过通道设置的工具。

